

Operating Instructions

Multi-Hybrid Control Panel AW-RP555L

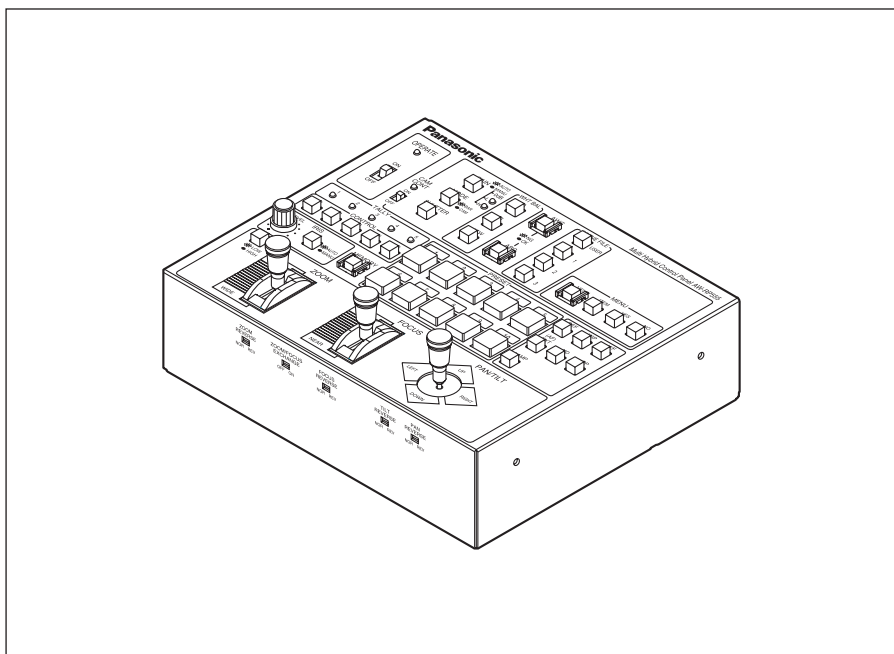

Panasonic®

Before attempting to connect, operate or adjust this product,
please read these instructions completely.

ENGLISH

DEUTSCH

FRANÇAIS

ITALIANO

ESPAÑOL

РУССКИЙ

中文

ENGLISH VERSION

■ DO NOT REMOVE PANEL COVERS BY UNSCREWING.

To reduce the risk of electric shock, do not remove the covers. No user serviceable parts inside.

Refer servicing to qualified service personnel.

WARNING:

- TO REDUCE THE RISK OF FIRE OR SHOCK HAZARD, DO NOT EXPOSE THIS EQUIPMENT TO RAIN OR MOISTURE.
- TO REDUCE THE RISK OF FIRE OR SHOCK HAZARD, KEEP THIS EQUIPMENT AWAY FROM ALL LIQUIDS. USE AND STORE ONLY IN LOCATIONS WHICH ARE NOT EXPOSED TO THE RISK OF DRIPPING OR SPLASHING LIQUIDS, AND DO NOT PLACE ANY LIQUID CONTAINERS ON TOP OF THE EQUIPMENT.

WARNING:

TO PREVENT INJURY, THIS APPARATUS MUST BE SECURELY ATTACHED TO THE FLOOR/WALL IN ACCORDANCE WITH THE INSTALLATION INSTRUCTIONS.

CAUTION:

TO REDUCE THE RISK OF FIRE OR SHOCK HAZARD AND ANNOYING INTERFERENCE, USE THE RECOMMENDED ACCESSORIES ONLY.

CAUTION:

In order to maintain adequate ventilation, do not install or place this unit in a bookcase, built-in cabinet or any other confined space. To prevent risk of electric shock or fire hazard due to overheating, ensure that curtains and any other materials do not obstruct the ventilation.

Note:

The rating plate (serial number plate) is on the bottom of the unit.

A warning that an apparatus with CLASS I construction shall be connected to a MAINS socket outlet with a protective earthing connection.

 indicates safety information.

Information on Disposal for Users of Waste Electrical & Electronic Equipment (private households)



This symbol on the products and/or accompanying documents means that used electrical and electronic products should not be mixed with general household waste.

For proper treatment, recovery and recycling, please take these products to designated collection points, where they will be accepted on a free of charge basis. Alternatively, in some countries you may be able to return your products to

your local retailer upon the purchase of an equivalent new product.

Disposing of this product correctly will help to save valuable resources and prevent any potential negative effects on human health and the environment which could otherwise arise from inappropriate waste handling.

Please contact your local authority for further details of your nearest designated collection point. Penalties may be applicable for incorrect disposal of this waste, in accordance with national legislation.

For business users in the European Union

If you wish to discard electrical and electronic equipment, please contact your dealer or supplier for further information.

Information on Disposal in other Countries outside the European Union

This symbol is only valid in the European Union.

If you wish to discard this product, please contact your local authorities or dealer and ask for the correct method of disposal.

Contents

Introduction	4
Accessories	4
Parts and their functions	5
Control panel	5
Front panel switches	14
Rear connector panel	16
Connections	19
Operation	23
Turning on the power	23
EXTERNAL CONTROL OUT setting	24
Adjusting the minimum start speed of the pan/tilt head	25
Adjusting the backlash compensation	26
Adjusting the minimum start speed of the lens zoom	27
Setting the travel range (limiters) of the pan/tilt head	28
Genlock adjustment	30
Total pedestal adjustment	30
White balance adjustment	31
Black balance adjustment	33
Preset memory settings	35
Setting and changing the camera menu items	37
Attaching the rack mounting adapters	38
Replacement of consumable parts	38
How to change the position of the connector panel	39
Appearance	40
Specifications	41

Introduction

- This unit is a multi hybrid control panel that controls the pan/tilt head system (pan/tilt head and convertible camera).
- Please use a 10BASE-T straight cable (UTP category 5) to connect to this unit.
- Up to 5 additional pan/tilt head systems may be connected to this unit. The connection between the pan/tilt head system and this unit may be extended up to 1,000 meters when using AW-PH360, AW-PH350 or AW-PH650 as the pan/tilt head. The distance may be extended to 800 meters when using other pan/tilt heads.
- Use cable compensation unit AW-RC400 when using a cable compensator for the video signal from the pan/tilt head system.

Pan/tilt heads supported

AW-PH350, AW-PH360 and AW-PH650

The control signals from the control panel can be connected to these units directly. AW-PH300, AW-PH300A, AW-PH500 and AW-PH600

The control signals from the control panel must be converted into RS-232C signals using a 422/232C converter before making the connection to the RS-232C connector on the pan/tilt head.

Camera control is also performed using the RS-232C interface.

When using AW-PH500 the camera cannot be controlled.

Recommended adapter

Use the dedicated AC adapter AW-PS505A (sold separately) for the power supply.

Caution

Please contact a specialist when discarding this unit in consideration of the environment.

Accessories

Rack mounting adapters (4U)	2
Join-up fixture	1
Mounting screws (M4×8 mm)	8

Parts and their functions

■ Control panel

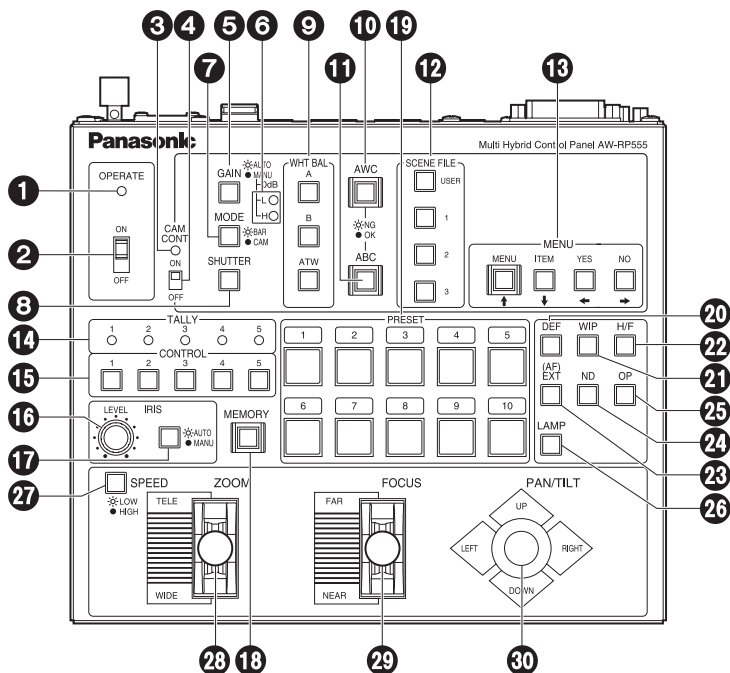

❶ OPERATE lamp

This lamp will come on when power is supplied to this unit and the OPERATE switch is on.

❷ OPERATE switch

This controls the power of all pan/tilt head systems (pan/tilt head and convertible camera) connected to this unit. Allow at least 5 seconds between ON/OFF operations. Setting the OPERATE switch to OFF will not turn the power to this unit off. To turn the power to this unit completely off, the power switch of AC adapter must be turned off.

❸ CAM CONT lamp

This lights when the CAM CONT switch is at ON and communication with the camera of the pan/tilt head system currently selected is taking place successfully. It goes off if trouble occurs in the communication.

When using a pan/tilt head other than the AW-PH350, AW-PH360 or AW-PH650, it remains off even when communication is taking place successfully.

Parts and their functions

4 CAM CONT switch

This switch is used to turn the control panel's camera control functions ON or OFF.

ON: Camera control is enabled (turned on).

OFF: Camera control is disabled (turned off).

The following functions can be turned on and off using the CAM CONT switch.

GAIN, MODE, SHUTTER, WHT BAL [A, B, ATW], AWC, ABC, SCENE FILE [USER, 1, 2, 3], MENU/↑, ITEM/↓, YES/←, NO/→

5 GAIN [AUTO/MANU] button

This is used to select the gain control mode of the camera in the pan/tilt head system currently selected. Each time it is pressed, the mode is switched by one step in the sequence of the auto mode and manual mode [0 dB, L (9 dB) and H (18 dB)].

If a setting other than 0 dB, 9 dB or 18 dB has been selected for the gain in the manual mode using the camera menu, it will be changed to the setting established by the operation of this button.

In the auto mode, the button's lamp lights; in the manual mode, it goes off.

6 MANU [L, H] lamp

These lamps turn on and off as follows when a MANU gain setting has been selected using the GAIN button.

0 dB	L lamp off	H lamp off
9 dB	L lamp on	H lamp off
18 dB	L lamp off	H lamp on

When a setting other than the above has been selected using the camera menu, both the L and H lamps turn on.

7 MODE [BAR/CAM] button

This is used to select the camera's video output signals in the pan/tilt head system currently selected.

Each time it is pressed, the camera's colour bar signals or video signals are selected in turn.

When the colour bar signals are selected, the button's lamp comes on; when the video signals are selected, it goes off.

Parts and their functions

⑧ SHUTTER button

This is used to select the shutter speed of the camera in the pan/tilt head system currently selected.

Each time the button is pressed, the set shutter speed is switched to shutter OFF or vice versa.

The shutter speed is actually switched as soon as the button is released.

At any setting except OFF, the button's lamp lights; at the OFF setting, it is off.

[How to register the shutter speed]

1. Press the SHUTTER button while holding down the MEMORY button.
2. The PRESET [1 to 5] buttons and PRESET [6 to 10] buttons start flashing alternately.
3. Press the PRESET button that corresponds to the shutter speed to be registered.

The table below lists the shutter speeds which can be set.

1/120	PRESET 1	1/4000	PRESET 6
1/250	PRESET 2	1/10000	PRESET 7
1/500	PRESET 3	SYNCHRO-SCAN	PRESET 8
1/1000	PRESET 4	ELC	PRESET 9
1/2000	PRESET 5	OFF	PRESET 10

※ When OFF is set, the shutter will not be operated even when the SHUTTER button is pressed.

Select the SYNCHRO-SCAN setting from the camera menu.

The change in the shutter speed is reflected when the shutter is next set to ON.

This setting is retained in the memory even after the control panel's power has been turned off.

[When temporarily changing the shutter speed without registering it]

Press the PRESET button corresponding to the shutter speed to be set while holding down the SHUTTER button.

Refer to the table above for the shutter speeds which can be set.

The shutter speed will be changed as soon as the PRESET button is pressed.

This setting will be cleared when either the shutter button is pressed or the camera's power is turned off.

Parts and their functions

9 WHITE BAL [A/B/ATW] buttons

These are used to select the camera's white balance adjustment in the pan/tilt head system currently selected.

- A:** When the A button is pressed, the white balance status entered in the camera's memory A is established, and the A button's lamp comes on.
If the AWC button is pressed after the A button was pressed, the white balance is automatically adjusted and entered in the camera's memory A.
- B:** When the B button is pressed, the white balance status entered in the camera's memory B is established, and the B button's lamp comes on.
If the AWC button is pressed after the B button was pressed, the white balance is automatically adjusted and entered in the camera's memory B.
- ATW:** When the ATW button is pressed, the white balance is set to the automatic adjustment mode, and the ATW button's lamp comes on.

10 AWC button

When the WHITE BAL [A] button or [B] button has been selected, press the AWC button to automatically adjust the white balance and enter the adjustment in the camera's memory A or memory B.

While the white balance is being adjusted, the AWC button's lamp flashes; when it has been adjusted properly, it goes off. It comes on when it was not possible to perform the adjustment.

- This function does not work if the MODE button has been set to BAR (the MODE button's lamp is lit) or if ATW has been selected.
- It may not be possible to adjust the white balance if there is no white object on the screen being shot.
- When using a pan/tilt head other than the AW-PH350, AW-PH360 or AW-PH650, the button's lamp also goes off when the white balance has not been adjusted properly.

Parts and their functions

11 ABC button

This is used to automatically adjust camera's black balance in the pan/tilt head system currently selected.

Set the IRIS [AUTO/MANU] button to AUTO (the IRIS button is now lit), and press the ABC button.

While the black balance is being adjusted, the ABC button's lamp flashes; when it has been adjusted properly, it goes off. It comes on when it was not possible to perform the adjustment.

- No operations are performed when the MODE button has been set to BAR (the MODE button's lamp is lit).
- When using a pan/tilt head other than the AW-PH350, AW-PH360 or AW-PH650, the button's lamp also goes off when the black balance has not been adjusted properly.

12 SCENE FILE [USER/1/2/3] buttons

These are used to select the SCENE FILE of the camera in the pan/tilt head system currently selected.

The lamp of the selected SCENE FILE button lights.

[In the case of the AW-E350, AW-E650, AW-E655, AW-E750 and AW-E860]

When the [USER] button's lamp lights, the user mode is selected.

When the [1] lamp lights, the halogen mode is selected.

When the [2] lamp lights, the fluorescent light mode is selected.

When the [3] lamp lights, the outdoor mode is selected.

13 MENU/↑, ITEM/↓, YES/←, NO/→ buttons

These are used to display the on-screen menus of the camera in the pan/tilt head system currently selected so that the settings can be performed on the menus.

When the MENU/↑ button is pressed for at least two seconds, the menu mode is established, the on-screen menus are displayed in the camera video output, and the MENU/↑ button lamp lights.

If the MENU/↑ button is pressed for at least two seconds in the menu mode, the menu mode is exited, the on-screen menus in the camera video output are cleared, and the MENU/↑ button lamp goes off.

For more details, refer to the "Setting and changing the camera menu items" (page 37).

14 TALLY lamps [1] to [5]

When tally signals are input to TALLY connectors [1] through [5], the lamps with the numbers corresponding to the connectors come on.

Parts and their functions

15 CONTROL buttons [1] to [5]

Pressing buttons 1 to 5 will select the connected pan/tilt head system.

When the AW-RC400 is connected, the button of the chosen number will illuminate and the video signal from the selected pan/tilt head system will be output to the AW-RC400's MONITOR OUT 1 to 2 terminals.

16 IRIS LEVEL control

This is used to adjust the iris of the lens in the pan/tilt head system currently selected.

When the IRIS button is set to MANU, the control can move the lens iris all the way from wide open to fully closed. When it is turned clockwise, the lens iris is opened; conversely, when it is turned counterclockwise, it is closed.

When the IRIS button is set to AUTO, the control can be used to adjust the [Video level] setting on the camera menu to adjust the focusing level of the automatic iris operation.

When it is turned clockwise, the lens iris is opened; conversely, when it is turned counterclockwise, it is closed.

- The lens iris is designed to be set only when the IRIS LEVEL control is moved.
- With this control panel, the auto iris adjust function of the camera menu is cancelled.

17 IRIS [AUTO/MANU] button

This is used to select how to adjust the lens iris of the pan/tilt head system currently selected.

Each time it is pressed, the AUTO or MANU setting is selected in turn.

AUTO: The lens iris is adjusted automatically, and the IRIS button's lamp comes on.

MANU: The lens iris is adjusted manually using the IRIS LEVEL control.

During this operation, the IRIS button lamp goes off.

18 MEMORY button

The lamp of this button goes off when communication has been established successfully with the pan/tilt head system currently selected; it flashes when communication has failed. If the lamp is flashing, check the power supply of the pan/tilt head system and the cable connections.

Press the MEMORY button to register settings in the preset memories of the pan/tilt head system or registering the limiter, shutter speed or other settings. For more details, refer to the description of each function concerned.

19 PRESET buttons [1] to [10]

These are used to register the preset memory data in the buttons.

Preset memory data: [1] to [10]

Parts and their functions

20 DEF button

This sets the defroster function ON or OFF when a pan/tilt head (AW-PH600/AW PH650) equipped with a defroster function is used in the pan/tilt head system currently selected.

Each time it is pressed, the function is turned ON or OFF in turn.

When the defroster is ON, the button's lamp comes on; when it is OFF, the lamp goes off.

21 WIP button

This sets the wiper function ON or OFF when a pan/tilt head (AW-PH600/AW-PH650) equipped with a wiper function is used in the pan/tilt head system currently selected.

Each time it is pressed, the function is turned ON or OFF in turn.

When the wiper is ON, the button's lamp comes on; alternatively, when it is OFF, it goes off.

22 H/F button

This sets the heater/fan function ON or OFF when a pan/tilt head (AW-PH600/AW PH650) equipped with a heater/fan function is used in the pan/tilt head system currently selected.

Each time it is pressed, the function is turned ON or OFF in turn.

When the heater/fan is ON, the button's lamp comes on; when it is OFF, the heater/fan goes off.

23 EXT (AF) button

If a lens with an extender function is used in the selected pan/tilt head system, the extender function is set from ON to OFF or vice versa each time the EXT (AF) button is pressed.

If a lens (AW-LZ16AF7G) with an AF function is used in the selected pan/tilt head system, the AF function of the lens is set from ON to OFF or vice versa each time the EXT (AF) button is pressed.

In either case, the button lamp is lit at the ON setting, and it is extinguished at the OFF setting.

※ This button can be used to turn the AF function ON or OFF only when the AW-PH350/AW-PH360/AW-PH650 pan/tilt head is connected.

When the pan/tilt head is not used and only the camera is connected, select ON or OFF using the menu item.

24 ND button

This sets the ND filter function ON or OFF when a lens equipped with an ND filter function is used in the pan/tilt head system currently selected.

Each time it is pressed, the function is turned ON or OFF in turn.

When the ND filter is ON, the button's lamp comes on; when it is OFF, the lamp goes off.

Parts and their functions

25 OP button

This controls the short- or open-circuiting of the OPTION SW CONTROL OUT connector of the AC adapter (AW-PS300A) which is connected to the pan/tilt head system currently selected.

Each time it is pressed, short-circuiting or open-circuiting is selected in turn.

When the connector is short-circuited, the button's lamp comes on; when it is open-circuited, the lamp goes off.

26 LAMP button

This controls the ON and OFF of the halogen lamp which is connected to the pan/tilt head system currently selected.

Each time it is pressed, the lamp is turned ON or OFF in turn.

When the halogen lamp is ON, the button's lamp comes on; when it is OFF, the lamp goes off.

It flashes when the halogen lamp has not been connected or when the lamp has been disconnected or some other problem has occurred.

27 SPEED button

This is used to select the control (pan, tilt, zoom, focus, iris) speed of the pan/tilt head system currently selected.

Each time it is pressed, the high-speed mode or low-speed mode is selected in turn.

The button's lamp comes on in the low-speed mode, and it remains off in the high-speed mode.

By pressing the SPEED button while holding down the MEMORY button, it is possible to set whether the high-speed mode or low-speed mode is to be selected when the power is turned on (or at OPERATE ON).

28 ZOOM lever

This is used to adjust the lens zoom in the pan/tilt head system currently selected.

Depending on the direction in which the ZOOM lever is tilted, TELE (telephoto) or WIDE (wide angle) is set, and depending on the angle at which it is tilted, the zoom speed is adjusted.

29 FOCUS lever

This is used to adjust the lens zoom in the pan/tilt head system currently selected. FAR or NEAR is set by the direction in which the FOCUS lever is tilted, and the focus speed is adjusted by the angle to which it is tilted.

Parts and their functions

30 PAN/TILT lever

This is used to adjust the direction of the pan/tilt head in the pan/tilt head system currently selected.

When the PAN/TILT lever is panned in the L/R direction, the pan/tilt head direction changes to the left or right; when it is tilted in the UP/DOWN direction, it changes in the up or down direction.

The speed is adjusted by the angle to which the lever is tilted.

Parts and their functions

■ Front panel switches

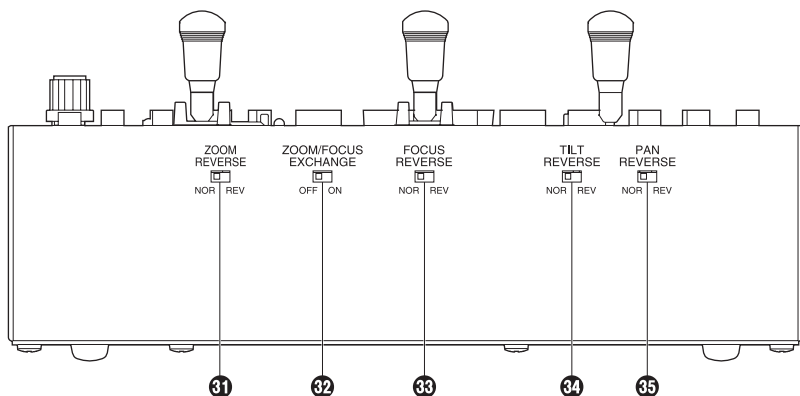

31 ZOOM REVERSE [NOR/REV] switch (Setting at shipment: NOR)

This is used to select the lens zoom operation which is to be performed by operating the ZOOM lever.

When it is set to NOR, the zoom moves toward the telephoto end when the ZOOM lever is tilted toward TELE or it moves toward the wide-angle end when the lever is tilted toward WIDE.

When it is set to REV, the zoom operates in the reverse directions.

32 ZOOM/FOCUS EXCHANGE [ON/OFF] switch (Setting at shipment: OFF)

This is used to select the ZOOM lever and FOCUS lever functions. When it is set to OFF, the ZOOM lever adjusts the zoom operation of the lens, and the FOCUS lever adjusts its focus operation.

When it is set to ON, the ZOOM lever adjusts the focus operation of the lens, and the FOCUS lever adjusts its zoom operation.

33 FOCUS REVERSE [NOR/REV] switch (Setting at shipment: NOR)

This is used to select the lens focus operation which is to be performed by operating the FOCUS lever.

When it is set to NOR, the point at which the lens is focused moves further away when the FOCUS lever is tilted toward FAR, and it comes closer when the lever is tilted toward NEAR.

When it is set to REV, focusing operates in the reverse directions.

Parts and their functions

34 TILT REVERSE [NOR/REV] switch (Setting at shipment: NOR)

This is used to select the operation of the pan/tilt head system in the vertical direction (tilting) which is to be performed by operating the PAN/TILT lever.

When it is set to NOR, the pan/tilt head system moves upward when the PAN/TILT lever is tilted toward UP, and it moves downward when the lever is tilted toward DOWN.

When it is set to REV, the tilting operates in the reverse directions.

Normally, set this switch to REV when using the AW-PH300 for the pan/tilt head system in a stand-alone installation.

When the switch is set to REV, the pan/tilt head system moves upward when the PAN/TILT lever is tilted toward UP, and it moves downward when the lever is tilted toward DOWN.

35 PAN REVERSE [NOR/REV] switch (Setting at shipment: NOR)

This is used to select the operation of the pan/tilt head system in the horizontal direction (panning) which is to be performed by operating the PAN/TILT lever.

When it is set to NOR, the pan/tilt head system moves toward the left when the PAN/TILT lever is tilted toward LEFT, and it moves toward the right when the lever is tilted toward RIGHT. When it is set to REV, the panning operates in the reverse directions.

Normally, set this switch to REV when using the AW-PH300 for the pan/tilt head system in a stand-alone installation.

When the switch is set to REV, the pan/tilt head system moves toward the left when the PAN/TILT lever is tilted toward LEFT and it moves toward the right when the lever is tilted toward RIGHT.

Parts and their functions

■Rear connector panel

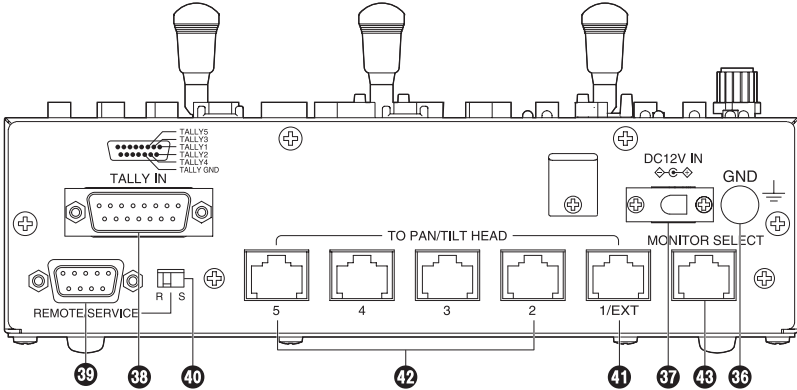

36 GND terminal

Use to ground the unit.

37 DC12V IN terminal

Connects the AW-PS505A AC adapter (sold separately).

38 TALLY IN connector

Connect this to the TALLY connector on the video switcher or other units.

When the TALLY connector is set to the GND level, the TALLY lamp (14) lights. Do not apply a voltage in excess of 5 V to this connector.

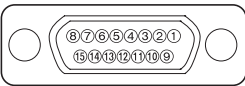

Pin layout as seen from the back of AW-RP555

Pin No.	Signal Name
1	TALLY1
9	TALLY2
2	TALLY3
10	TALLY4
3	TALLY5
11	TALLY GND
4	—
12	—
5	—
13	—
6	—
14	—
7	—
15	—
8	—

Parts and their functions

39 REMOTE/SERVICE connector

A personal computer or other external equipment is connected here when a pan/tilt head system is to be controlled by these equipments.

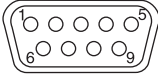

Pin No.	Signal Name
1	—
2	RXD IN
3	TXD OUT
4	DTR
5	GND
6	DSR
7	RTS
8	CTS
9	—

40 REMOTE/SERVICE switch (Setting at shipment: R)

Function selection switch for the REMOTE/SERVICE connector. Set the switch in the “R” position during use.

41 TO PAN/TILT HEAD 1/EXT terminal

- Functions as the pan/tilt head’s connection terminal 1 when the EXT CONTROL OUT is set to OFF on the EXTERNAL CONTROL OUT setting (see page 24).

Connect a 10BASE-T straight cable (equivalent to UTP category 5) to the pan/tilt head’s IP/RP terminal.

May be extended up to a maximum of 1,000 m.

Use the RS-232C/RS-422 converter and connect to pan/tilt head’s RS-232C control terminal when connecting to the AW-PH300, AW-PH300A, AW-PH500 or AW-PH600.

- Functions as the AW-DU600 dial up adapter’s connection terminal when the EXT CONTROL OUT is set to ON on the EXTERNAL CONTROL OUT setting (see page 24).

Connect a 10BASE-T straight cable (equivalent to UTP category 5) to the AW-DU600’s PAN/TILT CONTROL IN terminal. May be extended up to a maximum of 1,000 m.

For more details, refer to the operating instructions of the dial up adapter AW-DU600. Use the following terms instead:

- AW-RP605 ⇨ AW-RP555

- EXTERNAL CONTROL OUT terminal

⇨ TO PAN/TILT HEAD 1/EXT terminal

- There are no software version restrictions for this unit in systems with AW-DU600.

Parts and their functions

42 TO PAN/TILT HEAD 2 to 5 terminal

- Functions as the pan/tilt head's connection terminals 2 to 5 when EXT CONTROL OUT is set to OFF on the EXTERNAL CONTROL OUT setting (see page 24).

Connect a 10BASE-T straight cable (equivalent to UTP category 5) to the pan/tilt head's IP/RP terminal.

May be extended up to a maximum of 1,000 m.

Use the RS-232C/RS-422 converter and connect to pan/tilt head's RS-232C control terminal when connecting to the AW-PH300, AW-PH300A, AW-PH500 or AW-PH600.

- Cannot be used when the EXT CONTROL OUT is set to ON on the EXTERNAL CONTROL OUT setting (see page 24).

43 MONITOR SELECT terminal

Connect a 10BASE-T straight cable (equivalent to UTP category 5) to the AW-RC400 cable compensation unit's MONI SEL IN terminal. May be extended up to a maximum of 50 m.

The video signal from the pan/tilt head system connected to the input terminal, whose number is selected on this unit, will be sent from the AW-RC400's MONITOR 1, 2 terminals.

Connections

Turn off the power of all components before proceeding with the connections.

- Use the AW-PS505A (sold separately) AC adapter for this unit and the AW-PS300A (sold separately) for the pan/tilt head.
- Use a DC power cable (which has a nominal cross-sectional area of at least 1.25 mm² and which complies with the Electrical Appliance and Material Control Law) to connect the AW-PH360 pan/tilt head and AW-PS300A AC adapter.
The maximum extension distance between the AC adapter for the pan/tilt head and the pan/tilt head itself is 30 meters.
- Connect the AW-PH360 pan/tilt head and convertible camera using the camera cable supplied with AW-PH360.
- Connect the iris control cable of the motorized zoom lens to the camera and the remote (zoom/focus control) cable to the pan/tilt head.
- When using the AW-PH360 as the pan/tilt head, set the controller selector switch on the AW-PH360 to “For AW-RP605A”.

For further details on how to connect each component, refer to the operating instructions of the component concerned.

Connections

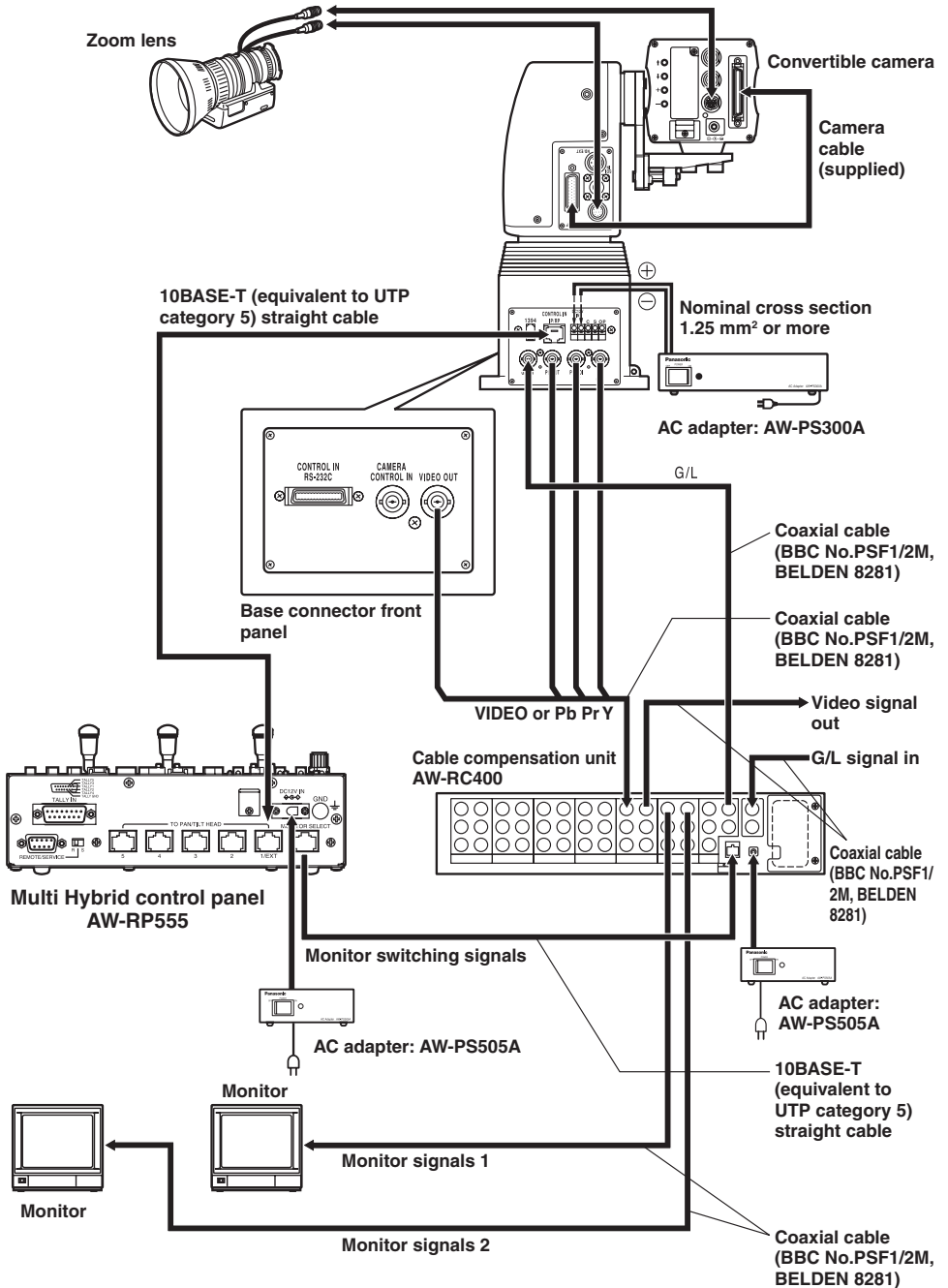

Connections

When using the AW-PH300, AW-PH300A, AW-PH500 or the AW-PH600 pan/tilt head

The control signal from this unit must be converted from RS-422 to RS-232C.

Consult with your dealer concerning the RS-232C/RS-422 converter and connecting cable.

Shown below is an example of the connections performed by the RS-232C/RS-422 converter.

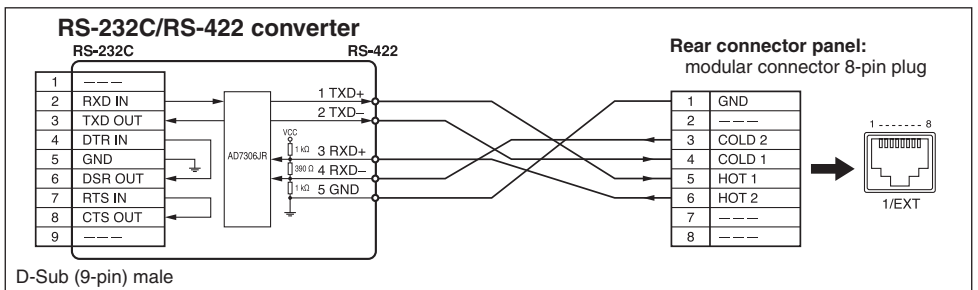
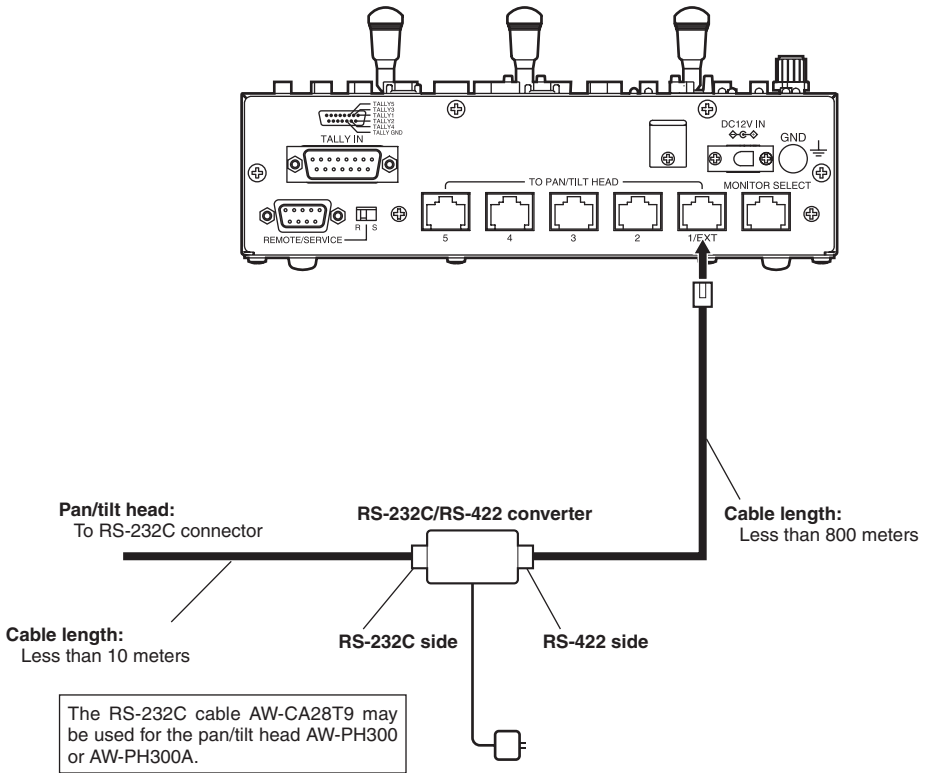

Connections

Example of system configuration

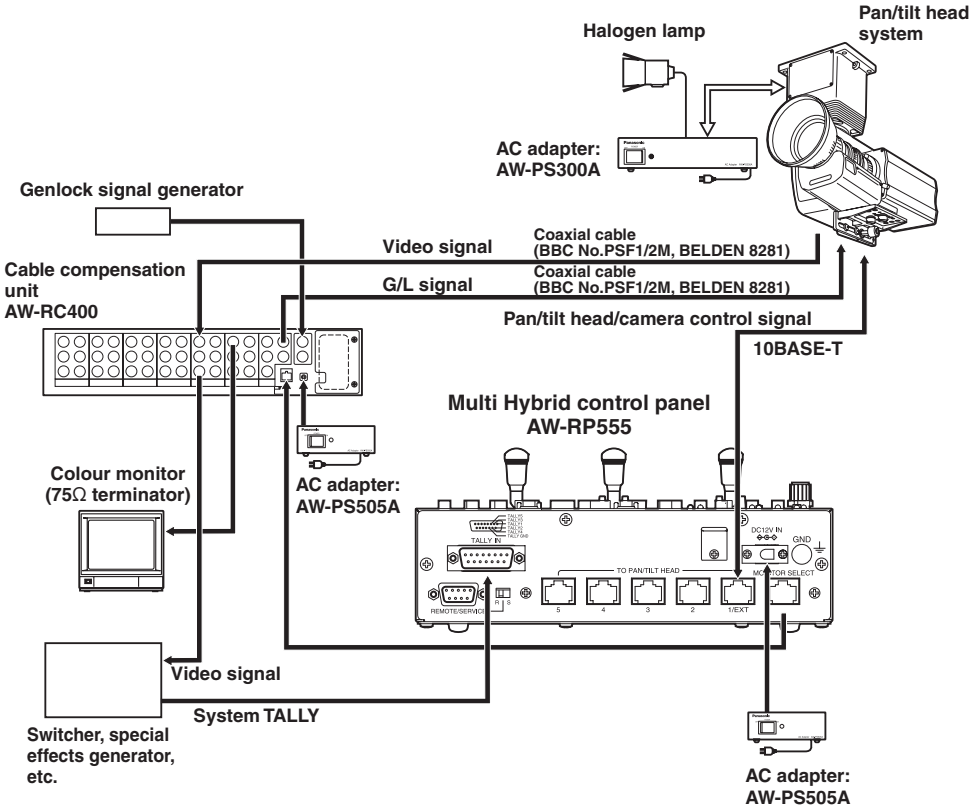

Operation

■Turning on the power

1. Set all the power switches of the connected components and the power switch of the AC adapter to ON.
2. Set this unit's OPERATE switch to ON.
Power will be supplied to the pan/tilt head system connected to this unit, and the camera's initial settings will be performed in sequence.
 - It takes about 5 seconds to perform the camera's initial settings for each camera. The pan/tilt head system cannot be controlled until these settings are completed.
 - Be sure to set power switches on all connected equipment and AC adapters to ON before setting the control panel's OPERATE switch to ON.

When the pan/tilt head system is connected (or changed) and its power is turned on for the first time, the connected cameras will be initialized. Upon completion of the initialization, adjust or set the following items. After the items are adjusted or set, proceed to the section entitled "Setting the travel range (limiters) of the pan/tilt head".

Once the adjustments are made, there is no need for any re-adjustments unless changes are made to the pan/tilt head, camera or lens. (The items to the re-set or re-adjusted differ depending on the unit which is changed.)

■ EXTERNAL CONTROL OUT setting

Set this to ON when connecting the AW-DU600 dial up adapter to the control panel's TO PAN/TILT HEAD 1/EXT connector. Normally, set it to OFF.

1. Press the LAMP button while holding down the MEMORY button.
2. The LAMP button's lamp starts flashing, and the standby status is established.
3. Press the LAMP button to establish the setting mode. The lamps of both the MEMORY button and LAMP button start flashing, and the status currently set is indicated as follows:
 - When the PRESET 5 button lamp is lit:
EXTERNAL CONTROL OUT ON
 - When the PRESET 10 button lamp is lit:
EXTERNAL CONTROL OUT OFF
4. Press the PRESET 5 button to set to EXTERNAL CONTROL OUT ON.
Press the PRESET 10 button to set to EXTERNAL CONTROL OUT OFF.
The lamps of both the MEMORY button and LAMP button stop flashing, and the setting mode is exited.

Operation

■ Adjusting the minimum start speed of the pan/tilt head

When the pan/tilt head is to be operated manually using the joystick, its minimum start speed is automatically adjusted to ensure that the pan/tilt head will start moving smoothly in response to the angle to which the PAN/TILT lever is tilted. (This will reduce the amount of play in the PAN/TILT lever.)

1. Use the CONTROL button to select the pan/tilt head whose minimum start speed is to be adjusted.
2. Press the MODE button while holding down the MEMORY button.
3. The MODE button lamp starts flashing, and the standby status is established.
4. Press the MODE button to start the adjustment.
5. While the minimum start speed is being adjusted, the lamps of both the MEMORY button and MODE button flash.
6. The adjustment is completed when the lamps of both the MEMORY button and MODE button go off.
7. Repeat steps 2 to 6 for the other pan/tilt heads.

If the lamps of both the MEMORY button and MODE button light up and the adjustment process ends, check whether the camera mounted on the pan/tilt head is balanced properly and whether the pan/tilt head cable or other parts are making contact with any objects in the vicinity before proceeding again from step 2.

When the joystick is operated while the minimum start speed is being adjusted, the adjustment will be forcibly terminated and only that portion of the setting performed up until that point will be stored in the memory.

■ Adjusting the backlash compensation

Play in the gears may give rise to backlash when the pan/tilt head is moved. This adjustment serves to provide compensation for reducing the amount of this backlash. (Backlash: For instance, after the pan/tilt head has moved from right to left and then come to a standstill, there is a delay in the start of the movement when it moves in the opposite direction. This happens because of play in the gears. The same phenomenon also occurs when the head moves from left to right, up to down or down to up.)

1. Use the CONTROL button to select the pan/tilt head whose backlash compensation is to be adjusted.
2. Press the MENU button while holding down the MEMORY button.
3. The MENU button lamp starts flashing, and the standby status is established.
4. Press the MENU button to establish the setting mode. The lamps of both the MEMORY button and MENU button start flashing. If the joystick is operated at this point, the adjustment will be forcibly terminated.
5. Press the PRESET 1 to 8 buttons to set the compensation amounts. This amount is lowest for the PRESET 1 button and highest for the PRESET 8 button. When the PRESET 10 button is pressed, the compensation is set to OFF. When the PRESET 1 to 8 and 10 buttons are pressed, the lamps of both the MEMORY button and MENU button stop flashing, and the setting mode is exited.
The same backlash compensation values are applied to both panning and tilting.
✳ Use the OFF setting if backlash is not a concern. When making an adjustment, be absolutely sure to move the pan/tilt head, and perform actual operations to check whether the compensation amount is appropriate before deciding on the proper amount. If this amount is excessive, the pan/tilt head will start returning in the opposite direction as soon as it has been made to come to a standstill.
6. If the compensation amount is inadequate, repeat steps 2 to 5, and find the optimum setting.
7. Repeat steps 2 to 6 for the other pan/tilt heads.

Operation

■ Adjusting the minimum start speed of the lens zoom

Perform this adjustment to ensure that the lens zoom will function smoothly in response to the angle to which the ZOOM lever is tilted when it is used to zoom the lens.

1. Use the CONTROL button to select the pan/tilt head whose lens zoom minimum start speed is to be adjusted.
2. Press the IRIS button while holding down the MEMORY button.
3. The IRIS button lamp starts flashing, and the standby status is established.
4. Press the IRIS button to establish the setting mode. The lamps of both the MEMORY button and IRIS button start flashing. If the joystick is operated at this point, the adjustment will be forcibly terminated.
5. Press the PRESET 1 to 8 buttons to set the compensation amounts. This amount is lowest for the PRESET 1 button and highest for the PRESET 8 button. When the PRESET 10 button is pressed, the compensation is set to OFF. When the PRESET 1 to 8 and 10 buttons are pressed, the lamp of the IRIS button stops flashing, and the setting mode is exited.
6. Move the ZOOM lever slowly and, while monitoring the image on the monitor, check whether the lens zoom starts moving smoothly. If the lens zoom fails to start moving smoothly, repeat steps 2 to 5 and find the optimum value.
7. Repeat steps 2 to 6 for the other pan/tilt heads.

■ Setting the travel range (limiters) of the pan/tilt head

Depending on where it has been installed, there may be obstacles within the travel range of the pan/tilt head system with which the system may come into contact.

The pan/tilt head system may malfunction or an accident may occur if the system comes into contact with such an obstacle.

Prior to use, be absolutely sure to set the travel range (limiters: upper, lower, left-most and right-most limits of rotation) of the pan/tilt head system.

Before installing a pan/tilt head as a stand-alone type, set the installation direction switch inside the pan/tilt head to stand-alone installation. ("Suspended installation" is the factory setting.)

If this switch is not set properly, the operating directions of the pan/tilt head will be reversed, and the limits of the pan/tilt head's travel range (limiters) will not be stored in the memory properly. For details on how to set the switch, refer to the operating instructions of the pan/tilt head.

1. Select the pan/tilt head system using the CONTROL button.
2. Set the upper limit position in the travel range.
 - ① Operate the PAN/TILT lever on the control panel to rotate the camera to the position which is to serve as the upper limit position.
 - ② Press the PRESET 2 and 3 buttons while holding down the MEMORY button on the control panel.
 - ③ When the button 5 lamp lights, the setting is completed.
 - To cancel the setting, press the PRESET 2 and 3 buttons again while holding down the MEMORY button. When the setting is cancelled, the button 10 lamp lights.
3. Set the lower limit position in the travel range.
 - ① Operate the PAN/TILT lever to rotate the camera to the position which is to serve as the lower limit position.
 - ② Press the PRESET 7 and 8 buttons while holding down the MEMORY button.
 - ③ When the button 5 lamp lights, the setting is completed.
 - To cancel the setting, press the PRESET 7 and 8 buttons again while holding down the MEMORY button. When the setting is cancelled, the button 10 lamp lights.
4. Set the left end position in the travel range.
 - ① Operate the PAN/TILT lever to rotate the camera to the position which is to serve as the left end position.
 - ② Press the PRESET 1 and 6 buttons while holding down the MEMORY button.
 - ③ When the button 5 lamp lights, the setting is completed.
 - To cancel the setting, press the PRESET 1 and 6 buttons again while holding down the MEMORY button. When the setting is cancelled, the button 10 lamp lights.

Operation

5. Set the right end position in the travel range.
 - ① Operate the PAN/TILT lever to rotate the camera to the position which is to serve as the right end position.
 - ② Press the PRESET 4 and 9 buttons while holding down the MEMORY button.
 - ③ When the button 5 lamp lights, the setting is completed.
 - To cancel the setting, press the PRESET 4 and 9 buttons again while holding down the MEMORY button. When the setting is cancelled, the button 10 lamp lights.

6. Use the CONTROL button to switch the pan/tilt head system, and set the travel ranges (limiters) for each system concerned.

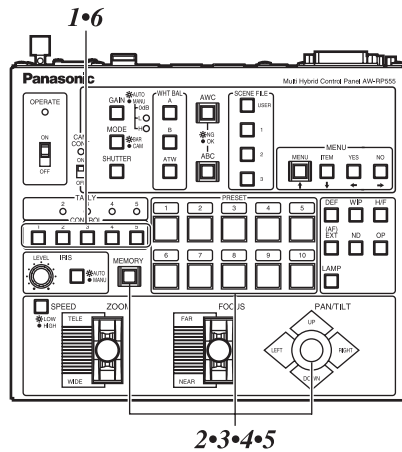

■ Genlock adjustment

If a camera is to be synchronized with an external signal for use, genlock adjustment must be performed for the camera and other equipments.

Either the black burst or VBS (video, burst and sync) signal is used for the external sync signal.

There is no need to perform the genlock adjustment if the camera is not going to be synchronized with an external signal.

For the genlock adjustments, open the camera menu and perform the settings. Refer to the instructions accompanying the camera and cable compensator.

■ Total pedestal adjustment

When more than one camera is to be used, the black level (pedestal level) of the pictures shot by each of the cameras must be brought into alignment.

Set the black level (pedestal level) using the camera menu. For details, refer to the instructions accompanying the camera.

Operation

■ White balance adjustment

The white balance must be adjusted when the equipment is used for the first time, when it has not been used for a prolonged time or when the lighting conditions or brightness has changed.

The white balance conditions can be entered in advance into channels A and B.

If the equipment is to be used under conditions which are identical to the entered settings, it means that no further adjustment need be undertaken since the white balance will be set simply by pressing the WHITE BAL A button or B button once the white balance has been adjusted.

When the white balance is adjusted again, the previously entered settings will be deleted and replaced by the new conditions.

Automatic adjustment of white balance

1. Select the pan/tilt head system using the CONTROL button.
2. Shoot a white object (such as a white wall or handkerchief) to fill the whole screen using the pan/tilt head system currently selected.

Do not allow shiny, reflective or very bright objects to appear on the screen.

3. Press the WHITE BAL A button, and press the AWC button. The AWC button's lamp flashes, and the white balance is automatically adjusted. Once the adjustment has been performed correctly, the lamp goes off, and the conditions set are entered in channel A. The AWC button's lamp will remain lit if it was not possible for the adjustment to be performed. In this case, change the brightness, iris, object, light source, etc., and perform the adjustment again.

The AWC button's lamp goes off even if the white balance adjustment was not performed correctly in cases where a pan/tilt head system other than the AW-PH350, AW-PH360 or AW-PH650 is being used.

4. Similarly, enter the conditions set for channel B using the WHITE BAL B button.
5. Select the next pan/tilt head system using the CONTROL button, and continue adjusting the white balance in each system concerned.

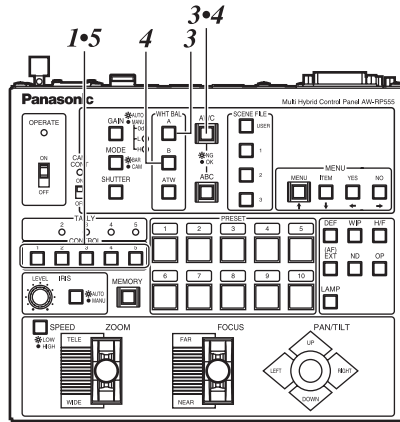

Automatic tracing white balance (ATW)

When the WHITE BAL ATW button is pressed during shooting, the ATW button's lamp comes on, compensation is provided so that the white balance will be automatically adjusted even if the light source or colour temperature has changed in order to minimize an unnatural appearance in the resulting images.

If nothing white is shown on the screen, it may not be possible for the white balance to be compensated properly. Similarly, with some light sources or colour temperatures, it may not be possible for the white balance to be compensated properly.

Operation

■ Black balance adjustment

The black balance must be adjusted when the equipment is used for the first time, when it has not been used for a prolonged time, when the ambient temperature has changed significantly or when one season gives way to another.

If the equipment is to be used under conditions which are identical to the entered settings, no further adjustments are necessary.

When the black balance is adjusted again, the previously entered settings will be deleted and replaced by the new conditions.

Automatic adjustment of black balance

1. Select the pan/tilt head system using the CONTROL button.
2. Press the IRIS button to set the currently selected pan/tilt head system to the AUTO mode (the IRIS button's lamp now comes on).

3. Press the ABC button.

The ABC button's lamp flashes, the lens iris is automatically stopped down, and the black balance is automatically adjusted. Once the adjustment has been performed correctly, the lamp goes off, and the conditions set are entered in the memory.

The ABC button's lamp will remain lit if it was not possible for the adjustment to be performed. In this case, repeat the adjustment procedure.

- It may not be possible to adjust the black balance if the total pedestal is too low. In this case, adjust the total pedestal again, and then repeat the black balance adjustment.
- The ABC button's lamp goes off even if the black balance adjustment was not performed correctly in cases where a pan/tilt head system other than the AW-PH350, AW-PH360 or AW-PH650 is being used.

4. Select the next pan/tilt head system using the CONTROL button, and continue adjusting the black balance in each system concerned.

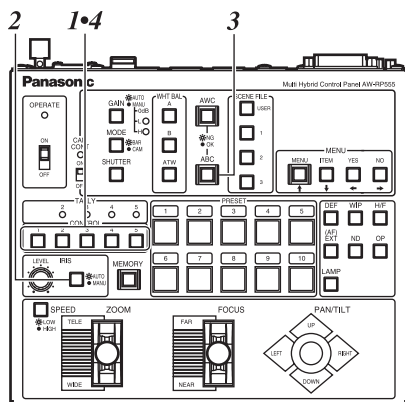

Operation

■ Preset memory settings

The multi hybrid control panel is equipped with a preset memory function for entering the positions and settings with which the pan/tilt head system is to shoot. Preset memory data is entered into PRESET buttons 1 through 10.

Pan/tilt head system's settings

Pan/tilt head:

Pan/tilt position

Camera:

Zoom, focus, iris (MANU mode only), white balance

Entering preset memory data

1. Select the pan/tilt head system using the CONTROL button.
2. Use the following buttons to establish the modes.
 - Press the IRIS button to establish the MANU mode (the IRIS button's lamp now goes off).
If the AUTO mode is established, the lens iris position will not be entered.
3. Operate the ZOOM lever and PAN/TILT lever, and on the monitor check the pictures which are to be shot.
4. Select the white balance from among the A, B and ATW buttons, and adjust the lens iris using the IRIS LEVEL control.
5. Set the unit to a state in which the MEMORY button is held down.
When the MEMORY button is pressed, those buttons among the PRESET buttons 1 through 10 in which data can be entered start flashing in sequence.
6. While the MEMORY button is held down, press the button in which the preset memory data is to be entered.
7. If necessary, enter other shooting positions and settings into other buttons among PRESET buttons 1 through 10 as preset memory data.
8. Select the next pan/tilt head system using the CONTROL button, and continue setting the preset memory data for each system concerned.

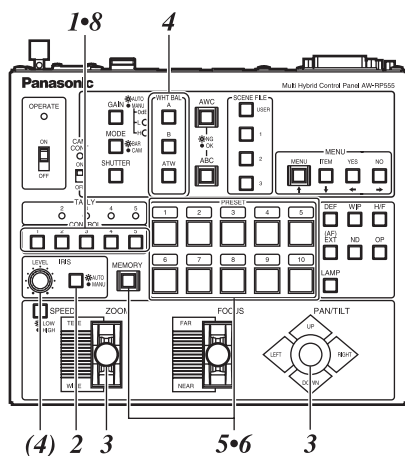

Deleting preset memory data

1. Select the pan/tilt head system using the CONTROL button.
2. Press the OP button while holding down the MEMORY button.
3. The OP button lamp starts flashing, and the standby mode is established.
4. Press the OP button to establish the setting mode.
The lamps of the PRESET 1 to 10 buttons start flashing in sequence. If the joystick is operated at this point, the deletion operation will be forcibly terminated.
5. Press the PRESET buttons whose memory data is to be deleted.
6. If necessary, delete other preset memory data as well.

Setting and changing the camera menu items

■ Setting procedure

1. Keep pressing the MENU/↑ button for two seconds.
The menu mode is established, and the on-screen menus of the camera in the pan/tilt head system currently selected are displayed. At this point, the MENU/↑ button lamp remains lit.
If the MENU/↑ button is held down for at least two seconds while the MENU/↑ button lamp is lit, the menu mode is exited, and the on-screen menus can be closed.
2. When the unit is in MENU mode, the MENU/↑ button, ITEM/↓ button, YES/← button and NO/→ button correspond to the 4 switches on the back of the convertible camera as shown below. The MENU is operated using these buttons.

MENU/↑MENU

ITEM/↓ITEM/AWC

YES/←YES/ABC

NO/→NO/BAR

For details about MENU operations, refer to the operating instructions of the camera.

3. Upon completion of the settings, keep pressing the MENU/↑ button for two seconds to exit the menu mode. The on-screen menus are now cleared, and the MENU/↑ button lamp goes off.

Do not close the on-screen menus by performing menu operations.

If the menus have been closed by mistake, keep pressing the MENU/↑ button for at least two seconds to turn off the MENU/↑ button lamp.

Attaching the rack mounting adapters

- To install this unit in a rack, use the rack mounting adapters, join-up fixture and mounting screws (M4×8 mm) supplied.
- Use only the mounting screws provided — do not use any other screws.

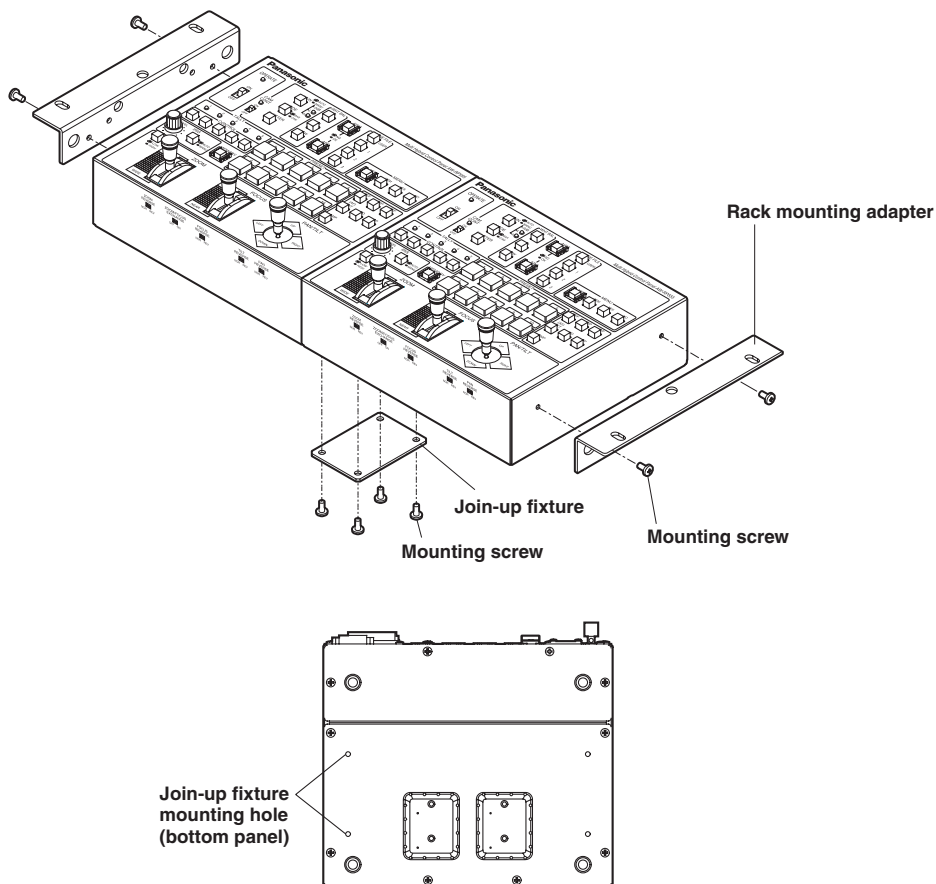

Replacement of consumable parts

• Joystick replacement

The joystick is a consumable part.

Replace the joystick if operation is impeded.

Refer replacement of the joystick to qualified service personnel.

How to change the position of the connector panel

The position of the connector panel can be changed from the rear panel to the bottom panel.

*** Before changing the position, turn off the power.**

① Remove the four bottom panel screws, and remove the blank panel.

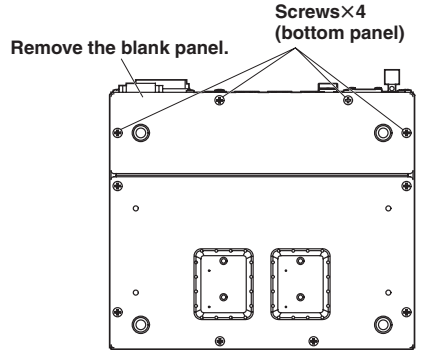

② Remove the four rear panel screws, and remove the connector panel.

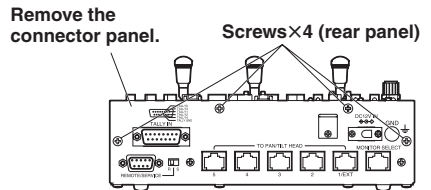

③ Secure the blank panel to the rear panel using the screws.

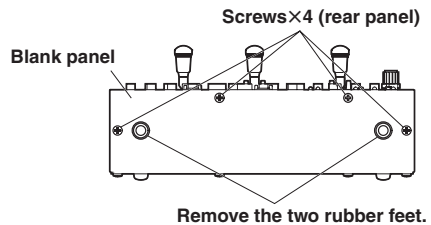

④ Remove the two rubber feet from the blank panel.

⑤ Secure the connector panel to the bottom panel using the screws.

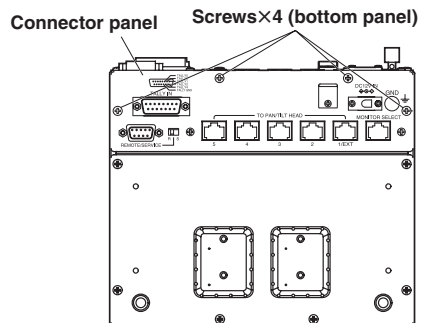

Appearance

Unit: mm

ENGLISH

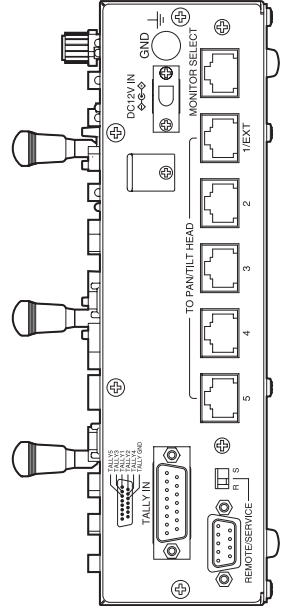
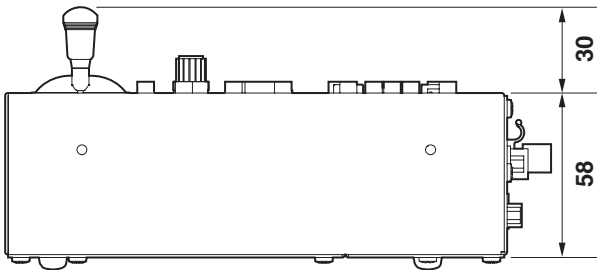
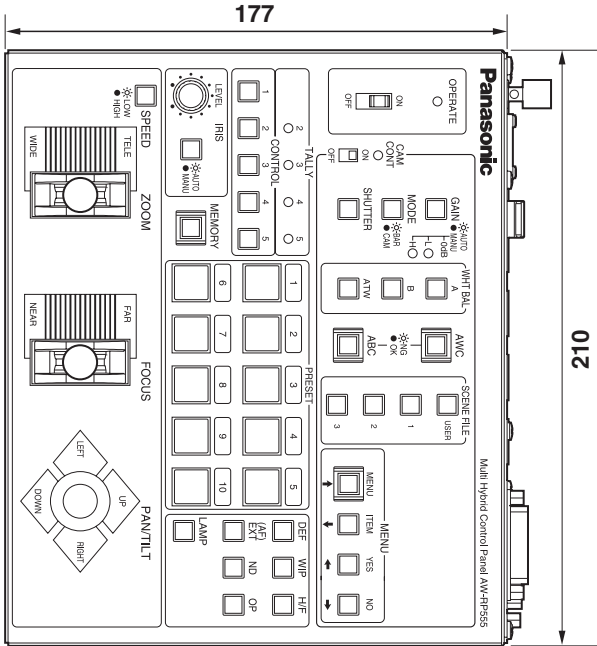

Specifications

Power supply: DC 10.8 V to DC 16 V
Power consumption: 9.0 W

 indicates safety information.

■ General

Ambient operating temperature

-10°C to +50°C

Storage temperature

-20°C to +60°C

Ambient operating humidity

30% to 90% (no condensation)

Weight

1.4 kg

Dimensions (W×H×D)

210×177×58 mm (excluding protrusions)

Finish

AV ivory paint (colour resembling Munsell 7.9Y 6.8/0.8)

Pan/tilt heads supported

AW-PH300, AW-PH300A, AW-PH350, AW-PH360,
AW-PH500, AW-PH600, AW-PH650

Cameras supported

AW-E300, AW-E300A, AW-E600, AW-E800, AW-E800A, AW-E350, AW-E650, AW-E655,
AW-E750, AW-E860

■ Input connectors

DC 12V IN socket

DC jack

GND

Please ground before using the unit.

Specifications

■ Output connectors

MONITOR SELECT connector

RJ45

Connecting cable:

10BASE-T straight cables (UTP category 5), max. 50 meters

■ Input/Output connectors

TALLY

D-SUB, 15-pin

REMOTE/SERVICE

RS-232C

TO PAN/TILT HEAD [1/EXT, 2 to 5] connectors

RJ45 × 5, control signal output for pan/tilt heads

Connecting cable:

10BASE-T straight cables (UTP category 5), max. 1,000 meters

■ Other

REMOTE/SERVICE switch

Maintenance switch. Set in the “R” position during use.

ZOOM REVERSE switch

Used to reverse the polarity of the ZOOM lever.

ZOOM/FOCUS EXCHANGE switch

Used to replace the ZOOM lever with the FOCUS lever or vice versa.

FOCUS REVERSE switch

Used to reverse the polarity of the FOCUS lever.

TILT REVERSE switch

Used to reverse the polarity of the TILT lever.

PAN REVERSE switch

Used to reverse the polarity of the PAN lever.

Weight and dimensions shown are approximate.
Specifications are subject to change without notice.

Matsushita Electric Industrial Co., Ltd.

Web Site: <http://www.panasonic.co.jp/global/>

Printed in Japan
Gedruckt in Japan
Imprimé au Japon
Stampato in Giappone
Impreso en Japón
Напечатано в Япони
在日本印制

VQTB0114

F0306S1046 