

Cineroid *EVF*

Electronic View Finder

User Manual

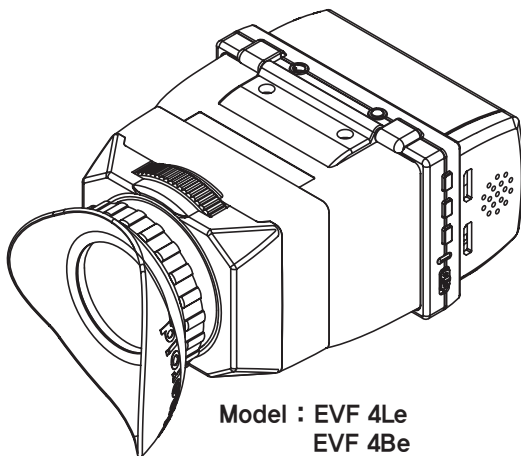

Model : EVF 4Le
EVF 4Be

Cineroid

| Thank you for purchasing the Cineroid EVF.

The Cineroid EVF (hereafter referred to as "EVF") is a view finder that can be mounted on any video camera with a HDMI output signal. Please thoroughly read the user manual for best operation and understanding of all of the functions of the EVF.

| Test Before Operating

It is recommended to test the EVF before operating. Check if the EVF can be turned on once powered, and check if the information/menu is being properly displayed on the LCD.

| Copyrights and Prohibitions

The use of images of people, property, and places can without permission can be prohibited by law. Please refer to your region's laws regarding copyrights.

- Canon and EOS are registered trademarks of Canon.
- Nikon is a registered trademark of Nikon.
- Sony is a registered trademark of Sony.

| Safety Precautions

①

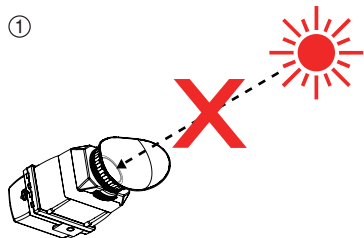

②

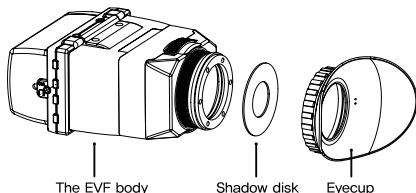

1. Do not face the eyecup directly into the sun as it may damage the LCD.
2. The shadow disk is installed on EVF at factory.
This shadow disk can be removed by disassembling eyecup from loupe.

| Safety Precautions

Please observe the following safety precautions as they are meant for the safe and proper use of the product to reduce the risk of accidents. Upon reading the user manual, keep it in a safe and available place.

- Ⓢ Do not use any batteries, power cord, or accessories that are not specified in this document.
- Ⓢ When using a power cord, be sure to plug it in completely. Do not handle power plugs when your hands are wet. When unplugging the power cord, grasp the plug body or adapter instead of the cord.
- Ⓢ Power cords that are scratched, heavily bent or twisted can potentially be hazardous and a source of electric shock and/or fire.
- Ⓢ Do not insert foreign objects into the product's electric or cable components.
- Ⓢ Do not place the power cord near sources of heat as this may melt or cause damage to the cord potentially causing fire or electric shock.
- Ⓢ Do not disassemble or modify the product. This may damage the product and cause danger due to a malfunction.
- Ⓢ Please keep the product out of reach of young children. Injuries may occur due to damage to the product.
- Ⓢ When using the product in an airplane or hospital setting, it is recommended to acquire authorization first as signals or electro-magnetic waves from the product may cause other equipment to malfunction.
- Ⓢ Do not store the product in a dusty or humid environment as damage may occur.
- Ⓢ When the product is mounted on a camera, do not lift or move the camera by grabbing the product. This may cause damage to the product or the camera mount.
- Ⓢ Do not clean the product with paint thinner, benzene, or other volatile solvents. This may cause damage to the product and become a fire hazard.
- Ⓢ This product is not waterproof. If the product is dropped in water, contact the service center immediately.

I Table of Contents

Safety Precautions	03
Table of Contents	04
Configuration	06
Parts	07

Before Using the EVF

Detachable Optical Viewfinder	08
Installing the Battery	08
Connecting External Power	09
Powering On/Off	09
Adjusting the Diopter	10
Connecting a HDMI Cable	10
Connecting a Composite Cable	11
Connection a Monitor	11

Basic Features

Operating the Menu	12
Input Selection	13
Adjusting Color	13
Adjusting the Screen	14
Adjusting the Volume	14

Shooting Features

Peaking	15
Anamorphic	16
Crop Guide	16
Over Scaling	17
Center Maker	17
Clip guide	18
False color	18
Firmware Upgrade	19
Screen Flip	19
Pixel to Pixel	20
Underscan	20
Monochrome	21
Custom Button Functions	21

Setting User Controls

OSD Setting	22
Parameter save and restore	22
Factory reset	22
Product Specifications	23
Optional Products	24
MEMO	26

| Components

Please ensure all parts are present after opening the box.

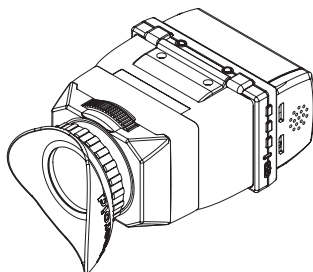

A. LCD VF + Optical Loupe

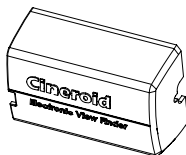

B. Battery Cover

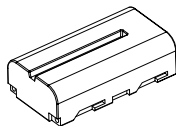

C. Battery

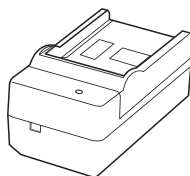

D. Battery Charger

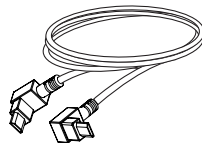

E. Mini HDMI Cable

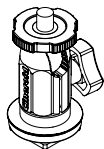

F. Mini Shoe Mount Adapter

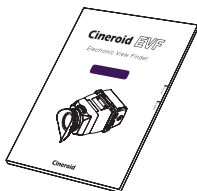

G. User Manual



H. Cineroid EVF Carrying Case

I Parts

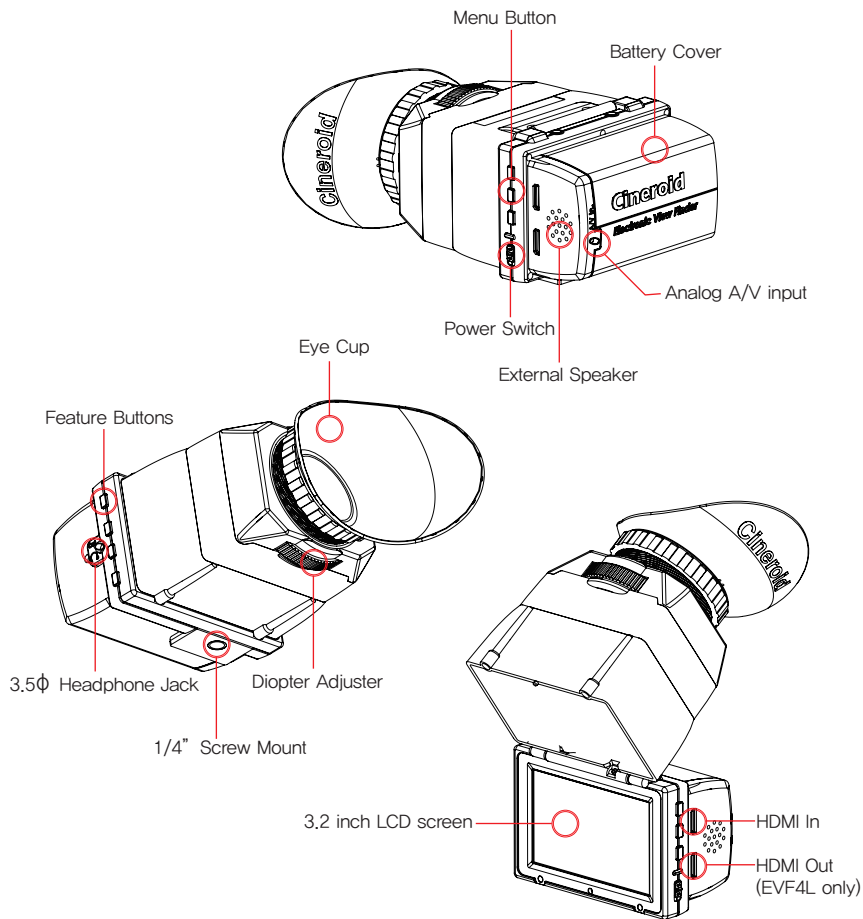

I Before Using the EVF

Detachable Optical Loupe

1. The optical loupe attached to the EVF body can be flipped open 180 degrees or detached completely.
2. To open the optical loupe, firmly grasp the loupe and flip upwards. When it is fully open, the loupe will stay fixed on top of the body.
3. To completely detach the loupe from the body, simply slide the small latch to the left and lift up the loupe. To replace the loupe, slide the small latch to the left and place the loupe back into place.

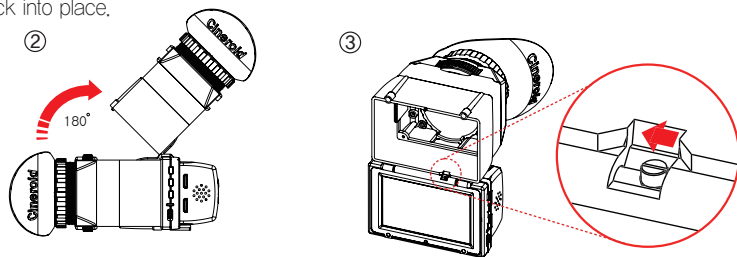

Installing the Battery

1. The Cineroid EVF can be used with small, medium or large sized batteries. The battery cover can only be used with the small sized batteries.
2. Remove the battery cover.
3. Push the battery in towards the direction of the arrow making sure the battery is properly aligned in place.
4. The battery or the connectors may be damaged if not aligned properly.
5. The Canon LP-E6 battery can only be used in conjunction with the PA01 adapter.

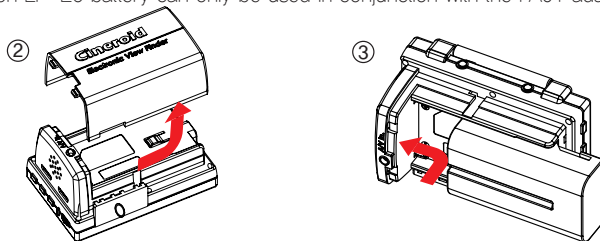

I Before Using the EVF

Connecting External Power

1. External power is supplied through the use of the PA01 adapter.
2. Proper voltage for external power is 6–17V.
3. To install the PA01 adapter, first remove the battery from the body.
4. Connect the external power cable to the PA01 adapter, as illustrated in the picture below.
5. Install the PA01 adapter to the body using the same method as installing the battery.
6. You can use the Canon LP-E6 battery with the PA01 adapter installed.

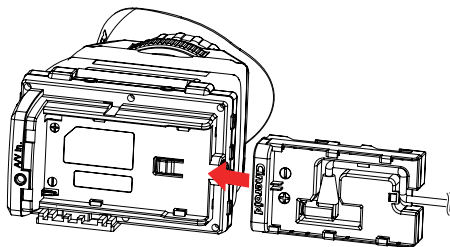

Powering On/Off

1. Install the battery or connect external power.
2. Turn the power switch to the ON position.
3. A red light will indicate that the power and LCD is turned ON.
4. If you have an external input, you will see the image displayed from that signal. If there is no external input, you will see the default screen.
5. Turn the power switch to the OFF position to turn off.

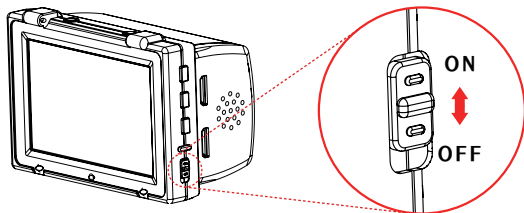

I Before Using the EVF

Adjusting the Diopter

1. When viewing through the optical loupe, the user can adjust the diopter accordingly.
Turn on the EVF and verify the LCD image output.
2. Rotating the dial to the right will bring the eye cup towards you and rotating it to the left will move the eye cup away from you.
3. Rotate the dial in either direction until the image becomes clear.

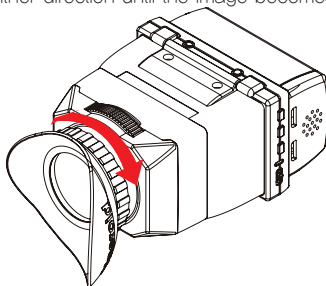

Connecting a HDMI Cable

1. Make sure the EVF input selection is set to HDMI. Please refer to 'Input Selection' on page 13.
2. First connect the mini-HDMI cable to a camera, and then connect the other end into the HDMI IN connection on the EVF.
3. Check whether the image on the LCD is correctly displaying the image on the camera. If the image on the LCD is not displaying correctly, check the cable connections and/or the camera to ensure all settings are correct.

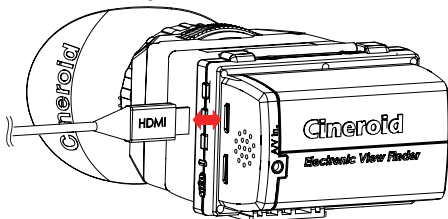

Before Using the EVF

Connecting a Composite Cable

1. Make sure the EVF input selection is set to Composite. Please refer to 'Input Selection' on page 13.
2. You can purchase a composite cable from Cineroid or use your own cable if it is similar to the illustration below.
3. Insert the 3.5mm dia 4-pole plug into the rear of the EVF marked A/V in.
4. Check the image.

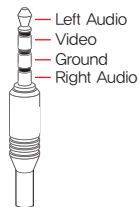
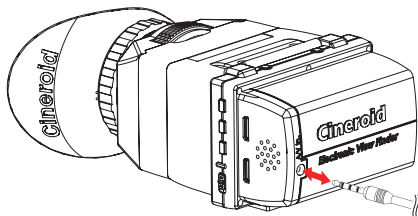

3.5mm dia 4-pole plug

Connecting an External Monitor (EVF4Le)

1. The EVF4Le model provides a HDMI loop-through function. The image on the LCD can be directly looped to an external monitor via a separate mini-HDMI cable.
2. Connect the mini-HDMI input cable to the EVF HDMI in.
3. Connect a separate mini-HDMI cable from the EVF HDMI out to an external monitor.
4. If there is no input signal into the EVF, then there will be no image to the external monitor.
5. The EVF4Be model does not come with a loop-through function.

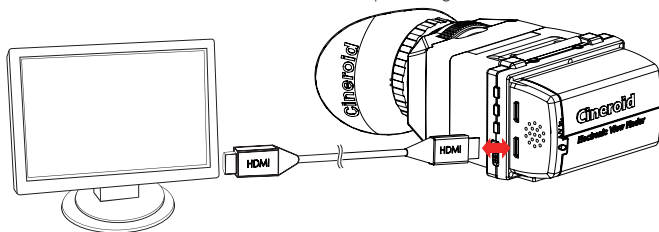

I Basic Features

Operating the Menu

1. Access the setting and features by pressing the menu button on the left side of the EVF.
2. Press the M button to select the main menu. When not in the menu, you can adjust the speaker volume by pressing the up and down arrow keys.

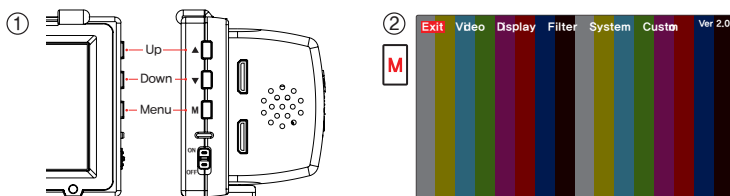

3. Once the main menu is selected, press the up and down arrow keys to navigate through the menu. The cursor is highlighted in red.
4. Move the cursor to the feature you want to select/change and press the M button to access that feature.
5. Press the up and down arrow keys to change the value of the feature.
6. Move the cursor to Exit and press the M button to return to the previous menu.
7. To exit the main menu, Select Exit or press PA button.

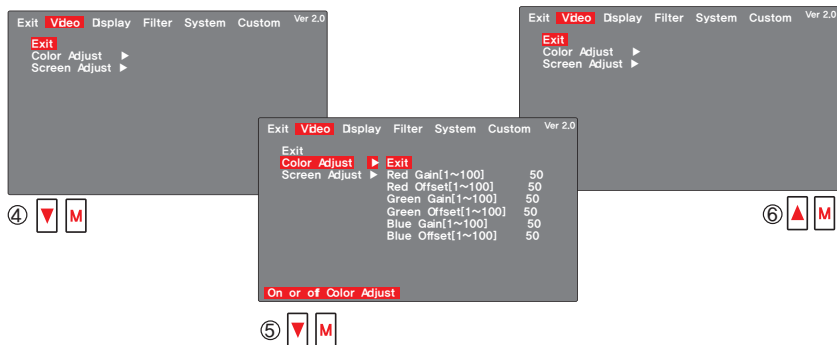

I Basic Features

Input Selection

1. You can choose between composite and HDMI for your external input selection.
2. The HDMI input can receive 480i, 480p, 576p, 720p and 1080i signals.
3. Press the M button for the main menu. Move the cursor to INPUT SELECT and press the M button. Choose either HDMI or Composite.
4. Analog audio is audioable even HDMI input is selected if Analog Audio priority is ON.

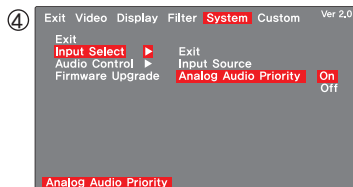
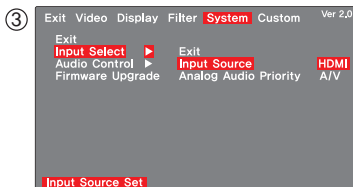

Adjusting Color

1. You can adjust the color of the LCD screen. Choose 1~100 for the color levels.
2. Press the M button for the main menu.
3. Select COLOR ADJUST and choose between Red, Green or Blue to adjust your colors.

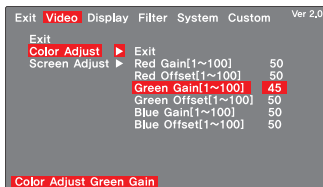
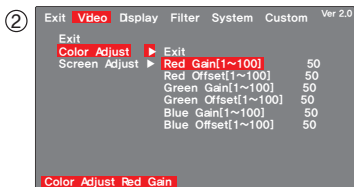

I Basic Features

Adjusting the Screen

1. You can adjust the LCD brightness, contrast, and sharpness. Choose between 1–100 for the brightness and contrast and 1–10 for the sharpness.
2. Press the M button for the main menu.
3. Select SCREEN ADJUST to choose among BRIGHTNESS, CONTRAST, and SHARPEN to adjust your screen.
4. A preview window will appear on the lower right portion of the screen as you adjust your screen.

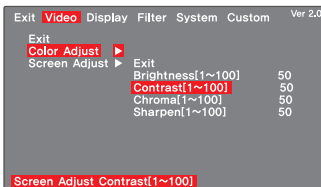
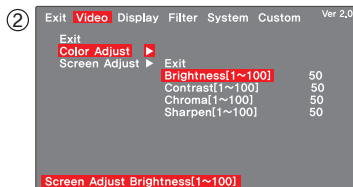

Volume Control

1. The EVF has a built-in speaker on the left side of the body and a headphone jack on the right side.
2. You can adjust the master volume by pressing the up and down arrows on the left side of the EVF when not in the main menu screen. You can also adjust the master volume within the menu. Press the M button for the main menu. Select VOLUME and adjust with the arrow keys.
3. The speaker and headphone volumes can be adjusted independently. To do so, you must adjust the volume within the menu.
4. Audio Level meter is displayed on screen if it is turned on.

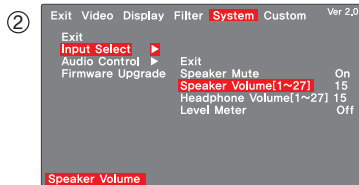
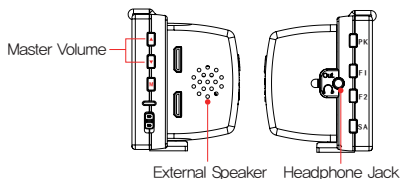

I Shooting Features

Peaking

1. The EVF provides the peaking feature in both the Red and Sharpness mode. The Red mode displays in red and the Sharpness mode displays an outline in white.
2. To activate the peaking feature, simply press the PK button on the left side of the EVF body. The peaking will show in the mode that is currently selected.
3. To change the peaking mode, press the M button for the main menu. Select PEAKING from the menu and then select PEAKING MODE. Select Red or Sharp mode. You can also adjust the peaking threshold by selecting PEAKING THRESHOLD and adjusting accordingly. The threshold range is 1–5 with 5 being the highest.
4. The peaking feature works only with HDMI input. It does not work with Analog input.

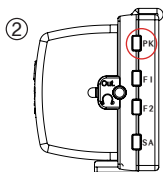

Peaking Red OFF



Peaking Red ON

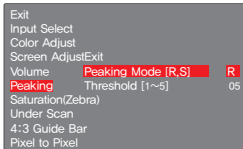

Peaking Mode Set



Peaking Sharpness OFF



Peaking Sharpness ON

Shooting Features

Anamorphic

1. The screen size can be changed for anamorphic lens.
2. The screen size is set for each input resolution.
3. The position of center is adjustable at Offset menu.

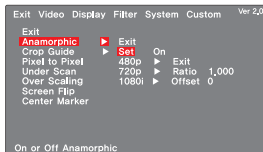

Crop guide

1. The crop guide information is displayed on screen.
2. Ratio can be selected from 4:3, 1.85:1, 16:9, 2:1, 2.35:1, Custom.
3. The size of crop guide can be reduced at Reduce menu. Its range is 0.500~1.000.
4. Guide Line display is optional and transparent(Background) range is 0~8.

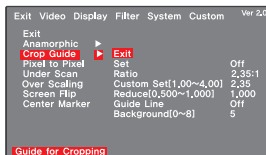

Shooting Features

Over Scaling

1. The image can be stretched to 1.5 times.
2. The aspect ratio of image is not changed. Also, it is set for each resolution, 480p, 720p, 1080i.
3. Image can be moved to vertical or horizontal.

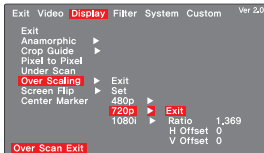

English

Center Marker

1. The center of screen is marked with cross.
2. Color is white and it is changed to black if image is white.



I Shooting Features

Clip guide

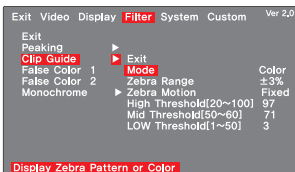

1. There are three Clip guide modes, Color and Zebra, both.
2. Zebra range is selectable among 3%, 5%, 8%, 11%. Also, Zebra mark has two types, moving or fixed.
3. There is three kinds of threshold, High, Middle, Low.

False color

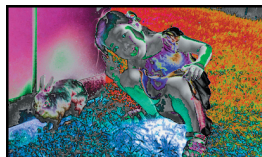
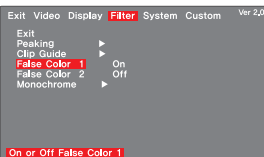

1. False color shows exposure rate with 6 kinds of colors.
2. There are two kinds of False color.

Shooting Features

Firmware Upgrade

1. Firmware is upgradable by special cable.
2. Connect EVF and computer by cable.
3. Select On of Firmware Upgrade. The screen is changed to waiting message.
4. EVF starts firmware upgrade.

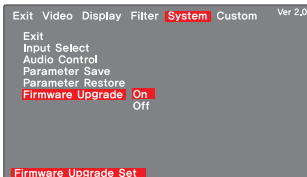

Screen Flip

1. You can flip the video image on the LCD screen 180 degrees vertically or horizontally by activating the screen flip feature.
2. To flip the image horizontally, from the main menu select SCREEN FLIP then turn MIRROR on.
3. To flip the image vertically, from the main menu select SCREEN FLIP then turn ROTATE on.

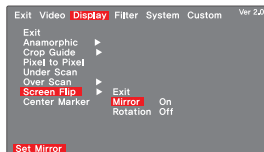

Mirror OFF / Rotate OFF



Mirror ON



Rotate ON / Mirror ON



Rotate ON

Shooting Features

Pixel to pixel

1. Enabling pixel to pixel eliminates the need for you to zoom in/out of your native video.
2. If the native video is larger than the LCD resolution then that creates a zooming effect. Conversely, if the native video is smaller than the LCD resolution then that creates a scale-down effect.
3. The pixel to pixel feature only maps the center of the video image.

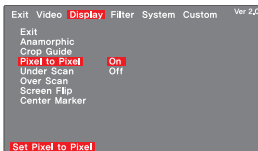

Pixel to Pixel OFF



Pixel to Pixel ON

Underscan

1. You can view every corner of the image on the LCD by activating the underscan feature. You can select the underscan feature from within the main menu or by custom setting the F1 or F2 button.
2. When the underscan feature is activated, the entire image is slightly decreased in size from the original.

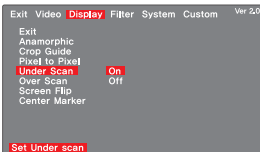

Underscan OFF



Underscan ON

Shooting Features

Monochrome (B/W, Blue, Red, Green)

1. You can view the image on the LCD in B/W by activating the monochrome feature.
The color mode is B/W, Blue, Red, Green.
2. To activate the monochrome feature, press the M button for the main menu, select MONOCHROME and turn the feature on. You can also assign this feature to one of the custom buttons, F1 or F2, in order to activate the feature immediately.

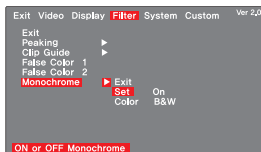

Monochrome (B/W) OFF



Monochrome (B/W) ON

Custom Button Functions

1. The left side of the EVF body contains the buttons PK, F1, F2, SA. The factory default for these buttons are peaking (PK), Pixel to pixel (F1), False color 1 (F2), and Clip guide (SA).
2. Each button can be customized to a particular feature by selecting CUSTOM SETUP on the main menu.
3. Press the M button for the main menu then select CUSTOM SETUP.
4. Select one of the buttons (PK, F1, F2, SA) you wish to customize. Select from one of the features listed to assign that feature to the selected button.
5. Exit out of the menu.

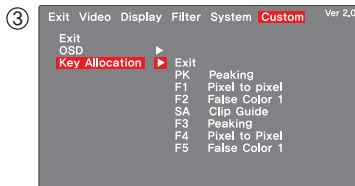
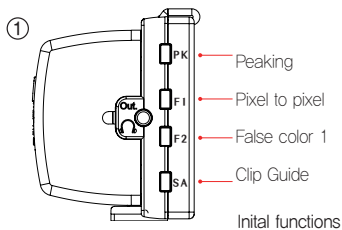

Setting User Controls

Custom Display Settings

1. You can select to view the current state of the battery usage, volume, etc. on the LCD.
2. Press the M button for the main menu and select STATUS DISPLAY to view the options.
3. Select ON or OFF for each item you want to view or not view on the LCD.
4. The pixel to pixel display only appears when the feature is activated.

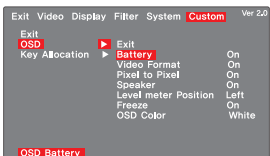

OSD



Pixel to Pixel ON



Peaking ON

Parameter save and restore

1. The all parameters of function can be stored on bank0 or bank1.
2. The parameters can be restored from bank0 or bank2.
3. Factory is the initial parameter of factory.

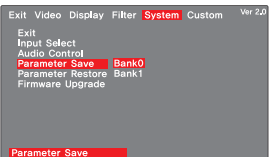

Parameter Save

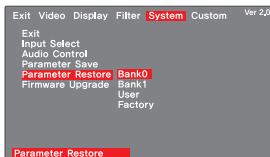

Parameter Restore

Factory reset



1. Powering on the EVF while pressing down the PK button will reset the EVF to its original default settings.
2. Once the factory reset is complete, fully power off the EVF before powering on for further

I Product Specifications

LCD	Size	3.2inch TFT LCD
	Resolution	800 x 480
	Color	16.7M
	Viewing angle	H: 180 degrees, V: 180 degrees
	Display area	69.6(H) x 41.76(V)mm
Input	HDMI	(480i/480p/576p/720p/1080i)
	Composite	Video/Stereo Audio
Video output	HDMI	(480i/480p/576p/720p/1080i)
Audio out	Phone Jack	3.5 ϕ Analog stereo
	Internal speaker	Mono Output
Power	Battery	Small, Medium, Large
	External	DC 6.0 ~ 17V by DC adapter(PA01)
Operating Temperature		-10°C to 60°C
Storage Temperature		-20°C to 70°C
Power consumption		3.5W(4hours with 2200mAH battery)

| Optional Products

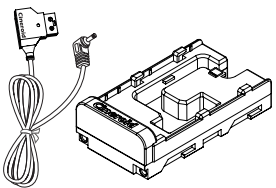
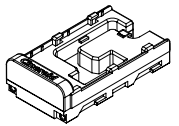
○ External power adapter



PA01 SET (PA01+FCB043)		Power Adapter + DC plug with D-tap
PA01		Power Adapter
FCB043		DC plug with D-tap for PA01
FCB044		DC plug only for PA01

○ Articulating Arm

Model	Length	Form	Material
CA20	20cm (6inch)		금속
CA30	30cm (10inch)		금속

Optional Products

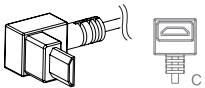
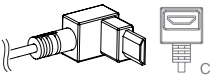
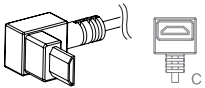
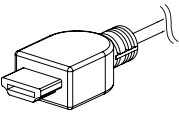
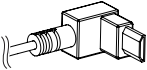

OHDMI Cable

Model	Length	Plug form	
HCRF07CRB	70cm		
HASN12CRF	120cm		
HASN12CRB	120cm		

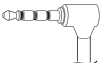

OMini ball head

Model	Weight	Form	Material
Mini ball head MBH-P	40g		Reinforced plastic
Mini ball head MBH-M	80g		Metal

OComposite cable

Model	Length	Plug form	
FCB041	70cm		
FCB042	100cm		RCA x 3EA

| Optional Products

Form	Model
	EVF Remote controller RM01 Trigger functions of EVF by wired Functions are assigned in EVF menu
	EVF Remote controller RM01 Trigger functions of EVF by wired Functions are assigned in EVF menu
	L-clamp Extends $\frac{1}{4}$ " screw mount to 3 positions for EVF4L/B Clamp mini HDMI cable

I MEMO

Cineroid *EVF*

Electronic View Finder

We will strive to create the best products
and provide superb service.

Customer Support Center

Seculine Co., LTD.

Tel +82.2.850.3021 / **Fax** +82.2.850.3027

Rm.510, Kolon Science Valley #2, Guro-dong, 811, Guro-gu, Seoul, 152-878, Korea

Homepage www.cineroid.com

E-mail sales@secu-line.com