

OPERATION MANUAL

HVS-XT100/100OU
HVS-XT110
Digital Video Switcher

4th Edition



Edition Revision History

Edit.	Rev.	Date	Description	Section
1		2013/08/30	1st edition	
2		2013/12/18	Input Expansion Cards for HVS-XT100 Output Expansion Cards for HVS-XT100 FILE page added (WEB control)	2-2-1, 5-10, etc. 2-2-1, 6-6, etc. 21-13
2	1	2014/01/23	Changed to "MU and OU connection cable" from "LAN cable" Added notes on powering on the HVS-XT110 Changed KEY/DSK operation description Changed XT100PCI supported inputs Factual errors corrected	Unpacking, 3-1-1 3-3-2 9-1, 9-2, 9-3, 9-8-1 22-1-1
2	2	2014/03/07	HVS-XT100VR option MV USER PRESET1-8 added to GPI IN RS-422 note added Web-based Control GUI revised (V 1.02.0) Added TRANS RATE settings Added SWIPE INPUT On/Off Added Virtual Link settings	20-1-4 20-2, 20-3, 20-4 21 21-4 21-16-4 21-16-6
2	3	2014/04/15	Changed Temperature	22-1-1
3	-	2014/05/07	HVS-16A/32A/64A units supported Option Setting Files for HVS-XT100/110 added SmartDirect (XT100VR required) supported Changed Temperature	Upon Receipt, 20-6, 22 18-7 21, 22 23-1-1
3	1	2014/05/30	Changed HVS-XT100AO description BRIGHT menu added	6-6-2 13-3, 13-4
4	-	2014/07/31	Added Router Link Supported 3G-SDI and 4K image input/output (HVS-XT100EXP3G)	20-3-9 22



Precautions

Important Safety Warnings



[Power]

 Caution	Operate unit only on the specified supply voltage.
	Disconnect power cord by connector only. Do not pull on cable portion.
 Stop	Do not place or drop heavy or sharp-edged objects on power cord. A damaged cord can cause fire or electrical shock hazards. Regularly check power cord for excessive wear or damage to avoid possible fire / electrical hazards.

[Grounding]

 Caution	Ensure unit is properly grounded at all times to prevent electrical shock hazard.
 Hazard	Do not ground the unit to gas lines, units, or fixtures of an explosive or dangerous nature.
 Caution	Ensure power cord is firmly plugged into AC outlet.



[Operation]

 Hazard	Do not operate unit in hazardous or potentially explosive atmospheres. Doing so could result in fire, explosion, or other dangerous results.
 MHazard	Do not allow liquids, metal pieces, or other foreign materials to enter the unit. Doing so could result in fire, other hazards, or unit malfunction.
	If foreign material does enter the unit, turn power off and disconnect power cord immediately . Remove material and contact authorized service representative if damage has occurred.

[Transportation]

 Caution	Handle with care to avoid shocks in transit. Shocks may cause malfunction. When you need to transport the unit, use the original packing materials or alternate adequate packing.
--	--

[Circuitry Access]

	<p>Do not remove covers, panels, casing, or access circuitry with power applied to the unit! Turn power off and disconnect power cord prior to removal. Internal servicing / adjustment of unit should only be performed by qualified personnel.</p>
 <p>Stop</p>	<p>Do not touch any parts / circuitry with a high heat factor. Capacitors can retain enough electric charge to cause mild to serious shock, even after power is disconnected. Capacitors associated with the power supply are especially hazardous. Avoid contact with any capacitors.</p>
 <p>Hazard</p>	<p>Unit should not be operated or stored with cover, panels, and / or casing removed. Operating unit with circuitry exposed could result in electric shock / fire hazards or unit malfunction.</p>

[Potential Hazards]

 <p>Caution</p>	<p>If abnormal smells or noises are noticed coming from the unit, turn power off immediately and disconnect power cord to avoid potentially hazardous conditions. If problems similar to above occur, contact authorized service representative before attempting to again operate unit.</p>
--	---

[Rack Mount Brackets, Ground Terminal, and Rubber Feet]

 <p>Caution</p>	<p>To rack mount or ground the unit, or to install rubber feet, do not use screws or materials other than those supplied. Otherwise, it may cause damage to the internal circuits or components of the unit. If you remove the rubber feet attached on the unit, do not reinsert the screws securing the rubber feet.</p>
---	---

[Consumables]

 <p>Caution</p>	<p>The consumables used in unit must be replaced periodically. For further details on which parts are consumables and when they should be replaced, refer to the specifications at the end of the Operation Manual. Since the service life of the consumables varies greatly depending on the environment in which they are used, they should be replaced at an early date. For details on replacing the consumables, contact your dealer.</p>
--	--

Upon Receipt

Unpacking

HANABI Series switchers and their accessories are fully inspected and adjusted prior to shipment. Operation can be performed immediately upon completing all required connections and operational settings.

Check your received items against the packing lists below. Check to ensure no damage has occurred during shipment. If damage has occurred, or items are missing, inform your supplier immediately.

HVS-XT110 Packing List

ITEM	QTY	REMARKS
HVS-XT110	1	
AC Adaptor	1 set	
Quick Setup Guide	1	
CD-ROM	1	Operation manual (PDF)

Options

HVS-XT100ARC	1	Arcnet I/F Card
HVS-XT100ED	1	Editor Control Software
HVS-XT100VR	1	Virtual Link Software
HVS-XT100EXP3G	1	3Gbps Expansion Software
HVS-XT110PSM	1	Redundant Power Supply Unit
Rack Mount Brackets	1 set	EIA standard type

HVS-XT100 Packing List

◆ HVS-XT100 (MU) Box

ITEM	QTY	REMARKS
HVS-XT100	1	Switcher Main Unit (MU)
AC cable	1 set	Retaining clips included
Quick Setup Guide	1	
CD-ROM	1	Operation manual (PDF)
Rack Mount Brackets	1 set	EIA standard type

Options

HVS-XT100ARC	1	Arcnet I/F Card
HVS-XT100ED	1	Editor Control Software
HVS-XT100EXP3G	1	3Gbps Expansion Software
HVS-XT100PSM	1	MU Redundant Power Supply Unit
HVS-XT100DI-A	1-2 ^(*)	4 Channel Digital Input Card ^(*)
HVS-XT100AI	1-2 ^(*)	2 Channel Analog Input Card
HVS-XT100PCI	1-2 ^(*)	2 Channel VGA/HDMI Input Card
HVS-XT100DO	1-2 ^(*)	2 Channel Digital Output Card
HVS-XT100AO	1-2 ^(*)	2 Channel Analog Output Card
HVS-XT100PCO	1-2 ^(*)	2 Channel VGA/HDMI Output Card
HVS-XT100VR	1	Virtual Link Software

^(*) Note that installing **two** HVS-XT100DI-A cards adds **six** channels (two channels on the second card) to the switcher.

^(*) Up to **three** input/output cards (up to **two** cards for each) can be installed into the HVS-XT100 units.

◆ **HVS-XT100OU Box**

ITEM	QTY	REMARKS
HVS-XT100OU	1	Switcher Control Panel (OU)
MU and Control Panel connecting cable	1	For HVS-XT100 connection STP (Shielded Twisted pair cable) Cat5e, Straight through, 10m
AC Adapter	1 set	AC cable and retaining clip included

Options

HVS-XT100PSO	1 set	OU Redundant Power Supply Unit
Rack Mount Brackets	1 set	EIA standard type

HANABI Series Options

ITEM	QTY	REMARKS
HVS-30RU	1	Remote Control Unit (via RS-422)
HVS-AUX8	Up to 5 total	AUX bus Control Boxes (HVS-XT100ARC is required)
HVS-AUX16		
HVS-AUX32		
HVS-AUX8RK or HVS-AUXRK	---	Remote Kit for Aux bus Control Boxes
HVS-AUX16A	Up to 5 total	AUX Bus Control Box (Ethernet connection)
HVS-AUX32A		
HVS-AUX64A		
HVS-TALR20/32	Up to 3 total	Tally Control Unit (Relay type) (via RS-422)
HVS-TALOC20/32		Tally Control Unit (Open Collector type) (via RS-422)
Control Cable	1	BNC cable for ARCNET connection (10 m) , (BNC 5C2V 75Ω)

About This Manual

This manual is intended to help the user easily operate Hanabi series switchers and make full use of their functions during operation. Before configuring or operating your system, read this operation manual thoroughly to ensure you understand the product. Afterwards, it is important to keep this manual in a safe place and available for future reference.

Font Conventions

The following conventions are used throughout this manual:

- Boxed text (for example KEY1) is used to indicate control panel **buttons**.
- Bold text (such as **SIGNAL**, **TYPE** and **COLOR**) is used to indicate **setting parameters** in menus and important words.
- Shaded text (such as **ON** and **50.0**) is used to indicate menu **setting values**.
- Text enclosed by square brackets (such as [SETUP - SYSTEM]) indicate **menu names**.

A "**double-press**" is the act of **quickly pressing** a control panel button **twice** in this manual.

Table of Contents

1. Prior to Starting.....	15
1-1. About HVS-XT100 Series Switchers.....	15
1-2. Features	15
2. Panel Descriptions.....	16
2-1. HVS-XT100OU	16
2-2. HVS-XT100	17
2-2-1. Option Slots.....	19
2-3. HVS-XT110	20
2-4. Interfaces.....	22
2-4-1. RS-422 Connector 1-2	22
2-4-2. GPI IN/TALLY OUT Connector	22
3. Connection.....	23
3-1. HVS-XT100 / XT100OU	23
3-1-1. Basic Configuration	23
3-1-2. Installing the Power Cord Retaining Clamp	24
3-1-3. Optional Configuration	25
3-2. HVS-XT110	26
3-2-1. Basic Configuration	26
3-2-2. Optional Configuration	27
3-3. Power ON.....	28
3-3-1. HVS-XT100/XT100OU	28
3-3-2. HVS-XT110	28
3-4. System Signal Format Selection at Initial Use	29
3-5. Setting Date, Time and Time Zone at Initial Use	30
4. Menu Operation.....	31
4-1. How to Access Menus.....	31
4-1-1. Menu Access Buttons	31
4-1-2. Other Menu Access Buttons	32
4-1-3. USER Buttons (Menu Shortcut)	32
4-2. How to Set Values.....	33
4-2-1. Displaying Parameters.....	33
4-2-2. Changing Settings or Values Using F1 to F4.....	34
4-2-3. Changing Settings or Values Using the Numeric Keypad	35
4-2-4. Changing Settings or Values Using the Joystick	36
4-3. How to Return Settings to Default.....	37
4-3-1. Returning Parameters to Default	37
4-3-2. Returning Menus to Default	37
4-4. How to Back up Settings	37
5. Video Sources	38
5-1. How to Assign User Names to Sources.....	38
5-2. How to Assign Sources to Bus Buttons	39
5-3. Resize Function.....	40
5-4. INPUT STILL (Freezing Input Video)	41
5-5. Changing the Side Panel Image	42

5-6. XPT DELAY	42
5-7. Frame Synchronizer.....	43
5-8. Adjusting Video Signal Levels.....	44
5-8-1. Proc Amp	44
5-8-2. Video Level Clip	44
5-9. Bus Matte	45
5-9-1. Setting the Matte Color	45
5-9-2. Setting the Gradient Matte.....	45
5-10. Setting Up Additional Inputs.....	47
5-10-1. HVS-XT100DI-A.....	48
5-10-2. HVS-XT100AI	48
5-10-3. HVS-XT100PCI.....	49
5-10-4. FS, INPUT STILL and Resize Functions	50
6. Video Outputs.....	51
6-1. Aux Outputs	51
6-1-1. Selecting Video via Bus Buttons.....	51
6-1-2. Selecting Video from Menu Selection.....	51
6-1-3. AUX Video Switching with Effects	52
6-2. Preview Set Up	53
6-2-1. Preview Bus Monitoring	53
6-2-2. Setting Up Preview Images	53
6-3. Clean Set Up.....	54
6-4. KEY OUT Set Up	54
6-5. HDMI Output	55
6-6. Setting Up Additional Outputs.....	56
6-6-1. HVS-XT100DO	57
6-6-2. HVS-XT100AO.....	58
6-6-3. HVS-XT100PCO	59
6-6-4. Proc Amp	60
6-6-5. Video Level Clip.....	60
6-7. Safety Area Markers	61
6-8. Ancillary Data	62
6-8-1. Passing Incoming Ancillary Data	62
6-8-2. Ancillary Data in PGM and PREV Bus Signals	62
6-9. AUX LINK.....	63
6-9-1. Creating AUX Output Link Groups	63
6-9-2. Creating Signal Link Groups.....	63
6-9-3. Enabling AUX LINK.....	64
7. Bus Operation	65
7-1. Selecting Video Sources.....	65
7-1-1. Selecting Video Sources on the PGM/PST	65
7-1-2. Selecting Video Sources for AUX1 to AUX4	66
7-1-3. Selecting Video Sources for KEY and DSK.....	66
7-2. Button Switching Mode in the M/E Bus.....	67
7-3. Setting-up and Using the SHIFT Function.....	67
7-3-1. Assigning the SHIFT Function to a Bus Button:.....	67
7-3-2. Using the SHIFT Function	68

8. Transitions	69
8-1. Transition Block Description.....	70
8-2. Quick Reference for Available Transitions.....	70
8-3. Background Transitions.....	71
8-4. KEY Transitions.....	73
8-5. DSK Transitions	75
8-5-1. Where DSK Images Appear.....	75
8-6. Simultaneous BKGD and Key Transitions	76
8-7. Black Transitions	76
8-8. Pattern (WIPE/DVE) Transitions.....	77
8-8-1. Selecting a Pattern.....	77
8-8-2. Use Limitations for Pattern Transitions.....	78
8-8-3. Direct Pattern Function	79
8-8-4. Other Transition Settings	81
8-9. Modifying Patterns.....	82
8-9-1. WIPE Type (No. 0-99).....	82
8-9-2. DVE Type (No. 100-137).....	84
8-10. KEY/DSK Transitions	86
8-10-1. Setting the KEY/DSK Transition Button Function.....	86
8-10-2. USER Transitions.....	87
8-11. Transition Settings.....	88
8-11-1. TRANS Menu	88
8-11-2. Transition Rate	88
8-11-3. Transition Limit.....	89
8-11-4. Adjusting the Fader Offset	89
8-11-5. Endpoint Processing for DVE Transitions.....	89
9. KEY/DSK	90
9-1. Creating a Luminance Key.....	91
9-2. Creating a Full Key.....	92
9-3. Creating a Bus Key	92
9-3-1. Key Link.....	93
9-3-2. KEY INSERT MATT	93
9-4. Adjusting the Key Signal	94
9-5. Changing KEY or DSK Layer Order.....	94
9-6. Mask and Invert.....	95
9-6-1. Inverting Key and Background.....	95
9-6-2. Key Masks.....	95
9-7. Key Edge.....	97
9-8. DVE Effects on KEY/DSK	98
9-8-1. How to Enable 2D DVEs.....	98
9-8-2. Changing Position and Size.....	99
9-8-3. Changing the Aspect Ratio	100
9-8-4. FADE	100
9-8-5. Rotation	101
9-8-6. CROP.....	103
9-8-7. BORDERS.....	104
10. Chromakey	105

10-1. Creating a Chromakey	105
10-2. Adjusting Chromakey	107
10-2-1. Adjusting Key Levels.....	107
10-2-2. Adjusting the Foreground Image (Chromakey Color)	108
10-2-3. Adjusting Edges	109
10-3. Chromakey Menu.....	110
10-3-1. [CHR KEY - ADJUST] Menu.....	110
10-3-2. [CHR KEY - MATT] Menu.....	111
10-3-3. [CHR KEY - FORGND] Menu.....	112
10-3-4. Resetting Chromakey Settings.....	112
10-4. Assigning the Chromakey to Another KEY or DSK.....	113
10-5. Sending Chromakey Signals to Other Devices	113
11. SUB EFFECT Channel	114
11-1. Selecting a SUB EFFECT Channel and Source Signal	114
11-2. MONO COLOR	114
11-3. DEFOCUS.....	114
11-4. PAINT COLOR.....	115
11-5. FREEZE, STROBE, NEGA, MOSAIC	115
12. Still and Clip Store.....	116
12-1. Managing Still Images.....	116
12-1-1. Capturing Stills.....	116
12-1-2. Displaying Still Images.....	116
12-1-3. Backing-up Stills	117
12-2. Managing Clips	118
12-2-1. Clip Recording	118
12-2-2. Playing Clips	120
12-2-3. Clearing Clip Data.....	121
12-3. Backing-up Still and Clip Data using USB Flash Drive.....	122
12-3-1. Structure for Backing Up Still and Clip Data.....	122
12-3-2. Setting Automatic Backup to ON	123
12-3-3. Manually Loading Backup Data	123
12-3-4. Deleting Backup Data	124
12-3-5. Automatic Loading at Startup	124
12-4. Transferring Image Files	125
12-4-1. LAN Connection.....	125
12-4-2. Image files.....	126
12-4-3. Sending / Receiving Still Images	128
12-4-4. Sending Images to Clip Memory	129
12-5. CG WIPE.....	130
12-5-1. CG WIPE Operation Example 1	131
12-5-2. Saving CG WIPE Settings	132
12-5-3. CG WIPE Menu Quick Reference	132
13. Multiviewer	133
13-1. Assigning the Multiviewer to an Output Bus	133
13-2. Selecting the Split-screen Type	133
13-3. Video Signal Mapping	134
13-4. Setting Up Each Split Area	135

13-4-1. Titles	135
13-4-2. Audio Level Meter	136
13-4-3. Safety Area.....	136
13-4-4. Frame Border	137
13-4-5. On-air Tally.....	137
13-5. Saving / Loading Screen Layouts	138
13-5-1. Saving a Screen Layout.....	138
13-5-2. Loading a Screen Layout	138
13-5-3. Deleting Screen Layout Data	138
14. USER Buttons	139
14-1. USER Button Operation	139
14-2. Triggering User Buttons	143
15. Event Memory	145
15-1. Storing Events	145
15-2. Recalling Events.....	146
15-3. Protecting / Deleting Event Data	147
15-4. Event Data.....	148
15-4-1. Data Not Saved in Events.....	148
15-4-2. Detailed Data Selection for Saving Events	148
15-4-3. Setting the User Default Menu when Storing an Event	149
15-4-4. Detailed Data Selection for Loading Events	149
15-5. Transitions Using Event Recall	150
15-6. Loading an Event at Start-up	151
16. Macros	152
16-1. Recording Macros	152
16-2. Executing Macros.....	153
16-2-1. Operation Example 1	153
16-2-2. Operation Example 2	154
16-2-3. Operation Example 3 (Using KEY/AUX Bus Buttons)	154
16-2-4. Operation Example 4 (Using Macro Attach Buttons).....	154
16-3. Macro Memory Operation	155
16-3-1. Overwrite Protection.....	155
16-3-2. Naming Macros	155
16-3-3. Deleting Macros	156
16-4. Macro Execution Buttons	157
16-4-1. Changing KEY/AUX Bus Buttons to Macro EXE Buttons.....	157
16-4-2. Macro Attach and Macro Detach	158
17. File Operation	159
17-1. USB Flash Drive.....	159
17-2. Supported Files	159
17-3. Saving Data to USB Flash Drives	160
17-4. Loading Data from USB Flash Drives	161
17-4-1. Loading Setting Data.....	161
17-4-2. Downloading Image Files.....	161
17-5. Moving between USB Flash Drive Directories.....	162
17-6. Deleting Files from USB Flash Drives.....	163
17-7. Renaming Files in USB Flash Drives.....	163

18. System Setup Settings.....	164
18-1. Selecting System Signal Format.....	164
18-2. Crosspoint Switch Timing	164
18-3. Selecting a Reference Signal.....	165
18-3-1. To Set Reference Input.....	165
18-3-2. To Set Reference Output.....	165
18-4. Setting Date, Time and Time Zone.....	165
18-4-1. Setting Time Using SNTP (Time) Server.....	166
18-5. Buzzer, Brightness and Screen Saver.....	167
18-6. Status Information.....	168
18-6-1. Checking Alarm Status	168
18-6-2. Verifying Versions	169
18-6-3. Installed Options	169
18-7. Upgrading an Operational Version	171
18-7-1. Upgrade Procedure.....	171
18-7-2. Upgrading the Switcher	172
18-7-3. Loading Setting Data	172
19. Reboot and Initialize.....	173
19-1. Rebooting System.....	173
19-2. System Initialization	173
20. External Device Connection.....	174
20-1. GPI IN/OUT and Tally Outputs	174
20-1-1. GPI IN/TALLY OUT Connector.....	174
20-1-2. Pin Assignment Examples	175
20-1-3. Sending Tally Signals to Tally Units	178
20-1-4. GPI / Tally Function List.....	179
20-2. VTR / VDCP Control	183
20-2-1. RS-422 Port Settings (VTR/VDCP)	183
20-2-2. Controlling the VTR.....	184
20-2-3. Playback and Recording.....	185
20-2-4. VDCP Operation	186
20-3. Router Control.....	191
20-3-1. RS-422 Port Settings	191
20-3-2. Setting MFR Link	192
20-3-3. Crosspoint Switches Using the Menu.....	192
20-3-4. Crosspoint Switches with Control Buttons (Setup).....	193
20-3-5. Crosspoint Switches with Control Buttons (Execution)	194
20-3-6. Displaying Destination / Source Settings.....	194
20-3-7. Saving and Loading Crosspoints.....	195
20-3-8. Simultaneous Switching Using Take	196
20-3-9. Router Link.....	197
20-4. Editor Control (HVS-XT100ED)	199
20-4-1. RS-422 Port Settings	199
20-4-2. Editor Control Settings.....	199
20-4-3. Editor ON/OFF	200
20-5. AUX Bus Control Box (HVS-AUX8/16/32).....	201
20-5-1. Connecting AUX Boxes	201

20-6. AUX Bus Control Box (HVS-AUX16A/32A/64A)	202
20-6-1. Connecting AUX Boxes	202
20-6-2. Assigning Actions to AUX Box Buttons	203
20-6-3. Assigning the SHIFT or TAKE Function	204
20-6-4. Adjusting Light Levels for AUX Box Buttons	205
20-7. Remote Panel (HVS-30RU)	206
20-7-1. RS-422 Port Settings (HVS-30RU)	206
20-7-2. Assigning Sources to PGM/PST Bus Buttons	206
20-7-3. Setting USER Buttons	207
21. SmartDirect Control (Option)	208
21-1. Connecting to SmartDirect via Ethernet	208
21-2. Executing Direct Buttons	209
21-2-1. Executing in the Menu	209
21-2-2. Executing Using Macros	209
22. 3G-SDI Signals (HVS-XT100EXP3G)	210
22-1. Selecting 3G-SDI Format	210
22-2. 4K Mode	210
22-2-1. 4K Image Input / Output Settings	210
22-2-2. KEY/DSK Display	212
22-2-3. 4K Key Link	212
22-2-4. Controlling External DSK Devices	213
22-2-5. 4K GPI IN / TALLY OUT / AUX Action Buttons	213
23. Web-based Control (Ver. 1.02.0-)	214
23-1. System Setup	214
23-2. HOME	215
23-3. TRANS	216
23-4. BUS TRANS	216
23-5. WIPE PATTERN	218
23-5-1. WIPE PATTERN - WIPE/DVE/Other	218
23-5-2. WIPE PATTERN - DIRECT	218
23-6. WIPE MODIFY	219
23-7. KEY and DSK	220
23-8. COPY SWAP (Web Control Only)	221
23-9. CHROMAKEY	222
23-10. SUB EFF	223
23-11. STILL	224
23-11-1. Still Store and Still Capture	224
23-11-2. Play Clips	225
23-11-3. Backing Up/Loading Stills	226
23-11-4. Backing-up Still and Clip Data using USB Flash Drive	226
23-12. MATTE	228
23-13. FILE	229
23-13-1. Uploading a Still Image	229
23-13-2. Uploading a Clip Data (Sequential Image Files)	229
23-13-3. Uploading a Setting File	229
23-14. EVENT	230
23-15. MACRO	231

23-15-1. To Execute Macros	231
23-15-2. To Edit Macros (Web Control Only).....	231
23-15-3. Assigning a Macro to a KEY/AUX Bus Button.....	232
23-16. SETUP	233
23-16-1. SETUP - SYSTEM	233
23-16-2. SETUP - INPUT	234
23-16-3. SETUP - OUTPUT	235
23-16-4. SETUP - PANEL	237
23-16-5. SETUP - GPI/TLY	238
23-16-6. SETUP - FUNCTION	239
23-16-7. SETUP - STATUS.....	241
23-17. EXT IF	242
23-17-1. EXT IF - EDITOR (Option).....	242
23-17-2. EXT IF - TSL TLY	242
23-17-3. EXT IF - VTR/VDCP	242
23-17-4. EXT I/F - ROUTER	246
23-17-5. EXT I/F - ROUTER LINK	249
23-17-6. EXT IF - AUX UNIT	250
23-18. Pop-up Menu Operation.....	251
23-18-1. Menu Shortcuts.....	251
23-18-2. Executing User Buttons	251
23-18-3. Setting Parameters to Default.....	252
23-19. Backing Up Settings.....	252
24. Specifications and Dimensions	253
24-1. Specifications	253
24-1-1. HVS-XT100.....	253
24-1-2. HVS-XT100OU	255
24-1-3. HVS-XT110.....	256
24-2. External Dimensions	258
24-2-1. HVS-XT100.....	258
24-2-2. HVS-XT100OU	259
24-2-3. HVS-XT110.....	260
Appendix 1. Supported File Types	261
Appendix 2. Transition Pattern List	262
Index	

1. Prior to Starting

1-1. About HVS-XT100 Series Switchers

HVS-XT100 series HANABI switchers are powerful and compact 1M/E video switchers that are easy to use. They can be used in all types of locations, including at live and sporting events, in news studios, OB vans, editorial offices and presentation venues, making it the ideal tool for shaping the imaginative ideas of video creators.

1-2. Features

<HVS-XT100>

- Compact HD/SD 1M/E switcher: Main Unit 2U in height
- Switcher Processor (Main Unit) and separate Control Panel
- HD/SD-SDI 8-input/4-output and single HDMI output, expandable up to 14-input/9-output
- Analog and HDMI input/output can be added.
- Frame synchronizer on all inputs
- Redundant Power Supply (with HVS-XT100PSM and HVS-XT100PSO options)

<HVS-XT110>

- Compact HD/SD 1M/E switcher (3U)
- Switcher Processor and integrated Control Panel
- HD/SD-SDI 12-input/8-output and single HDMI output
- Frame synchronizer on IN01 to IN08
- Redundant Power Supply (with HVS-XT110PSM option)

<HVS-XT100/XT110>

- Resizing engine on IN05 to IN08
- 3G-SDI and 4K(Ultra HD) image input/output available with an HVS-XT100EXP3G option
- Built-in multiviewer output, supporting various multi-view layouts with title, tally and audio meter display
- 2-Key and 2-DSK channels
- Chromakey generator
- More than 130 of transition patterns including 2D DVE
- 4-channel DVE for Background, Keys and DSKs
- Two upstream effect channels
- Transition effects using event-load or AUX-signal switch
- Two still stores and two clip stores (approx. 7.5 sec on HD) with backup and data transfer capabilities
- Safety area markers
- Internal color-bar generator
- Various interfaces
 - VTR, Router, Editor and/or Tally Unit connection (RS-422)
 - Aux Bus Control Box connection (Arcnet LAN)
 - Windows PC, Mac computer, tablet, etc. connection for Web-based control and image data transfer (Ethernet LAN)
- Optional Remote Panel (HVS-30RU)

2. Panel Descriptions

2-1. HVS-XT100OU

◆ Control Panel

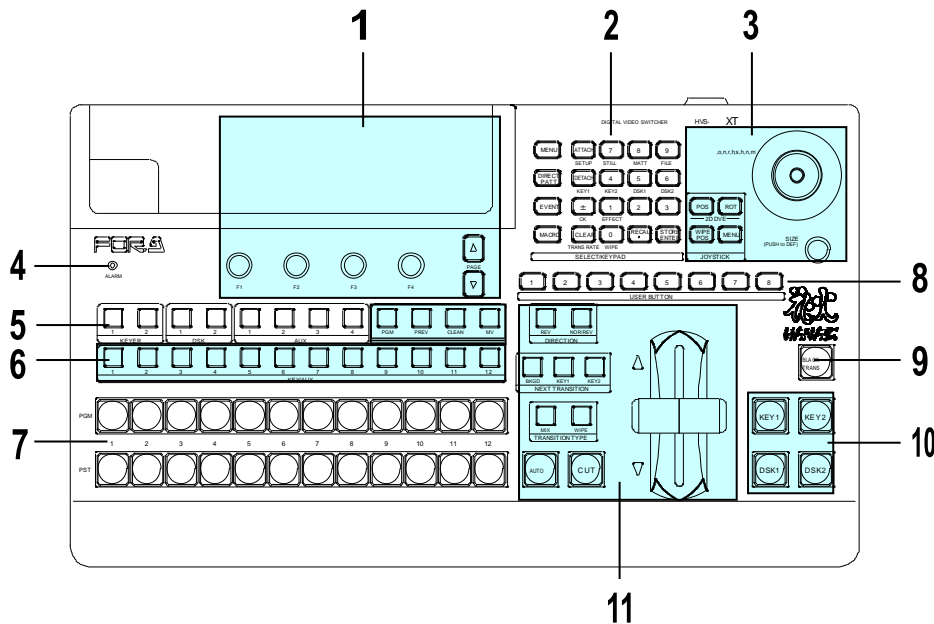

No.	Name	Description	Refer to sec.
1	Menu Control Block	Composed of the menu display, menu control push-buttons (F1 to F4) and page up/down buttons.	4
2	SELECT/KEYPAD Block	Multi-function keypad. Four control buttons (MENU, DIRECT PATT, EVENT, and MACRO) on the left side change the keypad operation mode, in which 12 buttons are used for menu display and input, transition pattern selection, event and macro operations.	4-1-1 4-2-3 8-8-3 15 16
3	JOYSTICK Block	Used to set position, size or color settings in the specific menu parameters.	4-2-4
4	ALARM indicator	Indicates fan alarm status. Normally unlit, the indicator blinks red when an alarm occurs. In such case, power off the system and consult your FOR-A supplier. (It also blinks red when a power supply does not work in redundant configuration.)	18-6-1
5	BUS SELECT Block	Used to select a bus, then to select a video in the KEY/AUX bus (No 7).	6
6	KEY/AUX Bus	Used to select video for the bus selected in the BUS SELECT block (No. 6). The video can be selected from KEY/AUX bus buttons, PGM, PREV, CLEAN and MV.	7 9 13-1
7	PGM/PST (M/E) Bus	Used to select video for the background.	5
8	USER BUTTON	User assignable buttons. Menu shortcuts or functions can be assigned to these buttons.	14
9	BLACK TRANS	Used to perform black transitions.	8-6
10	KEY/DSK Transition Block	Used to perform Key/DSK transitions.	8-4 8-5
11	Transition Block	Used to perform background and key transitions.	8

◆ Rear Panel

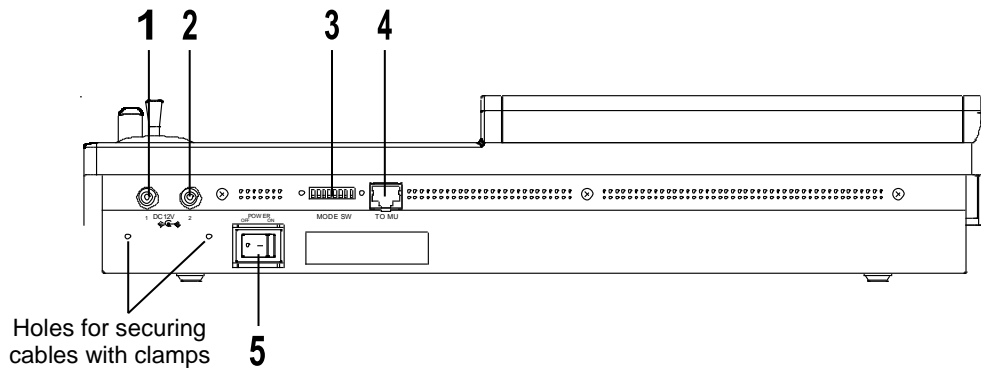

No.	Name	Description	Refer to sec.
1	DC IN1	Supply power (12 V DC) using the supplied AC adapter.	3-1-2
2	DC IN2	Optional power supply (HVS-XT110PSM) for power redundancy. Supply power (12 V DC) using the supplied AC adapter.	3-1-2
3	MODE SW	For maintenance use. Do not change.	
4	TO MU		
5	Power Switch	Switch used to turn unit power ON / OFF.	3-3

2-2. HVS-XT100

◆ Front Panel

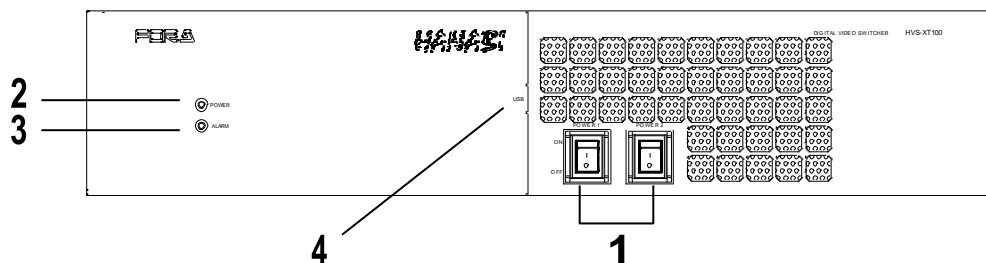

No.	Name	Description	Refer to sec.
1	Power switch1 Power switch2	Switch used to turn unit power ON / OFF. Set both switches to ON if redundant power supply is configured.	
2	POWER indicator	Power indication is lit green when power switch is set to ON and power is applied to unit.	
3	ALARM indicator	Indicates fan alarm status. Normally unlit, the indicator blinks red when an alarm occurs. In such case, power off the system and consult your FOR-A supplier. (It also blinks red when a power supply does not work in redundant configuration.)	18-6-1
4	USB MEMORY	Used to connect a USB flash drive for image file import / export or system setting backup. (USB1.1, Type-A)	12-3 17

◆ Rear Panel

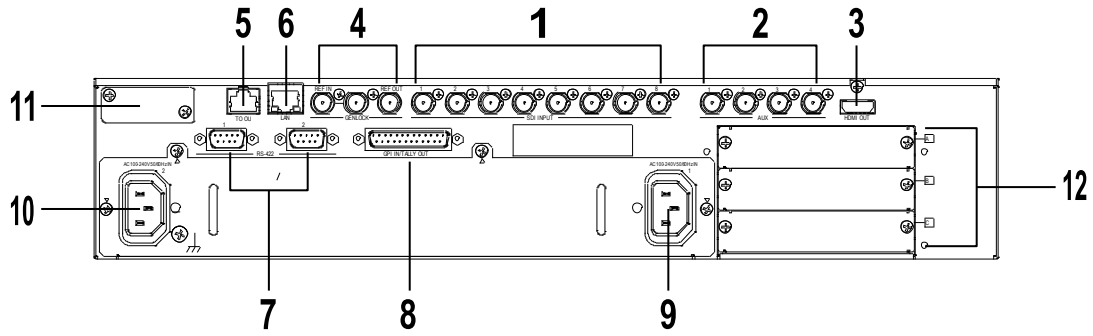

No.	Name	Description	Refer to sec.
1	SDI INPUT	Used to input HD/SD SDI video signal. 8 inputs (BNC)	5
2	SDI OUTPUT	Used to output HD/SD SDI video signal. 4 outputs (AUX1-4) (BNC)	6
3	HDMI	Used to output an HDMI output. (Type A connector)	6-5
4	GENLOCK (REF IN REF OUT)	Used to input and output a genlock signal; tri-level sync or black burst. (BNC) The center terminal is used for loopthrough connection. It must be 75-ohm terminated if not looped-through.	18-3
5	TO OU	Used for HVS-XT100OU connection (RJ-45) Use the MU and OU connection cable supplied with the HVS-XT100OU to connect to the HVS-XT100OU.	
6	LAN	Ethernet port used for image transport and web control 100BASE-TX/1000BASE-T (RJ-45)	12-4-1 21
7	RS-422 (1) RS-422 (2)	Used to connect peripheral devices such as HVS-30RU, VTR/VDCP devices, Routers. (9-pin D-sub, female)	2-4-1
8	GPI IN/ TALLY OUT	Used for GPI input/output and Tally output. (25-pin D-sub, female)	20-1-1
9	AC IN1	Used for connection to AC power source via supplied accessory cord. (AC 100V-240V 50/60Hz) Be sure to ground the protective earth terminal before turning on power to the system to prevent electrical shock. Use the attached cord clamp to secure the power cord.	
10	AC IN2	Optional power supply for power redundancy. Used for connection to AC power source via supplied accessory cord. (AC 100V-240V 50/60Hz) Be sure to ground the protective earth terminal before turning on power to the system to prevent electrical shock. Use the attached cord clamp to secure the power cord.	
11	ARCNET	Optional Arcnet LAN port (HVS-XT100ARC). One port is used for HVS-AUX bus Control Box connection. The other port is used for loopthrough connection. It must be 75-ohm terminated if not looped-through.	20-5-1
12	Option card slots	Used for installing input /output expansion cards.	

2-2-1. Option Slots

All expansion cards can be fitted via the rear of the main unit.
The right three slots are dedicated to these optional cards.

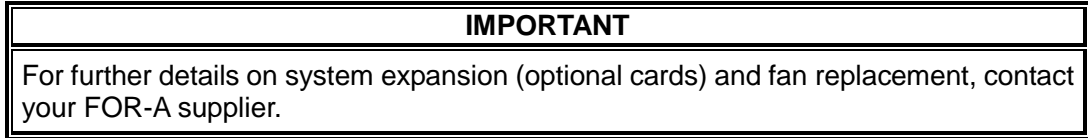

◆ Slots for Option Cards at Rear Panel of Main Unit

Up to 2 additional input cards can be installed into slots A and B.

Up to 2 additional output cards can be installed into slots B and C.

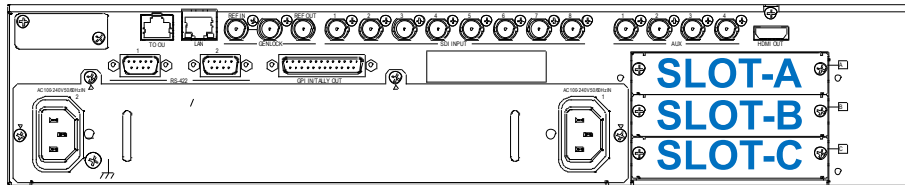

Option slot	Available card	Available video signal (Connector)	Number of inputs/outputs per card
A (IN)	HVS-XT100DI-A	HD/SD SDI (BNC)	4 inputs
	HVS-XT100AI	HD/SD analog component or Analog composite (BNC)	2 inputs
	HVS-XT100PCI	Digital RGB (HDMI) or Analog RGB (VGA)	2 inputs
B (IN/OUT)	HVS-XT100DI-A	HD/SD SDI (BNC)	2 inputs
	HVS-XT100AI	HD/SD analog component or Analog composite (BNC)	2 inputs
	HVS-XT100PCI	Digital RGB (HDMI) or Analog RGB (VGA)	2 inputs
	HVS-XT100DO	HD/SD SDI (BNC)	2 channels 4 outputs
	HVS-XT100AO	HD/SD analog component or Analog composite (BNC)	2 outputs
	HVS-XT100PCO	Digital RGB (HDMI), Analog RGB (VGA), or Analog YPbPr (VGA)	2 channels 3 outputs
C (OUT)	HVS-XT100DO	HD/SD SDI (BNC)	2 channels 4 outputs
	HVS-XT100AO	HD/SD analog component or Analog composite (BNC)	2 outputs
	HVS-XT100PCO	Digital RGB (HDMI), Analog RGB (VGA), or Analog YPbPr (VGA)	2 channels 3 outputs

See section 5-10. "Setting Up Additional Inputs" for more details.

See section 6-6. "Setting Up Additional Outputs" for more details.

2-3. HVS-XT110

◆ Control Panel

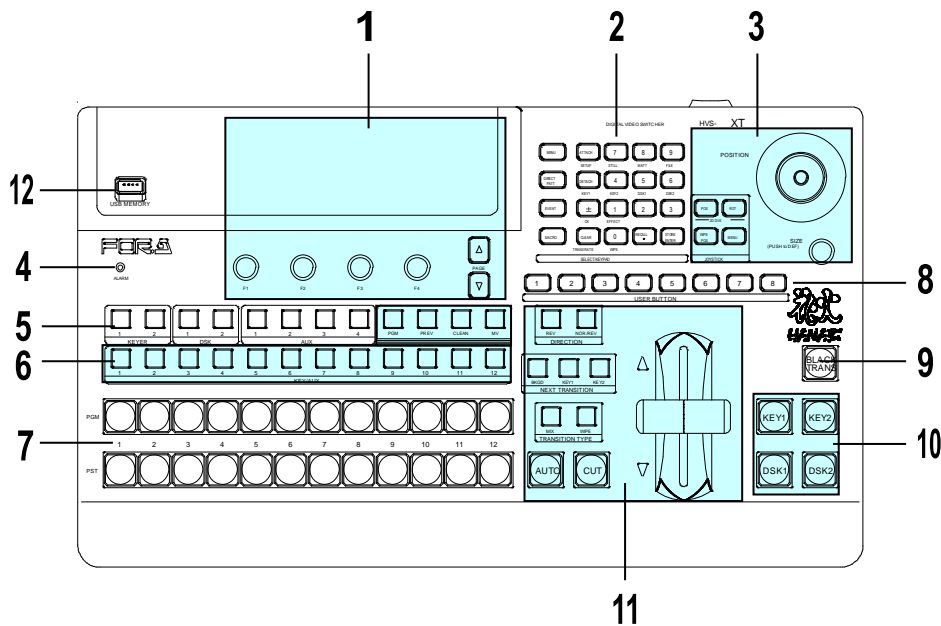

No.	Name	Description	Refer to sec.
1	Menu Control Block	Composed of the menu display, menu control push-buttons (F1 to F4) and page up/down buttons.	4
2	SELECT/KEYPAD Block	Multi-function keypad. Four control buttons (MENU, DIRECT PATT, EVENT, and MACRO) on the left side change the keypad operation mode, in which 12 buttons are used for menu display and input, transition pattern selection, event and macro operations.	4-1-1 4-2-3 8-8-3 15 16
3	JOYSTICK Block	Used to set position, size or color settings in the specific menu parameters.	4-2-4
4	ALARM indicator	Indicates fan alarm status. Normally unlit, the indicator blinks red when an alarm occurs. In such case, power off the system and consult your FOR-A supplier.	18-6-1
5	BUS SELECT Block	Used to select a bus, then to select a video in the KEY/AUX bus (No 7).	6
6	KEY/AUX Bus	Used to select video for the bus selected in the BUS SELECT block (No. 6). The video can be selected from KEY/AUX bus buttons, PGM, PREV, CLEAN and MV.	7 9 13-1
7	PGM/PST (M/E) Bus	Used to select video for the background.	5
8	USER BUTTON	User assignable buttons. Menu shortcuts or functions can be assigned to these buttons.	14
9	BLACK TRANS	Used to perform black transitions.	8-6
10	KEY/DSK Transition Block	Used to perform Key/DSK transitions.	8-4 8-5
11	Transition Block	Used to perform background and key transitions.	8
12	USB MEMORY	Used to connect a USB flash drive for image file import / export or system setting backup. (USB1.1, Type-A)	12-3 17

◆ Rear Panel

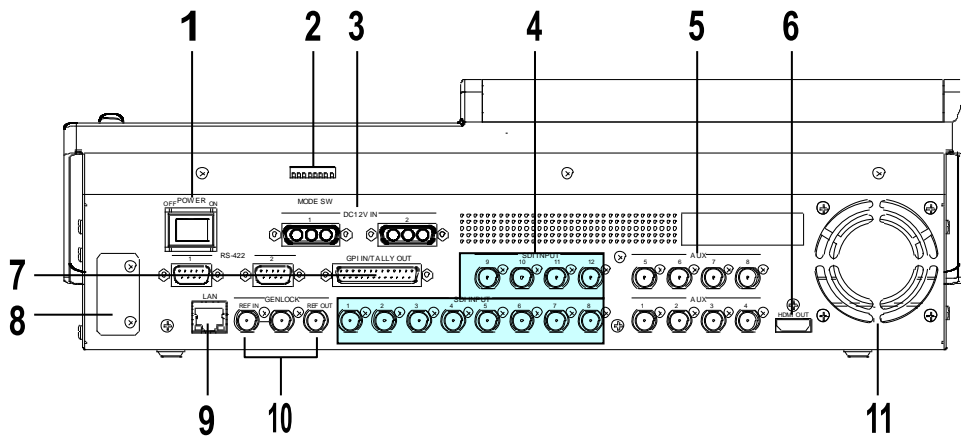

No.	Name	Description	Refer to sec.
1	Power Switch	Switch used to turn unit power ON / OFF.	
2	MODE SW	For maintenance use. Do not change.	
3	DC IN1	Supply power (12 V DC) using the supplied AC adapter.	3-3
	DC IN2	Optional power supply (HVS-XT110PSM) for power redundancy. Supply power (12 V DC) using the supplied AC adapter.	
4	SDI INPUT	Used to input HD/SD SDI video signal. 12 inputs (BNC)	5
5	SDI OUTPUT	Used to output HD/SD SDI video signal. 8 outputs (AUX1-8) (BNC)	6
6	HDMI	Used to output an HDMI output. (Type A connector)	6-5
7	RS-422 (1)	Used to connect peripheral devices such as HVS-30RU, VTR/VDCP devices, Routers. (9-pin D-sub, female)	2-4-1
	RS-422 (2)		
	GPI IN/ TALLY OUT	Used for GPI input/output and Tally output. (25-pin D-sub, female)	20-1-1
8	ARCNET	Optional Arcnet LAN port (HVS-XT100ARC). One port is used for HVS-AUX bus Control Box connection. The other port is used for loopthrough connection. It must be 75-ohm terminated if not looped-through.	20-5-1
9	LAN	Ethernet port used for image transport and web control 100BASE-TX/1000BASE-T (RJ-45)	12-4-1 21
10	GENLOCK (REF IN REF OUT)	Used to input and output a genlock signal; tri-level sync or black burst. (BNC) The center terminal is used for loopthrough connection. It must be 75-ohm terminated if not looped-through.	18-3
11	Cooling Fan	Used to air cool the unit to prevent overheating. Do not block the ventilation openings.	18-6-1

2-4. Interfaces

2-4-1. RS-422 Connector 1-2

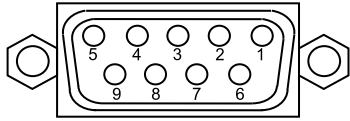

◆ Pin Assignment Table (9-pin D-sub, female, with inch screws)

Pin No.	Signal Name	In/Out	Description
1	FG		Frame ground
2	R-	In	Receive data (-)
3	T+	Out	Transmit data (+)
4	SG		Signal ground
5	NC		Not used
6	SG		Signal ground
7	R+	In	Receive data (+)
8	T-	Out	Transmit data (-)
9	FG		Frame ground

RS-422 ports are used for the following device connections. See the related chapters to configure the connections.

- HVS-30RU:** See section 20-6. "Remote Panel (HVS-30RU)."
- Tally Units:** See section 20-1-3. "Sending Tally Signals to Tally Units."
- VTR/VDCP devices:** See section 20-2. "VTR / VDCP Control."
- Routers:** See section 20-3. "Router Control."
- Editor:** See section 20-4 "Editor Control."

2-4-2. GPI IN/TALLY OUT Connector

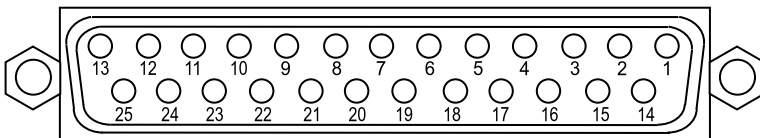

◆ Pin Assignment Table (25-pin D-sub, female, with inch screws)

Pin No.	Description
1	BKGD AUTO TRANS (input) (default setting)
2	KEY1 AUTO TRANS (input) (default setting)
3	KEY2 AUTO TRANS (input) (default setting)
4	DSK1 AUTO TRANS (input) (default setting)
5	DSK2 AUTO TRANS (input) (default setting)
6-24	Unassigned (default setting)
25	Frame ground

► See section 20-1-1. "GPI IN/TALLY OUT Connector" for more details.

3. Connection

3-1. HVS-XT100 / XT100OU

3-1-1. Basic Configuration

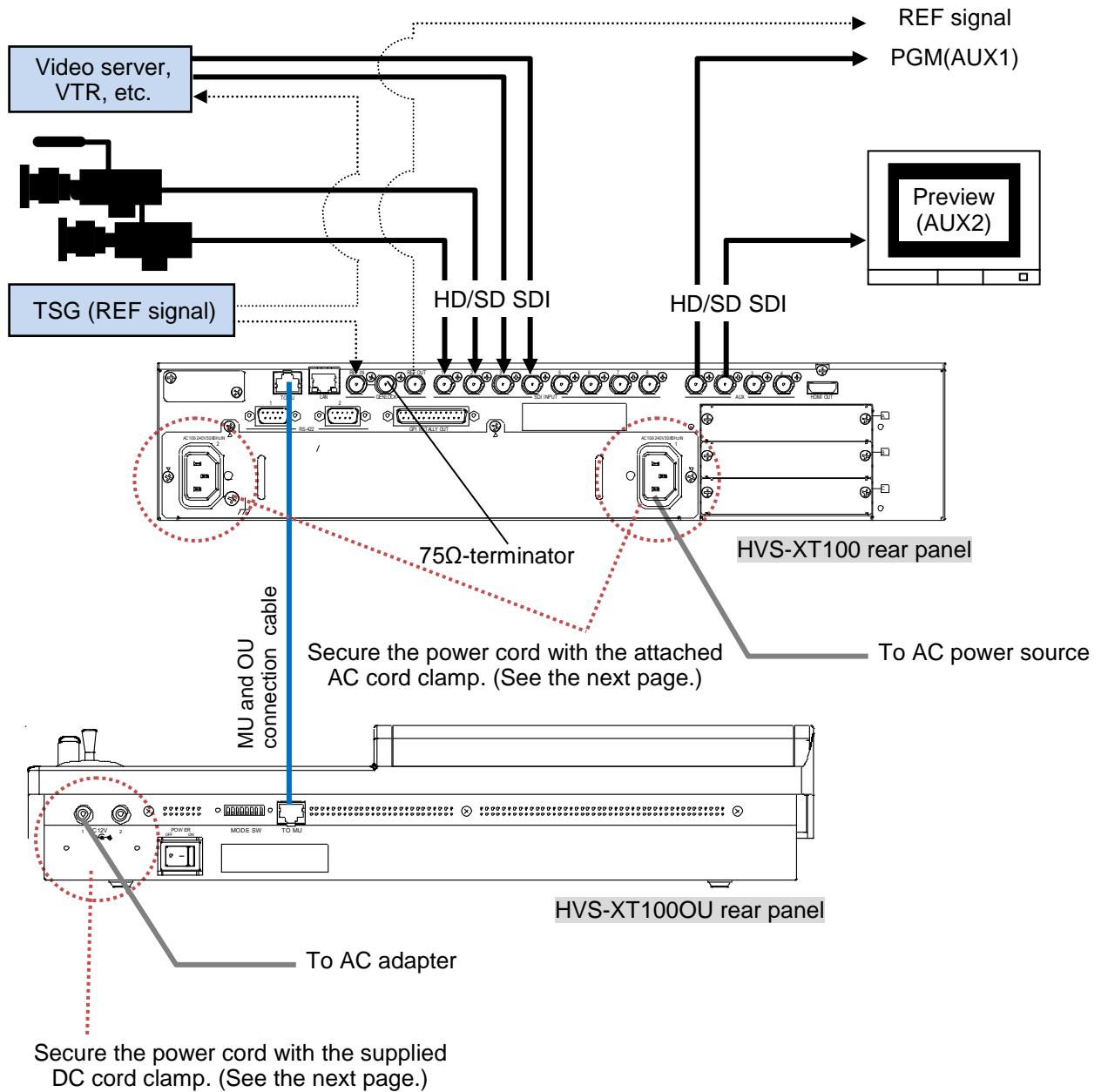

- ▶ See section 18-3. "Selecting a Reference Signal" for details on setting a reference signal.
- ▶ See section 6-2. "Preview Set Up" for details on displaying preview image.

3-1-2. Installing the Power Cord Retaining Clamp

◆ AC cord clamp

Installation

- 1) Wrap the retaining clamp around the AC cord (with the anchor of the ladder strap toward the unit).
- 2) Insert the anchor into the hole next to the AC IN socket.
- 3) Lightly fasten the clamp around the AC cord.
- 4) Plug in the power cord.
- 5) Slide the clamp on the ladder strap toward the plug.
- 6) Fasten the clamp tightly.
- 7) Gently pull on the AC cord to ensure it is secured.

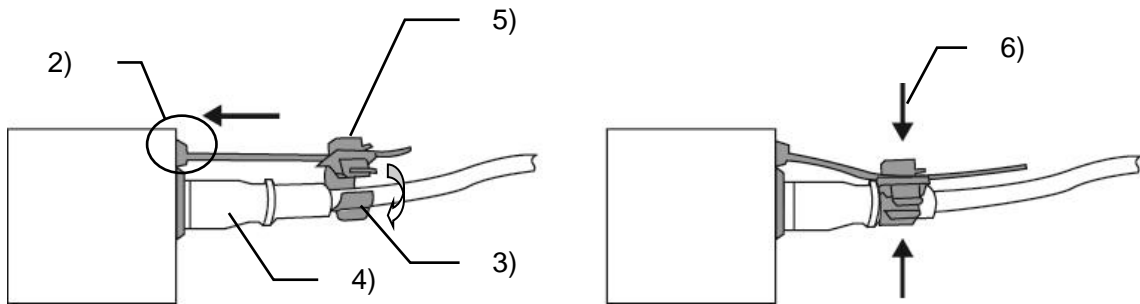

Uninstallation

- 1) Push the tab on the retaining up to unfasten the clamp.
- 2) Push the tab on the ladder strap up and slide the clamp back.
- 3) Unplug the AC cord.

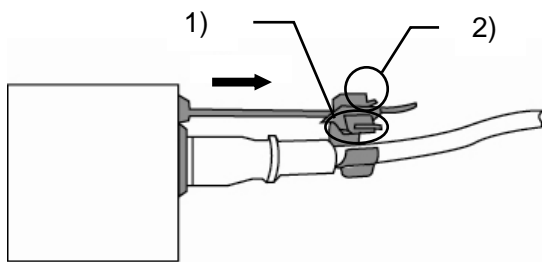

◆ DC Cord Clamp Installation

Insert the DC cord into the DC IN connector, then secure the cord with the DC cord clamp attached to the hole as shown in the figure.

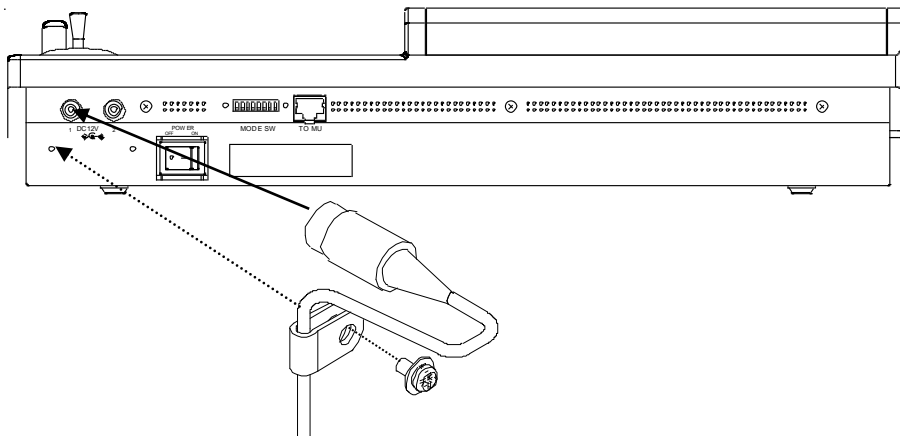

3-1-3. Optional Configuration

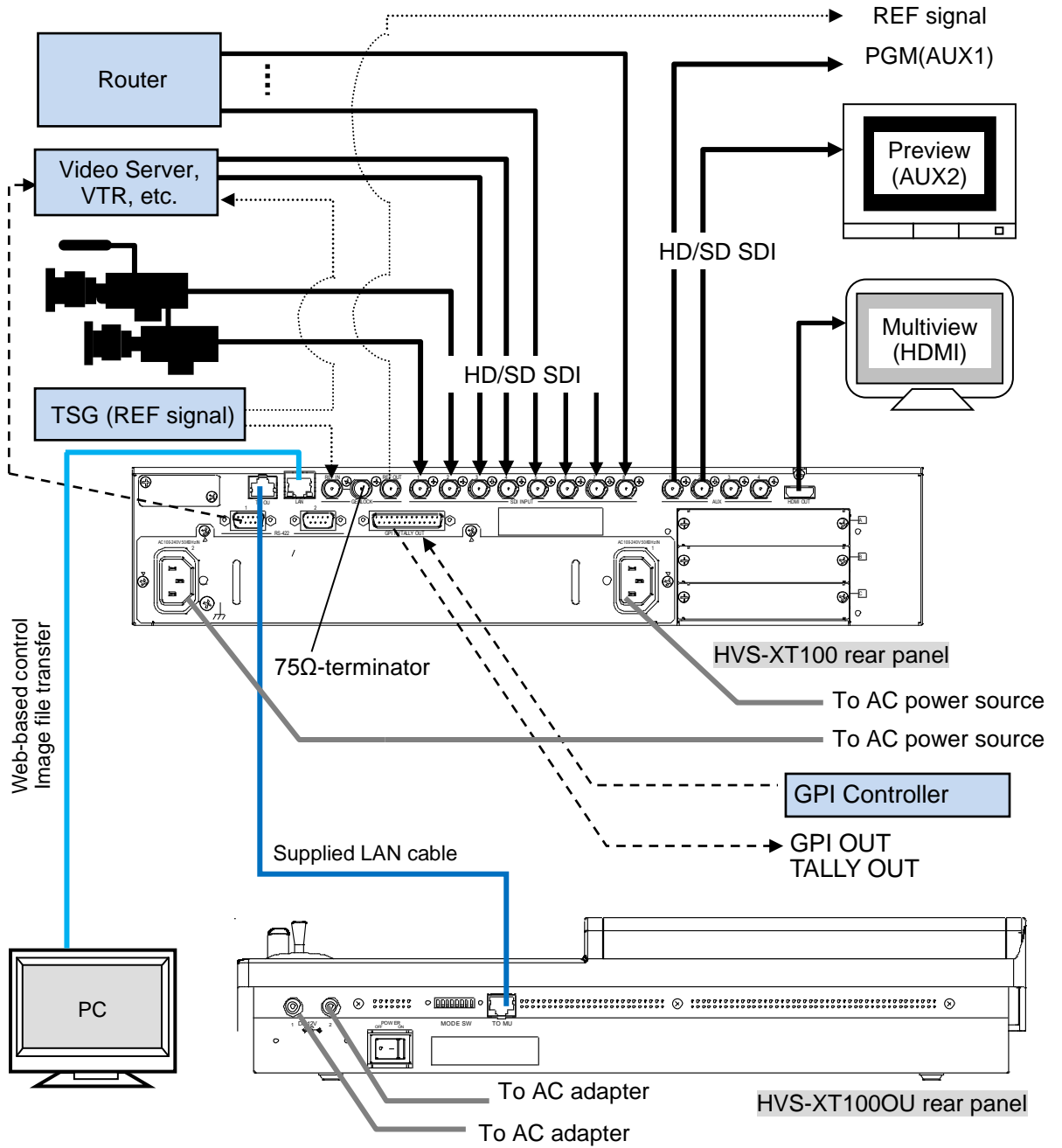

External Device Connections

Device / Signal	Connection / Interface	Refer to sec.
Multiviewer output	SDI (BNC) or HDMI	13
GPI in/out, Tally out	GPI IN/TALLY OUT	20-1
Tally unit	RS-422	20-1-3
VTR	RS-422	20-2
Router	RS-422	20-3
Editor	RS-422 (with software option)	20-4
AUX bus control boxes (HVS-AUX8/16/32)	ARCNET LAN (optional)	20-5
Remote Panel (HVS-30RU)	RS-422	20-6
PC (Web browser control)	Ethernet	21
PC (Image transport)	Ethernet	12-4

3-2. HVS-XT110

3-2-1. Basic Configuration

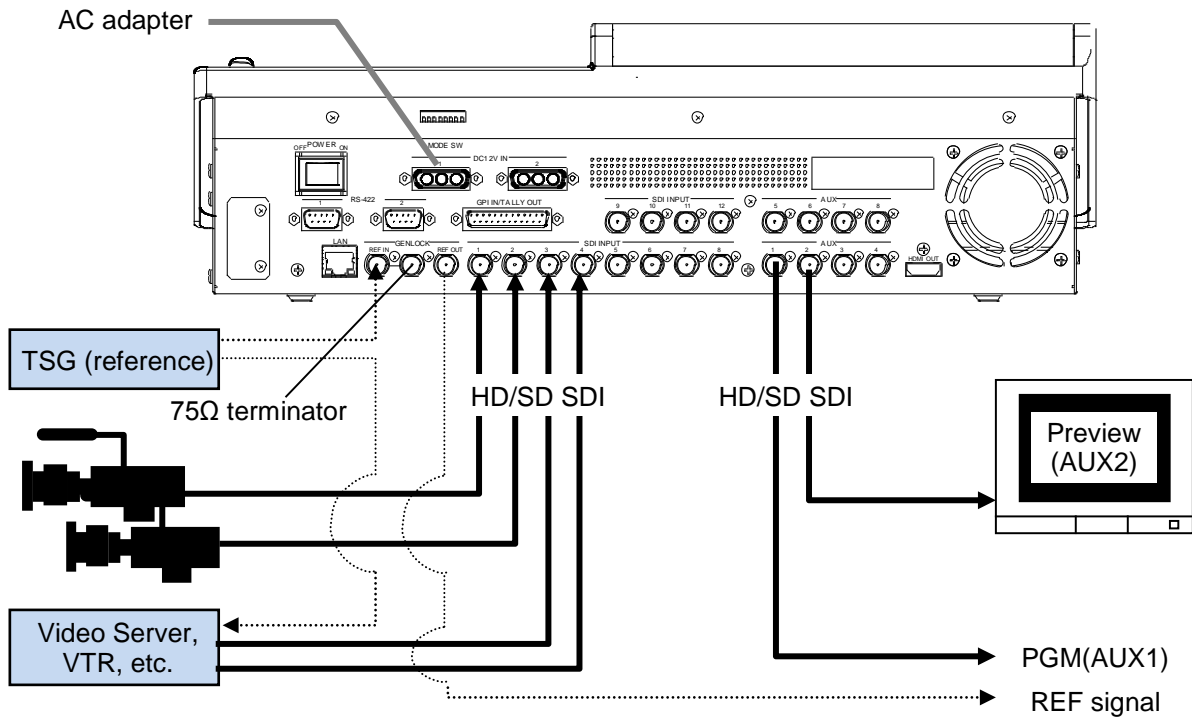

- ▶ See section 18-3. "Selecting a Reference Signal" for details on setting a reference signal.
- ▶ See section 6-2. "Preview Set Up" for details on displaying preview image.

3-2-2. Optional Configuration

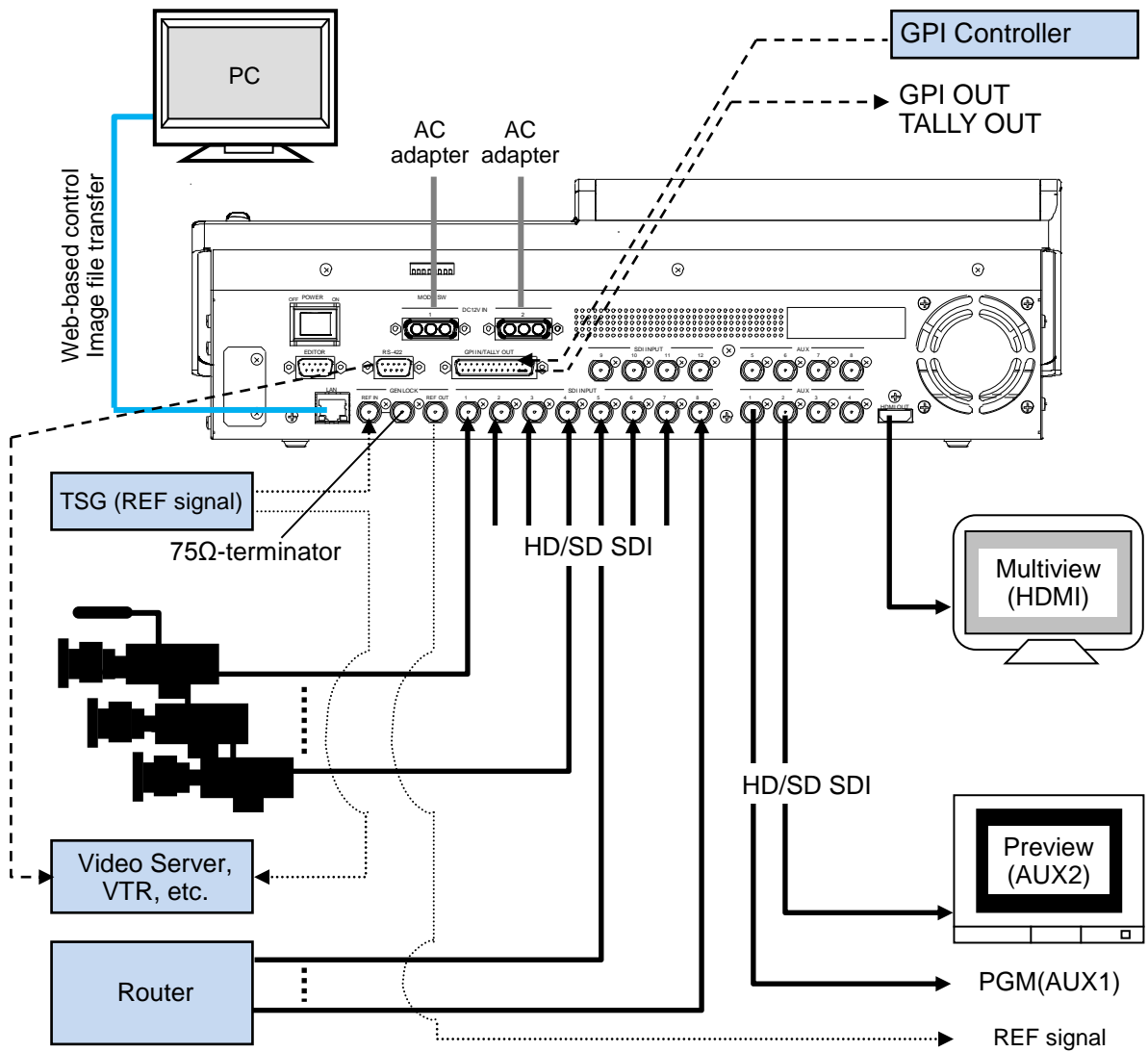

External Device Connections

Device / Signal	Connection / Interface	Refer to sec.
Multiviewer output	SDI (BNC) or HDMI	13
GPI in/out, Tally out	GPI IN/TALLY OUT	20-1
Tally unit	RS-422	20-1-3
VTR	RS-422	20-2
Router	RS-422	20-3
Editor	RS-422 (with software option)	20-4
AUX bus control boxes (HVS-AUX8/16/32)	ARCNET LAN (optional)	20-5
Remote Panel (HVS-30RU)	RS-422	20-6
PC (Web browser control)	Ethernet	21
PC (Image transport)	Ethernet	12-4

3-3. Power ON

Before powering on the system, verify that all system connections have been properly made according to the previous sections.

3-3-1. HVS-XT100/XT100OU

- (1) Use the supplied LAN cable with the HVS-XT100OU to connect the **TO OU** connector on the HVS-XT100 rear panel and the **TO MU** connector on the HVS-XT100OU rear panel.
- (2) Use the supplied power cord to supply AC power to the HVS-XT100. Secure the power cord with the attached cord clamp.
 - ▶ See section 3-1-2. "Installing the Power Cord Retaining Clamp."
- (3) Use the supplied AC adapter and power cord to supply power to the HVS-XT100OU. Secure the DC cord to the HVS-XT100OU rear panel with the supplied cord clamp.
 - ▶ See section 3-1-2. "Installing the Power Cord Retaining Clamp."
- (4) Turn on the power switches on the HVS-XT100 front panel and HVS-XT100OU rear panel.

IMPORTANT

Do not plug in or out of AC adapters or power cords while the switcher is powered on.
--

3-3-2. HVS-XT110

- (1) Connect the AC adapter to the switcher.
- (2) Supply AC power to the AC adapter using the supplied power cord.
- (3) Turn on the power switch located on the rear panel of the switcher.
 - If redundant power is supplied using the HVS-XT110PSM, the power switch will turn on both power supply units.

IMPORTANT

Do not plug in or out of AC adapters or power cords while the switcher is powered on. Supply AC power after the AC adapter is connected to the switcher. Otherwise the switcher internal parts may be damaged.
--

3-4. System Signal Format Selection at Initial Use

When first switching your unit on, select a signal format as shown below.

- (1) The **MENU** button in the SELECT/KEYPAD block at the right of the menu display should blink when powered ON.
- (2) Press **MENU**, then press **SETUP**.
- (3) The SETUP menu top page appears in the menu display. Turn **F1** to select **SYSTEM** and then press **F1**.

SETUP	:	> SYSTEM	>INPUT	>OUTPUT	>PANEL
MENU	:	>GPI/TLY	>FUNCTION	>EXT I/F	>STATUS

- (4) The [SETUP - SYSTEM] menu as shown below appears. Turn **F1** to select **FORMAT** and then press **F1**.

SETUP	:	> FORMAT	>REF I/O	>ARCNET	>ETHERNET
SYSTEM	:	>RS-422	>TIME	>INIT	>REBOOT

- (5) The [SETUP - SYSTEM - FORMAT] menu as shown below appears.
Turn **F1** to select the signal format used in the switcher, then press **F1**.
- (6) Turn **F3** to select the aspect ratio, then press **F3**.
For example, to use HD-SDI signals (1080i, 59.94Hz), set as shown below.

SYSTEM	:	FORMAT	:	ASPECT	:	SW TMNG:	1/1
FORMAT	:	= 1080/59.94i	:	= 16:9	:	=ODD	:

- (7) Press the page up button to return to the [SETUP - SYSTEM] menu.
- (8) Turn **F1** to select **REBOOT** and press **F1**.
- (9) Press **ENTER** in the SELECT/KEYPAD block to reboot the switcher

SETUP	:	>FORMAT	>REF I/O	>ARCNET	>ETHERNET
SYSTEM	:	>RS-422	>TIME	>INIT	> REBOOT

After restarting the switcher, the selected format and aspect are applied.

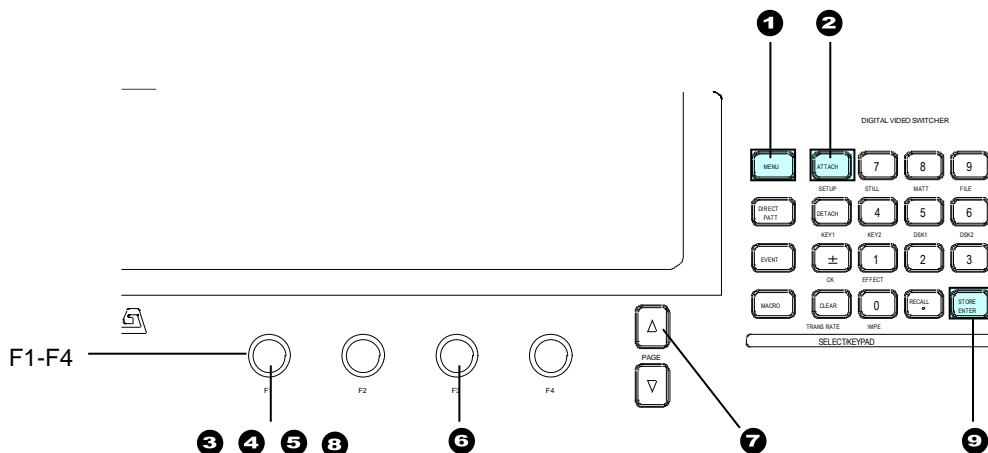

3-5. Setting Date, Time and Time Zone at Initial Use

When first switching your unit on, set the date, time and time zone as shown below.

- (1) Press **MENU** in the SELECT/KEYPAD block, then press **SETUP** to display the SETUP top menu. Turn **F1** to select **SYSTEM**, then press **F1** or the page down button to open the [SETUP - SYSTEM] menu.
- (2) Turn **F1** to select **TIME**, then press **F1** or the page down button to open the [SETUP - SYSTEM - TIME] menu.

SETUP	:	>FORMAT	>REF I/O	>ARCNET	>ETHERNET
SYSTEM	:	>RS-422	> TIME	>INIT	>REBOOT

- (3) If you need to change the date, press **F1** to select Month, Day or Year, then turn **F1** to change the setting.
- (4) If you need to change the time, press **F3** to select Hour, Minute or Second, then turn **F3** to change the setting.

SYSTEM	:	DATE(mm/dd/yy)	:	TIME[10:20:10]	:	1/4
TIME	:	=SEP/01/13	:	=10:20:20	:	

- (5) Press the page down button to open PAGE 2.
- (6) Turn **F3** to set the time zone offset value.

SYSTEM	:	1st	CHK:SUMMER	:	TIME ZONE	:	2/4
TIME	:	=OFF	:	=OFF	:	=UTC[9:00]	:

IMPORTANT
The date and time information are used for the multiviewer clock and when backing up image or setting files. Note that date and time information may be lost if the switcher is powered OFF for more than 100 hours (or less if it is not fully charged). In such case, reset the date and time.

4. Menu Operation

4-1. How to Access Menus

4-1-1. Menu Access Buttons

Press **MENU** on the left side of the SELECT/KEYPAD block, then press the buttons on the keypad to access menus.

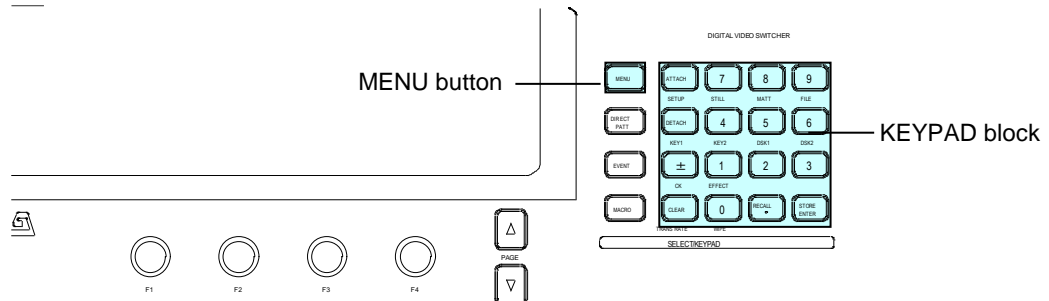

◆ KEYPAD Block

Button	Accessed menu	Menu Description
SETUP	SETUP MENU	Accesses menu for the setups of system, panel, video input, video output and external interface settings.
STILL	STILL STORE	Accesses menu for operations with involving still images and video clips.
MATT	MATT COLOR	Accesses menu for matte color.
FILE	FILE TOP	Accesses menu for file operations using a USB.
KEY1	KEY1 SETUP	Accesses menu for KEY1 settings.
KEY2	KEY2 SETUP	Accesses menu for KEY2 settings.
DSK1	DSK1 SETUP	Accesses menu for DSK1 settings.
DSK2	DSK2 SETUP	Accesses menu for DSK2 settings.
CK	CHR KEY SETUP	Accesses menu for chromakey settings.
EFFECT	EFFECT SETUP	Accesses menu for sub effect channel settings.
TRANS RATE	TRANS RATE	Accesses menu for transition settings.
WIPE	WIPE	Accesses menu for WIPE pattern modification.

◆ SELECT / keypad Block

Four modes buttons on the left side of the SELECT/KEYPAD block change the keypad mode as shown in the table below.

Mode Button	Function
MENU	Changes the keypad to menu access buttons. Pressing a button in the keypad displays the associated menu. The MENU control button blinks if a parameter has changed and requires rebooting. In such case, reboot the switcher. ▶ See section 19-1. "Rebooting System."
DIRECT PATT	Changes the keypad to direct pattern selection buttons.
EVENT	Changes the keypad to event memory buttons.
MACRO	Changes the keypad to macro control and memory buttons

4-1-2. Other Menu Access Buttons

Aside from the menu buttons, the related menu pages can be displayed by **pressing** (buttons in **C**) or **Double-pressing (quickly pressing twice)** (buttons in **A** and **B**) specific buttons as shown in the tables below.

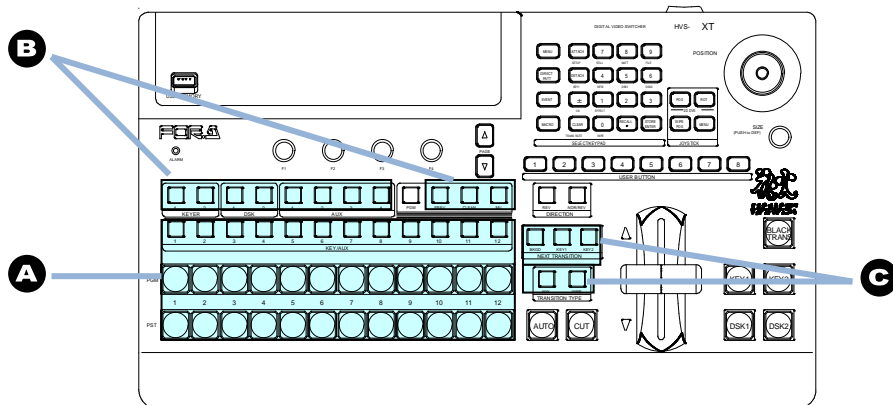

PGM/PST and KEY/AUX blocks

See Fig.	Button	Accessed Menu (Page)
A	MATT1-2	[MATT] menu
	STL1-2	[STILL] menu
	STK1-2	[STILL] menu
	CKFIL	[CHR KEY - SETUP] menu
	CKKEY	[CHR KEY - SETUP] menu
	CB	[SETUP - INPUT - COLRBAR] menu
	EFF1-2	[EFFECT(1, 2)] menu
	SHIFT	[SETUP-INPUT-ASSIGN](3/3) menu

Note that the buttons in this table represent the bus buttons assigned to MATT1, MATT2, STILL1, STILL2, and other signals respectively on the PGM/PST and KEY/AUX bus blocks. (Refer to section 5. "Video Sources.")

BUS SELECT and KEY/AUX blocks

See Fig.	Button	Accessed Menu (Page)
B	KEY1, KEY2	[KEY (1, 2)- SETUP] menu
	DSK1, DSK2	[DSK (1, 2)- SETUP] menu
	AUX1 to AUX4	[SETUP - OUTPUT - OUT XPT](1/3) menu
	PREV	[SET UP - OUTPUT - CLN/PREV] PREV menu
	CLEAN	[SET UP - OUTPUT - CLN/PREV] CLEAN menu
	MV	[SETUP - OUTPUT - MV] menu

Transition block

See Fig.	Button	Accessed Menu (Page)
C	BKGD	[TRANS](1/6) menu
	KEY1	[TRANS](2/6) menu
	KEY2	[TRANS](3/6) menu
	MIX	[TRANS](1/6) menu
	WIPE	[TRANS](1/6) menu

4-1-3. USER Buttons (Menu Shortcut)

User buttons can be assigned to specific menu pages and used as menu shortcuts.

► See section 14. "USER Buttons" for details.

4-2. How to Set Values

4-2-1. Displaying Parameters

See section 4-1. "How to Access Menus" to display a desired menu. If a menu has multiple submenus such as the SETUP menu, navigate to submenus following the procedure below.

◆ Menu Navigation (Example for the SETUP menu)

- (1) Press **MENU** in the SELECT/KEYPAD block, then **SETUP** to display the SETUP menu. The SETUP menu top page will then appear on the display, as shown below.

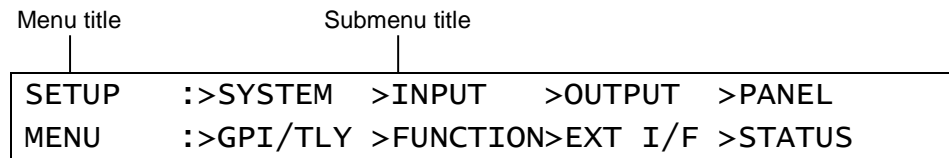

- (2) Select a submenu to open by turning **F1** (The INPUT submenu is selected in the example below.) Then press **F1** or the page down button to the right to open the selected submenu.

The current selection is shown in reverse video.

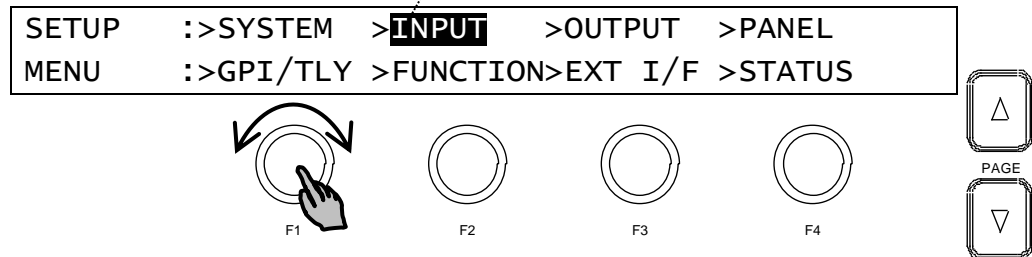

- (3) The [SETUP - INPUT] menu then opens. The [SETUP - INPUT] menu also has submenus. Select a submenu by turning **F1** and then press **F1** or the page down button to open the submenu. A ">" in front of menu items indicates that a detail submenu can be accessed by pressing **F1**.





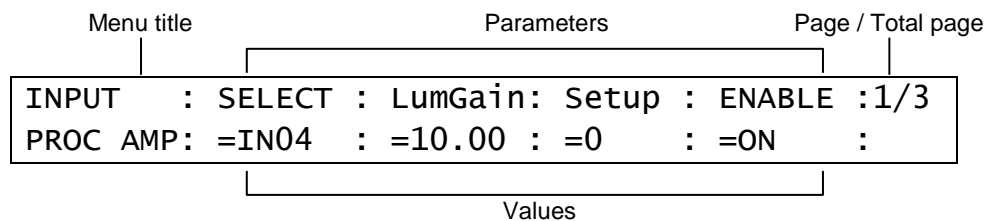





- (4) The [SETUP - INPUT - PROC AMP] menu is displayed as shown below. Now users can change the parameter values.



◆ Page Navigation

As shown in the example below, the [SETUP - INPUT - PROC AMP] submenu spreads across three pages. When first accessed, page 1 of 3 will be displayed. To go to page 2, simply press the page down button. Pressing the page up button returns you to page 1. Pressing the page up button when located on the first page brings you up one level in the menus. The same happens when pressing the page down button when located on the last page of a menu.

Page no. / Total page

INPUT :SELECT :LumGain: Setup :ENABLE : 1/3 PROC AMP: =IN04 : =10.00: =0 : =ON :	 <small>PAGE</small> 
INPUT :SELECT :ChmGain: Hue :ENABLE : 2/3 PROC AMP: =IN04 : =10.00: =0 : =ON :	 <small>PAGE</small> 
INPUT :WHT-Lv :BLK-Lv :Chroma : : 3/3 CLIP : =1019 : =-70 : =1110 : :	 <small>PAGE</small> 
SETUP :>SIGNAL >PROC AMP>RENAME >ASSIGN INPUT :>COLORBAR	 <small>PAGE</small> 

4-2-2. Changing Settings or Values Using F1 to F4

Once parameters appear in the display window, data is displayed over 2 lines. A maximum of four parameters can be displayed at a time. An "=" or ">" in front of a value indicates that it is possible to change a parameter setting by turning a menu control push-button (F1 - F4), or trigger an action by pressing it.



Title	Parameters (First line) Settings (Second line)	Page/Total page
INPUT	:SELECT :FORMAT :RESIZE : FS	: 1/4
SIGNAL	: =IN01 : =AUTO : =--- : =ON	:

F1

F2

F3

F4

PAGE

Menu Control Push-buttons (F1 to F4)	Description
Turn clockwise	Increases value.
Turn counter-clockwise	Decreases value.
Press and hold down at least 1 sec.	Resets the parameter to its default value.
Turn while pressing	Quickly increases/decreases value.

◆ System Parameters Requiring Confirmation

For some system parameters, you will have to press menu control push-buttons after changing parameter settings by turning menu control push-buttons. This prevents users from making mistakes when important system settings are changed.

◆ **Parameters with the sign ">"**

Parameters with ">" sign in front of them are executable by pushing the relevant menu control push-button. For example, pressing a menu control push-button initializes menus, stores/recalls still images, clips or setting files.

- ▶ See section 4-3. "How to Return Settings to Default."
- ▶ See section 12. "Still and Clip Store."
- ▶ See section 17. "File Operation."

The relevant menu control push-button should be pressed to apply a preset color.

- ▶ See section 5-9. "Bus Matte")

4-2-3. Changing Settings or Values Using the Numeric Keypad

Users can also use the keypad to input numerical settings to a menu. A procedure example for changing the matte color by using the keypad is as follows.

- (1) Press **MENU** in the SELECT/KEYPAD block.
- (2) Press **MATT** to display the [MATT COLOR] menu.
- (3) To change the S (Saturation) item, press **F1**.
- (4) Input a new setting from the keypad.
- (5) Press **ENTER** to confirm the setting.
- (6) To change the L (Luminance) setting, press **F2**, input the new setting from the keypad, then press **ENTER**.
- (7) To change the H (Hue) setting, press **F3**, input the new setting from the keypad, then press **ENTER**.

MATT1 : BUS MATT1 COLOR :RECALL : 1/4
 COLOR :S=50.0 L=80.2 H=125.5: >GREEN:

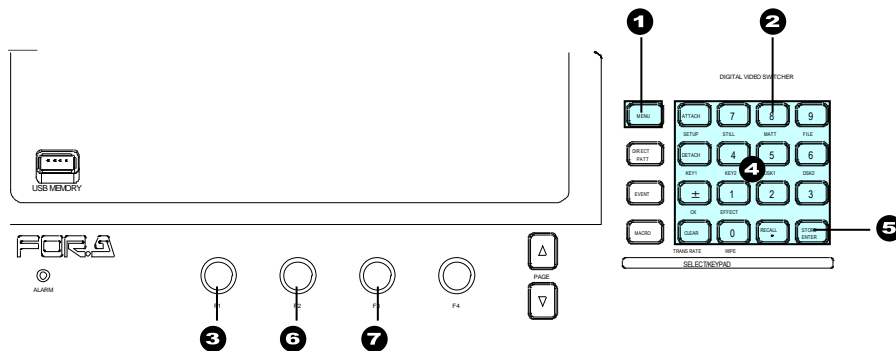

IMPORTANT

When pressing a push-button, press down lightly and release it within 1 sec. Note that if you press and hold a control button for more than 1 sec., the associated settings will return to their default value and a beep will sound.

- Pressing **CLEAR** cancels the changes just made.
- To enter a negative number, enter the number, press **±** then press **ENTER**.

KEYPAD Operation in Numeric Input mode

The keypad can operate in multiple modes such as Menu, Direct Pattern, Macro and Event using the mode buttons on the left side of the keypad. To input menu settings using the keypad, display a desired parameter, press the menu control push-button located just below the parameter in the menu display (**F1**-**F4**), enter the value using the numeric keypad, then press **ENTER** on the KEYPAD.

4-2-4. Changing Settings or Values Using the Joystick

Users can also use the joystick to set position, size and color settings to specific parameters. Menu pages controllable from the JOYSTICK block are shown in the table below.

◆ Controllable Parameters

Menu	Parameter			
	Menu item	X-axis	Y-axis	SIZE
MATT1	BUS MATT1 COLOR	SAT	LUM	HUE
MATT2	BUS MATT2 COLOR1-2	SAT	LUM	HUE
KEY1, KEY2 DSK1, DSK2	BORDER COLOR	SAT	LUM	HUE
	POSITION SIZE (*1)	X	Y	SIZE
	LOCAL ROTATION (*1)	X	Y	Z
	CENTER POSITION (*1)	X	Y	Z
KEY1, KEY2	KEY EDGE COLOR	SAT	LUM	HUE
WIPE (0 to 99)	BORDER COLOR	SAT	LUM	HUE
	POSITION ANGLE (*2)	POS-X	POS-Y	ANGLE
WIPE (100 to 137)	BORDER COLOR	SAT	LUM	HUE
	POSITION SIZE (*2)	POS-X	POS-Y	SIZE
CHR KEY	AUTO CK	POS-X	POS-Y	SELECT

(*1) To open the associated menu, Double-press **POS** or **ROT** in the Joystick section.
 ► See section 9-8. "DVE Effects on KEY/DSK."

(*2) Pressing **WIPE POS** on the Joystick block allows you to control parameters via the joystick without opening the menu.

How to Use the Joystick

Users can simultaneously perform up to three item settings using the joystick as below.

- (1) Open a menu page you want to set.
- (2) Press **MENU** in the joystick block.
- (3) Move the joystick to the desired direction to change three items simultaneously.
 - X-axis Moves the joystick left and right (for S item above).
 - Y-axis Moves the joystick up and down (for L item above).
 - Z-axis Turn **SIZE** clockwise or counterclockwise (for H item above).

```
WIPE      :      BORDER COLOR      :RECALL : 2/2
BORDER    :S=66.3  L=5.4   H=3.5   : >BLUE :
```

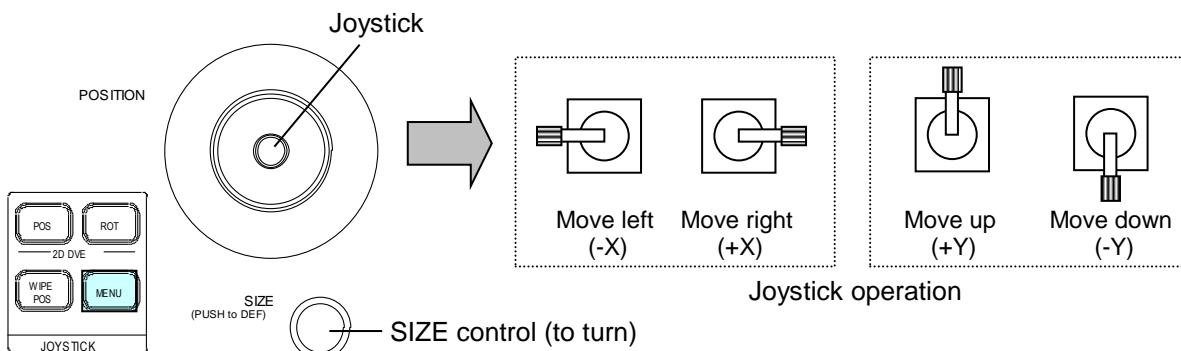

FINE Control (using a user button)

Assign "JOYSTICK -FINE ENABLE" to a user button, then press the button. The button will turn on to allow the user to have finecontrol over the joystick.

► See section 14. "USER Buttons."

4-3. How to Return Settings to Default

4-3-1. Returning Parameters to Default

Pressing and holding down Control Push-buttons

Press and hold the control push-button (**F1** - **F4**) below each parameter to return the resoective settings to their factory default.

Briefly pressing the DEF button

If you need to reset parameters that can be set by the joystick, display parameters and press the **SIZE** control (PUSH TO DEF). The selected parameters will simultaneously reset to factory default.

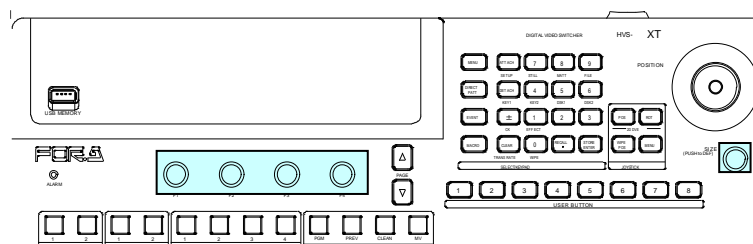

4-3-2. Returning Menus to Default

Using INIT parameters

Some menus have an INIT parameter in the menu top page. Selecting **INIT** and pressing the control push-button returns all parameters in the menu to their default settings. Turn the associated push-button to select **ALL** or a category you want to return to default if INIT can be set, then press the push-button to reset the parameters.

Menu where INIT included	Menus to be returned to default settings
[SETUP - SYSTEM] menu	See section 19-2. "System Initialization."
[WIPE - MODIFY] menu	Each submenu in the [WIPE MODIFY] menu.
[KEY - SETUP] menu	Each submenu in a [KEY - SETUP] menu.
[CHR KEY - SETUP] menu	The [CHR KEY - SETUP] menu
[EFFECT - SETUP] menu	Each submenu in an [EFFECT - SETUP] menu

4-4. How to Back up Settings

One of the following three operations allows users to back up and load panel settings automatically at startup. Any of the three operations is recommended after changing menu settings.

- Rebooting (Be sure to reboot the switcher instead of turning the power off then on.)
 - ▶ See section 19-1. "Rebooting System."
- Moving to the top page in the SETUP menu.
- Saving / loading an event.

Background and key settings can be automatically loaded to the panel at startup.

- ▶ See section 15-6. "Loading an Event at Start-up" for details.

5. Video Sources

5-1. How to Assign User Names to Sources

Video inputs, Still1-2, StillKey1-2, Matte, Black and Color bar can be assigned user-specific names, to make them easier to identify for operators. User names can be given to input signals, internally generated black mattes and matte signals, and still pictures. Follow the procedure below to name a signal source.

- (1) Press **MENU** in the SELECT/KEYPAD block, then press **SETUP** to display the SETUP menu top page.
- (2) Turn **F1** to select **INPUT**. Then press **F1** or the page down button to display the [SETUP - INPUT] menu.
- (3) Turn **F1** to select **RENAME**. Press **F1** or the page down button to display the [SETUP - INPUT - RENAME] menu.

SETUP :>SIGNAL >PROC AMP> RENAME >ASSIGN INPUT :>COLORBAR

- (4) Turn **F1** to select a signal under **SELECT**. (See the table below.)

INPUT :SELECT :SHORT : LONG NAME(MV) : 1/1 RENAME : =IN04 : =IN04 : =INPUT04 :
--

SELECT	SHORT default setting	LONG NAME default setting ^(*)	Signal description
BLACK	BLK	BLACK	Black signal
XT100	IN01 to IN08	INPUT01 to INPUT08	SDI video input to rear connectors 1-8
	INA1 to INA4 INB1 to INB2	INPUT09 to INPUT14	SDI video input to Slots A and B (See section 2-2-1. "Option Slots".)
XT110	IN01 to IN12	INPUT01 to INPUT12	SDI video input to rear connectors 1-12
STILL1, STILL2	STL1, STL 2	STILL1, STILL2	Still images 1-2
STILK1, STILK2	STK1, STK2	STILLKEY1, STILLKEY2	Still KEYOUT (alpha channel) images1 -2
CKFIL	CKFL	CK FILL	Chromakey fill signal
CKKEY	CKKY	CK KEY	Chromakey key signal
MATT1, MATT2	MAT1, MAT2	MATTE1, MATTE2	BUS matte color 1 and 2
SBEF1, SBEF2	EFF1, EFF2	SUB EFF1, SUB EFF2	Sub effect channels
CLBAR	CLBR	COLOR BAR	Color bar

(*) Long names are used for titles displayed on the multiviewer screen.

- (5) To change the short name of a signal, use **F2** to assign a name up to 4 characters in length, entering the characters one by one. First, press **F2** to highlight a character. When the latter is highlighted, turn **F2** to change it. Alphanumeric characters and symbols (ASCII characters) can be used for names.
- (6) To change the long name of a signal, use **F3** to assign a name up to 8 characters in length, entering the characters one by one. First, press **F3** to highlight a character. When the latter is highlighted, turn **F3** to change it. Alphanumeric characters and symbols (ASCII characters) can be used for names.

5-2. How to Assign Sources to Bus Buttons

Primary and optional video inputs, internally generated signals (black, mattes, etc.), and captured stills can be freely assigned to bus buttons using the procedure below. Signal-to-Button mappings are shared on the PGM/PST and KEY/AUX bus.

- (1) Press **MENU**, then **SETUP** to display the SETUP menu top page.
- (2) Turn **F1** to select **INPUT**. Press **F1** or the page down button to display the menu.
- (3) Turn **F1** to select **ASSIGN**. Press **F1** or the page down button to display the [SETUP - INPUT - ASSIGN] (1/3) menu.

INPUT	:BUTTON	: SIGNAL NAME	:INHIBIT:	1/3
OU ASGN	: =01	: =IN04	=IN04	: =OFF :

- (4) Turn **F1** to select a bus button under **BUTTON**.
 - (5) Turn **F2** to select the signal to be assigned under **SIGNAL**. Users can also select a signal by turning **F3** under **NAME**. **SIGNAL** and **NAME** are linked to each other.
- See section 5-1. "How to Assign User Names to Sources" for more details.

Submenu	Parameter	Default	Setting range
OU ASSIGN	BUTTON	1	1-20, sft1-sft20 (shifted buttons)
	SIGNAL NAME	IN01	(See the table below)
	INHIBIT	OFF	OFF, ON

BUTTON	SIGNAL (NAME) setting		Description	Refer to	
01 to 12, sft01 to sft12 (shifted buttons)	NONE	---	No signal assignment		
	BLACK	BLK	Black signal		
	XT 100	IN01-IN08	IN01-IN08	Video input to rear connectors 1-8	6
		INA1-INA4	IN09-IN14	Video input to rear Slot A	
		INB1-INB2		Video input to rear Slot B	
	XT 110	IN01- IN12	IN01- IN12	Video input to rear connectors 1-12	
	STIL1, STIL2	STL1, STL 2	Still images 1 and 2	12-1	
	STILK1, STILK2	STK1, STK2	Still key (alpha channel) images 1 and 2	12-1	
	CKFIL	CKFL	Chromakey fill signal	10	
	CKKEY	CKKY	Chromakey key signal	10	
	SBEF1, SBEF2	EFF1, EFF2	Sub Effect channels		
	MATT1, MATT2	MAT1, MAT2	BUS MATT Color 1 and 2	5-9	
	CLBAR	CLBR	Internally generated color bar signal		
SHIFT	SHIFT	Shift button function	7-3		

To Disable Bus Button Operation

Users can inhibit operation of specific bus buttons. First, set **INHIBIT** to **ON** for a bus button on PAGE 1, and the selected bus button on the PGM/PST is set to INHIBIT. Next, set **INHIBIT** to **ENABLE** on PAGE 3 to enable the bus button inhibit function. Bus buttons, set to INHIBIT cannot select signals. The INHIBIT setting has no effect on the KEY/AUX bus.

INPUT	:BUTTON	: SIGNAL NAME	:INHIBIT:	1/3
OU ASGN	: =01	: =IN04	=IN04	: = ON :

INPUT	:SELECT	: SHIFT	: LINK	:INHIBIT:	3/3
ASSIGN	: =OU	: =NORML:	=---	: = ENABL :	

5-3. Resize Function

A resize function allows users to input **SD signals** at the same frame-rate **as that in HD mode**, and enlarge them to use as **HD images**.

Reisizable Inputs	HVS-XT100	HVS-XT110
	IN05 to IN08 (4 inputs) HVS-XT100DI-A (option card): Ch1, Ch2 (2 inputs) HVS-XT100AI (option card): Ch1, Ch2 (2 inputs)	IN05 to IN08 (4 inputs)

- (1) Display the [SETUP - INPUT] menu.
- (2) Turn **F1** to select **SIGNAL**. Press **F1** or the page down button to display the [SETUP - INPUT - SIGNAL] menu.

```

SETUP  :>SIGNAL >PROC AMP>RENAME >ASSIGN
INPUT  :>COLORBAR
    
```

- (3) Turn **F1** to select an input signal for resizing.
- (4) Turn **F2** to set **AUTO** or **SD-SDI** for **FORMAT**.
- (5) Turn **F3** to select an aspect ratio under **RESIZE**.

```

INPUT  : SELECT : FORMAT : RESIZE : FS      :1/4
SIGNAL : =IN05  : =SD-SDI: =4:3   : =ON    :
    
```

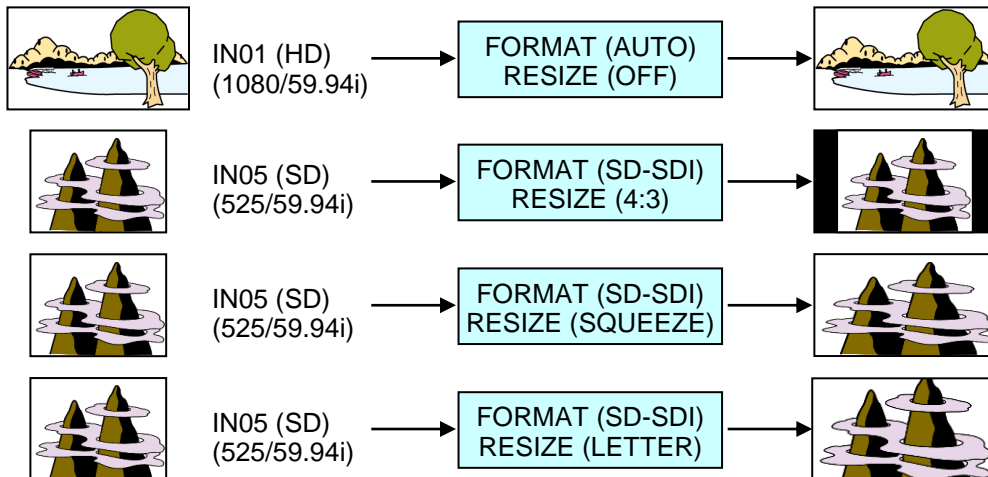

IMPORTANT

The Resize function is automatically enabled when SD signals are input to the switcher in HD mode, and FORMAT in the [SETUP - INPUT - SIGNAL] menu is set to SD-SDI. (Ensure the Resize function stays disabled if HD-SDI is set for FORMAT.)

The side panel color or image can be changed in 4:3 mode.

► See section 5-5 "Changing the Side Panel Image."

5-4. INPUT STILL (Freezing Input Video)

Video inputs (IN01 to IN08) can display frozen images (INPUT STILLS) by capturing video. Still images can also be uploaded using the FILE menu.

▶ See section 12-4-3. "Sending / Receiving Still Images."

Inputs that can use an INPUT STILL.	HVS-XT100	HVS-XT110
	All inputs	IN01 to IN08 (8 inputs)

◆ To Freeze Input Video

- (1) Display [SETUP - INPUT - SIGNAL] menu PAGE 2.
- (2) Select an input under **SELECT**.
- (3) Turn **F2** to select **GRAB**, then press **F2**. The input video will be displayed frozen.
- (4) Turn **F3** to select a freeze type from **ODD**, **EVEN** and **FRAME**.

INPUT	: SELECT	: CONTROL	: FREEZE	:	:	2/4
STILL	: = IN01	: > GRAB	: = FRAME	:	:	

◆ Returning to the Input Video Display

To display the input video again from the frozen image, turn **F2** to select **CLEAR**, then press **F2**.

◆ To Freeze Input Video Using a User Button (Operation Example)

<Assigning **INPUT STILL STORE** to **USER 1**>

- (1) Press **MENU** then **SETUP** in the SELECT/KEYPAD block to open the [SETUP] top menu.
- (2) Turn **F1** to select **PANEL**, then press **F1** or the page down button to display the submenu.
- (3) Turn **F1** to select **USER BTN**, then press **F1** or the page down button to display the [SETUP-PANEL - USER BUTTON](1/2) menu.
- (4) Turn **F1** to select **OU-1** (OU USER 1). **USER 1** will blink.
- (5) Turn **F2** to select **STILL**. Turn **F3** to select **INPUT STILL STORE**.

USER	: SELECT	: TYPE	: FUNC(F3)	:	:	1/2
BUTTON	: = OU-1	: = STILL	: = INPUT STILL STORE	:	:	

<Freezing IN01>

- (1) Holding down **USER 1**, press the KEY/AUX bus button to which IN01 is assigned. (For example, press **1**, if IN01 is assigned to Bus Button 1.)
- (2) A still image for IN01 is automatically captured and saved to memory. Then the KEY/AUX bus button will turn on and the IN01 output video will freeze (replaced with the captured still image.)

<Restoring the IN01 Input Video>

Holding down **USER 1**, press the KEY/AUX bus button to which IN01 is assigned. The frozen image for IN01 is cleared and the IN01 input video is restored and displayed on an output screen.

IMPORTANT

INPUT STILLS use the frame synchronizer buffer memory. Therefore, the frame synchronizer will be inoperable while an INPUT STILL image is being displayed or enabled.

▶ See section 5-7. "Frame Synchronizer."

5-5. Changing the Side Panel Image

The side panel image of 4:3 video can be changed as shown in the procedure below.

- (1) Display the [SETUP - INPUT] menu.
- (2) Turn **F1** to select **SIGNAL**. Press **F1** or the page down button to display the [SETUP - INPUT - SIGNAL] menu.
- (3) To change the side bar color for 4:3 images, press the page down button to go to PAGE3.
- (4) Turn **F1** to select an input signal to which side panels are to be added.
- (5) Turn **F2** to set the side panel to **ON**.
- (6) Turn **F3** to select an input signal to be used for the side panel. Options are **BLACK**, **INPUT01-12**, **STILL1-2**, and **SDMT**. Select **SDMT** (single color for side panel) for the signal in this example.

```
INPUT   : SELECT :   SIDE PANEL   :XPT DLY: 3/4
SIDE PNL: =IN01  :En=ON   S=SDMT   : =0      :
```

- (7) Press the page down button to go to PAGE 4 to set the SDMT color.
- (8) Turn **F4** to select a color from the following 8 standard colors. Then press **F4** to apply the setting. If you want to adjust the selected color or set the color by entering its HSL values.
 - ▶ See section 5-9. "Bus Matte" for details on how to set colors.

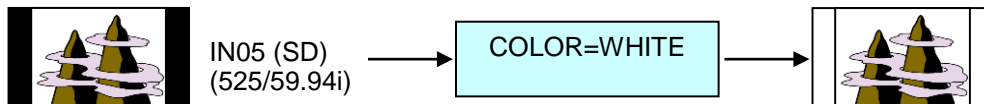

5-6. XPT DELAY

The XPT DELAY (crosspoint delay) feature allows you to add a time delay until a signal is changed after pressing a bus button. To enable the feature, proceed as follows:

- (1) Display the [SETUP - INPUT] menu.
- (2) Turn **F1** to select **SIGNAL**. Press **F1** or the page down button to display the [SETUP - INPUT - SIGNAL] menu.
- (3) Press the page down button to go to PAGE 3.

```
INPUT   :SELECT :   SIDE PANEL   :XPT DLY: 3/4
SIDE PNL: =IN01  :En=ON   S=SDMT   : =30   :
```

- (4) Turn **F1** to select an input signal. Select **IN01** in this example.
- (5) Turn **F4** to set a delay value in frames.
- (6) Press **IN01** (the bus button to which **IN01** is assigned) on the PGM bus. The PGM image is switched to the **IN01** image 30 frames after the bus button is pressed.

5-7. Frame Synchronizer

Users can select whether to apply frame synchronization to input signals or not (for each signal) as shown in the procedure below.

Inputs that can use the FS function.	HVS-XT100	HVS-XT110
	All inputs	IN01 to IN08 (8 inputs)

- (1) Display the [SETUP - INPUT - SIGNAL] menu.
- (2) Turn **F1** to select an input signal for use.
- (3) Turn **F4** to set **FS** to **ON** and activate the frame synchronizer.

INPUT	: SELECT	: FORMAT	: RESIZE	: FS	: 1/4
SIGNAL	: =IN02	: =AUTO	: =16:9	: = ON	:

◆ To Enable/Disable FS Using a User Button (Operation Example)

<Assigning **FS ENABLE** to **USER 3**>

- (1) Open the [SETUP - PANEL - USER BUTTON] (1/2) menu.
- (2) Turn **F1** to select **OU-3** (OU USER 3). **USER 3** will blink.
- (3) Turn **F2** to select **OTHER**. Turn **F3** to select **FS ENABLE**.

USER	: SELECT	: TYPE	: FUNC(F3)	: 1/2
BUTTON	: = OU-3	: = OTHER :	= FS ENABLE	

<Enabling FS for IN01>

While holding down **USER 3**, press a KEY/AUX bus button to which IN01 is assigned. (Press **1**, for example, if IN01 is assigned to Bus Button 1.) The frame synchronizer function for IN01 will be enabled.

<Disabling FS for IN01>

While holding down **USER 3**, press a KEY/AUX bus button to which IN01 is assigned. The frame synchronizer function for IN01 will be disabled.

Ancillary data in input video cannot be passed through if **FS** (input frame synchronizer) is set to **ON** or **RESIZE** is enabled. To pass ancillary data, input the video synchronized with the genlock signal and set **FS** to **OFF**. Note that ancillary data in SD inputs cannot be used when the switcher operates in HD mode.

5-8. Adjusting Video Signal Levels

5-8-1. Proc Amp

The switcher provides the following Proc Amp features.

- (1) Press **MENU** in the SELECT/KEYPAD block, then press **SETUP** to display the SETUP top menu. Turn **F1** to select **INPUT**, then press **F1** or the page down button to open the [SETUP - INPUT] menu.
- (2) Turn **F1** to select **PROC AMP**, then press **F1** or the page down button to open the [SETUP - INPUT - PROC AMP] menu.
- (3) Turn **F1** to select the input to be adjusted.
- (4) Turn **F4** to set **ENABLE** to **ON** to enable the PROC AMP feature.
- (5) You can adjust the luminance level under **LumGain** and the black level under **Setup**.

INPUT	:SELECT	:LumGain:	Setup	:ENABLE	: 1/3
PROC AMP:	=IN04	: =1.00	: =0	: =ON	:

- (6) Press the page down button to go to PAGE 2.
- (7) You can adjust the chrominance level under **ChmGain** and the color under **Hue**.

INPUT	:SELECT	:ChmGain:	Hue	:ENABLE	: 2/3
PROC AMP:	=IN04	: =10.00:	=0.0	: =ON	:

5-8-2. Video Level Clip

To maintain the desired signal level after adjusting video levels with the Proc Amp, use the Video Level Clip function to adjust the upper and lower limits of YPbPr color space. Note that Video Level Clip can be applied only when the Proc Amp is enabled.

- (1) Open the [SETUP - INPUT - PROC AMP] menu.
▶ See section 5-8-1. "Proc Amp."
- (2) Turn **F1** to select an input signal to be corrected.

INPUT	:SELECT	:LumGain:	Setup	:ENABLE	: 1/3
PROC AMP:	= IN04	: =1.00	: =0	: =ON	:

- (3) Press the page down button twice to go to PAGE 3.
- (4) You can limit signal level settings under **WHT-Lv**, **BLK-Lv** and **Chroma** respectively.

INPUT	:WHT-Lv	:BLK-Lv	:Chroma	:	: 3/3
CLIP	: =1019	: =4	: =1100	:	:

5-9. Bus Matte

Matte signals can be assigned to any bus buttons for PGM, PST and KEY/AUX. (Default assignment: MAT1 to Button 12). Bus matte colors can be specified in the [MATT COLOR] menu.

5-9-1. Setting the Matte Color

- (1) Press **MENU** then press **MATT** in the SELECT/KEYPAD block to display the MATT menu.

```
MATT1 : BUS MATT1 COLOR :RECALL : 1/4
COLOR :S=50.0 L=80.2 H=125.5: >GREEN:
```

- (2) Turn **F4** to select a color from the following 8 standard colors. Then press **F4** to apply the setting.

WHITE, YELLOW, CYAN, GREEN, MAGENTA, RED, BLUE and BLACK

If you want to adjust the selected color or set the color by entering its HSL values, turn **F1**, **F2** and **F3** to enter these values or press **F1**, **F2** and **F3**, enter a value from the keypad then press **ENTER** (from the keypad). Users can also set these three parameters via the JOYSTICK block.

► See section 4-2-4. "Changing Settings or Values Using the Joystick."

Parameter	Setting Range	Description	Joystick operation
S(Saturation)	0.0 to 100.0	Adjusts color saturation.	Moves Joystick horizontally (X -axis)
L (Luminance)	0.0 to 100.0	Adjusts color luminance.	Moves Joystick vertically (Y -axis)
H (Hue)	0.0 to 359.5	Adjusts color hue.	Turn SIZE cw or ccw. (Z -axis)

5-9-2. Setting the Gradient Matte

- (1) Display [BUS MATT 2 COLOR] menu PAGE 2.
 (2) To select a start color for the gradient matte, turn **F4** to select a color or enter the HSL values to specify the color.

```
MATT2 : BUS MATT2 COLOR1 :RECALL : 2/4
COLOR1 :S=50.0 L=80.2 H=125.5: >GREEN:
```

- (3) Press the page down button to go to [MATT COLOR] menu PAGE 3.
 (4) To select an end color for the gradient matte, turn **F4** to select a color or enter the HSL values to specify the color.

```
MATT2 : BUS MATT2 COLOR2 :RECALL : 3/4
COLOR2 :S=50.0 L=80.2 H=125.5: >GREEN:
```

- (5) Press the page down button to go to [MATT COLOR] menu PAGE 4.
 (6) Turn **F1** to select a pattern for the gradation matte. Set the position at **POS** and border softness at **SOFT**.

MATT2	: PATTERN		: POS	: SOFT	: 4/4
GMAT	: =H		: =0	: =0	:

PATTERN setting	Description
COLOR1	Displays the matte color set at BUS MATT2 COLOR1.
H	Displays a horizontal gradient from COLOR1 to COLOR2.
V	Displays a vertical gradient from COLOR1 to COLOR2.
H/V	Displays a diagonal gradient from COLOR1 to COLOR2.

5-10. Setting Up Additional Inputs

Up to 2 additional input cards can be installed into slots A and B.

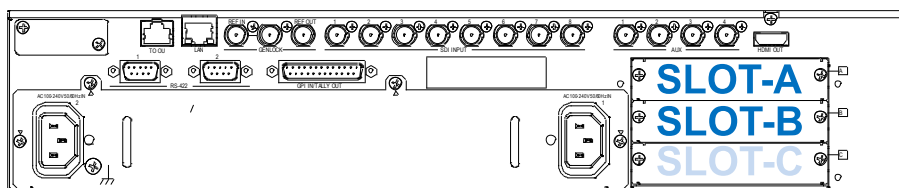

IMPORTANT

Note that the HVS-XT100DI-A card provides **four** inputs when installed into **SLOT-A**, however only **two** inputs are provided when installed into **SLOT-B**.

◆ Channel Name / Signal Name

Additional input channels on SLOT-A are called **INA1 to INA4**.

Additional input channels on SLOT-B are called **INB1 and INB2**.

Additional input names are initially assigned to **INPUT09 to INPUT14 (IN09 to IN14)**, which can be changed in the menu.

Use these names for additional input settings.

- ▶ To change signal names, see section 5-1. "How to Assign User Names to Sources."
- ▶ To assign inputs to bus buttons, see section 5-2. "How to Assign Sources to Bus Buttons."

SLOT-A

Input card	Number of inputs	Channel	Signal (Connector)	Channel name	Signal name
XT100DI-A	4	Ch1 Ch2 Ch3 Ch4	HD/SD SDI (BNC)	INA1 INA2 INA3 INA4	IN09 IN10 IN11 IN12
XT100AI	2	Ch1 Ch2	HD/SD analog component or Analog composite (BNC)	INA1 INA2	IN09 IN10
XT100PCI	2	Ch1	Digital RGB (HDMI)	INA1	IN09
		Ch2	Digital RGB (HDMI) / Analog RGB (VGA)	INA2	IN10

SLOT-B

XT100DI-A	2	Ch1 Ch2	(Same as those in SLOT-A)	INB1 INB2	If SLOT-A has 4 inputs: IN13 IN14 If SLOT-A has 2 inputs: IN11 IN12
XT100AI	2	(Same as those in SLOT-A)			
XT100PCI	2	(Same as those in SLOT-A)			

◆ Signal Setup

- Format settings are required for analog inputs.
- The HDMI or VGA must be selected for Ch2 of PC inputs.
- The SDI input formats are automatically detected.

Set up your additional inputs, referring to the following sections.

5-10-1. HVS-XT100DI-A

The XT100DI-A card accepts SDI signals.

No settings are necessary for these inputs, although Ch1 and Ch2 have **FORMAT** parameter settings. (See below.)

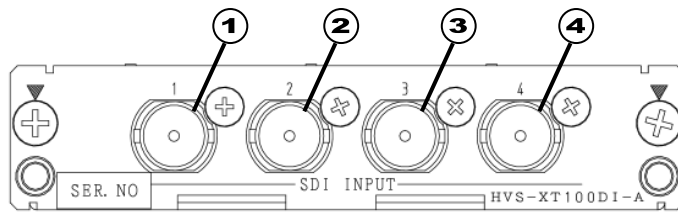

Open the [SETUP - INPUT - SIGNAL] menu. (The following setting uses the SLOT-A inputs as examples.)

Select a signal name under **SELECT** and a format under **FORMAT**, which is normally set to **AUTO** (default). When setting to **AUTO**, SD inputs are automatically up-converted when in HD mode. (See 5-10-4. "FS, INPUT STILL and Resize Functions.")

If HVS-XT100DI-A is installed into SLOT-A:

INPUT	: SELECT	: FORMAT	: RESIZE	: FS	: 1/4
SIGNAL	: =IN09	: = AUTO	: =4:3	: =OFF	:

NO	Channel	Connector	Input signal	SELECT setting	FORMAT setting
①	Ch1	BNC	HD SDI: 1080i /59.94, 50, 1080PsF /23.98, 24, 25, 29.97 720p /59.94, 50	IN09	AUTO * HD-SDI SD-SDI
②	Ch2			IN10	
③	Ch3		SD-SDI: NTSC, PAL	IN11	---
④	Ch4			IN12	

* When the switcher is running in HD mode, SD signals input to Ch1 and Ch2 are automatically up-converted (if they are at the same frame rate).

5-10-2. HVS-XT100AI

The XT100AI card accepts analog signals. Specify the analog signal format for each signal in the menu.

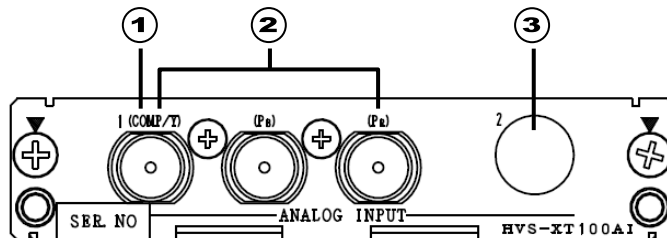

Open the [SETUP - INPUT - SIGNAL] menu. (The following setting uses the SLOT-A inputs as examples.) Select a signal name under **SELECT** and a format under **FORMAT** as shown in the table below.

If HVS-XT100AI is installed into SLOT-A:

INPUT	: SELECT	: FORMAT	: RESIZE	: FS	: 1/4
SIGNAL	: =IN09	: = HD-Comp	: =---	: =OFF	:

NO	Channel	Connector	Input signal	SELECT setting	FORMAT setting
①	CH1	BNC	Composite	IN09	HD Component SD Component Composite
②			HD/SD component (Y/P _B /P _R)		
③	CH2	Mini-DIN (7-pin) (*1)	HD/SD component (Y/P _B /P _R) or Composite	IN10	

(*1) Use the supplied conversion cable (PC-3275) to input a signal. Secure the Mini-DIN connector of the conversion cable to the card connector with the supplied connector retainer.

HVS-Xt100AI Supported Signals

System format	HD Component	Composite	Component SMPTE	Component BetaCam	Component
1080/59.94i 1080/29.97PsF 720/59.94p	✓	✓*	✓	✓*	-
1080/50i 1080/25PsF 720/50p	✓	✓	-	-	✓
525/60	-	✓*	✓	✓*	-
625/50	-	✓	-	-	✓
Other than those above	✓	—	-	-	-

✓: Acceptable

-: Unacceptable

*: If 7.5% Setup is added to a signal, the symbol "+" follows immediately after the name of the signal. The system format means the format specified in the [SETUP - SYSTEM - FORMAT] menu.

5-10-3. HVS-Xt100PCI

The Xt100PCI card accepts HDMI and VGA signals.
Set up for **Ch2** in the menu.

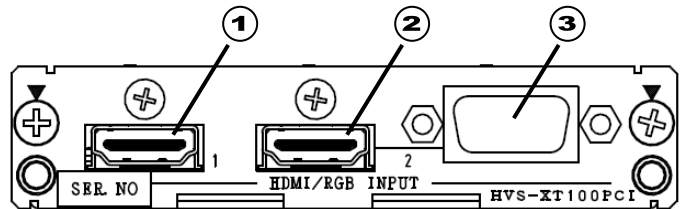

Open the [SETUP - INPUT - SIGNAL] menu. (The following setting uses the SLOT-A inputs as examples.) Set the Ch2 signal name under **SELECT** and select between **HDMI** (default) and **VGA** under **FORMAT** as shown in the table below. The resolution is auto-detected.

If HVS-Xt100PCI (Ch2) is installed into SLOT-A:

INPUT	: SELECT	: FORMAT	: RESIZE	: FS	: 1/4
SIGNAL	: =IN10	: = HDMI	: =NORML	: =OFF	:

NO	Channel	Connector	Input signal (See the table below.)	SELECT setting	FORMAT setting
①	CH1	HDMI	Digital RGB	IN09	AUTO
②	CH2	HDMI	Digital RGB	IN10	HDMI VGA
③		VGA	Analog RGB		

HVS-Xt100PCI Supported Signals

Format	Resolution
1080i/PsF *	1024x768 (XGA), 1280x1024 (SXGA), 1600x1200 (UXGA), 1280x768 (WXGA), 1920x1200 (WUXGA)
720p	1024x768 (XGA), 1280x1024 (SXGA), 1280x768 (WXGA)
SD (NTSC)	640x480 (VGA), 800x600 (SVGA), 1024x768 (XGA)
SD (PAL)	640x480 (VGA), 800x600 (SVGA), 1024x768 (XGA)

- * Video signals are unsupported if the switcher is running in 1080/23.98PsF or 1080/24PsF format.
- * The card is not HDCP-compliant and cannot accept inputs from HDCP-compliant devices such as Blu-ray players.

5-10-4. FS, INPUT STILL and Resize Functions

Almost the same functions as those for standard inputs can be applied to additional inputs, such as Frame Synchronizer and Input Still. See sections from 5-3 to 5-7 for details on each function.

Note that the Resize function has some restrictions associated with the additional inputs.

◆ Resize Function

A resize function allows users to input SD signals at the same frame-rate as that in HD mode, and enlarge them to use as HD images.

IMPORTANT

Note that the resize function is available on **Ch1** and **Ch2** of the HVS-XT100DI-A card, but **not** on **Ch3** and **Ch4**.

HVS-XT100DI-A/XT100AI

▶ See section 5-3. "Resize Function."

HVS-XT100PCI

The following settings are available when inputting PC signals with a 4:3 aspect ratio.

RESIZE setting	Description
NORMAL	Adds black bars on both sides.
FULL	Enlarges the picture to a 16:9 aspect ratio.
ZOOM	Cuts off the picture horizontally, and enlarges the picture to the full-screen size, while preserving the aspect ratio.

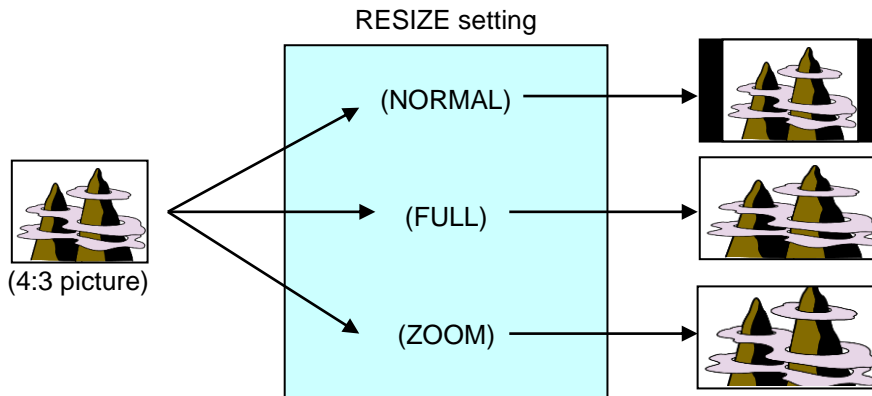

```

INPUT   : SELECT : FORMAT:RESIZE : FS   : 1/4
SIGNAL  : =IN09  :=AUTO  : =NORML: =OFF :
    
```

6. Video Outputs

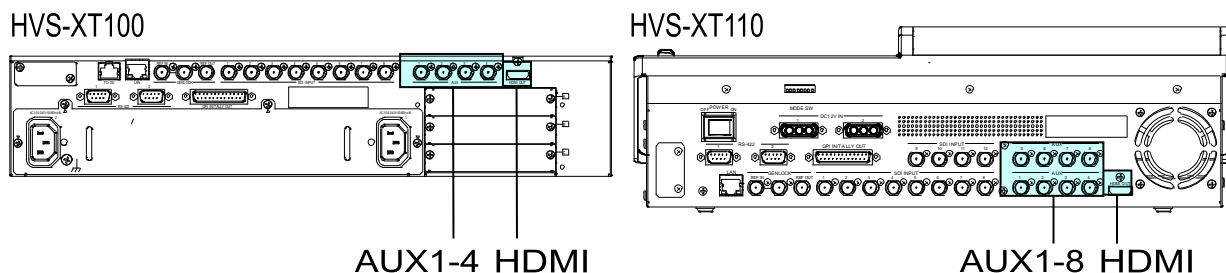

6-1. Aux Outputs

The switcher does not have any dedicated outputs for combined video such as Program or Preview images. Instead, eight user-assignable AUX ports are provided. AUX output signals can be selected from all bus sources (primary inputs, stills, mattes, etc.), program, preview, clean and key out signals. There are two signal selection procedures for auxiliary outputs: via bus buttons or from menu selection. If you want to select a signal easily and quickly, select the signal in the KEY/AUX bus. If you want to select a signal not assigned to bus buttons, select it in the menu.

6-1-1. Selecting Video via Bus Buttons

AUX1-4 outputs can select signals using the bus buttons.

(1) Press an AUX button, from AUX1 to AUX4 indicated below.

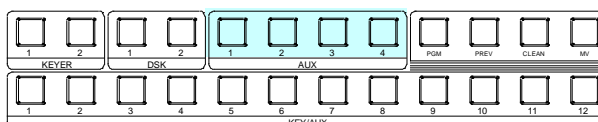

(2) Press a button in the KEY/AUX bus section to select a signal for the selected AUX output.

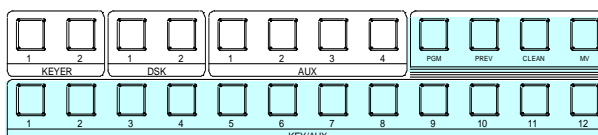

AUX5 to AUX8 bus buttons can be assigned to USER buttons.

▶ See section 14. "USER Buttons."

6-1-2. Selecting Video from Menu Selection

(1) Double-press an AUX button (AUX1 to AUX4) on the left side of the control panel to display the [SETUP - OUTPUT - OUT XPT] menu.

(2) Turn F1 to select an AUX bus.

(3) Turn F2 to select a video signal.

OUTPUT	: SELECT	: XPT	: TRANS RATE	: 1/3
OUT XPT	: =AUX1	: =IN01	: En=OFF	=OFF :

Available signal selections are as described below:

Button	Signal	Refer to
BLACK, IN01-14 STILL1-2, STILLK1-2, CKFIL, CKKEY, MATT1-2, CLBAR, EFF1-2	Signals assignable to M/E and KEY/AUX bus buttons	5-2
PGM	Program video	
PREV	Preview video (next video with or without KEY1-2 and DSK1-2)	6-2
CLEAN	Clean video (program video with or without KEY1-2 and DSK1-2)	6-3
KEY	Key cut signal combined with Key, DSK and DVE	6-4
MV	Multiviewer video	13-1

(4) To prevent operational errors, AUX signal selection via bus buttons can be disabled by setting **INHIBIT** to **ON** in the [SETUP - OUTPUT - OUT XPT] (2/3) menu.

```

OUTPUT :M/E KEY:      :  AUX INHIBIT  : 2/3
OUT XPT : =MEKEY:     : S=AUX1   En=ON  :
    
```

6-1-3. AUX Video Switching with Effects

The background video displayed on an AUX bus can be easily switched using effects. The auxiliary video can be changed using crossfade transitions. This chapter explains how to switch AUX video using an operational example.

Ex.) : Changes the AUX1 video in 30 frames using a crossfade.

- (1) Double-press **AUX1** on the left side of the control panel to display the [SETUP - OUTPUT - OUT XPT] (1/3) menu.
- (2) Turn **F1** to select AUX1.
- (3) Turn **F3** to set TRNS RATE En (Enable) to **ON**.
- (4) Turn **F4** to set TRANS RATE to **30** frames.

```

OUTPUT :SELECT : XPT   :  TRANS RATE   : 1/3
OUT XPT : =AUX1 : =IN01 :En=ON   =30  :
    
```

(5) Turn **F2** to select the next video. The current video will fade out and a new image will fade into the screen in 30 frames.

```

OUTPUT :SELECT : XPT   :  TRANS RATE   : 1/3
OUT XPT : =AUX1 : =IN05 :En=ON     =30   :
    
```

(6) Let's change the AUX1 video on the control panel. Press **AUX1** then select a video in the KEY/AUX bus.

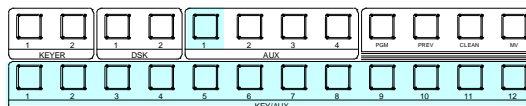

AUX bus transition effects are enabled when video input, matte, still or program signals are assigned to the AUX outputs. When multi-view images are assigned to AUX buses, however, video streams are switched using CUT.

6-2. Preview Set Up

The switcher does not have a dedicated PREVIEW output. A preview bus output can be assigned to, however, an AUX output. Users can also add key images to PREVIEW. This can be done as explained below:

6-2-1. Preview Bus Monitoring

Follow the procedure below to assign a preview video to an AUX output. AUX1 is used in the example below.

- (1) Double-press **AUX1** on the left side of the control panel to display the [SETUP - OUTPUT - OUT XPT] (1/3) menu.
- (2) Turn **F1** to select **AUX1**.
- (3) Turn **F2** to select **PVW**.

OUTPUT	: SELECT	: XPT	: TRANS RATE	: 1/3
OUT XPT	: = AUX1	: = PVW	: En=OFF	=0 :

6-2-2. Setting Up Preview Images

- (1) Double-press **PREV** to display the [SETUP - OUTPUT - CLN/PREV] (2/2) menu.
- (2) Turn **F1** to **F4** to set whether the key images are to be displayed on the preview image, then press the push-button to confirm the setting for each.

OUTPUT	: KEY1	: KEY2	: DSK1	: DSK2	: 2/2
M/E PRV	: = ON	: = ON	: = OFF	: = OFF	:

KEY1-2

Parameter	Setting	NEXT TRANSITION	KEY On-Air/Off-Air	KEY1-2 on PREVIEW images
PREVIEW OUT - KEY1	ON	KEY1 button ON	On-Air	Not displayed
	ON	KEY1 button OFF	On-Air	Displayed
PREVIEW OUT - KEY2	ON	KEY2 button ON	Off-Air	Displayed
	ON	KEY2 button OFF	Off-Air	Not displayed
PREVIEW OUT - KEY1-2	OFF	---	---	Not displayed

Whether KEY images are displayed on the preview depends on both the PREVIEW OUT settings and KEY button status in the NEXT Transition block.

DSK 1-2

Parameter	Setting	DSK1-2 on PREVIEW images
PREVIEW OUT - DSK1	ON	Displayed
PREVIEW OUT - DSK2	OFF	Not displayed

6-3. Clean Set Up

The switcher can output CLEAN video (background video of the program signal) via an auxiliary output. Users can also add KEY or DSK images to CLEAN. Follow the procedure below to assign the clean video to an AUX output. AUX3 is used in this example.

Outputting the Clean Video from AUX 3

- (1) Double-press **AUX1** to display the [SETUP - OUTPUT- OUT XPT](1/3) menu.
- (2) Turn **F1** to select AUX3.
- (3) Turn **F2** to select CLN.

OUTPUT	:SELECT	: XPT	: TRANS RATE	: 1/3
OUT XPT	: = AUX3	: = CLN	: En=OFF	=0 :

Displaying KEY1-2 and DSK1-2 Images on the Clean Video

- (1) Double-press **CLEAN** to display the [SETUP - OUTPUT - CLN/PREV] (1/2) menu.
- (2) Turn **F1** to set KEY1 to **ON**. Then press **F1** to confirm the setting.
- (3) Set KEY2 and DSK1-2 in the same way.

OUTPUT	: KEY1	: KEY2	: DSK1	: DSK2	: 1/2
M/E CLN	: = ON	: = ON	: = ON	: = ON	:

6-4. KEY OUT Set Up

The KEY OUT signal, switcher processed key cut signal (alpha channel), can be assigned to AUX outputs. Various kinds of key cut signals can be used for KEY OUT sources.

- (1) Open [SETUP - OUTPUT - OUT XPT] menu PAGE 2.

OUTPUT	:M/E KEY:	: AUX INHIBIT	: 2/3
OUT XPT	: = MEKEY :	: S=AUX1	En=OFF :

- (3) Turn **F1** to select a KEY OUT signal. Various types of KEY OUT signals are available as shown in the table below. Press **F1** or **ENTER** to confirm the setting.

Item	Setting	Description
M/E KEY	PGM	Key signal of PGM when using DVE
	PST	Key signal of PST when using DVE
	ME A	Key signal of M/E-A when using DVE
	ME B	Key signal of M/E-B when using DVE
	KEY1, KEY2	Key signal of each KEY1 or KEY2
	DSK1, DSK2	Key signal of each DSK1 or DSK2
	MEKEY	Key signal of program including KEY1-2 and DSK1-2

6-5. HDMI Output

Video output through the HDMI port can be selected from an M/E program, preview, clean or key out video, to AUX1-8 and MV.

- (1) Double-press **AUX1** on the left side of the control panel to display the [SETUP - OUTPUT - OUT XPT] (1/3) menu.
- (2) Press the page down button to go to PAGE 3.
- (3) Turn **F1** to select a video to be output from the HDMI port.

Available options are:

**PGM, PREV, CLEAN, MEKY
AUX1-8, MV**

System Format	Output signal format
1080i 1080PsF (*1)	HDTV (1920 x 1080i)
720p	HDTV (1280 x 720p)
PAL (SDTV)	SDTV (720 x 576i)
NTSC (SDTV)	SDTV (720 x 480i)

Signals are output at the same frequency as that of the system format.

(*1) Video signals cannot be output from the HDMI port if the switcher is running in 1080/23.98PsF or 1080/24PsF format.

◆ Ex. 1

Switcher System Format: 1080/59.94i

To Output the PGM video (at 1920 x 1080 resolution):

OUTPUT	:	XPT	:	:	3/3
HDMI OUT:	=	PGM	:	:	

◆ Ex. 2

Switcher System Format: 720/50p

To Output the AUX1 video (at 1280 x 720 resolution):

OUTPUT	:	XPT	:	:	3/3
HDMI OUT:	=	AUX1	:	:	

◆ Ex. 3

Switcher System Format: SD PAL (625/50)

To Output the MV SDTV video:

OUTPUT	:	XPT	:	:	3/3
HDMI OUT:	=	MV	:	:	

6-6. Setting Up Additional Outputs

Up to 2 additional output cards can be installed into slots B and C.

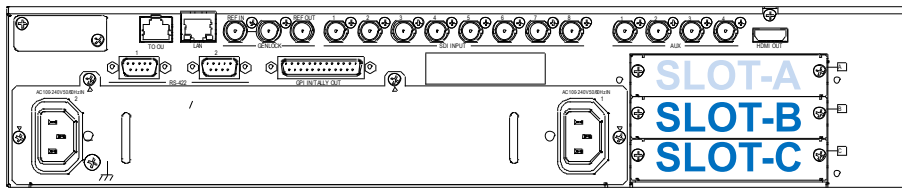

◆ Channel Name

Additional output channels on SLOT-B are called **B-Ch1** and **B-Ch2**.

Additional output channels on SLOT-C are called **C-Ch1** and **C-Ch2**.

Use these names for additional output settings.

The OUTPUT settings for these channels are initially assigned to **AUX5 to AUX8**, which are applied in numerical order.

SLOT-B/SLOT-C

Output card	Number of outputs	Channel	Signal (Connector)	Channel name	OUTPUT setting (*2)
XT100DO	2 (*1)	Ch1 Ch2	HD/SD SDI (BNC)	If installed in SLOT-B:	AUX1 to 8 MV
XT100AO	2	Ch1 Ch2	HD/SD analog component or analog composite (BNC)	B-Ch1 B-Ch2	
XT100PC O	2	Ch1	Digital RGB (HDMI)	If installed in SLOT-C:	
		Ch2	Digital RGB (HDMI) / Analog RGB or Y/Pb/Pr (VGA)		

(*1) Each channel in the HVS-XT100DO card has a simultaneous SD output feature. When operating in HD mode, the simultaneous output outputs the down-converted SD signal.

(*2) This setting is in the [SETUP - OUTPUT - OPTION] menu. See the following pages.

◆ Output Setting

Available formats for additional output signals vary depending on the system format (the format set in the [SETUP - SYSTEM - FORMAT] menu).

- Format settings are required for each analog output.
- A resolution must be selected for each PC output.
- Only the aspect ratio of simultaneous outputs can be selected for SDI outputs when the switcher is running in HD mode.

The Proc Amp, Safety Area marker and ANC pass-through functions can also be applied to additional outputs.

- ▶ See section 6-6-4. "Proc Amp" and 6-6-5. "Video Level Clip."
- ▶ See section 6-7. "Safety Area Markers."
- ▶ See section 6-8. "Ancillary Data."

Set up your additional outputs referring to the following sections.

6-6-1. HVS-XT100DO

The XT100DO card outputs SDI signals.

Note that outputs ③ and ④ are simultaneous SD outputs of ① and ②, respectively. (See the figure below.)

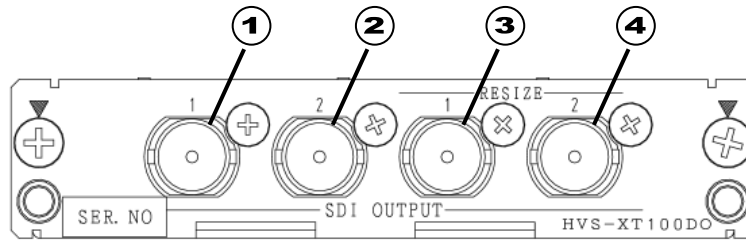

Open the [SETUP - OUTPUT - OPTION] menu. (The following procedure uses SLOT-B channels as examples.)

Only the aspect ratio of simultaneous outputs can be selected when operating in HD mode.

If the HVS-XT100DO is installed into SLOT-B:

OUTPUT	:SELECT	:OUTPUT	:FORMAT	:ASPECT	: 1/4
OPTION	: =B-Ch1:	=AUX5	: =SD-SDI:	=4:3	:

OUTPUT	:SELECT	:OUTPUT	:FORMAT	:ASPECT	: 1/4
OPTION	: =B-Ch2:	=AUX6	: =SD-SDI:	=4:3	:

Ch1 on SLOT-B

NO	System format	Menu settings		
		SELECT	FORMAT	ASPECT
①	HD SDI: 1080i /59.94, 50, 1080PsF /23.98, 24, 25, 29.97	B-Ch1	Outputs a signal in the system format.	
	SD-SDI: 720p /59.94, 50 NTSC, PAL		SD-SDI (fixed)	4:3 SQUEEZE LETTER
③	HD SDI: 1080i /59.94, 50, 1080PsF /29.97, 25 720p /59.94, 50		(No output)	
	HD SDI: 1080PsF /23.98, 24 (*1)		SD-SDI (fixed)	---
	SD-SDI: NTSC, PAL			

(*1) No signal is output from simultaneous output when the switcher is running in 1080/23.98PsF or 1080/24PsF mode.

When setting **Ch2** on **SLOT-B**, use **B-Ch2** to specify the output. The output process and settings are the same as those for Ch1.

6-6-2. HVS-XT100AO

The XT100AO card outputs analog signals.

Use the supplied conversion cable for the Ch2 output.

Follow the procedure below to specify the signal format for each channel in the menu.

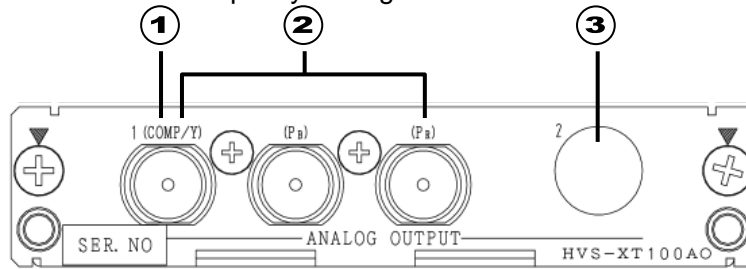

NO	Channel	Connector	Output signal	Connection
①	Ch1	BNC	Analog composite	Use the leftmost BNC connector.
②			HD/SD analog component (Y/Pb/Pr)	Use three (Y/Pb/Pr) BNC connectors.
③	Ch2	Mini-DIN (7-pin) (*1)	HD/SD analog component (Y/Pb/Pr) or analog composite	Use the supplied cable (PC-3275).

(*1) Secure the Mini-DIN connector of the conversion cable to the card connector with the supplied retainer.

Open the [SETUP - OUTPUT - OPTION] menu. (The following procedure uses SLOT-B channels as examples.)

The aspect ratio can also be selected if outputting SD component or composite video in HD mode.

If HVS-XT100AO is installed into SLOT-B:

```
OUTPUT :SELECT :OUTPUT :FORMAT :ASPECT : 1/4
OPTION  : =B-Ch1: =AUX5 : =Cmpst: =4:3 :
```

```
OUTPUT :SELECT :OUTPUT :FORMAT :ASPECT : 1/4
OPTION  : =B-Ch2: =AUX6 : =Cmpst: =4:3 :
```

HVS-XT100AO Supported Signals

System format	HD Component	Composite	Component SMPTE	Component BetaCam	Component
1080/59.94i 1080/29.97PsF 720/59.94p	✓	✓ (*1) (*2)	✓ (*2)	✓ (*1) (*2)	-
1080/50i 1080/25PsF 720/50p	✓	✓ (*2)	-	-	✓ (*2)
525/60	-	✓ (*1)	✓	✓ (*1)	-
625/50	-	✓	-	-	✓
Other than those above	✓	-	-	-	-

✓: Acceptable

-: Unacceptable

(*1): If 7.5% Setup is added to a signal, the symbol "+" follows immediately after the name of the signal.

The system format means the format specified in the [SETUP - SYSTEM - FORMAT] menu.

(*2): You can select 4:3, SQUEEZE or LETTER under ASPECT.

When setting **Ch2** on **SLOT-B**, use **B-Ch2** as the specified output. The output process and settings are the same as those for Ch1.

6-6-3. HVS-XT100PCO

The XT100PCO card outputs signals from HDMI ports.
The Ch2 signal can output from HDMI (②) and VGA (③). (See below.)

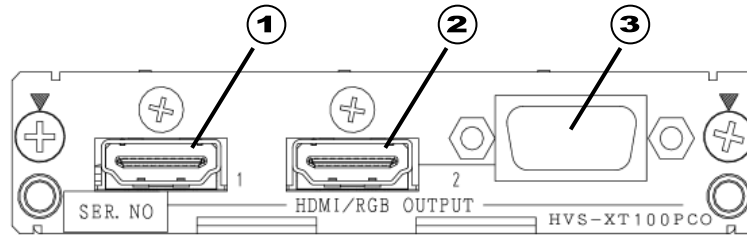

Open the [SETUP - OUTPUT - OPTION] menu. (The following procedure uses SLOT-B channels as examples.)

Select the resolution and aspect ratio for each channel.

If HVS-XT100PCO is installed into SLOT-B:

```
OUTPUT :SELECT :OUTPUT :FORMAT :ASPECT : 1/6
OPTION  : =B-Ch1: =AUX5 :=SXGA  : =4:3  :
```

```
OUTPUT :SELECT :OUTPUT :FORMAT :ASPECT : 1/6
OPTION  : =B-Ch2: =AUX6 :=SXGA  : =4:3  :
```

Ch1 on SLOT-B

NO	System format	Menu settings		
		SELECT	FORMAT	ASPECT
①	1080i 1080PsF (*1)	B-Ch1	1280x1024 (SXGA), 1600x1200 (UXGA)	4:3, LETTER
			1680x1050 (WSXGA) 1920x1200 (WUXGA), 1920x1080i (HDTV)	-----
			1280x1024 (SXGA)	4:3, LETTER
	1280x768 (WXGA), 1280x720p (HDTV)		-----	
	800x600 (SVGA)		4:3, 16:9 (*3)	
	720x576i (SDTV) (*2)		-----	
	800x600 (SVGA)		4:3, 16:9 (*3)	
	720x480i (SDTV) (*2)		-----	

(*1) Video signals cannot output from the PCO outputs if the switcher is running in 1080/23.98PsF or 1080/24PsF format.

(*2) HDMI only

(*3) Effective only when the Aspect Ratio of SYSTEM FORMAT in the switcher is set to SQUEEZE

You can choose between 60 Hz and 50 Hz for the output frequency if the switcher is running in 50 Hz mode (1080/50i, 25PsF, 720/50p or 625/50). In such cases, no signal outputs from VGA.

```
OUTPUT : HVS-XT100PCO V SCAN FREQUENCY : 6/6
OPTION  : B1=60Hz B2=60Hz C1=60Hz C2=60Hz :
```

Select audio from **Off**, **Ch1/2**, **Ch3/4**, **Ch5/6** and **Ch7/8**. Audio can only be output from the HDMI ports when selecting an HDTV or SDTV signal.

```
OUTPUT :SELECT : AUDIO : : 5/6
OPTION  : =B-Ch1 :=Ch1/2 : :
```

When setting **Ch2** on **SLOT-B**, use **B-Ch2** to specify the output. The output process and settings are the same as those for Ch1.

6-6-4. Proc Amp

The switcher provides a PROC AMP feature for additional outputs. Use the PROC AMP as shown below to adjust each output signal, if necessary.

- (1) Open the [SETUP - OUTPUT - OPTION] menu.
- (2) Press the [PAGE DOWN] button to go to PAGE2.
- (3) Turn [F1] to select an output signal to be adjusted.
- (4) Turn [F4] to set **ENABLE ON** to enable the PROC AMP.
- (5) Adjust the luminance level under **LumGain** and black level under **Setup**.

OUTPUT	:SELECT	:LumGain:	Setup	:ENABLE	: 2/5
PROC AMP:	=B-Ch1:	=1.00	: =0	: =ON	:

- (6) Press the [PAGE DOWN] button to go to PAGE3.
- (7) Adjust the chrominance level under **ChmGain** and the color under **Hue**.

OUTPUT	:SELECT	:ChmGain:	Hue	:ENABLE	: 3/5
PROC AMP:	=B-Ch1:	=10.00:	=0.0	: =ON	:

6-6-5. Video Level Clip

To maintain the desired signal level after adjusting video levels with the Proc Amp, use the Video Level Clip function to adjust the upper and lower YPbPr color space limits. Note that the Video Level Clip settings are applied to all outputs in which the Proc Amp is enabled.

- (1) Refer to the section 6-6-4. "Proc Amp" to enable the PROC AMP.

OUTPUT	:SELECT	:LumGain:	Setup	:ENABLE	: 2/5
PROC AMP:	=B-Ch1:	=1.00	: =0	: = ON	:

- (2) Go to PAGE 4.
- (3) Set the signal level limits under **WHT-Lv**, **BLK-Lv** and **Chroma** respectively.

OUTPUT	:WHT-Lv	:BLK-Lv	:Chroma	:	: 4/5
CLIP	: =1019	: =4	: =1100	:	:

6-7. Safety Area Markers

Various markers indicating the safety area, screen center and aspect ratio can be displayed on the desired output.

- (1) Open the [SETUP - OUTPUT] menu.
- (2) Turn **F1** to select **MARKER**, then press **F1** or the page down button to open the [SETUP - OUTPUT - MARKER] menu.
- (3) Turn **F1** to select a video output.

XT100	XT110
AUX1 to AUX4 B-Ch1, B-Ch2 (Additional outputs on Slot B) C-Ch1, C-Ch2(Additional outputs on Slot C) HDMI	AUX1 to AUX8 HDMI (HDMI OUTPUT)

- (4) Turn **F2** to set to **ON** then press **F2** to enable the Marker function.

```
OUTPUT :SELECT :ENABLE :MARKER :SIDECUT: 1/2
MARKER : =AUX1 : =ON : =BOX : =OFF :
```

Safety Area Marker

To display a safety area marker in the selected output, first select the type of marker under the **MARKER** item in the [SETUP - OUTPUT - MARKER] menu from **BOX** and **HOOK**. (See the figures at the bottom of the page.) Then go to **PAGE 2**, select an aspect ratio, and set the marker size.

```
OUTPUT :SELECT :ENABLE :MARKER :SIDECUT: 1/2
MARKER : =AUX1 : =ON : =BOX : =OFF :
```

```
OUTPUT :ASPECT : SIZE :CENTER : : 2/2
MARKER : =16:9 : =85% : =ON : :
```

Center Marker

To display the center marker in the selected output, set **CENTER** to **ON** in **PAGE 2** of the [SETUP - OUTPUT - MARKER] menu. (See the figures at the bottom of the page.)

```
OUTPUT :ASPECT : SIZE :CENTER : : 2/2
MARKER : =16:9 : =85% : =ON : :
```

Side Cut Display

To display a Side Cut image converting the aspect ratio from 16:9 to 4:3, select the display type under the **SIDECUT** item. Available types are **LINE**, **BLACK** and **HALF**. (See the figures at the bottom of the page.)

```
OUTPUT :SELECT :ENABLE :MARKER :SIDECUT: 1/2
MARKER : =AUX1 : =ON : =OFF : =BLACK:
```

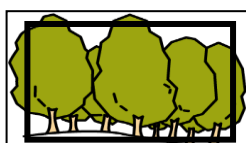

MARKER: BOX
ASPECT: 16:9
SIZE: 85%

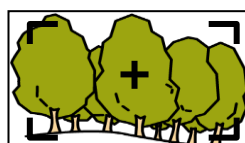

MARKER: HOOK
ASPECT: 16:9
SIZE: 85%
CENTER: ON

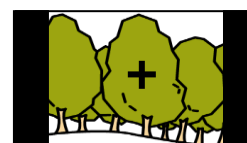

MARKER: OFF
SIDECUT: BLACK
CENTER: ON

6-8. Ancillary Data

Ancillary data does **not pass through all outputs** as the **factory default** setting. The switcher can be set to pass or blank the ancillary data in the outputs using the menu. The switcher also allows users to pass or substitute ancillary data in the Program (Clean) and Preview video. Ancillary data in the current video stream is once cleared, then the same or different data inserted. Ancillary data operation is set in the [SETUP - OUTPUT - ANCI] menu.

Ancillary data in input video cannot be passed through if **FS** (input frame synchronizer) is set to **ON** or **RESIZE** is enabled. To pass ancillary data, input the video synchronized with the genlock signal and set **FS** to **OFF**.

► See section 5-3. "Resize Function" and section 5-7. "Frame Synchronizer."

Note that ancillary data in SD inputs cannot be used when the switcher operates in HD mode.

6-8-1. Passing Incoming Ancillary Data

- (1) Open the [SETUP - OUTPUT - ANCI] menu PAGE 2.
- (2) Turn **F1** to select an output, then turn **F2** to set to **ON** (pass).

OUTPUT	:	SELECT	:	ENABLE	:		:	2/2
ANCI THR:		=AUX1	:	=ON	:		:	

6-8-2. Ancillary Data in PGM and PREV Bus Signals

◆ Program (Clean) bus

To Pass Through Ancillary Data

Turn **F1** to select **EACH**. The Lv (level) item selects the point at which the new data is to be inserted, from 0-100. Setting **Lv** to **50** passes ancillary data through from the halfway point of the background transition.

OUTPUT	:	M/E PGM SWAP	:	PREV SW:	:		:	1/2
ANCI SWP:		=EACH	:	LV=50	:	=OFF	:	

To Replace Ancillary Data with Data in an AUX bus signal

Turn **F1** to select **AUX1**. Ancillary data in the program bus signal is replaced with ancillary data in AUX1 video. (Note that the **Lv** setting is ignored.)

OUTPUT	:	M/E PGM SWAP	:	PREV SW:	:		:	1/2
ANCI SWP:		=AUX1	:	LV=50	:	=OFF	:	

◆ Preview bus

Ancillary data in the Preview bus signal can be processed in the same way as that for the program bus under **PREV SW**.

OUTPUT	:	M/E PGM SWAP	:	PREV SW:	:		:	1/2
ANCI SWP:		=AUX1	:	LV=50	:	=EACH	:	

6-9. AUX LINK

In the AUX-LINK function, the auxiliary outputs are grouped, and the master and slave outputs are set to allow all slave output signals to be switched simultaneously by simply selecting the master output signal. A group consists of one master output and up to three slave outputs. Seven auxiliary output groups can be set. Examples of AUX LINK settings and operation are shown below.

6-9-1. Creating AUX Output Link Groups

- (1) Open the [SETUP - FUNCTION] menu. Turn **F1** to select **AUX LINK**. Press **F1** or the page down button to display the AUX LINK menu.

```

SETUP    :>M/E_KEY >VIRTUAL >AUX LINK
FUNCTION:
  
```

```

FUNCTION:ENABLE :                : 1/3
AUX LINK: =OFF  :                :
  
```

- (2) Press the page down button again to go to the [AUX LINK - AUX GRP] menu page.

```

FUNCTION:SELECT:MASTER:  SLAVE SEL/AUX : 2/3
AUX GRP : =1    : =AUX1:1=AUX2  2=AUX3 3=AUX4
  
```

- (3) Turn **F1** to select a group to be set from 1-7
 (4) Turn **F2** to set the auxiliary output serving as the MASTER. Available outputs are shown below.

Master Output	AUX1-8, PGM, PST ABUS, BBUS, KEY1, KEY2, DSK1, DSK2
---------------	--

- (5) Select the auxiliary outputs (up to three) serving as the SLAVE linking to the MASTER output. Available outputs are shown below. Press **F3** and then turn **F3** to select an output for Slave 1. Press **F3** and then turn **F3** to select an output for Slave 2. Select an output for Slave 3 in the same way.

Slave Output (Normal link)	Same options as Master Output. Note that video set as Master cannot be selected for the Slave.
-------------------------------	---

The A or B bus cannot be set for Slave when the Program or Preset bus is selected for Master. In the same way, the Program or Preset bus cannot be set for Slave output when the A or B bus is selected for Master.

6-9-2. Creating Signal Link Groups

- (1) Press the page down button to go to the [AUX LINK - LINK GRP] menu.

```

FUNCTION:SELECT:MASTER:  SLAVE SEL/AUX : 3/3
LINK GRP: =1    : =IN01:1=IN02  2=IN03 3=IN04
  
```

Available Signals	BLK, IN01 to 14, STL1, STL2, STK1, STK2, CKFL, CKKY, EFF1, EFF2, CB, MAT1, MAT2
(If an AUX bus is selected for the MASTER or SLAVE bus)	PGM, PVW, CLN, MEKY, MV

- (2) Turn **F1** to select an AUX LINK group to be set in the LINK GROUP menu (up to 20 groups).
- (3) Turn **F2** to select a signal to be set for MASTER
- (4) To set the SLAVE output signals (up to three) that link to the MASTER output signal, press **F3** and then turn **F3** to select a signal for Slave 1. Press **F3** and then turn **F3** to select a signal for Slave 2. Select a signal for Slave 3 in the same way.

NOTE

The same MASTER output signal cannot be selected twice. SLAVE output signals can be selected multiple times.

6-9-3. Enabling AUX LINK

- (1) Display the [SETUP - FUNCTION - AUX LINK] menu.
- (2) Turn **F1** to set ENABLE to ON. This activates all AUX LINK groups.

```
FUNCTION: ENABLE : : 1/3
AUX LINK: =ON : :
```

◆ **Operation examples:**

Assume that the AUX output link groups and their signal link groups were set as shown below.

```
      :SELECT:MASTER:  SLAVE SEL/AUX : 2/3
AUX GRP : =1      : =AUX1 :1=AUX2 2=AUX3 3=AUX4
          : =2      : =AUX7 :1=AUX8 2=OFF  3=OFF
          : =3      : =PGM  :1=KEY1 2=KEY2 3=OFF
          : =4      : =ME-A :1=ME-B 2=OFF  3=OFF
          : =5      : =OFF  :1=---  2=---  3=---
          : ...    : ...   :       : ...
```

```
      :SELECT:MASTER:  SLAVE SEL/AUX : 3/3
LINK GRP: =1      : =IN01 :1=IN02 2=IN03 3=IN04
          : =2      : =PGM  :1=PREV 2=OFF  3=OFF
          : =3      : =IN05 :1=STL1 2=STL2 3=OFF
          : =4      : =IN06 :1=IN07 2=OFF  3=OFF
          : =5      : =OFF  :1=---  2=---  3=---
          : ...    : ...   :       : ...
```

Press **AUX1** in the BUS SELECT-AUX block and select **IN01** on the AUX/KEY bus:
 >> IN02 is assigned to AUX2, IN03 to AUX3 and IN04 to AUX4.

Press **AUX7** in the BUS SELECT-AUX block and select **PGM**:
 >> PREV is assigned to AUX8.

Select **IN05** in **PGM** bus:
 >> STL1 is assigned to KEY1-INSERT and STL2 to KEY2-INSERT.

Select **IN06** in M/E- A bus:
 >> IN07 is assigned to M/E-B bus

7. Bus Operation

Video signals that are input to the switcher are assigned to the bus buttons on the control panel for usage. The assigned signals are shared by the M/E(PGM/PST) and KEY/AUX bus sections. As factory default settings, video inputs, Stills and Mattes are assigned to the bus buttons. The video source assignments are freely changeable. To prevent accidental button operation, the Button Inhibit function is also available.

▶ See section 5-2. "How to Assign Sources to Bus Buttons."

7-1. Selecting Video Sources

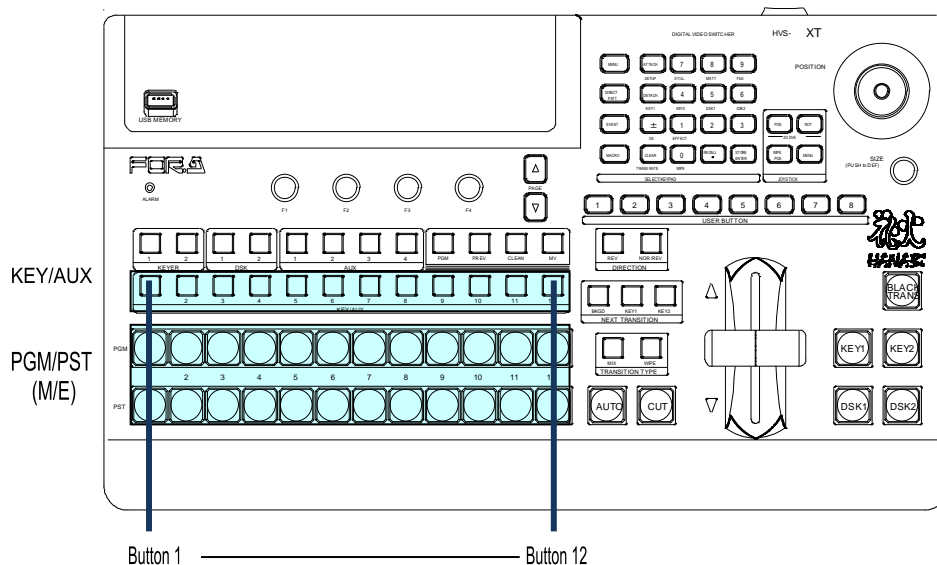

7-1-1. Selecting Video Sources on the PGM/PST

Press the desired bus button on the **PGM** bus. The button light will turn red and the video signal assigned to the selected bus button is displayed on the **program output** screen.

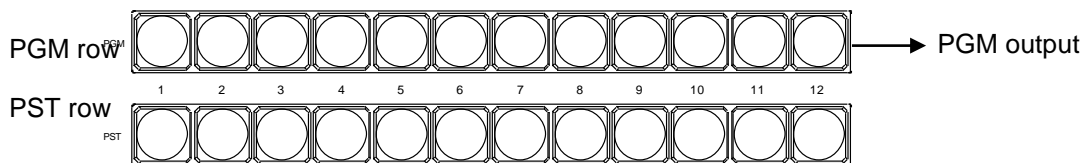

Press the desired bus button on the **PST** bus. The button light will turn orange and the video signal assigned to the selected bus button is displayed on the **preview output** screen. Then move the fader lever from end to end to check how the button indication changes as the signals are switched. Once the transition is complete, the selected signals on PGM and PST are switched (flip-flop).

The switcher's primary operation is to select the next video on the PST bus and send it to air via transition. And to repeat the process over and over.

Users can change the M/E bus mode from PGM/PST to A/B.

▶ See section 7-2. "Button Switching Mode in M/E Bus."

7-1-2. Selecting Video Sources for AUX1 to AUX4

- (1) Press the desired AUX button.
- (2) Press a desired button on the KEY/AUX bus.

Ex.1) To Select IN1 for AUX1
Press **AUX1**. Then press **1** (IN01) on the KEY/AUX.

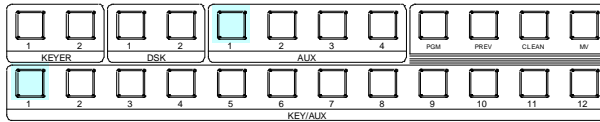

Ex. 2) To Select PREV for AUX2
Press **AUX2**. Then press **PREV** on the KEY/AUX.

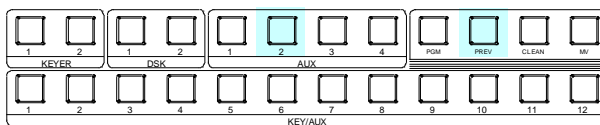

7-1-3. Selecting Video Sources for KEY and DSK

To select the bus button 4 video for KEY1 Insert (fill) and the bus button 5 video for KEY1 Source (key), proceed as follows.

- (1) Press **KEY1**.

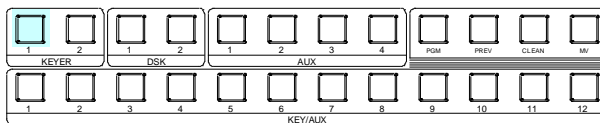

- (2) Press **4** in the KEY/AUX bus to select the KEY1 Insert signal.

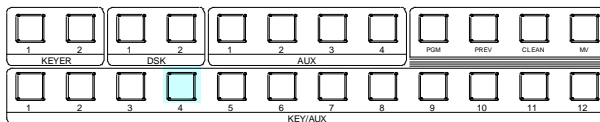

- (3) While holding down **KEY1**, press **5** in the KEY/AUX bus to select the KEY1 Source signal.

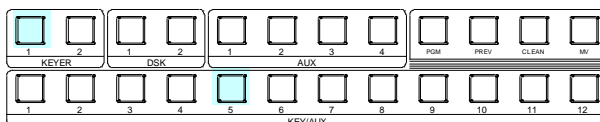

Once insert and source signals are selected for a key or DSK, they are stored as a key pair and when a key or DSK then selects an insert signal, the paired source signal is automatically set.

► See section 9-3-1. "Key Link."

7-2. Button Switching Mode in the M/E Bus

Users can change the button switching mode for the M/E bus from P/P (PGM/PST) to A/B. In P/P mode (default), the source selections in the PGM and PST buses are switched when transitions occur and users can always select the next background signal from the PST bus (the bottom row). In A/B mode, the source selections in the PGM and PST buses do not switch when transitions occur and the next signal selection takes place in the different bus after each transition.

To Change the Switching Mode to A/B:

- (1) Press **MENU** then **SETUP** in the SELECT/KEYPAD block to display the SETUP menu top page. Turn **F1** to select **PANEL**. Press **F1** or the page down button to display the [SETUP - PANEL] menu.
- (2) Turn **F1** to select **TRS CTRL**. Press **F1** or the page down button to display the [SETUP - PANEL - M/E CTRL] menu.
- (3) Turn **F1** to select **A/B**. Press **F1** or **ENTER** on the keypad to confirm the setting.

PANEL	: BUSTYPE:	:	FADER OFFSET	: 1/1
M/E CTRL:	= A/B	:	:U=1.00 L=1.00	:

7-3. Setting-up and Using the SHIFT Function

Users can select a video signal from 12 sources on the control panel, because each bus row has 12 buttons. The SHIFT function can also be assigned to a bus button in the same way video sources can. The SHIFT button allows users to select a video signal among 22 sources on the panel. (The SHIFT button is also available on the KEY/AUX bus.) The SHIFT function is not assigned to a button by default. To use the SHIFT function, assign it to a bus button as shown in the procedure below.

7-3-1. Assigning the SHIFT Function to a Bus Button:

- (1) Press **MENU** then **SETUP** in the SELECT/KEYPAD block to display the SETUP menu top page. Turn **F1** to select **INPUT**. Press **F1** or the page down button to display the [SETUP - INPUT] menu.
- (2) Turn **F1** to select **ASSIGN**. Press **F1** or the page down button to display the [SETUP - INPUT - ASSIGN] menu.

SETUP	:>SIGNAL	>PROC AMP>RENAME	> ASSIGN
INPUT	:>COLORBAR		

- (3) Turn **F1** to select a bus button for use.
- (4) Turn **F2** or **F3** to select **SHIFT** under **SIGNAL**.

INPUT	: BUTTON	: SIGNAL NAME	: INHIBIT:	1/3
OU ASGN	: = 12	: = SHIFT = SHIFT	: =OFF	:

7-3-2. Using the SHIFT Function

Once the SHIFT function has been assigned to a bus button, an additional 11 buttons are available for signal selection.

This chapter explains how to select signals with the SHIFT button. Assume that video sources and the shift function are assigned to bus buttons as shown in the table below:

Bus button 1	IN01
Bus button 1 (shifted)	STILL1
Bus button 12	SHIFT function

Now, let's select **IN01** on **PGM** and **STILL1** on **PST**.

When SHIFT works in NORMAL mode:

Shifted buttons are enabled while holding down SHIFT.

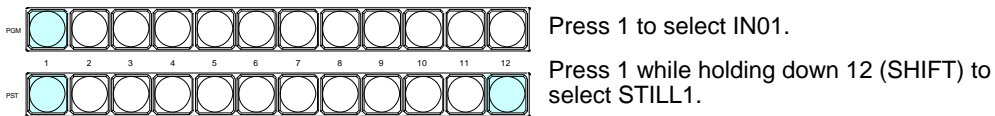

When SHIFT works in TOGGLE mode:

To select shifted buttons, press SHIFT then press a bus button.

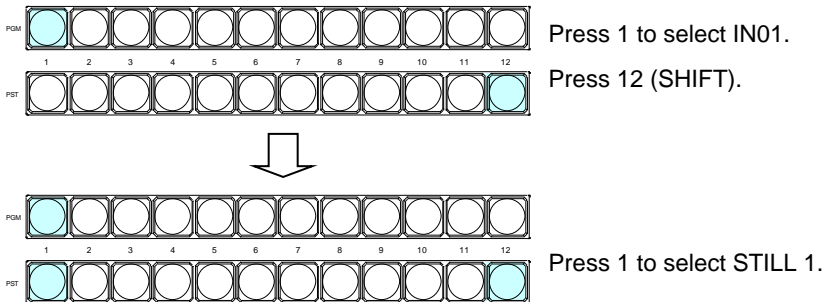

The SHIFT setting (NORMAL or TOGGLE) can be selected in the [SETUP - INPUT - ASSIGN] (3/3) menu.

8. Transitions

Available Transitions on the M/E (PGM/PST) bus

- BLACK transition: MIX
- Background: CUT, MIX and Pattern transitions
- KEY1 and 2: CUT, MIX and Pattern transitions
SLIDE (4-direction), SCALER and WIPE (4-direction) transitions
- DSK1 and 2: CUT and MIX transitions
SLIDE (4-direction), SCALER and WIPE (4-direction) transitions

- Transitions setup by next transition bus selection
- Transitions using the **AUTO** button or fader lever
- More than 130 types of various preset patterns
- Simultaneous background and key pattern transitions

◆ Transition Example

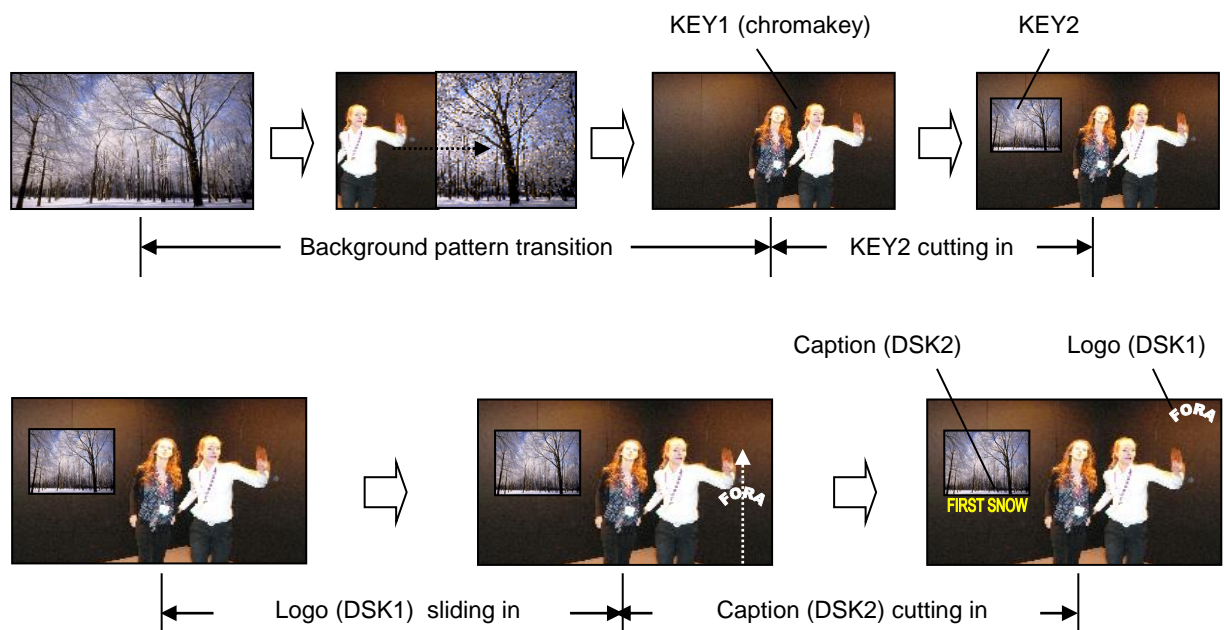

Other Transitions

- AUX crosspoint switching with effects
 - ▶ See section 6-1-3. "AUX Video Switching with Effects."
- Transitions using Event Recall
 - ▶ See section 15-5. "Transitions Using Event Recall."

8-1. Transition Block Description

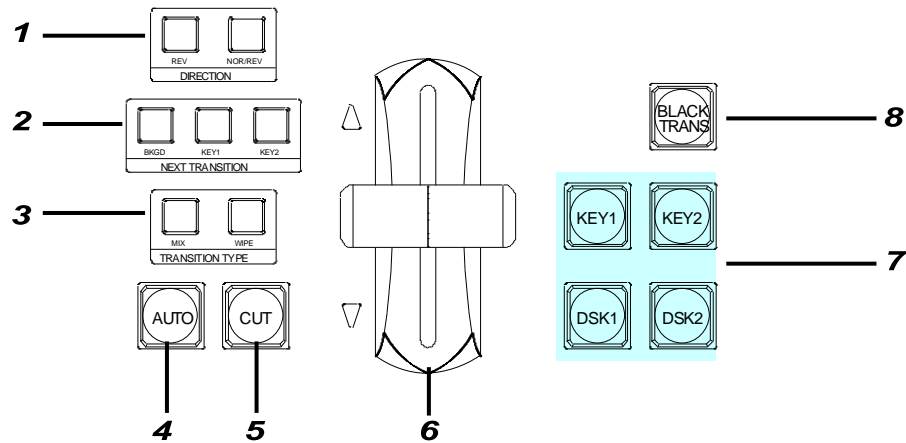

No.	Description
1	Pattern transition direction setting buttons
2	Next transition bus selection buttons
3	Transition type selection buttons for BKGD, KEY1 and KEY2
4	AUTO transition button for BKGD and KEY1 and KEY2
5	CUT transition button for BKGD and KEY1 and KEY2
6	Fader lever for performing BKGD, KEY1 and KEY2 transitions
7	KEY1, KEY2, DSK1 and DSK2 transition buttons
8	Black transition button

8-2. Quick Reference for Available Transitions

Bus	Type	Rate	Transition Limit	Pattern Direction	Transition Execute Button or Tool	Refer to
BLACK	BLACK	Available	-	-	BLACK TRANS button	8-6
BKGD	CUT	-	Available	-	BKGD >> CUT button	8-3
	MIX	Available	Available	-	BKGD >> MIX >> AUTO button	
		--	Available	-	BKGD >> MIX >> Fader lever	
	WIPE	Available	Available	NOR/REV	BKGD >> WIPE >> AUTO button	8-3
-		Available	NOR/REV	BKGD >> WIPE >> Fader lever	8-8	
KEY1 KEY2	CUT	-	Available	-	KEY >> CUT button KEY1 and KEY2 transition buttons	8-4
	MIX	Available	Available	-	KEY >> MIX >> AUTO (KEY1 and KEY2 transition buttons)	
		--	Available	NOR/REV	BKGD >> MIX >> Fader lever	
	WIPE	Available	Available	NOR/REV	KEY >> WIPE >> AUTO (KEY1 and KEY2 transition buttons)	8-4
		-	Available	NOR/REV	KEY >> WIPE >> Fader lever	8-8
	USER TRANS	Available	-	-	Function-assigned user buttons	8-10
PRIORITY	--	--	--	Function-assigned user button		
DSK1 DSK2	CUT	-	Available	-	DSK1 and DSK2 transition buttons	8-4
	MIX	Available	Available	-	DSK1 and DSK2 transition buttons	
	USER TRANS	Available	Available	-	Function-assigned user buttons	8-10
	PRIORITY	--	--	--	Function-assigned user button	

8-3. Background Transitions

This chapter explains how to perform background transitions.

CUT Transition

- (1) Select a video source in the PST bus block.
- (2) Press the **BKGD** button in the NEXT TRANSITION block.
- (3) Press **CUT** to perform the background CUT transition.

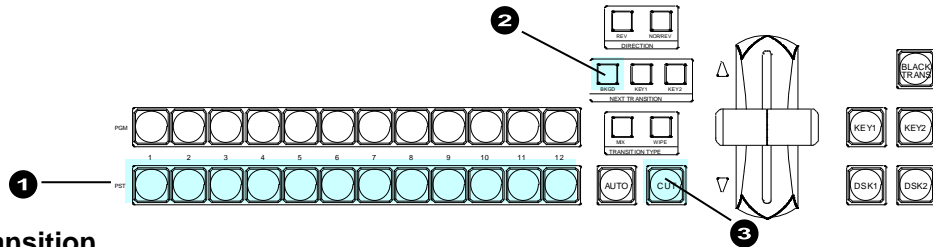

MIX Transition

- (1) Select a video source in the PST bus block.
- (2) Press the **BKGD** button in the NEXT TRANSITION block.
- (3) Press **MIX** in the TRANSITION TYPE block.
- (4) Press **AUTO** or move the fader lever to perform the background MIX transition.

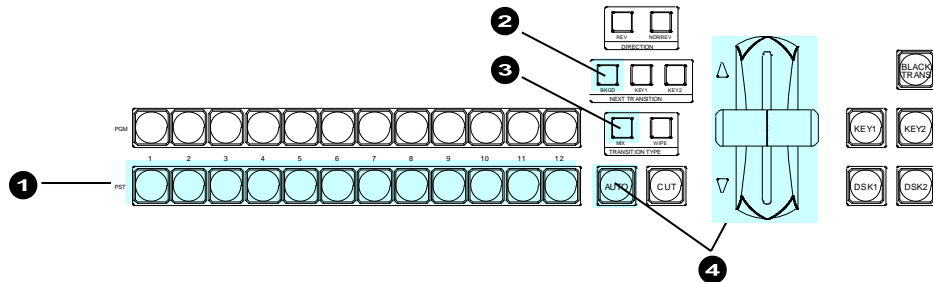

WIPE Transition

- (1) Select a video source in the PST bus block.
- (2) Press the **BKGD** button in the NEXT TRANSITION block.
- (3) Press **WIPE** in the TRANSITION TYPE block. The [TRANS] (1/6) menu is displayed.

If the light of the **WIPE** button does not turn on, a WIPE channel is already being used for KEY1 or KEY2. In such case, change the KEY1 or KEY2 type to MIX, then press the **WIPE** button again for the BKGD bus.

- (4) Turn **F4** to select a desired pattern. (MIX, FAM and NAM transition types can be also selected using Patterns 200 to 202.)
- (5) Press **AUTO** to perform the background WIPE transition.

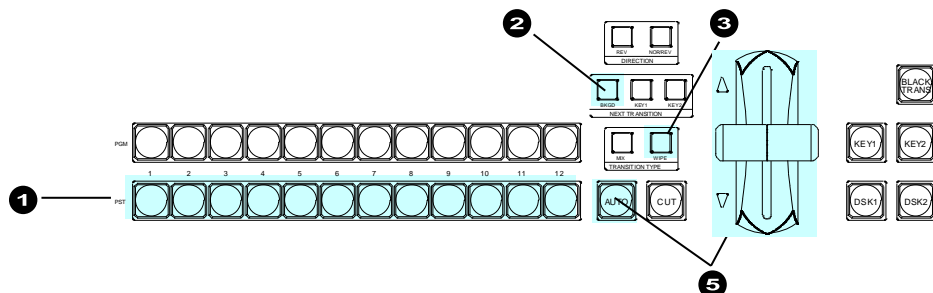

- ▶ See section 8-8. "Pattern (WIPE) Transitions" for the WIPE transition details.
- ▶ See section 8-11-2. "Transition Rate" for the transition rate.
- ▶ See section 8-11-3. "Transition Limit" for the transition limit.

To Check Next Video:

To check the Preview video, assign the Preview video to an AUX bus to display the image.

- ▶ See section 6-2. "Preview Set Up."

To check the clean video, assign the Clean video to an AUX bus to display the program video clear signal.

- ▶ See section 6-3. "Clean Set Up."

8-4. KEY Transitions

Key images are displayed on the M/E (background) output screen. This chapter explains how to perform key transitions using KEY1 as an example.

1. Perform key setup for KEY1.
 - ▶ See section 9. "KEY/DSK."
2. Perform a desired transition referring to the below procedures.

CUT Transition

- (1) Press **KEY1** in the NEXT TRANSITION block.
- (2) Press **CUT** to perform a key CUT transition. KEY1 will be inserted onto the program video. Press the button again to remove KEY1 from the screen.

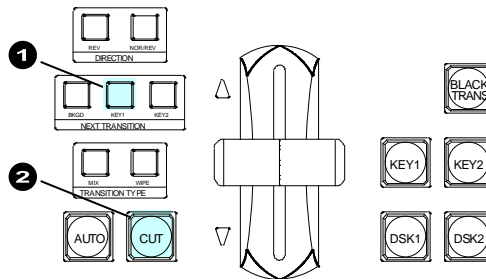

MIX Transition

- (1) Press **KEY1** in the NEXT TRANSITION block.
- (2) Press **MIX** in the TRANSITION TYPE block.
- (3) Press **AUTO** or **KEY1** or move the fader lever to perform the KEY1 MIX transition.

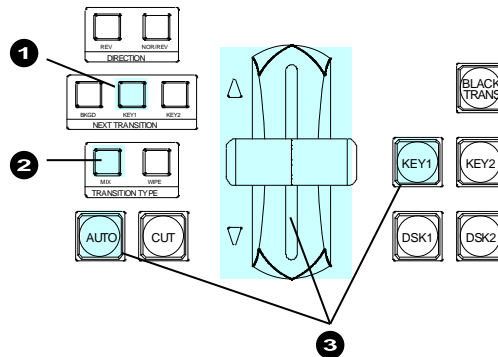

Pattern transition

- (1) Press **KEY1** in the NEXT TRANSITION block.
- (2) Press **WIPE** in the TRANSITION TYPE block. The [TRANS](1/6) menu is displayed.

If the light of the **WIPE** button does not turn on, a WIPE channel is already being used for BKGD or KEY2. In such case, change the BKGD or KEY2 type to MIX, then press the **WIPE** button again for KEY1.

- (3) Turn **F4** to select a desired pattern. (Note that only one pattern can be set at the same time.)

TRANS	: RATE	: TRANS LIMIT	: PAT NO	1/6
BKGD	: =30	: =100.0	: =OFF	→

(4) Press **AUTO** or **KEY1**, or move the fader lever to perform the pattern transition.

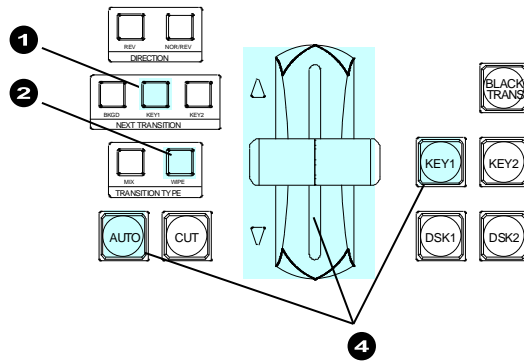

The **KEY1** transition button behaves the same as the **AUTO** button when selecting **KEY1** for the next transition. For example, if **MIX** is set as the **KEY1** transition type under the **NEXT TRANSITION**, the **KEY1** mix transition is performed when **KEY1** is pressed and a **KEY1** wipe transition is performed if **WIPE** is set as the transition type.

- ▶ See section 8-8. "Pattern (WIPE) Transitions" for details on WIPE transitions.
- ▶ See section 8-11-2. "Transition Rate" for details on the transition rate.
- ▶ See section 8-11-3. "Transition Limit" for details on the transition limit.

Note that when performing pattern transitions with a DVE pattern (No. 100 -137) for **KEY1** or **KEY2**, all 2D DVE menu settings are disabled.

- ▶ See section 9-8 "DVE Effect on KEY/DSK."

USER Transition

Press a user button, to which a **KEY1** effect transition (scaler, slide in/out, etc.) is assigned, to insert the **KEY1** image on the M/E program video.

- ▶ See section 8-10-2. "USER Transitions" for details.

8-5. DSK Transitions

DSK images are displayed on the M/E (background) or an AUX output screen. This chapter explains how to perform DSK transitions using DSK1 as an example.

▶ See section 8-5-1. "Where DSK Images Appear."

1. Perform key setup for the DSK1.
 - ▶ See section 9. "KEY/DSK."
2. Perform a desired transition referring to the below procedures.

MIX Transition

Press **DSK1**.

The transition rate can be set.

▶ See section 8-11-2. "Transition Rate."

CUT transitions are also available.

▶ See section 8-10. "KEY/DSK Transitions."

The **DSK1** button can also perform CUT transitions by changing the button function in the menu.

▶ See section 8-10-1. "Setting the KEY/DSK Transition Button Function."

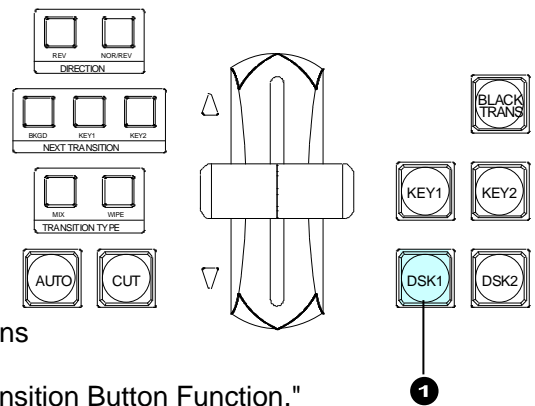

USER Transition

Press a user button, to which a DSK1 effect transition (scaler, slide in/out, etc.) is assigned, to insert the DSK1 image on the M/E program video.

▶ See section 8-10-2. "USER Transitions" for details.

8-5-1. Where DSK Images Appear

The DSK1 and DSK2 images appear on the program screen as a factory default setting. Users can change the destination of DSK images to an AUX bus. To do this, follow the procedure below.

- (1) Press **MENU**, then **SETUP** in the SELECT/KEYPAD block to display the [SETUP] menu.
- (2) Turn **F1** to select **FUNCTION**, and press **F1** to open the [SETUP - FUNCTION] menu.
- (3) Turn **F1** to select **M/E_KEY**, and press **F1** to open the [SETUP - FUNCTION - M/E KEY] menu.
- (4) To display the DSK1 image on the AUX1 program video, turn **F3** to select AUX1 and then press **F3**. Select the destination for DSK2 in the same way.

FUNCTION:TRSEGE:KEY LNK: DSK ASSIGN	: 1/1
M/E KEY : =ON : =ON : 1=AUX1 2=M/E	:

8-6. Simultaneous BKGD and Key Transitions

Background and key transitions can be performed simultaneously. This chapter explains how to perform simultaneous BKGD, KEY1 and KEY2 transitions as an example.

- (1) Set transition types for the background, KEY1 and KEY2 to MIX or WIPE, respectively. Select a pattern using the menu if set to WIPE.
- (2) Set the transition rate or direction, if necessary.
- (3) Press **BKGD**, **KEY1** and **KEY2** simultaneously to turn on the button lights.
- (4) Press **AUTO**, or move the fader lever to perform a simultaneous transition.

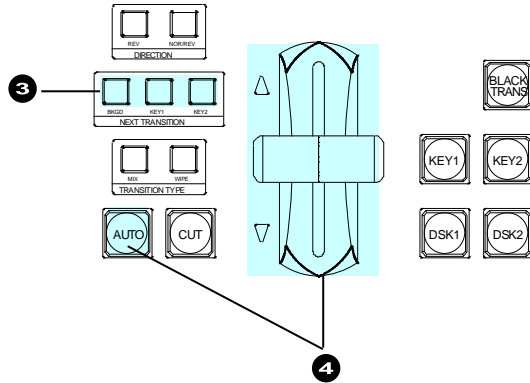

8-7. Black Transitions

Pressing the **BLACK TRANS** button allows BLACK transitions to be performed. Pressing the button initiates a fade to black of whichever source is currently on air (program output). Pressing the button again starts another fade from black to the previous video. BLACK transitions can be performed on the PGM output.

To Set the Black Transition Rate

- (1) Press **MENU** then **TRANSITION RATE** in the SELECT/KEYPAD block to display the [TRANS] menu.
- (2) Press the page down button to go to PAGE 6.
- (3) Turn **F1** to set the transition rate in frames for BLACK transitions.

TRANS	:	RATE	:	ENABLE	:		:	6/6
BLACK	:	=30	:	=ON	:		:	

To Disable the BLACK TRANS button:

Set the **ENABLE** item in the [TRANS] (6/6) menu above to **OFF**. (The default setting is **ON**.)

8-8. Pattern (WIPE/DVE) Transitions

Pattern transitions are available for Background, KEY1 and KEY2.

- ▶ See section 8-3. "Background Transitions."
- ▶ See section 8-4. "KEY Transitions."

This chapter explains details on the pattern selection method and transition direction.

8-8-1. Selecting a Pattern

- (1) Press **[WIPE]** in the transition block to display the [TRANS] (1/6) menu. The pattern number and thumbnail will be displayed as shown in the menus below.

TRANS	:	RATE	:	TRANS LIMIT	:	PAT NO	:		:	1/6
BKGD	:	=30	:	=100.0	:	=OFF	:	=0	:	

TRANS	:	RATE	:	TRANS LIMIT	:	PAT NO	:		:	1/6
BKGD	:	=30	:	=100.0	:	=OFF	:	= M20	:	

Numbers starting with the letter M :	Indicates modified patterns. ▶ See section 8-9. "Modifying Patterns."
Numbers starting with the letter C :	Indicates the pattern is being used by CG WIPE. ▶ See section 12-5. "CG WIPE."

- (2) Turn **[F4]** to select a pattern.

The Direct Pattern function allows users to select patterns quickly.

- ▶ See section 8-8-3. "Direct Pattern Function."

Available Patterns are:

There are two types of preset patterns: **WIPE** and **DVE**.

MIX, **FAM** or **NAM** can also be elected as pattern types.

Pattern No.	Type of Group	Available modification settings
0 to 99	WIPE	2D border, multi, 2D position, 2D size, etc. ▶ See "Appendix 2."
100 to 137	DVE (2D DVE)	2D border, 2D position, 2D size, crop, etc. ▶ See "Appendix 2."
200	MIX	Performs MIX transitions.
201	FAM	Performs Full-Additive Mix transitions.
202	NAM	Performs Non-Additive Mix transitions.

Only one pattern can be selected for all BKGD, KEY1 and KEY2 buses.

Note that if WIPE is set for a bus, WIPE cannot be set for another bus. In such case, cancel WIPE by selecting MIX for the current bus, then press the **[WIPE]** button again for the desired bus.

8-8-2. Use Limitations for Pattern Transitions

◆ **When using a WIPE type pattern (0-99):**

Pattern transitions cannot be simultaneously performed both on KEY1 and KEY2.

If both KEY1 and KEY2 pattern transitions are performed, one transition is automatically changed to MIX.

◆ **When using a DVE type pattern (100-137):**

Either BKGD, KEY1 or KEY2 bus can perform pattern transitions.

If the WIPE type cannot be set, a DVE pattern must be assigned to another bus. Deselect WIPE in another bus and set WIPE again for the bus.

Note that 2D DVE menu settings are all disabled while a pattern transition is being performed on KEY1 or KEY2.

▶ See section 9-8. "DVE Effects on KEY/DSK."

If 2D DVE is enabled on all four key buses, KEY1, KEY2, DSK1 and DSK2, BKGD pattern transitions cannot be performed. In such case, set 2D DVE to OFF on any bus. Then press WIPE again for BKGD.

▶ See section 9-8-1. "How to Enable 2D DVEs."

◆ **When using FAM (Pattern 201) or NAM (Pattern 202):**

FAM or NAM transitions cannot be performed on KEY1 and KEY2. If selecting Pattern 201 or 202 for a key, transitions are performed with MIX instead FAM or NAM.

8-8-3. Direct Pattern Function

The Direct Pattern Selection feature allows users to select a pattern easily and quickly. The feature uses the number buttons on the keypad (0-9), to which WIPE patterns previously registered can be recalled at the touch of a button. Up to 20 patterns can be registered as direct patterns under two pages (PAGE 0 and PAGE 1).

As an operational example, let's save Pattern 20 to the Direct Pattern memory and load it to a WIPE transition.

To Register Pattern 20 to Button 1 (PAGE 0):

- (1) Press **[WIPE]** in the transition block to display the [TRANS] (1/6) menu.
- (2) Turn **[F4]** to select **20**.

TRANS	:	RATE	:	TRANS LIMIT	:	PAT NO	:	20	:	1/6
BKGD	:	=30	:	=100.0	:	=OFF	:	=20	:	

Modify the pattern, if necessary.

▶ See section 8-9 "Modifying Patterns."

- (3) Press **[DIRECT PATT]** on the left side of the SELECT/KEYPAD block to display the [DIRECT PATTERN] menu. The keypad also changes to DIRECT PATTERN mode.
- (4) Turn **[F1]** to select PAGE 0, if it is not selected.

DIRECT	:	PAGE	:	DIRECT	:	CLEAR	:		:	1/1
PATTERN	:	=0	:	=ON	:	>OFF	:		:	

- (5) Press **[STORE]** in the Keypad.
- (6) Press **[1]** in the Keypad.

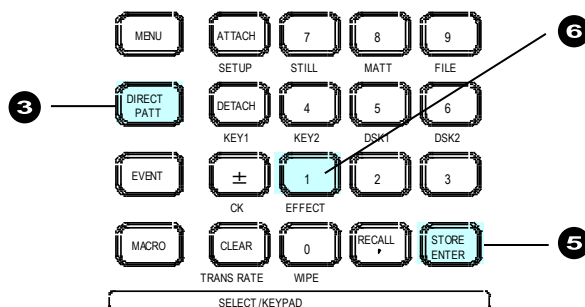

If a Pattern is already Saved to Button 1:

If Button **[1]** is lit in the keypad when pressing the **[DIRECT PATT]** button, another pattern has already been saved to the button. Press **[1]**. The button will blink. To overwrite the current pattern with Pattern 20, press **[1]** again. To cancel the overwrite, press **[STORE]**. To save to another button, press an unregistered button.

If users cannot overwrite a number button (lit red), cancel the operation and change the **OVER WR** (overwrite) parameter from **DISBL** (disable) to **ENABL** (enable) in the [DIRECT RECALL] menu. The [DIRECT RECALL] menu is automatically displayed when the number button to which a pattern is stored on the keypad is pressed.

To Select Pattern 20:

- (1) Press **DIRECT PATT** to change the keypad to DIRECT PATTERN mode.
- (2) Press **1** on the Keypad. Pattern 20 will be selected and the transition type is automatically switched to WIPE.

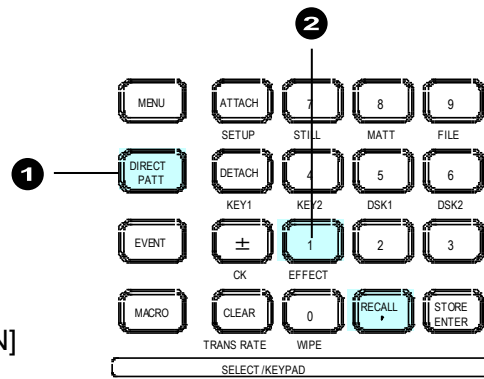

If Pattern 20 is not selected...

Press **RECALL** on the keypad after pressing **1**. If **DIRECT** is set to **ON** in the [DIRECT PATTERN] menu by turning **F2**, **Direct Recall** mode is enabled and patterns can be recalled by pressing number buttons (without pressing **RECALL**.)

If another pattern is selected...

PAGE 1 is assumed to be selected.

Select **PAGE 0** in the [DIRECT PATTERN] menu by turning **F1**.

DIRECT	:	PAGE	:	DIRECT	:	CLEAR	:		:	1/1
PATTERN	:	=0	:	=ON	:	>OFF	:		:	

To Set Overwrite Protection or Delete the Data

- (1) Press **DIRECT PATT** to change the keypad mode.
- (2) Verify that PAGE0 is selected.
- (3) Press **1** on the Keypad. The [DIRECT RECALL] menu will be displayed.
- (4) Turn **F3** to change **OVER WR** (Overwrite) to **DISBL** (Disable) to set overwrite protection.

DIRECT	:	PATTERN		↑	:	OVER WR:DELETE	:	1/1
RECALL	:	=020		↓	:	=DISBL:	>OFF	:

Turn **F4** to set DELETE to **ON** and then press **F4**. The data will be deleted from the button.

DIRECT	:	PATTERN		↑	:	OVER WR:DELETE	:	1/1
RECALL	:	=020		↓	:	=ENABL:	>ON	:

In the procedure above, Pattern 20 is recalled when **1** is pressed. To prevent the pattern, from being recalled, set **DIRECT** to **OFF** in the menu before recalling the event, then press the number button.

To Clear All Direct Pattern Registrations

- (1) Press **DIRECT PATT** to change the keypad mode.
- (2) Turn **F3** to change **CLEAR** to **ALL**. Then press **F3** to clear all direct patterns.

DIRECT	:	PAGE	:	DIRECT	:	CLEAR	:		:	1/1
PATTERN	:	=0	:	=OFF	:	>ALL	:		:	

8-8-4. Other Transition Settings

Transition Direction

Two direction buttons (NOR/REV, REVERSE) are used to set the pattern transition direction as shown in the table below.

Transition direction	NOR/REV button	REV button
Always Normal	Unlit	Unlit
Always Reverse	Unlit	Lit
Normal at Normal/Reverse operation	Lit	Unlit
Reverse at Normal/Reverse operation	Lit	Lit

Transition Rate

The AUTO transition duration (Transition Rate) can be set in the menu.

▶ See section 8-11-2. "Transition Rate."

Transition Limit

When performing transitions there may be times when you want the transition to the next signal to only complete to a certain degree instead of fully switching from one picture to another. In such case, change the Transition Limit setting in the menu.

▶ See section 8-11-3. "Transition Limit."

8-9. Modifying Patterns

Preset patterns can be modified using the WIPE menu. Two pattern types are available: WIPE and DVE. Each type has its own menu pages.

Pattern No.	Type of Group	Available modification settings
0 to 99	WIPE	2D border, multi, 2D position, 2D size, etc.
100 to 137	DVE (2D DVE)	2D border, 2D position, 2D size, crop, etc.

If a pattern is modified, the pattern number starts with the letter "M" in the [TRANS](1/6) menu as shown below.

TRANS	:	RATE	:	TRANS LIMIT	:	PAT NO	:	1/6
BKGD	:	=30	:	=100.0	:	=OFF	:	=M0

The following chapters explain how to modify patterns using the background and KEY1 as examples.

8-9-1. WIPE Type (No. 0-99)

◆ WIPE menu

The pattern number is displayed instead of "0XX" in the top page of the submenu.

WIPE	:	>BORDER	>POS/ANGL	>MULTI	>CG WIPE
No. 0XX	:	>INIT			

WIPE	:	SIGNAL	:	WIDTH	:	SOFT	:	1/2
BORDER	:	=MATT	:	=0.0	:	=0.0	:	:

WIPE	:	BORDER COLOR	:	RECALL	:	2/2
BORDER	:	S=66.3	L=5.4	H=3.5	:	>WHITE:

WIPE	:	POSITION	:	ANGLE	:	ASPECT	:	1/1
POS/ANGL	:	X=0	Y=0	:	=0.0	:	=0.0	:

WIPE	:	MULTI	:	1/1	
MULTI	:	X=1	Y=1	:	:

WIPE	:	INIT	:	1/1
INIT	:	>OFF	:	:

► See section 12-5-3. "CG WIPE Menu Quick Reference" for details on CG WIPE pages.

◆ **Modify Pattern 20**

This modification example adds a border to the background transitions using Pattern 20.

- (1) Select a desired signal on the PST bus.
- (2) Press **BKGD** in the NEXT TRANSITION block.
- (3) Press **WIPE**. The [TRANS] (1/6) menu is displayed.
- (4) Press **F4** to enter 20 in the keypad, then press **ENTER**.

TRANS	:	RATE	:	TRANS LIMIT	:	PAT NO	:	<input type="text" value="20"/>	:	1/6
BKGD	:	=30	:	=100.0	:	=OFF	:	= 20	:	

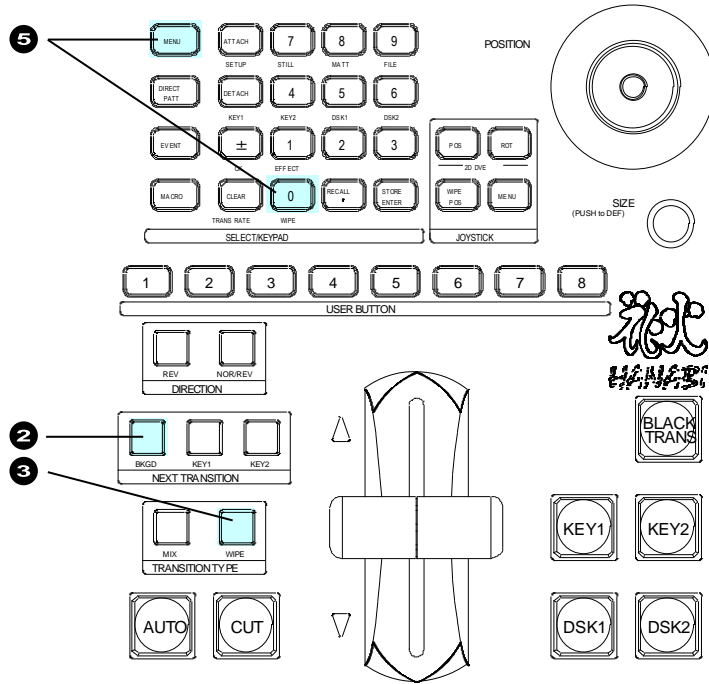

- (5) Press **MENU**, then **WIPE** in the SELECT/KEYPAD block to display the [WIPE] menu.
- (6) Turn **F1** to select **BORDER**, then press **F1** or the page down button to display the submenu.

WIPE	:	> BORDER	>POS/ANGL>MULTI	>CG WIPE
No.020	:	>INIT		

- (7) The [WIPE - BORDER] menu appears. Turn **F1** to select the signal used for the border under **SIGNAL**. Select **MATT** in this example. Set the border width under **WIDTH** and border softness under **SOFT**.

WIPE	:	SIGNAL	:	WIDTH	:	SOFT	:		:	1/2
BORDER	:	= MATT	:	=5.0	:	=2.0	:		:	

- (8) Press the page down button to go to PAGE 2.
- (9) Turn **F4** to select a border color among eight standard colors.
 - ▶ See section 5-9-1. "Setting the Matte Color" for details on color setting.

Modified pattern data is lost when the switcher is powered off. In addition, any modified data is fully or partly lost when another pattern is selected. It is recommended that important modified patterns be registered to Direct Patterns.

To Register the Modified Pattern to a Direct Pattern:

- ▶ Refer to section 8-8-3. "Direct Pattern Function" to save a modified pattern to a direct pattern.

To Reset the Modified Pattern:

- (1) Press **[WIPE]** in the transition block to display the [TRANS] (1/6) menu. The letter "M" (Modified) will be displayed in front of 20.

TRANS	:	RATE	:	TRANS LIMIT	:	PAT NO	:	<input type="text" value="M20"/>	:	1/6
BKGD	:	=30	:	=100.0	:	=OFF	:	=	:	

- (2) Press and hold down **[F4]**. Pattern 20 will be reset to its default settings.

8-9-2. DVE Type (No. 100-137)

◆ **WIPE menu**

The pattern number is displayed instead of "1XX" in the top page of the submenu.

WIPE	:	>BORDER	>	POS/ASP	>	CROP	>	CG WIPE
No. 1XX	:	>INIT						

WIPE	:	INSIDE	:	OUTSIDE	:	1/3
BORDER	:	X=0	Y=0	X=0	Y=0	:

WIPE	:	INSIDE	:	OUTSIDE:	:	2/3
BDR SOFT	:	X=0	Y=0	=0	:	:

WIPE	:	BORDER COLOR	:	RECALL	:	3/3
BDR COL	:	S=0.0	L=100.0	H=0.0	:	>WHITE:

WIPE	:	POSITION	:	SIZE	:	1/2
POS/SIZE	:	X=0	Y=0	=1000	:	:

WIPE	:	ASPECT	:	FADE LV:	:	2/2
ASPT/FAD	:	X=1000	Y=1000	=0.0	:	:

WIPE	:	CROP POSITION	:	1/1		
CROP	:	T=0.0	B=0.0	L=0.0	R=0.0	:

WIPE	:	INIT	:	1/1
INIT	:	>OFF	:	:

- ▶ See section 12-5-3 "CG WIPE Menu Quick Reference" for details on CG WIPE pages.

◆ **Modify Pattern 117**

This modification example also adds a border effect to KEY1 transitions using Pattern 117. However Pattern 117 has different border settings than Pattern 20, and can be used for both inside and outside border effects.



(1) Set up KEY1.

▶ See section 9. "KEY/DSK."

(2) Press **KEY1** in the NEXT TRANSITION block.

(3) Press **WIPE**. The [TRANS](1/6) menu is displayed.

(4) Press **F4**, enter **117** and press **ENTER** in the Keypad.

TRANS	:	RATE	:	TRANS LIMIT	:	PAT NO	:		1/6
BKGD	:	=30	:	=100.0	:	=OFF	:		
	:		:		:	=	:		117

(5) Press **MENU**, then **WIPE** in the SELECT/KEYPAD block to display the [WIPE] menu. Select **BORDER**. Press **F1** or the page down button.

(6) An inside border is added in this example. To add a border, set the border width under **INSIDE X** and **Y**.

WIPE	:	INSIDE	:	OUTSIDE	:	1/3
BORDER	:	X= 20	Y= 50	X=0	Y=0	:

(7) Press the page down button to go to PAGE 2. Set the softness for the inside border under **INSIDE X** and **Y**.

WIPE	:	INSIDE	:	OUTSIDE:	:	2/3
BDR SOFT	:	X= 3	Y= 3	: =0	:	:

(8) Press the page down button to go to PAGE 3 and set the border color.

▶ See section 5-9-1. "Setting the Matte Color."

To Register the Modified Pattern to a Direct Pattern:

▶ Refer to section 8-8-3. "Direct Pattern Function" to save the modified pattern to a direct pattern.

To Fully or Partly Reset the Modified Pattern:

The **INIT** parameter allows the user to reset a submenu respectively in the WIPE menu.

(1) Display the [WIPE - INIT] menu.

(2) Turn **F1** to select the parameter group you want to reset. Press and hold down **F1** to reset the selected parameter values.

WIPE	:	INIT	:	:	1/1
INIT	:	> BORDER	:	:	:

8-10. KEY/DSK Transitions

KEY1 and KEY2 transitions can be performed not only through the BKGD AUTO button and fader lever, but also through key transition buttons (**KEY1** and **KEY2** in the transition section) and user buttons, to which key transition functions are assigned.

DSK1 and DSK2 transitions can be performed through DSK transition buttons (**DSK1** and **DSK2** in the transition section) and user buttons, to which DSK transition functions are assigned.

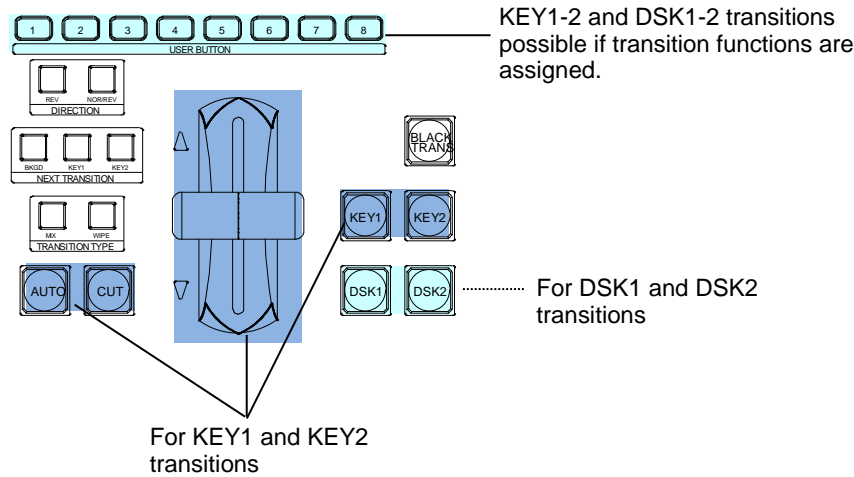

KEY1 and **KEY2** transition buttons can perform **CUT** and **AUTO (MIX and WIPE)** transitions.

DSK1 and **DSK2** transition buttons can perform **CUT** and **MIX** transitions.

Key or DSK transitions such as **CUT**, **MIX**, **SCALER**, **SLIDE** (4 types) and **WIPE** (4 types) can be assigned to user buttons.

◆ **KEY1**, **KEY2**, **DSK1** and **DSK2** Transition Button Light Indications

The transition buttons turn on while On-Air and turn off when Off-Air.

The light-up color of DSK buttons indicates the output destination (M/E or AUX bus).

Transition state	Output bus	Transition button indication
On-Air	M/E	Lit red
On-Air (DSK1-2)	AUX1-8	Lit green
Transition	---	Flashing
Off-Air	---	Unlit

8-10-1. Setting the KEY/DSK Transition Button Function

Transition button functions for **KEY1**, **KEY2**, **DSK1** and **DSK2** are set in the menu as shown below.

- (1) Press **MENU**, then **TRANS RATE** in the SELECT/KEYPAD block to display the [TRANS] (1/6) menu.
- (2) Press the page down button to go to PAGE 2 in case of KEY1.
- (3) Turn **F2** to select **AUTO** or **C/AT**.

TRANS	: RATE	: ADV CTL:	TRANS LIMIT	: 2/6
KEY1	: =30	: = AUTO	: =100.0En=OFF	:

The buttons are set to **AUTO** as factory default. The transition buttons function as shown in the table below.

Parameter	Setting	Description	
ADV CTL	AUTO (default)	KEY1 KEY2	Always performs AUTO transitions regardless of how long the button is pressed.
		DSK1 DSK2	Always performs MIX transitions regardless of how long the button is pressed.
	C/AT	KEY1 KEY2	Performs Cut transitions when button is briefly pressed. Performs AUTO transitions when button is pressed and held down.
		DSK1 DSK2	Performs Cut transitions when button is briefly pressed. Performs MIX transitions when button is pressed and held down.
	OFF	Disables the button function.	

The transition time can be set under **RATE** in each [TRANS] menu.

► See section 8-11-2. "Transition Rate" for details.

Note that users can perform key transitions by pressing **AUTO** as well as **KEY1** or **KEY2**.

► See section 8-4. "KEY Transitions."

8-10-2. USER Transitions

The Key and DSK transition functions can be assigned to user buttons. This chapter explains how to assign functions to buttons by assigning **DSK1 SCALER** to **USER BUTTON 3** as an example.

- (1) Press **MENU**, then **SETUP** in the SELECT/KEYPAD block to display the menu.
- (2) Turn **F1** to select **PANEL**, then press **F1** to display the [SETUP - PANEL] menu.
- (3) Turn **F1** to select **USER BTN**, then press **F1** to display [SETUP - PANEL - USER BUTTON] (1/2) menu.
- (4) Turn **F1** to select **OU-3 (USER BUTTON 3)**.
- (5) Turn **F2** to select **USTRS (User Transition)**, then press **F2**.
- (6) Turn **F3** to select **DSK1 SCALER**, then press **F3**.

USER	: SELECT	: TYPE	: FUNC(F3)	: 1/2
BUTTON	: =OU-3	: =USTRS:	=DSK1 SCALER	

- (7) Press **USER BUTTON 3** to perform the DSK1 transition.

Avilable User Transitions

TYPE Setting	FUNC Setting	Description
USTRS (User Transition)	CUT	Cuts images in or out.
	SCALER	Scales up to insert images or scales down to remove images.
	SLIDE RIGHT/LEFT	Slides in to insert images or slides out to remove images.
	SLIDE TOP/BOTTOM	
	WIPE RIGHT/LEFT	Wipes images in or out.
	WIPE TOP/BOTTOM	

► See section 14. "User Buttons."

8-11. Transition Settings

8-11-1. TRANS Menu

To display the [TRANS] menu, press **[MENU]**, then **[TRANS RATE]** in the SELECT/KEYPAD block. The [TRANS] menu consists of six pages for each bus. Use the page down or up button to move between pages.

Parameter	Description	Refer to sec.
RATE	Sets the transition rate for each bus.	8-11-2
TRANS LINIT	Sets the transition limit for each bus.	8-11-3
ADV CTL	Sets the transition function for the KEY1, KEY2, DSK1 and DSK2 transition buttons (to the right side of the fader)	8-10-1
PAT NO (PAGE 1)	Selects a pattern for the BKGD, KEY1 and KEY2 pattern transitions.	8-8-1
ENABLE (PAGE 6)	Enables/Disables the BLACK TRANSITION button.	8-7

Pressing the following buttons in the transition block can also open the related TRANS menu page.

BKGD, KEY1, KEY2 (NEXT TRANSITION buttons on the left side of the fader)
MIX, WIPE (TRANSITION TYPE buttons)

TRANS	: RATE	: TRANS LIMIT	: PAT NO	<input type="text" value="0"/>	: 1/6
BKGD	: =30	: =100.0	=OFF	: =0	:

TRANS	: RATE	: ADV CTL	: TRANS LIMIT	: 2/6
KEY1	: =30	: =AUTO	: =100.0En=OFF	:

TRANS	: RATE	: ADV CTL	: TRANS LIMIT	: 3/6
KEY2	: =30	: =AUTO	: =100.0En=OFF	:

TRANS	: RATE	: ADV CTL	: TRANS LIMIT	: 4/6
DSK1	: =30	: =AUTO	: =100.0En=OFF	:

TRANS	: RATE	: ADV CTL	: TRANS LIMIT	: 5/6
DSK2	: =30	: =AUTO	: =100.0En=OFF	:

TRANS	: RATE	: ENABLE	:	: 6/6
BLACK	: =30	: =ON	:	:

8-11-2. Transition Rate

The transition rate setting determines how long the transition takes in frames to complete.

- (1) Open the desired [TRANS] menu page.
- (2) Turn **[F1]** to set the transition rate. To enter the rate in the KEYPAD, press **[F1]**, enter the rate using the keypad, then press **[ENTER]** in the keypad to store the new transition rate. The setting range is 0 to 999 on a frame basis.

8-11-3. Transition Limit

The Transition Limit setting determines how far your transition can proceed. When performing transitions (mix or other) there may be times when you want the transition to the next signal to only complete to a certain degree instead of fully switching from one picture to another.

To perform **background transitions that do not fully switch pictures**, proceed as follows.

(2) Turn **F2** to set to **90.0**. Turn **F3** to set to **ON** under **TRANS LIMIT**.

```

TRANS   : RATE   :TRANS LIMIT :PAT NO ████ : 1/6
BKGD    : =30    :=90.0  =ON   : =0    → :
    
```

(3) Let's perform background MIX or WIPE transitions by pressing **AUTO** or moving the fader lever. The transition must be completed before the background pictures are fully switched.

The default settings are **100.0** and **OFF**. With this setting, the transition is complete with fully switching pictures.

In the following menu pages, the transition limit for KEY1-2 and DSK1-2 can be set in the same way

8-11-4. Adjusting the Fader Offset

The fader offset range can also be adjusted in the [SETUP - PANEL - TRS CTRL] menu. Turn **F3** and **F4** to adjust the fader **OFFSET**.

```

PANEL   :BUSTYPE:          : FADER OFFSET : 1/1
M/E CTRL: =P/P   :          : U=1.00  L=1.00 :
    
```

Parameter		Description
FADER OFFSET	U	Sets the upper edge offset.
	L	Sets the bottom edge offset.

8-11-5. Endpoint Processing for DVE Transitions

In DVE operations, differences in video delay times when entering and exiting DVE effects can cause the video to appear choppy. This choppiness can be reduced by menu setting so that the DVE effect always exits at the transition start and end points (**TRS EDGE** to **OFF** in the [SETUP - FUNCTION - M/E_KEY] menu).

```

FUNCTION:TRSEGE:KEY LNK:  DSK ASSIGN : 1/1
M/E KEY : =OFF  : =ON   : 1=M/E  2=M/E :
    
```

9. KEY/DSK

The key feature enables you to superimpose titles and images onto background signals. With the switcher, four key channels are provided: KEY1-2 and DSK1-2. Three key types are available in all keyers: Luminance Key, Full Key and Bus Key. Key Invert, Mask and 2D DVE effects can also be added to keys. Furthermore, Edge effects can be used in KEY1 and KEY2.

KEY1, KEY2, DSK1 and DSK2 Features

Feature	KEY1 and KEY2	KEY3 and KEY4	Refer to
Luminance key	Available	Available	9-1
Full key	Available	Available	9-2
Bus key	Available	Available	9-3
Key invert	Available	Available	9-6-1
Box mask, signal mask	Available	Available	9-6-2
Preset mask	Available	-	9-6-2
Edge effect	Available	-	9-7
Pattern transition	Available	-	8-8
2D DVE	Available	Available	9-8
IN/OUT effects	Available	Available	8-10
AUX output	-	Available	8-5-1

The following section describes key setup and adjustment using KEY1 as an example.

◆ Luminance Key

Luminance Key, also called Self Key, uses the same image for Key Source and Key Insert. This image is selected from Key Insert.

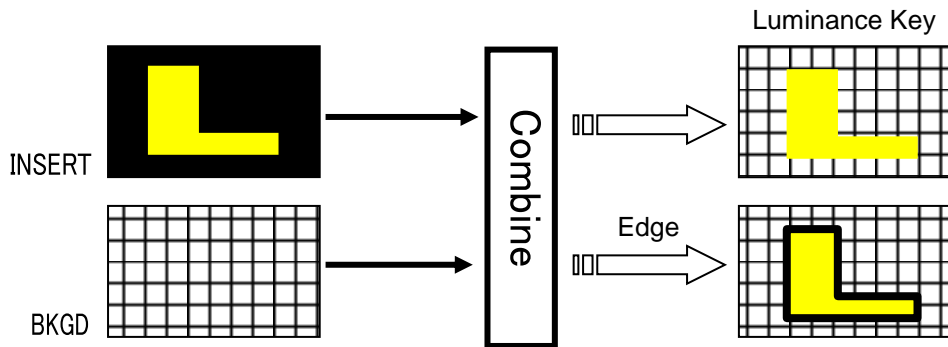

◆ Full Key

Full Key displays the key insert signal full-screen.

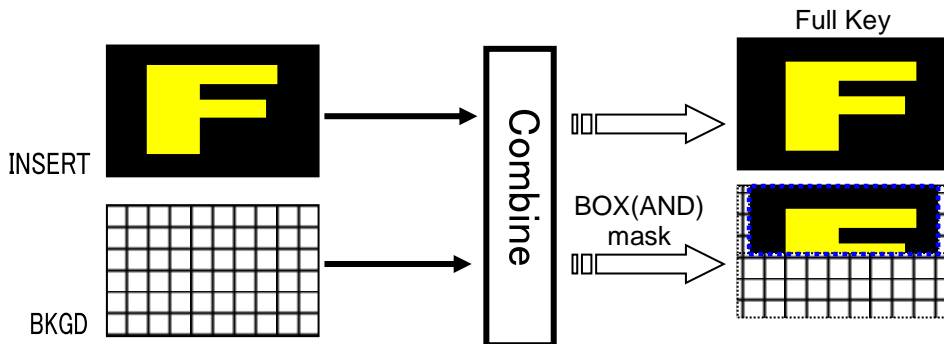

◆ **Bus Key**

Bus Key, also called External Key, uses different images for Key Source and Key Insert. The background signal is cut out using Key Source and Key Insert fills in the cut-out part of the signal.

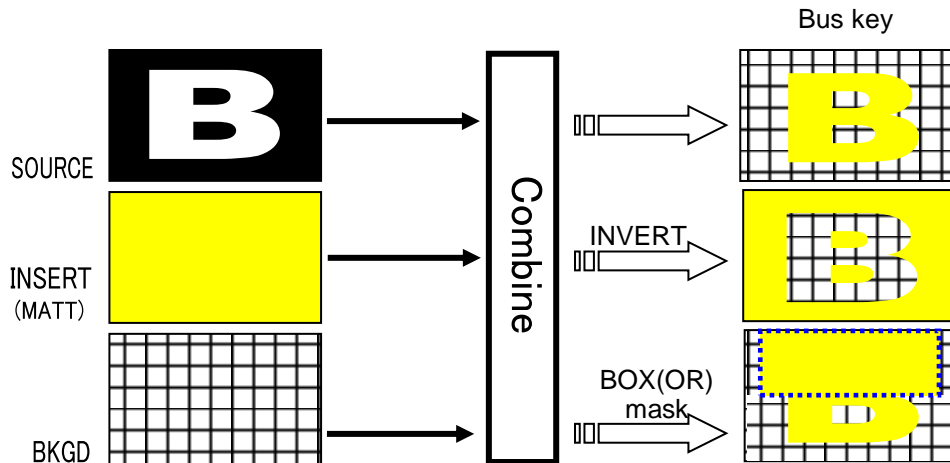

9-1. Creating a Luminance Key

- (1) Press the **KEY1** transition button in the bottom right corner of the control panel to display KEY1 on the PGM video.
- (2) Press **KEY1** above the KEY/AUX bus.
- (3) Select a signal for Key Insert in the KEY/AUX bus.

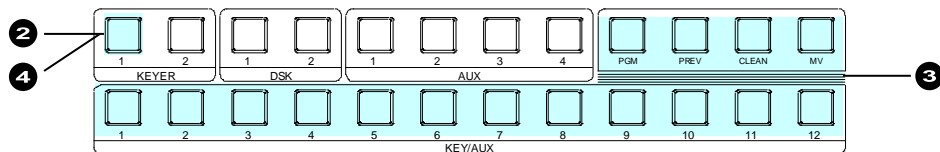

- (4) Double-press **KEY1** above the KEY/AUX bus to display the [KEY1 SETUP] menu.
- (5) Turn **F1** to select **INS/SRC**, and press **F1** or the page down button.

KEY1	:	INS/SRC	>EDGE	>MASK
SETUP	:	>POS/SIZ	>BORDER	>INIT

- (6) The [KEY1 - INS/SRC] menu is displayed. Turn **F1** to set **TYPE** to **LUM**. The insert signal can also be selected at INSERT.

KEY1	:	TYPE	:	INSERT	:	SOURCE	:	INVERT	:	1/4
INS/SRC	:	LUM	:	=IN01	:	=IN01	:	=OFF	:	

KEY1 will cover the entire screen. To decrease the KEY1 size, use the 2D DVE feature. (See section 9-8. "DVE Effects on KEY/DSK.")

- ▶ See section 8-4. "KEY Transitions" and 8-10. "KEY/DSK IN/OUT Effects" for details on transitions.
- ▶ See section 9-4. "Adjusting Key Signal" for details on making fine adjustments. Edge (KEY1 and 2 only), Invert, Mask and 2D DVE effects can be applied to Luminance keys.

9-2. Creating a Full Key

- (1) Follow Step (1) to (5) in "Luminance Key" above.
- (2) The [KEY1 - INS/SRC] menu is displayed. Turn **F1** to set **TYPE** to **FULL**. The insert signal can also be selected at **INSERT**.

KEY1	:	TYPE	:	INSERT	:	SOURCE	:	INVERT	:	1/4
INS/SRC	:	= FULL	:	=IN01	:	=IN01	:	=OFF	:	

9-3. Creating a Bus Key

Bus Key uses different signals for Key Insert and Key Source. To create a Bus Key, select a Key Insert signal and a Key Source signal in the menus. Since selecting a signal in the menu takes time, the switcher has a KEY LINK function, which enables you to select a key source and insert using only a source button.

- ▶ See section 9-3-1. "Key Link" for details.

- (1) Press the **KEY1** transition button in the bottom right corner of the control panel to display KEY1 on the PGM video.
- (2) Press **KEY1** above the KEY/AUX bus.
- (3) Select a signal for Key Insert in the KEY/AUX bus.

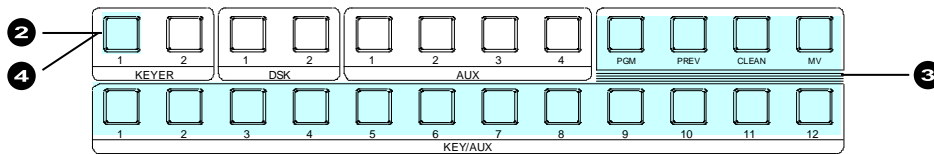

- (4) Double-press **KEY1** above the KEY/AUX bus to display the [KEY1 SETUP] menu.
- (5) Turn **F1** to select **INS/SRC**, and press **F1** or the page down button.

KEY1	:	> INS/SRC	>EDGE	>MASK
SETUP	:	>POS/SIZ	>BORDER	>INIT

- (6) The [KEY1 - INS/SRC] menu is displayed. Turn **F1** to set **TYPE** to **BUS**.
- (7) Turn **F3** to select a signal for Key Source in **SOURCE**.

KEY1	:	TYPE	:	INSERT	:	SOURCE	:	INVERT	:	1/4
INS/SRC	:	= BUS	:	=IN01	:	= IN02	:	=OFF	:	

KEY1 will cover the entire screen. To decrease the KEY1 size, use the 2D DVE feature. (See section 9-8. "DVE Effects on KEY/DSK.")

- ▶ See section 8-4. "KEY Transitions" and 8-10. "KEY/DSK IN/OUT Effects" for details on transitions.
- ▶ See section 9-4. "Adjusting Key Signal" for details on making fine adjustments. Edge (KEY1 and 2 only), Invert, Mask and 2D DVE effects can be applied to Luminance keys.

9-3-1. Key Link

A Key Source signal can be selected concurrently when a Key Insert signal is selected if KEY LINK is on. The INSERT/SOURCE signal pairs for Bus keys are automatically set once they are selected for a key. To change signal assignment, select the INSERT/SOURCE signal pair again for the key or another key. The same assignments are shared among all keys of KEY1-2 and DSK1-2.

When Using the Key Link:

- (1) Select a key among KEY1-2 and DSK1-2.
- (2) Select a signal for KEY INSERT in the KEY/AUX. This allows users to set a key signal pair: KEY INSERT and KEY SOURCE signals.

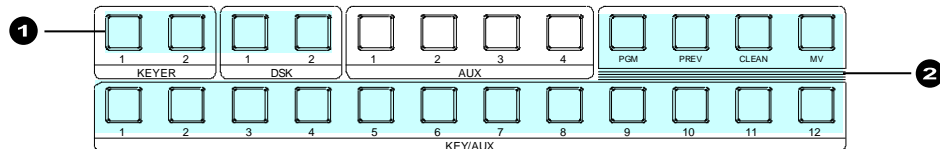

NOTE

If key links do not work properly, set **LINK** to **ON** in the [SETUP- FUNCTION - M/E_KEY] menu.

9-3-2. KEY INSERT MATT

In addition to the bus matt signal, the internally generated MATT can be used as key fill.

KEY INSERT MATT is a dedicated matte signal for keys and it is not the same as BUS MATT. The different colors can be set in KEY INSERT MATT for each key.

- (1) Set up a Bus Key, then press **F2** in the [KEY1 - INS/SRC] menu to set **INSERT** to **InMAT** (Insert Matt).

<pre>KEY1 : TYPE :INSERT :SOURCE :INVERT : 1/4 INS/SRC : =BUS : >InMAT: =IN02 : =OFF :</pre>

- (2) Press the page down button to go to PAGE 4.
- (3) Turn **F4** and select a color among eight standard colors, then press **F4**.
To use a different color, turn **F1**, **F2**, and **F3** to adjust the color.
▶ See section 5-9-1. "Setting the Matte Color."

<pre>KEY1 : MATT COLOR :RECALL : 4/4 INS MATT :S=67.3 L=15.8 H=257.5: >RED :</pre>
--

Key Links cannot be applied to KEY MATT.

9-4. Adjusting the Key Signal

Clip and Gain allows users to adjust the key signal and its composition over the background. KEY transparency can also be adjusted.

- (1) Double-press **KEY1** above the KEY/AUX bus to display the [KEY1 SETUP] menu.
- (2) Turn **F1** to select **INS/SRC**, and press **F1** or the page down button.
- (3) The [KEY1 - INS/SRC] menu is displayed. Press the page down button to go to PAGE2.

KEY1	:	GAIN	:	CLIP	:	TRANSP	:	FAM	:	2/4
ADJUST	:	=1.0	:	=6.2	:	=0.0	:	=OFF	:	

- (4) Turn **F1** to adjust **GAIN**
- (5) Turn **F2** to adjust **CLIP** for adjusting the key.
- (6) Turn **F3** to set the level of key transparency. Increasing the value makes the key more transparent.

Clip thresholds of key signals can be set for Bus and Luminance keys.

- (7) Go to PAGE 3.
- (8) Set key luminance thresholds levels under **CLIP-H** and **CLIP-L**. Turn **F3** to **ON** to enable these limits.

KEY1	:	CLIP-H	:	CLIP-L	:	ENABLE	:		:	3/4
KEY CLIP:	:	=100.0	:	=0.0	:	=ON	:		:	

◆ Clip Example

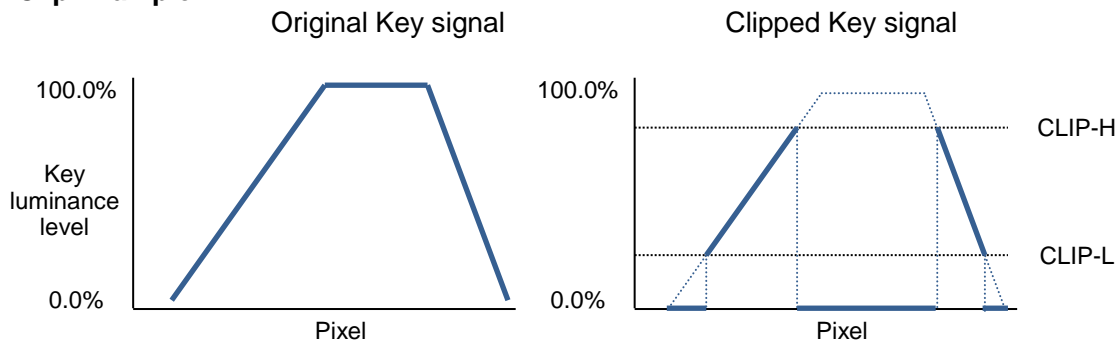

9-5. Changing KEY or DSK Layer Order

Layer order between KEY1 and KEY2, and DSK1 and DSK2 can be changed using a USER button. Assign **KEY1/2PRIORITY** or **DSK1/2PRIORITY** (TYPE: **KEYER**) to a USER button.

► See section 14. "USER Buttons."

Press the USER button, to which **KEY1/2PRIORITY** is assigned. KEY1 appears in front of KEY2.



The DSK layer order can be changed in the same way as that of KEY order. Also note that two DSK layers are always placed in front of two KEY layers.

9-6. Mask and Invert

Mask and Invert can be used for all keys. Preset masks are available only for KEY1 and KEY2.

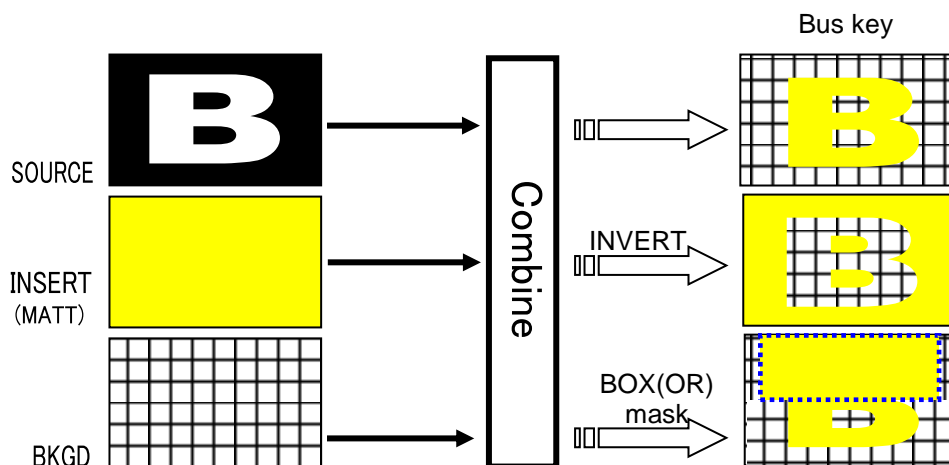

9-6-1. Inverting Key and Background

Setting Invert to ON inverts the key image and the background image. Set **INVERT** in the [KEY1 - INS/SRC] menu to ON. The key signal is then inverted.

9-6-2. Key Masks

◆ BOX Mask

Box-shaped masks can be applied to keys. They can also be inverted so that the keyed area inside the box becomes invisible.

- (1) Create KEY1.
- (2) Double-press **KEY1** above the KEY/AUX block to display the [KEY1 SETUP] menu.
- (3) Turn **F1** to select **MASK**, and press **F1** or the page down button to open the [KEY1 - MASK] menu.
- (4) Turn **F2** to set **BOX MASK** to **ON** in PAGE 1 of the [KEY1 - MASK] menu.
- (5) Set **TYPE** to **AND** or **OR**. If set to **AND**, the area where Key Source and Box Mask overlap is used as the key signal. If set to **OR**, both Key Source and Box Mask are used as the key signal.

KEY1	:	TYPE	:	BOX MSK	:	MASK (EXT/PST)	:	1/5
MASK	:	= AND	:	= ON	:	S=OFF	:	INV=OFF:

- (6) Set the horizontal and vertical mask width on PAGE 2 in the MASK menu.

KEY1	:	BOX MASK POSITION	:	2/5		
MASK POS	:	T=0	B=0	L=0	R=0	:

◆ **Signal Mask**

Video inputs can be used for mask signals instead of Box. The input used for a mask must be assigned to an AUX bus. Combined video signals such as program or multi-view cannot be used.

- (1) Open [KEY1 - MASK] menu PAGE 1. (See the previous page.)
- (2) Turn **F3** to select a mask signal.
- (3) If you want to invert a key signal, turn **F4** to **ON**.
- (4) Set **TYPE** to **AND** or **OR**.

KEY1	:	TYPE	:	BOX MSK:MASK(EXT/PST)	:	1/5
MASK	:	=AND	:	=OFF	:	S= AUX4 :INV= ON

◆ **Preset Mask**

WIPE patterns can be used for mask signals for KEY1 and KEY2.

- (1) Open the [KEY1 - MASK] menu PAGE 1. (See the previous page.)
- (2) Turn **F3** to select **PST** (PRESET).
- (3) If you want to invert a key signal, turn **F4** to **ON**.
- (4) Set **TYPE** to **AND** or **OR**.

KEY1	:	TYPE	:	BOX MSK:MASK(EXT/PST)	:	1/5
MASK	:	=AND	:	=OFF	:	S= PST :INV= ON

- (5) Press **PAGE DOWN** to go to PAGE 3.
- (6) Turn **F1** to select a wipe pattern.
- (7) Turn **F4** to change the pattern shape.

KEY1	:	PATTERN		:	:	LEVEL	:	3/5
WIP PTRN:	=	51		:	:	=	50.0	:

- (8) Mask patterns can be modified referring to PAGE 4 and 5

KEY1	:	POSITION	:	ANGLE	:	ASPECT	:	4/5
WIP POS	:	X=0	Y=0	:	=0.0	=0.0	:	

KEY1	:	MULTI	:	SOFT	:		:	5/5
WIP MULT:	:	X=1	Y=1	:	=0.0		:	

9-7. Key Edge

The EDGE function allows users to add border type edges on KEY1 and KEY2. Two types of edges are available: Normal and Outline. The width, transparency, and color can be set for the edges. Shadow effects can also be added by changing the position of edges. This chapter shows how to add a key edge using KEY1 as an example.

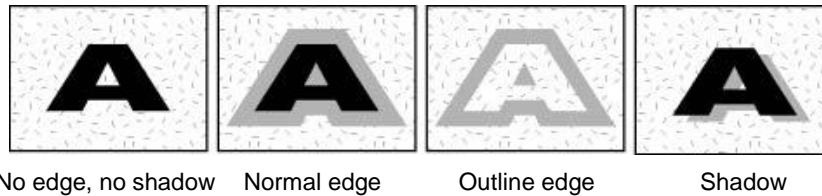

- (1) Go to the [KEY1 - EDGE] menu. Turn **F1** to select **NORMAL** or **O_LINE** for **TYPE**. Selecting **NORMAL** allows users to add edges. **O_LINE** allows users to display outlines without key fill images.
- (2) The **SOFT** parameter is for setting softness, **TRANSP** is for transparency, and **WIDTH** is for edge width.

KEY1	:	TYPE	:	SOFT	:	TRANSP	:	WIDTH	:	1/3
EDGE	:	O_LINE	:	=0	:	=0	:	=1	:	:

- (3) Press the page down button to go to PAGE2. Change the **X** and **Y** values to set the edge position.

KEY1	:	POSITION	:	:	:	2/3
EDGE	POS:	X=0	Y=0	:	:	:

- (4) Press the page down button to go to PAGE3. The edge color can be set on this page. Turn **F4** to select a color among eight standard colors. If you wish to use a color other than the standard eight, adjust the color by turning **F1**, **F2** and/or **F3**.

KEY1	:	EDGE COLOR	:	RECALL	:	3/3
EDGE	COL:	S=0.0	L=0.0	H=0.0	:	>BLACK:

9-8. DVE Effects on KEY/DSK

Dedicated 2D-DVE(2.5D) effects are available for each key in the standard configuration. 2D-DVE is available just by setting **2D DVE** to **ON** in each key menu. As an example, this section explains how to add a 2D-DVE effect on KEY1.

9-8-1. How to Enable 2D DVEs

- (1) Press the **KEY1** transition button in the bottom right corner of the control panel to display KEY1 on the PGM video.
- (2) Press **MENU** in the SELECT/KEYPAD block.
- (3) Press the **KEY1** button to display the [KEY1 SETUP] menu.

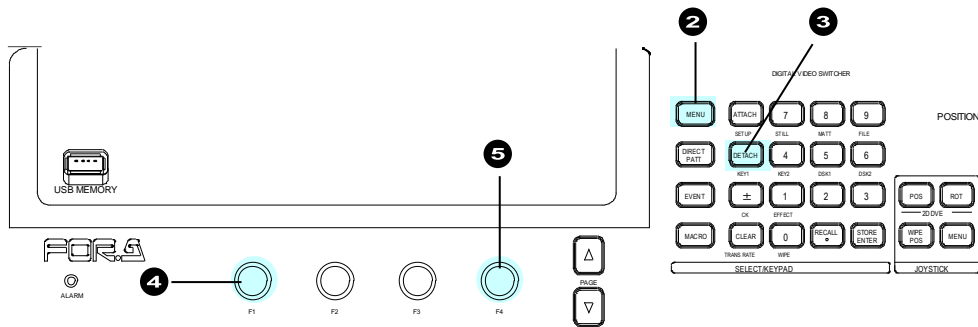

- (4) Turn **F1** to select **POS/SIZE**, then press **F1** or the page down button to display the [KEY1 - POS/SIZE] menu

KEY1	:>INS/SRC	>EDGE	>MASK
SETUP	:> POS/SIZ	>BORDER	>INIT

- (5) Turn **F4** to set **2D DVE** in the menu to **ON**.

KEY1	:	POSITION	:	SIZE	:	2D DVE	:	1/5
POS/SIZE	:	X=0	Y=0	:	=1000	:	= ON	:

The 2D DVE function is enabled for KEY1, and therefore the POS/SIZE and BORDER menus for KEY1 become available.

If 2D DVE cannot be set to ON:

Up to 4 channels of DVE can be assigned to BKGD, KEY1-2 and DSK1-2. If no free DVE channels remain, 2D DVE cannot be enabled. In such case, deselect the assigned DVE channels as shown below to create free channels.

Set **2D DVE** to **OFF** (for KEY and DSK)

- ▶ See section 9-8-1. "How to Enable 2D DVEs."

Change transitions from **WIPE** (pattern: 100-137) to **MIX** (for KEY and BKGD):

- ▶ See section 8-3. "Background Transitions" and section 8-4. "KEY Transitions."

9-8-2. Changing Position and Size

The position and size of key images can be changed using the menu or joystick as follows:

Using the Joystick:

- (1) Press the **KEY1** menu button (with **MENU** lit) while holding down **POS** in the joystick block.
- (2) Change the KEY1 position by moving the joystick up, down, left and right.

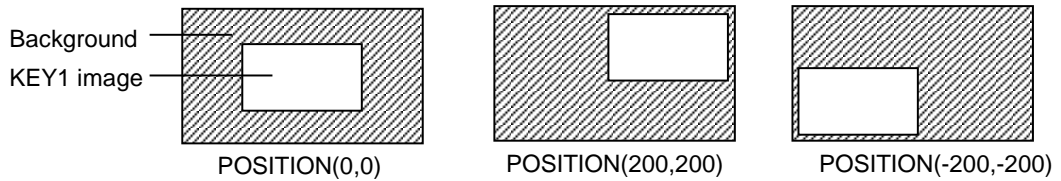

Change the key size by turning the **SIZE** control in the joystick block.

The figures below are examples of **SIZE=500** and **750** when **POSITION** is set to (0, 0).

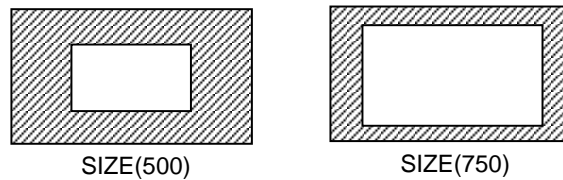

Using the Menu

- (1) Double-press **POS** in the joystick block to display [KEY1 - POS/SIZE] menu PAGE1.
- (2) Turn **F1** or **F2** to set the position of the KEY1 image.

KEY1	:	POSITION	:	SIZE	:	2D DVE	:	1/5
POS/SIZE	:	X=0	Y=0	:	=500	:	=ON	:

- (3) Turn **F3** to set the size of the KEY1 image.

KEY1	:	POSITION	:	SIZE	:	2D DVE	:	1/5
POS/SIZE	:	X=0	Y=0	:	=500	:	=ON	:

The original base POSITION of a key is at the center of the output screen. You can set the position of the key images by specifying X and Y coordinates, with the origin of the axes located at the center of the screen.

Setting the size allows users to change the size of key images while retaining aspect ratios. If the value is 1,000, the key images will be full-screen size.

9-8-3. Changing the Aspect Ratio

- (1) Go to the [KEY1 - POS/SIZE] menu PAGE 2.
- (2) Press **MENU** in the joystick block.
- (3) Change the KEY1 **ASPECT** values by moving the joystick up, down, left and right.

KEY1	:	ASPECT	:	FADE LV:	:	2/5
ASPECT	:	X=1000	Y=1000	:	=0.0	:

(The figures below are examples when **POSITION** is set to (0, 0).)

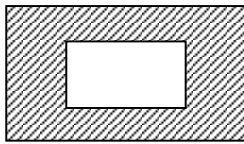

(500, 500)

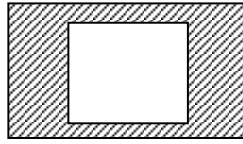

(500, 750)

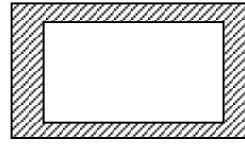

(750, 750)

9-8-4. FADE

FADE allows users to add an effect to make backgrounds transparent.

- (1) Go to the [KEY1 - POS/SIZE] menu PAGE 2.
- (2) Turn **F3** to set the **FADE** level for the KEY1 image. Increasing the value makes the background transparent.

KEY1	:	ASPECT	:	FADE LV:	:	2/5
ASPECT	:	X=1000	Y=1000	:	=0.0	:

9-8-5. Rotation

In addition to positional and size changes, users can add a rotation effect to key images.

◆ Specifying the Rotation Angle (Number of Rotation)

Using the Joystick

- (1) Press **ROT** for 2D DVE in the joystick block.
- (2) Move the joystick (X/Y-axes) and SIZE control (Z-axis) to change the rotation angles.

Using the Menu

- (1) Go to PAGE 3 of the [KEY1 - POS/SIZE] menu.
- (2) Turn **F1** to **F3** to change rotation angles in the X, Y and Z directions.

KEY1	:	LOCAL ROTATION	:	:	3/5
ROTATION: X=	0	Y=	0	Z=	0

The **LOCAL ROTATION** values allow the key image around the base point to rotate up to approximately eight times in the positive or negative direction.

X-Rotation: Rotates around the Y-axis.

Y-Rotation: Rotates around the X-axis.

Z-Rotation: Rotates around the origin.

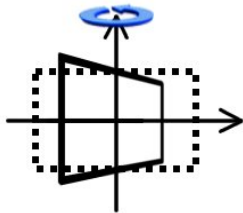

X-Rotation
LOCAL ROTATION
(100,0,0)

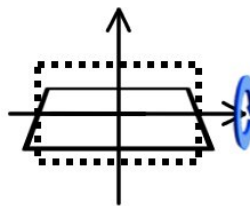

Y-Rotation
LOCAL ROTATION
(0,100,0)

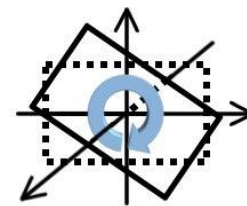

Z-Rotation
LOCAL ROTATION
(0,0,100)

In the factory default setting, the base point coordinates (0,0,0) coincide with the center point of the key image. The figure examples above show them rotating around the base point (0, 0, 0). Changing the CENTER POSITION values in the menu allows the base point to move.

◆ Moving the Center of Rotation

Using the Joystick

- (1) Simultaneously press **POS** and **ROT** for 2D DVE in the joystick block to turn them on.
- (2) Move the joystick (X/Y-axes) and SIZE control (Z-axis) to move the center of rotation.

Using the Menu

- (1) Go to PAGE 4 of the [KEY1 - POS/SIZE] menu.
- (2) Turn **F1** to **F3** to move the center of rotation.

KEY1	:	CENTER POSITION	:	:	4/5
ROTATION: X=	0	Y=	0	Z=	0

◆ **Setting Example**

- (1) Set the key position and size on PAGE 1 of the [KEY1 - POS/SIZE] menu. Note that the position is two-dimensional and its origin is placed on (0, 0), which coincides with the center of the screen. The position values represent the distance between the origin and the center of the KEY1 images. These values will be positive if the center of the key image is above the origin and negative if it is below the origin.

KEY1	:	POSITION	:	SIZE	:	2D DVE	:	1/5
POS/SIZE:	X=-200	Y=-200	:	=500	:	=ON	:	

To enter a negative number, enter the number, press \pm , then press **ENTER**.

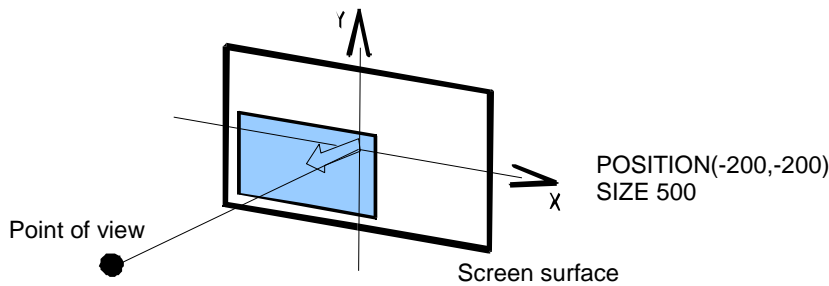

- (2) Change the center of rotation on PAGE4 of the [KEY1 - POS/SIZE] menu. To rotate the key image at the current POSITION, leave CENTER POSITION (0, 0, 0) unchanged.

KEY1	:	CENTER POSITION	:	:	:	4/5
ROTATION:	X=150	Y=-200	Z=-400	:	:	

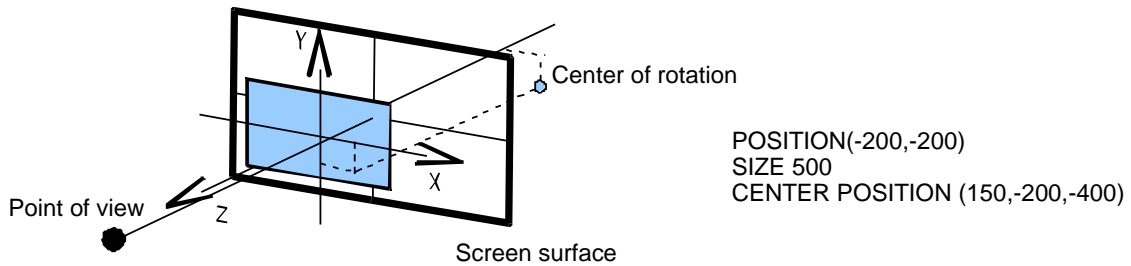

- (3) Set the rotation value on PAGE3 of the [KEY1 - POS/SIZE] menu.

KEY1	:	LOCAL ROTATION	:	:	:	3/5
ROTATION:	X=100	Y=100	Z=100	:	:	

[Example 1] X-axis Rotation

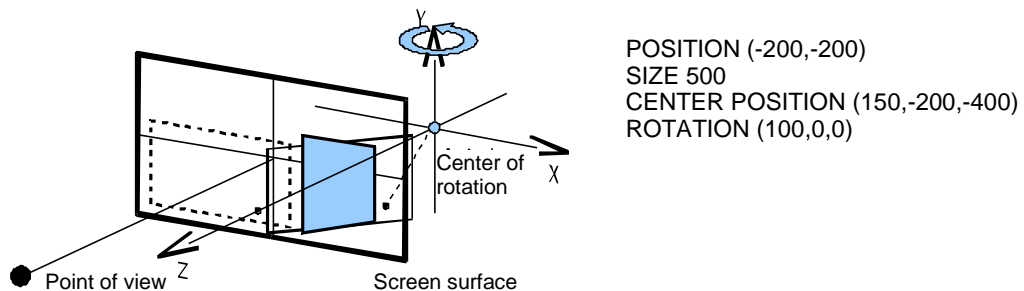

[Example 2] Y-axis Rotation

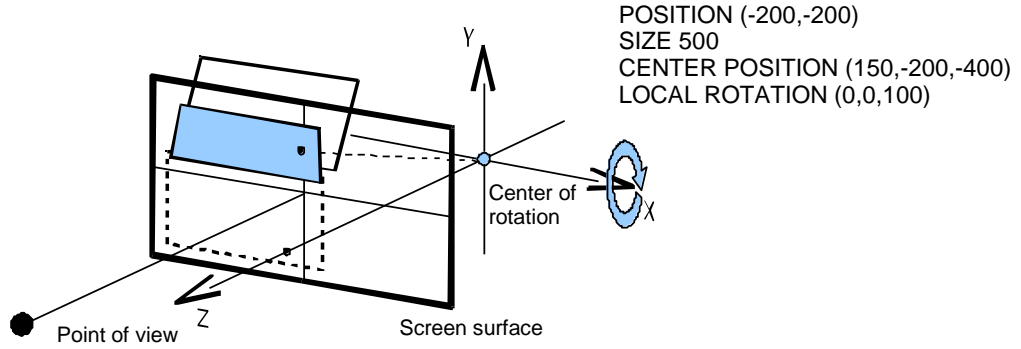

[Example 3] Z-axis Rotation

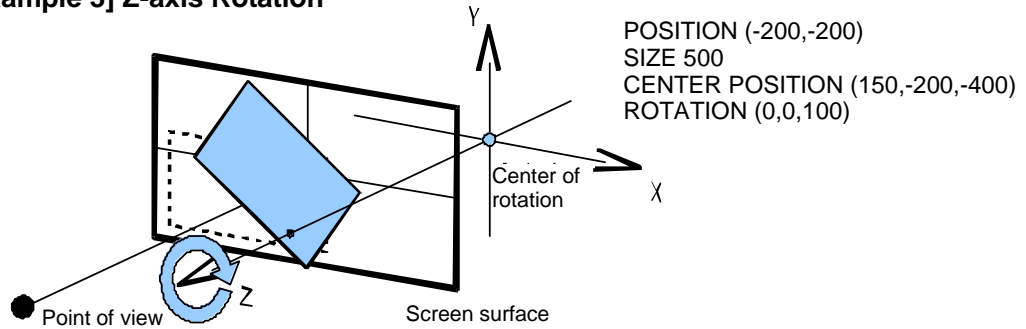

9-8-6. CROP

CROP allows users to trim a key image from all four directions. The background image then only remains visible in the cropped area.

(1) Go to PAGE5 of the [KEY1 - POS/SIZE] menu.

KEY1	:	CROP POSITION	:	5/5	
CROP	:	T=0	B=0	L=0	R=0

(2) Use **F1**, **F2**, **F3** and/or **F4** to crop the KEY1 image.

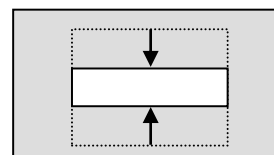

Crops from top and bottom.

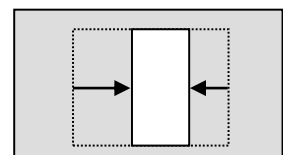

Crops from right and left.

9-8-7. BORDERS

Borders can be added to key images. Inside borders and outside borders can be adjusted independently.

- (1) Go to the [KEY1 - BORDER] menu.
- (2) To use the inside border, set the width on the **INSIDE X** and **Y**. To use the outside border, set the width on the **OUTSIDE X** and **Y**.

KEY1	:	INSIDE	:	OUTSIDE	:	1/3	
BORDER	:	X=0	Y=0	:	X=0	Y=0	:

- (3) Press the page down button to go to PAGE2. In this menu, border softness can be adjusted. **INSIDE X** and **Y** allow users to set softness for the inner half of a set border. The softness of the outer half of the border is set at **OUTSIDE**.

KEY1	:	INSIDE	:	OUTSIDE:	:	2/3
BDR SOFT	:	X=0	Y=0	:	=0	:

- (4) Press the page down button to go to PAGE3. Turn **F4** to select a color among eight standard colors, then press **F4**. To use a different color, turn **F1**, **F2**, and **F3** to adjust the color.

► See section 5-9-1. "Setting the Matte Color."

KEY1	:	BORDER COLOR	:	RECALL	:	3/3
BDR COL	:	S=66.3	L=5.4	H=3.5	:	>BLUE

Inside Border

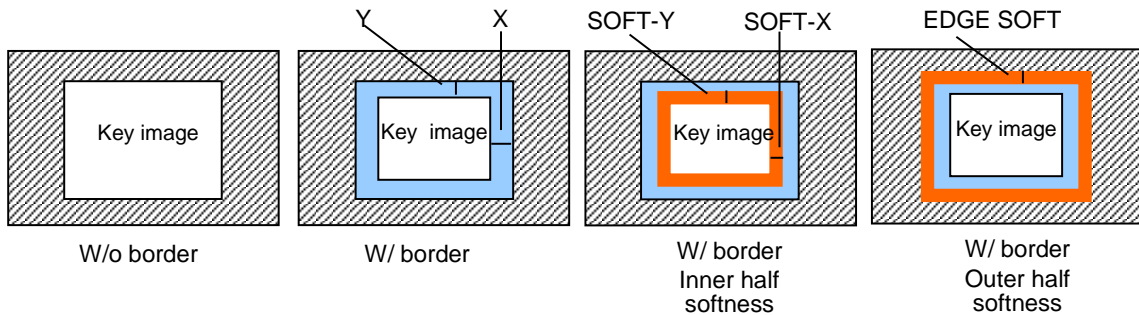

Outside Border

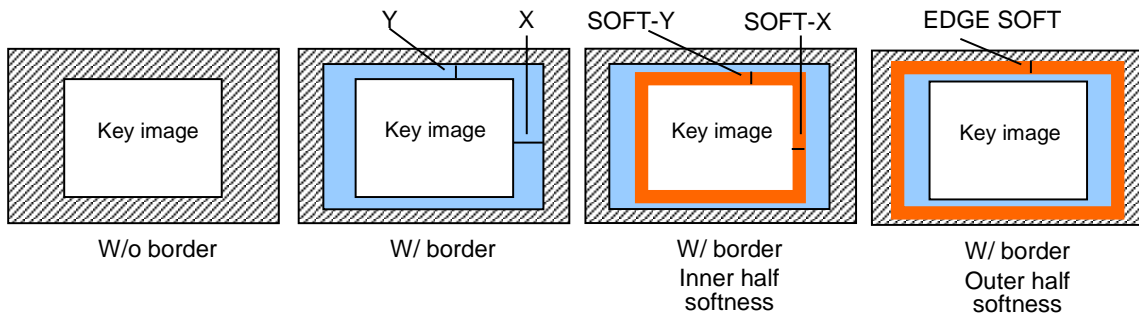

10. Chromakey

The chromakey method of key signal creation, which uses a chroma component instead of a luminance component, is mostly used to composite moving subjects such as a person inside a virtual background environment. For example, to place a person over a virtual background, first film the person standing in front of a background such as a blue screen. The blue part of the filmed image is detected and will be used to create the key signal.

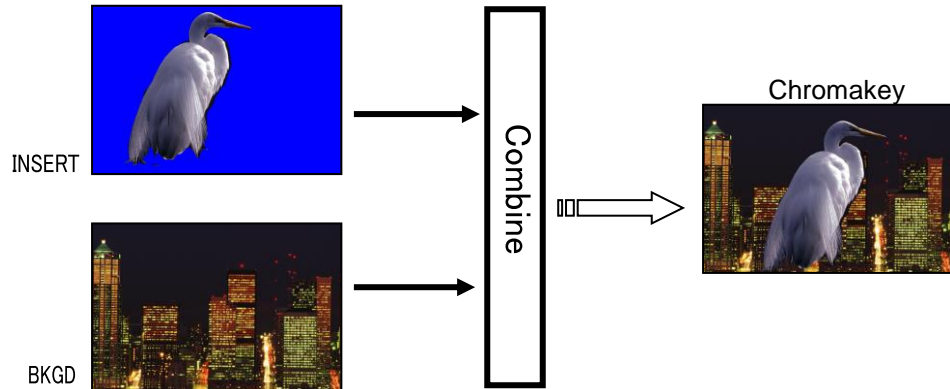

The switcher has a **single chromakey generator**, which generates chromakey **Fill and Key signals** by specifying a video signal and chromakey color. The Fill and Key signals can be **output respectively from AUX** outputs, and assigned to any KEY or DSK on the switcher to **display the output onto the background video**.

This chapter explains how to create and combine a chromakey with background video and adjust the appearance using KEY1 as an example .

10-1. Creating a Chromakey

Setting Up KEY1

- (1) Select a signal to be used as a background on the PGM bus.
- (2) Double-press **KEY1** above the KEY/AUX block to display the [KEY1 SETUP] menu
- (3) Turn **F1** to select **INS/SRC**, and press **F1** or the page down button.
- (4) The **[KEY1 - INS/SRC]** menu is displayed. Turn **F1** to set **TYPE** to **BUS**.
- (5) Turn **F2** to set **INSERT** to **CKFL** and turn **F3** to set **SOURCE** to **CKKY**.

KEY1	:	TYPE	:	INSERT	:	SOURCE	:	INVERT	:	1/4
INS/SRC	:	= BUS	:	> CKFL	:	= CKKY	:	=OFF	:	

- (6) Press the **KEY1** transition button in the bottom right of the control panel to display KEY1 on the PGM image.

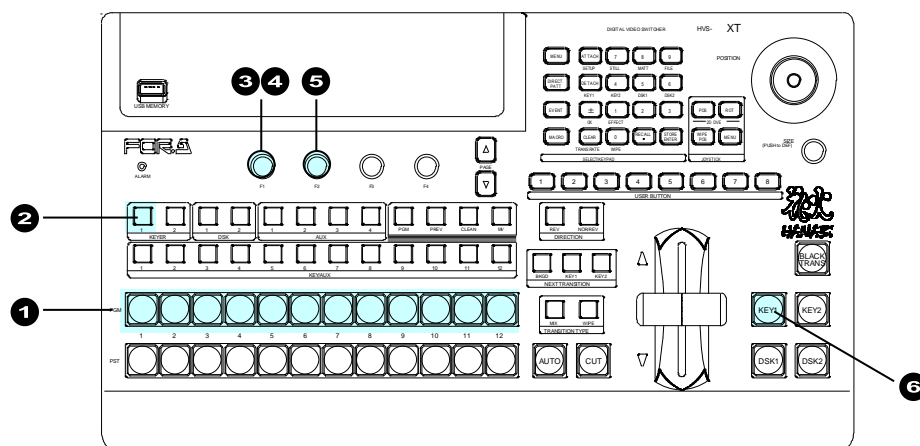

Creating a Chromakey

- (1) Press **MENU**, then **CK** in the SELECT/KEYPAD block to display the [CHR KEY SETUP] menu.
- (2) Turn **F1** to select **AUTO CK**, then press **F1** to display the [CHR KEY - AUTO CK] menu.
- (3) Turn **F4** to select a signal used for chromakey under **SIGNAL**.
- (4) Turn **F3** to change **SELECT** to **ON** to activate the Auto Chroma key.

CHR KEY :	POSITION	:SELECT :	SIGNAL :	1/2
AUTO CK :	X=0 Y=0	: = ON	: = IN01	:

- (5) KEY1 is displayed on the topmost layer of the **Preview** image and a cross hair cursor appears. The current position of the cursor is displayed at **POSITION X** and **Y** in the [CHR KEY - AUTO CK] menu.

If the preview picture is not displayed, press an AUX button, then **PREV** to display the preview picture on the screen.
 If you need to have a crosshair cursor also appear on the PGM screen, set **PGM OUT** to ON in the [CHR KEY - AUTO CK] (2/2) menu.

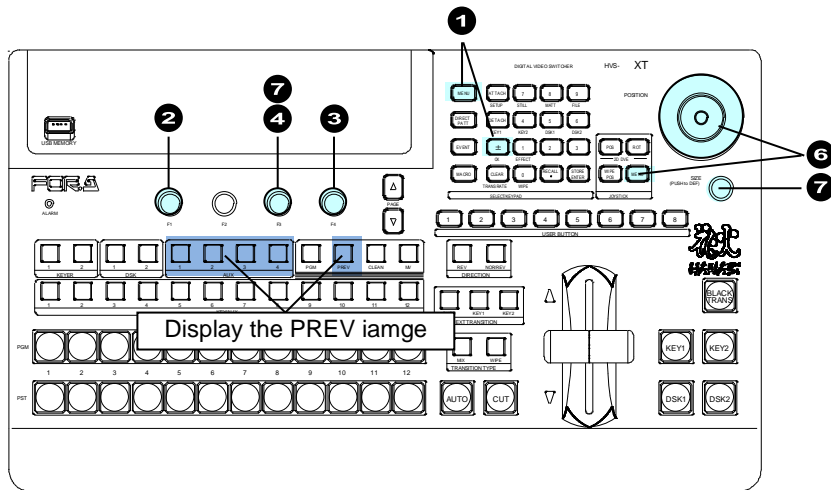

- (6) Press **MENU** in the joystick block. Move the joystick up, down left and right to move the crosshair cursor onto the desired color. To precisely adjust the position, turn **F1** and **F2** to set **POSITION X** and **Y**. Selecting a darker color makes adjustment easier.
- (7) To create a chromakey, turn the **SIZE** control in the joystick counter-clockwise. Or, turn **F3** to set **SELECT** to **OFF**.

CHR KEY :	POSITION	:SELECT :	SIGNAL :	1/2
AUTO CK :	X= 100 Y= 400	: = OFF	: = IN01	:

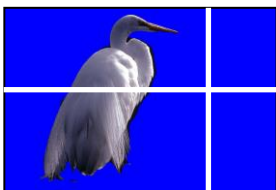

Preview screen

Move the crosshair with the joystick along the X-Y axes and twist the **SIZE** control counter-clockwise to create a Chroma key.

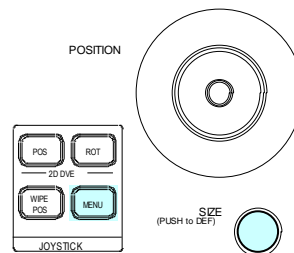

10-2. Adjusting Chromakey

If the desired result is not achieved using the automatic chromakey generation procedure, fine adjustments can be made as follows:

Adjust key levels to make the background clear.
▶ See section 10-2-1.



Use EDGE SHRINK and EDGE REPLACE to smooth chroma key edges.
▶ See section 10-2-3.

Use COLOR CANCEL and SUPPRESSION to eliminate or reduce color noise on the bird.
▶ See section 10-2-2.

10-2-1. Adjusting Key Levels

(1) Adjusting the Chromakey Color

Open the [CHR KEY - ADJUST] (1/5) menu.

Finely adjust the chromakey color using the **SAT**, **LUM** and **HUE** parameters.

CHR KEY	:	SAT	:	LUM	:	HUE	:		:	1/5
BKGND	:	=0.0	:	=0.0	:	=0.0	:		:	

(2) Adjusting the KEY Cut Signal (Background)

Remove unwanted noise from the background areas (blue or green wall and floor) following the procedure below.



Remove noises while monitoring the key cut image.

(a) Open the [CHR KEY - MATTE] (3/3) menu.

CHR KEY	:	LUM	:	RED	:	GREEN	:	BLUE	:	3/3
CORING	:	=OFF	:	=OFF	:	=OFF	:	=OFF	:	

Set the following 4 parameters to **ON** one by one and check the chromakey image. If not noticeable changes appear in the image, return the setting to **OFF**.

LUM CORING	Effective for areas illuminated un-uniformly.
GREEN CORING	Effective for areas that are colored green unevenly.
BLUE CORING	Effective for the areas that are colored blue unevenly.
RED CORING	Effective for the areas that are colored red unevenly.

(b) Reduce the **WHITE** or **BLACK** value in [CHR KEY - ADJUST] menu PAGE 2 or 3. If not noticeable changes appear in the image, return the setting to the previous value.

WHITE	Effective for bright walls and flooring
BLACK	Effective for dark walls and flooring.

CHR KEY	:	DENSITY	:	SOLDNES	:		:	WHITE	:	2/5
DENSITY	:	=0	:	=0	:		:	=0	:	

CHR KEY	:	BLACK	:	RED	:	GREEN	:	BLUE	:	3/5
DENSITY	:	=0	:	=0	:	=0	:	=0	:	

(3) Adjusting the KEY Cut Signal (Foreground)

Remove unwanted noise from foreground areas (figures or objects) following the procedure below.

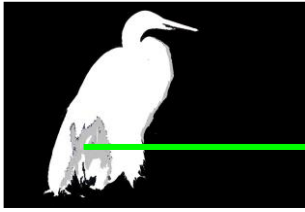

Remove noises while monitoring the key cut image.

- (a) Use the parameters in the [CHR KEY - ADJUST] menu PAGE 2 and 3 to decrease the level one by one and check the chromakey image. If not noticeable changes appear in the image, return the setting to the previous value.

WHITE	Effective for blue or green reflections on white hair, skin or clothes.
BLACK	Effective for blue or green reflections on black hair, skin or clothes.
RED	Effective for blue or green reflections on the reddish hair, skin or clothes.
GREEN	Effective for strong green reflections.
BLUE	Effective for strong blue reflections.

(4) If the key level of the Foreground is not high enough:

Gradually increase the **SOLIDNESS** value (about 10 for each) in PAGE 2 and repeat Steps (2) and (3).

10-2-2. Adjusting the Foreground Image (Chromakey Color)

(1) Foreground (FILL) Coarse Adjustment

Adjust the foreground image coarsely following the procedure below.

Set **SELECT** to **ON** in the [CHR KEY - ADJUST] (4/5) menu.

Increase the **SUPPRESSION** value to reduce the blue or green reflections. At this moment, you may substantially suppress reflections until unnecessary areas are affected.

CHR KEY	: SELECT	: SUPPRES	: SOLDNES	: WHITE	: 4/5
SUPPRES	: =ON	: =0	: =0	: =0	:

(2) Foreground (FILL) Fine Adjustment

Finely reduce background reflections on the foreground image following the procedure below.



Reduce the background reflections while monitoring the mixed image.

Use the parameters in [CHR KEY - ADJUST] menu PAGE 4 and 5 (shown in the next page) to reduce reflections.

WHITE	Effective for reflections on white hair, skin or clothes.
BLACK	Effective for reflections on black hair, skin or clothes.
RED	Effective for reflections on reddish hair, skin or clothes.
BLUE	Effective for strong blue reflections.
GREEN	Effective for strong green reflections.

```
CHR KEY : SELECT : SUPPRES : SOLDNES : WHITE : 4/5
SUPPRES : =ON : =0 : =0 : =0 :
```

```
CHR KEY : BLACK : RED : GREEN : BLUE : 5/5
SUPPRES : =0 : =0 : =0 : =0 :
```

(3) If the Color is not restored:

Gradually decrease the **SOLIDNESS** value (about 10 levels for each setting) and repeat Step (2).

10-2-3. Adjusting Edges

EDGE SHRINK and EDGE REPLACE parameters allow users to adjust chromakey edges.

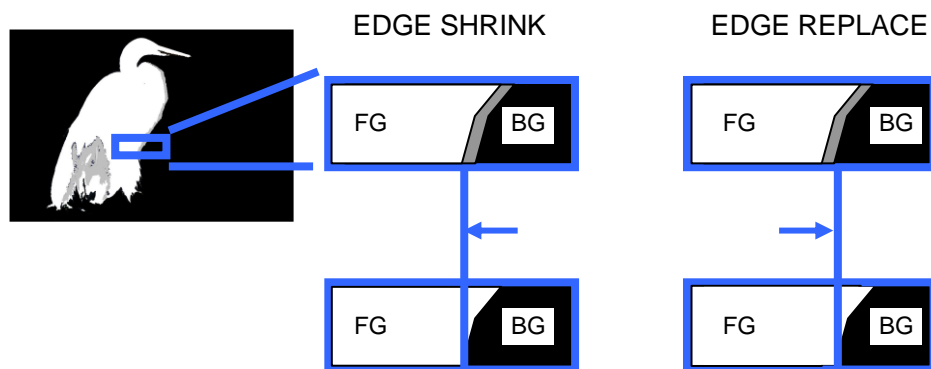

◆ **To Shrink Foreground Edges by Replacing them with the Background Video (EDGE SHRINK)**

Open the [CHR KEY - MATTE] (1/3) menu.
Set EDGE SHRINK (TOP, BOTTOM, LEFT, RIGHT) to ON.

```
CHR KEY : EDGE SHRINK : 1/3
CK ADJT : T=ON B=ON L=ON R=ON :
```

◆ **To Replace Background Edges with the Foreground Video (EDGE REPLACE)**

Open the [CHR KEY - FOREGND] (2/2) menu.
Set EDGE REPLACE (TOP, BOTTOM, LEFT, RIGHT) to ON.

```
CHR KEY : EDGE REPLACE : 2/2
FOREGND : T=ON B=ON L=ON R=ON :
```

10-3. Chromakey Menu

To display the Chromakey menu, press **MENU**, then **CK** in the SELECT/KEYPAD block. To create and adjust a Chromakey, go to each submenu and set or adjust parameters.

10-3-1. [CHR KEY - ADJUST] Menu

```
CHR KEY :>AUTO CK >ADJUST >MATT >FORGRND
SETUP :>INIT
```

```
CHR KEY : SAT : LUM : HUE : : 1/5
BKGND : =0.0 : =0.0 : =0.0 : : :
```

Parameter	Default	Setting range	Description
SAT	0.0	0.0-100.0	Finely adjusts the chromakey reference color using these three parameters.
LUM	0.0	0.0-100.0	
HUE	0.0	0.0-359.9	

```
CHR KEY :DENSITY:SOLDNES: : WHITE : 2/5
DENSITY : =0 : =0 : : =0 :
```

```
CHR KEY : BLACK : RED : GREEN : BLUE : 3/5
DENSITY : =0 : =0 : =0 : =0 :
```

Parameter	Default	Setting range	Description
DENSITY	0	-100 to 100	Reduces edge spills (reflections) between foreground and background adjusting the density or solidness of the reference color.
SOLIDNESS	0	-100 to 100	
WHITE	0	-100 to 100	Finely adjusts DENSITY of the reference color.
BLACK	0	-100 to 100	
RED	0	-100 to 100	
GREEN	0	-100 to 100	
BLUE	0	-100 to 100	

```
CHR KEY :SELECT :SUPPRES:SOLDNES: WHITE : 4/5
SUPPRES : =OFF : =0 : =0 : =0 :
```

```
CHR KEY : BLACK : RED : GREEN : BLUE : 5/5
SUPPRES : =0 : =0 : =0 : =0 :
```

Parameter	Default	Setting range	Description
SELECT	OFF	OFF, ON	Sets Color Suppression ON/OFF. If set to OFF , all other parameters in PAGE 4 and 5 are disabled .
SUPPRESSION	0	-100 to 100	Applied when creating the foreground (FILL) video. This can be used to reduce background reflections on the foreground.
SOLIDNESS	0	-100 to 100	Adjusts the color boundaries applied to Color Suppression.

WHITE	0	-100 to 100	Finely adjusts SUPPRESSION.
BLACK	0	-100 to 100	
RED	0	-100 to 100	
GREEN	0	-100 to 100	
BLUE	0	-100 to 100	

10-3-2. [CHR KEY - MATT] Menu

```
CHR KEY :>AUTO CK >ADJUST >MATT >FORGRND
SETUP   :>INIT
```

```
CHR KEY :          EDGE SHRINK          : 1/3
CK ADJT :T=OFF    B=OFF    L=OFF    R=OFF :
```

```
CHR KEY :PST F H:POS F V:RCSV FL:      : 2/3
FILTER  : =OFF   :Y=OFF   :C=OFF   :      :
```

```
CHR KEY : LUM     : RED     : GREEN  : BLUE   : 3/3
CORING  : =OFF   : =OFF   : =OFF   : =OFF   :
```

Parameter		Default	Setting range	Description
EDGE SHRINK	T	OFF	OFF, ON	Setting ON narrows the upper foreground boundary.
	B	OFF	OFF, ON	Setting ON narrows the bottom foreground boundary.
	L	OFF	OFF, ON	Setting ON narrows the left- hand boundary of the foreground.
	R	OFF	OFF, ON	Setting ON narrows the right-hand boundary of the foreground.
POST FILTER H		OFF	OFF, ON	Smoothes the Matte horizontal edge.
POST FILTER V		OFF	OFF, ON	Smoothes the Matte vertical edge.
RECURSIVE FILTER		OFF	OFF, ON	Enables/disables the filter, which reduces flicker noise.
CORING	LUM	OFF	OFF, ON	Enables/disables luminance coring, which eliminates luminance component noise.
	RED	OFF	OFF, ON	Enables/disables the red coring, which eliminates red component noise.
	GREEN	OFF	OFF, ON	Enables/disables the green coring, which eliminates green component noise.
	BLUE	OFF	OFF, ON	Enables/disables the blue coring, which eliminates blue component noise.

10-3-3. [CHR KEY - FORGND] Menu

```
CHR KEY :>AUTO CK >ADJUST >MATT >FORGRND
SETUP   :>INIT
```

```
CHR KEY :RSV FLT:L&D EMP:           : 1/2
FOREGND : =0      : =0      :       :
```

```
CHR KEY :           EDGE REPLACE     : 2/2
FOREGND :T=OFF    B=OFF    L=OFF    R=OFF :
```

Parameter	Default	Setting range	Description
RECURSIVE FILTER	OFF	OFF, ON	Enables/disables the filter, which reduces flicker noise.
LIGHT&DARKNES EMPHASI	OFF	OFF, ON	Setting ON increases the contrast ratio: bright parts become brigher and dark parts become darker based on the back color luminance level.
EDGE REPLACE	T	OFF	Setting ON change edge colors to the foreground object color.
	B	OFF	
	L	OFF	
	R	OFF	

10-3-4. Resetting Chromakey Settings

(1) Display the [CHR KEY - INIT] submenu.

```
CHR KEY :>AUTO CK >ADJUST >MATT >FORGRND
SETUP   :>INIT
```

(2) If you want to keep the **SIGNAL** setting in the [CHR KEY - AUTO CK] (1/2) menu (Chromakey source signal), set **XPT HOLD** to **ON**.

(3) Turn **F1** to set **INIT** to **ALL**, then press **F1**.

```
CHR KEY :INIT      :XP HOLD:           : 1/1
INIT    : =ALL    : =OFF   :         :
```

10-4. Assigning the Chromakey to Another KEY or DSK

The following example shows how to use the Chromakey set up for KEY1 (background video: PST) in DSK1.

- (1) Open the [SETUP - FUNCTION - M/E KEY] menu. Turn **F3** to change the DSK1 display from PGM to AUX3 (Do not select PGM for the AUX3 video.). Press **F3** to apply the change.

```
FUNCTION:TRSEdge:KEY LNK:  DSK ASSIGN   : 1/1
M/E KEY  : =ON      : =ON      : 1=AUX3  2=M/E  :
```

- (2) Double-press **DSK1** above the KEY/AUX bus to display the menu.

- (3) Turn **F2** to set INSERT to CKFL and turn **F3** to set SOURCE to CKKY.

```
DSK1      : TYPE   :INSERT :SOURCE :INVERT : 1/4
INS/SRC   : =BUS   : >CKFL : =CKKY : =OFF   :
```

- (4) Press **DSK1** in the transition block to display DSK1 on the AUX3 video.

If assigning the same video as PST to the AUX3 background, the chromakey can be used without any adjustments.

10-5. Sending Chromakey Signals to Other Devices

Display the [SETUP - OUTPUT - OUT XPT] menu. Use three AUX outputs and assign them to **the chromakey background video, CKFIL and CKKY**. Doing this allows the switcher to be used as a Chromakeyer.

- See section 6-1-2. "Selecting Video from Menu Selection."

11. SUB EFFECT Channel

The SUB EFFECT menu allows users to add MONO COLOR, DEFOCUS, and PAINT COLOR effects to input video or still images. **Two SUB EFFECT channels** can be used in the switcher. Video that is output from these channels are called SBEF1 and SBEF2 and can be directly output to other devices and used as key fill, key source and background signals. They can also be assigned to bus buttons.

- ▶ See section 5-2. "How to Assign Sources to Bus Buttons."
- ▶ See section 6-1-2. "Selecting Video from Menu Selection."

11-1. Selecting a SUB EFFECT Channel and Source Signal

Access the SUB EFFECT menu as shown below. The setting example below uses the **SUB EFFECT 1** channel and effects are applied to **IN01**.

- (1) Press **MENU**, then **EFFECT** in the SELECT/KEYPAD block to display the [EFFECT SETUP] top menu.
- (2) Turn **F1** to select **SUB EFF1** or **SUB EFF2**, then press **F1** or the page down button to display the submenu.

```
EFFECT  :>SUBEFF1 >SUBEFF2 >INIT
SETUP   :
```

- (3) Turn **F1** to select a source signal to which effects are applied.

```
SUB EFF1: XPT      :      MONO COLOR      : 1/3
MONO     : =IN01  :S=0      H=0      En=OFF  :
```

11-2. MONO COLOR

Monochrome effects can be configured via this menu.

- (1) Display [SUB EFFECT1] PAGE 1.
- (2) Turn **F4** to set **EN** (ENABLE) to **ON**.
- (3) Set the color by adjusting its **S** (SATURATION) and **H** (HUE) values.

```
SUB EFF1: XPT      :      MONO COLOR      : 1/3
MONO     : =IN01   :S=0      H=0      En=ON  :
```

11-3. DEFOCUS

The DEFOCUS function allows users to add an effect that will blur the output image.

- (1) Display [SUB EFFECT1] PAGE 2.
- (2) Turn **F1** to set the horizontal defocus level at item **H** (HORIZONTAL).
- (3) Turn **F2** to set the vertical defocus level at item **V** (VERTICAL).

```
SUB EFF1:      DEFOCUS      :      PAINT      : 2/3
DEFOCUS  :H=40.0 V=50.0 :Y=0      C=0      :
```

11-4. PAINT COLOR

The Paint color effect allows users to add an effect, which makes the image look like a painting. Increasing the value decreases the degree of gradation, for the image to start resembling a painting.

- (1) Display [SUB EFFECT1] PAGE 2.
- (2) Turn **F3** to set the luminance level at item **Y** (LUMINANCE).
- (3) Turn **F4** to set the chroma level at item **C** (CHROMA).

SUB EFF1: DEFOCUS : PAINT : 2/3
DEFOCUS :H=0.0 V=0.0 :Y= 10 C= 10 :

11-5. FREEZE, STROBE, NEGA, MOSAIC

Freeze, strobe, negative, and mosaic effects are also available.

- (1) Display [SUB EFFECT1] PAGE 3.

SUB EFF1:FREEZE :STROBE : NEGA :MOSAIC : 3/3
FREEZE :=OFF : =OFF : =OFF : =OFF :

- (2) When applying these effects, refer to the table below.

Parameter	Description
FREEZE	Allows users to enable the freeze effect function. Users can select either frame freeze or field freeze.
STROBE	Allows users to enable strobe effects. Increasing the value increases the intervals of flashing light.
NEGA	Setting this function ON makes an image negative by reversing all luminance levels.
MOSAIC	Allows users to use a mosaic effect. Increasing the value enlarges the size of mosaic cells.

Setting Example

SUB EFF1:FREEZE :STROBE : NEGA :MOSAIC : 3/3
FREEZE := FIELD : = 1 : = ON : = OFF :

12. Still and Clip Store

12-1. Managing Still Images

The switcher can capture and memorize up to **2 Video and Key Still pictures** from the switcher output video. Once stills are captured and stored, they can be directly output to other devices and used as key fill, key source and background signals. They can also be assigned to bus buttons.

- ▶ See section 5-2. "How to Assign Sources to Bus Buttons."
- ▶ See section 6-1-2. "Selecting Video from Menu Selection."

Although the stored stills are cleared when the switcher is powered down, they can be backed up to the Still memory in the switcher. Up to 4 still images can be stored to and loaded from the backup memory (MEM1 to MEM4). In addition, stored stills can also be saved to USB flash drives.

12-1-1. Capturing Stills

Let's capture program images using STILL1 as follows:

- (1) Press **MENU**, then **STILL** in the SELECT/KEYPAD block to display the menu
- (2) Select **PGM** under **FILL SOURCE** and **KEY SOURCE**.
- (3) Then press **F1** to save the image to STILL1. A beep will sound and the image will be saved to the selected still memory.

STILL	:	STILL1	:	STILL2	:	FIL SRC:	KEY SRC:	1/5
STORE	:	>FRAME:	>FRAME:	=PGM	:	=PGM	:	

The **program**, **preview**, **clean** and **AUX** images can be captured using Still Stores.

- ▶ See section 6. "Video Outputs" for details on these signals.

NOTE

Note that when a new still is stored, the current still data is cleared and the new still data is overwritten into the memory.

12-1-2. Displaying Still Images

Selecting STILL1 on the PGM bus will display the captured STILL1 image on the PGM screen. Still images can also be assigned to AUX outputs and key images.

The still image loading type can be selected on PAGE 1. For example, to use an odd field image of STILL1 set the menu as shown in the figure below. Selectable options are **FRAME**, **ODD** (odd field) and **EVEN** (even field).

STILL	:	STILL1	:	STILL2	:	FIL SRC:	KEY SRC:	1/5
STORE	:	> ODD	:	>FRAME:	=PGM	:	=PGM	:

12-1-3. Backing-up Stills

- ▶ See section 12-3-1. "Structure for Backing Up Still and Clip Data" for details on the still and backup memory.

◆ To Save Still Images:

- (1) Press **MENU**, then **STILL** in the SELECT/KEYPAD block to display the menu
- (2) Press page down to go to PAGE 2.
- (3) Turn **F1** to select **STIL1** or **STIL2** to be backed up.
- (4) Turn **F2** to select **SAVE>**.
- (5) Turn **F3** to select a memory number from **MEM1** to **MEM4**.
- (6) Press **F2** to save the still to the selected memory number. The backed up stills are preserved after powering off the switcher.

```
STILL   :STILL   : FUNC   :MEMORY :RESUME : 2/5
BACKUP  : =STIL1 : SAVE>  : =MEM1  : =MEM1  :
```



◆ To Load Saved Still Images to Still Memory Manually:

- (1) Open PAGE 2 of the [STILL] menu.
- (2) Turn **F1** to select **STIL1** or **STIL2** to be loaded.
- (3) Turn **F2** to select **<LOAD**.
- (4) Turn **F3** to select the memory number where the desired still image is stored.
- (5) Press **F2** to load the still from the memory buffer.

```
STILL   :STILL   : FUNC   :MEMORY :RESUME : 2/5
BACKUP  : =STIL1 : <LOAD  : =MEM1  : =MEM1  :
```



◆ To Load Saved Still Images to Still Memory Automatically:

- (1) Open PAGE 2 of the [STILL] menu.
- (2) Turn **F1** to select the desired still.
- (3) Turn **F4** to select the memory number where the desired still image is stored. The still images will then automatically load at startup.

```
STILL   :STILL   : FUNC   :MEMORY :RESUME : 2/5
BACKUP  : =STL1  : <LOAD  : =MEM1  : =MEM1  :
```

Turn **RESUME OFF** if you do not wish to recall any data to stills at startup.

```
STILL   :STILL   : FUNC   :MEMORY :RESUME : 2/5
BACKUP  : =STL1  : <LOAD  : =MEM1  : =OFF   :
```

12-2. Managing Clips

Clip stores allow you to record and play output video. Up to **2 video and key pair signals** can also be recorded simultaneously. Clip data can be stored in **2 still memory buffers** with still data. In addition, sequential image files can be transferred from a computer and saved in the memory as a video clip.

► See section 12-4. "Transferring Image Files."

Clips can be saved or played back through STILL1 and 2 and can be also used for CG Wipes. Each clip of up to 7.5 seconds of HD video can be recorded in each clip buffer.

12-2-1. Clip Recording

◆ Recording Video

Let's record the AUX1 video to a clip through STILL1.

- (1) Press **MENU**, then **STILL** in the SELECT/KEYPAD block to display the [STILL] menu.
- (2) Turn **F1** to select **CLIP** under **STILL1**.
- (3) Turn **F3** and **F4** to set both **FILL SRC** and **KEY SRC** to **AUX1**.

```
STILL  :STILL1 :STILL2 :FIL SRC:KEY SRC: 1/5
STORE  : >CLIP  : >FRAME: =AUX1  : =AUX1  :
```

- (4) Go to PAGE 4.
- (5) Turn **F1** to select **STL1** (STILL1).
- (6) Press **F4** while holding down **F3** to begin recording.

```
STILL  :SELECT :          ( STOP ---/0 ): 4/5
CLIP   : =STL1  : >STOP  : >REC   : >PLAY  : F=
```



- (6) Press **F2** (STOP) or **F4** (PAUSE) to stop recording. (Recording is automatically stopped when the memory is full.)

```
STILL  :SELECT :          ( STOP 40/40 ): 4/5
CLIP   : =STL1  : >STOP  : >REC   : >PAUSE: F=40
```



The **program**, **preview**, **clean**, and **AUX** images can be recorded to clips.

► See section 6. "Video Outputs" for details on these signals.

◆ Recording Video and Key Signals Simultaneously

Assume a video signal is assigned to AUX3 and its key signal to AUX4.

If you need to record an input signal such as IN01, assign the signal to an AUX bus before recording.

Let's record AUX3 video and AUX4 key signals simultaneously to clips through STILL 2.

- (1) Open the [STILL] menu PAGE 1.
- (2) Turn **F2** to select CLIP under **STILL2**.
- (3) Select **AUX3** and **AUX4** for **FILL SOURCE** and **KEY SOURCE**, respectively.

```
STILL   :STILL1 :STILL2 :FIL SRC:KEY SRC: 1/5
STORE   : >FRAME: >CLIP  : =AUX3  : =AUX4  :
```

- (4) Go to PAGE 4.
- (5) Turn **F1** to select STL2.
- (6) Press **F4** while holding down **F3** to begin recording.

```
STILL   :SELECT  :          ( STOP ---/0 ) : 4/5
CLIP    : =STL2  : >STOP  : >REC   : >PLAY  : F=0
```



- (7) Press **F2** (STOP) or **F4** (PAUSE) to stop recording.

Loop Recording

Loop recording automatically loops back to the memory start point when it reaches the end of the memory and continues recording overwriting clip frames, until STOP is pressed. If LOOP is set to ON, both playback and recording change to Loop mode. LOOP can be set to ON on PAGE 5 of the [STILL] menu as shown below.

```
STILL   :SELECT  : LOOP   :REC MOD: CLEAR  : 5/5
CLIP    : =STL2  : =ON   : =STD  : >OFF  : F=40
```

Recording Mode

Two modes are available for recording. The recording mode can be set under **REC MODE** on PAGE 5 of the [STILL] menu.

```
STILL   :SELECT  : LOOP   :REC MOD: CLEAR  : 5/5
CLIP    : =STL2  : =OFF   : =STD  : >OFF  : F=40
```

Mode	Description
STD (STANDARD)	Standard mode. In this mode, to start recording, press F4 (PLAY) while holding down F3 (REC) on PAGE 4.
DRCT (DIRECT)	Direct mode. In this mode, to begin recording, press F3 (REC) on PAGE 4.

12-2-2. Playing Clips

◆ Ex. 1: Playing the Recorded Clip on the AUX1 bus

This example shows how to play the recorded clip in the previous section on the background through STILL1. Assume that STILL 1 is assigned to bus button **1**.

- (1) Open PAGE 1 in the [STILL] menu.
- (2) Select **CLIP** for **STILL1**.

```
STILL  :STILL1 :STILL2 :FIL SRC:KEY SRC: 1/5
STORE  : >CLIP : >FRAME: =AUX1 : =AUX1 :
```

- (3) Press bus button **1** on the PGM bus. (The current frame of the clip will be displayed on the monitor.)
- (4) Go to PAGE 4 in the [STILL] menu.
- (5) Press **F4** (PLAY) to begin playing. The video clip is played on the PGM output. (Playback will stop at the last frame and the screen will freeze on the last frame image.)

```
STILL  :SELECT : (STOP 1/40): 4/5
CLIP   : =STL1 : >STOP : >REC : >PLAY : F=40
```

Current frame No.
Clip status | Recorded frames



◆ Ex. 2: Playing the Recorded V/K Clip on KEY1

This example shows how to play the video and key clip recorded in the previous section. Assume an animation logo (V+K) as shown at right is stored in STILL2.

Let's insert the logo through KEY1, then specify the IN and OUT points to perform loop playback.



- (1) Open PAGE 1 in the [STILL] menu.
- (2) Select **CLIP** for **STILL1**.

```
STILL  :STILL1 :STILL2 :FIL SRC:KEY SRC: 1/5
STORE  : >FRAME: >CLIP : =AUX3 : =AUX4 :
```

- (3) Double-press **KEY1** above the KEY/AUX bus to display the [KEY1 SETUP] menu.
Turn **F1** to select INS/SRC then press **F1** to go to the [KEY1 - INS/SRC] menu.
- (4) Turn **F1** to set TYPE to BUS.
- (5) Turn **F2** to select **STL2** (FILL) under INSERT.
- (6) Turn **F3** to select **STK2** (KEY) under SOURCE.

```
KEY1   : TYPE :INSERT :SOURCE :INVERT : 1/4
INS/SRC : =BUS : =STL2 : =STK2 : =OFF :
```

To play clips with video and key signals such as V+K-recorded ones or image files with an alpha channel, key signals must be assigned to dedicated still key channels (STILL KEY1 and STILL KEY2).

- (7) Display KEY1 on the PGM image by pressing **KEY1** to the right side of the fader lever.
All IN/OUT effects for KEY 1 are available.
▶ See section 8-10. "KEY/DSK IN/OUT Effects."
- (8) Go to PAGE 3 in the [STILL] menu. Turn **F1** to select **STL2** (STILL2) and set the IN and OUT points.

STILL	:SELECT	:CUR(100):	IN	:	OUT	:	3/5
CLIP	: = STL2	: =78	:	= 1	:	= 100	: F=100

- (9) Go to PAGE 5 in the [STILL] menu. Turn **F1** to select **STL2** (STILL2) and set LOOP to **ON**.

STILL	:SELECT	: LOOP	:REC MOD:	CLEAR	:	5/5
CLIP	: = STL2	: = ON	: =STD	: >OFF	:	F=100

- (10) Go to PAGE 4 in the [STILL] menu.
(11) Press **F4** (PLAY). The logo animation will play on a loop.

STILL	:SELECT	:	(STOP	1/100):	4/5
CLIP	: = STL2	: >STOP	: >REC	: >PLAY	: F=100



12-2-3. Clearing Clip Data

- (1) Go to PAGE 5 in the [STILL] menu.
(2) Turn **F1** to select a still.
(3) Turn **F4** to set to **ON**. Then press **F4**.

STILL	:SELECT	: LOOP	:REC MOD:	CLEAR	:	5/5
CLIP	: = STL1	: =OFF	: =STD	: > ON	:	F=60



- (4) A confirmation message will appear. Press **ENTER** to clear memory data.

12-3. Backing-up Still and Clip Data using USB Flash Drive

All still and clip backup data can be automatically saved to a USB flash drive. Once the Automatic Backup is enabled, a backup is performed every time the user stores an image or clip to a buffer, STILL1-2, INPUT_STILL1-14 or CLIP1-2.

Automatic backup is performed:

- When still images are sent to a STILL or INPUT_STILL from a USB flash drive.
- When still images or clips are sent to a STILL, INPUT_STILL or CLIP via FTP.
- When capturing and storing input images to a STILL.

Each item of backup data can be automatically loaded at startup as well as manually loaded as needed.

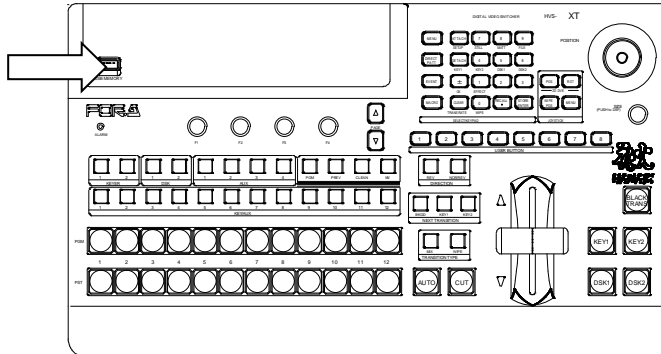

- See "Factory Tested USB Flash Drives" in Appendix 1 for available USB flash drives. Insertion and removal of USB drives should be performed slowly and firmly.
- The access lamp on the USB memory stick blinks while saving or reading data. Check access to the USB memory stick before and during the operations. **Do not** remove the USB memory stick while the access lamp is flashing. Doing so could corrupt the stored data or damage the USB flash drive.
- The remaining amount of storage space on the USB memory device is displayed at the bottom right-hand side in the FILE menu.

12-3-1. Structure for Backing Up Still and Clip Data

◆ Standard Backup Memory (MEM1-4) and USB Flash Drive for Backup

Four backup registers are provided as standard allowing still images to be saved.

If a USB memory stick is inserted into the switcher, all data including STILLS (still images and clip data) and INPUT_STILLS can be backed up.

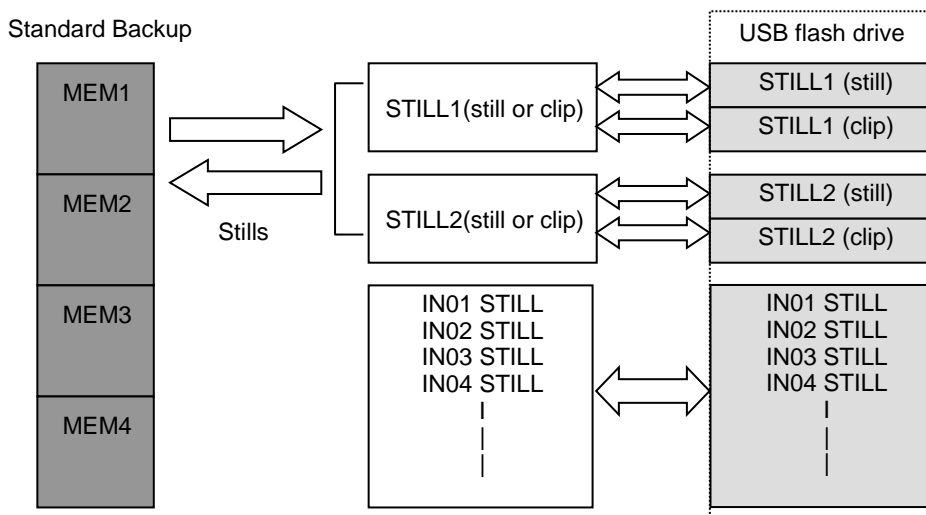

◆ Backup Folders in your USB Flash Drive

The following folders are automatically created in a USB flash drive when backing up through the USB flash drive.

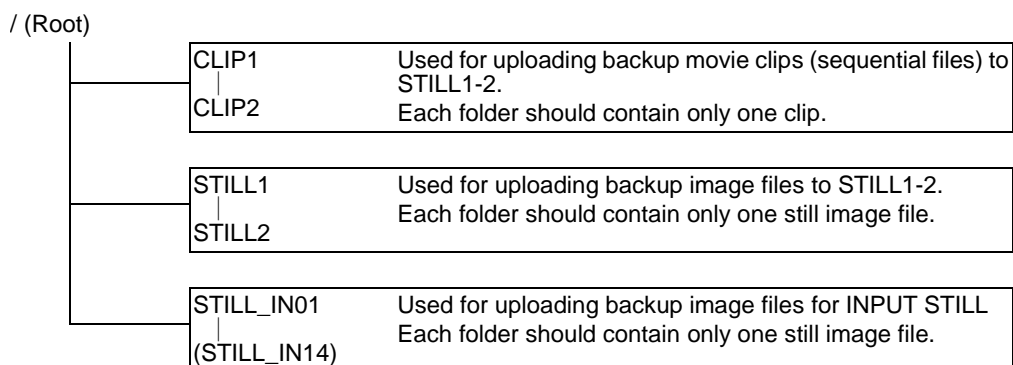

* If a subfolder in the USB stick is accidentally erased, set BACKUP to OFF then ON in the menu (see below). A new subfolder will be created.

12-3-2. Setting Automatic Backup to ON

- (1) Insert a USB memory stick for backup into the USB port on the switcher.
- (2) Press **MENU**, then **STILL** in the SELECT/KEYPAD block to open the [STILL] menu.
- (3) Go to PAGE 3.
- (4) Turn **F3** to set **BACKUP ON** to enable automatic backup. If set to **OFF**, backup is disabled.

STILL	:STILL	: FUNC	:BACKUP	:	: 3/6
BACKUP	:=STIL1	: <LOAD	: =ON	:	:

Automatic backup is enabled or disabled for **all** STILL, INPUT_STILL and CLIP images and **cannot** be set individually for each file.

12-3-3. Manually Loading Backup Data

- (1) Insert the USB memory stick in which the backup is stored into the USB port.
- (2) Go to [STILL] menu PAGE 3.
- (3) Turn **F1** to select a still, input still or clip to be backed up.
- (4) Turn **F2** to select **LOAD**. Then press **F2** to load the backup data.

STILL	:STILL	: FUNC	:BACKUP	:	: 3/6
BACKUP	:= STIL1	: < LOAD	: =ON	:	:

12-3-4. Deleting Backup Data

- (1) Insert the USB memory stick, in which the backup data is stored, into the USB port.
- (2) Go to [STILL] menu PAGE 3.
- (3) Turn **F1** to select a still, input still, clip or all data to be deleted.
- (4) Turn **F2** to select **DELETE**. Then press **F2** to delete the backup data.
If **ALL** is selected, all backup data will be cleared.

STILL	:STILL	: FUNC	:BACKUP	:	:	3/6
BACKUP	:= ALL	:< DELETE	: =ON	:	:	

12-3-5. Automatic Loading at Startup

- (1) Insert the USB memory stick, in which the backup data is stored, into the USB port.
- (2) Open [STILL] menu PAGE 2.
- (3) Turn **F1** to select a still or input still data to be loaded.
- (4) Turn **F4** to change **RESUME** to **BACKUP**. In the setting example below, backup data is automatically loaded from the USB flash drive to STILL1 at startup.

STILL	:STILL	: FUNC	:MEMORY	:RESUME	:	2/6
BACKUP	:= STILL1	: <LOAD	: =MEM1	:= BACKUP	:	

Which is loaded to Stills, a still image or movie clip?

For example, if **CLIP** is selected for STILL1 in [STILL] menu PAGE 1 as shown below, **clip** data will be loaded to STILL1. If **FRAME**, **ODD** or **EVEN** is selected, **still** data will be loaded.

STILL	:STILL1	:STILL2	:FIL SRC:KEY SRC:	1/6	
STORE	: > CLIP	: >FRAME:	=PGM	: =PGM	:

12-4. Transferring Image Files

The switcher can send and receive image data used for stills and video clips by connecting a PC through LAN (Ethernet). The FTP protocol is used to transfer files between the switcher and the computer. The switcher incorporates an FTP server.

12-4-1. LAN Connection

If you want to connect your computer and switcher to an existing LAN network, be sure to consult your network administrator before connecting, and use suitable cables and settings.

◆ Connecting to a PC

Connect the switcher to a computer with a LAN cable (UTP, Category 5 or higher). To connect the PC via a hub, use a **straight-through** cable. To **directly** connect to the PC, use a **cross-over** cable.

◆ Switcher Network Settings

Open the [SETUP - SYSTEM - ETHERNET] menu. The default settings for IP address, Net mask and Default Gateway are as shown below.

SYSTEM	:	IP ADDRESS	:	:	1/4
ETHERNET:	=	192.168.000.010	:	:	

SYSTEM	:	NET MASK	:	:	2/4
ETHERNET:	=	255.255.255.000	:	:	

SYSTEM	:	DEFAULT GATEWAY	:	:	3/4
ETHERNET:	=	192.168.000.001	:	:	

To Change IP Address, Net mask and Default Gateway

- (1) Open PAGE 1 in the menu.
 - (2) Press **F1**.
 - (3) The first octet (192 in the IP address example above) will be highlighted.
 - (4) Turn **F1** to change the number.
 - (5) Press **F1**.
 - (6) The second octet (168 in the IP address example above) will be highlighted.
 - (7) Repeat (4) and (5) for each octet to change the IP address.
 - (8) Reboot the main unit.
- ▶ See section 19-1. "Rebooting System."

MAC Address

The MAC address of the network card is displayed on PAGE 4.

SYSTEM	:	MAC ADDRESS	:	:	4/4
ETHERNET:		00-00-00-00-00-00	:	:	

◆ PC Requirements and Network Settings

An Ethernet port (100BASE-TX/1000BASE-T) and FTP client function are required for the personal computer. Any type of computer or OS can be used. In this section a Windows XP or 7-installed PC is used as an example.

Network Setting

IP Address	192. 168.0.10 (default)	Main unit
Subnet mask	255. 255. 255.0(default)	
IP Address	192. 168.0.1 to 192. 168.0.254 (Do not set the same IP as the main unit)	Computer
Subnet mask	255. 255. 255.0	

Refer to the procedure below to open the setting dialog and change the computer network settings, if necessary.

<Setting the IP Address in Windows XP>

Go to **Start > My Network Places**. Right-click **My Network Places**, and choose **Properties**. Right-click the **Local Area Connection** icon and choose **Properties**. Select the **Internet Protocol (TCP/IP)** check box, and click **Properties**.

<Setting the IP Address in Windows 7>

Go to **Start >> Control Panel >> Network and Internet >> Network and Sharing Center**, and then click **Change adapter settings**. Right-click the **Local Area Connection** icon and choose **Properties**. Click the **Internet Protocol Version 4(TCP/IPv4)** check box, and click **Properties**.

NOTE

The setting example above is for connecting the computer and switcher. Although the IP address of the switcher can be changed, the computer IP address should normally be changed.

▶ See section 12-4-1. "LAN Connection" for network settings in the switcher.

12-4-2. Image files

Image File Format: JPEG, TARGA and BITMAP

Image Size: Less than 1920 x 1080 [pixels]

File Name Format: (any file name).jpg, (any file name).tga and (any file name).bmp
Use the three-letter extension after the period. Any length of any characters can be used for file names.

▶ See "Appendix 1. Supported File Types" for details on the supported image files.

◆ **Still Directory Structure in the Main Unit**

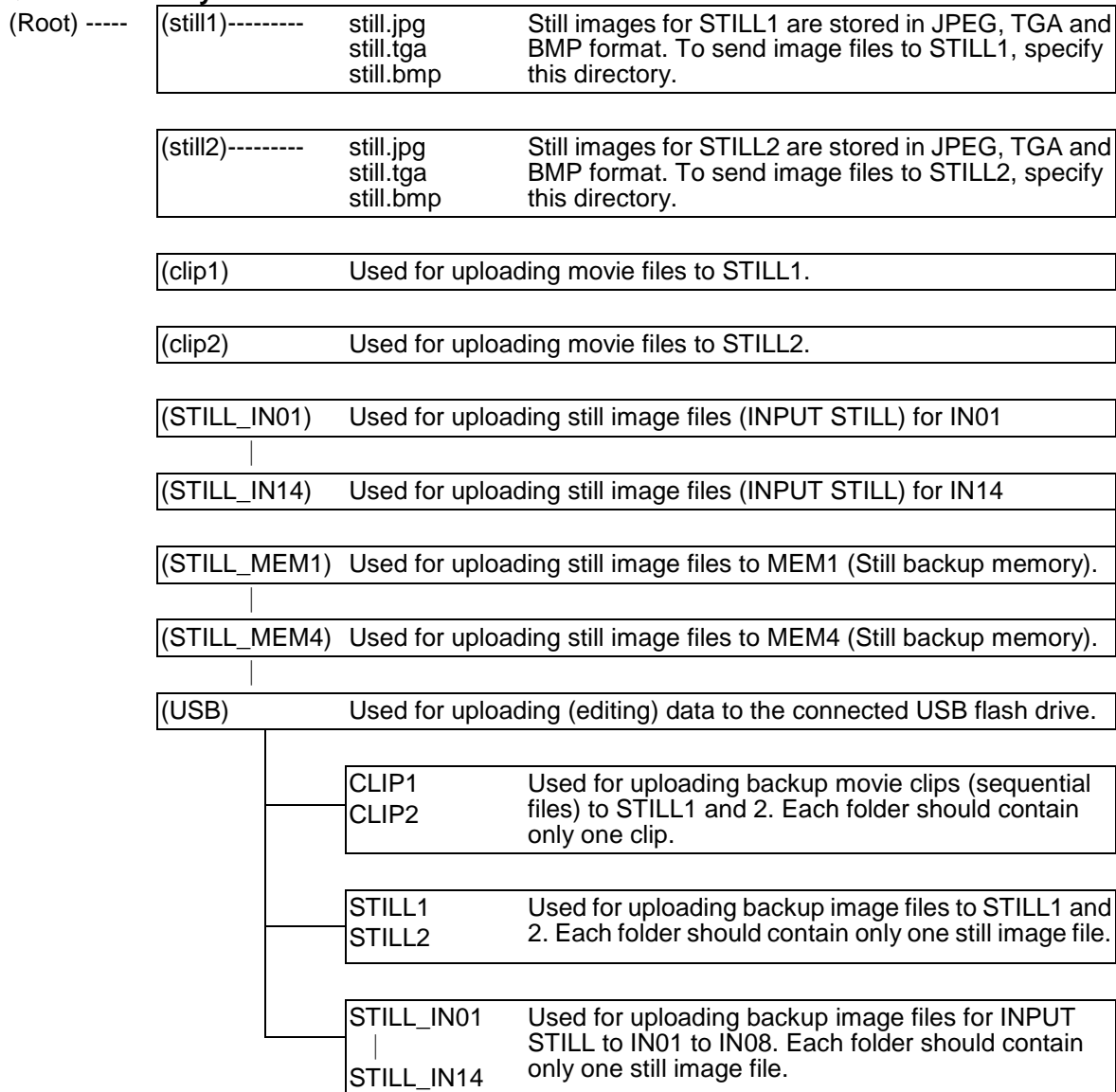

- * When uploading image or clip data to a sub folder in the connected USB flash drive, previous data in the folder must be removed.
- * If a subfolder in the USB flash drive is accidentally erased, set **BACKUP** to **OFF** then **ON**. A new subfolder will be created.
 - ▶ See section 12-3. "Backing-up Still and Clip Data (USB Flash Drive)."
- ▶ For still images, see section 12. "Still Store."
- ▶ For clip operations, see section 12-2. "Managing Clips."
- ▶ For INPUT STILL, see section 5-4. "INPUT STILL (Freezing Input Video)."
- ▶ For HVS-39MB, see section 12-3. "Backing-up Still and Clip Data (USB Flash Drive)."

12-4-3. Sending / Receiving Still Images

- (1) Connect the Ethernet ports on the PC and Main Unit directly using a LAN cross-over cable (UTP).

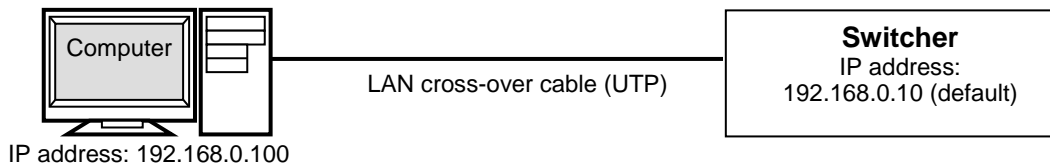

- (2) Click on the **Start** button, then on the **Control Panel** option.
- (3) Enable the passive mode as shown below.
 - (a) Click on **Network and Internet** (Windows 7) or **Network and Internet Connection** (Windows XP), then **Internet Options**.
 - (b) Click at the **Advanced** tab.
 - (c) Click to select the **Use Passive FTP (for firewall and DSL modem compatibility)** check box.
 - (d) Click **OK**.
- (4) Click on the **Start** button and then select **My Computer** (XP) or **Computer** (7).
- (5) Enter "**ftp://192.168.0.10**" in the address bar.
- (6) A dialog box appears and asks you to input username and password. Enter them as shown below.

Username: **hvsxt100** (Username cannot be changed.)
Password: **fora** (Password cannot be changed.)

- (7) Once you have accessed the FTP server, the following folders will be displayed in the window.

STILL1 and STILL2
CLIP1 and CLIP2
STILL-IN01 to STILL-IN14
STILL_MEM1 to STILL_MEM4

NOTE

Use PING or another network command to checking for any connection problems.

◆ Uploading Images to the Switcher

- (1) Open the folder in which your images are stored.
- (2) Drag and drop an image to be uploaded to a still folder (**STILL1** or **STILL2**) on the FTP server. The data transfer will take about 30 seconds to complete. Display the still image in the monitor, operating the switcher, to verify the still image has been properly sent.

◆ Downloading Still Images from the Switcher

Open a still folder (**STILL1** or **STILL2**) of the FTP server. Drag and drop an image file to be downloaded to any folder on your computer.

12-4-4. Sending Images to Clip Memory

◆ Preparation

(1) Prepare sequential image files in the following name format.

File name: [STILLXXX.yyy]

XXX: Indicates Serial numbers.
000 to 226 (1080/59.94i, 29.97PsF)
000 to 219 (1080/50i, 25PsF, 24PsF, 23.98PsF)
000 to 498 (720/59.94p, 50p)
000 to 998 (NTSC, PAL)

yyy: Indicates a file extension. **bmp, jpg or tga.**

WARNING: "STILL" must be in upper case.

(2) Connect to the PC, referring to steps (1) to (7) in the previous page.

◆ Uploading Sequential Images to Clip Memory in the switcher

(1) Open the folder on the PC, in which sequential files are stored.

(2) Drag and drop all sequential files to be uploaded to a clip folder (**CLIP1 or CLIP2**) on the FTP server. Sixty image files of data can be transferred in about 3 minutes.

12-5. CG WIPE

CG WIPE allows you to create a sequence in which a CG video, which is displayed using a KEY, moves in accordance with the motion of a WIPE or DVE pattern. CG WIPE patterns are usually modified according to sequences. To play CG wipes, the CG WIPE clip must be saved to a still buffer and a key channel is required for CG display.

◆ Fig. 1: CG WIPE Sequence Diagram with CG, Key and Background

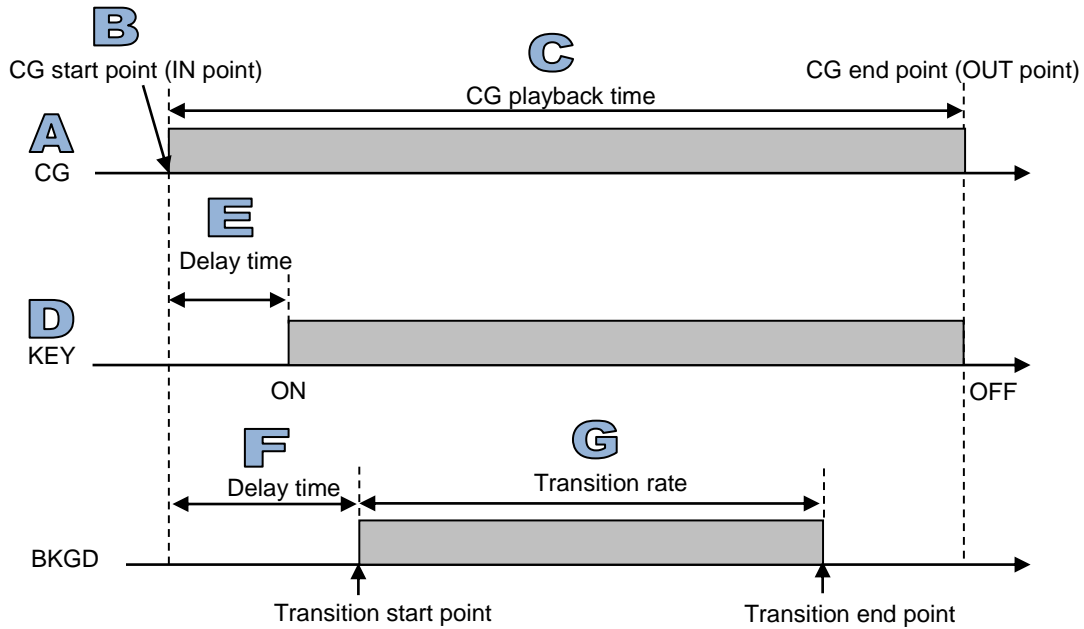

◆ Fig. 2: Example of CG WIPE Video

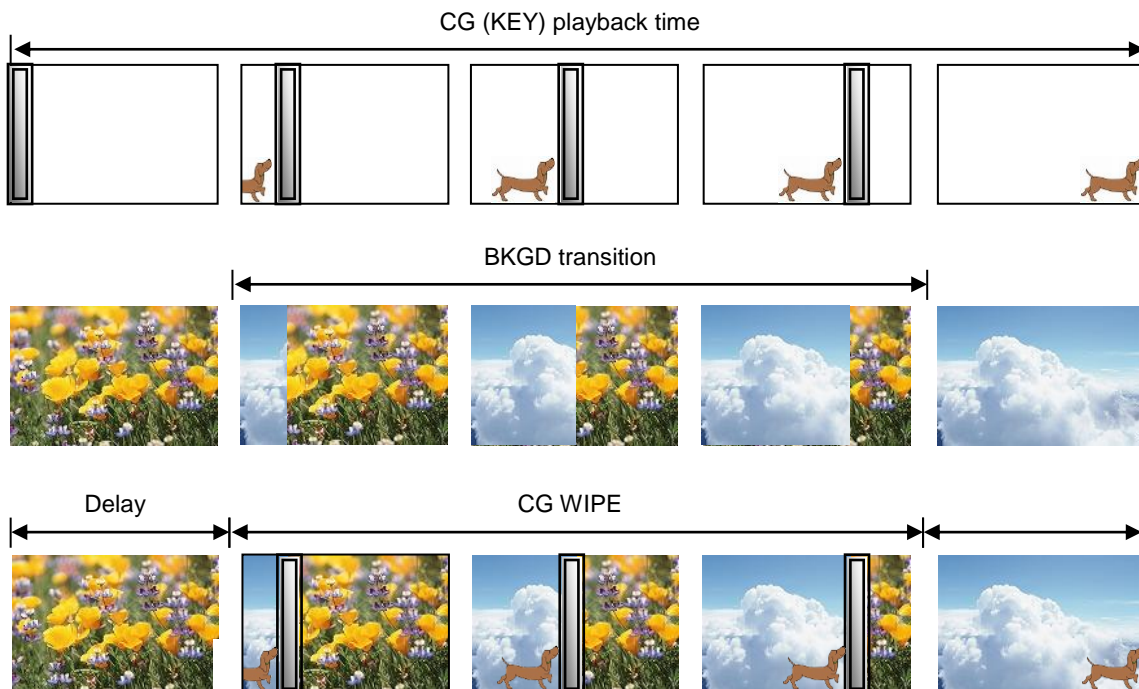

12-5-1. CG WIPE Operation Example 1

◆ Ex. 1: CG WIPE using STILL1 and KEY1

In this example, it is assumed that a CG (V + K) is stored in STILL1. Set IN/OUT points, and delay and transition rates, if necessary.

Assign STILL1 and STILL KEY to KEY1 signals, display KEY1 on the screen and play the CG through KEY1. Then set CG WIPE to ON, and perform a background transition. Adjust delay and transition rate values according to the CG WIPE sequence.

Setting up KEY

- (1) Display PAGE 1 in the [STILL] menu.
- (2) Set STILL1 to CLIP.
- (3) Double-press **KEY1** above the KEY/AUX bus to display the [KEY1 SETUP] menu.
- (4) Display the [KEY1 - INS/SRC] menu.
- (5) Set **TYPE** to **BUS**, **INSERT** to **STL1** (FILL) and **SOURCE** to **STK1** (KEY).

KEY1	:	TYPE	:	INSERT	:	SOURCE	:	INVERT	:	1/4
INS/SRC	:	=BUS	:	=STL1	:	=STK1	:	=OFF	:	

Setting up BKGD

- (1) Press **BKGD** in the transition block.
- (2) Press **WIPE** to set the BKGD transition type to **WIPE**. The [TRANS](1/6) menu is displayed.
- (3) Turn **F4** to select a desired pattern number. MIX, FAM and NAM (No. 200, 201 and 202) can also be used for CG WIPE.
- (4) Modify the selected pattern suitable for your CG WIPE sequence.

Setting up CG WIPE

- (1) Display the [WIPE] menu by pressing **MENU** then **WIPE** in the SELECT/KEYPAD block.
- (2) Display the [WIPE - CG WIPE] (1/3) submenu.
- (3) Set ENABLE to ON.
Select **STL1** under **CG**. (See **A** in Fig. 1, p. 130)
Set the CG playback time in frames under **DUR**. (See **C** in Fig. 1)

WIPE	:	ENABLE	:	CG	:		:	DUR	:	1/3
CG WIPE	:	=ON	:	=STL1	:		:	=30	:	

- (4) Go to PAGE 2 and select **KEY1** under **SELECT**. (See **D** in Fig. 1)
- (5) Set delay time in frames under **DELAY**, which indicates the duration from the start of CG playback (IN point) to the time when KEY1 is displayed on screen. (See **E** in Fig. 1)

WIPE	:	SELECT	:	DELAY	:		:		:	2/3
CG WIPE	:	=KEY1	:	=0	:		:		:	

- (6) Go to PAGE 3. Set the delay time in frames under **DELAY**, which indicates the duration from the start of CG playback to the transition start time. (See **F** in Fig. 1)
Set the background transition time under **RATE**. (See **G** in Fig. 1)

WIPE	:	DELAY	:	RATE	:	FDRLINK:	:		:	3/3
CG WIPE	:	=0	:	=30	:	=OFF	:		:	

Performing CG WIPE

- (1) Verify that the background transition type is set to **WIPE** and the modified **WIPE** pattern is properly selected. Use the fader lever or the **AUTO** button to perform a CG WIPE sequence.
- (2) Adjust time or position using the related menu items, as needed.

12-5-2. Saving CG WIPE Settings

CG WIPE settings can be saved as WIPE pattern modification settings in Direct Pattern and in the event memory.

- ▶ See section 8-8-3. "Direct Pattern Function"
- ▶ See section 15. "Event Memory."

12-5-3. CG WIPE Menu Quick Reference

- (1) Display the [WIPE] menu by pressing **MENU** then **WIPE** in the SELECT/KEYPAD block.
- (2) Turn **F1** to select **CG WIPE**. Press **F1** or the page down button to display the submenu pages.

WIPE	: ENABLE	: CG	:	:	DUR	:	1/3
CG WIPE	: =ON	: =STL1	:	:	=30	:	

WIPE	: SELECT	: DELAY	:	:		:	2/3
CG WIPE	: =KEY1	: =0	:	:		:	

WIPE	: DELAY	: RATE	: FDRLINK	:	:	:	3/3
CG WIPE	: =0	: =30	: =OFF	:	:	:	

◆ CG WIPE Parameters

Menu parameter	Default	Setting	Description	Fig. 1	
1/3	ENABLE	OFF	OFF, ON	Sets CG WIPE ON/OFF.	-
	CG	STL1	STL1-2	Selects a channel through which a CG is played back.	A
	DUR	30	0 to (clip duration)	Sets the CG playback time.	C
2/3	SELECT	KEY1	KEY1-2	Selects a KEY through which a CG is displayed.	D
	DELAY	0	0 to 255	Sets delay time from the start of CG playback (IN point) until the CG is displayed on screen (KEYER to ON).	E
3/3	DELAY (*1)	0	0 to 255	Sets delay time from the start of CG playback (IN point) to the start of transition.	F
	RATE (*1)	30	0 to 999	Sets the background transition rate.	G
	FDRLINK	OFF	ON, OFF	Sets if CG WIPE can be performed with the fader lever.	-

(*1) If the sum of the transition delay time and transition rate are longer than the CG playback time, the transition is forced to end immediately after the CG is finished playing and the image displayed on the monitor is switched to a PST image.

13. Multiviewer

The multiviewer function allows users to monitor multiple images such as video sources input to the switcher and internally generated or combined images on the same screen. The HVS-XT100 series switcher provides one channel output in 2/4/5/7/9/10/11/16 split screen formats. In addition, up to 8 layout patterns including video mapping can be saved and recalled. Video titles and on-air tally information can also be displayed. Note that the multiviewer outputs are delayed by one frame relative to the program output.

The setup procedure for the multiviewer is as follows :

1. Assign a multiviewer video to an output bus.
2. Select a split-screen type.
3. Video Signal Mapping
4. Add titles, audio level meters, safety area markers, on-air tallies and frame borders.

This chapter uses AUX2, 4-way screen, PGM, PREV, IN01 and IN02 display as examples.

13-1. Assigning the Multiviewer to an Output Bus

The multiviewer image can be assigned to any output bus (AUX, HDMI and additional outputs). There are two methods for multiviewer image assignment: using the buttons above the KEY/AUX bus or using the menu.

Let's output the Multiviewer image from AUX2.

◆ Using the Buttons above the KEY/AUX bus

- (1) Press **AUX2**.
- (2) Press **MV** in the KEY/AUX bus.

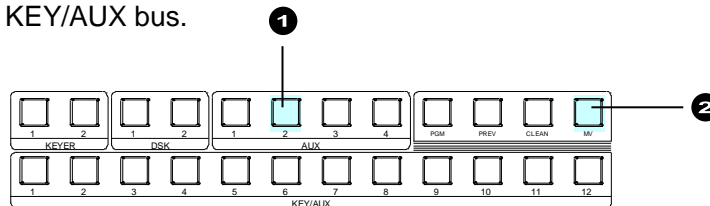

◆ Using the Menu

- (1) Double-press **AUX2** above the KEY/AUX bus.
- (2) The [SETUP - OUTPUT- OUT XPT] menu opens. Turn **F2** to select **MV**.

OUTPUT	: SELECT	: XPT	: TRANS RATE	: 1/3
OUT XPT	: =AUX2	: =MV	: En=OFF	=0 :

13-2. Selecting the Split-screen Type

Eight screen layout patterns can be selected using the [SETUP - OUTPUT - MV] menu.

- (1) Double-press **MV** in the KEY/AUX bus block to display the [SETUP - OUTPUT- MV] menu.
- (2) Turn **F1** to select **4** in this example.

OUTPUT	: DIV	<input type="text"/>	:	:	USER PRESET	: 1/7
MV	: = 4	<input type="text"/>	:	:	=OFF	>LOAD :

The available layout formats are 2, 4, 5, 7, 9, 10, 11 and 16-way as shown below.

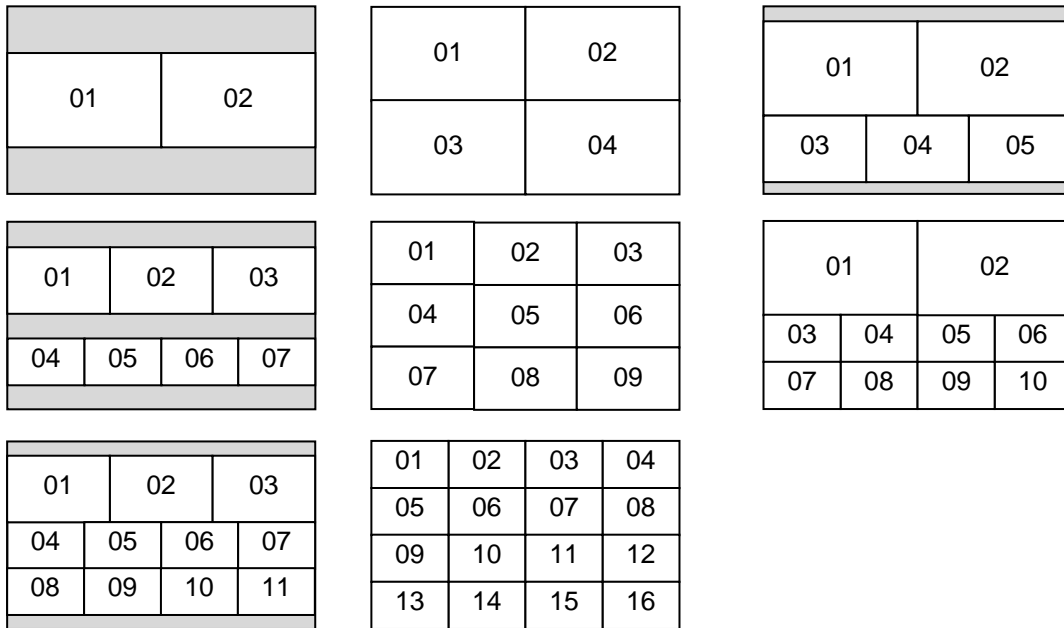

13-3. Video Signal Mapping

Let's assign PGM, PVW, IN01 and IN02 video signals to the set quad screen as shown below.



- (1) Double-press **MV** in the KEY/AUX bus block to display the [SETUP - OUTPUT - MV] menu.
- (2) Go to PAGE 2.
- (3) Turn **F1** to select a screen number under **SCREEN** and **F1** to select a video signal under **SIGNAL**. Repeat this step for four video signals as shown below.

```
OUTPUT : SCREEN : SIGNAL : CHARA : BRIGHT : 2/7
MV      : =1      : =IN01 : =SHORT: =10      :
```

```
OUTPUT : SCREEN : SIGNAL : CHARA : BRIGHT : 2/7
MV      : =2      : =IN02 : =SHORT: =10      :
```

```
OUTPUT : SCREEN : SIGNAL : CHARA : BRIGHT : 2/7
MV      : =3      : =PVW  : =SHORT: =10      :
```

```
OUTPUT : SCREEN : SIGNAL : CHARA : BRIGHT : 2/7
MV      : =4      : =PGM  : =SHORT: =10      :
```

Available video signals

Input images	IN01-IN14
Internal bus images	BLK(BLACK), STL1-STL2, STK1-STK2, CKFIL, CKKEY, MATT1, MATT2, CLBR(Color bar), EFF1, EFF2, PGM, PVW, CLN, AUX1-AUX8, CLOCK

13-4. Setting Up Each Split Area

13-4-1. Titles

- (1) Double-press the **MV** button in the KEY/AUX bus block to display the menu.
- (2) Go to PAGE2

```

OUTPUT : SCREEN : SIGNAL : CHARA : BRIGHT : 2/7
MV      : =1      : =PVW  : =SHORT: =10   :
    
```

Turn **F1** to select a screen number (split area).

Turn **F3** to select the type of title display. Short and long names can be used for titles.

CHARA setting	Description
OFF	Displays no title.
SHORT	Displays a title within 4 characters.
LONG	Displays a title within 8 characters.

Turn **F4** to change the title brightness.

Titles for input signals can be changed in the [SETUP - INPUT - RENAME] menu.

▶ See section 5-1. "How to Assign User Names to Sources."

Titles for output signals can be changed in the [SETUP - OUTPUT - RENAME] menu.

▶ See "Changing Output Signal Names" in the next page.

- (3) Press the page down button to go to PAGE 4.

```

OUTPUT : SCREEN : TITLE AREA/POSITION : 4/7
MV TITLE: = 1   : =NORML: X=  0: Y=-100 :
    
```

Turn **F1** to select a screen number (split area).

Turn **F2** to select the width of the title background.

Item	Description
WIDE	Spreads the title background to the width of the screen.
NORMAL(default)	Adjusts the width of the title background to fit the title.
OFF	Title Backgrounds are not displayed.

Turn **F3** and **F4** to adjust the horizontal and vertical title position.

Item	Description	
TITLE AREA POSITION	X	Selects the horizontal title position from -100 (left), 0 (middle) or 100 (right).
	Y	Selects the vertical title position from 100 (high), 0 (middle) or -100 (low).

◆ Setting Example

In this setting example, the multiviewer is set as shown on the right hand side with the multiviewer settings in the table below.

(Names are default settings.)

Screen number	SIGNAL setting	CHARA setting	WIDE/NORMAL selection
1	IN01	OFF	NORMAL
2	IN02	SHORT	
3	PVW	LONG	
4	PGM	LONG	

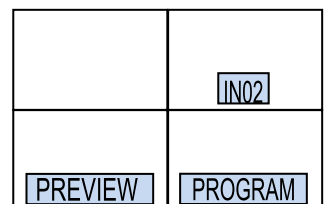

◆ Changing Output Signal Names

Open the [SETUP - OUTPUT - RENAME] menu and change names, as necessary.

OUTPUT	:SELECT	:SHORT	: LONG NAME (MV)	: 1/1
RENAME	: =PGM	: =PGM	: = PROGRAM	:

SELECT	SHORT (Default)	LONG NAME (Default)	Description
PGM	PGM	PROGRAM	M/E program outputs
PREV	PREV	PREVIEW	M/E preview outputs
CLN	CLN	CLEAN	M/E clean outputs
MEKEY	MEKY	M/E KEY	M/E program key outputs
AUX1 to AUX8	AUX1 to AUX8	—	AUX outputs

13-4-2. Audio Level Meter

A Level Meter for embedded audio can be displayed on each screen in multiviewer video. Select 2- or 4-channel for audio display which can be set for each screen.

- (1) Open PAGE 3 in the [SETUP - OUTPUT - MV] menu.
- (2) Turn **F1** to select a screen number.
- (3) Turn **F2** to select audio channels to be displayed.

OUTPUT	:SCREEN	:AUDIO	:SF AREA/SIZE	: 3/7
MV	: = 1	: = Ch1-4	: =OFF	:

AUDIO setting	Description
OFF	Displays no level meters.
Ch1/2, Ch3/4, Ch5/6, Ch7/8	Displays level meters for two channels.
Ch1-4, Ch5-8	Displays level meters for four channels.

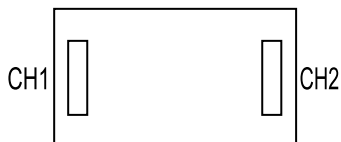

2-ch display example

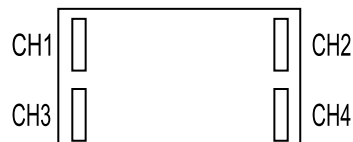

4-ch display example

13-4-3. Safety Area

- (1) Open PAGE 3 in the [SETUP - OUTPUT - MV] menu.
- (2) Turn **F1** to select a screen number.
- (3) Turn **F3** to select **OFF**, **HOOK** or **BOX** the safety area display. (Selectable for each screen)
 - ▶ See section 6-7. "Safety Area Markers" for details on safety area display.
- (4) Turn **F4** to select the safety area size.

OUTPUT	:SCREEN	:AUDIO	:SF AREA/SIZE	: 3/7
MV	: = 1	: =Ch1-4:	= HOOK	: = 70%

13-4-4. Frame Border

Frame borders can also be applied to the split-screen to emphasize channel areas.

- (1) Open PAGE 5 in the [SETUP - OUTPUT - MV] menu.
- (2) Turn **F4** to select a border color among eight standard colors. Press **F4** to apply the selected color. If you want to adjust the selected color or initially set the color, set the HSL values.
 - ▶ See section 5-9-1. "Setting the Matte Color."

OUTPUT	:	BORDER COLOR	:	RECALL	:	5/7
MV BDR	:	S=0.0 L=100.0 H=0.0	:	>WHITE:		

13-4-5. On-air Tally

Tallies indicate which video is currently On-air (output from the program) and which is set to be the next output. The multiviewer can display two types of tally indicators: Frame and Marker. You can use either or both at the same time.

- (1) Open PAGE 6 in the [SETUP - OUTPUT - MV] menu.
- (2) Select a tally indication. Frame (FRAME) and square (MARKER) markers can be displayed at the same time.

OUTPUT	:	FRAME	:	MARKER	:	KEY TLY	:	6/7
MV TALLY	:	=ON	:	=ON	:	=ON	:	

◆ Setting Example

Here, we assume that IN02 is displayed in the PGM screen and IN01 is selected on the PST bus. The tally frame and marker are displayed on the screen. (See the menu above.)

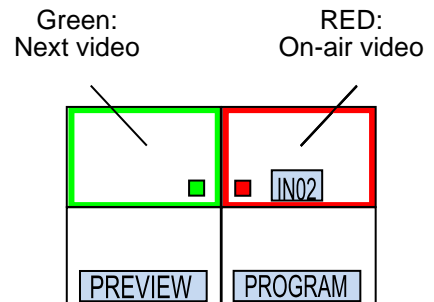

◆ KEY TALLY

Note that the "Key-On tally" information is included in the tally data as factory default. If you need only "Background -On" tallies, set **KEY TLY** to OFF.

IMPORTANT	
<p>On-air tally indications (RED and GREEN) are linked to the tally color settings (TLY COL). For example, if the PGM tally color is set to RED and the PST tally color to NONE, the green tally (next indication) is not displayed on screen.</p> <p>▶ See section 20-1-2. "Pin Assignment Examples"- "Tally Outputs."</p>	

◆ TALLY LINK

Another tally indication can be displayed on a multiviewer image screen. For example, to display the IN05 tally indication on the IN06 video screen of the multiviewer, set parameters as shown below in PAGE 7. Setting **LINK EN** to ON to enable all tally links set in this menu.

OUTPUT	:	TALLY LINK	:	LINK EN	:	7/7
MV TALLY	:	SRC=IN06 LINK=IN05	:	=ON	:	

13-5. Saving / Loading Screen Layouts

Up to eight screen layout patterns can be saved to / loaded from the [SETUP - OUTPUT - MV] menu.

13-5-1. Saving a Screen Layout

- (1) Open PAGE 1 in the [SETUP - OUTPUT - MV] menu.
- (2) Turn **F3** to select the memory number.
- (3) Turn **F4** to select **SAVE** and press **F4**. The current layout settings are saved to the selected memory number.

OUTPUT	:	DIV	<input type="text"/>	:	:	USER PRESET	:	1/7
MV	:	= 4	<input type="text"/>	:	:	= U1	> SAVE	:

13-5-2. Loading a Screen Layout

- (1) Open PAGE 1 in the [SETUP - OUTPUT - MV] menu.
- (2) Turn **F3** to select the memory number.
- (3) Turn **F4** to select **LOAD** and press **F4**. The screen layout will be loaded.

OUTPUT	:	DIV	<input type="text"/>	:	:	USER PRESET	:	1/7
MV	:	= 4	<input type="text"/>	:	:	= U1	> LOAD	:

13-5-3. Deleting Screen Layout Data

- (1) Open PAGE 1 in the [SETUP - OUTPUT - MV] menu.
- (2) Turn **F3** to select the memory number.
- (3) Turn **F4** to select **DEL** and press **F4**. The memory data will be deleted.

OUTPUT	:	DIV	<input type="text"/>	:	:	USER PRESET	:	1/7
MV	:	= 4	<input type="text"/>	:	:	= U1	> DEL	:

14. USER Buttons

User buttons can be assigned to specific menu pages and used as shortcuts or specific functions buttons. Follow the procedure below to assign the desired menu page or function to buttons.

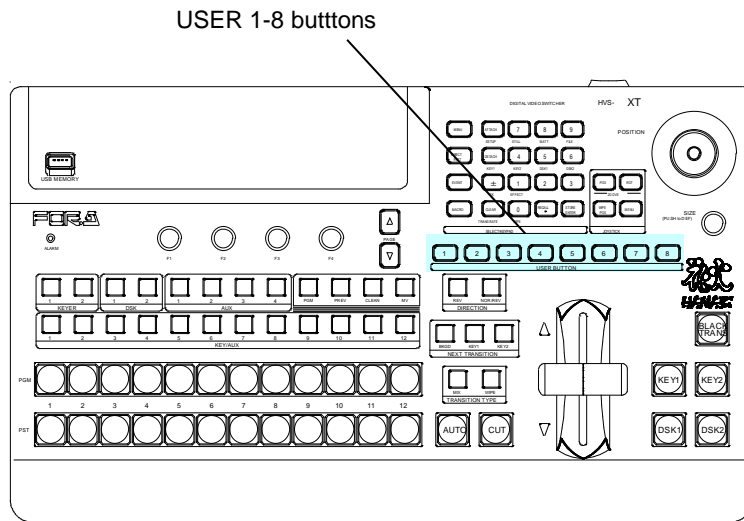

14-1. USER Button Operation

- (1) Press **MENU** in the SELECT/KEYPAD block, then press **SETUP** to display the SETUP top menu.
- (2) Turn **F1** to select **PANEL**, then press **F1** to open the [SETUP - PANEL] menu.
- (3) Turn **F1** to select **USER BTN**, then press **F1** to open the [SETUP - PANEL - USER BTN] menu.
- (4) Turn **F1** to select a user button. The user button will blink.
- (5) Turn **F2** to select a type.

To Assign Menu Pages:

- Turn **F2** to select **MENU**, then press **F2**.
- Turn **F3** to select a menu page, then press **F3**.
- ▶ See the next page for available menu pages.

USER	:SELECT	: TYPE	: FUNC(F3)	: 1/2
BUTTON	: =OU-1	: =MENU	: =FILE LOAD MENU	

In the example above, the [FILE-LOAD] menu page is assigned to USER 1. Pressing USER1 directly opens the menu page.

To Assign Other Functions:

- Assign a function to a user button in the same way as those for menu pages above.
- ▶ See the following pages for available types and functions.

USER	:SELECT	: TYPE	: FUNC(F3)	: 1/2
BUTTON	: =OU-2	: =USTRS:	=DSK1 SCALER	

In the example above, DSK1 SCALER (execute transition) is assigned to USER 2.

◆ **Assignable Menu Page**

Setting (Accessed menu page)	
FILE TOP MENU	DSK1-2 MATT MENU
FILE LOAD MENU	DSK1-2 GAIN/CLIP MENU
FILE SAVE MENU	DSK1-2 POS/SIZE MENU
SYSTEM-FORMAT MENU	DSK1-2 CROP MENU
EDITOR MENU	DSK1-2 BORDER MENU
MV MENU	AUTO CK MENU
STATUS MENU	STILL MENU
KEY1-2 EDGE MENU	MATT MENU
KEY1-2 MATT MENU	VTR /VDCP MENU
KEY1-2 GAIN/CLIP MENU	TRANS LIMIT MENU
KEY1-2 POS/SIZE MENU	
KEY1-2 CROP MENU	
KEY1-2 BORDER MENU	

◆ **Assignable Functions**

Once a function is assigned to a User button, pressing the button switches the assigned function On and Off. If a function is assigned, it can also be a menu shortcut (accessible by Double-pressing the button).

When MARKR (Marker) is selected for TYPE:		
Setting	Function	Button Indication
XT100	AUX1-4 ENABLE	Pressing the button shows a safety area marker for the output.
XT110	AUX1-8 ENABLE	
HDMI ENABLE		
XT100	SLOT-B CH1-2 ENABLE SLOT-C CH1-2 ENABLE	

When GPIO (GPI In/Out) is selected for TYPE:		
Setting	Function	Button Indication
GPI IN ENABLE	Pressing the button enables GPI IN.	ON: Lit orange, OFF: Lit white
GPI OUTPUT1-8 (PUSH)	The GPI OUTPUT function (1-8) represents the ON/OFF setting for each GPI OUTPUT (1-8) assigned to a GPI IN/TALLY OUT connector pin that is set at the menu. The function is enabled whenever the relevant USER button is pressed.	Lit orange when pushed, Unless lit white.
GPI OUTPUT1-8 (TGLE)	The GPI OUTPUT function (1-8) represents the ON/OFF setting for each GPI OUTPUT (1-8) assigned to a GPI IN/TALLY OUT connector pin that is set at the menu. The function is enabled or disabled each time the relevant USER button is pressed.	ON: Lit orange, OFF: Lit white

When USTRS (User Transition) is selected for TYPE:		
Setting	Function	Button Indication
KEY [DSK] 1-2 SCALER	Performs the user transition for KEY1-2 and DSK1-2.	Displayed: Lit red Displayed on AUX bus (DSK only): Lit green
KEY [DSK] 1-2 MIX		
KEY [DSK] 1-2 SLIDE LEFT		
KEY [DSK] 1-2 SLIDE RIGHT		
KEY [DSK] 1-2 SLIDE TOP		
KEY [DSK] 1-2 SLIDE BOTTOM		Not displayed: Lit white
KEY [DSK] 1-2 WIPE LEFT		
KEY [DSK] 1-2 WIPE RIGHT		
KEY [DSK] 1-2 WIPE TOP		
KEY [DSK] 1-2 WIPE BOTTOM		

When KEYER is selected for TYPE:		
Setting	Function	Button Indication
KEY [DSK] 1-2 2D DVE ENABLE	Sets 2D DVE On/Off.	ON: Lit orange, OFF: Lit white
KEY [DSK] 1-2 BOX MASK AND ENABLE	Sets AND type BOX MASK On/Off.	
KEY [DSK] 1-2 BOX MASK OR ENABLE	Sets OR type BOX MASK On/Off.	
KEY1-2 EDGE NORMAL ENABLE	Sets Normal Edge On/Off.	
KEY1-2 EDGE OUTLINE ENABLE	Sets Outline Edge On/Off.	
KEY[DSK] 1/2 PRIORITY	Changes KEY or DSK layers. ▶ See section 9-5. "Changing KEY or DSK Layer Order."	
PREVIEW KEY [DSK] 1-2 ENABLE	Sets keys On or Off for preview outputs.	

When VTR is selected for TYPE (planned for future support):		
Setting	Function	Button Indication
VTR/VDCP REW	Operates the VTR or VDCP channel. The VTR or VDCP to be controlled can also be selected under VTR1 SELECT , VTR2 SELECT , VDCP1 SELECT or VDCP2 SELECT below.	During execution: Lit orange,, Other cases: Lit white
VTR/VDCP PLAY/PAUSE		During play: Lit green Other cases: Lit white
VTR/VDCP FWD		During execution: Lit orange,, Other cases: Lit white
VTR/VDCP STOP		Always lit orange
VTR/VDCP REC		During execution: Lit orange,, Other cases: Lit white
VTR/VDCP STEP REV		Always lit white
VTR/VDCP STEP FWD		
VDCP MARK IN		
VDCP MARK OUT		
VDCP TC DISPLAY		Displays time code information when controlling VDCP devices.
VTR1-2 SELECT	Selects a VTR or VDCP channel for control. Selecting the channel again deselects it.	Channel selected: Lit orange Other cases: Lit white
VDCP1-2 SELECT (*1)		
VTR1-2 REW	Rewinds video on VTR1-2.	During execution: Lit orange,, Other cases: Lit white
VTR1-2 PLAY	Plays video on VTR1-2.	During play: Lit green Other cases: Lit white
VTR1-2 PAUSE	Pauses video on VTR1-2.	Always lit white
VTR1-2 FWD	Fast-forwards video VTR1-2.	During execution: Lit orange,, Other cases: Lit white
VTR1-2 STOP	Stops recoding/playback on VTR1-2.	Always Lit white
VTR1-2 REC	Records video on VTR1-2.	During execution: Lit red,, Other cases: Lit white
VTR1-2 GOTO TOP	Cues to 00:00:00:00 on VTR1-2	Always Lit white
VDCP1-2 REW	Rewinds video on VDCP1-2.	During execution: Lit orange,, Other cases: Lit white
VDCP1-2 PLAY	Plays video on VDCP1-2.	During play: Lit green,, Other cases: Lit white
VDCP1-2 PAUSE	Pauses video on VDCP1-2.	Always lit white
VDCP1-2 FWD	Fast-forwards video VDCP1-2.	During execution: Lit orange,, Other cases: Lit white
VDCP1-2 STOP	Stops recoding/playback on VDCP1-2.	Always lit white
VDCP1-2 REC	Records video on VDCP1-2.	During execution: Lit red, Other cases: Lit white
VDCP1-2 GOTO TOP	Cues to 00:00:00:00 on VDCP1-2	Always lit white

When STILL is selected for TYPE:		
Setting	Function	Button Indication
STILL1-2 STORE	Performs still captures.	Always lit orange
INPUT01-14 STILL STORE	Captures and saves or clears a still image for INPUT STILL 1 to 14.	Image stored: Lit orange, Image not stored: Lit white
INPUT STILL STORE	Captures and saves or clears a still image for INPUT STILLs using KEY/AUX bus ▶ See section 5-4. "INPUT STILL."	Lit orange when pressed
CLIP 1-2 PLAY/PAUSE	Begins to play the recorded clip or pauses the playback/recording.	During play: Lit green Other cases : Lit white
CLIP 1-2 STOP	Stops clip playback and cues to IN point.	During stop: Lit orange Other cases : Lit white
CLIP 1-2 REC	Begins to record video	During recording: Lit red Other cases : Lit white

When AUX is selected for TYPE:		
Setting	Function	Button Indication
AUX5-8 XPT SELECT	Allows the AUX output signal to be selected using the KEY/AUX bus buttons.	ON: Lit orange OFF: Lit white
AUX1-8 TRANS ENABLE	Sets AUX crossfade transition On/Off.	
AUX LINK ENABLE	Enables all AUX links.	

When OTHER is selected for TYPE:		
Setting	Function	Button Indication
EDITOR ENABLE	Sets editor control On/Off.	ON: Lit orange OFF: Lit white
WIPE MOD RESET	Resets the [WIPE] menu.	Always lit white
CG WIPE ENABLE	Enables CG WIPE.	ON: Lit orange OFF: Lit white
ROUTER ENABLE	Enables router control.	ON: Lit orange OFF: Lit white
SUBEFF1-2 FLD FREEZE	Enables FIELD FREEZE in a Sub Effect channel.	ON: Lit orange OFF: Lit white
SUBEFF1-2 FRM FREEZE	Enables FRAME FREEZE in a Sub Effect channel.	ON: Lit orange OFF: Lit white
ASSIGN INHI ENABLE	Enables the bus button inhibit function.	ON: Lit orange OFF: Lit white
FS ENABLE	Enables frame synchronization for each input using the KEY/AUX bus. ▶ See section 5-7. "Frame Synchronizer."	ON: Lit orange OFF: Lit white
JOY-STICK FINE	Enables fine control of the joystick.	ON: Lit orange OFF: Lit white
EVENT NO.00-09 RECALL	Loads an event.	Event stored: Lit orange Event not stored: Lit white
MACRO BUS SELECT	Sets the KEY/AUX bus to Macro mode. To exit the Macro mode, press a bus selection button (KEY1-2, DSK1-2 or AUX1-4). ▶ See section 16-4-1. "Changing KEY/AUX Bus Buttons to Macro EXE Buttons."	ON: Lit orange OFF: Lit white

14-2. Triggering User Buttons

User buttons can be triggered (activated) by state changes (ON/OFF) in tally or GPI function items. This chapter shows how to set settings for these examples in the USER BUTTON menu. Three typical examples are shown below:

- Ex. 1: **Starts KEY1 SCALER transitions** when **IN01 is displayed** on the **PGM** screen.
- Ex. 2: **Starts KEY2 MIX transitions** when **IN01 is cleared** from the **PGM** screen.
- Ex. 3: **Plays video on VTR1** when **KEY1 is ON**.

<Ex. 1>

To execute the Ex. 1 procedure using USER Button 1, set the menu as shown below.

- (1) Open PAGE 1 of the [USER BUTTON] menu.
- (2) Select **OU-1** for SELECT, **USTRS** for TYPE and **KEY1 SCALER** in the next field.

USER	:SELECT	: TYPE	: FUNC(F3)	: 1/2
BUTTON	: =OU-1	: =USTRS	: =KEY1 SCALER	

- (3) Press the page down button to go to PAGE 2.
- (4) Turn **F3** to select **RED TALLY-IN01**. Set TRG EDG to **ON**.

USER	:SELECT	:TRG EDG:	FUNCTION(F3)	: 2/2
BUTTON	: =OU-1	: =ON	: =RED TALLY-IN01	

<Ex. 2>

To execute the Ex. 2 procedure using USER Button 2, set the menu as shown below.

- (1) Set PAGE 1 of the [USER BUTTON] menu as shown below.

USER	:SELECT	: TYPE	: FUNC(F3)	: 1/2
BUTTON	: =OU-2	: =USTRS	: =KEY2 MIX	

- (2) Set PAGE 2 as shown below. (See the table on the next page for details on TRG EDG.)

USER	:SELECT	:TRG EDG:	FUNCTION(F3)	: 2/2
BUTTON	: =OU-2	: =OFF	: =RED TALLY-IN01	

<Ex. 3>

To execute the Ex. 3 procedure using USER Button 3, set the menu as shown below.

- (1) Set items on PAGE 1 of the [USER BUTTON] menu as shown below.

USER	:SELECT	: TYPE	: FUNC(F3)	: 1/2
BUTTON	: =OU-3	: =VTR	: =VTR1 PLAY	

- (2) Set items on PAGE 2 as shown below.

USER	:SELECT	:TRG EDG:	FUNCTION(F3)	: 2/2
BUTTON	: =OU-3	: =ON	: =KEY1 ON TLY	

◆ **About TRG EDG (TRIGGER EDGE)**

Setting	Description
ON (Default)	User button function is activated when the state of the specified item changes to ON.
OFF	User button function is activated when the state of the specified item changes to OFF.
DBL	User button function is activated when the state of the specified item changes to ON or OFF.

◆ **About FUNCTION**

The FUNCTION parameter specifies an item as a trigger.

▶ See section 20-1-4. "GPI / Tally Function List" for details.

NOTE

The following User Button functions cannot be activated by triggers.

-Record on VTR or VDCP (if DIRECT REC mode is off.)

-Record to Clip Memory (if REC MODE is STANDARD.)

15. Event Memory

The switcher can save control panel setup states as data for recall when needed. This function is called Event Memory. This Event Memory function enables quick recall of previously saved setting states. The event memory data can accurately reproduce panel settings and selections including pattern modification and key setup, because the event memory data holds all panel information.

The keypad is used to save and recall events. The event memory data can be backed up and then restored from USB flash drives.

▶ See section 17 "File Operation."

In addition, the RATE parameter in the EVENT menu allows users to perform transitions by loading events.

▶ See section 15-5. "Transitions Using Event Recall."

15-1. Storing Events

The event memory can store control panel setting states. Up to 100 events (10 memory pages, with 10 events per page) can be stored in memory.

This chapter explains how to save the current panel settings to an event, **EVENT 12** (PAGE1, Number Button 2) as an example.

(1) Press **EVENT** in the SELECT/KEYPAD block.

The [EVENT MEMORY] menu is displayed and the keypad switches to EVENT mode.

(2) Turn **F1** to select **1** (PAGE 1) in the [EVENT MEMORY] menu.

EVENT	:	PAGE	:	DIRECT	:	PAGECLR:	RATE	:	1/2	
MEMORY	:	= 1	:	=OFF	:	>CRNT	:	=OFF	:	L=0

(3) Press **STORE** on the keypad.

(4) Press **2** on the keypad to store the event.

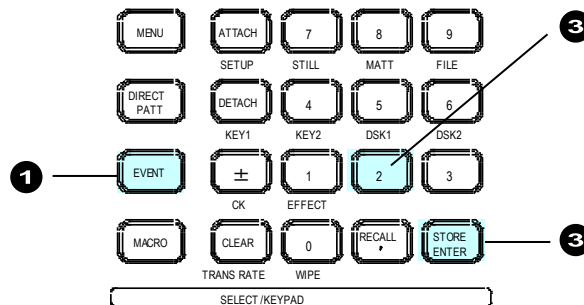

If an Event is Already Saved to **2** on the Keypad:

If **2** on the keypad lights green after **STORE** is pressed, an event is already saved to the event number (EVENT 12). Press **2**. It will flash.

- To overwrite the existing data, press **2** again.
- To cancel the operation, press **STORE**.
- To save the data to another button, press a lit white number button.

If you cannot overwrite data (the button is lit red), cancel the process by pressing **STORE**, then change **OVER WR** to **ENABL** (ENABLE) in the [EVENT RECALL] menu. The menu is automatically displayed when pressing an event-stored button

15-2. Recalling Events

Let's load EVENT 12 (PAGE1, Number Button 2) saved in the previous page to the control panel.

- (1) Press **EVENT** in the SELECT/KEYPAD block.
The [EVENT MEMORY] menu is displayed and the keypad switches to EVENT mode.
- (2) Turn **F1** to select 1 (PAGE 1) in the [EVENT MEMORY] menu.
Turn **F2** to set **DIRECT** to **ON** to change the mode to DIRECT RECALL.

```
EVENT  : PAGE  :DIRECT :PAGECLR:  RATE  : 1/2
MEMORY : =1      : =ON   : >CRNT  : =OFF  : L=0
```

- (3) Press **2** on the keypad. EVENT 12 will be loaded to the control panel. Last Recall No.

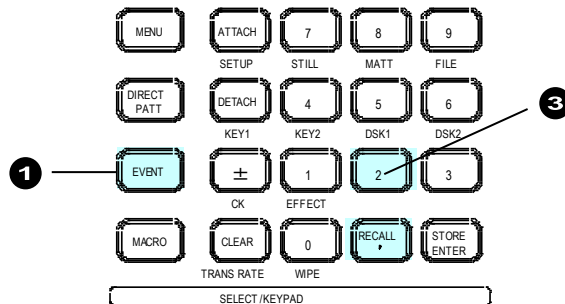

The number of the last recalled event is displayed at bottom right in the [EVENT MEMORY] menu. This indication is useful when checking which event was recalled last.

◆ If DIRECT RECALL is Disabled:

If **DIRECT** is set to **OFF** in the [EVENT MEMORY] menu, you need to press **RECALL** after pressing **2** on the keypad to recall the event.

◆ Selecting Data to be Loaded

If **DIRECT** is set to **OFF** in the [EVENT MEMORY] menu, you can select the data to be loaded in all settings saved in the event.

Now, let's recall EVENET12 (PAGE1, Number Button 2) again, but **without** loading **KEY1 settings**.

- (1) Press **EVENT** in the SELECT/KEYPAD block.
- (2) Select 1 (PAGE 1) in the [EVENT MEMORY] menu. Set **DIRECT** to **OFF**.
- (3) Press **2** on the keypad. The [EVENT RECALL] menu will be displayed.
- (4) Turn **F1** to select **KEY1**. Set both **XPT** and **DATA** to **OFF**.

```
EVENT  :SELECT : XPT   : DATA  : RATE  : 1/3
RECALL : =KEY1  : =OFF  : =OFF   : =OFF  : P.00
```

Page No.

- (5) Press **RECALL**. A beep will sound and the settings in EVENT 12, excluding KEY1 settings, are loaded to the control panel.

► Data can also be selected when storing to events. See 15-4. "Event Data " for details.

15-3. Protecting / Deleting Event Data

This chapter sets write protection on EVENT 12 as an example. The data can be deleted from EVENT 12 in the same menu page.

- (1) Press **EVENT** in the SELECT/KEYPAD block to display the [EVENT MEMORY] menu.
- (2) Select **1** (PAGE 1) in the [EVENT MEMORY] menu.
(Set **DIRECT** to **OFF**, so that EVENT 12 is not recalled when pressing the button.)
- (3) Press **2** on the keypad. The [EVENT RECALL] menu will appear.
- (4) Go to PAGE 3.
- (5) Turn **F2** to change **OVER WR** to **DISBL**(disable) to set write protection on EVENT 12.

EVENT	:	OVER WR	:	DELETE	:		:	3/3
RECALL	:	=DISBL	:	>OFF	:		:	P.01

To delete data from **EVENT 12**, turn **F2** to set **DELETE** to **ON**, then press **F2**.

EVENT	:	OVER WR	:	DELETE	:		:	3/3
RECALL	:	=OFF	:	>ON	:		:	P.01

◆ To Delete Data for an Event Page:

- (1) Press **EVENT** in the SELECT/KEYPAD block to display the [EVENT MEMORY] menu.
- (2) Turn **F1** to select an event page to be deleted.
- (3) Turn **F3** to set **PAGECLR** to **CRNT** (current), then press **F3**. The data saved in the event page will then be cleared.

EVENT	:	PAGE	:	DIRECT	:	PAGECLR	:	RATE	:	1/2
MEMORY	:	=1	:	=OFF	:	>CRNT	:	=OFF	:	L=10

◆ To Delete All Event Data :

- (1) Press **EVENT** in the SELECT/KEYPAD block to display the [EVENT MEMORY] menu.
- (2) Set **PAGECLR** to **ALL**, and press **F3**. All event data is cleared.

EVENT	:	PAGE	:	DIRECT	:	PAGECLR	:	RATE	:	1/2
MEMORY	:	=0	:	=OFF	:	>ALL	:	=OFF	:	L=10

15-4. Event Data

15-4-1. Data Not Saved in Events

All SETUP menu settings
 All FILE menu settings
 STILL images
 ADV CTRL settings in the TRANS menu (See section 8-10-1.)

15-4-2. Detailed Data Selection for Saving Events

When **[STORE]** is pressed while storing events, the **[EVENT STORE]** menu is displayed and data to be saved to the event can be selected in the menu as shown below.

EVENT	:SELECT	:XPT	:DATA	:RATE	: 1/2
STORE	: =ALL	: =ON	: =ON	: =OFF	: P.00

EVENT	:AUX SEL	:AUX RCL	:DSK ASG	:CG WIPE	: 2/2
STORE	: =ALL	: =OFF	: =OFF	: =OFF	: P.00

[EVENT STORE] menu

Item	Setting (*1)	Description
SELECT	ALL , BKGD (*2), KEY1-KEY2, DSK2-DSK2, CK, EFF	To select bus data, select ALL or a bus under SELECT then set ON (default) or OFF under XPT and DATA . All bus data (signal selection transition rate, transition type settings, etc.) is stored as factory default settings. If set DATA to ON and XPT to OFF: All data for the bus excluding the signal selection is saved to events. If set DATA to OFF and XPT to OFF: No data for the bus is saved to events.
XPT	ON , OFF	
DATA	ON , OFF	
*RATE	OFF , 1-999	See section 15-5. "Transitions Using Event Recall."
AUX SEL	ALL , AUX1-AUX8	Select an AUX bus at AUX SEL .
AUX RCL	ON, OFF	Setting AUX RCL to ON stores the information for the bus.
*DSK ASG	ON, OFF	Setting to ON stores the output bus where DSK1 and DSK2 images appear. ► See section 8-5-1. "Where DSK Images Appear."
*CG WIPE	ON, OFF	Setting to ON stores the current CG WIPE data.

* Indicates the same item in both [EVENT MEMORY] and [EVENT STORE] menus.

(*1) Default settings are displayed in bold text . Default settings can be changed. (See the next page.)

(*2) The **MATT** menu settings are saved under **BKGD**

IMPORTANT

User Default Settings for the [EVENT STORE] menu

The same parameters (RATE, KEY ASG and CG WIPE) in the [EVENT MEMORY] and [EVENT STORE] menus link together. When one is changed in the [EVENT MEMORY] menu, it is also changed in the [EVENT STORE] menu and becomes the default setting in the [EVENT STORE] menu, but not vice versa.

► See section 15-4-3. "Setting the User Default Menu when Storing an Event."

15-4-3. Setting the User Default Menu when Storing an Event

The [EVENT STORE] menu appears as shown below in the factory default setting when storing events.

EVENT	:SELECT	: XPT	: DATA	: RATE	: 1/2
STORE	: =ALL	: =ON	: =ON	: =0	: P.00

EVENT	:AUX SEL	:AUX RCL	:DSK ASG	:CG WIPE	: 2/2
STORE	: =ALL	: =OFF	: =OFF	: =OFF	: P.00

Changing the default setting of the [EVENT STORE] menu is possible. To do this, proceed as follows.

- (1) Press **EVENT** in the SELECT/KEYPAD block to display the [EVENT MEMORY] menu.
- (2) Change the following menu items to the desired settings, which become the default settings in the [EVENT MEMORY] menu. (Only highlighted items are changeable.)

EVENT	: PAGE	:DIRECT	:PAGECLR	: RATE	: 1/2
MEMORY	: =0	: =OFF	: >CRNT	: =OFF	: L=0

EVENT	:AUX BUS	:DSK ASG	:CG WIPE	: 2/2
MEMORY	: =OFF	: =OFF	: =OFF	: L=0

15-4-4. Detailed Data Selection for Loading Events

If **DIRECT** is **OFF** and while loading events, data to be loaded to the control panel can further be narrowed down in the menu as shown below.

After pressing a number button, the [EVENT RECALL] menu is displayed. The data can be reduced using the menu, in which the same parameters in the [EVENT STORE] menu can be set.

- ▶ See section 15-4-2. "Detailed Data Selection for Saving Events."
- ▶ See "Selecting Data to be Loaded" in section 15-2. "Recalling Events" for details on how to select load data.

15-5. Transitions Using Event Recall

The RATE parameter in the EVENT menu allows users to set the duration time (transition rate) for loading events. With this duration time, two images before and after recalling events that appear on program screens are automatically interpolated to create a smooth transition. The RATE setting is made while storing events. It can also be set and changed before events are recalled.

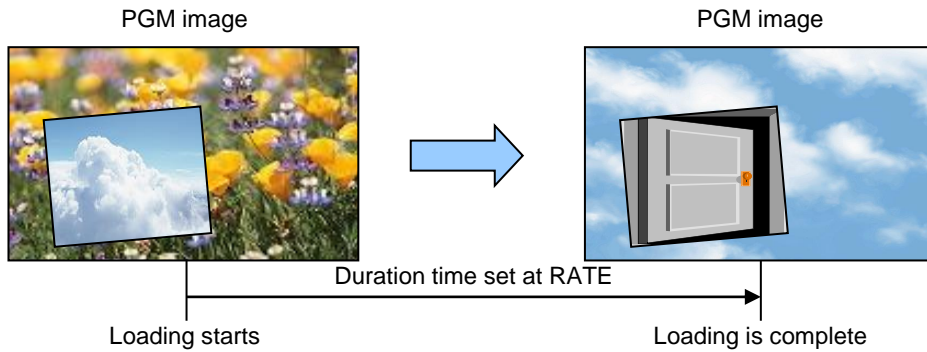

◆ Operation Example

The following operation example shows an event that is saved to EVENT No. 10 with 150 frames for RATE and it is recalled while changing RATE to 30 frames.

Saving the Event

- (1) Press **EVENT** in the SELECT/KEYPAD block to display the [EVENT MEMORY] menu.
- (2) Turn **F1** to select PAGE 1 (EVENT 10-19).

EVENT	:	PAGE	:	DIRECT	:	PAGECLR	:	RATE	:	1/2
MEMORY	:	=1	:	=OFF	:	>CRNT	:	=OFF	:	L=0

- (3) Press **STORE** to display the [EVENT STORE] menu.
- (4) Press **F4**, enter 150 in the keypad, then press **ENTER**.

EVENT	:	SELECT	:	XPT	:	DATA	:	RATE	:	1/2
STORE	:	=ALL	:	=ON	:	=ON	:	=150	:	P.01

Note that if setting RATE to 150 in the [EVENT MEMORY] menu, the initial value for RATE in the [EVENT STORE] menu will always be 150 (the default value).
--

- (5) Press **0** in the keypad to save the current panel status to EVENT 10.

Loading the Event

- (1) Press **EVENT** in the SELECT/KEYPAD block to display the [EVENT MEMORY] menu.
- (2) Turn **F1** to select PAGE 1 (EVENT 10-19).
- (3) Press **0** in the keypad to recall EVENT 10. The [EVENT RECALL] menu will be displayed.
- (4) Turn **F4** to change **RATE** from 150 to 30.

EVENT	:	SELECT	:	XPT	:	DATA	:	RATE	:	1/2
RECALL	:	=ALL	:	=ON	:	=ON	:	=30	:	P.01

- (5) Press **RECALL**. The EVENT 10 settings are loaded to the control panel, taking 30 frames.

15-6. Loading an Event at Start-up

The settings made for the background and key buses on the control panel are cleared when powering off the switcher. You can, however, recall the desired panel setup whenever the switcher starts by setting in the [SETUP - SYSTEM - INIT] menu as shown in the procedure below.

- (1) Press **MENU** in the SELECT/KEYPAD block.
- (2) Press **SETUP** to display the SETUP menu top page.
- (3) Turn **F1** to select **SYSTEM** and then press **F1**.

```

SETUP   :>SYSTEM >INPUT >OUTPUT >PANEL
MENU    :>GPI/TLY >FUNCTION>EXT I/F >STATUS
    
```

- (4) The [SETUP - SYSTEM] menu as shown below appears. Turn **F1** to select **INIT** and then press **F1** to display the [SETUP - SYSTEM - INIT] menu.

```

SETUP   :>FORMAT >REF I/O >ARCNET >ETHERNET
SYSTEM  :>RS-422 >TIME >INIT >REBOOT
    
```

- (5) Turn **F3** to select the desired panel setup in the table below

```

SYSTEM  : INIT          : LOAD :          : 1/1
INIT    : >CURRENT      : =LAST :          :
    
```

LOAD setting	Description
OFF	The switcher starts with Last Saved Settings. "Last Saved Settings" are automatically saved when the unit is rebooted or SETUP is pressed. ▶ See section 4-4. "How to Back up Settings."
LAST	The switcher starts with the last loaded event. Note that to enable the Last Load function, an event must be loaded after setting to LAST.
0-99	The switcher starts with a selected event (0-99) loaded.

16. Macros

The Macro function allows users to perform a sequence of recorded operations with the single push of a button. The keypad is used to record and execute macros. The macro memory data can be backed up and then restored from USB flash drives.

▶ See section 17 "File Operation."

16-1. Recording Macros

Up to 30 macros (3 pages with 10 macros per page) can be stored in memory.

This chapter explains how to record and save operational procedures to a macro, **Macro 12** (PAGE1, Number Button 2) as an example.

(1) Press **MACRO** in the SELECT/KEYPAD block.

The [MACRO MEMORY] menu is displayed and the keypad switches to Macro mode.

(2) Turn **F1** to select **1** (PAGE 1) in the [MACRO MEMORY] menu.

MACRO	:	PAGE	:	DIRECT	:	PAGECLR:	:	1/3
MEMORY	:	= 1	:	=OFF	:	>OFF	:	:

(3) Press **STORE** on the keypad to start recording.

(4) Perform the operational procedures that you want to record as a macro.

(5) Press **STORE** again to stop recording.

(6) Press **2** on the keypad to store the macro.

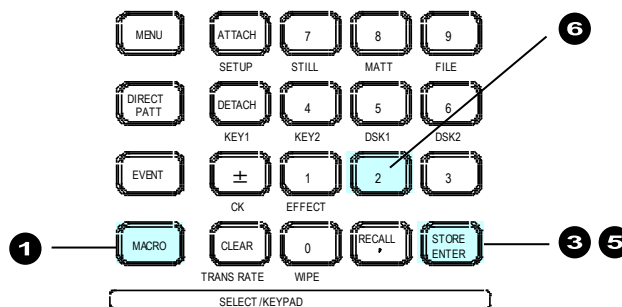

If a Macro Is Already Saved to **2** on the Keypad:

If **2** on the keypad lights green after **STORE** is pressed, a macro is already saved to the macro number (Macro 12). Press **2**. It will flash.

- To overwrite the existing data, press **2** again.
- To cancel the operation, press **STORE**.
- To save the data to another button, press a lit white number button.

If you cannot overwrite data (the button is lit red), cancel the process by pressing **STORE**, then change **OVER WR** to **ENABL** (ENABLE) in the [MACRO RECALL] menu. The menu is automatically displayed when pressing a macro-stored button.

◆ Data not saved in macro memory

- Reboot operation
- FILE menu procedures

16-2. Executing Macros

Let's execute Macro 12 (PAGE1, Number Button 2) saved in the previous page on the control panel.

- (1) Press **MACRO** in the SELECT/KEYPAD block. The [MACRO MEMORY] menu is displayed and the keypad switches to Macro mode.
- (2) Turn **F1** to select **1** (PAGE 1) in the [MACRO MEMORY] menu. Turn **F2** to set **DIRECT** to **ON** to change the mode to DIRECT RECALL.

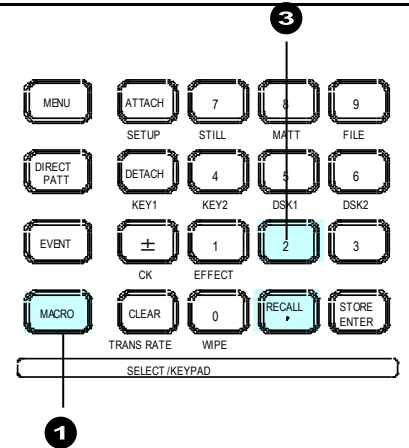

MACRO	:	PAGE	:	DIRECT	:	PAGECLR:	:	1/3
MEMORY	:	=1	:	=ON	:	>OFF	:	:

- (3) Press **2** on the keypad. Macro 12 will be executed on the control panel.

◆ If DIRECT RECALL is Disabled:

If **DIRECT** is set to **OFF** in the [MACRO MEMORY] menu, you need to press **RECALL** after pressing **2** on the keypad to execute the macro.

16-2-1. Operation Example 1

◆ Recording Actions as Macro 09

Let's perform the following actions and record them as Macro 09 (PAGE 0, Number Button 9).

- Select PGM for AUX1.
- Select PREV for AUX2.
- Press the **KEY1** transition button.

- (1) Press **MACRO** in the SELECT/KEYPAD block.
- (2) Press **STORE** on the keypad to start recording.
- (3) Press **AUX1** above the KEY/AUX bus
- (4) Press **PGM**.
- (5) Press **AUX1** above the KEY/AUX bus.
- (6) Press **PREV**.
- (7) Press **KEY1** to the right side of the fader.
- (8) Press **STORE** to stop recording.
- (9) Press **9**. The actions are saved as Macro 09.

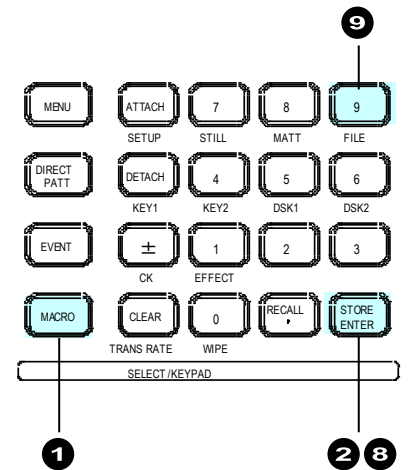

◆ Executing Macro 09

- (1) Press **MACRO** in the SELECT/KEYPAD block.
- (2) Press **9** on the keypad. (The macro is executed if DIRECT is set to ON.)
- (3) Press **RECALL** to execute Macro 09. Note that if the KEY1 image is already displayed on the program screen, it will be cleared from the screen.

16-2-2. Operation Example 2

◆ Recording Actions as Macro 10

Let's perform the following actions and record them as Macro 10 (PAGE 1, Number Button 0).

- Select Button 11 on the PST bus.
- Set the background transition type to MIX.
- Perform background transitions using the fader lever.

- (1) Press **MACRO**.
- (2) Turn **F1** to select PAGE 1 in the menu.
- (3) Press **STORE** on the keypad to start recording.
- (4) Press **11** on the PST bus.
- (5) Press **BKGD** then **MIX** in the transition block
- (6) Press the fader lever from end to end.
- (7) Press **STORE** to stop recording.
- (8) Press **0**. The actions are saved as Macro 10.

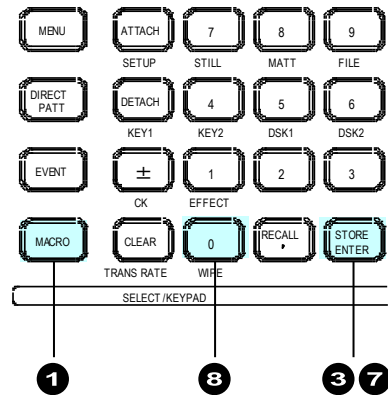

Executing Macro 10

- (1) Press **MACRO**.
- (2) Turn **F1** to select PAGE 1 in the [MACRO MEMORY] menu.
- (3) Press **0** on the keypad. (The macro is executed if DIRECT is set to ON.)
- (4) Press **RECALL** to execute Macro 10.

NOTE

Note that macros hold only values that change during recording. For fader movements, which are successively changed, macros memorize the last stopped position. Therefore, to perform the same actions as those recorded with a fader, return the fader to its previous position before a macro is executed.

16-2-3. Operation Example 3 (Using KEY/AUX Bus Buttons)

Let's execute **Macro 10** on the KEY/AUX bus.

Assume that the MACRO BUS SELECT function is assigned to **USER 3**, and **Macro 10** to **11** on the KEY/AUX bus. (Any macros can be assigned to KEY/AUX bus buttons.)

► See section 16-4-1. "Changing KEY/AUX Bus Buttons to Macro EXE Buttons."

- (1) Press **USER 3**. (The KEY/AUX bus changes to Macro mode.)
- (2) Press **11** on the KEY/AUX bus to execute Macro 10.

16-2-4. Operation Example 4 (Using Macro Attach Buttons)

Assume that **Macro 10** is assigned to **DSK1** in the transition block.

► See section 16-4-2. "Macro Attach and Macro Detach" for details.

Press **DSK1** in the transition block. The DSK1 appears in or disappears from the screen and Macro 10 is performed.

16-3. Macro Memory Operation

16-3-1. Overwrite Protection

- (1) Press **MACRO** in the SELECT/KEYPAD block to display the [MACRO MEMORY] menu.
- (2) Turn **F1** to select a memory page. Set **DIRECT** to **OFF**, if it is **ON**.

```
MACRO   : PAGE   : DIRECT : PAGECLR:       : 1/3
MEMORY  : =0     : =OFF  : >CRNT  :       :
```

- (3) Press a macro number button on the keypad. The [MACRO RECALL] menu will appear.
- (4) Turn **F1** to select **DISABLE** to set write protection on the number button.

```
MACRO   : OVER WR: DELETE : NAME = MCR01 : 1/1
RECALL  : =DSBLE: >OFF  : STEP = 60    : 
```

16-3-2. Naming Macros

Macros are named as MCR 00 to MCR 29 by default. Names for registered macros can be changed using the menu as shown below. Up to 6 characters are available.

- (1) Press **MACRO** in the SELECT/KEYPAD block to display the [MACRO MEMORY] menu and press the page down button to go to PAGE 2.
- (2) Turn **F1** to select a macro number button.

```
MACRO   : SELECT : NAME   :       : 2/3
MEMORY  : =12    : =MCR12:       :
```

Page No. Button No.

- (3) Press **F2** to move to the target character. ("R" in the example below.)
- (4) Once the character is displayed in reverse video, turn **F2** to select a new character. ("0" is selected instead of "R" in the example below.) Alphanumeric characters and symbols are available.
- (5) Press **F2** to confirm the selection.

```
: NAME   :           : NAME   :           : NAME   :
: =MCR12:           : =MCR12:           : =MC012:
      ③           ④           ⑤
```

- (6) Repeat Step (3) to (5) to change the macro name.

16-3-3. Deleting Macros

◆ To Delete Data for a Macro

- (1) Press **MACRO** in the SELECT/KEYPAD block to display the [MACRO MEMORY] menu.
- (2) Turn **F1** to select a memory page. Set **DIRECT** to **OFF**, if it is **ON**.

MACRO	:	PAGE	:	DIRECT	:	PAGECLR:	:	1/3
MEMORY	:	=0	:	=OFF	:	>CRNT	:	:

- (3) Press the number button from which data is to be deleted. The button will begin flashing when pressed.
- (3) Press a lit number button in which data is stored. The [MACRO RECALL] menu will appear.
- (4) Turn **F2** to set to **ON**, then press **F2**. The data stored in the memory button will then be cleared.

MACRO	:	OVER WR:DELETE	:	NAME = MCR01	:	1/1		
RECALL	:	=ENABLE:	:	>ON	:	STEP = 60	:	:

◆ To Delete Data for a Macro Page

- (1) Press **MACRO** to display the [MACRO MEMORY] menu.
- (2) Turn **F1** to select a memory page.
- (3) Turn **F3** to select **CRNT** under **PAGECLR**, then press **F3**. The data stored in the memory page will then be cleared.

MACRO	:	PAGE	:	DIRECT	:	PAGECLR:	:	1/3
MEMORY	:	=1	:	=OFF	:	>CRNT	:	:

◆ To Delete All Macro Data

- (1) Press **MACRO** to display the [MACRO MEMORY] menu.
- (2) Turn **F3** to select **ALL** under **PAGECLR**, then press **F3**. All macro data will then be cleared.

MACRO	:	PAGE	:	DIRECT	:	PAGECLR:	:	1/3
MEMORY	:	=0	:	=OFF	:	>ALL	:	:

16-4. Macro Execution Buttons

16-4-1. Changing KEY/AUX Bus Buttons to Macro EXE Buttons

Stored macros can be executed using the KEY/AUX bus buttons and a USER button, to which the MACRO BUS SELECT function is applied.

Once the USER button, to which MACRO BUS SELECT is assigned, is pressed to turn on. The KEY/AUX bus buttons **1** to **12** change to the **Macro EXE Buttons**. This chapter shows how to execute macros using **USER 3** and the KEY /AUX bus buttons.

1. Assigning MACRO BUS SELECT to USER 3

(1) Open the [SETUP - PANEL - USER BTN] (1/2) menu.

(2) Turn **F1** to select OU-3 (USER 3). **USER 3** will blink.

(3) Turn **F2** to select OTHER, then turn **F3** to select MACRO BUS SELECT.

▶ See section 14. "USER Buttons." for details.

USER	: SELECT	: TYPE	: FUNC(F3)	: 1/2
BUTTON	: =OU-3	: =OTHER	: =MACRO BUS SELECT	

2. To Assign Macros to the KEY/AUX Bus Buttons

Any macros can also be assigned to the KEY/AUX bus buttons as shown below.

(1) Press **MACRO** in the SELECT/KEYPAD block.

(2) The [MACRO MEMORY] menu will appear. Go to PAGE 3.

(3) Turn **F1** to select a KEU/AUX bus button. Turn **F3** to select a macro to be assigned.
(Macro 00 is assigned to KEY/AUX button 1 in this example.)

MACRO	: BUTTON	: MACRO/NAME	: 3/3
BUS ASGN:	=01	=00 =MCR00	:

3. Executing Macro 00

(1) Press **USER 3**. (The KEY/AUX bus changes to Macro mode.)

(2) To execute Macro 00, press Bus Button **1**.

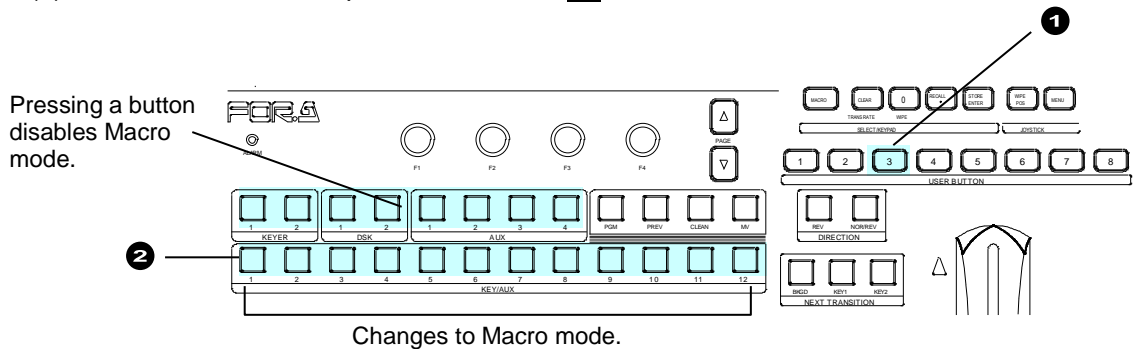

To disable Macro mode in the KEY/AUX bus, press a bus selection button (KEY1-2, DSK1-2, or AUX1 to 4.)

Note that the KEY/AUX bus cannot be used for signal selections in Macro mode.

16-4-2. Macro Attach and Macro Detach

Any button on the control panel can be used as a macro execution button. To do so, assign a macro to a button (Macro Attach). Once a macro is attached to a button, the macro is executed whenever the button is pressed. Macro Detach allows you to remove macros from buttons.

This chapter shows how to attach Macro 10 to transition button **DSK1** as an example.

◆ To Assign Macro 10 to **DSK1** in the transition block.

- (1) Press **MACRO**.
- (2) Turn **F1** to select **PAGE 1** in the [MACRO MEMORY] menu.
Set **DIRECT** to **OFF**, if it is set to **ON**.
- (3) Press **0** on the keypad to select Macro 10.
- (4) Press **ATTACH** on the keypad.
- (5) Press **DSK1** in the transition block.
- (6) Press **ATTACH** on the keypad again.

Press **DSK1**.
DSK1 is set to **ON** (or **OFF**) and Macro 10 is executed.

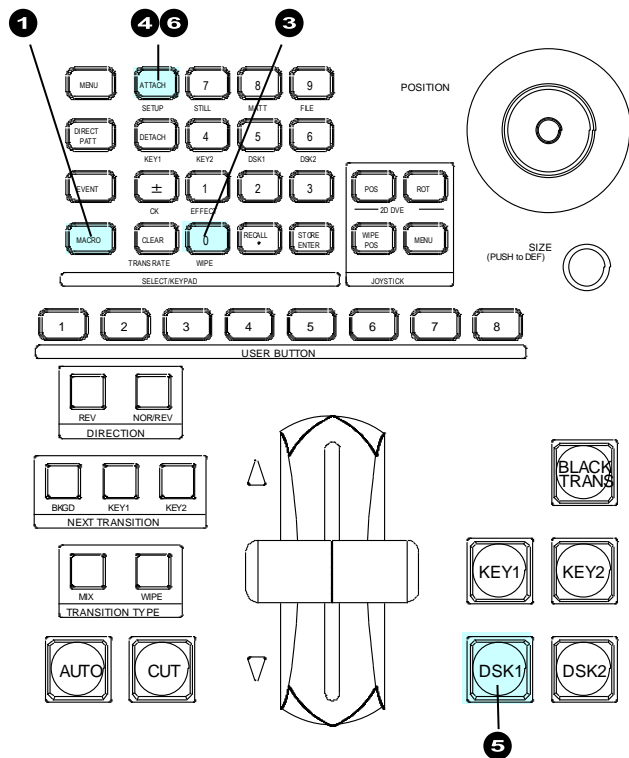

◆ To Remove the Macro from **DSK1**

- (1) Press **MACRO**.
- (2) Press **DETACH** on the keypad.
- (3) Press **DSK1** in the transition block.
(You can also press other buttons to be detached here.)
- (4) Press **DETACH** on the keypad again.

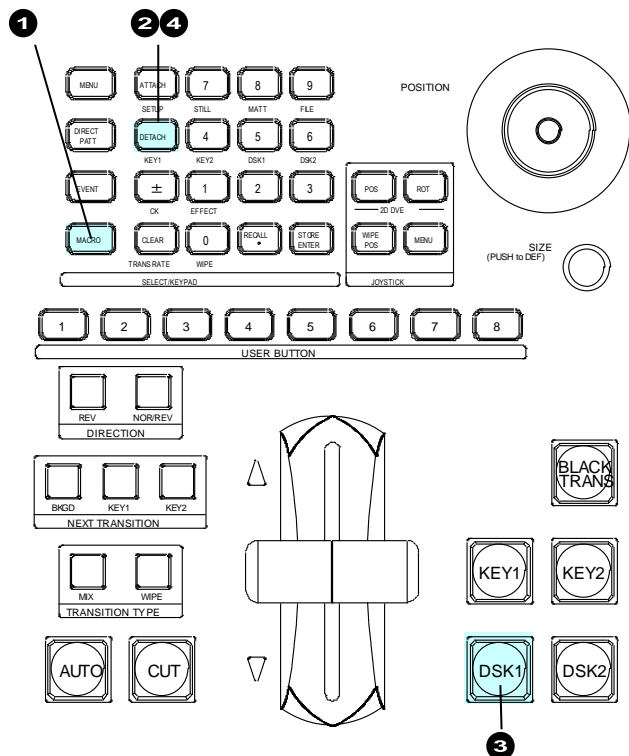

17. File Operation

The switcher is capable of storing operational data to USB flash drive and of recalling and downloading previously saved data for application to production operations. Operational data including system settings, wipe settings, stills, bus settings and events can be all saved to and downloaded from the USB flash drive.

17-1. USB Flash Drive

- See "Factory Tested USB Flash Drives" in Appendix 1 for available USB flash drives. Insertion and removal of USB drives should be performed slowly and firmly.
- The access lamp on the USB flash drive blinks while saving or reading data. Check access to the USB flash drive before and while performing an operation. **Do not** remove a USB flash drive while the access lamp is flashing. Doing so could corrupt the stored data or damage the USB flash drive.
- The remaining storage space on the USB memory device is displayed at the bottom right-hand side in the FILE menu.

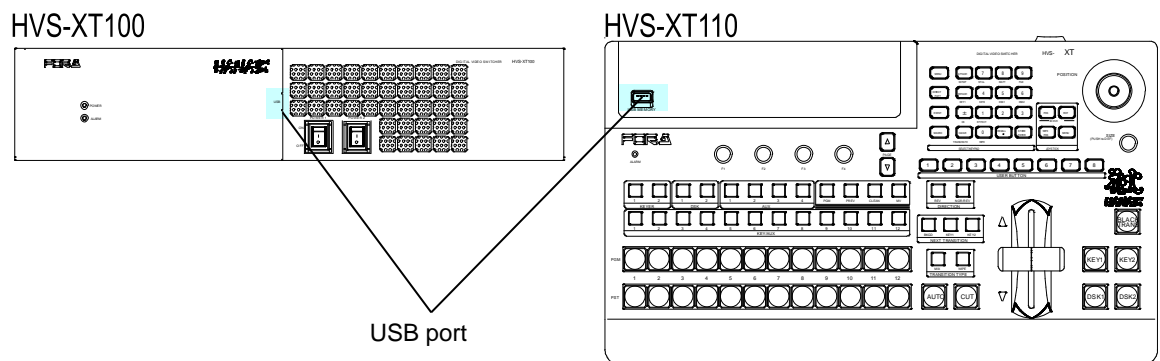

17-2. Supported Files

See "Appendix 1. Supported File Types" for details on the supported imagefiles.

IMPORTANT

To use USB flash drives with the switcher, format them in a FAT or FAT32 file system.

17-3. Saving Data to USB Flash Drives

This section explains how to save panel settings to USB memory using a "data.all" file as an example.

- (1) Insert a USB flash drive into the USB port.
- (2) Press **MENU** in the SELECT/KEYPAD block, then press **FILE** to open the FILE top menu.
- (3) Turn **F1** to select **SAVE**, and then press **F1** or the page down button to open the [FILE - SAVE] menu.

FILE	:	>LOAD	> SAVE	>UPDATE
TOP	:			

- (4) Turn **F1** to select **ALL** to the **EXT** (File Extension) item.
- (5) Turn **F3** to select **DATA.ALL**.
 - ▶ See section 17-5 "Moving between USB Flash Drive Directories."
Press **F3** to save the data to the USB memory.

FILE	:	EXT	:	CTRL	:	DATA.ALL	:	1/1
SAVE	:	= ALL	:	=SAVE	:		:	101MB

- (6) When the data is sent to the flash memory, the message "SAVE?" will appear. Press **F3** again to store the data to the flash memory. A "beep" sound will be heard when the data is saved.

◆ If the same file exists in the USB flash drive:

A pop up window appears and asks if you would like to overwrite the existing file. Turn **F3** to select **CANCEL**, **OVERWR**(overwrite) or **RENAME**.

◆ To Rename the File:

If you wish to rename the file to save it, turn **F3** to select **RENAME** and give a new name to the file

- ▶ See section 17-7. "Renaming Files in USB Flash Drives."

IMPORTANT
When pressing a control push-button, press down lightly and release it within 1 sec. Note that if you press and hold a control button down for more than 1 sec., the associated operation will be cancelled.
Do not remove the USB flash drive while the access lamp is flashing. Doing so could corrupt the stored data or damage the USB flash drive.
The time is also recorded when data is saved to a USB flash drive according to the internal switcher clock. Set the date, time and time zone if it is not properly set.
▶ See section 3-5. "Setting Date, Time and Time Zone."

17-4. Loading Data from USB Flash Drives

17-4-1. Loading Setting Data

This section explains how to load setting data to the USB memory by using a "data.all" file as an example.

- (1) Insert a USB flash drive into the USB port.
- (2) Press **MENU** in the SELECT/KEYPAD block, then press **FILE** to open the FILE top menu.
- (3) Turn **F1** to select **LOAD**, and then press **F1** or the page down button to open the [FILE - LOAD] menu.

FILE	:	LOAD	>SAVE	>UPDATE
TOP	:			

- (4) Turn **F1** to select **ALL** to the **EXT** (File Extension) item.
- (5) Turn **F3** to select data.
 - ▶ See section 17-5 "Moving between Directories in the USB Flash Drive."

FILE	:	EXT	:	LOAD	:	<DIR>..	:	1/2
LOAD	:	=ALL	:		:		:	DATA: 101MB

- (6) Press **F3** (or **F2**) to load the setting data to the control panel.

IMPORTANT	
Once the saved system data (files with "all" or "sys" extension) finishes loading, you will have to restart the switcher. (The unit should be powered off then powered ON.) The system data is applied only after the switcher is restarted.	
Be careful when loading system data (setting files with "all" or "sys" file extension), because the switcher cannot connect and communicate with peripheral devices if different connection settings are loaded.	

17-4-2. Downloading Image Files

When loading a jpeg, targa or bitmap file from the USB flash drive, a centered, tiled or normal file format can be selected. This section explains how to download the "sample.jpg" file to STILL1 as an example.

- (1) Insert a USB flash drive into the USB port.
- (2) Press **MENU** in the SELECT/KEYPAD block, then press **FILE** to open the FILE top menu.
- (3) Turn **F1** to select **LOAD**, and then press **F1** to open the [FILE - LOAD] menu.
- (4) Turn **F1** to select **JPG** under **EXT** (File Extension).
- (5) Turn **F2** to select **STL1** under **LOAD** as an upload destination.
- (6) Turn **F3** to select sample.
 - ▶ See section 17-5 "Moving between Directories in the USB Flash Drive."

FILE	:	EXT	:	LOAD	:	<DIR>..	:	1/2
LOAD	:	=JPG	:	=STILL1	:		:	sample : 101MB

- (7) Press **F3** (or **F2**) to load the image file to STILL1 memory.

- ◆ **Image files can be uploaded to the following memory buffers in the switcher:**

Upload destination	LOAD setting using F2	Description
Still memory	STILL1 STILL2	Uploads an image file to a still memory buffer.
	STILL1C STILL2C	Uploads an image file to a still memory buffer in a centered format.
	STILL1T STILL2T	Uploads an image file to a still memory buffer in a tiled format.
Backup memory	FMEM1 to FMEM4	Uploads image files to a still backup memory buffer.
Input Stills	IN01 to IN14	Uploads an image file to an input frame memory (a frame buffer ordinarily used by the Frame Synchronizer) Once an image is stored to an input buffer, instead of input video, the uploaded still image will continue to be displayed from this input. To display the input video again on the input bus, perform CLEAR in the [INPUT STILL] menu. ▶ See section 5-4. "INPUT STILL (Freezing Input Video)."

17-5. Moving between USB Flash Drive Directories

USB flash drive directories are displayed after "<DIR>", e.g. <DIR>JPEG, toward the upper right of the FILE menu as shown below.

FILE	:	EXT	:	LOAD	:	<DIR>JPEG	:	1/2
LOAD	:	=JPG	:	=STIL1:	:	sample:	:	101MB

Directory name

File name

In all FILE menus you can move to other directories in a USB flash drive in the following way.

- (1) In the [FILE - SAVE] menu, turn **[F2]** to select **PATH** in the FILE menu, and then press **[F2]**. The menu display changes to the directory menu.
- (2) If you want to go to a subdirectory of the current directory, turn **[F3]** to select the directory name and press **[F3]**. If you want to go to a higher directory, select **<DIR>...**

NOTE

New directories cannot be prepared in the switcher. If necessary, prepare a new directory in the computer beforehand.

17-6. Deleting Files from USB Flash Drives

The user can delete files from USB flash drives using the FILE menu operation.

- (1) Open the [FILE - LOAD] menu. If you are in the [FILE - SAVE] menu, press the page up button to go to the FILE top menu and move to the [FILE - LOAD] menu.
- (2) Press the page down button to go to the [FILE - LOAD - DATA] menu.
- (3) Turn **F1** to select the extension of the file you wish to delete from the flash memory.
- (4) Turn **F3** to select the file to be deleted.
- (5) Turn **F2** to select **DELETE** under the **CTRL** item and press **F2**.
- (6) Turn **F3** to select **ON**, then press **F3**. A "beep" sound will be heard when the data has been deleted.

FILE	:	EXT	:	CTRL	:	<DIR>JPEG	:	2/2
DATA	:	=JPG	:	=DELET:	:	STILL1:	:	101MB

17-7. Renaming Files in USB Flash Drives

The user can input an identifying name of up to 16 alphanumeric characters for any file stored to USB flash drive. Existing files can also be named / renamed using the following procedure.

- (1) Open the [FILE - LOAD] menu. If you are in the [FILE - SAVE] menu, press the page up button to go to the FILE top menu and move to the [FILE - LOAD] menu.
- (2) Press the page down button to go to the [FILE - LOAD - DATA] menu.
- (3) Turn **F1** to select the extension of the file you wish to rename in the displayed file list.
- (4) Turn **F2** to select **RENAME**.
- (5) Turn **F3** to select which file you wish to rename in the displayed file list.
- (6) Press **F2** to start renaming
- (7) Press **F3** to select the character to be changed in the selected file. Turn **F4** to change the currently chosen character.

FILE	:	EXT	:	CTRL	:	STILL1 :	:	2/2
DATA	:	=JPG	:	=RENAM:	:	SELECT:	:	CHARA: 101MB

- (8) Repeat step (7) to change each character in the name of the selected file.
- (9) When all needed characters are input, press **F2**. A "beep" sound will be heard when the changed name has been saved as the new file name.

18. System Setup Settings

18-1. Selecting System Signal Format

- (1) Press **MENU** in the SELECT/KEYPAD block, then press **SETUP** to display the SETUP top menu.
- (2) Turn **F1** to select **SYSTEM**, then press **F1** or the page down button to open the [SETUP - SYSTEM] menu.
- (3) Turn **F1** to select **FORMAT**, then press **F1** or the page down button to open the [SETUP - SYSTEM - FORMAT] menu.

```

SETUP   :>FORMAT >REF I/O >ARCNET >ETHERNET
SYSTEM  :>RS-422 >TIME   >INIT   >REBOOT
    
```

- (4) Turn **F1** to select the TV format, then press **F1**.
Turn **F3** to select the aspect ratio, then press **F3**.

```

SYSTEM  : FORMAT           :ASPECT :SW TMNG: 1/1
FORMAT  : =1080/59.94i    : =16:9 : =ANY   :
    
```

- (5) Press the page up button to go back to the [SETUP - SYSTEM] menu.
- (6) Turn **F1** to select **REBOOT** and then press **F1**. Press the **ENTER** button in the SELECT/KEYPAD block to reboot the system.

```

SETUP   :>FORMAT >REF I/O >ARCNET >ETHERNET
SYSTEM  :>RS-422 >TIME   >INIT   >REBOOT
    
```

- (7) The selected system format is applied to the switcher after rebooting.

18-2. Crosspoint Switch Timing

The switcher can be set when and where crosspoints are switched.

- (1) Open the [SETUP - SYSTEM - FORMAT] menu. (See the procedure above.)
- (2) Turn **F4** to set the switcher timing at the **SW TMNG** item.

```

SYSTEM  : FORMAT           :ASPECT :SW TMNG: 1/1
FORMAT  : =1080/59.94i    : =16:9 : =ANY  :
    
```

Signal Format	Setting	Description
1080i/59.94, 50 525/60 625/50	ODD	Switches crosspoints in odd fields.
	EVEN	Switches crosspoints in even fields.
	ANY	Switches crosspoints any time commands are issued.
720p/59.94, 50	No1	Switches crosspoints in odd frames.
	No2	Switches crosspoints in even frames.
	ANY	Switches crosspoints any time commands are issued.
1080PsF/29.97, 25, 24, 23.98	---	Switches crosspoints at the same time regardless of setting.

18-3. Selecting a Reference Signal

The switcher provides a reference input, its loop-through and output connectors in the GENLOCK section on the rear panel.

18-3-1. To Set Reference Input

- (1) Press **MENU** in the SELECT/KEYPAD block, then press **SETUP** to display the SETUP top menu. Turn **F1** to select **SYSTEM**, then press **F1** or the page down button to open the [SETUP - SYSTEM] menu.
- (2) Turn **F1** to select **REF I/O**, then press **F1** or the page down button to open the [SETUP - SYSTEM - REF IN] menu.
- (3) Turn **F1** to select a reference signal to be input to the switcher between Black Burst and Tri-level Sync.
- (4) Adjust the horizontal phase under **H PHS**.

SYSTEM	:	TYPE	:	H PHS	:		:	1/2
REF IN	:	=B_B	:	=0	:		:	

18-3-2. To Set Reference Output

- (1) Press the page down button in the [SETUP - SYSTEM-REF IN] menu to go to the [SETUP - SYSTEM - REF OUT] menu.
- (2) Turn **F1** to select a reference signal to be output from the switcher between Black Burst and Tri-level Sync.
- (3) You can adjust the horizontal phase of the reference signal under **H PHS** and the vertical phase under **V PHS**.

SYSTEM	:	TYPE	:	H PHS	:	V PHS	:	2/2
REF OUT	:	=B_B	:	=0	:	=0	:	

18-4. Setting Date, Time and Time Zone

- (1) Open the [SETUP - SYSTEM] menu.
- (2) Turn **F1** to select **TIME**, then press **F1** or the page down button to open the [SETUP - SYSTEM - TIME] menu.

SETUP	:	>FORMAT	>REF I/O	>ARCNET	>ETHERNET
SYSTEM	:	>RS-422	> TIME	>INIT	>REBOOT

- (3) If you need to change the date, press **F1** to select Month, Day or Year, then turn **F1** to change the setting.
- (4) If you need to change the time, press **F3** to select Hour, Minute or Second, then turn **F3** to change the setting.

SYSTEM	:	DATE(mm/dd/yy)	:	TIME [10:20:10]	:	1/4
TIME	:	=JUL/14/10	:	=10:20:20	:	

- (5) To set the time zone, open [SETUP - SYSTEM - TIME] menu PAGE 2.
- (6) Turn **F3** to set the time zone offset value.

SYSTEM	:	1st CHK:SUMMER	:	TIME ZONE	:	2/4
TIME	:	=OFF	:	=OFF	:	=UTC[9:00]

IMPORTANT

The date and time information are used for the multiviewer clock and when backing up image or setting files. Note that date and time information may be lost if the switcher is powered OFF for more than 100 hours (or less if it is not fully charged). In such case, reset the date and time.

18-4-1. Setting Time Using SNTP (Time) Server

The switcher time can be synchronized to a time (SNTP) server using the Simple Network Time Protocol (SNTP).

To synchronize the time to a SNTP server time, enter the IP address of your SNTP server, set the time zone, then update the time manually. After time settings are completed, it is recommended to turn on automatic updates (at start-up and/or fixed time).

SNTP server time may not be correct due to a network delay or other reasons. To improve time precision, locate an SNTP server in your local network zone.

◆ Setting the IP address of SNTP Server

(1) Open [SETUP - SYSTEM - TIME] menu PAGE 3.

(2) Press **F1** to highlight the first octet (192 in the menu example below) of the IP address.

```
SYSTEM :SNTP SERVER IP ADDRESS :UPDATE : 3/4
TIME   : =192.168.000.011       : >EXEC :
```

(3) Turn **F1** to change the value and press **F1**.

(4) Repeat Steps (2) and (3) to set the server IP address.

◆ Time Zone Setting

The SNTP server provides the UTC (Coordinated Universal Time). To display the correct local time, set your time zone.(See the previous page.)

◆ Manual Time Update

(1) Open [SETUP - SYSTEM - TIME] menu PAGE 3.

(2) Press **F4**. A short-beep sound will be heard and the switcher time will be updated.

```
SYSTEM :SNTP SERVER IP ADDRESS :UPDATE : 3/4
TIME   : =192.168.000.011       : >EXEC :
```

◆ Automatic Time Update

To update time at switcher start-up:

Set 1st **CHK** to **ON** in [SETUP - SYSTEM - TIME] menu PAGE 2.

```
SYSTEM :1st CHK:SUMMER :TIME ZONE      : 2/4
TIME   : =ON          : =OFF          : =UTC[ 9:00] :
```

To update time at fixed intervals:

Set the update time under **UPDATE TIME** in [SETUP - SYSTEM - TIME] menu PAGE 4.

The **INTRVL** (INTERVAL) parameter allows you to set OFF, 1HOUR, 3HOUR, 6HOUR, 12HOUR and 1DAY, and to update the time at the set interval starting from the time set in the **UPDATE TIME**.

```
SYSTEM :UPDATE TIME      :INTRVL :          : 4/4
TIME   : =12:00         : =3HOUR :          :
```

◆ **Summer Time Setting**

If **SUMMER** is set to **ON** in [SETUP - SYSTEM - TIME] menu PAGE 4, the time will be set one-hour advanced relative to the standard (non-summer) time.

```
SYSTEM :1st CHK:SUMMER :TIME ZONE : 2/4
TIME : =ON : =ON : =UTC[ 9:00] :
```

18-5. Buzzer, Brightness and Screen Saver

The brightness of the display and control panel buttons can be adjusted in the menu. You can also set the buzzer On/Off and the start time of the screen saver shown on the menu display.

(1) Open the [SETUP - PANEL] menu.

```
SETUP :>UTILITY >TRS CTRL >USER BTN
PANEL :
```

(2) Turn **F1** to select **UTILITY**, then press **F1** or the page down button to open the [SETUP-PANEL-UTILITY] menu.

```
PANEL :BUZZER :S-SAVER:BRIGHT : : 1/1
UTILITY : =OFF : =5 : =6 : :
```

Parameter	Description
BUZZER	Sets the buzzer On or Off.
S-SAVER	Sets the start time of the screen saver in minutes. Set to OFF if you do not want to use the screen saver.
BRIGHT	Sets brightness for the display and buttons.

18-6. Status Information

The STATUS menu indicates current cooling fan, power and genlock status and the versions of hardware and software.

18-6-1. Checking Alarm Status

- (1) Open the [SETUP - STATUS] menu. Turn **F1** to select **ALARM**, then press **F1** or the page down button to display the submenu.

```

SETUP   :>ALARM   >VERSION >OPTION
STATUS  :
    
```

- (2) The STATUS submenus display the current status of the cooling fan, power and genlock as shown below.

◆ HVS-XT100

```

STATUS  : FAN1: NOR  2: NOR           : 1/3
MU ALARM: PS1: NOR  2: NOR           :
    
```

```

STATUS  : GENLOCK:External Lock      : 2/3
MU ALARM:                             :
    
```

```

STATUS  : PS1: NOR  2: NOR           : 3/3
OU ALARM:                             :
    
```

Item	Display	Description
FAN1-2 (MU)	NOR	Indicates FANs are working properly.
	ERR	Indicates a FAN has failed. Power off the switcher and consult your FOR-A reseller.
GENLOCK	External Lock	Indicates a valid reference signal is present and video signals are properly locked to the reference signal.
	Internal Lock	Indicates the internal reference is being used, and as such, either the absence of external reference signal, its level is too low, or the presence of a reference in a different format.
PS1-2 (MU, OU)	NOR	Indicates Power Supply Units are working properly.
	---	Indicates no power supply. (OU only)
	ERR	Indicates a Power Supply Unit has failed. Power off the switcher and consult your FOR-A reseller. (MU only)

◆ HVS-XT110

```

STATUS  : FAN1: NOR FAN2: NOR FAN3: NOR : 1/2
MU ALARM:                             :
    
```

```

STATUS  : GENLOCK:External Lock      : 2/2
MU ALARM:                             :
    
```

Item	Display	Description
FAN1-3	NOR	(see the table above.)
	ERR	
GENLOCK	External Lock	
	Internal Lock	

18-6-2. Verifying Versions

To verify the version of software and FPGA firmware installed in the switcher, open the [SETUP - STATUS - VERSION] menu. Before upgrading the switcher, be sure to check the relevant version in this menu.

```
STATUS :SOFT MAIN:v1.00.0 GUI:v1.00.0 : 1/3
VERSION :      OU :v1.00.0  RU :v1.00.0 :
```

```
STATUS :FPGA GL :v01-00 SDI :v01-00 : 2/3
VERSION :(MU) ME :v01-00 :
```

```
STATUS :FPGA DEV1:v01-00 DEV2:v01-00 : 3/3
VERSION :(OU) DEV3:v01-00 :
```

Item	Description	
SOFT MU MAIN	HVS-XT100/110	Software version
SOFT MU GUI	HVS-XT100/110	Software version
SOFT OU	HVS-XT100/110	Software version
SOFT RU	HVS-30RU	Software version
FPGA (MU) GL	HVS-XT100/110	FPGA firmware version for Genlock
FPGA (MU) ME	HVS-XT100/110	FPGA firmware version for ME
FPGA (MU) SDI	HVS-XT100/110	FPGA firmware version for SDI
FPGA (OU) DEV1-3	HVS-XT100/110	CPLD1-3 firmware version

18-6-3. Installed Options

To verify installed options in the switcher, open the [SETUP - STATUS - OPTION] menu. The menu shows hardware and software options installed to the switcher as shown below.

◆ HVS-XT100

```
STATUS :SLOT-A >(not install) : 1/7
OPTION :SLOT-B >(not install) :
```

```
STATUS :SLOT-C >(not install) : 2/7
OPTION :HVS-XT100ARC>INSTALLED :
```

```
STATUS :HVS-XT100ED >(not install) : 3/7
OPTION :HVS-XT100VR >(not install) :
```

```
STATUS :HVS-XT100EXP3G >(not install) : 4/7
OPTION : :
```

```
STATUS :UNIT1 SOFT:v-.-.-.- CPLD:v----- : 5/7
AUX UNIT:UNIT2 SOFT:v-.-.-.- CPLD:v----- :
```

```
STATUS :UNIT3 SOFT:v-.-.-.- CPLD:v----- : 6/7
AUX UNIT:UNIT4 SOFT:v-.-.-.- CPLD:v----- :
```

STATUS :UNIT5 SOFT:v-.-.-.- CPLD:v-----	: 7/7
AUX UNIT:	:

◆ **HVS-XT110**

STATUS :HVS-XT100ARC>INSTALLED	: 1/5
OPTION :HVS-XT100ED >(not install)	:

STATUS :HVS-XT100VR >(not install)	: 2/5
OPTION :HVS-XT100EXP3G >(not install)	:

STATUS :UNIT1 SOFT:v-.-.-.- CPLD:v-----	: 3/5
AUX UNIT:UNIT2 SOFT:v-.-.-.- CPLD:v-----	:

STATUS :UNIT3 SOFT:v-.-.-.- CPLD:v-----	: 4/5
AUX UNIT:UNIT4 SOFT:v-.-.-.- CPLD:v-----	:

STATUS :UNIT5 SOFT:v-.-.-.- CPLD:v-----	: 5/6
AUX UNIT:	:

18-7. Upgrading an Operational Version

Consult your FOR-A supplier in order to upgrade your switcher.
Before upgrading, check the current version of the software and firmware in the [SETUP - STATUS - VERSION] menu.

You will need to use the FILE special menu function to download and apply operational software files in a USB flash drive. The files listed below contain the software upgrades for your switcher.

◆ Upgrade Files

File extension	Description
MDB	For software updates
MDH	For software updates
MFB	For FPGA firmware updates
MVF	For MV firmware updates

◆ Upgrade Files for HVS-30RU

File extension	Description
RUB	For HVS-30RU software updates

◆ Option Setting Files for HVS-XT100/110

File extension	Description
SOP	For installing HVS-XT100/110 options

18-7-1. Upgrade Procedure

Once the system is upgraded, all setting data will be lost and return to their factory default settings. Important setting data should be backed up by saving it to USB flash drive.

To upgrade your switcher, follow the procedure below:

Step	Description	Refer to
1	Save current setting data (All data) to USB flash drive.	17-3
2	Upgrade the software	18-7-2
3	Reboot the switcher.	19-1
4	Initialize the switcher.	19-2
5	Load the setting data saved at step 1.	18-7-3
6	Reboot the switcher.	19-1

IMPORTANT

Once the saved system data is loaded, you will have to restart the switcher. (Power the unit OFF then ON.) Network settings are applied only after the switcher is restarted.

18-7-2. Upgrading the Switcher

- (1) Insert the USB flash drive that contains the upgrade data into the USB port.
- (2) Press **MENU** in the SELECT/KEYPAD block, then press **FILE** to open the FILE top menu.
- (3) Turn **F1** to select **UPDATE**, then press **F1** or the page down button to open the [FILE - UPDATE] menu.

FILE	:	>LOAD	>SAVE	> UPDATE
TOP	:			

FILE	:	EXT	:	LOAD	:	<DIR>		1/1
UPDATE	:	= MDB	:		:		XXXXXXXX	101MB

- (4) Turn **F1** to select **MDB** under **EXT** (File Extension).
- (5) Turn **F3** to select an MDB file.
- (6) Press **F3** to start upgrading.

IMPORTANT
DO NOT turn the power of your units OFF or try to remove the USB flash drive from the port until the file downloads are complete!

- (7) In the [FILE-UPDATE] menu screen, the pop-up status window appears showing the file transfer progress.
- (8) About 1 minute later, when the download has successfully completed, "COMPLETE" will appear on the display.
- (9) Restart the switcher to complete the upgrade.

IMPORTANT
Upgrade your switcher system with other upgrade files in the same manner as that of the above procedure. To complete upgrade procedures, restart the switcher system manually. Installation times are approximately 1-4 minutes for MDB, MDH, MFB and RUB files respectively

18-7-3. Loading Setting Data

All previously set switcher menu settings can be reset by loading the "DATA.ALL" file from the USB Disk.

- (1) Insert the USB flash drive with saved data into the USB port.
- (2) Press **FILE** to display the top page of the FILE menu.
- (3) Turn **F1** to select **LOAD**, then press **F1** to display the [FILE - LOAD] menu.
- (4) Turn **F1** to select **ALL** under **EXT** (File Extension).
- (5) Turn **F3** to select **data**. (The file name of the data must be "DATA.ALL", if it is not renamed.)
- (6) Press **F3** (or **F2**) to start loading the file.
- (7) The data transfer will take approx. 30 seconds to complete.
- (8) After loading the data, reboot the switcher.

19. Reboot and Initialize

19-1. Rebooting System

- (1) Press **MENU** in the SELECT/KEYPAD block, then press **SETUP** to display the SETUP top menu.
- (2) Turn **F1** to select **SYSTEM**, then press **F1** or the page down button to open the [SETUP - SYSTEM] menu.
- (3) Turn **F1** to select **REBOOT**, then press **F1**. Press the **ENTER** button in the SELECT/KEYPAD block to reboot the system.

SETUP	:	>FORMAT	>REF I/O	>ARCNET	>ETHERNET
SYSTEM	:	>RS-422	>TIME	>INIT	> REBOOT

19-2. System Initialization

To initialize the system settings, follow the procedure below.

- (1) Press **MENU** in the SELECT/KEYPAD block, then press **SETUP** to display the SETUP top menu.
- (2) Turn **F1** to select **SYSTEM**, then press **F1** or the page down button to open the [SETUP - SYSTEM] menu.
- (3) Turn **F1** to select **INIT**, then press **F1** or the page down button to display the [SETUP - SYSTEM - INIT] menu.

SETUP	:	>FORMAT	>REF I/O	>ARCNET	>ETHERNET
SYSTEM	:	>RS-422	>TIME	> INIT	>REBOOT

- (4) Turn **F1** to select **SETUP(expSYS)**, then press **F1** to initialize the switcher setup data aside from the system data.

SYSTEM	:	INIT	:	LOAD	:	:	1/1
INIT	:	> CURRENT	:	=LAST	:	:	:

CURRENT: Resets settings for the BKGD, KEY, DSK, MATT, CHR KEY, SUB EFFECT, TRANS and WIPE menus.

SETUP(expSYS): Resets the SETUP menu parameters and still memory, aside from the following parameters:

- FORMAT in the [SETUP - SYSTEM - FORMAT] menu
- All parameters in the [SETUP - SYSTEM - ARCNET] menu
- All parameters in the [SETUP - SYSTEM - ETHERNET] menu
- All parameters in the [SETUP - SYSTEM - TIME] menu

CUR&SETUP: Resets settings including CURRENT and SETUP(expSYS) above.

FACTORY: Resets DIRECT PATT, EVENT and MACRO data and all parameter settings in CURRENT and SETUP (all SETUP menu parameters) parameters above.

- ▶ See section 4-3. "How to Return Settings to Default" for details on initializing menus.
- ▶ See section 15-6. "Loading Event at Start-up" for details on loading desired settings at system startup.

20. External Device Connection

20-1. GPI IN/OUT and Tally Outputs

The switcher can control external devices or can be controlled by external devices via the GPI interface.

20-1-1. GPI IN/TALLY OUT Connector

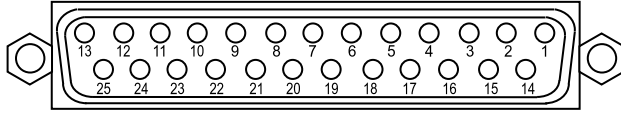

◆ **Pin Assignment Table (25-pin D-sub, female, with inch screws)**

Pin No.	Description
1	BKGD AUTO TRANS (input) (default setting)
2	KEY1 AUTO TRANS (input) (default setting)
3	KEY2 AUTO TRANS (input) (default setting)
4	DSK1 AUTO TRANS (input) (default setting)
5	DSK2 AUTO TRANS (input) (default setting)
6-24	No assignment (default setting)
25	Frame ground

◆ **GPI IN Circuit**

Open Collector or no-voltage contact input

Switch or Relay

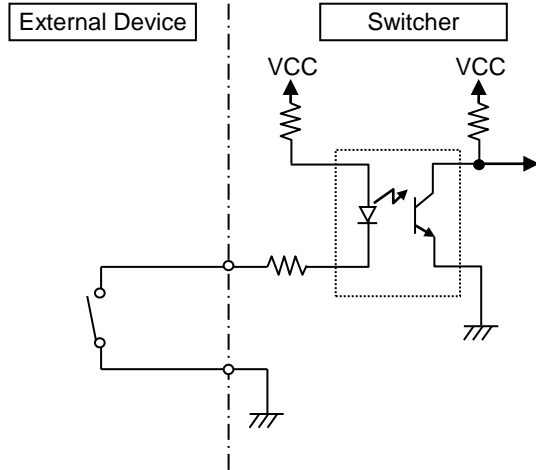

Open Collector

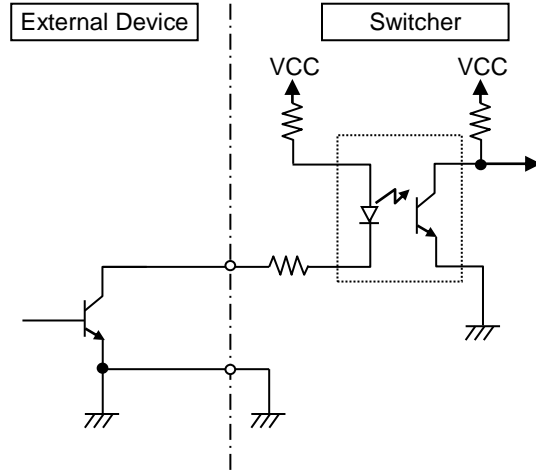

◆ **GPI OUT/ TALLY OUT Circuit**

Open-collector output (Max. load voltage: 40 VDC, max. load current: 100 mA)

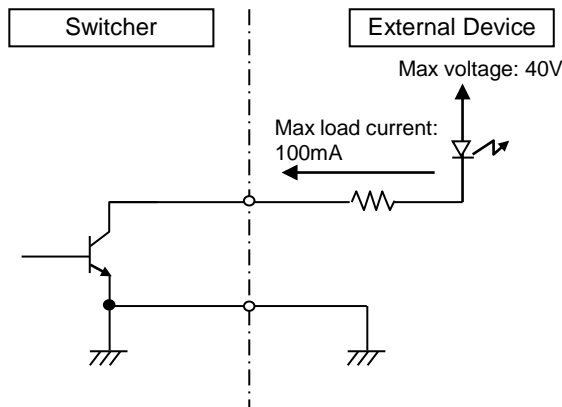

Shielded cables are recommended when fabricating your own cables.

20-1-2. Pin Assignment Examples

The GPI input and output and tally output functions are freely assignable to each pin of the GPI IN/TALLY OUT connector. This chapter explains how to assign these functions using five examples described in the table below.

Example	Pin	I/O	Function	Signal type	
1	GPI In	2	In	Performs the BKGD AUTO transitions.	Negative edge
2	GPI In	2	In	Performs the DSK1 AUTO (MIX) transitions.	Negative edge
3	GPI Out	9	Out	Outputs the GPI signal while background transitions are being performed.	Active low
4	Tally	17	Out	Outputs RED tallies while IN01 is selected on the PGM bus.	Active low
5	Tally	18	Out	Outputs GREEN tallies while IN01 is selected on the PST bus.	Active low

Two or more functions can be assigned to a GPI input pin. In examples **1 and 2** in the table above, when **Pin 2** is activated by a GPI input pulse, the BKGD and DSK1 AUTO transitions are simultaneously performed. Up to 60 pairs of pin and function can be set.

► See section 20-1-4 "GPI/Tally Function List."

◆ GPI Inputs

Ex. 1: Performs background AUTO transitions using PIN 2.

Ex. 2: Performs DSK1 AUTO (MIX) transitions using PIN 2.

To set the above GPI IN examples, proceed as follows.

Displaying the [SETUP-GPI/TLY] Menu

- Press **[MENU]** in the SELECT/KEYPAD block, then press **[SETUP]** to display the SETUP top menu.
- Turn **[F1]** to select **GPI/TLY**, then press **[F1]** or the page down button to open the [SETUP - GPI/TLY] menu.

```

SETUP   :>SYSTEM >INPUT >OUTPUT >PANEL
MENU    :>GPI/TLY >FUNCTION>EXT I/F >STATUS
    
```

- Turn **[F1]** to select **GPI I/O** in the [SETUP - GPI/TLY] menu, then press **[F1]** or the page down button to open the [SETUP - GPI/TLY - GPI I/O] menu.

```

SETUP   :>TLY COL >GPI I/O >TALLY1 >TALLY2
GPI/TLY :>TALLY3
    
```

Setting GPI IN Functions

- PAGE 1 in the [SETUP - GPI/TLY - GPI I/O] menu determines IN or OUT for each pin. All pins are set to IN as factory default settings. Therefore, no settings from this page are required. Go to the next page.

```

GPI/TLY :GPIIN:<-    I/O ASSIGN(F2)    ->:1/3
GPI I/O : =OFF:IIIIIIII IIIIIIIII IIIIIIIII:
    
```

- Turn **[F1]**, **[F2]** and **[F3]** to set as shown below to assign the function for Example 1.

```

GPI/TLY :SEL :PIN/TRG: INPUT FUNCTION : 2/3
GPI IN  : =1 : =02Neg: =BKGD AUTO TRANS :
    
```

Pin / function pair No. 02: Pin No, Neg: Negative edge

(3) Turn **F1**, **F2** and **F3** to set as shown below to assign the function for Example 2.

```
GPI/TLY :SEL :PIN/TRG: INPUT FUNCTION : 2/3
GPI IN  : =2 : =02Neg: =DSK1 AUTO TRANS :
```

Pin / function pair No. 02: Pin No, Neg: Negative edge

(4) Go back to PAGE 1.

(5) Turn **F1** to set all GPI inputs to **ON**.

```
GPI/TLY :GPIIN:<- I/O ASSIGN(F2) ->:1/3
GPI I/O : =ON :IIIIIIII IIIIIIII IIIIIIII:
```

The GPI IN ENABLE function can be assigned to a USER button. Once this function is assigned, pressing the USER button repeatedly toggles between GPI IN **ON** (lit **orange**) and GPI IN **OFF** (lit **white**). Double-pressing the USER button opens the GPI I/O menu.

► See section 14. "USER Button" for details on how to assign the function to the USER button.

◆ GPI Outputs

Ex. 3: Outputs GPI signals from PIN 9 while BKGD transitions are being performed

To set the above GPI OUT example, proceed as follows.

(1) Open PAGE 1 in the [SETUP - GPI/TLY - GPI I/O] menu.

```
SETUP   :>SYSTEM >INPUT >OUTPUT >PANEL
MENU    :>GPI/TLY >FUNCTION>EXT I/F >STATUS
```

(2) Turn **F2** to select PIN 9, then press **F2**.

(3) Turn **F2** to select **O** (Out), then press **F2**.

```
GPI/TLY :GPIIN:<- I/O ASSIGN(F2) ->:1/3
GPI I/O : =ON :IIIIIIII OIIIIIIII IIIIIIII:
```

(4) Press the page down button twice to go to PAGE 3. Set the menu as shown below.

```
GPI/TLY :P_NO: STS : OUTPUT FUNCTION : 3/3
GPI OUT : =9 : =LOW : =BKGD TRANS STS :
```

Pin No. Active low

◆ Tally Outputs

Ex. 4: Outputs RED tallies from PIN 17 while IN01 is selected on the PGM bus.

Ex. 5: Outputs GREEN tallies from PIN 18 while IN01 is selected on the PST bus

To set the tally examples above, proceed as follows.

Assigning RED Tally Color to PGM and GREEN Tally Color to PST

(1) Display the [SETUP - GPI/TLY - TALLY COLOR] menu.

(2) Turn **F1** to select PGM, then turn **F2** to select RED.

Turn **F1** to select PST, then turn **F2** to select GRN.

```
GPI/TLY :SELECT : COLOR : : 1/1
TLY COL : =PGM : =RED : :
```

```
GPI/TLY :SELECT : COLOR : : 1/1
TLY COL : =PST : =GRN : :
```

Assigning Tallies to Pins

(1) Open PAGE 1 in the [SETUP - GPI/TLY - GPI I/O] menu.

(2) Turn **F2** to select PIN 17, and press **F2**.

(3) Turn **F2** to select O (Out), then press **F2**.

(4) Set PIN 18 to Out in the same way.

```
GPI/TLY :GPIIN:<- I/O ASSIGN(F2) ->:1/3
GPI I/O : =ON :IIIIIIII OIIIIIII OOIIIIIII:
```

(5) Press the page down button twice to go to PAGE 3 and set the menu as shown below.

```
GPI/TLY :P_NO: STS : OUTPUT FUNCTION : 3/3
GPI OUT : =17: =LOW : =RED TALLY-IN01
```

```
GPI/TLY :P_NO: STS : OUTPUT FUNCTION : 3/3
GPI OUT : =18: =LOW : =GREEN TALLY-IN01:
```

Pin No.

Active low

20-1-3. Sending Tally Signals to Tally Units

Up to three tally units can be connected to the switcher by cascading them through an RS-422 port.

Two types of Tally Units, Open Collector and Relay types, can be used.

► See the "HVS-TALOC/TALR20/32 Operation Manual" for details on tally unit setup.

Communication Settings for Tally Units

Set the Communication parameters before setting up tally signals. Tally Units are connected to RS-422 (2) in this example.

- (1) Open the [SETUP - SYSTEM - RS-422] menu.
- (2) Turn **F1** to select **PORT2**.
- (3) Turn **F2** to select **TALLY**. Set the parity to **EVEN**. The baud rate is automatically set according to the tally unit.

```
SYSTEM :SELECT : FUNC : BAUD :PARITY : 1/1
RS-422 : =PORT2: =TALLY: =38400: =EVEN :
```

- (4) Restart the switcher.
► See section 19-1. "Rebooting System."

Tally Unit Settings

The following example sets the following tally signal for TALLY 1.

The switcher and Tally units share the same tally color settings. (See the previous page.)

Example	Pin	Description
TALLY 1	1	Outputs RED tallies while IN01 is selected on the PGM bus.

- (1) Open the [SETUP - GPI/TLY] menu.
- (2) Turn **F1** to select TALLY1 and press **F1** to display the [SETUP - GPI/TLY - TALLY1] menu.

```
SETUP :>TLY COL >GPI I/O >TALLY1 >TALLY2
GPI/TLY :>TALLY3
```

- (3) Select the pin number and set the function as shown below.
Turn **F1** to set ENABLE to ON to activate all tallies in TALLY1.

```
GPI/TLY :ENABLE :P NO : FUNCTION : 1/1
TALLY1 : =ON : =1 : =RED TALLY-IN01
```

20-1-4. GPI / Tally Function List

◆ GPI IN functions

FUNCTION setting	Description
NOT USED	No function is assigned.
BKGD AUTO TRANS	Performs Background AUTO transitions.
KEY1 AUTO TRANS KEY2 AUTO TRANS	Performs KEY1-2 AUTO transitions using background AUTO buttons.
DSK1 AUTO TRANS DSK2 AUTO TRANS	Performs DSK1-2 transitions using DSK1 and DSK2 transition buttons.
NEXT AUTO TRANS	Performs AUTO transitions for the NEXT AUTO TRANSITION bus set in the transition block.
BLACK AUTO TRANS	Performs BLACK transitions.
BKGD CUT TRANS	Performs Background CUT transitions.
KEY1 CUT TRANS KEY2 CUT TRANS DSK1 CUT TRANS DSK2 CUT TRANS	Performs KEY / DSK CUT transitions.
TRANS-TYPE BKGD-WIPE	Changes the background transition type to WIPE.
TRANS-TYPE BKGD-MIX	Changes the background transition type to MIX.
TRANS-TYPE BKGD-CUT	Changes the background transition type to CUT.
TRANS-TYPE KEY1-WIPE TRANS-TYPE KEY2-WIPE	Changes KEY transitions to WIPE type.
TRANS-TYPE KEY1-MIX TRANS-TYPE KEY2-MIX	Changes KEY transitions to MIX type.
TRANS-TYPE KEY1-CUT TRANS-TYPE KEY2-CUT	Changes KEY transitions to CUT type.
TRANS-TYPE DSK1-MIX TRANS-TYPE DSK2-MIX	Changes DSK transitions to MIX type.
TRANS-TYPE DSK1-CUT TRANS-TYPE DSK2-CUT	Changes DSK transitions to CUT type.
KEY1-UTRS SCALER KEY1-UTRS SLIDE-L/R/T/B KEY1-UTRS WIPE-L/R/T/B	Performs KEY1 User transitions.
KEY2-UTRS SCALER KEY2-UTRS SLIDE-L/R/T/B KEY2-UTRS WIPE-L/R/T/B	Performs KEY2 User transitions.
DSK1-UTRS SCALER DSK1-UTRS SLIDE-L/R/T/B DSK1-UTRS WIPE-L/R/T/B	Performs DSK1 User transitions.
DSK2-UTRS SCALER DSK2-UTRS SLIDE-L/R/T/B DSK2-UTRS WIPE-L/R/T/B	Performs DSK2 User transitions.
USER BUTTON1-8	Performs the function assigned to USER buttons.
STILL STORE1-2	Performs still store.
MACRO.00 PLAY to MACRO.29 PLAY	Executes macros.
XPT PGM BLACK	Selects BLACK for the PGM bus.
XPT PGM IN01-14	Selects a primary input for the PGM bus.
XPT PGM STILL1-2	Selects a still (fill) for the PGM bus.
XPT PGM STL KEY1-2	Selects a still (key) for the PGM bus.
XPT PGM MATT1-2	Selects a matte for the PGM bus.
XPT PGM COLORBAR	Selects COLORBAR for the PGM bus.
XPT PGM CKFIL	Selects Chromakey (Fill) for the PGM bus.
XPT PGM CKKEY	Selects Chromakey (Key) for the PGM bus.
XPT PGM SUB EFF1-2	Selects a SUB EFFECT channel for the PGM bus.

XPT PGM RT XPT01-64	Selects a router crosspoint for the PGM bus. This function is available when ENABLE is set to ON in the [SETUP-EXT IF-RTR LINK] (1/2) menu.
XPT PST BLACK	Selects BLACK for the PST bus.
XPT PST IN01-14	Selects a primary input for the PST bus.
XPT PST STILL1-2	Selects a still (fill) for the PST bus.
XPT PST STL KEY1-2	Selects a still (key) for the PST bus.
XPT PST MATT1-2	Selects a matte for the PST bus.
XPT PST COLORBAR	Selects COLORBAR for the PST bus.
XPT PST CKFIL	Selects Chromakey (Fill) for the PST bus.
XPT PST CKKEY	Selects Chromakey (Key) for the PST bus.
XPT PST SUB EFF1-2	Selects a SUB EFFECT channel for the PST bus.
XPT PST RT XPT01-64	Selects a router crosspoint for the PGM bus. This function is available when ENABLE is set to ON in the [SETUP-EXT IF-RTR LINK] (1/2) menu.
XPT AUX1-8 TRANS ENABLE	Toggles AUX1-8 Crossfade transitions On and Off.
XPT AUX1-8 BLACK	Selects BLACK for an AUX bus.
XPT AUX1-8 IN01-14	Selects a primary input for an AUX bus.
XPT AUX1-8 STILL1-2	Selects a still (fill) for an AUX bus.
XPT AUX1-8 STILLK1-2	Selects a still (key) for an AUX bus
XPT AUX1-8 MATT1-2	Selects a matte for an AUX bus.
XPT AUX1-8 COLORBAR	Selects COLORBAR for an AUX bus.
XPT AUX1-8 CKFIL	Selects Chromakey (Fill) for an AUX bus.
XPT AUX1-8 CKKEY	Selects Chromakey (Key) for an AUX bus.
XPT AUX1-8 SUB EFF1-2	Selects a SUB EFFECT channel for an AUX bus.
XPT AUX1-8 RT XPT01-64	Selects a router crosspoint for an AUX bus. This function is available when ENABLE is set to ON in the [SETUP-EXT IF-RTR LINK] (1/2) menu.
XPT AUX1-8 PGM	Selects PGM for an AUX bus.
XPT AUX1-8 PREV	Selects PREV for an AUX bus.
XPT AUX1-8 CLEAN	Selects CLEAN for an AUX bus.
XPT AUX1-8 KEYOUT	Selects KEY for an AUX bus.
XPT AUX1-8 MV	Selects the MV output for an AUX bus.
EVENT RECALL No.0-9	Recalls events.
EVENT PAGE No. 0-9	Selects an event memory page.
MV USER PRESET1-8	Recalls a multiviewer screen layout.

◆ **GPI OUT function**

FUNCTION setting	Description
NOT USED	No function is assigned
GPI OUTPUT01-08	These functions are used in conjunction with USER buttons (GPI OUTPUT1-8 Push/Toggle). Push: Continues to output GPI pulses while the button is pressed. Toggle: Toggles GPI pulse On/Off.
BKGD TRANS STS	Outputs pulse while background transitions are processed.
KEY1 TRANS STS KEY2 TRANS STS DSK1 TRANS STS DSK2 TRANS STS	Outputs pulse while KEY/DSK transitions are processed.
BKGD AUTO TRANS	Outputs pulse while background AUTO transitions are processed.
KEY1 AUTO TRANS KEY2 AUTO TRANS DSK1 AUTO TRANS DSK2 AUTO TRANS	Outputs pulse while KEY/DSK AUTO transitions are processed.
TRS TYPE BKGD-CUT	Outputs pulse while the BKGD transition type is set to CUT.
TRS TYPE KEY1-CUT TRS TYPE KEY2-CUT	Outputs pulse while the KEY transition type is set to CUT.
TRS TYPE DSK1-CUT TRS TYPE DSK2-CUT	Outputs pulse while the DSK transition type is set to CUT.
TRS TYPE BKGD-MIX	Outputs pulse while the BKGD transition type is set to MIX.
TRS TYPE KEY1-MIX TRS TYPE KEY2-MIX	Outputs pulse while the KEY transition type is set to MIX.
TRS TYPE DSK1-MIX TRS TYPE DSK2-MIX	Outputs pulse while the DSK transition type is set to MIX.
TRS TYPE BKGD-WIPE	Outputs pulse while the BKGD transition type is set to WIPE.
TRS TYPE KEY1-WIPE TRS TYPE KEY2-WIPE	Outputs pulse while the KEY transition type is set to WIPE.

◆ **TALLY function**

FUNCTION setting		Description
KEY1 ON TLY KEY2 ON TLY DSK1 ON TLY DSK2 ON TLY		Outputs tally signal when KEY or DSK is on the background video.
FAN ERROR ALARM		Outputs power or fan alarm.
XT100	PS1-2 ERROR ALARM	
	ALL ALARM	
RED TALLY-BLACK		Outputs a red tally when the specified signal is sent to the red (tally color) bus.
RED TALLY-IN01-14		
RED TALLY-STIL1-2		
RED TALLY-STILK1-2		
RED TALLY-MATT1-2		
RED TALLY-CKFIL		
RED TALLY-CKKEY		
RED TALLY-EFF1-2		
RED TALLY RX01-64 *		
RED TALLY-PGM		
RED TALLY-PREV		
RED TALLY-CLN		
GREEN TALLY-BLACK		
GREEN TALLY-IN01-14		
GREEN TALLY-STIL1-2		
GREEN TALLY-STILK1-2		
GREEN TALLY-MATT1-2		
GREEN TALLY-CKFIL		
GREEN TALLY-CKKEY		
GREEN TALLY-EFF1-2		
GREENTALLY RX01-64 *		
GREEN TALLY-PGM		
GREEN TALLY-PREV		
GREEN TALLY-CLN		
COL1-6 TALLY-BLACK		Outputs a COLOR1 tally when the specified signal is sent to the COLOR1 bus. Outputs tallies in the same way as for COLOR2 to COLOR6.
COL1-6 TALLY-IN01-14		
COL1-6 TALLY-STIL1-2		
COL1-6 TALLY-STILK1-2		
COL1-6 TALLY-MATT1-2		
COL1-6 TALLY-CKFIL		
COL1-6 TALLY-CKKEY		
COL1-6 TALLY-EFF1-2		
COL1-6 TALLY RX01-64 *		
COL1-6 TALLY-PGM		
COL1-6 TALLY-PREV		
COL1-6 TALLY-CLN		
AUX1 to 8 TRANS ENABLE		

* This function is available when ENABLE is set to ON in the [SETUP-EXT IF-RTR LINK] (1/2) menu.

20-2. VTR / VDCP Control

The switcher can control video tape or video disk recorders via RS-422 using the VTR or VDCP protocol. Up to 2 channels (two devices) are available. Connect a device to a desired RS-422 port, configure the port and select a channel for VTR or VDCP following the procedures in this chapter.

System Configuration Example

- 1) Connect an HVS-XT110 to a VTR using an RS-422 port and configure the port.
 - ▶ See section 20-2-1.
- 2) Assign a VTR channel to the RS-422 port.
 - ▶ See section 20-2-2.
- 3) Control the VTR using the VTR/VDCP menu (see section 20-2-3) or by using USER buttons (see section 14. "USER Buttons.")

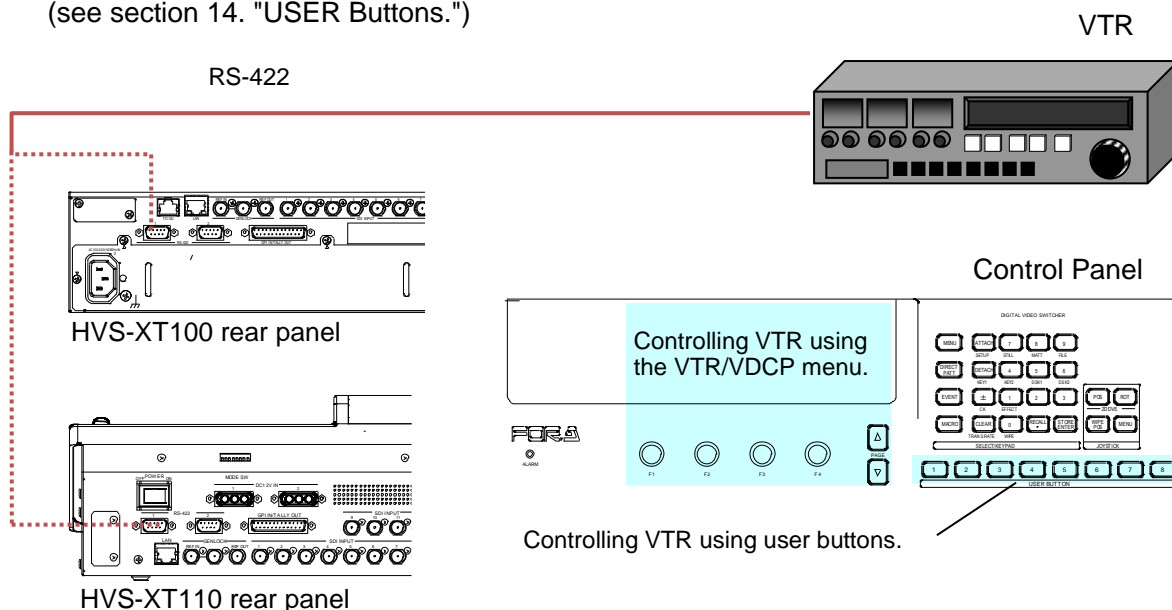

20-2-1. RS-422 Port Settings (VTR/VDCP)

- (1) Press **MENU**, then **SETUP** in the SELECT/KEYPAD block to display the [SETUP] top menu.
- (2) Turn **F1** to select **SYSTEM**. Press **F1** to go to the [SETUP - SYSTEM] menu.
- (3) Turn **F1** to select **RS-422**. Press **F1** to go to the [SETUP - SYSTEM - RS-422] menu.
- (4) When connecting a VTR to RS-422 (1) port, set the menu as shown below.
If your device supports VDCP protocol, set **VDCP1** instead of **VTR1** under **FUNC**.

SYSTEM	: SELECT	: FUNC	: BAUD	: PARITY	: 1/1
RS-422	: =PORT1	: =VTR1	: =38400	: =ODD	:

- (5) Change **BAUDRATE** and **PARITY** using **F3** or **F4**, if needed.

In some cases, setting BAUDRATE to 38400 may cause the system to malfunction. In such cases, re-establish the connection with either of the options below.

- (a) Set **Stop Bit** to **1.5** or **2** in the target device.
- (b) Set **Baudrate** to **39300** in the switcher.

- (6) Reboot the switcher.
 - ▶ See section 19-1. "Rebooting System."

20-2-2. Controlling the VTR

◆ Selecting a Channel for Control

(1) Open the [SETUP - EXT I/F - VTR/VDCP] menu.

(2) Select a VTR (VTR1 or VTR2) or VDCP (VDCP1 or VDCP2) channel under **SELECT**.

```
EXT I/F :SELECT : (STOP/00:00:00:00): 1/4
VTR/VDCP: =VTR1 : DRCT REC=OFF :
```

```
EXT I/F :SELECT : (STOP/00:00:00:00): 1/7
VTR/VDCP: =VDCP1: DRCT REC=OFF :
```

(3) When the connection to the device is established, the device status and current time code value will be displayed

◆ Selecting the VDCP Type

Select a type when connecting to a VDCP device.

(1) Open the [SETUP - EXT I/F - VTR/VDCP] menu and go to PAGE 6.

```
EXT I/F : MODEL : : 6/7
VTR/VDCP: =Mira : :
```

(2) Turn **F1** to select the VDCP model type. (See the table below.)

MODEL setting	Description
Mira	Abekas Mira Servers
HVS-5ECD	FOR-A HVS-5ECD

◆ Playing and Recording on the VTR

Playback and Recording on the VTR can be controlled from the switcher.

Open the [SETUP - EXT I/F - VTR/VDCP] menu and go to PAGE 2.

```
EXT I/F : (STOP/00:00:00:00): 2/4
VTR/VDCP: >STOP : >REC : >PLAY : >FF :
```

Playing on the VTR

Press **F3** to start playing.

Press **F3** again to pause playback. Press **F1** to stop playback.

Recording on the VTR

Press **F3** while holding down **F2** to start recording.

Press **F1** to stop recording.

- ▶ For details on VTR operation, see section 20-2-3. "Playback and Recording."
- ▶ For details on VDCP operation, see section 20-2-4 "VDCP Operation."
- ▶ Several VTR/VDCP operation and selection procedures can be assigned to USER buttons. See section 14. "USER Buttons" for details.

20-2-3. Playback and Recording

Four pages of the [VTR/VDCP] menu contain the following control commands.

EXT I/F :SELECT :	(STOP/00:00:00:00):	1/4
VTR/VDCP: =VTR1 :	DRCT REC=OFF	:

EXT I/F :	(STOP/00:00:00:00):	2/4
VTR/VDCP: >STOP :	>REC :	>PLAY :
		>FF :

EXT I/F :	(STOP/00:00:00:00):	3/4
VTR/VDCP: >CUEUP:	TC=00:00:00:00	

EXT I/F : SHTL :	VAR :	(STOP:00:00:00:00):	4/4
VTR/VDCP: >0 :	>0.0 :	>STEP-R :	>STEP-F :

Item	F1 - F4 control		Description	
1/4	SELECT	F1	Turn	Selects a VTR or VDCP channel for control.
	DRCT REC (DIRECT REC)	F3	Turn	Sets DIRECT REC mode to ON or OFF.
2/4	STOP	F1	Press	Stops the device operation.
	REC	F2+ F3	Press	Starts recording by pressing F3 while holding down F2 when DIRCT REC is Off.
		F2	Press	Starts recording by pressing F2 when DIRECT REC is ON.
	PLAY/PAUSE	F3	Press	Starts playback. Pauses playback while playing back video.
	REW/FF	F4	Press	Rewinds or fast-forwards tapes or other video storage media.
F4		Turn	Switches between REW and FF.	
3/4	CUE UP	F1	Press	Cues up to a location specified by time code value. Set the time code value in the following way.
	TC Input	F3	Press & turn	1) Press F3 to enable TC Input mode. 2) Enter a value by turning F3 or using the keypad. The time code for CUE UP should be set in hh/mm/ss/ff format. 3) Press F3 to set the time code.
			Turn	Increases or decreases the time code value on a per-frame basis by turning F3 without pressing F3 beforehand, if time code is already set.
4/4	SHTL	F1	Press	Plays the device to shuttle mode.
		F1	Turn	Selects the shuttle mode speed.
	VAR	F2	Press	Plays the device to variable mode.
		F2	Turn	Selects the variable mode speed.
	STEP-R	F3	Press	Reverses the current time code by one frame.
	STEP-F	F4	Press	Advances the current time code by one frame.

* VTR control does not support CTL timecode. TC display, CUE UP, STEP-R, and STEP-F do not work properly if the connected device uses CTL timecode.

20-2-4. VDCP Operation

In addition to the commands listed in section 20-2-3. "Playback and Recording," the switcher can obtain a CLIP List stored in the connected VDCP device and play video specifying IN- and OUT-points. Apart from Clips in the VDCP device, the switcher can store two Playlists, in which the switcher's own information such as IN and OUT points are contained.

- Each Playlist contains the following information.
 - CLIP ID (ID of the selected Clip stored in the connected device.)
 - IN point, OUT point and Duration values
- The following operation procedures are available:

Creating Playlists
Specifying an IN-point and OUT-point for trimming
Jumping to an IN-point
Jumping to a location specified by time code
Changing CLIP ID (CLIP ID in the connected device also changes accordingly.)
Deleting Clips (Also deleted from connected device.)
Copying and clearing Playlists

- The switcher can create new Clips
 - ▶ See page 189 "Creating New Clips."

Note that some VDCP devices may not support all commands available on the switcher. In such case, unsupported commands cannot be executed from the switcher.

◆ Creating Playlists

Selecting a Playlist

- (1) Display the [SETUP - EXT I/F - VTR/VDCP] menu.
- (2) Press the page down button to go to PAGE 5.
- (3) Select **1** (Playlist 1) or **2** (Playlist 2) under **SELECT**.

```
EXT I/F :SELECT :                :FUNC  : 5/7
VTR/VDCP:=1      :>ID SET:>TC SET: >COPY :
```

Selecting a CLIP ID for the Playlist

- (1) Press **F2** in PAGE 5 of the [SETUP - EXT I/F - VTR/VDCP] menu to display the [CLIP] menu.

```
EXT I/F :SELECT :                :FUNC  : 5/7
VTR/VDCP:=1      :>ID SET:>TC SET: >COPY :
```

- (2) The [CLIP] menu will display the Clip List stored in the connected device. Turn **F1** to select the CLIP ID of the desired Clip from the list and then press **F1**.

```
VTR/VDCP:CLIP0001 :                : 1/1
CLIP    :CLIP0002  :>RENAME :>CANCEL :
```

```
:CLIP0003 :
:CLIP0004 :
:CLIP0005 :
: |       :
```

Select a CLIP ID from the CLIP List. Up to 30 entries (up to 8 characters for each) can be displayed.

- (3) Once a CLIP ID is selected, the display automatically returns to the previous menu. Check that the selected CLIP ID is displayed in the upper row. To cancel the operation, press **F4**.

```
EXT I/F :SELECT : CLIP0001 :FUNC : 5/7
VTR/VDPC:=1 :>ID SET:>TC SET: >COPY :
```

Setting IN and OUT points

IN-point and OUT-point or Duration settings for the Clip can be set and stored in Playlists.

- (1) Go to PAGE 5 of the [VTR/VDPC] menu. Press **F3** to display the [TC SET] menu.

```
EXT I/F :SELECT : :FUNC : 5/7
VTR/VDPC:=1 :>ID SET:>TC SET: >COPY :
```

- (2) Turn **F1** to select **IN**.

```
VTR/VDPC:00:00:01:00 (STOP/00:05:00:00) : 1/2
TC SET :>IN :>SET :>CUE UP : >OK: L=1
```

- (3) Enter a time code value for an IN point to the left in the upper row of the menu display. There are 3 methods of input. (See the table below.) The current status and time code are displayed to the right in the menu.

Input method			Description
Copy and paste the current time code. (MARK IN/MARK OUT)	F1	Press	Press F1 . The current time code is copied into the time code field.
Adjust time code on a per-frame basis	F2	Turn	Turn F2 to increase or decrease the time code on a per-frame basis.
Enter time code using the keypad	F2	Press	Press F2 . When the lights in the keypad turn on, enter the value. Press ENTER to apply the setting.

- (4) Turn **F1** to select **OUT** or DUR(duration).

```
VTR/VDPC:00:00:20:00 (STOP/00:05:00:00) : 1/2
TC SET :>OUT :>SET :>CUE UP: >OK : L=1
```

- (5) Set the OUT-point or Duration in the same way as those for IN-points.
 (6) After settings are complete, press **F4** to return to the previous menu.

```
Pressing F3 (CUE UP) can jump to the specified time code position. This is convenient for checking IN point images.
```

Checking the Playlist Data

Press the page down button to go to PAGE 2 of the [TC SET] menu.

This menu displays the Playlist data: IN point, OUT point, current time code, duration and playlist number.

```
VTR/VDPC:IN /00:00:01:00 TC /00:00:05:00: 2/2
TC SET :OUT/00:00:20:00 DUR/00:00:19:00: L=1
```

◆ Jumping to an IN point or a Specified Position

Jumping to the IN-Point

- (1) Display PAGE 5 of the [SETUP - EXT I/F - VTR/VDACP] menu.
- (2) Set 1 or 2 under SELECT to select Playlist 1 or 2.
- (3) Press **F3** to display the [TC SET] menu.

```
EXT I/F :SELECT :                :FUNC   : 5/7
VTR/VDACP:=1      :>ID SET:>TC SET: >COPY :
```

- (4) Press **F3** (CUE UP) to jump to the IN point.

```
VTR/VDACP:00:00:01:00 (STOP/00:05:00:00) : 1/2
TC SET   :>IN      :>SET    :>CUE UP : >OK : L=1
```

- (5) Press **F4** (OK) to return to the previous menu.

Jumping to the Specified Point

- (1) Display PAGE 3 of the [SETUP - EXT I/F - VTR/VDACP] menu.
- (2) Press **F3** to set a timecode and press **ENTER**. Or turn **F3** to increase/decrease frames, then press **F3**.
- (3) Press **F1** (CUE UP) to jump to the specified point.

```
EXT I/F :                (----/00:00:00:00) : 3/7
VTR/VDACP: >CUEUP:      TC=00:00:00:00   :
```

◆ Changing CLIP ID (Mira only)

- (1) Press **F2** in PAGE 5 of the [SETUP - EXT I/F - VTR/VDACP] menu to display the [CLIP] menu.

```
EXT I/F :SELECT :                :FUNC   : 5/7
VTR/VDACP:=1      :>ID SET:>TC SET: >COPY :
```

- (2) The [CLIP] menu displays the Clip List stored in the connected device. Turn **F1** to select a CLIP ID.

```
VTR/VDACP:CLIP0001      :                : 1/1
CLIP     :CLIP0002     :>RENAME :>CANCEL :
```

- (3) Turn **F3** to select **RENAME**. Then press **F3** to enter RENAME mode.

```
VTR/VDACP:CLIP0001      :                : 1/1
CLIP     :CLIP0002     :>RENAME :>CANCEL :
```

- (4) Turn **F1** to select a position in the name string, then turn **F2** to select a character to change. In the same way, set a new name on a per-character basis. Press **F3** to apply the new name. Up to 8 alphanumeric characters can be used.

◆ **Deleting Clips (Mira only)**

- (1) Refer to "Changing CLIP ID" above to select a Clip.
- (2) Turn **F3** to select **DELETE** and then press **F3**.

VTR/VDPC:CLIP0001	:		:	1/1
CLIP	:	CLIP0002	:	>DELETE :>CANCEL :

- (3) Turn **F3** to select **OK**. Then press **F3** to delete the Clip. The Clip in the connected device is also deleted. To cancel the operation, select **CNCL** and press **F3**.

◆ **Clearing Playlists**

- (1) Display PAGE 5 of the [SETUP - EXT I/F - VTR/VDPC] menu.
- (2) Set 1 or 2 under **SELECT** to select Playlist 1 or 2.
- (3) Turn **F4** to select **CLEAR**, then press **F4**.

EXT I/F :SELECT :		:FUNC :	5/7
VTR/VDPC:=1	:	>ID SET:>TC SET: >	CLEAR:

- (4) Turn **F3** to select **OK**. Then press **F3** to clear the playlist data. To cancel the operation, select **CNCL** and press **F3**.

◆ **Copying Data between two Playlists**

- (1) Display PAGE 5 of the [SETUP - EXT I/F - VTR/VDPC] menu.
- (2) Set 1 or 2 under **SELECT** to select Playlist 1 or 2 for copying data.
- (3) Turn **F4** to select **COPY**, and then press **F4**.

EXT I/F :SELECT :		:FUNC :	5/7
VTR/VDPC:=1	:	>ID SET:>TC SET: >	COPY :

- (4) Turn **F1** to select a copy destination (Playlist 1 or 2).

EXT I/F :SELECT :		:FUNC :	5/7
VTR/VDPC:=2	:	>ID SET:>TC SET: >	PASTE:

- (5) Turn **F4** to select **PASTE**, and then press **F4**. The data is copied from one playlist to the other.

◆ **Creating New Clips (Recording using VDCP)**

Recording video and creating new Clips are possible. They are stored in the connected device. To create a new clip, proceed as follows:

- (1) Display PAGE 7 of the [SETUP - EXT I/F - VTR/VDPC] menu.
- (2) Press **F3** to change to ID input mode.
- (3) To enter a new CLIP ID, set a character for each cell: Turn **F3** to select the first cell, then turn **F4** to select a character for it. Repeat this process until the new ID is set. Press **F3** to apply the new ID.

EXT I/F :REC DURATION :REC ID:	NEW0001	:	7/7
VTR/VDPC:=00:00:15:00	:	>RENAME :	>REC :

- (4) To set recording duration, turn **F1** to enter values. The procedure for setting durations is almost the same as that for setting time codes.
 ▶ See page 186 "Creating Playlists."

```
EXT I/F :REC DURATION :REC ID:NEW0001      : 7/7
VTR/VDCP:=00:00:15:00 :>RENAME      : >REC      :
```

- (5) If **DIRECT REC** is set to **ON**, press **F4** to start recording.
 If **DIRECT REC** is set to **OFF**, press **PLAY** while holding down **REC** in PAGE 2 to start recording.
 Recording will automatically stop when the duration time is elapsed.

```
EXT I/F :REC DURATION :REC ID:NEW0001      : 7/7
VTR/VDCP:=00:00:15:00 :>RENAME      : >REC      :
```

Setting DIRECT REC to ON or OFF

- (1) Press the page up button to go to PAGE 1 of the [VTR/VDCP] menu.
 (2) Turn **F3** to set **DIRECT REC** to ON or OFF.

```
EXT I/F :SELECT      :      (STOP:00:00:00:00): 1/7
VTR/VDCP:=VDCP1     : DRCT REC=ON           :
```

20-3. Router Control

The switcher can connect and control a router. Router crosspoint switches can be performed on the switcher's control panel. The router control is based on the HARRIS Pass-Through protocol. In addition to router control, video titles on the router can be handed to the switcher if a FOR-A MFR series router is connected.

Manageable number of sources, destinations and levels are:

Level	16 (8 for MFR series routers)
Source	1,024
Destination	256

Connect a router to an RS-422 port (1 or 2) on the HVS-XT110 using an RS-422 straight-through cable. Then configure the RS-422 port for router control. Crosspoint switches can be performed using USER, AUX1-4 and KEY/AUX bus buttons.

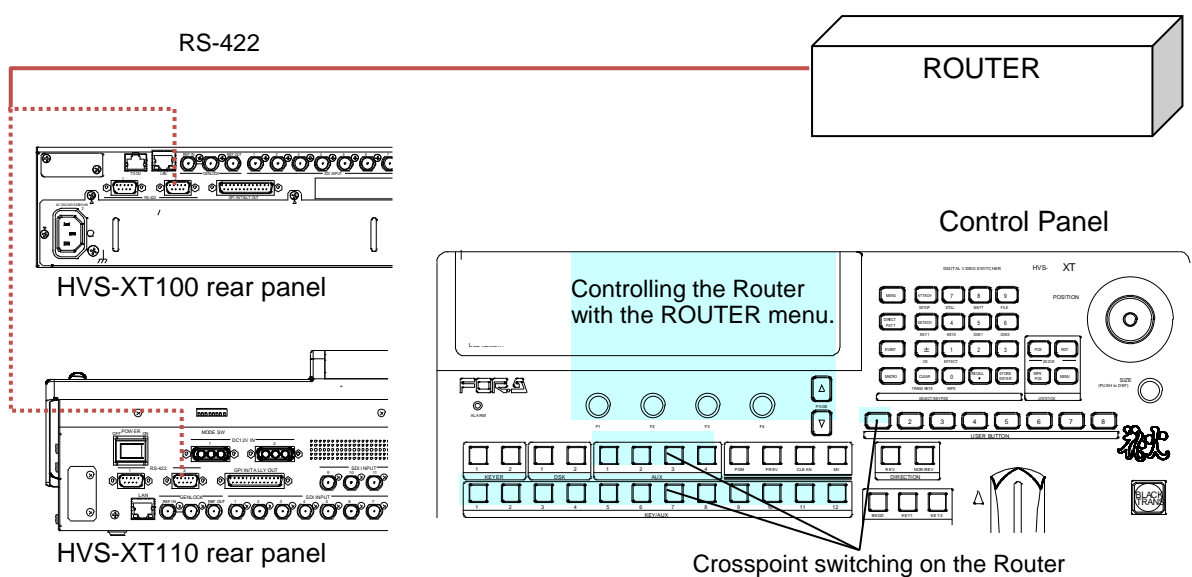

20-3-1. RS-422 Port Settings

- (1) Open the [SETUP - SYSTEM - RS-422] menu.
- (2) Set the menu as shown below. (Set to **PORT2** if connecting the router to the RS-422(2) port. The BAUD rate may vary depending on routers.)

SYSTEM	: SELECT	: FUNC	: BAUD	: PARITY	: 1/1
RS-422	: = PORT2	: = ROUTER	: = 57600	: = NONE	:

In some cases, setting BAUDRATE to 38400 may cause the system to malfunction. In such cases, re-establish the connection with either of the options below.

- (a) Set **Stop Bit** to **1.5** or **2** in the target device.
- (b) Set **Baudrate** to **39300** in the switcher.

- (3) After settings are complete, reboot the switcher.
 - ▶ See section 19-1. "Rebooting System."

20-3-2. Setting MFR Link

MFR Link is enabled only when connecting to FOR-A MFR series routers.

When the title link display is set to **ON**, the switcher accepts video titles with video signals from a router and displays them on the control panel according to the associated crosspoint switches on the router.

(1) Open the [SETUP - EXT I/F - ROUTER] (6/6) menu.

```
EXT I/F : LINK : CHARA :SELECT :DISPLAY: 6/6
ROUTER  : =MFR : =SHORT: =IN01 : =ON   :
```

(2) Turn **F1** to select **MFR** and then press **F1**.

(3) Turn **F2** to select a name link type from **SHORT**, **LONG** and **BOTH**. Both types of names are stored in the switcher.

(4) Title link should be set respectively for each video. First, turn **F3** to select a video, then turn **F4** to set the title link display to **ON** or **OFF**.

20-3-3. Crosspoint Switches Using the Menu

To execute the following commands:

```
Select a router level.
Connect Source channel 2 to Destination channel 1.
Connect Source channel 4 to Destination channel 2.
```

Proceed as follows:

(1) Display the [SETUP - EXT I/F - ROUTER] (2/6) menu.

(2) Turn **F1** to select a level. Press **F1** or press **ENTER** on the keypad to confirm the setting.

(3) Turn **F2** to select **1** under **DEST** (destination). The currently connected source is displayed under **SRC** (source).

(4) Turn **F3** to select **2**, then press **F3** to switch the source. The HVS-XT110 sends the crosspoint switch command to the router.

(5) The switcher displays **2** under **SRC** after receiving a successful response from the router.

```
EXT I/F : LEVEL : DEST : SRC : : 2/6
ROUTER  : =1   : =1   : =2   : :   :
```

(6) In the same way, select **2** under **DEST** and **4** under **SRC**.

```
EXT I/F : LEVEL : DEST : SRC : : 2/6
ROUTER  : =1   : =2   : =4   : :   :
```

20-3-4. Crosspoint Switches with Control Buttons (Setup)

Crosspoint switches on the control panel can be performed using USER, **AUX1** to **AUX4** buttons and KEY/AUX bus buttons. Before switching crosspoints, these buttons should be set to control a router. The procedure below uses **USER 1** as an example.

Assigning the Router Control ON/OFF function to USER 1

- (1) Display the [SETUP - PANEL - USER BTN] (1/2) menu.
- (2) Set the menu as shown below, then press **F3**. **USER 1** allows you to enable or disable the router control buttons (**AUX1** to **AUX4** and KEY/AUX bus buttons).

USER	: SELECT:	TYPE	: FUNC(F3)
BUTTON	: = OU-1 :	= OTHER :	= ROUTER ENABLE

- ▶ See section 14. "USER Buttons" for details on user button assignments.

◆ Router Control Button Settings

Router control level and button settings are set as shown below as factory default settings.

Level to be controlled	Level 1
AUX1-4 buttons	Destination 1-4
KEY/AUX bus buttons 1-12	Source 1-12

To Change Destination and Source Button Assignments

- (1) Open [SETUP - EXT I/F - ROUTER] menu PAGE 1.
- (2) To assign Destination 13 to AUX 3, turn **F1** to select **3**, then turn **F2** to select **13**.

EXT I/F	: DST	BTN:	DST CH	: SRC	BTN:	SRC CH	: 1/6
ROUTER	: = 3	:	= 13	: =1	:	=1	:

- (3) To assign Source 10 to KEY/AUX bus button 5, turn **F3** to select **5**, then turn **F4** to select **10**.

EXT I/F	: DST	BTN:	DST CH	: SRC	BTN:	SRC CH	: 1/6
ROUTER	: =2	:	=12	: = 5	:	= 10	:

To Change Control Level

- (1) Go to PAGE 2 in the [SETUP - EXT I/F - ROUTER] menu.
- (2) Turn **F1** to select a level under **LEVEL**.

EXT I/F	: LEVEL	: DEST	: SRC	:	:	: 2/6
ROUTER	: = 2	: =1	: =1	:	:	:

20-3-5. Crosspoint Switches with Control Buttons (Execution)

- ◆ Assume that router functions are assigned to the router control buttons as shown in the table below.

Router control ON/OFF	USER 1 on the control panel
Destination channels 1 to 4	AUX 1 to AUX 4
Source channels 1 to 8	KEY/AUX bus buttons 1 to 8

To execute the following commands:

Connect Source channel 2 to Destination channel 1.
Connect Source channel 4 to Destination channel 2.

Proceed as follows:

- (1) Press **USER1** to enable the router control buttons.
- (2) Press **AUX1** to select Destination 1. The source channel button currently connected to Destination 1 will light orange.
- (3) Press **2** on the KEY/AUX bus to change the source channel to 2. The HVS-XT110 sends the crosspoint switch command to the router. The bus button **2** on the KEY/AUX will turn orange after having received a successful response from the router.

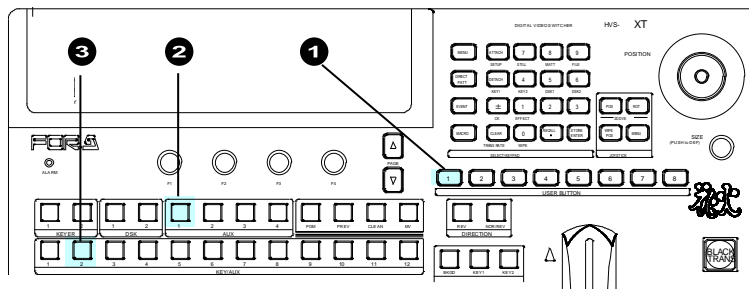

- (4) In the same way, press **AUX2**.
- (5) Then press **4** on the KEY/AUX bus.

20-3-6. Displaying Destination / Source Settings

The switcher can obtain and display the current destination / source settings (crosspoints) on the router as in the procedure below.

- (1) Go to PAGE4 in the [SETUP - EXT I/F - ROUTER] menu.
- (2) Turn **F1** to select a level.

EXT I/F	: LEVEL	: XPT	: PRESET	:	:	4/6
ROUTER	: = 1	: >	: >	:	:	

- (3) Press **F2**. The current crosspoint pairs (**Destination - Source**) on the router are listed as shown below: Up to 6 pairs can be displayed per menu page. Use the page up or down button to move among pages.

ROUTER	: 1-1	2-2	3-3	:	:	1/XX
XPT	: 4-4	5-5	6-6	:	>BACK	:
	7-7	8-8	9-9			
	10-10	11-11	12-12			

20-3-7. Saving and Loading Crosspoints

A set of all crosspoints (destination and source pairs) on the router can be saved to and loaded from the switcher.

Saving Crosspoints

(1) Go to PAGE5 in the [SETUP - EXT I/F - ROUTER] menu.

EXT I/F	:	LOAD	:	SAVE	:		:	5/6
ROUTER	:	>	:	>	:		:	

(2) Press **F2**. The switcher will start to store the data and the message "DATA SAVING" is displayed on the display.

EXT I/F	:	LOAD	:	SAVE	:		:	5/6
ROUTER	:		:		:	DATA SAVING	:	

(3) After saving is complete, the message "COMPLETED" is displayed.

Loading Crosspoints

(1) Go to PAGE5 in the [SETUP - EXT I/F - ROUTER] menu.

(2) Press **F1** to load the crosspoints from the memory. The message "DATA LOADING" is displayed during processing.

EXT I/F	:	LOAD	:	SAVE	:		:	5/6
ROUTER	:		:		:	DATA LOADING	:	

(3) After loading is complete, the message "COMPLETED" is displayed.

20-3-8. Simultaneous Switching Using Take

Multiple crosspoints (destination/source pairs) can be switched simultaneously in the menu using stored crosspoint data.

Setting Crosspoints

- (1) Go to PAGE 3 in the [SETUP - EXT I/F - ROUTER] menu.
- (2) Turn **F1** to select a level.
- (3) Turn **F2** to select a destination. If a source to be paired has been set, the source channel number is displayed. DEST1 and SRC1 are paired in the menu example below.

```
EXT I/F : LEVEL : DEST : SRC : TAKE : 3/6
ROUTER : =1 : =1 : =1 : >EXEC :
```

- (4) For example, to change the pair to DEST1 and SRC2, turn **F3** to select 2.
- (5) Press **F3** to save the pair in the router crosspoint preset. After the preset has been changed in the router, 2 is displayed under **SRC**.

```
EXT I/F : LEVEL : DEST : SRC : TAKE : 3/6
ROUTER : =1 : =1 : =2 : >EXEC :
```

- (6) Repeat steps (2) and (5) to set all destination / source pairs to be saved.

Executing Multiple Switches Simultaneously

- (1) In PAGE 3, turn **F4** to select EXEC.
- (2) Press **F4** to execute multiple switches.

```
EXT I/F : LEVEL : DEST : SRC : TAKE : 3/6
ROUTER : =1 : =1 : =2 : >EXEC :
```

Displaying Preset Crosspoints

- (1) Go to PAGE 4.
- (2) Turn **F1** to select a level.

```
EXT I/F : LEVEL : XPT : PRESET : : 4/6
ROUTER : =1 : > : > : : :
```

- (3) Press **F3**. The preset crosspoints are displayed. To move among menu pages, use the page up and down buttons.

```
ROUTER : 1-1 2-2 3-3 : : 1/XX
PRESET : 4-4 5-5 6-6 : >BACK :
       7-7 8-8 9-9
       10-10 11-11 12-12
       | | |
```

◆ Clearing Preset Crosspoints

- (1) In PAGE 3, turn **F4** to select CANCEL.
- (2) Press **F4** to clear the settings.

```
EXT I/F : LEVEL : DEST : SRC : TAKE : 3/6
ROUTER : =1 : =1 : =2 : >CANCEL:
```

20-3-9. Router Link

The Router Link function allows you to switch a crosspoint on a router by pressing a switcher bus button when inputting video from the router.

The following example will help to explain how to set up and use this function.

In the connection example below, the DST4 video is input to the switcher INPUT1. The system will be set up so that if the switcher bus button 1, 2 or 3 is pressed, SRC7, SRC8 and SRC9 video are respectively sent to the switcher.

If Router Link is enabled, pressing a linked bus button sends a signal switch command to a router and the switcher receives the specified video from a router even if a different video is assigned to the associated destination channel on the router.

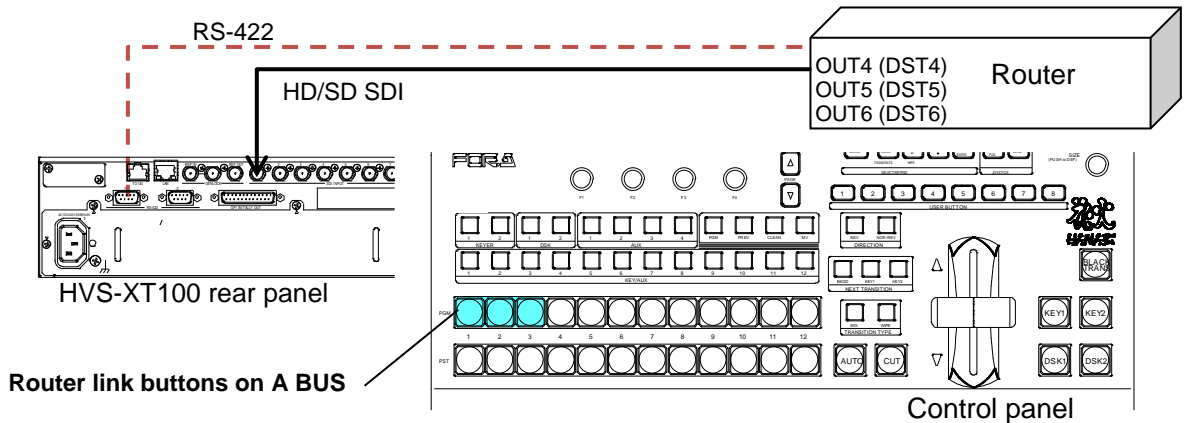

- * Router Link function can be applied to the M/E A bus and B bus. (See section 7-2. "Button Switching Mode in the M/E Bus.")

◆ Router Link Settings

(1) Go to [SETUP-EXT I/F-RTR LINK] menu PAGE 1.

Turn **ENABLE** to **ON**. Set up RTR XPT (router crosspoint) and SRC (source) pairs as shown below.

EXT I/F	: ENABLE	: RTR XPT	: RTR SRC	:	1/2
RTR LINK	: =ON	: =RX01	: =7	:	

EXT I/F	: ENABLE	: RTR XPT	: RTR SRC	:	1/2
RTR LINK	: =ON	: =RX02	: =8	:	

EXT I/F	: ENABLE	: RTR XPT	: RTR SRC	:	1/2
RTR LINK	: =ON	: =RX03	: =9	:	

(2) Open the [SETUP-INPUT-ASSIGN] (1/3) menu.

Assign crosspoints, RX01, RX02 and RX03, to bus buttons, 1, 2 and 3, as shown below.

INPUT	: BUTTON	: SIGNAL NAME	: INHIBIT	:	1/3
OU ASGN	: =01	: =RX01	: =RX01	: =OFF	:

INPUT	: BUTTON	: SIGNAL NAME	: INHIBIT	:	1/3
OU ASGN	: =02	: =RX02	: =RX02	: =OFF	:

INPUT	: BUTTON	: SIGNAL NAME	: INHIBIT	:	1/3
OU ASGN	: =03	: =RX03	: =RX03	: =OFF	:

(3) Go to [SETUP-EXT I/F-RTR LINK] menu PAGE 2.

Select **A BUS** under **BUS SELECT**. Set the swither input and the router destination channel as shown below.

EXT I/F :BUS SEL: INPUT :RTR DST:BUS EN : 2/2
RTR LINK: =A BUS: =IN01 : =4 : =OFF :

◆ **Router Link Operation**

Pressing Bus Button 1 on the swither displays the SRC7 image on the M/E output.

Pressing Bus Button 2 on the swither displays the SRC8 image on the M/E output.

Pressing Bus Button 3 on the swither displays the SRC9 image on the M/E output.

◆ **Available Bus for Router Link (Selectable bus under BUS SEL)**

A BUS, B BUS, AUX1-8

K1INS, K1SRC, K2INS, K2SRC, D1INS, D1SRC, D2INS, D2SRC, CKBUS, EFF1, EFF2

◆ **Router Crosspoints**

The maximum number of available router crosspoints and source/destination pairs are 64 and 256 respectively.

Aside from bus buttons, router crosspoints can be assigned to the followings.

- PGM/PST bus buttons on HVS-30RU units (See section 20-7. "Remote Panel.")
- Buttons on HVS-AUX16A/32A/64A units (See section 20-6. "AUX Bus Control Box.")
- GPI IN functions (See section 20-1. "GPI IN/OUT and Tally Outputs.")

◆ **Saving Router Link Settings to Events**

Router Link settings that are assigned to each bus can be saved to events.

When loading an event in which Router Link settings are stored, crosspoints on the router are changed after swither settings are complete.

20-4. Editor Control (HVS-XT100ED)

The switcher can be controlled from an editor through an RS-422 interface.

The HVS-XT100ED software option is required for editor control.
Use an RS-422 cross-over cable for the editor connection.

20-4-1. RS-422 Port Settings

- (1) Open the [SETUP - SYSTEM - RS-422] menu.
- (2) To connect the editor to the RS-422(2) port, set the menu as shown below. The BAUD rate and PARITY are automatically set.

```
SYSTEM : SELECT : FUNC      : BAUDRAT : PARITY : 1/1
RS-422 : =PORT2 : =EDIT  : =34800 : =ODD   :
```

In some cases, setting BAUDRATE to 38400 may cause the system to malfunction. In such cases, re-establish the connection with either of the options below.

- (a) Set **Stop Bit** to **1.5** or **2** in the target device.
- (b) Set **Baudrate** to **39300** in the switcher.

- (3) After settings are complete, reboot the switcher.

▶ See section 19-1. "Rebooting System."

20-4-2. Editor Control Settings

- (1) Open the [SETUP - EXT I/F - EDITOR] menu.
- (2) Select a protocol under **TYPE** between **DVS**(SONY DVS/BVS series compatible) and **GVG-K/Z**.

```
FUNCTION: TYPE      : ENABLE : SELECT : WIPE  : 1/2
EDITOR   : =DVS          : =OFF  : =ME    : =NORML:
```

If **DVS** is used:

If DVS is used, the bus to be controlled from the editor must be specified. Refer to the table below to set the bus under **SELECT**. If **PREV**, **PREV ON** or **ALL** is set, AUX1 will be the edit preview bus and its crosspoint number is 46. Set your editor accordingly.

Setting	Description
ME	Controls the M/E bus when ENABLE is ON.
PREV	Controls the preview bus when ENABLE is ON.
ALL	Controls both M/E bus and preview bus when ENABLE is ON.
ME ON	Always controls the M/E bus regardless of the ENABLE setting. Controls both M/E bus and preview bus when ENABLE is ON.
PREV ON	Always controls the preview bus regardless of the ENABLE setting. Controls both M/E bus and preview bus when ENABLE is ON.

If **G-K/Z (GVG protocol)** is used:

Select a pattern control mode between the two below at **WIPE**.

Setting	Description
NORMAL	Same wipe pattern numbers (0-99) as in the switcher are used in the editor. (default setting)
LIST	Ten wipe patterns saved to Direct Pattern memory are used in the editor as Direct Pattern No. 90-99. (GVG-Protocol only)

(3) Press the page down button to go to PAGE2.

FUNCTION:XPT CTL:WIP CTL:KEY CTL:	: 2/2
EDITOR : =INPUT: =ON : =ON :	:

(4) Select a crosspoint control mode between two below at **XPT CTL**.

INPUT	Specify a signal using the input number from the editor. (Default setting)
BUTTON	Specify a signal using the button number from the editor.

BUTTON
Button number
1-12

INPUT	
Input number	Source signal
0	BLACK
1-14	IN01-IN14
29-30	STILL1-2
31-32	STILK1-2
37	COLOR BAR
38, 39	MATTE1-2
40	CK FILL
41	CK KEY
42-43	EFF1-2

(5) Set to enable/disable the wipe pattern control under **WIP CTL**.

(6) Set to enable/disable the KEY control under **KEY CTL**. (Be careful that in such case KEY will not turn automatically OFF when ALL STOP is received in the switcher.)

20-4-3. Editor ON/OFF

To enable the editor control, set **ENABLE** to **ON** in [SETUP - EXT I/F - EDITOR] menu PAGE1.

FUNCTION: TYPE	: ENABLE	: SELECT	: WIPE	: 1/2
EDITOR : =DVS	: = ON	: =ME	: =NORML:	

The Editor Control On/Off function can be assigned to a USER button.

► See section 14. "USER Buttons."

20-5. AUX Bus Control Box (HVS-AUX8/16/32)

HVS-AUX8/16/32 units allow you to remotely change an AUX bus signal. An AUX box can control a single AUX output. HVS-AUX8 units can select up to 8 signals (14 if using SHIFT). HVS-AUX16/32 units can select combined signals (PGM, PREV, and CLEAN) as well as input signals. Up to 5 AUX units can be connected to the switcher.

HVS-XT100ARC, an optional Arcnet I/F Card, is required for AUX box connections.

20-5-1. Connecting AUX Boxes

AUX boxes are connected to the switcher through a specialized **ARCNET** network. When installing an optional Arcnet card (HVS-XT100ARC), two BNC connectors are added to the switcher rear panel. Connect AUX boxes to the switcher in a cascade as shown below and terminate both ends of the network chain with 75-ohm terminators.

◆ ARCNET ID Numbers

Arcnet ID numbers from **1 to 255** are used to uniquely identify a network terminal. The Arcnet ID number for **HVS-XT100/110** is set to **250** as factory default.

Note: Do **not** duplicate an Arcnet ID number.

▶ See the "HVS-AUX8/16/32 Operation Manual" for more details.

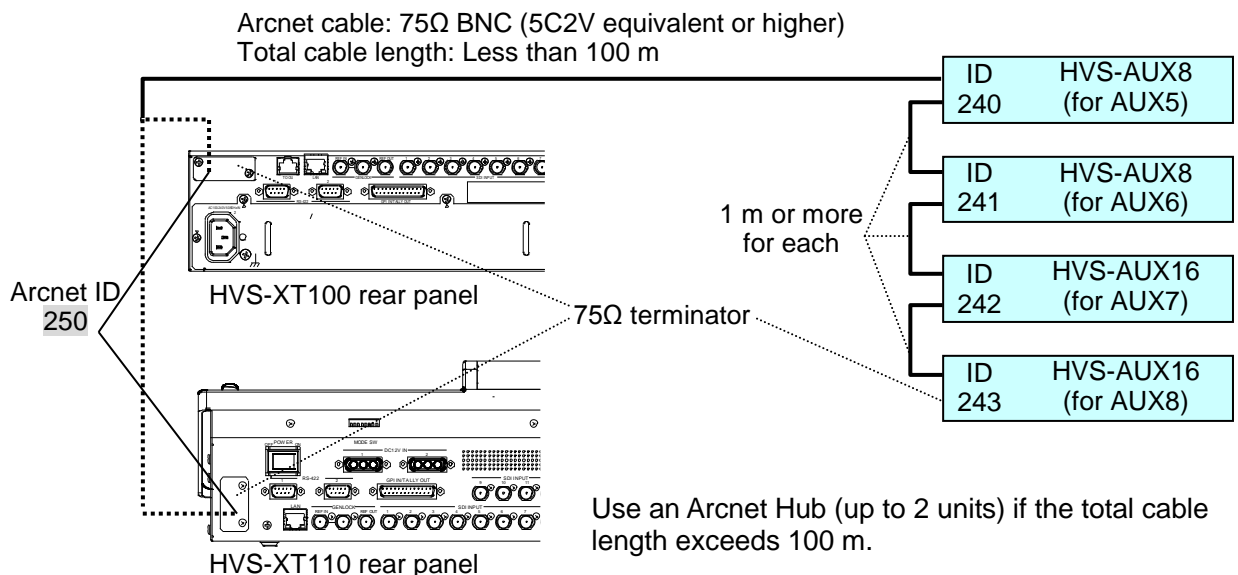

◆ To Change the Switcher ARCNET ID Number

The Arcnet ID number for **HVS-XT100/110** is set to **250** as factory default and does not normally need to be changed. Change the ID number in the [SETUP - SYSTEM -ARCNET] menu only when necessary.

SYSTEM	: MU ID :		: 1/1
ARCNET	: = 250 :		:

To apply the change, turn the switcher power Off, then On.

20-6. AUX Bus Control Box (HVS-AUX16A/32A/64A)

HVS-AUX16A/32A/64A units allow users to remotely change AUX output signals or recall events of the switcher. A single AUX Box can manage all AUX outputs. Up to 16 (32 with SHIFT) actions can be assigned to buttons on HVS-AUX16A, 32 (64 with SHIFT) on HVS-AUX32A and 64 on HVS-AUX64A. Up to 5 AUX units can be connected to the switcher.

A LAN cable is required for the AUX box connection.

20-6-1. Connecting AUX Boxes

AUX boxes should be connected to the switcher through LAN cables. To connect an AUX box directly to the switcher, use a **cross-over** cable. To connect an AUX box via a network hub, use a **straight-through** cable.

◆ AUX ID Number

AUX ID numbers from 1 to 255 are used to uniquely identify an AUX box. To connect to HVS-XT100/110 units, use **ID1 to ID5**. (Default setting: ID1) The ID numbers should not be duplicated when connecting to a switcher.

▶ See the "HVS-AUX16A/32A/64A Operation Manual" for more details.

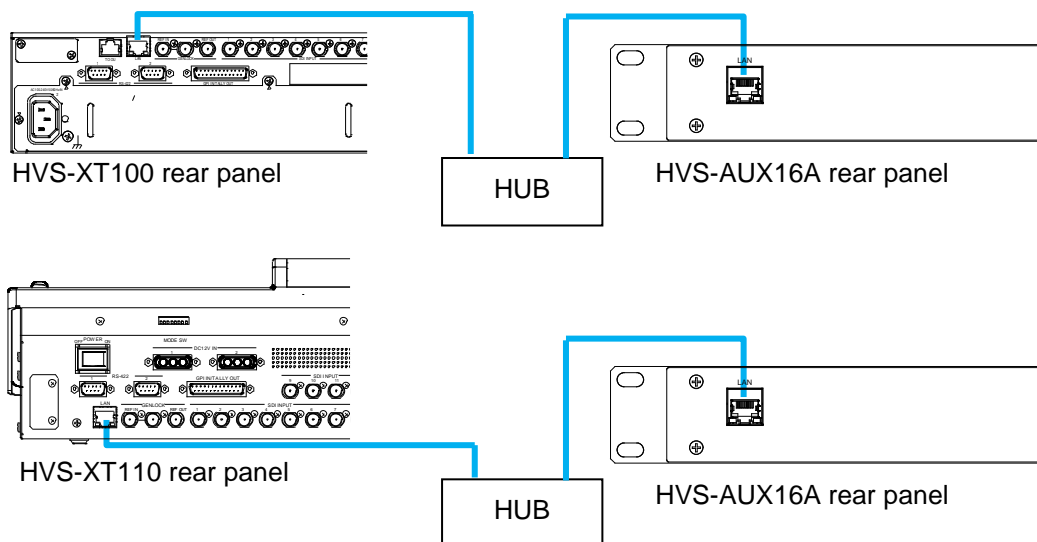

◆ Checking AUX Box MAC Addresses

AUX Box MAC addresses can be checked from the switcher. The following example shows how to check the connected HVS-AUX16A MAC address.

- (1) Open [SETUP - EXT I/F - AUX UNIT] menu PAGE 1.
- (2) Select **UNIT1**[xxBTN] under **SELECT**.
- (3) Open [SETUP - EXT I/F - AUX UNIT] menu PAGE 4.
The unit's MAC address is displayed as shown below.

AUX UNIT:	MAC ADDRESS	:	4/4
MAC ADDR:	00-00-00-00-00-00	:	

20-6-2. Assigning Actions to AUX Box Buttons

Assigning actions to AUX Box buttons should be performed in the switcher menu.

Ex.) To "Output the PGM signal from the AUX3 bus on UNIT 1:

There are two ways to perform this action.

- Assign "AUX3 XPT M/E1 PGM" to a button and press the button.
- Assign "AUX3 bus" to a button and "PGM signal" to another button, then press these buttons.

◆ If Using Only a Single AUX Box Button:

- (1) Open [SETUP - EXT I/F - AUX UNIT] menu PAGE 1.
- (2) Select **UNIT1** under **SELECT**. Note that the total number of buttons are displayed in parentheses.

AUX UNIT:	SELECT	:	AUX SEL:	:	1/4
SELECT	:	=UNIT1[XXBTN]	:	=AUX1	:

AUX ID Number

- (3) Open [SETUP - EXT I/F - AUX UNIT] menu PAGE 3.

- (4) Set the menu as shown below.

AUX UNIT:	SELECT:	TYPE	:	FUNC(F3)	:	3/4
PANEL	:	=1	:	=AUX3	:	=AUX3 XPT M/E1 PGM

Button number Action type (See the table in the next page.) Action (See the table in the next page.)

- (5) Press **Button 1** on UNIT 1. The AUX 3 output signal is changed to PGM.

◆ If Using Two AUX Box Buttons:

- (1) Select UNIT 1 on PAGE 1 in the same way as above.
- (2) Set as shown below for **Button 1** in [SETUP - EXT I/F - AUX UNIT] menu PAGE 3.

AUX UNIT:	SELECT:	TYPE	:	FUNC(F3)	:	3/4
PANEL	:	=1	:	=AUX	:	=AUX3 XPT SELECT

- (3) Set the menu as shown below for **Button 2**.

AUX UNIT:	SELECT:	TYPE	:	FUNC(F3)	:	3/4
PANEL	:	=2	:	=AUX	:	=AUX XPT M/E1 PGM

- (4) Press **Button 1** then **Button 2** on UNIT 1. The AUX 3 output signal is changed to PGM.

◆ **TYPE and FUNC Settings**

AUX Box buttons light as shown below to indicate the status.

When an action is assigned to a button: **Dim-lit**

When an action is being performed: **Lit green**

TYPE Setting	FUNC (action) Setting	Description
NONE	(NOT ASSIGN)	
AUX	AUX1 XPT SELECT AUX8 XPT SELECT	Selects an AUX bus.
	AUX XPT BLACK AUX XPT IN1-14 AUX XPT STILL1-2 AUX XPT STILL1-2 KEY AUX XPT COLORBAR AUX XPT MATTE1-2 AUX XPT CK FILL AUX XPT CK KEY AUX XPT SUB EFFECT1-2 AUX XPT M/E1 PGM AUX XPT M/E1 PREV AUX XPT M/E1 CLEAN AUX XPT M/E1 KEYOUT AUX XPT MV	Selects a signal to be output an AUX bus. Note that an AUX bus should be selected using buttons assigned to "AUX1 XPT SELECT" to "AUX8 XPT SELECT" above before pressing a signal selection button. If an AUX bus is not selected when pressing a signal selection button, the selected signal is applied to the AUX bus set under AUX SEL in [SETUP - EXT I/F - AUX UNIT] menu PAGE 1 on the HVS-XT100/110.
	AUX1 TRANS ENABLE AUX8 TRANS ENABLE	Sets AUX crossfade switches to On/Off.
AUX1	AUX1 XPT BLACK AUX1 XPT MV AUX1 TRANS ENABLE	Selects a signal to be output from an AUX bus.
AUX8	AUX8 XPT BLACK AUX8 XPT MV AUX8 TRANS ENABLE	Selects a signal to be output from an AUX bus.
EVENT	EVENT NO.00-99 RECALL	Loads an event.
MACRO	MACRO NO.00-29 RECALL	Recalls a macro.
R DST	ROUTER DST NO.001-256	Selects a destination on the router.
R SRC	ROUTER SRC NO.001-256	Selects a source on the router.

20-6-3. Assigning the SHIFT or TAKE Function

HVS-AUX16A/32A units can use additional 16/32 buttons by using the SHIFT function. In addition, HVS-AUX16A/32A/64A units can use the TAKE (confirmation) function.

Note that the SHIFT and TAKE functions cannot be used simultaneously. The TAKE function is always enabled by setting TAKE to ON in the menu regardless of SHIFT state.

◆ **Using the SHIFT function**

- (1) Open [SETUP - EXT I/F - AUX UNIT] menu PAGE 2.
- (2) Select **TGL** (Toggle) or **NOR** (Normal) under **SHIFT**.
- (3) Set **TAKE** to **OFF**.

AUX UNIT: BRIGHTNESS : SHIFT : TAKE : 2/4
 SELECT : H=8 L=1 : =**TGL** : =**OFF** :

With these settings, HVS-AUX16A/32A units can use additional 16/32 buttons using the **SHIFT/TAKE** button. Refer to the table in the next page for details on how to use this button.

Parameter	Default	Setting	Description
SHIFT	OFF	OFF	Additional buttons cannot be used.
		TGL	Pressing the SHIFT/TAKE button enables SHIFT and pressing the button again disables SHIFT.
		NOR	SHIFT is enabled while the SHIFT/TAKE button is pressed.

◆ **Using the TAKE (Confirmation) Function**

(1) Open [SETUP - EXT I/F - AUX UNIT] menu PAGE 2.

(2) Set TAKE to ON.

Parameter	Default	Setting	Description
TAKE	OFF	OFF	An action is immediately executed (by pressing the action button) without pressing TAKE.
		ON	An action is executed by pressing TAKE after pressing the action button. Press TAKE within 5 seconds after pressing an action button. Otherwise, the operation will be canceled.

20-6-4. Adjusting Light Levels for AUX Box Buttons

Light levels for AUX Box buttons can be adjusted in [SETUP - EXT I/F - AUX UNIT] menu PAGE 2 as shown below.

AUX UNIT: BRIGHTNESS : SHIFT : TAKE : 2/4
SELECT : H= 8 L= 1 : =OFF : =OFF :

Parameter	Default	Setting	Description	
BRIGHTNESS	H	8	5 - 8	Adjusts the normal lighting level.
	L	1	0 - 4	Adjusts the dim lighting level.

20-7. Remote Panel (HVS-30RU)

HVS-30RU, a HANABI series remote unit, can remotely control HVS-XT100 series switcher.

20-7-1. RS-422 Port Settings (HVS-30RU)

The switcher can connect to and be controlled by an HVS-30RU via the RS-422 (1) or (2) port. Connect the HVS-30RU to the switcher with the supplied RS-422 cable (10 m)

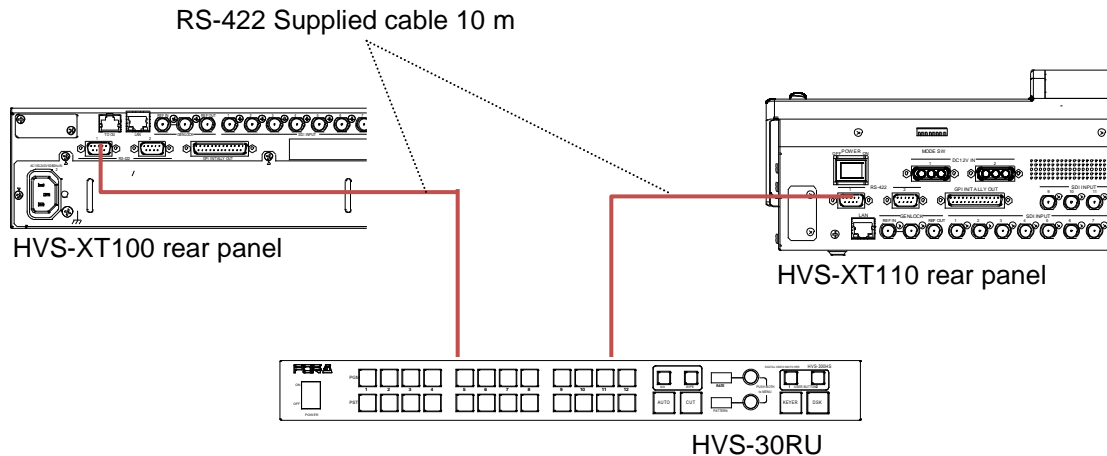

Perform the RS-422 port settings following the procedure below.

- (1) Open the [SETUP - SYSTEM - RS-422] menu.
- (2) To use RS-422(1), set the menu as shown below. BAUD rate and PARITY will be automatically set.

SYSTEM	:	SELECT:	FUNC	:	BAUD	:	PARITY	:	1/1
RS-422	:	=PORT1:	=30RU	:	=153K	:	=NONE	:	

- (3) After settings are complete, reboot the switcher.

► See section 19-1. "Rebooting System."

20-7-2. Assigning Sources to PGM/PST Bus Buttons

The PGM/PST bus buttons on the HVS-30RU can be assigned to signals on the switcher using the [SYSTEM - INPUT - ASSIGN] menu.

To Use Same Settings between the Control Panel and Remote Panel:

- (1) Open the [SETUP - INPUT - ASSIGN] menu. Go to PAGE 3.
- (2) Turn **F1** to select RU.
- (3) Set **LINK** to **ON**, then press **F3**.

INPUT	:	SELECT:	SHIFT	:	LINK	:		:	3/3
ASSIGN	:	=RU	:	=NORML:	=ON	:		:	

To Use Different Settings between the Control Panel and Remote Panel:

- (1) Turn **F1** to select **RU** in **PAGE3**.
- (2) Set **LINK** to **OFF**, then press **F3**.

INPUT	:	SELECT:	SHIFT	:	LINK	:	:	3/3
ASSIGN	:	= RU	:	=NORML:	= OFF	:	:	:

- (3) Go to **PAGE2**.
- (4) Set the button and input assignments. For example, "to assign **Button 1** to **Input 4 (CAM4)**," set the menu as shown below.

INPUT	:	BUTTON	:	SIGNAL NAME	:	INHIBIT:	2/3
RU ASGN	:	= 01	:	= IN04	:	= CAM4	: =OFF :

Set other buttons on the HVS-30RU in the same way.
 If **INHIBIT** is set to **ON** for a button, the selected button is inactive.

20-7-3. Setting USER Buttons

The free functional (USER) buttons on the HVS-30RU can be set on the switcher using the menu as shown below.

USER Button Default Assignments

Button	Default setting
USER button 1	AUX XPT SELECT
USER button 2	KEY XPT SELECT

Assigning Functions to USER Buttons

- (1) Display the [SETUP - PANEL - USER BTN] menu.
- (2) Set the user button and function assignments. For example, "to assign **User Button 1** to **DSK1 SCALER**," set the menu as shown below.

PANEL	:	SELECT	:	TYPE	:	FUNC(F3)	:	1/2
USER BTN:	= RU-1	:	= USTRS :	= DSK1 SCALER	:	:	:	:

- ▶ See section 14 "USER Buttons" for details on USER buttons.
- ▶ See the "HVS-30RU/30FP Operatin Manual" for details on available functions.

21. SmartDirect Control (Option)

The switcher can connect to the FOR-A all-in-one production system, SmartDirect, and execute Direct Buttons' actions.
Consult your FOR-A reseller for more details on SmartDirect.

An HVS-100VR software option is required for SmartDirect connection.

21-1. Connecting to SmartDirect via Ethernet

◆ Connection Example

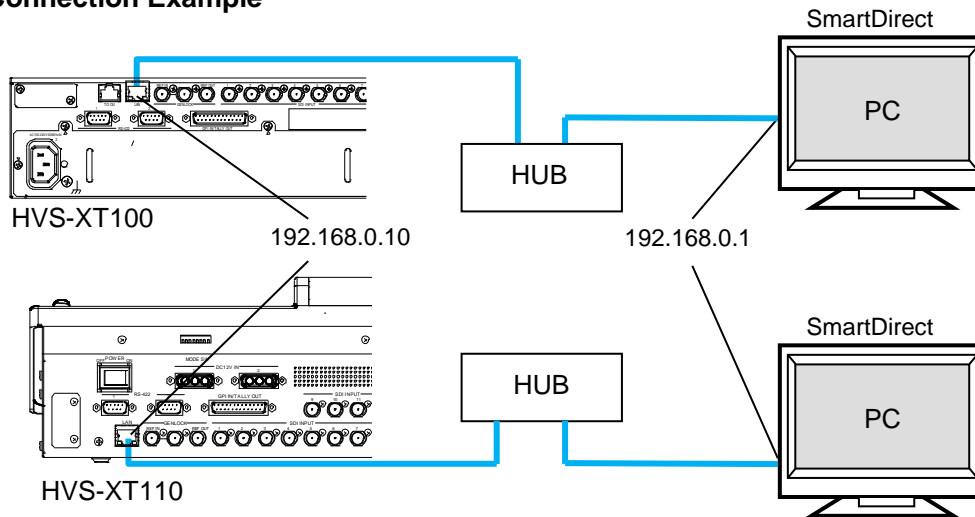

Check and set the SmartDirect IP address.

- (1) Open the [SETUP - FUNCTION - SMRT DIR] menu.
- (2) Go to PAGE 2.
- (3) The procedure example for changing the fourth octet to 1 is as follows:

- (a) Press **F2** four times.
- (b) Turn **F2** to change 001.
- (c) Press **F2**.

```
FUNCTION:           :IP ADDRESS           : 2/2
SMRT DIR:           :=192.168.000.001     :
```

- (4) Go to PAGE 1.
- (5) Set **ENABLE** to **ON**.

Once the switcher is connected to SmartDirect, Direct Button names can be displayed as shown below.

If a Direct Button name is changed while displaying PAGE1, reopen PAGE 1.

```
FUNCTION:ENABLE    : DIRECT BUTTON       : 1/2
SMRT DIR: =ON      : >DirectButton1     :
```

Maximum of 230 Direct Button names with **up to 16 alphanumeric letters** per name can be displayed in the menu. Direct Button names must be unique.

21-2. Executing Direct Buttons

The following two methods are available for executing Direct Buttons.

21-2-1. Executing in the Menu

(1) Open the [SETUP - FUNCTION - SMRT DIR] menu.

FUNCTION:ENABLE	:	DIRECT BUTTON	:	1/2
SMRT DIR: =ON	:	>DirectButton1	:	P.00

(2) Turn **F2** to select a Direct Button name.

(3) Press **F2**. The Direct Button can be performed on the SmartDirect.

21-2-2. Executing Using Macros

Direct Buttons of SmartDirect can be registered to switcher's macros and then executed using them.

◆ Registering Direct Buttons to Macros

The following example procedure shows how to register **DirectButton1** to **Macro 01**.

(1) Press **MACRO**.

(2) Press **STORE** on the Keypad to start recording. The following menu will appear.

MACRO	:	STEP->000	:	ACTION	:	1/1
STORE	:	TIME->00000	:	>DirectButton1	:	P.00

(3) Turn **F3** to select **Direct Button1**.

(4) Press **F3**.

(5) Press **STORE** to stop recording.

(6) Press **1** on the Keypad.

* Direct Button names are not updated if you change them while recording the macro.

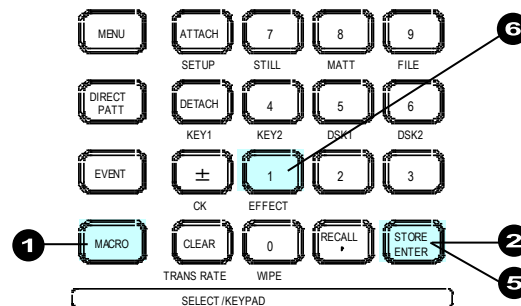

◆ Executing Macro01

(1) Press **MACRO**.

(2) Press **1**.

(3) Press **RECALL**.

► See section 16. "Macros" for more details on macros.

Macros can be edited in the Web-based control GUI (see section 23-15 "MACRO").

22. 3G-SDI Signals (HVS-XT100EXP3G)

Installing an HVS-XT100EXP3G option allows 3G-SDI

The following formats are available:

1080/59.94p (Level A) 1080/50p (Level A)

The following restrictions are applied when using 3G-SDI signals:

Upresizing unavailable for the standard and optional inputs
DVE available only for 2 channels
Optional analog input / output unavailable
Simultaneous outputs unavailable for HVS-XT100DO cards.

22-1. Selecting 3G-SDI Format

(1) Open the [SETUP - SYSTEM - FORMAT] menu.

(2) Turn **F1** to select 1080/59.94p or 1080/50p and press **F1**.

```
SYSTEM : FORMAT : ASPECT : SW TMNG : 1/1
FORMAT : =1080/59.94p : =16:9 : =ANY :
```

(3) Press **PAGE UP** to go back to the [SETUP-SYSTEM] menu. Select **REBOOT** and press **F1**.
Press **ENTER** in the SELECT/KEYPAD block to reboot the switcher.

22-2. 4K Mode

This mode allows the switcher to input and output 4K (Ultra HD) images using four 3G-SDI inputs and outputs (Square Division).

22-2-1. 4K Image Input / Output Settings

Available four input and output channels are:

4K inputs: IN01-04, IN05-08 and IN09-12

4K outputs: AUX1-4 and AUX5-8

(1) Open [SETUP - FUNCTION - 4K CTRL] menu PAGE 1.

(2) Turn **F1** to set **CONTROL** to **ON** to enable 4K mode.

```
FUNCTION: CONTROL: KEYS : DSK ASSIGN : 1/5
4K CTRL : =ON : =U-L : 1=B-R : 2=PVW :
```

(3) Go to PAGE 2. Select four inputs and outputs used for 4K images.

The following settings use **IN01-04**, **IN05-08** and AUX1-4 (**OUT1-4**) for 4K images.

```
FUNCTION: INPUT TYPE : OUTPUT TYPE : 2/5
4K CTRL : IN01-04 : =4K(UHD) : OUT1-4 : =4K(UHD) :
```

```
FUNCTION: INPUT TYPE : OUTPUT TYPE : 2/5
4K CTRL : IN05-08 : =4K(FHD) : OUT1-4 : =4K(UHD) :
```

To select the 4K input for IN01-04, press Bus Button **1** (IN01).

To select the 4K input for IN05-08, press Bus Button **5** (IN05).

To select the 4K output for OUT1-4 (AUX1-4), press **AUX1**.

HVS-X100 rear panel

Control panel

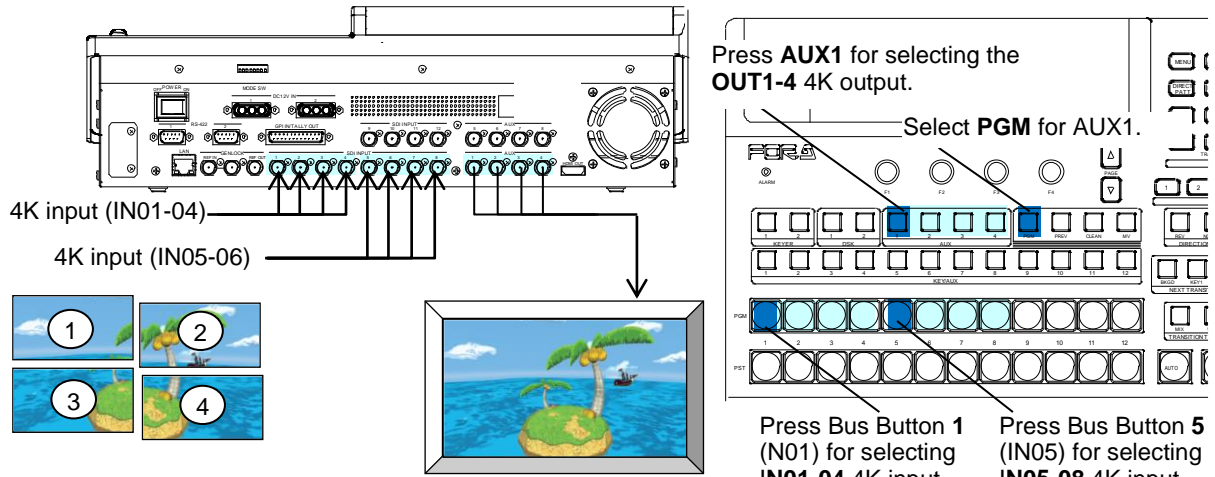

◆ **Notes on 4K mode (CONTROL set to ON)**

- Only **Mix** is available for transition type.
- The **HDMI** output signal is fixed to **MV**.
- Set **INPUT TYPE** to **2K(FHD)** for 2K (Full HD) images for key sources.
- Inputting a single 2K video (including internally generated signals such as stills and mattes) to 4K mode channels displays four images in a quad screen.

Ex.1) If IN05 is selected AUX1 (PGM) and set the menu as shown below:

```
FUNCTION: INPUT TYPE      : OUTPUT TYPE : 2/5
4K CTRL  : IN05-08 : =4K(FHD) : OUT1-4 : =4K(UHD) :
```

4K (UHD) video sources that are input in 4K mode and output in 4K mode are displayed as a single image in full-screen.

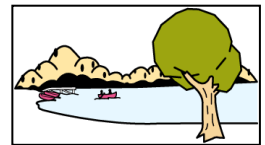

Ex.2) If IN05 is selected AUX1 (PGM) and set the menu as shown below:

```
FUNCTION: INPUT TYPE      : OUTPUT TYPE : 2/5
4K CTRL  : IN05-08 : =2K(FHD) : OUT1-4 : =4K(UHD) :
```

2K (FHD) video sources that are input in 2K mode and output in 4K mode are displayed as four images (IN05) in a quad screen.

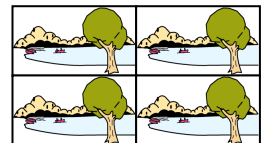

◆ **Disabling 2K (FHD) video input as background video**

Set **2K ASSIGN INHI** to **ENABLE** in PAGE 3.

This limitation is not applied to AUX outputs and keys.

```
FUNCTION: 2K ASSIGN INHI : EXT DSK CONTROL : 3/5
4K CTRL  : =ENABLE      : =KEY1 : =ON :
```

USER buttons can be used for disabling 2K (HD) video input in 4K mode.

► See section 14. "USER Buttons" for details on USER button operation

TYPE setting	Function setting	Description
OTHER	2K ASSIGN INHI EN	Disables single 2K(FHD) image input in 4K mode.

22-2-2. KEY/DSK Display

The following restrictions are applied to KEY and DSK on 4K images.

- KEY1 and 2 must be displayed on the same output bus (a quadrant in a quad screen)
- DSK1 and 2 cannot be displayed on the PGM or PVW video simultaneously.
- If **DSK2** is set to **PVW**, DSK1 and DSK2 are displayed in the same position on images and DSK2 is used as a PVW KEY.

KEY/DSK Example in 4K mode

When selecting **PGM** for **AUX1** and **IN01** for the **PGM** bus, to display KEYs and DSKs as shown at right set the menu as shown below,

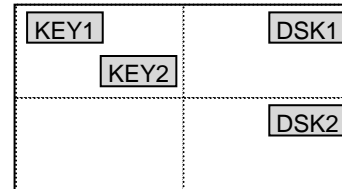

KEYER (KEY1, KEY2): **U-L** (Upper Left)
DSK1: **U-R** (Upper Right)
DSK2: **B-R** (Bottom Right)

```
FUNCTION:CONTROL:KEYER : DSK ASSIGN : 1/5
4K CTRL : =ON : =U-L :1=U-R :2=B-R :
```

22-2-3. 4K Key Link

The 4K Key Link function allows keys to be grouped as a master and slaves, and slave keys to be On or Off simultaneously by setting the master key to On or Off.

In such case, changing the master insert signal can change all slave insert signals. If the **KEY LINK** in the [SETUP - FUNCTION - M/E KEY] menu is set to **On**, key source signals are also changed.

◆ Creating the KEY Link Group

- (1) Open [SETUP-FUNCTION-4K CTRL] menu PAGE 4.
- (2) Turn **F2** to select a master key from KEY1, KEY2, DSK1 and DSK2 and press **F2**.

```
FUNCTION:LINK :MASTER : SLAVE : 4/5
KEY GRP : =ON : =DSK1 :1=DSK2 :2=OFF :
```

- (3) Turn **F3** to select a key for SLAVE1 and press **F3**.
Turn **F4** to select a key for SLAVE2 and press **F4**.

◆ Creating KEY XPT LINK Groups

- (1) Go to PAGE 5. Turn **F1** to select a group number from 1-10.
- (2) Turn **F2** to select a master insert signal and press **F2**.

```
FUNCTION:SELECT :MASTER : SLAVE : 5/5
LINK GRP: =1 : =IN01 :1=IN02 :2=OFF :
```

- (3) Turn **F3** to select an insert signal for SLAVE 1 and press **F3**.
Turn **F4** to select an insert signal for SLAVE 2 and press **F4**.

◆ Setting 4K KEY LINK to ON

- (1) Open [SETUP-FUNCTION-4K CTRL] menu PAGE 4.
- (2) Set **LINK** to ON.

22-2-4. Controlling External DSK Devices

DSKs on an external DSK Keyer can be controlled from the switcher using GPI pulse signals. To control a DSK key as shown below, set the following menu pages as shown below.

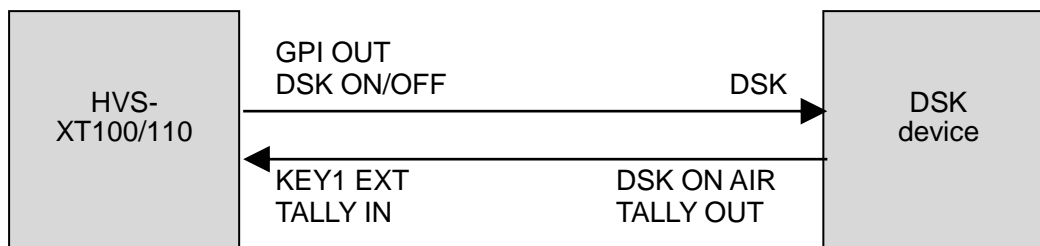

[SETUP-FUNCTION-4K CTRL] menu PAGE 3

FUNCTION:2K ASSIGN INHI :EXT DSK CONTROL: 3/5
4K CTRL : =ENABLE : =KEY1 : =ON :

[SETUP-GPI I/O] menu PAGE 2

GPI/TLY :SEL :PIN/TRG : FUNCTION : 2/3
GPI IN : =1 : =01Pos :=KEY1 EXT TALLY IN

[SETUP-GPI I/O]メニュー PAGE 3

GPI/TLY :P NO : STS : FUNCTION : 3/3
GPI OUT : =2 : =LOW :=KEY1 TRANS LINK

22-2-5. 4K GPI IN / TALLY OUT / AUX Action Buttons

The functions listed below are added in 4K mode.

- ▶ See section 20-1. GPI IN/OUT and Tally Outputs for details on GPI IN and TALLY OUT.
- ▶ See section 20-6-2 for details for assigning actions to AUX Box buttons.

GPI IN

FUNCTION setting	Description
KEY1 EXT TALLY IN	Replaces a KEYER ON switcher tally with a KEYER ON DSK tally.
KEY1 EXT TALLY IN	
DSK1 EXT TALLY IN	
DSK2 EXT TALLY IN	

TALLY OUT

FUNCTION setting	Description
KEY1-2 TRANS LINK	Outputs pulse while a key is superimposed in the connected DSK device.
DSK1-2 TRANS LINK	

Action assignable to AUX Box buttons

TYPE setting	FUNCTION setting	Description
AUX	AUX XPT RTR XPT01-64	Selects a router crosspoint for the controlled AUX bus.。

23. Web-based Control (Ver. 1.02.0-)

23-1. System Setup

◆ System Requirements

The HVS-XT100 Series web-based control feature needs a user-prepared computer, which must meet the following system requirements.

Operation System (tested and evaluated)	Windows XP or 7 iOS 6.1.3
Processor	Depends on the browser used.
Web browser	Safari 6.0 or higher, or Google Chrome recommended (Internet Explorer is not supported.)
RAM	Depends on the browser used.
Display	Resolution of 1024 × 768 pixels or higher 24-bit full-color
Network Port	Ethernet, at least 1 port 100BASE-TX/1000BASE-T
Network Cable	100BASE-TX: Category 5 or higher 1000BASE-T: Enhanced Category 5 or Category 6
Max. number of connection to the switcher	3

◆ Computer Network Settings

To connect to the switcher, set the IP address of your computer as follows:

IP Address	192.168.0.1 to 192.168.0.254 (except 192.168.0.10)
Subnet Mask	255.255.255.0

◆ Connecting to the Switcher

1. Use the LAN port on the switcher to connect to the PC directly or via a network hub.
▶ See section 12-4-1. "LAN Connection."
2. Launch your web browser. (Chrome or Safari recommended)
3. Enter "**http://192.168.0.10**" (default) in the address box and connect to the switcher.

IMPORTANT

If you have changed the switcher IP address, enter the changed address.

4. The HOME screen as shown on the next page will appear.
Verify that the connection indicator in the upper right corner is lit green.

IMPORTANT

Note that web browsers cannot automatically reconnect to the switcher after the switcher has rebooted (the connection indicator may be unlit). In such case, reconnect to the switcher or refresh the switcher control page on the web browser to re-establish the connection.

23-2. HOME

If you change the switcher menu settings on the web browser, they are immediately sent and applied to the switcher.

See the switcher manual main pages for details on switcher features.

The screenshot shows the 'HOME' page of the HVS-XT100 web interface. It features a status display at the top with a table of parameters, a grid of menu buttons, and an alarm indicator. Callouts provide details on these elements:

- Status display:** A table showing parameters for KGD, KEY1, KEY2, DSK1, and DSK2.
- Alarm indicator:** Located in the top right, it shows 'ALARM' and 'MU CONNECT' with green and red indicators. Legend: Lit green: Normal, Lit red: Abnormal.
- MU connection indicator:** Located in the top right, it shows 'MU CONNECT' with a green indicator. Legend: Lit green: Connection established, Unlit: Connection unestablished.
- Menu buttons:** A grid of buttons including EXT I/F, SETUP, STILL, MATTE, FILE, DIRECT PATT, KEY1, KEY2, DSK1, DSK2, EVENT, CHROMA KEY, SUB EFF, COPY SWAP, MACRO, TRANS, WIPE MODIFY, PATTERN, BUS TRANS, and MEMORY.

◆ Menu Buttons

Clicking a menu button in the HOME screen opens the relevant menu page.

EXT I/F p242	SETUP p233	STILL p224	MATTE p228	FILE p229
DIRECT PATT p218	KEY1 p220	KEY2 p220	DSK1 p220	DSK2 p220
EVENT p230	CHROMA KEY p222	SUB EFF p223		COPY SWAP p221
MACRO p231	TRANS p216	WIPE MODIFY p219	PATTERN p218	BUS TRANS P216
MEMORY				

Status Display

Status information (On-Air status, Transition Type, Transition Rate, Signal selection (XPT), Key type, DVE indication and an AUX bus if a DSK is displayed on it.), is displayed in the upper center of the HOME screen.

Alarm Indicator

The alarm indicator turns on red if a power or fan alarm, or loss of external synchronization occur in the switcher.

23-3. TRANS

Click **TRANS** in the HOME screen to display the TRANS menu page.

► See section 8. "Transitions."

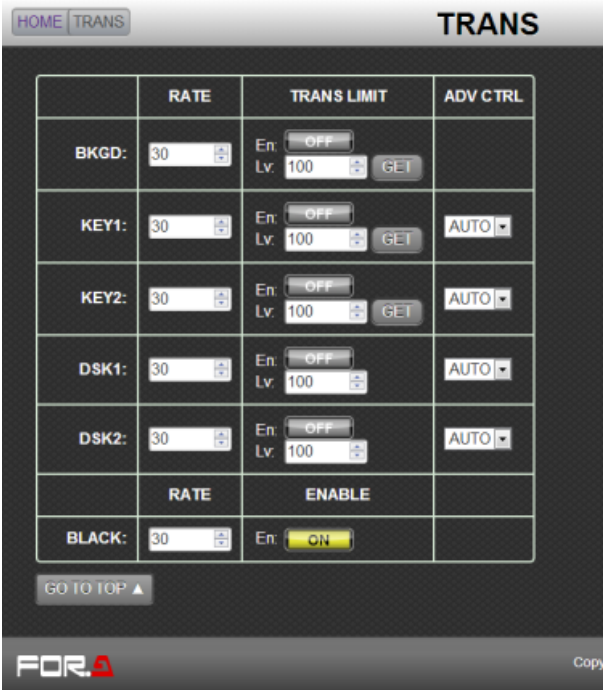

See the operation manual main pages for details on each function.

RATE

► See section 8-11-2. "Transition Rate."

TRANS LIMIT

► See section 8-11-3. "Transition Limit."

ADV CTRL

► See section 8-10-1. "Setting the KEY/DSK Transition Button Function."

BLACK

► See section 8-7 "Black Transitions."

23-4. BUS TRANS

Click **BUS TRANS** in the HOME screen to display the BUS TRANS menu page, in which nearly the same transition operations as those on the control panel can be performed.

► See section 8. "Transitions"

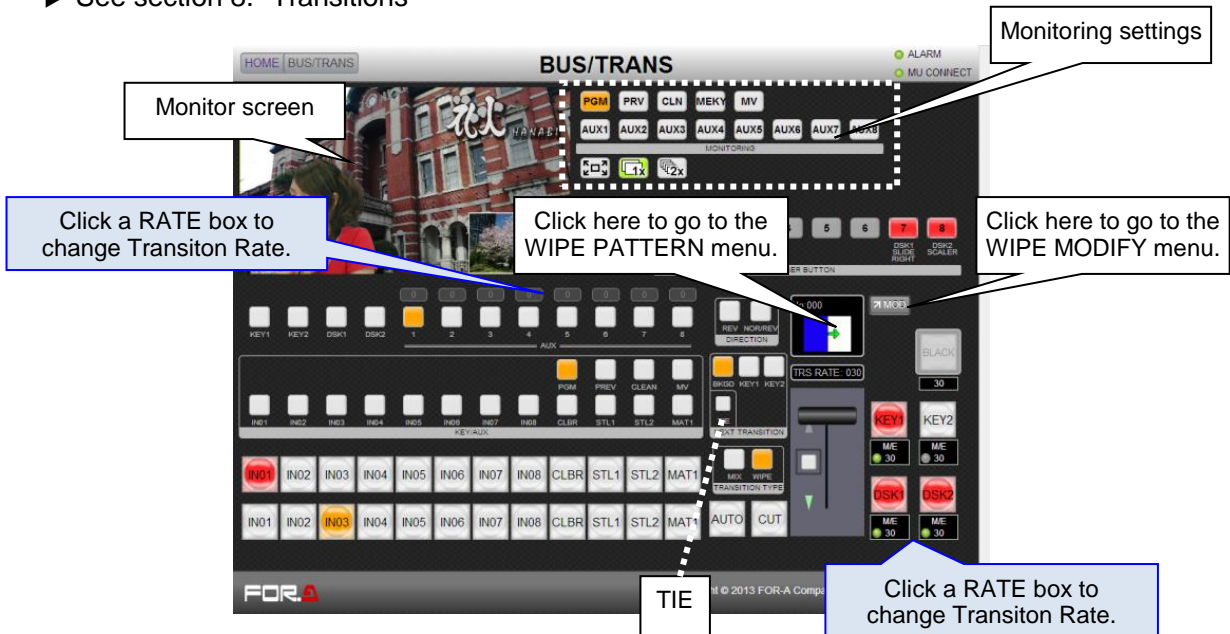

TIE Transition Setup

Click to turn **TIE** on. Successively click buses to be set them to the next transition.

► See section 8-6. "Simultaneous BKGD and Key Transitions"

Monitoring Settings

The upper buttons are used to select a video for monitoring.
The bottom buttons are used to select the monitoring mode.

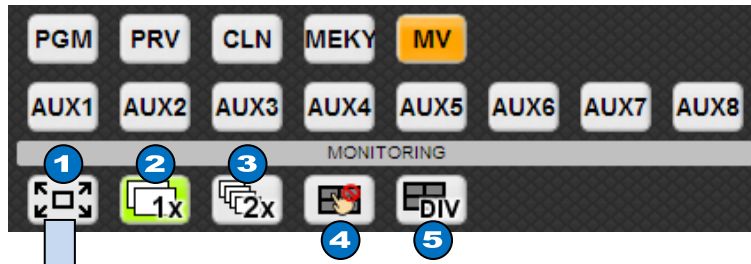

(1)	Enlarges and displays only the MONITORING section on the screen as shown below.
(2)	Shows a video in a higher resolution / lower rate.
(3)	Shows a video in a lower resolution / higher rate.



IMPORTANT

Note that the image displayed on the monitor may in some cases change temporarily when displaying the AUTO CK dialog using the GUI CHROMAKEY menu.

The buttons (4) and (5) appear while MV Video is displayed on the monitor screen.

(4)	Clicking the button to ON (lit green). Clicking one of the MV video images will change the PGM video to this image as shown below.	
-----	--	--

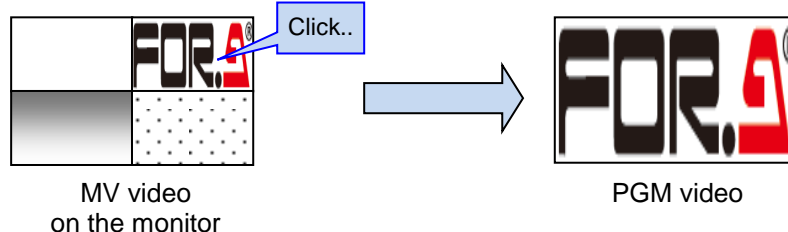

(5)	Clicking the button displays a dialog in which the number of MV windows can be changed. Note that the changed layout is applied not only to the MONITORING (BUS/TRANS) screen, but to the actual MV output.
-----	---

23-5. WIPE PATTERN

Click **PATTERN** in the HOME screen to display the WIPE PATTERN menu page.
This page allows you to easily assign transition patterns to background and key buses.
▶ See section 8-8-1. "Selecting a Pattern."

23-5-1. WIPE PATTERN - WIPE/DVE/Other

The **WIPE**, **DVE** and **Other** tabs allows you to assign patterns to buses.

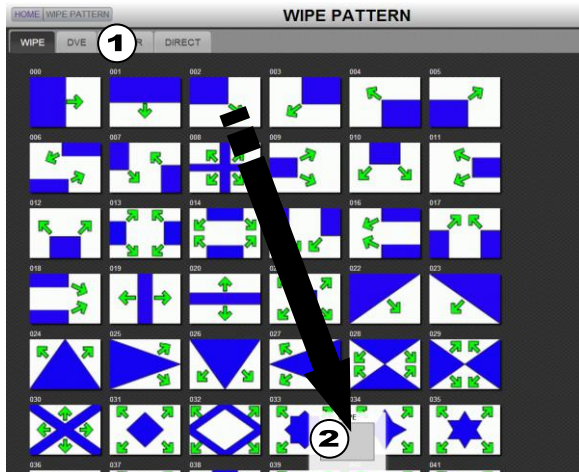

- (1) Click a tab to select the pattern type.
- (2) Drag a pattern and drop it onto the desired bus icon.

23-5-2. WIPE PATTERN - DIRECT

Clicking the **DIRECT** tab in the WIPE PATTERN menu page, or **DIRECT PATT** in the HOME screen displays the following screen, in which patterns can be saved to and deleted from the DIRECT pattern list, and be easily assigned to buses.

▶ See section 8-8-3. "Direct Pattern."

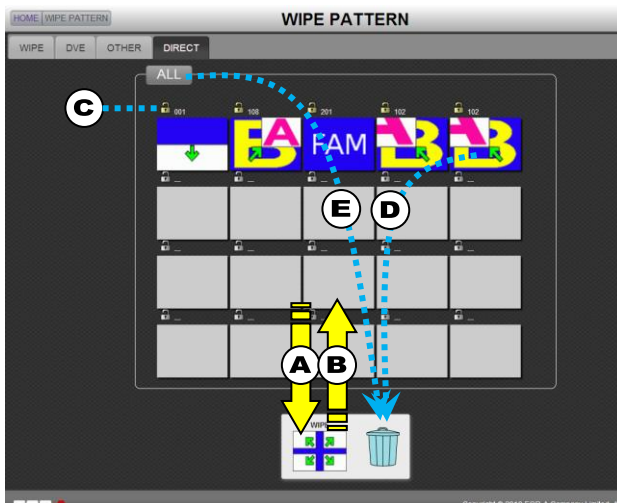

- (A) To select a WIPE pattern, drag & drop a pattern to the WIPE box in the bottom of the screen.
- (B) To add a pattern to the DIRECT pattern list, drag the currently selected pattern and drop it in the DIRECT pattern list.
- (C) To lock or unlock each pattern in the list, click the Lock icon.
- (D) To delete a pattern from the list, drag & drop the pattern to the Recycle Bin (Trash Box).
- (E) To delete all patterns from the list, drag & drop **ALL** to the Recycle Bin (Trash Box).

23-6. WIPE MODIFY

Click **WIPE MODIFY** in the HOME screen to display the WIPE MODIFY menu page.

► See section 8-9. "Modifying Patterns."

The screenshot shows a web browser window with the URL 192.168.0.10/wipe.html. The page title is "WIPE MODIFY". At the top, there are navigation buttons: HOME, WIPE MODIFY, BORDER, POS/ANGLE, MULTI, SUB EFF, CG WIPE, and INIT. The "BORDER" section is active and contains the following controls:

BORDER			
SIGNAL:	MATT	WIDTH:	0.0
SOFT:	0.0	BORDER COLOR:	S: 66.3 L: 5.4 H: 3.5
COL SELECT			

Below the BORDER section is a "GO TO TOP" button. The "POS/ANGLE" section contains the following controls:

POS/ANGLE			
POSITION:	X:	ANGLE:	0.0
	Y:		
ASPECT:			

Below the POS/ANGLE section is another "GO TO TOP" button.

Click a button to go to the desired menu block.

* The WIPE MODIFY menu pages vary depending on the selected pattern type.

23-7. KEY and DSK

Click **KEY1** or **KEY2** in the HOME screen to display each KEY menu page.
Click **DSK1** or **DSK2** to display each DSK menu page in the same way.

► See section 9. "KEY/DSK"

The screenshot shows the KEY1 menu interface with the following sections and settings:

- INS/SRC:** TYPE: BUS, INVERT: OFF, INSERT: BLACK, SOURCE: BLACK, GAIN: 1, CLIP: 0.2, TRANSPARENCY: 0, FAM: OFF, CLIP: H: 100, L: 0, En: OFF, MATT COLOR: S: 00.3, L: 5.4, H: 3.5, COL SELECT.
- EDGE:** TYPE: OFF, SOFT: 0, TRANSP: 0, WIDTH: 1, POSITION: X: 0, Y: 0, EDGE COLOR: S: 00.3, L: 5.4, H: 3.5, COL SELECT.
- MASK:** TYPE: OFF, BOXMASK: OFF, MASK(EXTIPRST): SRC: OFF, INV: OFF, BOXMASK POS: TOP: 0, BOTTOM: 0, LLFT: 0, RIGHT: 0, WIPE PATT: 0, LEVEL: 100, WIPE POS: X: 0, Y: 0, WIPE ANGLE: 0, ASPECT: 0, MULTI: X: 1, Y: 0, SOFT: 0.
- POS/SIZE:** POS/SIZE: X: 0, Y: 0, SIZE: 1000, 2D DVE: OFF, ASPECT: X: 1000, Y: 1000, FADE: 0, LOCAL ROTATION: X: 0, Y: 0, Z: 0, ROT SELECT, CENTER POSITION: X: 0, Y: 0, Z: 0, POS SELECT, CROP POSITION: T: 0, B: 0, L: 0, R: 0.
- BORDER:** INSIDE: X: 0, Y: 0, OUTSIDE: X: 0, Y: 0, SOFT INSIDE: X: 0, Y: 0, SOFT OUTSIDE: 0, BORDER COLOR: S: 0.0, L: 100.0, H: 0.0, COL SELECT.
- INIT:** INIT: OFF, EXLC, XPT HOLD: OFF.

Click a button to go to the desired menu block. See the operation manual main pages for details on each function.

INS/SRC

► See the following sections.

TYPE	9-1, 9-2 and 9-3
INSERT/SOURCE	
INVERT	9-6
GAIN/CLIP	9-4
CLIP (H L En)	

EDGE (KEY1 and KEY2 only)

► See section 9-7. "KEY EDGE"

MASK

► See section 9-6. "Mask and Invert"

To Enable 2D DVE effects, set 2D DVE to ON.

► See section 9-8-1. "How to Enable 2D DVEs."

POS/SIZE

► See the following sections.

POS/SIZE	9-8-2
ASPECT	9-8-3
FADE	9-8-4
LOCAL ROTATION	9-8-5
CENTER POSITION	
CROP POSITION	9-8-6

BORDER

► See section 9-8-7. "BORDERS."

INIT

Resets each KEY or DSK menu.

* When setting position parameters such as POS/SIZE, a dedicated dialog box will open to facilitate the position settings.

23-8. COPY SWAP (Web Control Only)

Click **COPY SWAP** in the HOME screen to display the COPY SWAP menu page, in which keyer settings can be easily copied from one to another (for example, KEY1 to KEY2 or DSK1) or swapped each other.

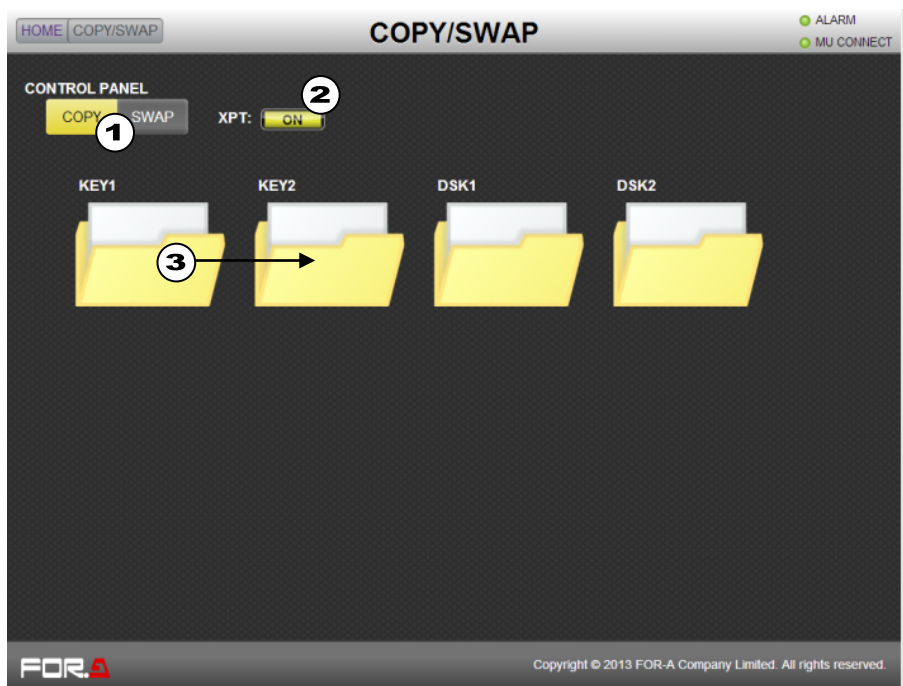

- (1) Click to select **COPY** or **SWAP** in the **CONTROL PANEL** field.
- (2) If copying or swapping signal selections, set **XPT** to **ON**.
- (3) Drag & drop from one bus folder to another. (KEY1 settings are copied to KEY2 in the example in the figure above.)

23-9. CHROMAKEY

Click **CHROMA KEY** in the HOME screen to display the CHROMAKEY menu page, in which a chroma key images can be created and adjusted.

▶ See section 10. "ChromaKey."

HOME | CHROMA KEY

CHROMA KEY

AUTO CK
ADJUST
MATTE
FOREGND
INIT

AUTO CK

XPT:	<input type="text" value="BLACK"/>		X:	<input type="text" value="0"/>
			Y:	<input type="text" value="0"/>
PGM OUT:	<input type="button" value="OFF"/>	POS/SELECT:	SEL:	<input type="button" value="OFF"/>
<input type="button" value="CK SELECT"/>				

ADJUST

BKGD COLOR:	SAT: <input type="text" value="0"/>	LUM: <input type="text" value="0"/>	HUE: <input type="text" value="0"/>	
DENSITY:	DENSITY: <input type="text" value="0"/>	WHITE: <input type="text" value="0"/>	RED: <input type="text" value="0"/>	
	SOLIDNESS: <input type="text" value="0"/>	BLACK: <input type="text" value="0"/>	GREEN: <input type="text" value="0"/>	BLUE: <input type="text" value="0"/>
SUPPRESSION:	SELECT: <input type="button" value="OFF"/>	WHITE: <input type="text" value="0"/>	RED: <input type="text" value="0"/>	
	SUPPRESS: <input type="text" value="0"/>	BLACK: <input type="text" value="0"/>	GREEN: <input type="text" value="0"/>	BLUE: <input type="text" value="0"/>
	SOLIDNESS: <input type="text" value="0"/>			

MATTE

EDGE SHRINK:	TOP: <input type="button" value="OFF"/>	CORING:	LUM: <input type="button" value="OFF"/>
	BOTTOM: <input type="button" value="OFF"/>		RED: <input type="button" value="OFF"/>
	LEFT: <input type="button" value="OFF"/>		GREEN: <input type="button" value="OFF"/>
	RIGHT: <input type="button" value="OFF"/>		BLUE: <input type="button" value="OFF"/>
POST FILTER:	H: <input type="button" value="OFF"/>	RECURSIVE FILTER:	<input type="button" value="OFF"/>
	V: <input type="button" value="OFF"/>		

FOREGND

EDGE REPLACE:	TOP: <input type="button" value="OFF"/>	RECURSIVE FILTER:	<input type="button" value="OFF"/>
	BOTTOM: <input type="button" value="OFF"/>	LIGHT&DARK EMPHASIS:	<input type="button" value="OFF"/>
	LEFT: <input type="button" value="OFF"/>		
	RIGHT: <input type="button" value="OFF"/>		

INIT

INIT: <input type="button" value="OFF"/>	<input type="button" value="EXEC"/>	XPT HOLD: <input type="button" value="OFF"/>
--	-------------------------------------	--

Copyright © 2013 FOR-A Compa

Click a button to go to the desired menu block. See the operation manual main pages for details on each function.

AUTO CK

▶ See section 10-1. "Creating a Chromakey."

ADJUST

▶ See section 10-2-1. "Adjusting Key Levels."

▶ See section 10-3-1. "[CHR KEY - ADJUST] Menu."

MATTE

▶ See section 10-2-3. "Adjusting Edges."

▶ See section 10-3-2. "[CHR KEY - MATT] Menu."

FOREGND

▶ See section 10-2-2. "Adjusting the Foreground Image (ChromaKey Color)."

▶ See section 10-3-3. "[CHR KEY - FORGND] Menu."

INIT

▶ See section 10-3-4. "Resetting Chromakey Settings"

222

23-10. SUB EFF

Click **SUB EFF** in the HOME screen to display the SUB EFF menu page, in which two SUB EFFECT channel images can be set.

► See section 11. "SUB EFFECT Channel."

HOME SUB EFF
SUB EFF

SUB EFF1
SUB EFF2
INIT

SUB EFF1			
XPT:	BLACK	MONO COLOR:	S: 0 H: 0 Ent: OFF
DEFOCUS:	H: 0 V: 0	PAINT:	Y: 0 C: 0
FREEZE:	OFF	STROBE:	OFF
NEGA:	OFF	MOSAIC:	OFF

GO TO TOP ▲

SUB EFF2			
XPT:	BLACK	MONO COLOR:	S: 0 H: 0 Ent: OFF
DEFOCUS:	H: 0 V: 0	PAINT:	Y: 0 C: 0
FREEZE:	OFF	STROBE:	OFF
NEGA:	OFF	MOSAIC:	OFF

GO TO TOP ▲

INIT		
INIT:	OFF	EXEC
XPTHOLD:	OFF	

GO TO TOP ▲

Copyright © 2013 FOR-A

Click a button to go to the desired menu block. See the operation manual main pages for details on each function.

SUB EFF1

SUB EFF2

► See the following sections.

XPT	11-1
MONO	11-2
DEFOCUS	11-3
PAINT	11-4
FREEZE, STROBE	11-5
NEGA, MOSAIC	

23-11. STILL

Click **STILL** in the HOME screen to display the STILL menu page. The STILL page allows you to save still images, save and play clips and backs up the still memory data.

► See section 12. "Still and Clip Store."

23-11-1. Still Store and Still Capture

To Capture Still Images

► See section 12-1-1. "Saving Stills."

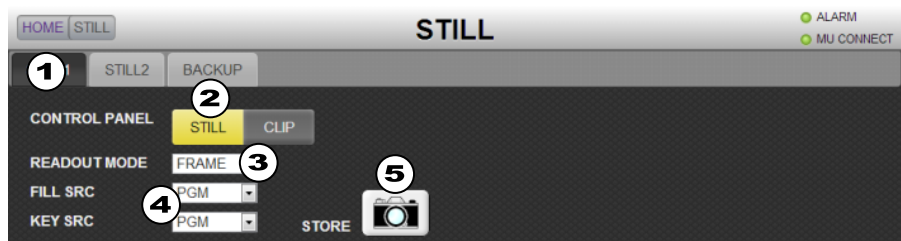

- (1) Click the **STILL1** or **STILL2** tab.
- (2) Select **STILL** (still image) under **CONTROL PANEL**.
- (3) Select **FRAME**, **ODD** or **EVEN** under **READOUT MODE**.
- (4) Specify signals under **FILL SRC** and **KEY SRC**.
- (5) Click **STORE** to save the captured still image.

To Record the AUX1 video to STILL1.

► See section 12-2-1. "Clip Recording"

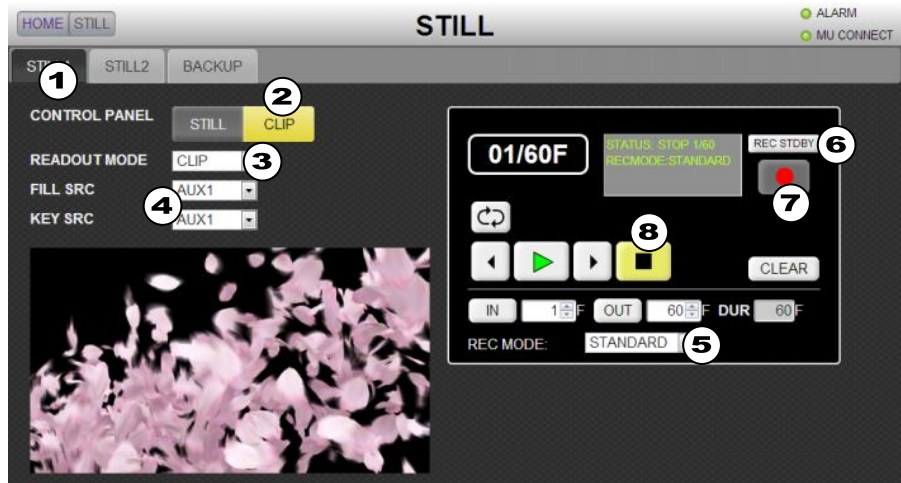

- (1) Click the **STILL1** tab.
- (2) Select **CLIP** (movie) under **CONTROL PANEL**.
- (3) Select **CLIP** under **READOUT MODE**.
- (4) Select **AUX1** under **FILL SRC** and **KEY SRC**.
- (5) Set **REC MODE** to **STANDARD** (default).
- (6) Click **REC STDBY**.
- (7) Click the **RECORD** button to start recording.
- (8) Click the **STOP** button to stop recording.

23-11-2. Play Clips

To Play the STILL1-Recorded Clip

► See section 12-2-2. "Playing Clips - Ex. 1."

This example shows how to play the clip recorded in the previous page on the background (PGM bus) through STILL1. Assume that STILL 1 is assigned to the bus button 1.

- (1) Click the **STILL1** tab.
- (2) Select **CLIP** (movie) under **CONTROL PANEL**.
- (3) Select **CLIP** under **READOUT MODE**.
- (4) On the control panel, press 1 (STILL1) on the PGM bus.
- (5) Click the **PLAY** icon. To loop the clip playback, click the **LOOP** icon.

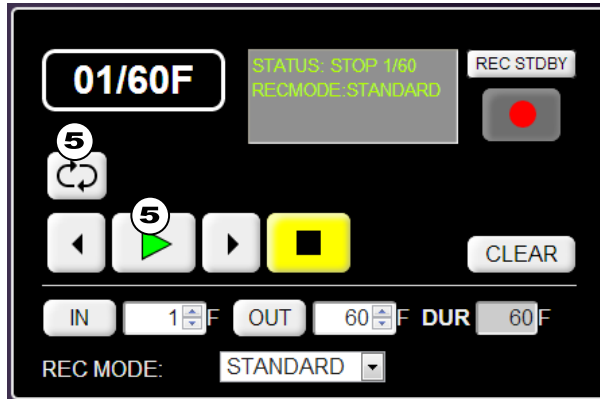

Playback Block Details

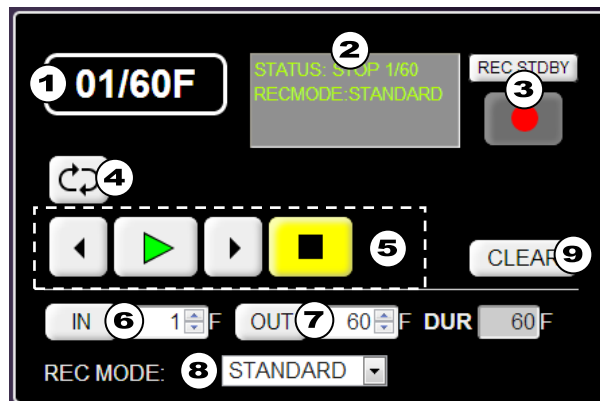

No.	Description
(1)	Displays the current / total durations.
(2)	Displays the clip status.
(3)	Starts recording.
(4)	Loop playback
(5)	One-frame backward, Play, One-frame forward, Stop
(6)	Sets the current frame as the IN-point.
(7)	Sets the current frame as the OUT-point.
(8)	Selects REC MODE. STANDARD : Starts recording by clicking REC STDBY , then REC . DIRECT : Directly starts recording by clicking only REC .
(9)	Clears clip data.

23-11-3. Backing Up/Loading Stills

Click the **BACKUP** tab to display the [STILL - BACKUP] menu page, in which still images can be backed up and loaded manually, and automatic still loading at startup can be set.

► See section 12-1-3. "Backing-up Stills."

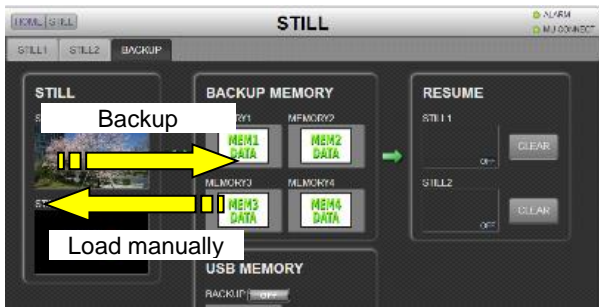

To Back-up Still Images

Drag & drop a still thumbnail from STILL memory to BACKUP MEMORY.

To Load Still Images Manually

Drag & drop an icon from BACKUP MEMORY to STILL memory.

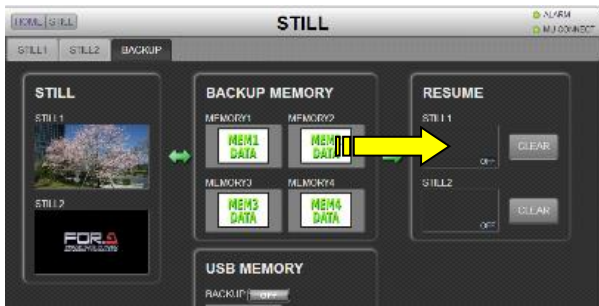

To Set Automatic Still Loading to ON at Startup

Drag an icon to be loaded at switcher startup and drop it onto a RESUME SETTING memory box. **RESUME** will automatically set itself to **ON**. To set **RESUME** to **OFF**, click **CLEAR**.

23-11-4. Backing-up Still and Clip Data using USB Flash Drive

If a USB flash drive is inserted into the switcher USB port, all still and clip data including INPUT STILL data can be backed up in the [STILL - BACKUP] menu page.

► See section 12-3. "Backing-up Still and Clip Data using USB Flash Drive."

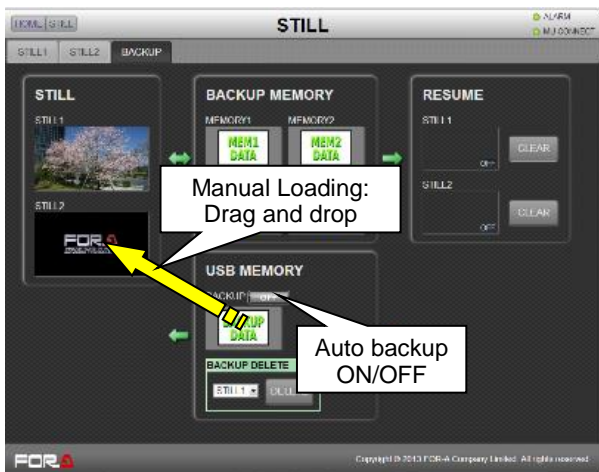

To Set Auto Backup to ON

Set **BACKUP** to **ON** in the USB MEMORY block.

► See section 12-3-2. "Setting Automatic Backup to ON."

To Load Data (manually)

Loading data to STILL or CLIP:

Drag and drop the BACK UP DATA icon. A dialog box will appear. Select **STILL** or **CLIP**.

► See section 12-3-3. "Manually Loading Backup Data."

Loading data to INPUT STILL1-14:

Press **LOAD** under **STL CTRL** in the [SETUP - INPUT - SIGNAL] page. If an INPUT STILL buffer already contains still data, load the backup data after clearing the previous data.

► See section 23-16-2. "SETUP - INPUT."

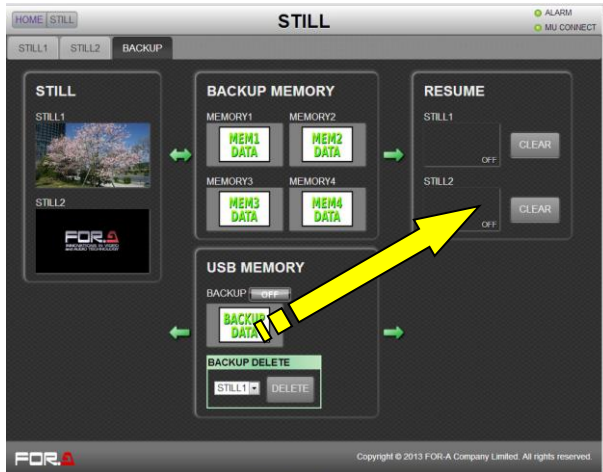

To Load Data Automatically (at startup)

Loading data to STILL1-2 or CLIP1-2

Drag and drop the **BACKUP DATA** icon in USB MEMORY to a **RESUME** memory buffer.

Loading data to INPUT STILL1-14:

Select **BACKUP** under **STL RESUME** in the [SETUP - INPUT - SIGNAL] page.

► See section 23-16-2. "SETUP - INPUT."

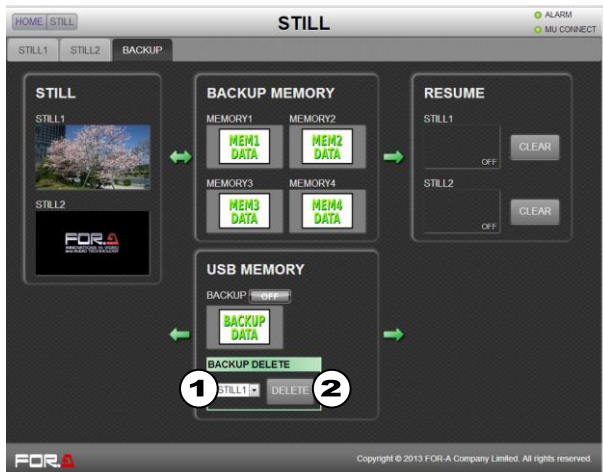

To Delete Still or Clip Data

(1) Select data to be deleted.

(2) Click **DELETE**.

► See section 12-3-4. "Deleting Backup Data."

23-12. MATTE

Click **MATTE** in the HOME screen to display the MATTE menu page.

▶ See section 5-9. "Bus Matte"

To Specify Color for MATT1 and MATT2

▶ See section 5-9-1. "Setting the Matte Color."

Select color by setting the **HSL** values, by selecting a preset color under **RECALL** or using the color circle. To set color on the color circle, specify **Hue** in the outer circle and **Luminance** and **Saturation** on the inner rectangle.

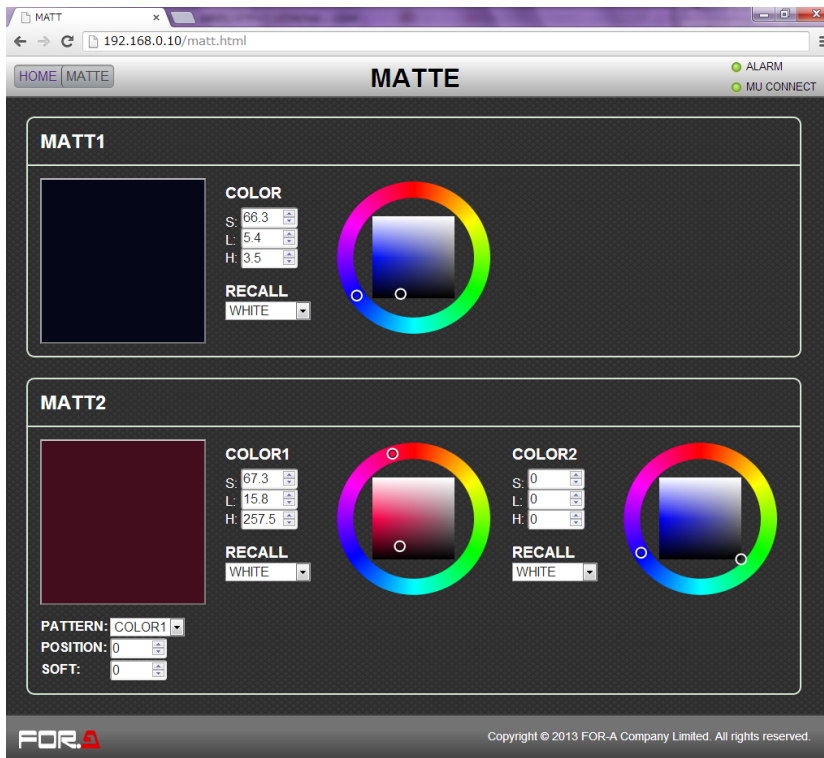

To Specify Gradient Matte (MATT2 only)

▶ See section 5-9-2. "Setting the Gradient Matte."

- (1) Select a start color for the gradient matte under **COLOR1**.
- (2) Select an end color for the gradient matte under **COLOR2**.
- (3) Select a pattern for the gradient matte under **PATTERN**.
- (4) Set the position at **POSITION** and adjust the softness gradient at **SOFT**.

23-13. FILE

Click **FILE** in the HOME screen to display the FILE menu page.

The FILE page allows users to upload still, clip and setting data to the switcher.

NOTE

The FILE menu in the HOME screen allows you to upload any files in any location. The FILE menu on the control panel, however, can upload files only from a connected USB flash drive. But, there exist some restrictions on available or uploadable files depending on the Operation System or devices. After uploading, make sure that your files have been properly uploaded to the switcher.

23-13-1. Uploading a Still Image



- (1) Click on the **STILL** tab.
- (2) Click **Select a file...** to select an image file to be uploaded.
▶ See section 17-4-2. "Downloading Image Files."
- (3) Select an upload destination from STILL1, STILL2 and a Backup Memory and INPUT STILL buffer.
▶ See section 17-4-2. "Downloading Image Files."
- (3) Select a loading type from NORMAL, CENTER and TILE.
- (4) Click **UPLOAD** to upload the file.

23-13-2. Uploading a Clip Data (Sequential Image Files)



- (1) Click on the **CLIP** tab.
- (2) Click **Select files...** to select sequential image files to be uploaded.
▶ See section 12-4-4. "Sending Images to Clip Memory."
- (3) Select an upload destination (**CLIP1** or **CLIP2**).
- (4) Click **UPLOAD** to upload the files.

23-13-3. Uploading a Setting File

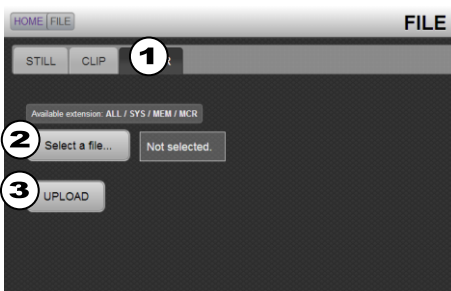

- (1) Click on the **OTHER** tab.
- (2) Click **Select a file...** to select a file to be uploaded.
▶ See section 17-4-1. "Loading Setting Data."
- (3) Click **UPLOAD** to upload the file.
- (4) When uploading system data, a confirmation dialog will appear. Click **YES** to restart the switcher.

23-14. EVENT

Click **EVENT** in the HOME screen to display the EVENT menu page.

► See section 15. "Event Memory"

Storing Events



- (1) Select **STORE** under **CONTROL PANEL** in the center of the screen.
- (2) Click a page then number to select an event number in the event list on the left side.
- (3) Select data to be saved.
- (4) Click **STORE EXEC** to store data to the event.
- (5) Clicking **PREFERENCES** allows you to create a default set of event data.
► See section 15-4-3. "Setting the User Default Menu when Storing an Event."

Recalling Events



- (1) Select **RECALL** under **CONTROL PANEL** in the center of the screen. When using the Direct mode, set **DIRECT RECALL** to **ON**.
- (2) Click a page then number to select an event from the event list on the left side. The event will be loaded if in Direct mode.
- (3) If Direct mode is OFF, the data stored in the event will be displayed. Select all or desired data to be loaded.
- (4) Click **RECALL EXEC** to load the event.

23-15. MACRO

Click **MACRO** in the HOME screen to display the MACRO menu page.

The Macro page allows you to execute and edit macros. Macros, however, cannot be created and saved on web browsers.

► See section 16. "Macros"

23-15-1. To Execute Macros



(1) Click the **FILE** tab in the upper left corner of the screen to display the [MACRO - FILE] page.

(2) Select a macro from the macro list on the left side of the screen.

(3) Click **PLAY**.

23-15-2. To Edit Macros (Web Control Only)

Note that macros can be edited on web browsers, but not on control panels.

Action deletion and duration settings are available.



(1) Select a macro from the macro list in the [MACRO - FILE] page.

(2) Click the **EDIT** tab in the upper left corner of the screen to display the [MACRO - EDIT] page.

(3) The action list of the selected macro is displayed on the left side of the screen. Select an action to be edited.

(4) Change a duration (period until the next action) under **STEP DURATION**, then click **EXEC**.

(5) Clicking **DELETE** deletes the action from the macro.

(6) Add a step by clicking **OVER WR**, **INSERT** or **ADD** (overwrite, insert in front or insert at back of cursor).

23-15-3. Assigning a Macro to a KEY/AUX Bus Button

This menu page allows users to assign macros to the KEY/AUX bus buttons.

► See Step 2 in section 16-4-1. "Changing KEY/AUX Bus Buttons to Macro EXE Buttons."



23-16. SETUP

Click **SETUP** in the HOME screen to display the SETUP menu page.

23-16-1. SETUP - SYSTEM

Click the **SYSTEM** tab to display and set the SYSTEM menu.

The screenshot shows the 'SETUP' menu with the 'SYSTEM' tab selected. The menu is organized into several sections, each with a 'GO TO TOP' button:

- FORMAT**: Includes fields for FORMAT (1080/59.94), ASPECT (16:9), and SW TIMING (ODD).
- REF IN**: Includes fields for TYPE (BB) and H PHS (0).
- REF OUT**: Includes fields for TYPE (BB), H PHS (0), and V PHS (0).
- ARCNET**: Includes a field for MU ID (250).
- ETHERNET**: Includes fields for IP ADDRESS (192.168.0.10), NET MASK (255.255.255.0), GATEWAY (192.168.0.1), and MAC ADDRESS (00-10-B1-07-CF-01).
- RS-422**: Includes a table for PORT1 and PORT2 configurations with columns for FUNC, BAUD, and PARITY.
- TIME**: Includes fields for DATE (2013/00/27), TIME (15:42), UPDATE (EXEC), 1st CHECK (OFF), TIME ZONE (UTC 0:00), SUMMER TIME (OFF), SNTP SERVER ADDR (0.0.0.0), UPDATE TIME (00:00), and INTERVAL (OFF).
- INIT**: Includes fields for INIT (OFF) and LOAD (OFF).
- REBOOT**: Includes a button labeled 'LXLC'.

At the bottom of the screen, there is a 'FOR-A' logo and a copyright notice: 'Copyright © 2013 FOR-A Company Limited. All rights reserved.'

Click a button to go to the desired menu block. See the operation manual main pages for details on each function.

FORMAT

- ▶ See section 3-4. "System Signal Format Selection at Initial Use"
- ▶ See section 18-1. "Selecting System Signal Format"

REF IN

- ▶ See section 18-3-1. "To Set Reference Input"

REF OUT

- ▶ See section 18-3-2. "To Set Reference Output"

ARCNET

- ▶ See section 20-5-1. "Connecting AUX Boxes."
- * Available only when HVS-XT100ARC is installed.

ETHERNET

- ▶ See section 12-4-1. "LAN Connection."
- ▶ See section 23-1. "System Setup.". "Ethernet"

RS-422

- ▶ See Refer to the following sections.

Connector	2-4-1
Tally Unit	20-1-3
VTR/VDCP	20-2-1
Router	20-3-1
Editor	20-4-1
HVS-30RU	20-7-1

TIME

- ▶ See section 3-5 or 18-4. "Setting Date, Time and Time Zone at Initial Use."

INIT

- ▶ See section 19-2. "System Initialization."

REBOOT

- ▶ See section 19-1. "Rebooting System."

23-16-2. SETUP - INPUT

Click the **INPUT** tab to display and set the INPUT menu.

The screenshot shows the 'SETUP' interface with the 'INPUT' tab selected. The 'SIGNAL' section contains a table for 8 input channels (IN01-IN08) with columns for FORMAT, RESIZE, FS, STL CONTROL, STL FREEZE, and STL RESUME. The 'XPT DELAY' section has a 'BLK' field set to 0. The 'PROC AMP' section includes a 'COMMON' table for CLIP (White-Lv, Black-Lv, Chroma) and a table for individual input channels (IN01-IN12) with columns for ENABLE, ChmGain, Hue, LumGain, Setup, and SIGNAL. The 'SIDE PANEL' section has a 'SIDE MATT' table with columns for ENABLE and SIGNAL.

Click a button to go to the desired menu block. See the operation manual main pages for details on each function.

SIGNAL

► See the following sections.

FORMAT	5-3
RESIZE	5-3
FS	5-7
STL CTRL *	5-4 and 23-11-4
STL FREEZE	5-4
STL RESUME *	23-11-4

* The **STL CTRL LOAD** button and **STL RESUME** are displayed only when a USB flash drive is connected to the switcser.

► See the following sections.

XPT DELAY	5-6
PROC AMP	5-8-1 and 5-8-2
SIDE PANEL	5-5

The 'RENAME' menu shows a table with columns 'LONG' and 'SHORT'. The 'BLK' row has 'BLACK' and 'BLK'. The 'IN01' row has 'INPUT01' and 'IN01'. The 'IN02' row has 'INPUT02' and 'IN02'. The 'IN03' row has 'INPUT03' and 'IN03'.

RENAME

► See section 5-1. "How to Assign User Names to Sources"

The 'BUS ASSIGN' menu shows a table with columns 'BUTTON', 'SIGNAL', 'INHIBIT', 'BUTTON', 'SIGNAL', and 'INHIBIT'. The '01' row has 'INPUT01', 'OFF', 'SR01', 'MAT2', and 'OFF'. The '02' row has 'INPUT02', 'OFF', 'SR02', 'NONL', and 'OFF'.

BUS ASSIGN

► See section 5-2. "How to Assign Sources to Bus Buttons"

The 'COLORBAR' menu has a 'TYPE' dropdown menu currently set to 'SMPTE'.

COLORBAR

Selects the color bar type between SMPTE and ARIB.

23-16-3. SETUP - OUTPUT

Click the **OUTPUT** tab to display and set the OUTPUT menu.

The screenshot shows the 'SETUP' interface with the 'OUTPUT' tab selected. The interface is divided into several sections, each with a 'GO TO TOP' button below it.

MARKER

	ENABLE	MARKER	SIDECUT
AUX1:	OFF	OFF	OFF
AUX2:	OFF	OFF	OFF
AUX3:	OFF	OFF	OFF
AUX4:	OFF	OFF	OFF
AUX5:	OFF	OFF	OFF
AUX6:	OFF	OFF	OFF
AUX7:	OFF	OFF	OFF
AUX8:	OFF	OFF	OFF
HDMI:	OFF	OFF	OFF
ASPECT:	4:3	SIZE:	70 %
CENTER:	OFF		

CLEAN/PREVIEW

	KEY1	KEY2	DSK1	DSK2
M/E CLN:	OFF	OFF	OFF	OFF
M/E PRV:	OFF	OFF	OFF	OFF

ANCI SWAP

PGM: SOURCE: EACH LV: 0 PRV: SOURCE: EACH

ANCI THROUGH

AUX1:	OFF	AUX2:	OFF
AUX3:	OFF	AUX4:	OFF
AUX5:	OFF	AUX6:	OFF
AUX7:	OFF	AUX8:	OFF

OUT XPT

AUX	XPT	INHIBIT	TRANS	
			ENABLE	RATE
AUX1:	INPUT01	OFF	OFF	0
AUX2:	INPUT01	OFF	OFF	0
AUX3:	INPUT01	OFF	OFF	0
AUX4:	INPUT01	OFF	OFF	0
AUX5:	INPUT01	OFF	OFF	0
AUX6:	INPUT01	OFF	OFF	0
AUX7:	INPUT01	OFF	OFF	0
AUX8:	INPUT01	OFF	OFF	0
HDMI:	XPT	M/E KEY	SIGNAL	
HDMI:	PGM	M/E KEY	MLKLY	

Click a button to go to the desired menu block. See the operation manual main pages for details on each function.

MARKER

- ▶ See section 6-7. "Safety Area Markers"

CLEAN/PREVIEW

- ▶ See section 6-2. "Preview Set Up"
- ▶ See section 6-3. "Clean Set Up"

ANCI SWAP

- ▶ See section 6-8-2. "Ancillary Data in PGM and PREV bus Signals."

ANCI THROUGH

- ▶ See section 6-8-1. "To Pass Incoming Ancillary Data on AUX Outputs."

OUT XPT (AUX)

- ▶ See section 6-1. "Aux Outputs."

OUT XPT (HDMI)

- ▶ See section 6-5. "HDMI Output."

OUT XPT (M/E KEY)

- ▶ See section 6-4. "KEY OUT Set Up."



MV

- ▶ See section 13. "Multiviewer."
- ▶ See the following sections for details

DIV / WINDOW 13-2
 USER PRESET 13-5

SIGNAL 13-3
 CHARA 13-4-1
 AUDIO 13-4-2
 SF AREA 13-4-3
 TITLE X / Y 13-4-1

BORDER COLOR 13-4-4
 TALLY 13-4-5

MV TALLY LINK TABLE

- ▶ See section 13-4-5. "On-air Tally."

RENAME

- ▶ See section 13-4-1. "Titles" - Changing Output Signal Names.

OPTION (HVS-XT100 only)

- ▶ See section 6-6. "Setting Up Additional Outputs."

23-16-4. SETUP - PANEL

Click the **PANEL** tab to display and set the PANEL menu.

The screenshot shows the 'SETUP' interface with the 'PANEL' tab selected. It contains several sections:

- UTILITY:** SWIPE INPUT: OFF
- TRS CTRL:** BUS TYPE: PIP
- OU USER BUTTON:** A table with 8 rows (OU-01 to OU-08) and 5 columns (USER BUTTON, TYPE, FUNC, TRIGGER EDGE, TRIGGER FUNC). All TYPE and TRIGGER EDGE are set to 'NON' and 'ON' respectively. FUNC is '(NOT ASSIGN)' and TRIGGER FUNC is '(NOT USED)'.
- RU USER BUTTON:** A table with 2 rows (RU-01, RU-02) and 5 columns. TYPE is 'OTHER', FUNC is 'AUX XPT SELECT' and 'ME KEY XPT SELECT', TRIGGER EDGE is 'ON', and TRIGGER FUNC is '(NOT USED)'.

Click a button to go to the desired menu block. See the operation manual main pages for details on each function.

UTILITY (if running the GUI on a tablet PC)

SWIPE INPUT: Set to ON or OFF

If set to **ON**, swipe gestures can be used to change numeric values. (See the figure below.)

TRS CTRL

▶ See section 7-2. "Button Switching Mode in the M/E bus."

OU USER BUTTON

▶ See section 14. "USER Buttons."

User buttons can be executed in the pop-up menu on the GUI.

▶ See section 23-18-2. "Executing User Buttons."

RU USER BUTTON (HVS-30RU connection required)

▶ See section 20-7-3. "Setting USER Buttons."

◆ Changing Numeric Values Using Swipe

- (1) Change **SWIPE INPUT** to **ON** in the SETUP-PANEL page. (See above.)
- (2) Focus on a parameter box (numeric value).
- (3) Swipe up/down or right/left to increase/decrease the parameter value.
The initial swipe direction determines the effective swipe actions (up/down or left/right).

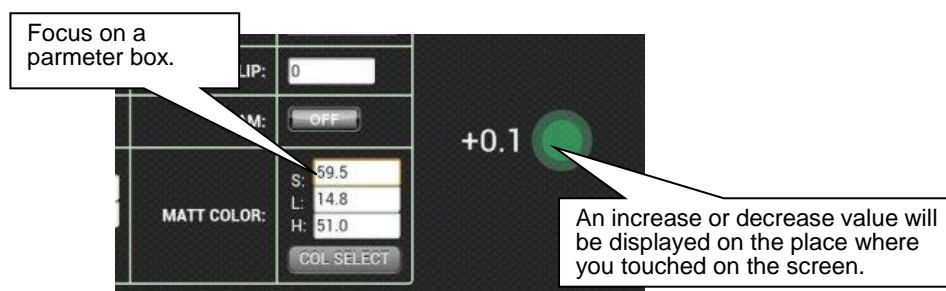

- * Note that the **SWIPE INPUT** setting is saved in your Web browser. If the switcher IP address is changed, set the SWIPE INPUT again.

23-16-5. SETUP - GPI/TLY

Click the **GPI/TLY** tab to display and set the GPI/TALLY menu.

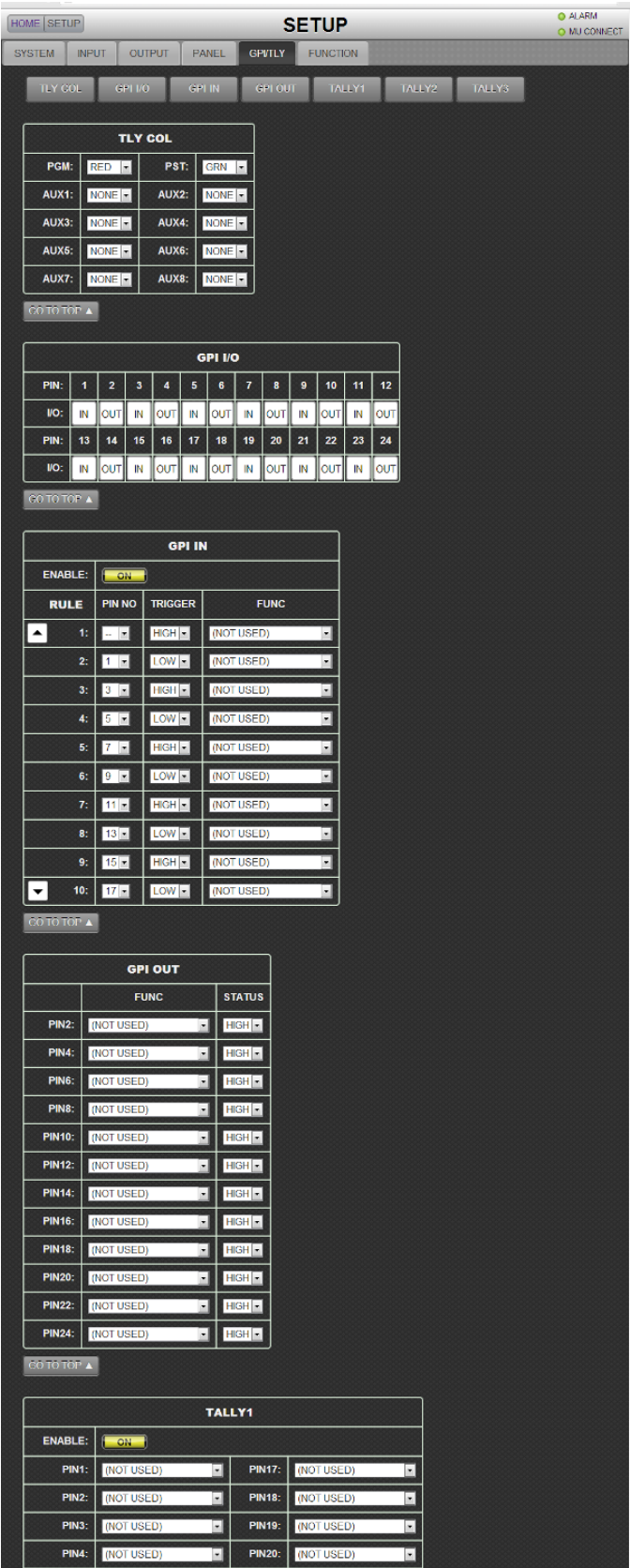

Click a button to go to the desired menu block. See the operation manual main pages for details on each function.

TLY COL (TALLY COLOR)

- ▶ See section 20-1-2. "Pin Assignment Examples" - Tally Outputs.

GPI I/O

- ▶ See section 20-1-1. "GPI IN/TALLY OUT Connector."
- ▶ See section 20-1-2. "Pin Assignment Examples."

GPI IN

- ▶ See section 20-1-2. "Pin Assignment Examples" - GPI Inputs.

GPI OUT

- ▶ See section 20-1-2. "Pin Assignment Examples" - GPI Outputs.
- ▶ See section 20-1-2. "Pin Assignment Examples" - Tally Outputs.

GPI I/O displays only output pins, which are set under **GPI I/O** above.

TALLY1 to TALLY3

- ▶ See section 20-1-3. "Sending Tally Signals to Tally Units."

23-16-6. SETUP - FUNCTION

Click the **FUNCTION** tab to display and set the FUNCTION menu.

The screenshot shows the FUNCTION menu with the following settings:

KEY/DSK

TRS EDGE:	<input type="checkbox"/> ON	
KEY LINK:	<input type="checkbox"/> ON	
DSK ASSIGN:	DSK1	DSK2
	<input type="text" value="ME"/>	<input type="text" value="ME"/>

GO TO TOP ▲

VIRTUAL STANDARD

PATT	1. CAMx4 CGx1 FREE ME1			EXEC
COMPO	ENABLE	DELAY	TLY OUT	
1:	<input type="checkbox"/> ON	3	OFF	
2:	<input type="checkbox"/> ON	3	VR2-2	
3:	<input type="checkbox"/> OFF	3	OFF	
4:	<input type="checkbox"/> OFF	3	OFF	

GO TO TOP ▲

Click a button to go to the desired menu block. See the operation manual main pages for details on each function.

KEY/DSK

- ▶ See section 8-11-5. "Endpoint Processing for DVE Transitions"
- ▶ See section 9-3-1. "Key Link"
- ▶ See section 8-5-1. "Where DSK Images Appear"

VIRTUAL STANDARD

VIRTUAL ADVANCED

- ▶ See the HVS-XT100VR Operation manual.

The screenshot shows the VIRTUAL ADVANCED menu with the following settings:

VIRTUAL ADVANCED

GENERAL

ENABLE	LAN CNT	PRESET	INIT
<input type="checkbox"/> ON	<input type="text" value="P/P"/>	<input type="text" value="USER1"/>	EXEC
SAVE			

VR XPT

NO	ENABLE	DUMMY-XPT	CAMERA	SELECT	TALLY
VR01:	<input type="checkbox"/> ON	BLK	IN01	CG	1
VR02:	<input type="checkbox"/> ON	IN02	IN02	CG	2

CG COMPO

COMPO	ENABLE	DELAY	TLY OUT	TYPE	SHARED	CG IN	DL IN	AUX OUT
1:	<input type="checkbox"/> ON	3	OFF	FREE ALL	NON	BLK	BLK	NONE
2:	<input type="checkbox"/> ON	3	VR2-2	FIX ME B BUS	ALL	BLK	BLK	AUX1

The screenshot shows the AUX LINK menu with the following settings:

AUX LINK

ENABLE: OFF

AUX GROUP	MASTER	SLAVE1	SLAVE2	SLAVE3
1:	<input type="checkbox"/> OFF	<input type="checkbox"/> OFF	<input type="checkbox"/> OFF	<input type="checkbox"/> OFF
2:	<input type="checkbox"/> OFF	<input type="checkbox"/> OFF	<input type="checkbox"/> OFF	<input type="checkbox"/> OFF
3:	<input type="checkbox"/> OFF	<input type="checkbox"/> OFF	<input type="checkbox"/> OFF	<input type="checkbox"/> OFF
4:	<input type="checkbox"/> OFF	<input type="checkbox"/> OFF	<input type="checkbox"/> OFF	<input type="checkbox"/> OFF
5:	<input type="checkbox"/> OFF	<input type="checkbox"/> OFF	<input type="checkbox"/> OFF	<input type="checkbox"/> OFF

AUX LINK

- ▶ See section 6-9. "AUX LINK"

SMART DIRECT			
ENABLE:	<input type="button" value="OFF"/>		
IP ADDRESS:	<input type="text" value="0"/>	<input type="text" value="0"/>	<input type="text" value="0"/>

GO TO TOP ▲

4K CONTROL				
CONTROL:	<input type="button" value="OFF"/>		2K ASSIGN INHIBIT:	<input type="button" value="DISABLE"/>
IN/OUT	IN01-04:	<input type="button" value="2K"/>	OUT1-4:	<input type="button" value="2K"/>
	IN05-08:	<input type="button" value="2K"/>	OUT5-8:	<input type="button" value="2K"/>
	IN09-12:	<input type="button" value="2K"/>		
KEYER	KEY1	KEY2	DSK1	DSK2
EXT CTRL:	<input type="button" value="OFF"/>	<input type="button" value="OFF"/>	<input type="button" value="OFF"/>	<input type="button" value="OFF"/>
ASSIGN:	<input type="button" value="U-L"/>		<input type="button" value="U-L"/>	<input type="button" value="U-L"/>

4K KEYSER LINK			
ENABLE:	<input type="button" value="OFF"/>		
KEY GROUP	MASTER	SLAVE1	SLAVE2
1:	<input type="button" value="OFF"/>	<input type="button" value="OFF"/>	<input type="button" value="OFF"/>
LINK GROUP	MASTER	SLAVE1	SLAVE2
1:	<input type="button" value="OFF"/>	<input type="button" value="OFF"/>	<input type="button" value="OFF"/>
2:	<input type="button" value="OFF"/>	<input type="button" value="OFF"/>	<input type="button" value="OFF"/>
3:	<input type="button" value="OFF"/>	<input type="button" value="OFF"/>	<input type="button" value="OFF"/>
4:	<input type="button" value="OFF"/>	<input type="button" value="OFF"/>	<input type="button" value="OFF"/>
5:	<input type="button" value="OFF"/>	<input type="button" value="OFF"/>	<input type="button" value="OFF"/>
6:	<input type="button" value="OFF"/>	<input type="button" value="OFF"/>	<input type="button" value="OFF"/>
7:	<input type="button" value="OFF"/>	<input type="button" value="OFF"/>	<input type="button" value="OFF"/>
8:	<input type="button" value="OFF"/>	<input type="button" value="OFF"/>	<input type="button" value="OFF"/>
9:	<input type="button" value="OFF"/>	<input type="button" value="OFF"/>	<input type="button" value="OFF"/>
10:	<input type="button" value="OFF"/>	<input type="button" value="OFF"/>	<input type="button" value="OFF"/>

GO TO TOP ▲

SMART DIRECT

► See section 21. "SmartDirect Control (Option)"

4K CONTROL

► See section 22-2. « 4K Mode”

* Note that the AUX LINK block is not available when **CONTROL** is set to **ON**.

4K KEYSER LINK

► See section 22-2-3. « 4K Key Links »

23-16-7. SETUP - STATUS

Click **STATUS** tab to display the STATUS menu page.

► See section 18-6. "Status Information"

The screenshot shows the 'STATUS' menu page with the following sections:

ALARM

FAN1:	NOR	FAN2:	NOR
PS1:	NOR	PS2:	NOR
GENLOCK:	Internal Lock		

GO TO TOP ▲

VERSION

SOFT	MAIN	GUI	OU	RU
	v1.05.0	v1.05.0	v1.00.0	---

FPGA	MU	GL	SDI	ME
	v01-02	v02-01	v02-05	

FPGA	OU	DEV1	DEV2	DEV3
	v01-00	v01-00	v01-00	

GO TO TOP ▲

OPTION

SLOT-A:	(not install)	HVS-XT100ARC:	---
SLOT-B:	(not install)	HVS-XT100ED:	INSTALLED
SLOT-C:	(not install)	HVS-XT100VR:	INSTALLED
		HVS-XT100EXP3G:	INSTALLED

OPTION (HVS-AUXxxA)

	UNIT1	UNIT2	UNIT3	UNIT4	UNIT5
SOFT	---	---	---	---	---
CPLD	---	---	---	---	---

GO TO TOP ▲

LOG

```
<14/07/23 09:45:29> HVS-XT100 start up. Genlock is internal.
<14/07/22 23:34:14> HVS-XT100 start up. Genlock is internal.
<14/07/22 23:32:15> HVS-XT100 start up. Genlock is internal.
```

Click a button to go to the desired menu block. See the operation manual main pages for details on each function.

ALARM

► See section 18-6-1. "Checking Alarm Status"

VERSION

► See section 18-6-2. "Verifying Versions"

OPTION

► See section 18-6-3. "Installed Options"

LOG

Displays alarm log.

23-17. EXT IF

Click **EXT IF** in the HOME screen to display the EXT I/F menu page.

23-17-1. EXT IF - EDITOR (Option)

Click the **EDITOR** tab to display and set the EDITOR menu.

▶ See section 20-4. "Editor Control (HVS-XT100ED)"

23-17-2. EXT IF - TSL TLY

Click the **TSL TLY** tab to display and set the TSL TALLY menu.

The TSL TALLY page allows you to set tally information when sending tallies to a downstream devices such as a multiviewer using TSL tally protocol via RS-422.

▶ See section 20-3. "Router Control." Ask your FOR-A reseller for details on TSL Tally connections.

23-17-3. EXT IF - VTR/VDCP

Click the **VTR/VDCP** tab to display and set the VTR/VDCP menu.

▶ See section 20-2. "VTR / VDCP Control"

Before displaying the VTR/VDCP menu page, assign a channel (VTR1-2 or VDCP1-2) to an RS-422 port in the [SETUP - SYSTEM - RS-422] page. (VTR/VDCP controllers will not be displayed in the menu page if channels are not assigned to ports.)

▶ See section 23-16-1. "SETUP - SYSTEM"-RS-422.

▶ See section 20-2-1. "RS-422 Port Settings (VTR/VDCP)."

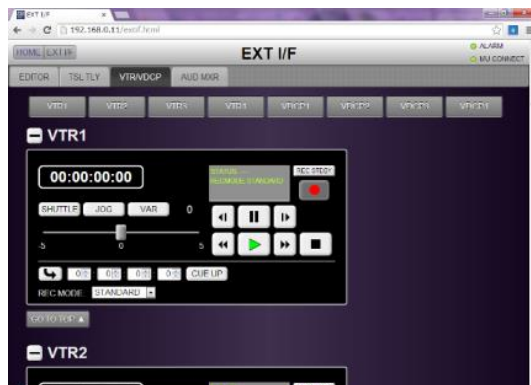

VTR channel controller

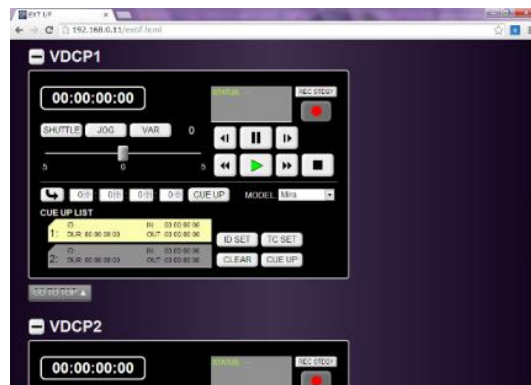

VDCP channel controller

For VDCP channels, select **Mira** or **HVS-5ECD** under MODEL in the right center of the panel.

▶ See section 20-2-2. "Controlling the VTR"- Selecting the VDCP Type.

VTR Control

► See section 20-2-3. "Playback and Recording."



No.	Description
(1)	Displays the current time code.
(2)	Displays the VTR status.
(3)	REC button. Pressing the button starts recording. (See (7) REC MODE below.)
(4)	SHUTTLE/JOG/VARIABLE play buttons and playback speed controller
(5)	One-frame Back, Pause, One-frame Forward Rewind, Play, Fast Forward, Stop
(6)	Sets an IN point. Clicking the arrow sets the current time code to the IN point. CUE UP : Moves the play-head to the IN point time code.
(7)	Sets the REC mode. STANDARD : Starts recording by pressing REC STDBY , then REC . DIRECT : Stars recording by just pressing REC .

VDCP Control

► See section 20-2-4. "VDCP Operation"

◆ Recording Video

- (1) Click **REC STDBY**. A dialog box will pop-up.
- (2) Set the recording time in the dialog box. If set to 00:00:00:00, recording continues until **STOP** is clicked.
- (3) Enter the CLIP ID (clip name) to which the clip is saved.
- (4) Click **CLOSE** to close the pop-up dialog.
- (5) Click **REC** to start recording.
- (6) To stop recording, click **STOP**. (Recording will automatically stop if the duration value is set.)

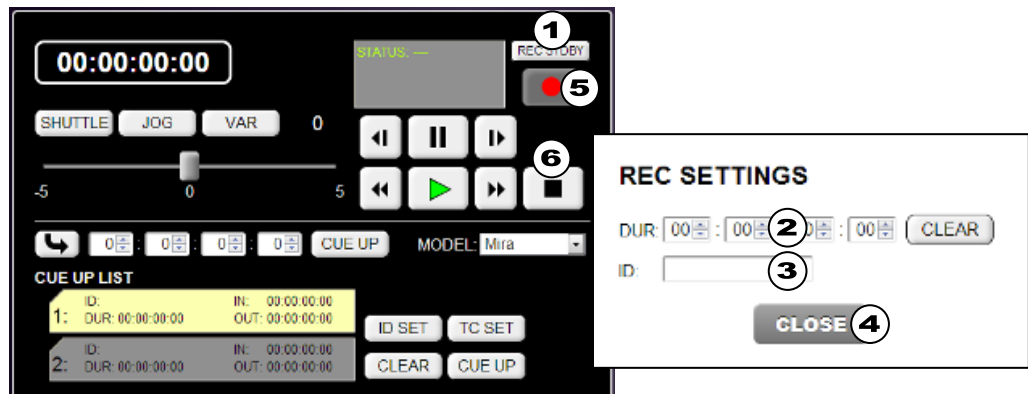

◆ Setting Up Playlists

Two playlist, List 1 and 2, can be saved to the switcher. To copy the playlist contents, drag and drop from one list to the other.

- (1) Click to select **List 1** or **2** under CUE UP LIST. (The selected list will turn to yellow.)
- (2) Click **ID SET** to pop-up the **ID SELECT** dialog box.
- (3) Select a clip to be played in the dialog box.
- (4) Click **SELECT**. The selected clip will be cued up (and displayed in the List 1 or List 2 label.)
- (5) Click **CLOSE** to close the dialog box.
- (6) Click **TC SET** to pop-up the **TC SETTINGS** dialog box.
- (7) In this dialog, set **IN** and **OUT** points (or **Duration**). (Once the values are set, they will be displayed on the List 1 or 2 label.) If 00:00:00:00 is set for both IN and OUT points, clips will be played back from Start to End. Clicking a **CUE UP** on the dialog moves the play-head to the IN or OUT timecode.
- (8) Click **CLOSE** to close the dialog box.

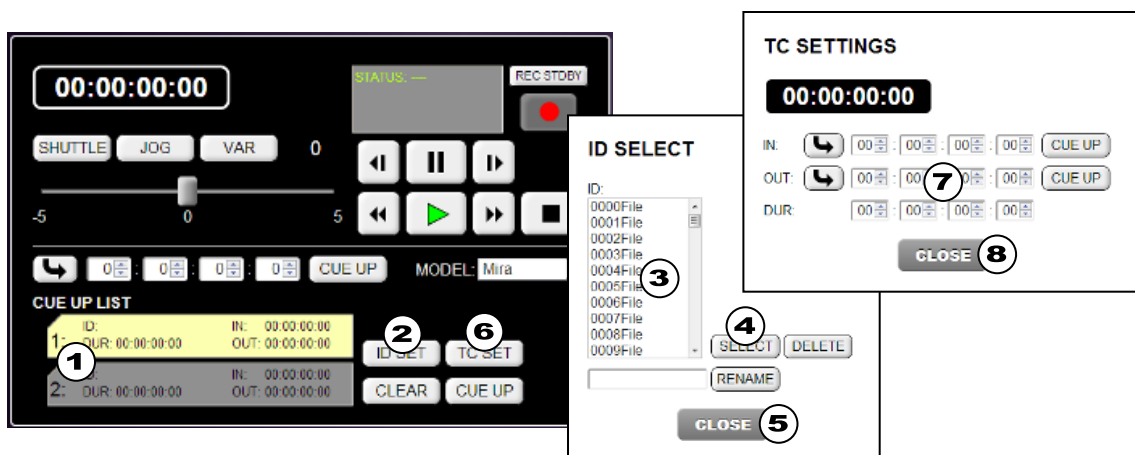

◆ Playing Clips

- (1) Click to select List 1 or 2 under CUE UP LIST. (The selected list will turn to yellow.)
- (2) Click **CUE UP** to cue up the clip.

Pressing **CUE UP(A)** sets the time code value displayed on the left of **CUE UP** to the IN point and the end of the clip to the OUT point.

Pressing **CUE UP(B)** sets the IN and OUT point values saved in the playlist to the IN and OUT points.

- (3) Click **Play** to play back the clip. (All VTR Controller functions are available.)

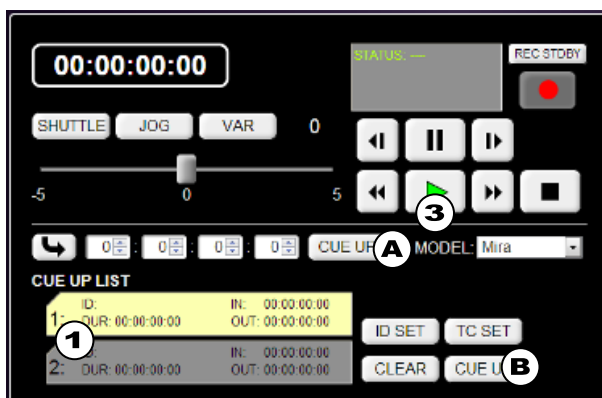

◆ **Changing CLIP ID**

▶ See 20-2-4. "VDCP Operation" - Changing CLIP ID and Deleting Clips.

- (1) Click **ID SET** to pop-up the **ID SELECT** dialog box.
- (2) Select a clip ID to be changed.
- (3) Enter a new ID (name).
- (4) Click **RENAME** to rename the clip.
- (5) Click **CLOSE** to close the dialog.

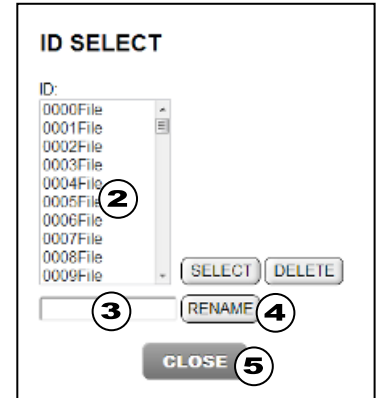
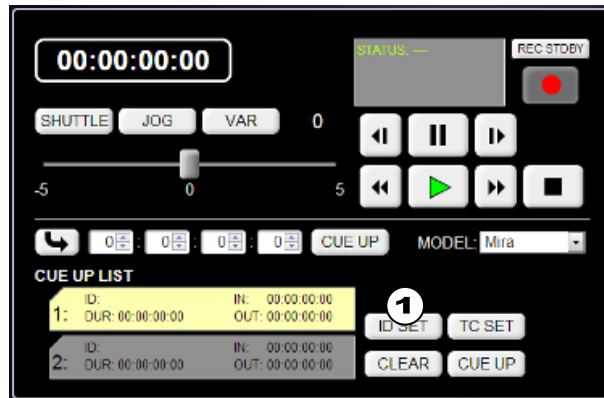

◆ **Deleting Clips**

▶ See 20-2-4. "VDCP Operation" - Changing CLIP ID and Deleting Clips.

- (1) Click **ID SET** to pop-up the **ID SELECT** dialog box.
- (2) Select a clip ID to be deleted.
- (3) Click **DELETE**.
- (4) A confirmation message will be displayed. Click **OK** to delete the clip.
- (5) Click **CLOSE** to close the dialog.

23-17-4. EXT I/F - ROUTER

Click the **ROUTER** tab to display the ROUTER setting page.

► See section 20-3. "Router Control."

Before displaying the ROUTER menu page, assign the ROUTER channel to an RS-422 port in the [SETUP - SYSTEM - RS-422] page.

► See section 23-16-1. "SETUP - SYSTEM"-RS-422.

► See section 20-3-1. "RS-422 Port Settings."

The screenshot shows the 'EXT I/F' configuration page for a 'ROUTER'. It includes sections for 'OU ASSIGN' (with 'DST BTN' and 'SRC BTN' tables), 'XPT' (Crosspoint) with a grid and 'CONTROL PANEL' buttons, and 'NAME LINK' with 'LINK' and 'DISPLAY' options. A blue callout box points to the 'CONTROL PANEL' buttons with the text 'CONTROL PANEL Setting'.

Click a button to go to the desired menu block. See the operation manual pages for details on each function.

OU ASSIGN

► See section 20-3-4. "Crosspoint Switches with Control Buttons (Setup)"

To assign ROUTER ENABLE to a USER button, go to the [SETUP -PANEL] menu page

► See section "23-16-4. "SETUP -PANEL"- OU USER BUTTON.

XPT

The CONTROL PANEL button changes the crosspoint switching mode.

► See the next page.

NAME LINK

► See section 20-3-2. "Setting MFR Link."

Note that NAME LINK is available only for FOR-A MFR Series routers. To use the NAME LINK for other routers, two RS-422 connections are required. Ask your FOR-A reseller for mode details.

There are two ways to switch crosspoints on the GUI depending on the CONTROL PANEL setting.

- Specify each crosspoint (CONTROL PANEL setting: **DIRECT**)
- Use the TAKE function (CONTROL PANEL setting: **PRESET**)

Crosspoint Switches through each crosspoint specification (CONTROL PANEL setting: DIRECT)

(1) Set the desired level(s) to ON.

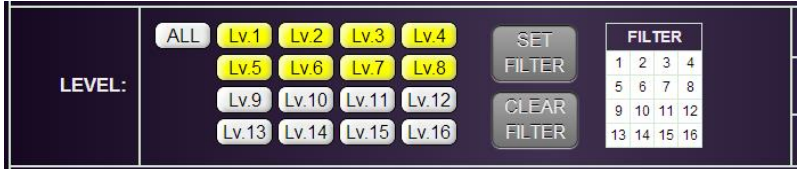

- * The FILTER function allows you to select levels to be hidden as shown below.
SET FILTER: Displays only the selected levels.
CLEAR FILTER: Clears filtering.

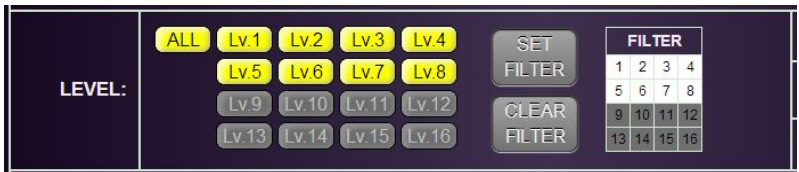

(MFR Series routers support Level 1-8.)

- (2) Click to select a crosspoint.
- (3) Click the crosspoint again to enable the selection.

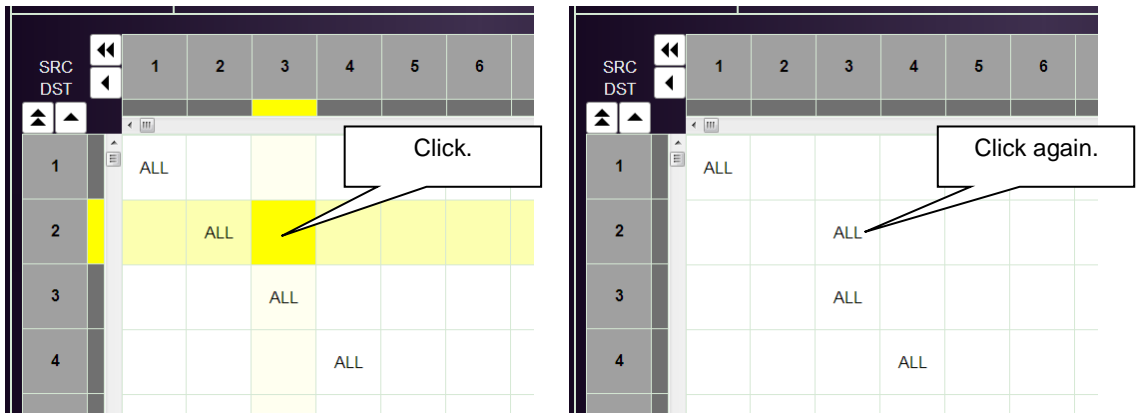

- (4) To unselect the crosspoint, click a Destination number.
 (Clicking a Destination number without selecting a crosspoint will change the displayed grid area.)

Crosspoint Switches using the TAKE function (CONTROL PANEL: PRESET)

- (1) Set the desired level(s) to ON.
 - (2) Click to select a crosspoint, and click the crosspoint again to change the character to red .
 - (3) Repeat Step (2), as needed.
- * Up to 256 crosspoints can be set.
- (4) Click **TAKE**. A confirmation dialog will appear. Click **OK** to perform the assigned crosspoint switches. (Clicking CANCEL clears all crosspoint settings.)

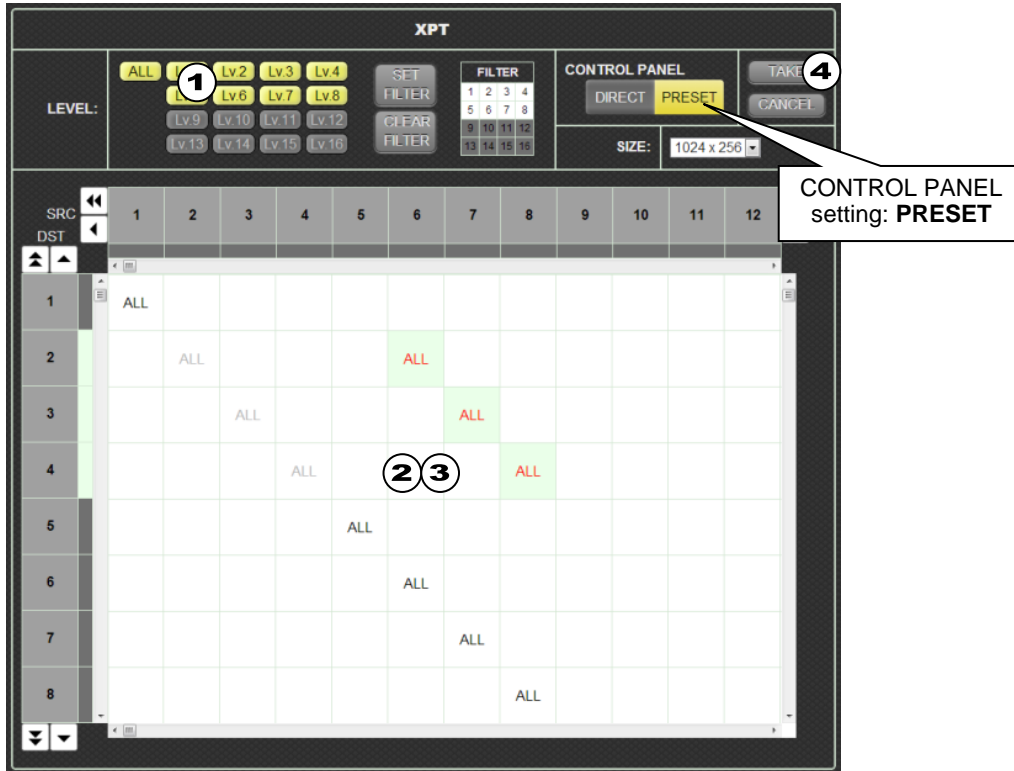

Saving and Loading Crosspoint Settings

All crosspoint selections on the router can be saved as a set of setting data, which is stored in the switcher and can be loaded, as needed.

► See section 20-3-7. "Saving and Loading Crosspoints."

- (1) Set CONTROL PANEL to **DIRECT**.
- (2) To save the current crosspoint settings, click **SAVE**. To load the stored data, click **LOAD**.

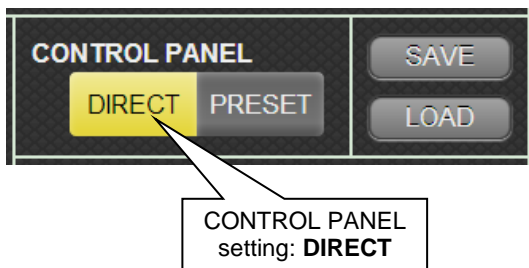

23-17-5. EXT I/F - ROUTER LINK

Click the **ROUTER LINK** tab to display the ROUTER LINK setting page.
 ▶ See section 20-3-9. "Router Link."

HOME EXT I/F
EXT I/F
● ALARM
● MU CONNECT

EDITOR
TSL TLY
VTR/VDCP
ROUTER
RTR LINK
AUX UNIT

ROUTER LINK

BUS							XPT		
	INPUT	RTR DST	ENABLE		INPUT	RTR DST	ENABLE		RTR SRC
A BUS:	NONE ▾	1 ▾	OFF	CK:	NONE ▾	1 ▾	OFF	▲ RX01:	NONE ▾
B BUS:	NONE ▾	1 ▾	OFF	EFF1:	NONE ▾	1 ▾	OFF	RX02:	NONE ▾
KEY1 INS:	NONE ▾	1 ▾	OFF	EFF2:	NONE ▾	1 ▾	OFF	RX03:	NONE ▾
KEY1 SRC:	NONE ▾	1 ▾	OFF	AUX1:	NONE ▾	1 ▾	OFF	RX04:	NONE ▾
KEY2 INS:	NONE ▾	1 ▾	OFF	AUX2:	NONE ▾	1 ▾	OFF	RX05:	NONE ▾
KEY2 SRC:	NONE ▾	1 ▾	OFF	AUX3:	NONE ▾	1 ▾	OFF	RX06:	NONE ▾
DSK1 INS:	NONE ▾	1 ▾	OFF	AUX4:	NONE ▾	1 ▾	OFF	RX07:	NONE ▾
DSK1 SRC:	NONE ▾	1 ▾	OFF	AUX5:	NONE ▾	1 ▾	OFF	RX08:	NONE ▾
DSK2 INS:	NONE ▾	1 ▾	OFF	AUX6:	NONE ▾	1 ▾	OFF	RX09:	NONE ▾
DSK2 SRC:	NONE ▾	1 ▾	OFF	AUX7:	NONE ▾	1 ▾	OFF	▼ RX10:	NONE ▾
				AUX8:	NONE ▾	1 ▾	OFF	ENABLE:	OFF

GO TO TOP ▲

Copyright © 2013 FOR-A Company Limited. All rights reserved.

23-17-6. EXT IF - AUX UNIT

Click the **AUX UNIT** tab to display and set the AUX UNIT menu.

The screenshot shows the 'EXT I/F' menu with the 'AUX UNIT' tab selected. It displays two configuration blocks for 'AUX UNIT1' and 'AUX UNIT2'. Each block includes a dropdown for 'AUX SEL' (set to 'AUX1'), 'BRIGHTNESS HIGH' and 'LOW' input fields (set to 8 and 1), 'SHIFT' and 'TAKE' dropdowns (set to OFF), and a 'MAC ADDR' field. A 'GO TO TOP' button is located below each block.

Click a button to go to the desired menu block. See the operation manual main pages for details on each function.

AUX UNIT1
 AUX UNIT2
 AUX UNIT3
 AUX UNIT4
 AUX UNIT5

AUX UNIT1 ASSIGN
 AUX UNIT2 ASSIGN
 AUX UNIT3 ASSIGN
 AUX UNIT4 ASSIGN
 AUX UNIT5 ASSIGN

► See section 20-6. "AUX Bus Control Box (HVS-AUX16A/32A/64A)"

AUX UNIT1 ASSIGN								
BTN:	1	2	3	4	5	6	7	8
FUNC:	AUX XPT INPUT01	AUX XPT INPUT02	AUX XPT INPUT03	AUX XPT INPUT04	AUX XPT INPUT05	AUX XPT INPUT06	AUX XPT INPUT07	AUX XPT INPUT08
BTN:	9	10	11	12	13	14	15	16
FUNC:	AUX XPT STILL1	AUX XPT STILL2	AUX XPT STILL1 KEY	AUX XPT STILL2 KEY	AUX XPT COLORBA	AUX XPT MATTE1	AUX XPT MATTE2	AUX XPT CK FILL
BTN:	17	18	19	20	21	22	23	24
FUNC:	AUX XPT CK KEY	AUX XPT SUB EFFECT1	AUX XPT SUB EFFECT2	AUX XPT M/E1 PGM	AUX XPT M/E1 PREV	AUX XPT M/E1 CLEAN	AUX XPT M/E1 KEYOUT	AUX XPT MV1
BTN:	25	26	27	28	29	30	31	32
FUNC:	AUX1 TRANS ENABLE	AUX2 TRANS ENABLE	AUX3 TRANS ENABLE	AUX4 TRANS ENABLE	AUX5 TRANS ENABLE	AUX6 TRANS ENABLE	AUX7 TRANS ENABLE	AUX8 TRANS ENABLE
BTN:	33	34	35	36	37	38	39	40
FUNC:	(NOT ASSIGN)	(NOT ASSIGN)	(NOT ASSIGN)	(NOT ASSIGN)	(NOT ASSIGN)	(NOT ASSIGN)	(NOT ASSIGN)	(NOT ASSIGN)
BTN:	41	42	43	44	45	46	47	48
FUNC:	(NOT ASSIGN)	(NOT ASSIGN)	(NOT ASSIGN)	(NOT ASSIGN)	(NOT ASSIGN)	(NOT ASSIGN)	(NOT ASSIGN)	(NOT ASSIGN)

23-18. Pop-up Menu Operation

Holding down or hovering the mouse on the left edge of the GUI menu will bring up a pop-up menu as shown below. The pop-up menu allows you to display menu shortcuts, execute user buttons and set parameters to their default settings.

To close the pop-up menu, move the mouse or click on another area of the menu page.

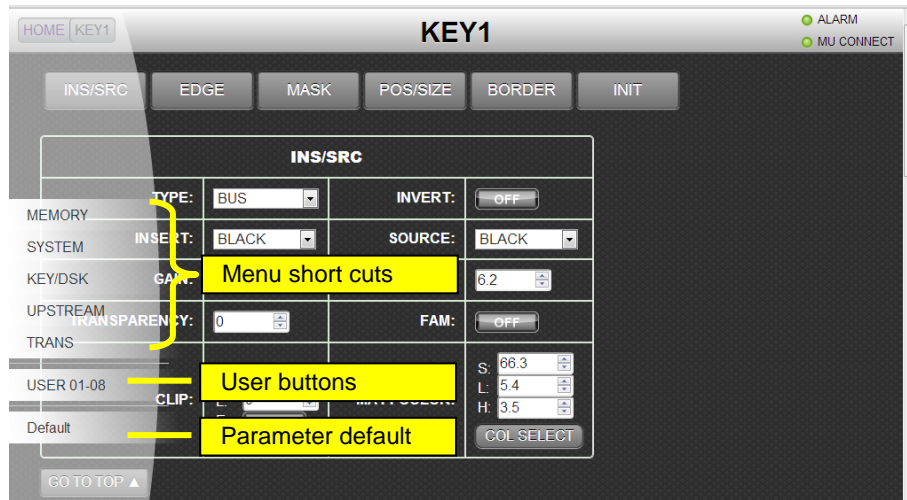

23-18-1. Menu Shortcuts

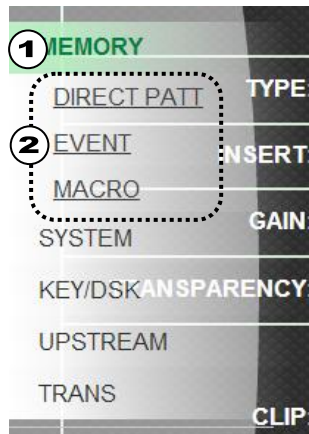

- (1) Click on a menu shortcut in the pop-up menu.
- (2) A detailed menu will appear. Click a menu name to display the menu page.

23-18-2. Executing User Buttons

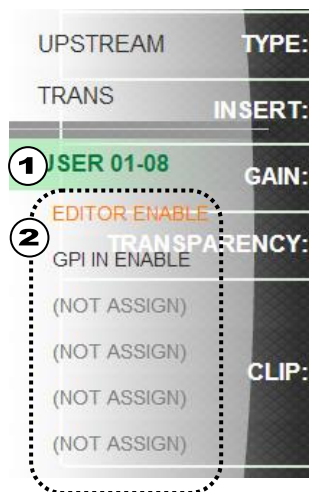

- (1) Click on **USER01-08** in the pop-up menu to display the user buttons and their functions, which were assigned under OU USER BUTTON.
- (2) Click a user button to execute its function.

Following functions are **unable** to be performed on the GUI.

TYPE	FUNC
MENU	FILE-SAVE
AUX	AUX5-8 XPT SELECT
VTR	VDPC REC
OTHER	JOY-STICK FINE

The following functions are available while the BUS TRANS menu is being displayed.

STILL	INPUT STILL STORE
OTHER	ROUTER ENABLE
	FS ENABLE
	MACRO BUS SELECT

23-18-3. Setting Parameters to Default

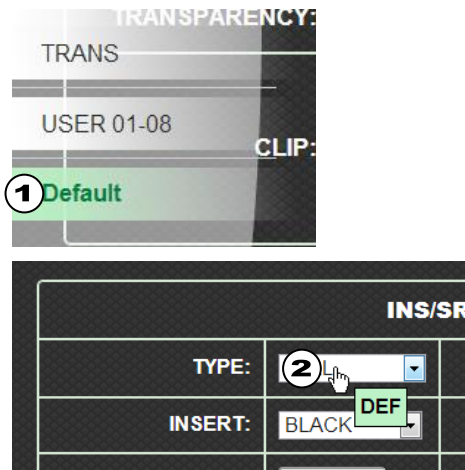

If menu parameters are able to be reset on the GUI, **Default** will be displayed at the bottom of the context menu.

To reset a parameter:

- (1) Click **Default** in the pop-up menu to change the mode to Default. "DEF" will be displayed as shown below.
- (2) Click on a parameter value (in a select box, text box or ON/OFF button) to reset the parameter.

To exit Default mode:

Click **Default** in the pop-up menu again.

23-19. Backing Up Settings

- ▶ See section 4-4. "How to Back up Settings"

Either of following two operations backs up panel settings and loads them automatically at startup. It is recommended to do either operation after changing menu settings.

- Rebooting (Rebooting the switcher instead of turning the power off then on.)

- ▶ See section 23-16-1. "SETUP - SYSTEM."

- Saving an event.

- ▶ See section 23-14 "EVENT."

When moving to another page after having changed any of the following menu settings, all menu data are automatically stored as a backup.

- All SETUP menu settings
- All EXT I/F menu settings
- Overwrite-protection for each event, and direct pattern.
- Each macro overwrite-protection and file name.

24. Specifications and Dimensions

24-1. Specifications

24-1-1. HVS-XT100

Video Formats	1080/59.94i, 1080/50i, 1080/24PsF, 1080/23.98PsF, 1080/25PsF, 1080/29.97PsF, 720/59.94p,720/50p 525/60 (NTSC), 625/50 (PAL)
HVS-100EXP3G	1080/59.94p, 1080/50p (3G-SDI Level-A)
Video Input	HD-SDI: 1.5 Gbps or SD-SDI: 270 Mbps 75Ω BNC x 8
Video Input (option)	Max. 2 cards. (Max. 3 cards including input/output cards.)
HVS-100EXP3G	3G-SDI: 1.5 Gbps
HVS-XT100DI-A	HD-SDI: 1.5Gbps or SD-SDI: 270Mbps 4 inputs or 2 inputs BNC
HVS-XT100AI	HD/SD analog component or analog composite 1.0 Vp-p 2 inputs BNC
HVS-XT100PCI (RGB)	1080i: XGA to WUXGA 720p: XGA to WXGA SD: VGA to XGA 2 inputs (HDCP not compatible) HDMI (type A), VGA
Number of Video Inputs	Standard: 8 (SDI x 8) Max.: 14 (SDI x 14) or (SDI x 12 and Analog/RGB x 2)
Video Output	HD-SDI: 1.5 Gbps or SD-SDI: 270 Mbps 75Ω BNC x 4 (AUX1-AUX4. Crossfade switching available) HDMI: HDTV (1080i, 720p) SDTV (SD) (HDCP not compatible) HDMI (type A) x 1
Video Output (option)	Max. 2 cards. (Max. 3 cards including input/output cards.)
HVS-100EXP3G	3G-SDI: 1.5 Gbps
HVS-XT100DO	HD-SDI: 1.5Gbps or SD-SDI: 270Mbps 2 outputs BNC
HVS-XT100AO	HD/SD analog component or analog composite 1.0 Vp-p 2 outputs BNC
HVS-XT100PCO (HDMI: RGB)	2 outputs (HDCP not compatible), HDMI (type A), VGA 1080i: SXGA to WUXGA, HDTV 720p: SXGA, WXGA, HDTV SD : SVGA, SDTV
(VGA)	1080i: SXGA to WUXGA (RGB), HDTV (YPbPr) 720p: SXGA, WXGA (RGB), HDTV (YPbPr) SD : SVGA (RGB)
Number of Video Outputs	Standard: 5 (SDI x 4, HDMI x1) Max.: 9 (SDI x 4, HDMI x1, SDI/Analog/RGB x 4)
Genlock Input	BB: NTSC: 0.429 Vp-p/PAL: 0.45Vp-p or Tri-level Sync: 0.6 Vp-p 75Ω BNC x 1, loop-through (Terminate with 75Ω terminator, if unused.)
System Phase Adjust	Horizontal: -1/2H to +1/2H
Genlock Output	BB: NTSC: 0.429 Vp-p/PAL: 0.45Vp-p or Tri-level Sync: 0.6 Vp-p 75Ω BNC x 1
Signal Processing	4:2:2 Digital component
Quantization	HD/SD-SDI: 10-bit
FS / Process Amp	Frame Synchronizer and Process Amp features on each input

Effect		
Pattern	WIPE	100 patterns, Border and Softness
	2D DVE	36 patterns
Sub-effect channel		x 2 (SBEF1 and SBEF2) available on inputs
Transition		Execution: Fader lever, AUTO or CUT button Type: MIX or WIPE (DVE included)
Still/Clip Memory		2 still buffers with backup feature 2 clip buffers, Recording capacity: 7.5 seconds (HD video)for each
Key		
KEY/DSK		x 4 (KEY x 2 and DSK x 2) Luminance, Full or Bus key, KEY1, KEY2: Edge/shadow effects DSK1, DSK2: Direct display on AUX outputs possible
Chroma key channel		x 1 (used for switcher source / direct output)
DVE channel		x 4 (2D) Available on BKGD, KEY and DSK
Multiviewer channel		x 1 with 2/4/5/7/9/10/11/16-way split views Display: Title, Tally, Audio Level Meter, Safety Area and Frame Border Layout backup: Up to 8 patterns 1 frame delay relative to PGM output
Event Memory		100 events
I/O Delay		Minimum delay: HD: 1H, SD: 1H If FS or Up-resize engine used: 1-2 frames + Minimum delay If FS or Up-resize engine plus DVE used: 2-3 frames + Minimum delay FS or Up-resize engine plus Output resize engine and DVE used: 3-4 frames + Minimum delay
Interfaces		
TO OU		For HVS-XT100OU connectin, RJ-45 x 1
LAN		100Base-TX/100BASE-T RJ-45 x 1
GPI IN/TALLY OUT		25-pin D-sub (female) x 1 (inch screw) 24-input/output (GPI input/output and tally output programmable) Open collector or no-voltage contact input, open collector output
RS-422		9-pin D-sub (female) x 6 (with inch screws) * For HVS-30RU, VTR, router and tally unit connection
USB MEMORY (Front side)		For USB flash drive connection, USB1.1, Type A connector x 1
Temperature		0°C to 40°C
Humidity		30% to 90% (no condensation)
Power		100VAC to 240 VAC ±10%, 50/60Hz
Consumption		Standard: 106 W (at 100-120 VAC), 97 W (at 220-240 VAC) Full Option: 207 W (at 100-120 VAC), 198 W (at 220-240 VAC)
Dimensions		430 (W) x 225 (D) x 88 (H) mm
Weight		5.3 kg (in Standard), 6.9 kg (in Full Option)
Consumables		Power supply unit: Replace every 5 years. HVS-XT100PSM: Replace every 5 years. Cooling fan: Replace every 4 years

24-1-2. HVS-XT100OU

Interfaces	
TO MU (LAN)	For HVS-XT100 connectin, RJ-45 x 1
Temperature	0°C to 40°C
Humidity	30% to 90% (no condensation)
Power	100VAC to 240 VAC ±10%, 50/60Hz DC 12V (Supplied from the AC adapter)
Consumption	13W (at 100-120V AC) 14W (at 100-120V AC)
Dimensions	420 (W) x 246 (D) x 87.2 (H) mm
Weight	2.6 kg
Consumables	Power supply unit: Replace every 5 years. HVS-XT100PSO: Replace every 5 years.

24-1-3. HVS-XT110

Video Formats	1080/59.94i, 1080/50i, 1080/24PsF, 1080/23.98PsF, 1080/25PsF, 1080/29.97PsF, 720/59.94p, 720/50p 525/60 (NTSC), 625/50 (PAL)	
HVS-100EXP3G	1080/59.94p, 1080/50p (3G-SDI Level-A)	
Video Input	HD-SDI: 1.5 Gbps or SD-SDI: 270 Mbps 75Ω BNC x 12	
HVS-100EXP3G	3G-SDI: 1.5 Gbps	
Video Output	HD-SDI: 1.5 Gbps or SD-SDI: 270 Mbps 75Ω BNC x 8 (AUX1-AUX8. Crossface switching available)	
HVS-100EXP3G	3G-SDI: 1.5 Gbps	
	HDMI:	HDTV (1080i, 720p) SDTV (SD) HDCP unsupported HDMI type A connector x 1
Genlock Input	BB: NTSC: 0.429 Vp-p/PAL: 0.45Vp-p or Tri-level Sync: 0.6 Vp-p 75Ω BNC x 1, loop-through (Terminate with 75Ω terminator, if unused.)	
System Phase Adjust	Horizontal: -1/2H to +1/2H	
Genlock Output	BB: NTSC: 0.429 Vp-p/PAL: 0.45Vp-p or Tri-level Sync: 0.6 Vp-p 75Ω BNC x 1	
Signal Processing	4:2:2 Digital component	
Quantization	HD/SD-SDI: 10-bit	
FS / Process Amp	Frame Synchronizer feature on INPUT01-08 Process Amp feature on each input	
Effect		
Pattern	WIPE	100 patterns, Border and Softness
	2D DVE	36 patterns
Sub-effect channel	x 2 (SBEF1 and SBEF2) available on inputs	
Transition	Execution: Fader lever, AUTO or CUT button Type: MIX or WIPE (DVE included)	
Still/Clip Memory	2 still buffers with backup feature 2 clip buffers, Recording capacity: 7.5 seconds (HD video)for each	
Key		
KEY/DSK	x 4 (KEY x 2 and DSK x 2) Luminance, Full or Bus key, KEY1, KEY2: Edge/shadow effects DSK1, DSK2: Direct display on AUX outputs possible	
Chroma key channel	x 1 (used for switcher source / direct output)	
DVE channel	x 4 (2D) Available on BKGD, KEY and DSK	
Multiviewer channel	x 1 with 2/4/5/7/9/10/11/16-way split views Display: Title, Tally, Audio Level Meter, Safety Area and Frame Border Layout backup: Up to 8 patterns 1 frame delay relative to PGM output	
Event Memory	100 events	
I/O Delay	Minimum delay:	HD: 1H, SD: 1H
	If FS or Up-resize engine used:	1-2 frames + Minimum delay
	If FS or Up-resize engine plus DVE used:	2-3 frames + Minimum delay
	FS or Up-resize engine plus Output resize engine and DVE used:	3-4 frames + Minimum delay

Interfaces	
LAN	100Base-TX/1000BASE-T RJ-45 x 1
GPI IN/TALLY OUT	25-pin D-sub (female) x 1 (inch screw) 24-input/output (GPI input/output and tally output programmable) Open collector or no-voltage contact input, open collector output
RS-422	9-pin D-sub (female) x 2 (with inch screws) * For HVS-30RU, VTR, router, tally unit and editor connection
USB MEMORY (Front side)	For USB flash drive connection, USB1.1, Type A connector x 1
Temperature	0°C to 40°C
Humidity	30% to 90% (no condensation)
Power	100VAC to 240 VAC \pm 10%, 50/60Hz DC 12V / 16 A (Supplied from the AC adapter)
Consumption	100 W (at 100-120 VAC) 99 W (at 220-240 VAC)
Dimensions	420 (W) x 246 (D) x 129.3 (H) mm
Weight	2.6 kg
Consumables	Power supply unit: Replace every 5 years. HVS-XT110PSM: Replace every 5 years. Cooling fan: Replace every 4 years

24-2. External Dimensions

24-2-1. HVS-XT100

(All dimensions in mm)

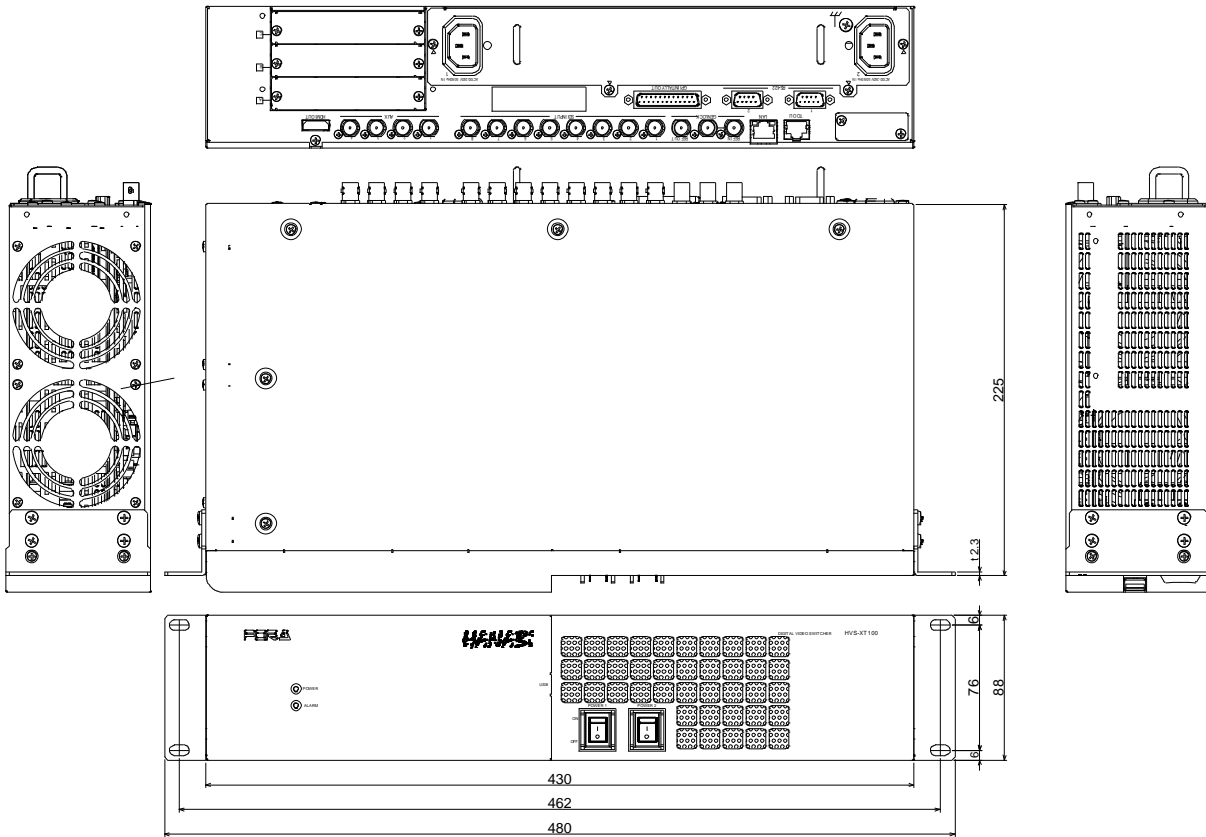

24-2-3. HVS-XT110

(All dimensions in mm)

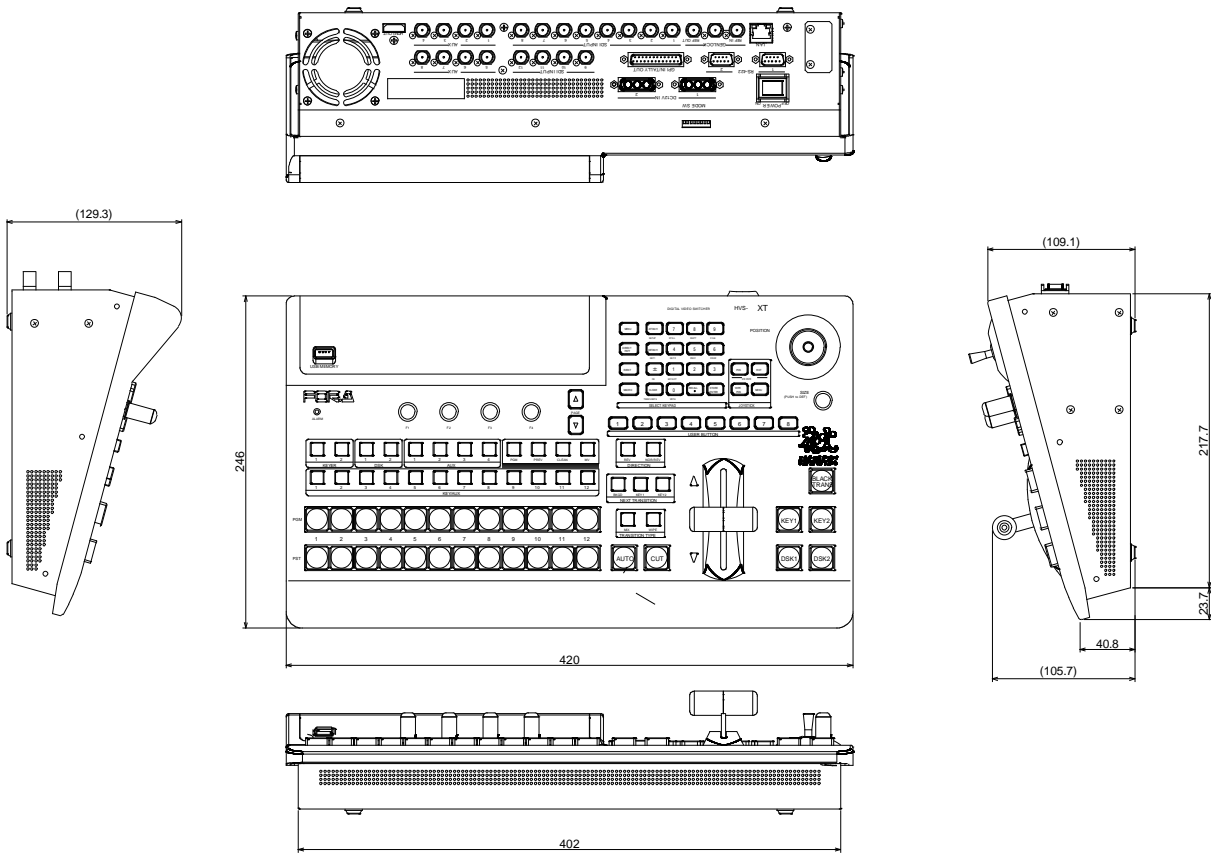

Appendix 1. Supported File Types

Menu Setting Files and Image Files (via USB flash drive or Ethernet connection)

File Extension	File Type (*1)	Data Description
all	DATA.all	System settings and all wipe, event and macro data
sys	HVSXT100.sys	System settings
mem	EVENT.mem	All event memory data
mcr	MACRO.mcr	All macro data
jpg (*2)	*.jpg	JPEG images (standard RGB) JPEG sequential images
	STILL1.jpg to STILL2.jpg	Stored still images in JPEG format
tga (*2)	*.tga	8-, 24- and 32-bit TARGA images (uncompressed RGB and RLE encoded) TARGA sequential images
	STILL1.tga to STILL2.tga	Stored still images in TARGA format
bmp (*2)	*.bmp	24-bit BITMAP images (uncompressed RGB) BITMAP sequential images
	STILL1.bmp to STILL2.bmp	Stored still images in BITMAP format

Note that file names are limited to max. 16 characters in length (ASCII code).

(*1) Files are automatically saved in their correct format as shown in the table above when saving to USB flash drive.

(*2) When loading a jpeg, targa or bitmap file from USB flash drive, you can select a centered or tiled format as well as a normal one. In such case, a centered or tiled format image file is saved to STILL as a jpg, tga or bmp file.

Factory Tested USB Flash Drives

Manufacturer	Series Name	Model Name
SanDisk	Cruzer micro, Cruzer mini Series	SDCZ2-256
I/O DATA	TB-ST Series	ToteBag
Transcend	JetFlash150 Series	
TOSHIBA	TransMemory Series	U2B-256MT

Appendix 2. Transition Pattern List

◆ WIPE Type

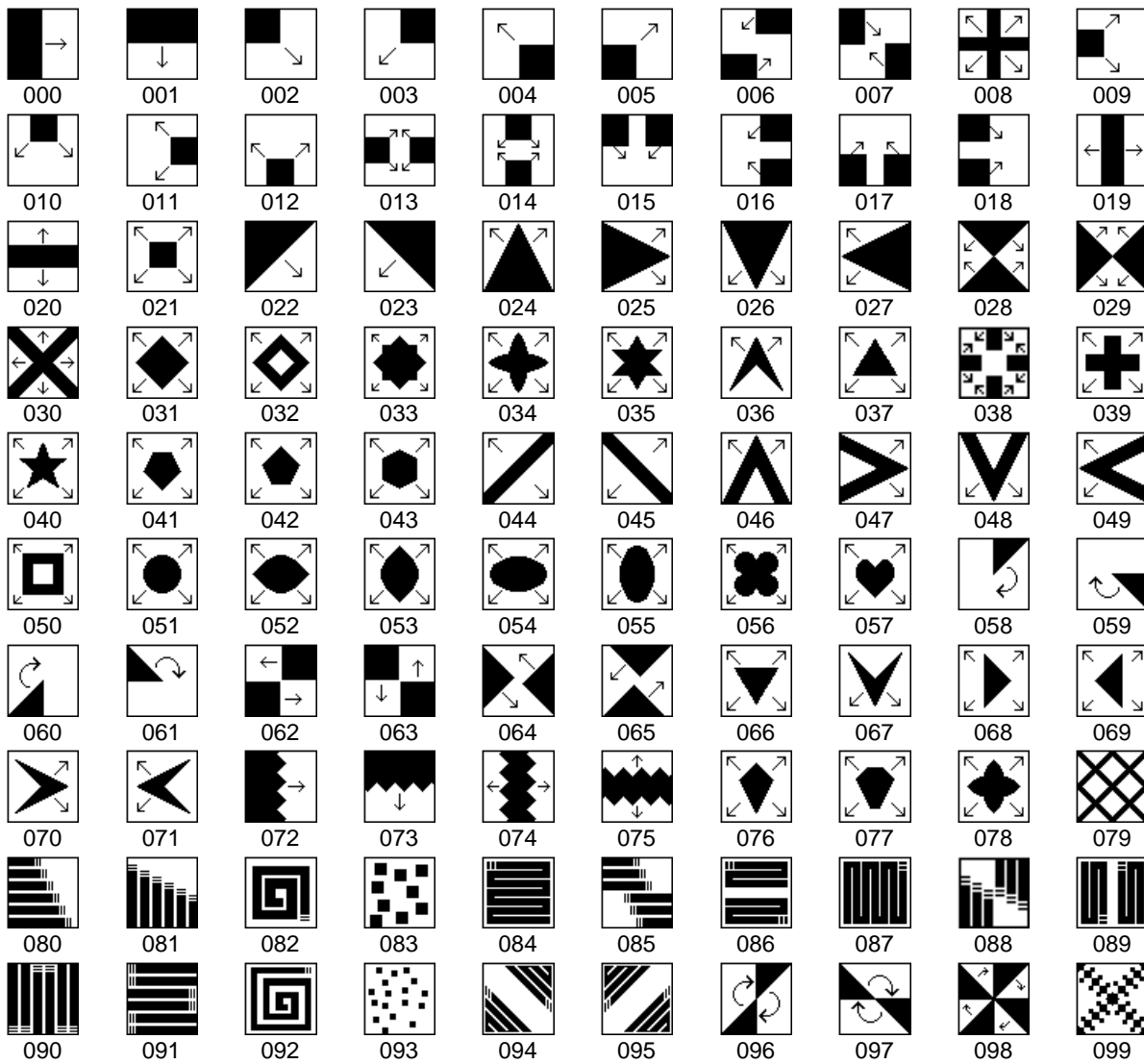

◆ DVE type

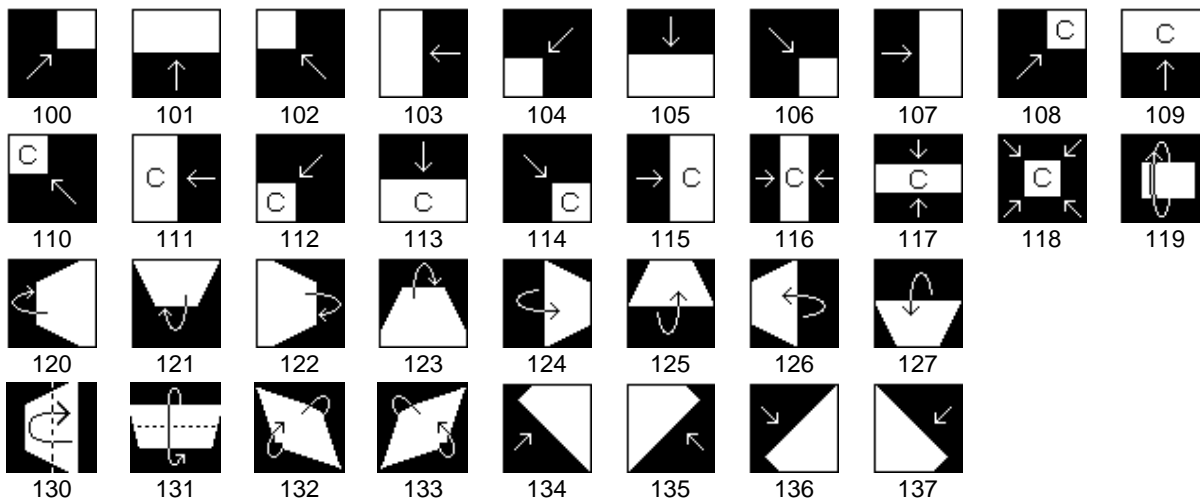

Index

- 2**
 - 2D-DVE effect..... 98
- 3**
 - 3G-SDI 210
- 4**
 - 4K mode 210
- A**
 - AC cord clamp 24
 - additional output channels 56
 - additional outputs 56, 60
 - Alarm status 168
 - Ancillary data 62
 - Arcnet 201
 - Arcnet 201
 - Aspect ratio 100
 - Audio level meter 136
 - AUX Box 201, 202
 - AUX bus control boxes 201, 202
 - AUX link 63
 - AUX video 52
 - Available files 159
 - Available image files 126
- B**
 - Back up settings 37
 - Background transitions 71
 - Black transition 76
 - Brightness 167
 - Bus buttons 39, 51
 - Bus key 91, 92
 - Bus matte 45
 - Bus operation 65
 - Buzzer 167
- C**
 - CG WIPE 130
 - Chromakey 105
 - Clean 54
 - Clip (Key) 94
 - Clip memory 129
 - Clip stores 118
 - Connection 23
 - Control panel 16, 20
 - Cooling fan 21
 - Crop 103
 - CUT transition 71, 73
- D**
 - Date 30, 165
 - Default 37
 - Default setting 149
 - Defocus 114
 - Delay 42
 - Direct Button 209
 - Direct Pattern 79
 - DSK images 75
 - DSK Transition 75
 - DVE effects 78, 98
 - DVE operation 89
- E**
 - Editor control 199
 - Ethernet 126
 - Event memory 145
 - External dimensions 258
- F**
 - F1 to F4 34
 - Factory default 37, 149
 - FADE 100
 - Fan alarm 16, 17, 20
 - File operation 159
 - Frame border 137
 - Frame synchronizer 43
 - Freeze 115
 - Front panel 17
 - Front Panel 17
 - Full key 90, 92
- G**
 - Gain (Key) 94
 - GPI IN/TALLY OUT 22, 174
 - Gradient matte 45
- H**
 - HDMI output 55
 - HVS-30RU 206
 - HVS-XT100 17, 253, 258
 - HVS-XT100 / XT100OU 23
 - HVS-XT100/XT100OU 28
 - HVS-XT100ARC 201
 - HVS-XT100ED 199
 - HVS-XT100EXP3G 210
 - HVS-XT100OU 16, 255, 259
 - HVS-XT110 20, 28, 260
- I**
 - Image files 261
 - Initialization 173
 - INPUT STILL 41
 - Inside border 104
 - Installed option 169
 - Interface 22
 - Invert (Key) 95
 - IP address 208
- J**
 - Joystick 36
- K**
 - Key edge 97
 - KEY INSERT MATT 93
 - Key link 93
 - KEY OUT 54
 - KEY transition 73
 - KEY/AUX 32
 - KEY/AUX bus 51
 - KEY/DSK 90
 - KEY/DSK transition 86
 - Keypad 35
 - Keypad block 31

L	
LAN settings	125
Layer order	94
Luminance key	90, 91
M	
Macro	209
Macro attach	158
Macro detach	158
Macros	152
Mask (Key)	95
Matte color	45
Menu access button	31
Menu navigation	33
Menu operation	31
Menu setting files	261
Menus to default	37
MFR link	192
MIX transition	71, 73, 75
Modifying patterns	82
Mono color	114
Mosaic	115
Multiviewer	133
N	
Name	38, 47
Negative	115
Next video	72
O	
On-air tally	137
Option Slots	19
Outside border	104
P	
P/P (PGM/PST)	67
Page navigation	34
Paint color	115
Parameters to default	37
Pattern transition	73, 77
PGM/PST	32, 65
Playing clips	120
Power ON	28
Preview	53
Proc amp	44
R	
Rear panel	17, 18, 21
Rebooting system	173
Recording video	118
Reference signal	165
Resize function	40
Rotation	101
RS-422 connector	22
RS-422 port settings (VTR/VDCP)	183
S	
Safety area	61, 136
Screen saver	167
sequential image files	129
Set values	33
SHIFT	68
Side panel	42
Signal format	29, 164
simultaneous transition	76
SmartDirect	208
SNTP Time server	166
Specifications	253
Status information	168
Still image	116, 128
Stills	125
Strobe	115
SUB EFFECT	114
Switch timing	164
System setup	164
T	
Time	30, 165
Time zone	30, 165
Transition	69
Transition block	32, 70
Transition limit	81, 89
Transition rate	81, 88, 150
U	
Upgrade procedure	171
USB flash drive	159, 261
USER button	32
USER buttons	139
USER transition	75, 87
USER Transition	74
V	
Version	169
Video clips	125
Video level clip	44
Video outputs	51
Video source	38, 65
VTR / VDCP control	183
W	
WIPE transition	71
X	
XPT delay	42

Warning

This equipment has been tested and found to comply with the limits for a Class A digital device, pursuant to Part 15 of FCC Rules. These limits are designed to provide reasonable protection against harmful interference when the equipment is operated in a commercial environment. This equipment generates, uses, and can radiate radio frequency energy and, if not installed and used in accordance with the instruction manual, may cause harmful interference to radio communications. Operation of this equipment in a residential area is likely to cause harmful interference, in which case the user will be required to correct the interference at his own expense.



FOR-A COMPANY LIMITED

Head Office 3-8-1 Ebisu, Shibuya-ku, Tokyo 150-0013, Japan
Overseas Division Phone: +81(0)3-3446-3936, Fax: +81(0)3-3446-1470
Japan Branch Offices Osaka/Okinawa/Fukuoka/Hiroshima/Nagoya/Sendai/Sapporo
R&D/Production Sakura Center/Sapporo Center

FOR-A America Corporate Office

11155 Knott Ave., Suite G&H, Cypress, CA 90630, USA
Phone: +1-714-894-3311 Fax: +1-714-894-5399

FOR-A America East Coast Office

2 Executive Drive, Suite 670, Fort Lee Executive Park, Fort Lee, NJ 07024, USA
Phone: +1-201-944-1120 Fax : +1-201-944-1132

FOR-A America Distribution & Service Center

2400 N.E. Waldo Road, Gainesville, FL 32609, USA
Phone: +1-352-371-1505 Fax: +1-352-378-5320

FOR-A Corporation of Canada

346A Queen Street West, Toronto, Ontario M5V 2A2, Canada
Phone: +1-416-977-0343 Fax: +1-416-977-0657

FOR-A Latin America & the Caribbean

5200 Blue Lagoon Drive, Suite 760, Miami, FL 33126, USA
Phone: +1-305-931-1700 Fax: +1-305-264-7890

FOR-A Europe S.r.l.

Via Volturmo 37, 20861 Brugherio MB, Italy
Phone: +39-039-879-778 Fax:+39-039-878-140

FOR A UK Limited

Trident Court, 1 Oakcroft Road, Chessington, KT9 1BD, United Kingdom
Phone: +44 (0)20-3044-2935 Fax: +44(0)20-3044-2936

FOR-A Italia S.r.l.

Via Volturmo 37, 20861 Brugherio MB, Italy
Phone: +39-039-881-086/103 Fax: +39-039-878-140

FOR-A Corporation of Korea

1007, 57-5, Yongsan-ro, Yeongdeungpo-gu, Seoul 150-103, Korea
Phone: +82(0)2-2637-0761 Fax: +82(0)2-2637-0760

FOR-A China Limited

708B Huateng Bldg., No. 302, 3 District, Jinsong, Chaoyang, Beijing 100021, China
Phone: +86(0)10-8721-6023 Fax: +86(0)10-8721-6033

FOR-A Middle East-Africa Office

Jebel Ali Free Zone, LOB-16, Office 619, P. O. Box: 261914 Dubai, UAE
Phone: +971 4 887 6712 Fax: +971 4 887 6713