

Digital Video Switcher

SE-2000



INSTRUCTION MANUAL

www.datavideo-tek.com

Contents

Warnings and Precautions	4
Warranty	5
<i>Standard Warranty</i>	5
<i>Two Year Warranty</i>	5
<i>Disposal</i>	5
<i>Packing List</i>	5
Introduction	6
<i>Product Overview</i>	6
<i>Features</i>	6
Connections & Controls	7
<i>Keyboard</i>	7
Audio mixer.....	8
Audio Input Source Selectors and Level Controls.....	8
Audio LED Meters.....	8
Audio Monitor Button.....	8
System Configuration Menu.....	9
Logo Setting.....	9
PIP / KEY.....	9
Transition Effects.....	9
Transition Speed.....	9
CUT.....	9
TAKE.....	9
T-Bar.....	10
Main Source.....	10
Sub Source.....	10
Headphone.....	10
Headphone Volume Control.....	10
<i>Rear Panel</i>	11
Rear Panel Connections.....	11
Multi Preview Output	13
<i>Main Source and Sub Source Rails</i>	14
<i>Transition Effects</i>	14
System Configuration Menu	15
<i>Menu and Navigation</i>	15
USER'S PROFILE.....	15
INPUT SETTINGS.....	15
PIP SETTING.....	16
LUMA SETTING.....	16
LOGOS.....	16
MODE SETTING.....	17
MONITOR MODE.....	17
INPUT 4 MODE.....	17
MASTER USER SETTING.....	17
SOFT EDGE.....	17
AUTO TAKE SPEED.....	17
BACKGROUND.....	18

BLACK & BARS POS.RIGHT.....	18
FACTORY SETTINGS	18
CLOCK SETTINGS	18
MAX BUTTON BRIGHTNESS	18
TWO WAY T-BAR MODE	18
Audio Inputs and Levels.....	19
A+V.....	19
Example SE-2000 Set Ups	20
SE-2000 Configuration Utility.....	21
<i>Storing New Logos</i>	<i>21</i>
<i>How to change the input source labels</i>	<i>22</i>
Setting up a Luma Key overlay with PowerPoint.....	23
HD-SDI Cabling Advice	24
How to update SE-2000 firmware	25
SE-2000 bespoke Tally cabling advice.....	27
SE-2000 RS-232 Remote Control Protocol	28
<i>Communication diagram.....</i>	<i>28</i>
<i>Control Interface</i>	<i>28</i>
<i>Pin Assignment.....</i>	<i>28</i>
<i>Command Code Format.....</i>	<i>28</i>
<i>Response Code Format</i>	<i>28</i>
<i>CRC (CRCL,CRCH)</i>	<i>29</i>
<i>Table 1. Lower CRC byte calculation coefficients.(Hex)</i>	<i>31</i>
<i>Table 2. Higher CRC byte calculation coefficients.(Hex).....</i>	<i>32</i>
<i>Table 3. Command Type.....</i>	<i>33</i>
<i>Table 4. Response Code.....</i>	<i>34</i>
<i>Table 5. Status Code (41 Bytes reference pages 35 & 37).....</i>	<i>35</i>
Optional Datavideo Accessory Items for the SE-2000	38
Specifications	39
Service and Support	40

Disclaimer of Product and Services

The information offered in this instruction manual is intended as a guide only. At all times, Datavideo Technologies will try to give correct, complete and suitable information. However, Datavideo Technologies cannot exclude that some information in this manual, from time to time, may not be correct or may be incomplete. This manual may contain typing errors, omissions or incorrect information. Datavideo Technologies always recommend that you double check the information in this document for accuracy before making any purchase decision or using the product. Datavideo Technologies is not responsible for any omissions or errors, or for any subsequent loss or damage caused by using the information contained within this manual. Further advice on the content of this manual or on the product can be obtained by contacting your local Datavideo Office or dealer.



Warnings and Precautions

1. Read all of these warnings and save them for later reference.
2. Follow all warnings and instructions marked on this unit.
3. Unplug this unit from the wall outlet before cleaning. Do not use liquid or aerosol cleaners. Use a damp cloth for cleaning.
4. Do not use this unit in or near water.
5. Do not place this unit on an unstable cart, stand, or table. The unit may fall, causing serious damage.
6. Slots and openings on the cabinet top, back, and bottom are provided for ventilation. To ensure safe and reliable operation of this unit, and to protect it from overheating, do not block or cover these openings. Do not place this unit on a bed, sofa, rug, or similar surface, as the ventilation openings on the bottom of the cabinet will be blocked. This unit should never be placed near or over a heat register or radiator. This unit should not be placed in a built-in installation unless proper ventilation is provided.
7. This product should only be operated from the type of power source indicated on the marking label of the AC adapter. If you are not sure of the type of power available, consult your Datavideo dealer or your local power company.
8. Do not allow anything to rest on the power cord. Do not locate this unit where the power cord will be walked on, rolled over, or otherwise stressed.
9. If an extension cord must be used with this unit, make sure that the total of the ampere ratings on the products plugged into the extension cord do not exceed the extension cord's rating.
10. Make sure that the total amperes of all the units that are plugged into a single wall outlet do not exceed 15 amperes.
11. Never push objects of any kind into this unit through the cabinet ventilation slots, as they may touch dangerous voltage points or short out parts that could result in risk of fire or electric shock. Never spill liquid of any kind onto or into this unit.
12. Except as specifically explained elsewhere in this manual, do not attempt to service this product yourself. Opening or removing covers that are marked "Do Not Remove" may expose you to dangerous voltage points or other risks, and will void your warranty. Refer all service issues to qualified service personnel.
13. Unplug this product from the wall outlet and refer to qualified service personnel under the following conditions:
 - a. When the power cord is damaged or frayed;
 - b. When liquid has spilled into the unit;
 - c. When the product has been exposed to rain or water;
 - d. When the product does not operate normally under normal operating conditions. Adjust only those controls that are covered by the operating instructions in this manual; improper adjustment of other controls may result in damage to the unit and may often require extensive work by a qualified technician to restore the unit to normal operation;
 - e. When the product has been dropped or the cabinet has been damaged;
 - f. When the product exhibits a distinct change in performance, indicating a need for service.

We recommend that you only use the SE-2000 Configuration Utility to add/write new Logos as changing any other settings without guidance may cause the mixer or its set up menus to become un-usable. See Page 19.

Warranty

Standard Warranty

- Datavideo equipment is guaranteed against any manufacturing defects for one year from the date of purchase.
- The original purchase invoice or other documentary evidence should be supplied at the time of any request for repair under warranty.
- Damage caused by accident, misuse, unauthorized repairs, sand, grit or water is not covered by this warranty.
- All mail or transportation costs including insurance are at the expense of the owner.
- All other claims of any nature are not covered.
- Cables & batteries are not covered under warranty.
- Warranty only valid within the country or region of purchase.
- Your statutory rights are not affected.

Two Year Warranty

- All Datavideo products purchased after 01-Oct.-2008 qualify for a free one year extension to the standard Warranty, providing the product is registered with Datavideo within 30 days of purchase. For information on how to register please visit www.datavideo-tek.com or contact your local Datavideo office or authorized Distributors
- Certain parts with limited lifetime expectancy such as LCD Panels, DVD Drives, Hard Drives are only covered for the first 10,000 hours, or 1 year (whichever comes first).
- Any second year warranty claims must be made to your local Datavideo office or one of its authorized Distributors before the extended warranty expires.

Disposal



For EU Customers only - WEEE Marking

This symbol on the product indicates that it should not be treated as household waste. It must be handed over to the applicable take-back scheme for the recycling of Waste Electrical and Electronic Equipment. For more detailed information about the recycling of this product, please contact your local Datavideo office.

Packing List

Items	Description	Q'ty
1	SE-2000	1
2	AC Power Cord	1
3	AC/DC Switching Adaptor 12V DC 5A	1
4	SE-2000 Instruction Manual	1

Introduction

Thank you for purchasing the Datavideo SE-2000 Digital Video Switcher. We hope you will be pleased with your purchase, and with what you can achieve with this switcher. In order to get the most out of your new switcher, we recommend that you spend some time getting familiar with this manual, as it will describe all the functions of this unit. In addition, you'll find some useful background information on video and audio.

Product Overview

The Datavideo SE-2000 is a rugged and very portable five channel full HD video & audio switcher designed to excel in a new demanding high-definition production environment.

The brand new SE-2000 switcher not only meets your request for true full 1920 x 1080 HD quality, but also provides an array of simple-to-operate features, including up to 14 pre-stored logos, digital clock display, five user setup, DVI-D connection for use with presentation software and easy titling, and many more features.

Whether you're working in worship, education or conducting a live outside broadcast or shooting inside a production studio, the Datavideo SE-2000 full HD video and audio switcher enables you to switch seamlessly between video and audio sources and blend high-quality digital content on the fly, even without external genlock, thanks to the built in TBC.

Features

- **FULL HD:**

- Input:**

- 4x HD-SDI with 1x DVI-D input (Optional - See page 18 for example set up)
 - Or
 - 3x HD-SDI, with 2x DVI-D inputs (Optional - See page 18 for example set up)

- Output:**

- PGM: Full HD output, HD-SDI and HD-YUV format
 - PVW: DVI-D

- Multi Image Preview output with Digital Clock, selected Transition and User profile display.
- DVI-D for Power point presentation, simple titling and overlays, also supports full HD input.
- LOGO and CLOCK insertion. Display 2 Logos or a Logo and the Clock on the PVW and PGM outputs.
- Store and select from 14 user created Logos (accepted size 256x192 pixels, TGA or BMP)
- 4 channel input audio mixer with XLR in/out connectors.
- A+V Audio follows Video switching operation.
- Single or Two Way T-BAR operation via menu option
- LUMA Key
- PIP, FRZ, Black image
- 5 individual Speed keys for instant selection with TAKE effect
- 13 Transition effects (12 WIPE & 1 MIX) with soft (SFT) border option
- Memory presets for up to 5 users or configurations
- Tally output
- RS-232 control
- DC 12V 5A input

Connections & Controls

Keyboard

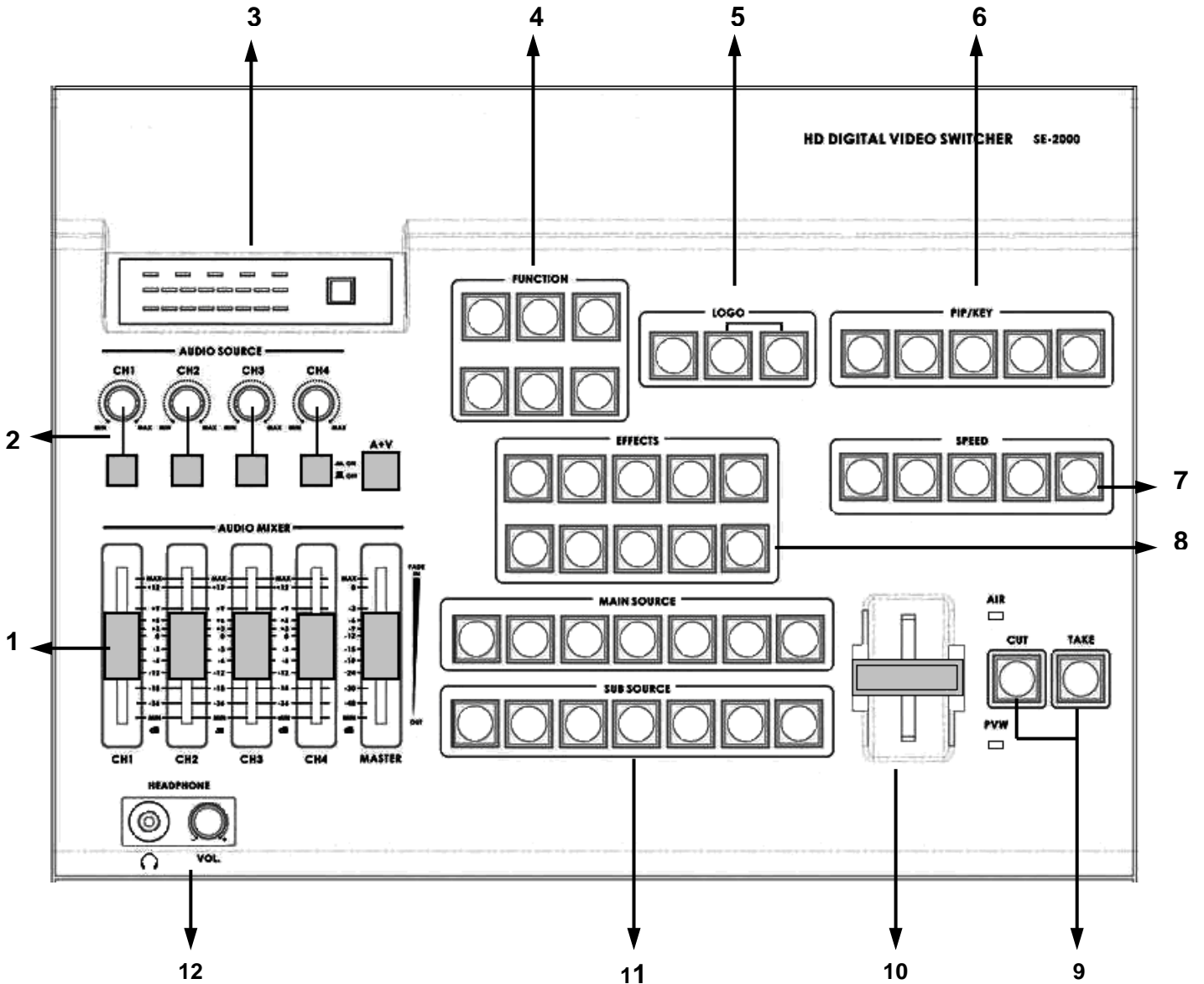

- | | |
|---|---|
| 1. Audio mixer | 7. Transition Speed |
| 2. Audio input selectors / Level Controls | 8. Transition Effects |
| 3. Audio meters | 9. CUT & TAKE |
| 4. Menu and Controls | 10. T-Bar |
| 5. Logo & Clock Selection | 11. Main and Sub Source selection |
| 6. Video Effect: PIP / KEY | 12. Headphone Monitoring & Volume Control |

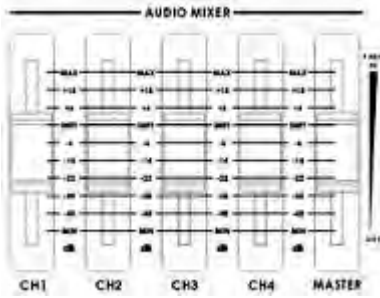

Audio mixer

These CH1~CH4 Audio Level Faders are for controlling the CH1~CH4 audio mix.

These faders correspond to the Audio Source selector buttons and control the relative volume of each input in the master output as well as the master output level. They are called faders because they are used to decrease (rather than increase) the signal levels to create a balanced and pleasing mix. When the CH1~CH4 Audio Level Faders are set at -6dB, or Unity, they pass the audio signal through at the same level as when it entered the bus. This is why the level setting at the Input Bus is so important.

MASTER: This Slider is for controlling the audio level for the Mixed audio output.

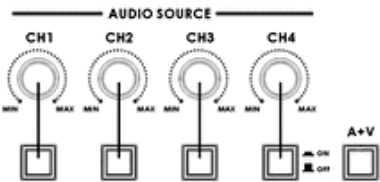

Audio Input Source Selectors and Level Controls

This section of the SE-2000 controls which audio input channel (CH1~CH4) will be sent to the Audio Bus and its associated Fader.

This row of audio channel selection buttons has LEDs built in to show which input channel is active. Level control for each audio input source is via the rotary pots above each of the audio channel selection buttons.

A+V:

When this button is engaged or lit, the audio associated with a selected video input source automatically follows the video through any transition between the Main and Sub Sources. When the A+V button is inactive, the audio sources must be switched manually. For more information, see **A+V** (*Page 17*).



Audio LED Meters

These meters play a vital part in correctly setting the audio levels to avoid clipping or other distortion.

The LED style Audio meters, show the signal strength at the Audio Output. The signal they measure is determined by the sources selected by the Audio Bus selectors and the levels set by the rotary pots and faders.

Audio Monitor Button

Use the Headphone section to monitor any of the sources (CH1, CH 2, CH3, CH4) or "Master" output. Repeated presses of the Headphone Audio Monitor button will cycle through the monitoring choices. In many cases, headphones may be a more useful and accurate choice than speakers for audio monitoring.

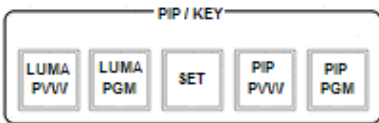
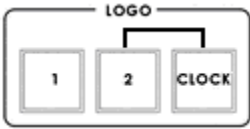
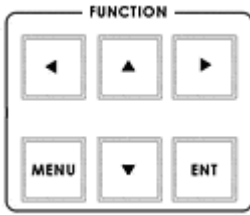

System Configuration Menu

Press the **Menu** button in the SE-2000 function section to enter the *System Configuration Menu*. Press the **up**, **down**, **left**, and **right** arrow buttons to navigate the menu options and to change values. Use the **ENT** button to save and confirm any setting that has been amended.

Logo Setting

Press the Logo1, Logo2 or Clock buttons to display the selected function on the PVW and PGM screens. See **Storing New Logos (Page 19)**

Logo1 and Logo2 or Logo1 and the Clock can both be selected at the same time. Logo2 and the Clock cannot be selected/displayed at the same time.

PIP / KEY

LUMA PVW and LUMA PGM

A Luma key can be performed between 2 inputs and the result sent to the PVW and PGM display channels. See **Setting up a LUMA Key (Page 20)**

SET

If you want to enable the **PIP** function, you must first press the **SET** key, then press the **PIP PVW** key and then select the Sub Source channel for the PIP window. The size and position of the window can be set within the System Configuration Menu. See **PIP SETTING (Page 14)**

PIP PVW

Allows the user to see what the PIP window will look like and make any adjustments before the PIP window is taken to the PGM output. Pressing the PIP PVW button toggles the PIP window on and off using a simple dissolve.

PIP PGM

Once the PIP window is ready to be taken to air the PIP PGM button will allow a simple dissolve in and out over the top of the current program output.

Transition Effects

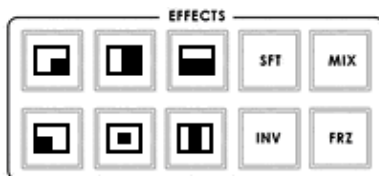

There are 10 Transition Effects keys. Six of these keys relate to the available types of **WIPE** effect. **INV** (Invert) changes the direction of the chosen **WIPE**. **SFT** changes the softness of the **WIPE** edge. **FRZ** freezes the current PGM image until toggled off or **CUT** away. **MIX** is a dissolve effect between the PVW and PGM sources.

For more information, see **Transition Effects (Page 12)**.

Transition Speed

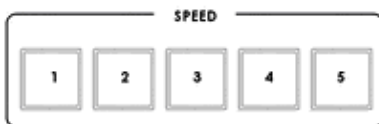

Five buttons used to choose different speeds for a transition effect when using the TAKE button to switch between PVW and PGM sources.

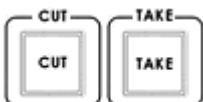

CUT

Forces an immediate switch between the selected main and sub sources. The selected sub source becomes the main program output with no transition effect applied.

TAKE

Starts an automated switch between the main and sub sources. The selected sub source becomes the main program output with the selected **Transition Effect** applied at the selected **Effect Speed**.

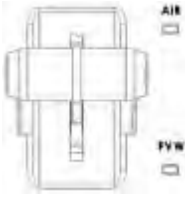

T-Bar

The T-Bar is used to carry out a manual transition such as a wipe, fade, mix or key. When it has travelled as far as it can go the transition is complete.

How to calibrate the T-bar:

1. Turn off the SE-2000 power, and push the T-Bar up as far as it can go to its Top or AIR position then move the T-Bar back down by 2mm.
2. Press and hold in the SET and SUB SOURCE 1 buttons at the same time.
3. Have a colleague turn on the SE-2000 power. When the SET button and SUB SOURCE 1 buttons are illuminated yellow release both buttons.
4. Push down the T-Bar as far as it can go to its bottom or PVW position and then move the T-Bar back up by 2mm. Now press the CUT button.
5. Again push the T-Bar up as far as it can go to its Top or AIR position. Now press the TAKE button.
6. Press SET button again to end the calibration process.

WARNING: If you do not follow the T-Bar calibrating steps correctly the T-Bar may work incorrectly

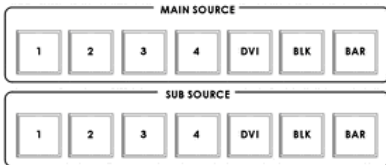

Main Source

Used to select which of the source input channels or backgrounds that are sent to the Main video PROGRAM output. For more information, see **Video Source (Page 12)**.

Sub Source

Used to select which of the source input channels or backgrounds will be transitioned to or used as a sub source in an effect such as PIP.



Headphone

Accepts a stereo mini jack plug for stereo headphones. Used with the Audio Monitor Button. The headphone volume is adjusted by the rotating Head phone volume control.

Headphone Volume Control

Controls Headphone volume level.

Use the Headphone section to accurately monitor any of the sources (CH1, CH2, CH3, CH4 or "Master") output.

Rear Panel

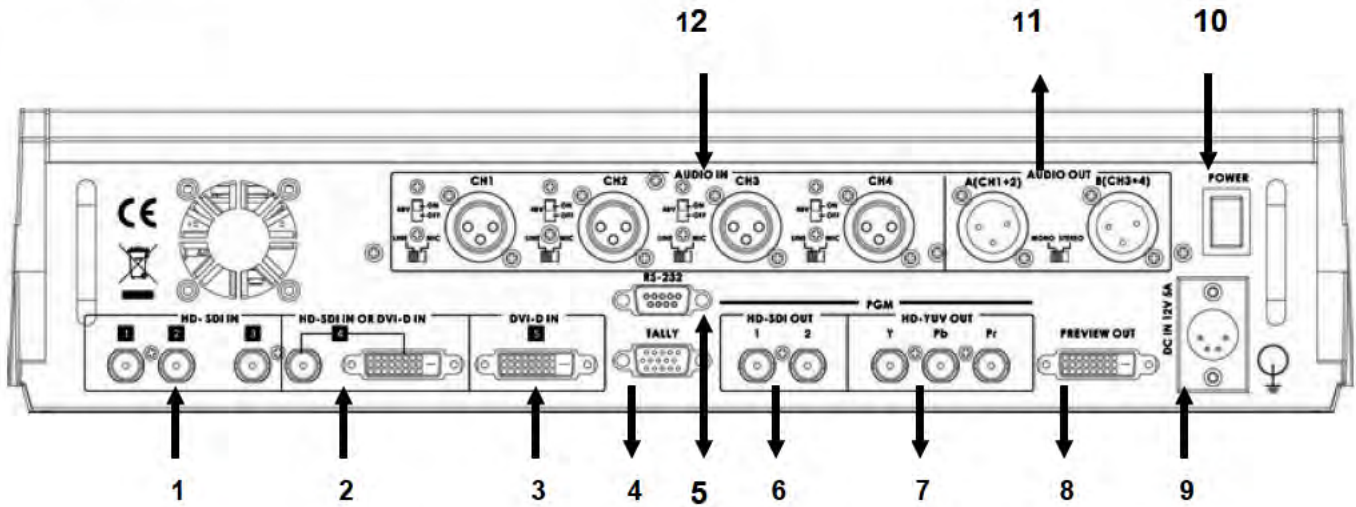

- | | |
|---------------------------|----------------------------|
| 1. HD- SDI INPUTS 1~3 | 7. HD- YUV PGM OUT |
| 2. HD- SDI IN or DVI-D IN | 8. DVI-D MULTI PREVIEW OUT |
| 3. DVI-D IN | 9. DC IN 12V 5A |
| 4. TALLY Output | 10. POWER ON / OFF |
| 5. FOR FIRMWARE ONLY | 11. AUDIO OUT |
| 6. HD- SDI PGM OUT | 12. AUDIO IN |

Rear Panel Connections

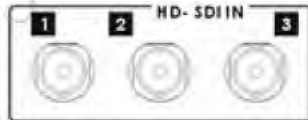

1. HD- SDI IN

Inputs 1 to 3 are HD-SDI inputs only on BNC connections.

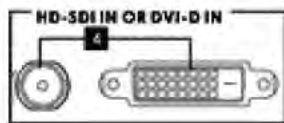

2. HD- SDI IN / DVI-D IN

Input 4 has a choice of two connections **HD-SDI** (via BNC) or **DVI-D**.

You select the connection you wish to use - for more information, see **INPUT 4 MODE (Page 15)**.



3. DVI-D IN

DVI-I Signal Input (Digital Input 5).



4. TALLY

Tally out socket. This supplies tally light information to the Datavideo ITC-100 system (not supplied).



5. RS-232

9-pin serial port standard RS-232 interface.

Connect PC to update firmware, Logos or Mixer Configuration.

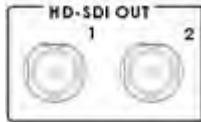

6. HD- SDI OUT

4:2:2 SDI Video data supports SMPTE 292M standard at 1.5G Mbps.

SDI transfers professional level video signals and it's can connect to long distance transmission systems.

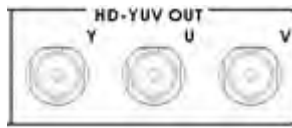

7. HD- YUV OUT

HD- YUV component analogue output connectors.



8. MULTI PREVIEW OUT

DVI-D digital signal preview output connector (PVW).



9. DC IN

DC in socket connect the supplied 12V 5A PSU to this socket. The connection can be secured by screwing the outer fastening ring of the DC In plug to the socket.



10. POWER

Switches the power On / Off.



11. AUDIO OUT

Supports two channels XLR Balanced Audio output.

12. AUDIO IN

The SE-2000 supports four XLR Balanced Audio Input channels.

There are two kinds of switches under **AUDIO IN**:

The **LINE/MIC** switch is used to set the audio as LINE in or MIC in.

The **48V ON/OFF** switch is for phantom power. If you want to use MIC in, please set the **LINE/MIC** switch first, and then if using a Condenser microphone turn ON the **48V ON/OFF** switch. If you wish to use a Dynamic microphone please turn OFF the **48V ON/OFF** switch.



Multi Preview Output

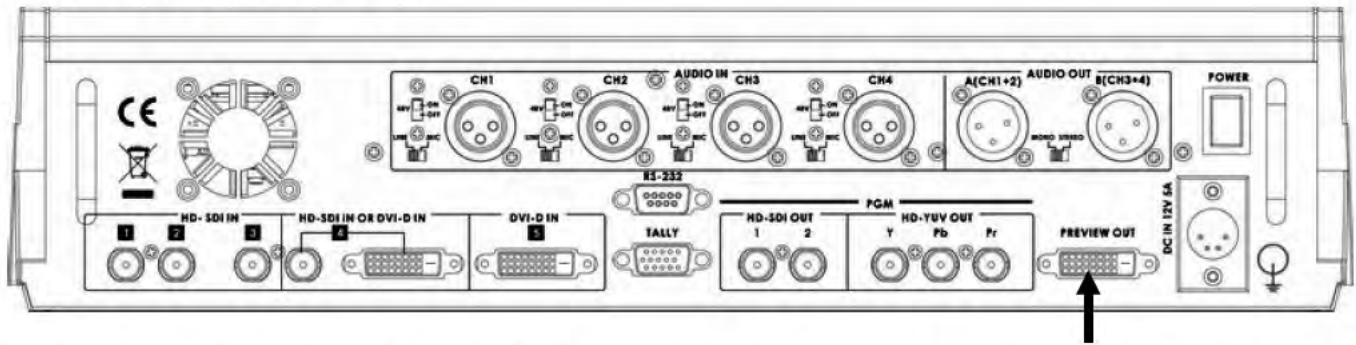

The Multi Preview output on the rear of the SE-2000 should be connected to a compatible 19" to 24" LCD monitor via a DVI-D cable connection. This Multi Preview display output can be run at 1080i or 720p [60Hz].



The Multi Preview display confirms at a glance the values for **Clock**, **Transition**, **User Profile**, **Input 4** and **HD Mode** as well as indicating which sources are selected for **PiP**, **PREVIEW** and **PROGRAM**.

The 8 downscaled image windows of the Multi Preview Display are not full HD resolution and should only be used for choosing the next source to be selected for either PiP, Preview or Program.

In the diagram above Input source 3, labelled as '**IN 3 CAMERA 3**', has a red indicator on the right hand side showing this source is also the current **PROGRAM** or Main Source.

In the diagram above Input source 1, labelled as '**IN 1 CAMERA 1**', has a Yellow indicator on the left hand side showing this source is also the current **PREVIEW** or Sub Source.

When the T-Bar; TAKE or CUT buttons are used the indicator will change to Red on the right hand side of '**IN 1 CAMERA 1**' showing that input source 1 is now being sent to the **PROGRAM** output instead of Input 3.

Main Source and Sub Source Rails

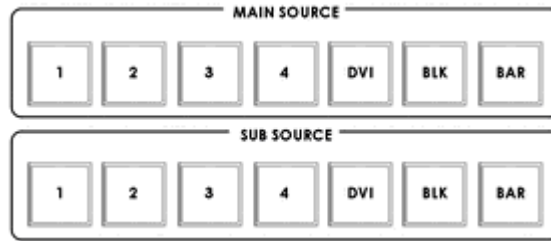

The Main Source Rail shows the active channel, this is the Live output. The active channel will also appear as the Program Output (PGM). You can immediately switch or CUT from one input channel to another directly on the Main Source Rail, you will see the PROGRAM Output switch as you press different keys along this rail. As each key is selected or pressed it will turn Red.

The Sub Source Rail shows the Cued channel, the selected channel will appear in the Preview window. The selected key will turn Yellow. The Sub Source selection determines which input will be transitioned to when using any of the transition controls and provides the Sub Source video for Picture in Picture and Key functions.

Transition Effects

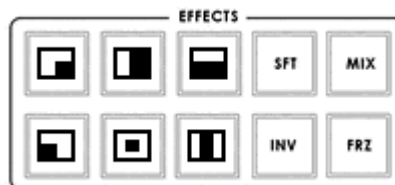

1	WIPE from upper Left corner to lower Right corner of screen
2	WIPE from Left to Right of screen
3	WIPE from Top to Bottom of screen
4	WIPE from upper Right corner to lower Left corner of screen
5	WIPE from outside edge of screen to centre of screen
6	WIPE from Left and Right hand sides into the center of the screen
7	SFT Controls the border softness of the WIPE or effect.
8	MIX Also known as a fade or dissolve, is a transition where all the pixels of one source are replaced by all the pixels of another, at a smooth rate, and at the same time.
9	INV Inverts the WIPE direction – the chosen WIPE moves in the opposite direction.
10	FRZ This freezes the PGM video, press it again, and it returns to the selected Live PGM source.

System Configuration Menu

Menu and Navigation

Press the **MENU** button in the *Function* section of the SE-2000's keyboard to enter the *System Configuration Menu*. The menu will be displayed on the SE-2000's Multi Preview output as below.

Press the **UP**, **DOWN**, **LEFT** and **RIGHT** arrow buttons to highlight or select a menu option. Then use the **UP** and **DOWN** arrow buttons to change the value of the selected item or option. Press the **ENT** button to *Enter* and save your chosen value for the selected menu item.

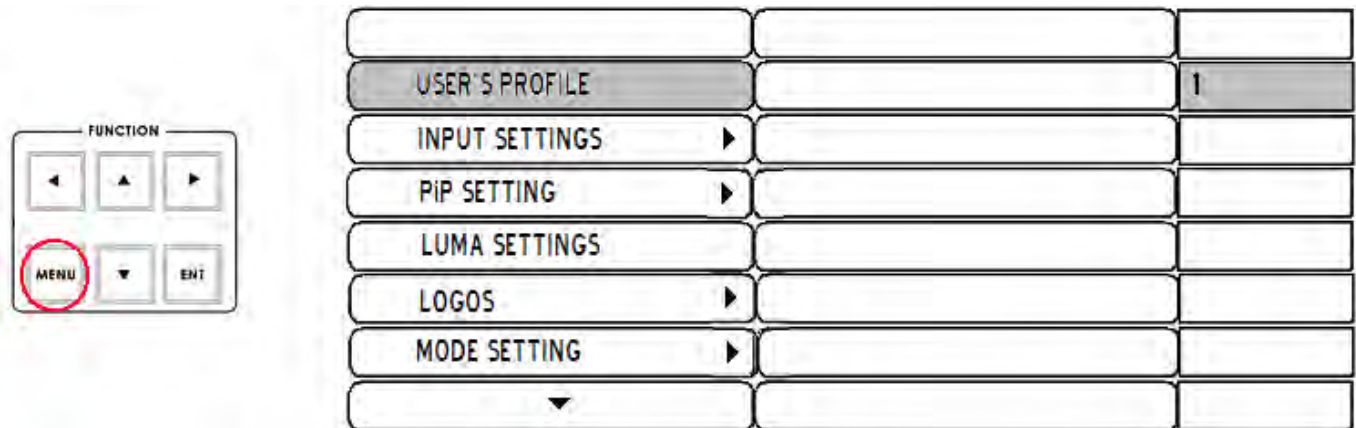

USER'S PROFILE

- Press the **MENU** button and highlight the **USER'S PROFILE** option.
- Press the arrow **RIGHT** button and select a profile number by using the **UP** and **DOWN** arrows.
- Press the **ENT** button to confirm the chosen profile number to be used.

The current user will also be confirmed between PREVIEW and PROGRAM windows on the Multi Preview Display.

- Up to 6 User Profiles can be configured and saved. These profiles are numbered 0 ~ 5.
- **User's Profile 0** is also referred to as the **BASIC or MASTER USER** settings profile.

*If there are settings that will be common to all user profiles 1 ~ 5 then they are set here first under **BASIC** and then these common settings can be copied to the other user profiles (1 ~ 5) by selecting **LINK TO BASIC**. Then while adjusting USER 1 ~ 5, you can refer to the **BASIC** settings, thus avoiding multiple and repeated adjustments for all remaining user profiles.*

- Any changes made to the SE-2000's configuration will be saved to the currently selected profile.
- The default user profile at Power On is the last selected profile used.

INPUT SETTINGS

- Press the **MENU** button and highlight the **INPUT SETTINGS** option.
- Press the arrow buttons to select an item and press the **ENT** to confirm the setting.
- **BRIGHTNESS**: adjustment range from -7 to +7
- **CONTRAST**: adjustment range from -7 to +7
- **SATURATION**: adjustment range from -7 to +7
- **MASTER USER SETTING**: When selected, the values for the above are copied from the **BASIC** profile.

PIP SETTING

- Press the **MENU** button and highlight the **PIP SETTING**.
- Press the arrow buttons to select an item and press the **ENT** to confirm the setting.
- **X- POSITION:** adjustment range from 0 to +102 (**when MODE SETTING is 1080i**)
- **Y- POSITION:** adjustment range from +113 to 0 (**when MODE SETTING is 1080i**)
- **X- POSITION:** adjustment range from 0 to +70 (**when MODE SETTING is 720p**)
- **Y- POSITION:** adjustment range from +77 to 0 (**when MODE SETTING is 720p**)
- **SIZE:** adjusts the size of the smaller PIP window using a range from +1 to +97
- **MASTER USER SETTING:** When selected, the values for the above are copied from the **BASIC** profile.

If you want to enable the **PIP** function, you must first press the **SET** key in the PIP / KEY section of the SE-2000 keyboard, then press the **PIP PVW** key and then select the Sub Source channel required for the PIP window.

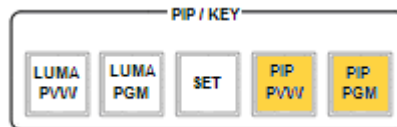

The **PIP** window will appear on the PREVIEW and PROGRAM displays when **PiP PVW** and **PiP PGM** buttons are lit on the SE-2000's Keyboard.

LUMA SETTING

- Press the **MENU** button and highlight the **LUMA SETTING** option.
- Press the arrow buttons to select an item and press the **ENT** to confirm the setting.
- You can set the value for the **LUMA LEVEL** (0 Black to 255 White)
- This **LUMA LEVEL** keys out a grey scale range between 0 and the **LUMA LEVEL** value set.
- So **LUMA LEVEL 20** would key out a range of Black between 0 and 20 from the Sub source.
- **MASTER USER SETTING:** When selected, the value for the above is copied from the **BASIC** profile.

LOGOS

- Press the **MENU** button and highlight the **LOGOS** option.
- Press the arrow buttons to select an item and press the **ENT** to confirm the setting.
- You can select a pre-loaded Logo from the SE-2000's 14 memory slots for **Logo1** and **Logo2**.
- You can set the on screen positions of **Logo1**, **Logo2** and the **Clock**.
- **X- POSITION:** adjustment range from 0 to +114 (**under 1080i**)
- **Y- POSITION:** adjustment range from +112 to 0 (**under 1080i**)
- **X- POSITION:** adjustment range from 0 to +72 (**under 720p**)
- **Y- POSITION:** adjustment range from +150 to 0 (**under 720p**)
- Accepted Logo sizes 256x192 pixels, 512x96 pixels or 128x384 pixels
- **MASTER USER SETTING:** When selected, the values for the above are copied from the **BASIC** profile.

Logos need to be loaded into the 14 memory slots in preparation before an event – See Storing New Logos (Page 21).

MODE SETTING

- Press the **MENU** button and highlight the **MODE SETTING**.
- Press the arrow buttons to select an item and press the **ENT** to confirm the setting.
- This Mode setting is used to adjust the HD input mode.
- HD Mode values can be **1080/50i** - **1080/60i** - **1080/59.94i** - **720/50p** - **720/60p** or **720/59.94p**
- **MASTER USER SETTING:** When selected, the values for the above are copied from the **BASIC** profile.
- Please ensure your HD input source(s) match the HD mode of the SE-2000.

The selected HD mode is confirmed between the PREVIEW and PROGRAM windows on the Multi Preview Display.

MONITOR MODE

- Press the **MENU** button and highlight the **MONITOR MODE** option.
- Press the arrow buttons to select an item and press the **ENT** to confirm the setting.
- This mode adjusts the Multi Preview DVI-D output between **1080i 60Hz** and **720p 60Hz**.
- **MASTER USER SETTING:** When selected, the values for the above are copied from the **BASIC** profile.

INPUT 4 MODE

- Press the **MENU** button and highlight the **INPUT 4 MODE** option.
- Press the arrow buttons to select an input option and press the **ENT** to confirm the setting.
- This mode is used to switch INPUT 4 from HD-SDI input to DVI-D input and vice versa.
- **MASTER USER SETTING:** When selected, the values for the above are copied from the **BASIC** profile.

The changed setting will also be confirmed between PREVIEW and PROGRAM windows on the Multi Preview Display.

MASTER USER SETTING

- Press the **MENU** button and highlight the **MASTER USER SETTING** option.
- Press the arrow buttons to select an item and press the **ENT** to confirm the setting.
- This mode is used to return the SE-2000 **BASIC** profile (**USER 0**) to its factory default settings.
- If the **BASIC** profile is changed then any USER profiles (1 ~ 5) linked to **BASIC** will also be changed.

SOFT EDGE

- Press the **MENU** button and highlight the **SOFT EDGE** option.
 - Press the arrow buttons to select an item and press the **ENT** to confirm the setting.
- This mode is used to set the size of the soft border (**SFT** Key) when using a WIPE transition or the PIP effect.

AUTO TAKE SPEED

- Press the **MENU** button and highlight the **AUTO TAKE SPEED** option.
- Press the arrow buttons to select an item and press the ENT to confirm the setting.
- This adjusts the different speeds of the selected transition effect when the **TAKE** button is used.

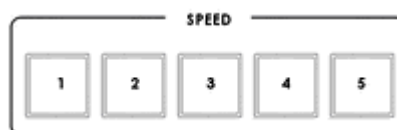

BACKGROUND

- Press the **MENU** button and highlight the **BACKGROUND** option.
- Press the arrow buttons to select an item and press the **ENT** to confirm the setting.
- This option sets the background colour of the Multi Preview screen – options are Black, Grey or Blue.

BLACK & BARS POS.RIGHT

- Press the **MENU** button and highlight the **BLACK & BARS POS.RIGHT** option.
- Press the arrow buttons to select an item and press the **ENT** to confirm the setting.
- This option allows the user to change the order of the keys on the Main and Sub Source rails.
- When selected the order of the keys will be BLK, BAR, 1, 2, 3, 4, DVI instead of the original sequence.
- Once changed the Key Cap Legends can be carefully removed and relocated to the new position.

BEFORE



AFTER

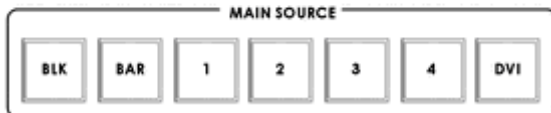

FACTORY SETTINGS

- Press the MENU button and highlight the **FACTORY SETTINGS** option.
- Press the arrow buttons to select an item and press the **ENT** to confirm the setting.
- This menu option is used when it is required to return the product back to its factory state.
- If you select this option then ALL user settings (BASIC and 1 to 5) are returned to their factory defaults.

CLOCK SETTINGS

- Press the **MENU** button and highlight the **CLOCK SETTINGS**.
- Press the arrow buttons to select an item and press the **ENT** to confirm the setting.
- This mode is used to set the clock within the SE-2000.

The current Clock value is displayed in between the PREVIEW and PROGRAM windows of the Multi Preview Display.

MAX BUTTON BRIGHTNESS

- Press the MENU button and highlight the **MAX BUTTON BRIGHTNESS** option.
- Press the arrow buttons to select an ON or OFF state and press the **ENT** to confirm the setting.
- This menu option is used when the Keyboard button back lights needs to be dimmed or made brighter.
-

TWO WAY T-BAR MODE

- Press the MENU button and highlight the **TWO WAY T-BAR MODE** option.
- Press the arrow buttons to select an ON or OFF state and press the **ENT** to confirm the setting.
- This menu option is used to change the T-BAR from one way to two way operation or vice versa.

Audio Inputs and Levels

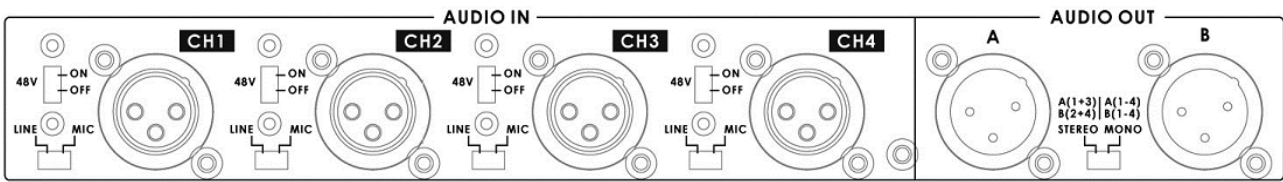

Analogue audio comes into the SE-2000 through the XLR connectors on the rear panel (see above diagram). The SE-2000 supports four XLR Balanced Audio Input channels.

There are two kinds of switches next to each XLR input under **AUDIO IN**:

The **LINE/MIC** switch is used to set the audio as **LINE** in or **MIC** in.

The **48V ON/OFF** switch is for *Phantom power*. If you want to use **MIC** in, please set the **LINE/MIC** switch first, and then if using a *Condenser microphone** turn **ON** the **48V ON/OFF** switch. If you wish to use a *Dynamic microphone* please turn **OFF** the **48V ON/OFF** switch.

***NOTE: Always double check the manual for the microphone being used to see what advice it gives regarding power as some Mics have internal batteries too.**

A+V

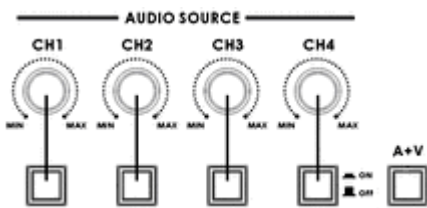

The Audio Input Channel Selectors and Level pots are the first stage in the audio signal path. Each channel carries the audio associated with a video input channel. When the A+V button is active, the audio follows the video through a transition. This means that when this LED is lit, only one channel of the Audio input section (CH1, CH2, CH3, CH4) can be activated at a time. When the transition is a CUT, the audio will switch

abruptly at the same time.

Try this: With the A+V button engaged or lit, select Channel 2 on the Main Source bus (of course, you must have a valid video and audio source connected). Notice that CH2 is lit in the Audio Source section. Now, select channel 1 on the Sub Source bus. Work the T-Bar to manually perform a transition (if no specific transition is selected, the sources will dissolve) and watch Audio Input Source channel change from CH2 to CH1, following the video.

When the A+V button is not engaged or off, you can manually select which of the 4 Audio input channels will be applied to the Video bus at the Fader. In fact, you have to select one or more of these channels, or there will be no audio present at the audio out connections.

The A+V button should be inactive while doing level settings at the beginning-of-session so that you can select an input and adjust the initial level correctly.

NOTE: Audio cannot be de-embedded by the SE-2000 from a HD-SDI input and Audio will not be embedded into the SE-2000's HD-SDI PGM outputs. For ideas on how best to do this before and after the SE-2000 mixer see Example SE-2000 Set Ups (Page 20).

Example SE-2000 Set Ups

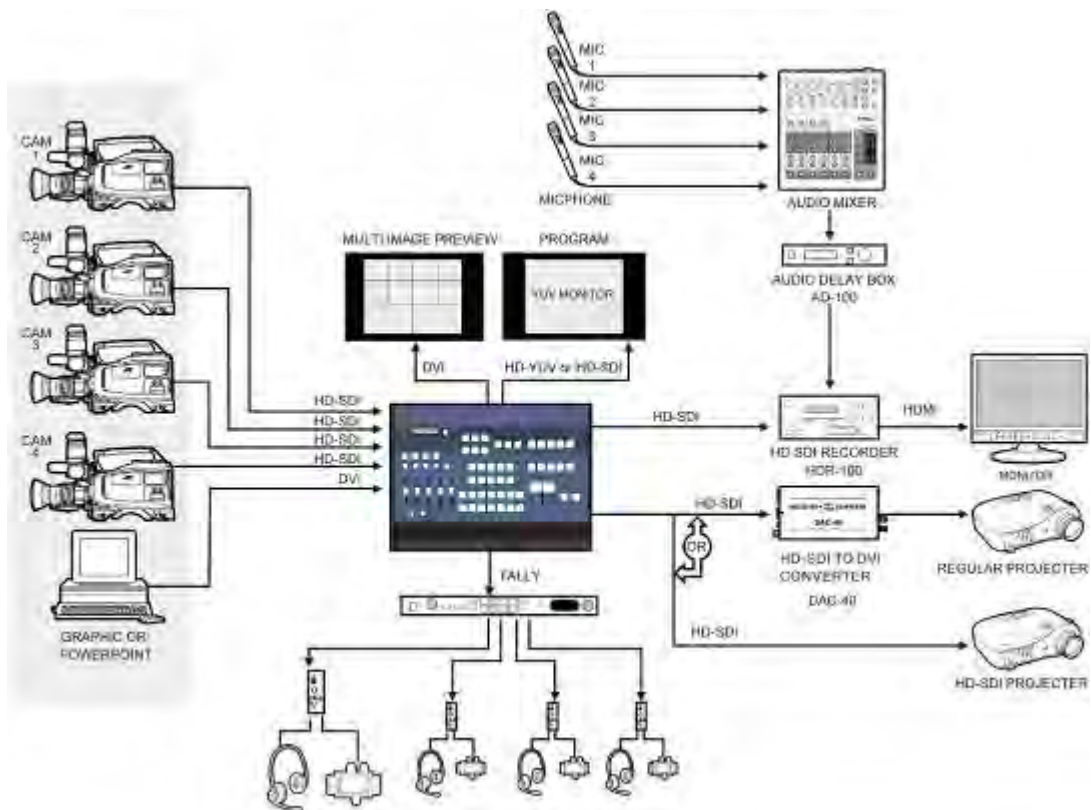
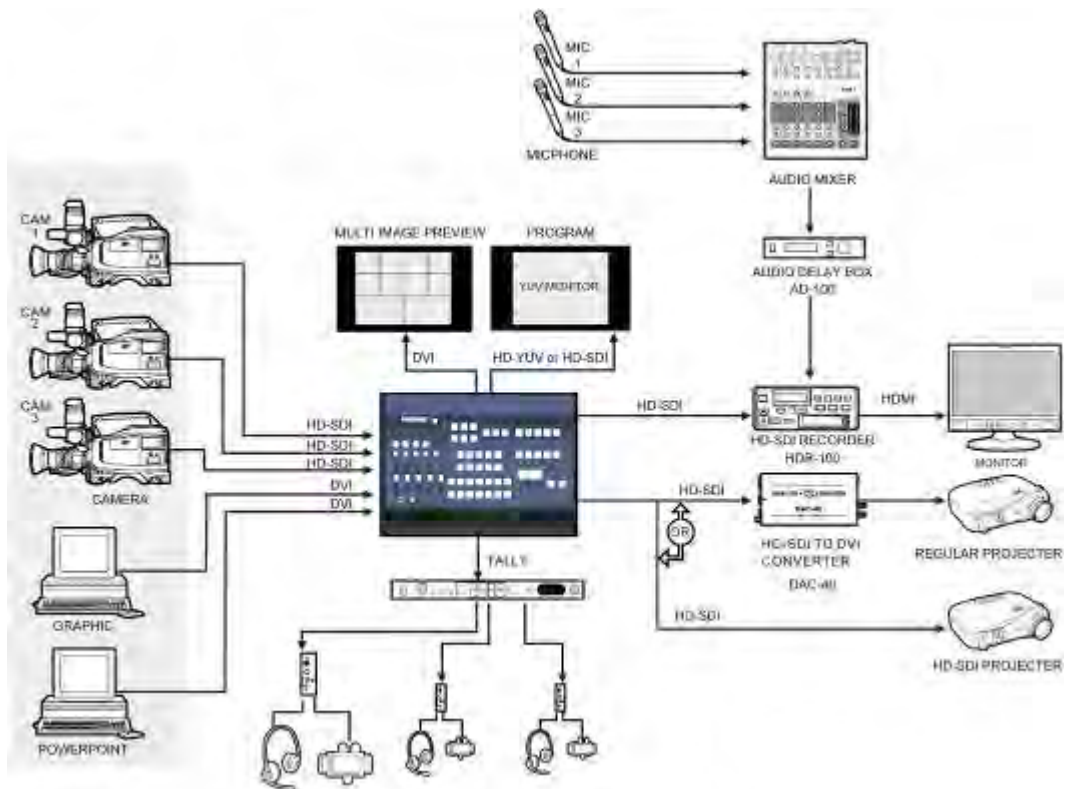

SE-2000 Configuration Utility

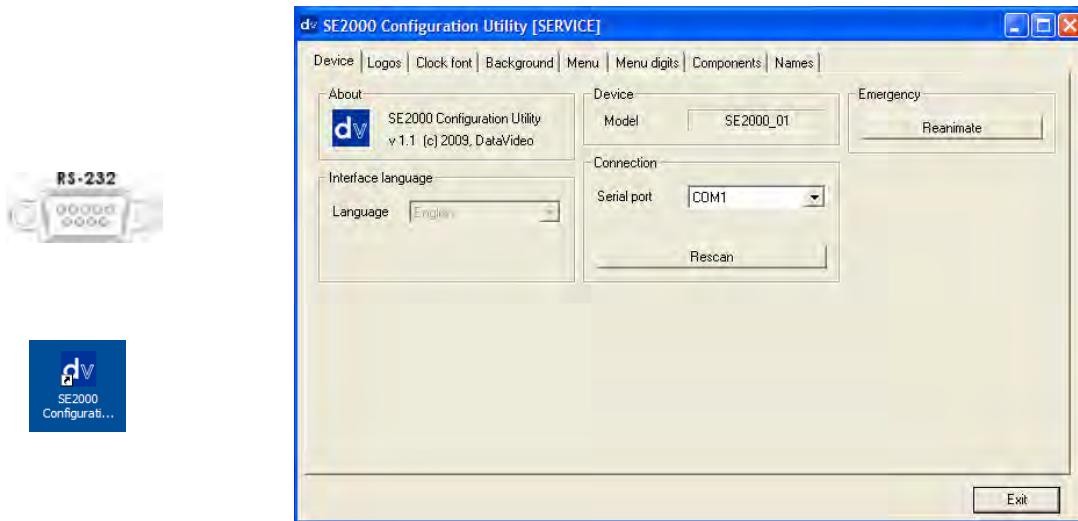

The Configuration Utility software allows a PC (running Windows XP Professional) to make changes to the mixer*. A cable needs to be connected between the RS-232 port on the rear of the SE-2000 and the PC COM1 Serial port.

This software Utility is free and can be downloaded from the following web page <http://www.datavideo.info/en/Mixer%20-%20Switchers/SE-2000>

Once downloaded, run the install wizard and follow the on-screen prompts. The installation will leave an Icon on the PC desktop as above. With the SE-2000 connected to the PC via an RS-232 cable, the initial utility screen will be displayed as above, when the program is launched. Select the Logos tab to make the required changes.

Storing New Logos

The Configuration Utility software above allows a Windows XP Professional PC to make changes to the Logos stored within the 14 memory slots of the SE-2000 mixer. This is done from the Logos tab shown below.

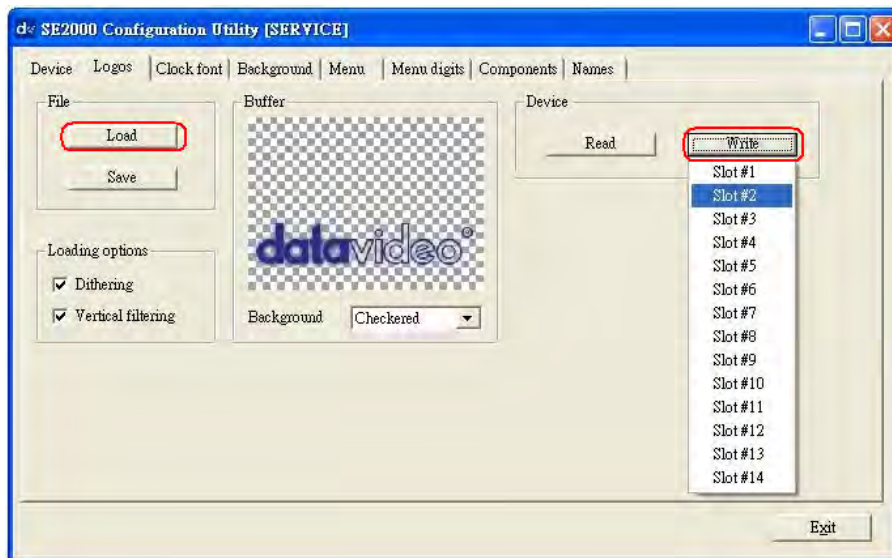

New Logos to LOAD and WRITE into these memory slots MUST be 256x192 pixels. Your new Logo needs to be created in a graphics software package first as a TGA 32bit or BMP 24bit file with a clear Alpha Channel background. The graphics software to create your Logo is not supplied by Datavideo.

How to change the input source labels

If you would like to change the input source labels on the Multi Image Preview Screen this can be done using the SE-2000 Configuration Utility (see top of previous page for PC set up and software).

1. Run the program "SE2000 Configuration Utility Service"
2. Mouse click on the "Names" tab.
3. Within the "Text Label" option, type the new label for your chosen input source.
4. Click "Write" button and select the source label that you wish to change.
5. Click "Yes" button to continue.
6. Wait for it to write the new label text to the switcher's memory.
7. The "Write Complete" message will appear.
8. Click OK then Exit the software and check the Multi Image Preview Screen after restarting the switcher.

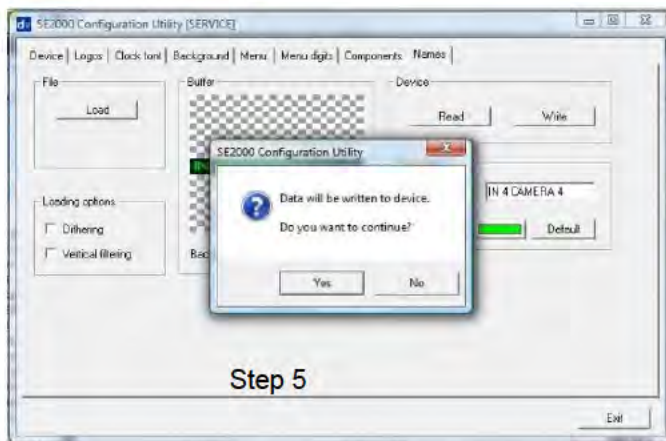
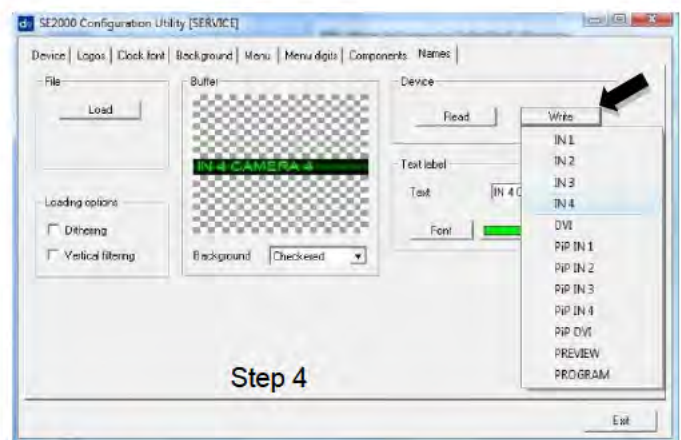

Setting up a Luma Key overlay with PowerPoint

The SE-2000 has 5 inputs. Input 5 is DVI only and this can be used to connect a DVI-D cable from a computer's monitor/graphics card. The PC graphics card will need 2 connections 1 for the PC monitor and a spare DVI-D connection to go to input 5 on the SE-2000. The PC will need to have *Microsoft Office* installed in order for *PowerPoint* to be used. If all the settings are correct on the mixer and the PC then we can attempt to use this computer display output to create a simple text overlay using the SE-2000's Luma Key function.

1. Connect a DVI-D cable between the SE-2000 and the spare DVI port on the PC's graphics card.
2. Turn on the SE-2000 and then the PC.
3. Create a *PowerPoint* presentation with White text on a Black background. You may want to create your own *Slide Master* within *PowerPoint*. **Use the *PowerPoint Help* function for advice on how to do this.**
4. Select DVI on the sub source rail of the SE-2000 so it is shown in the PREVIEW window. Check the Multi Preview Display on the SE-2000, can you see the PC output in the DVI VTR2 or PREVIEW window?
5. If you cannot see the computer output extend the PC's desktop within Windows to monitor 2 as below.



6. PC screen size for monitor 2 should match the HD resolution, for example 1920x1080 or 1280x720.
7. If DVI VTR2 is just a blue screen (blue desktop background only), then try using the PC mouse pointer to drag a window or a desktop icon across and onto the SE-2000 DVI VTR2 window.
8. OK, so you should now have the Monitor 2 PC display running into input 5 on the SE-2000.
9. Open up *Powerpoint* on the PC and use *Set Up Show* so that the presentations play back on Monitor 2 (the SE-2000) and the presentator's output is sent to Monitor 1 (the PC's own monitor).

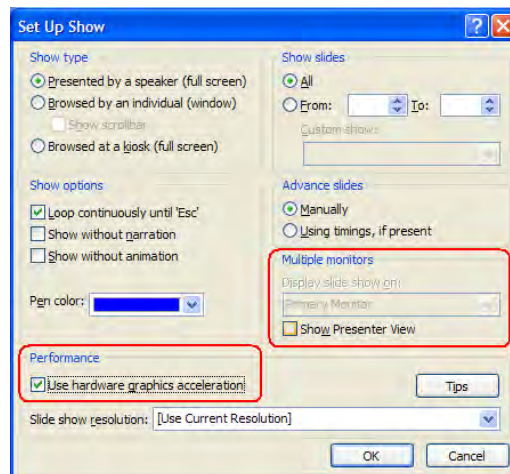
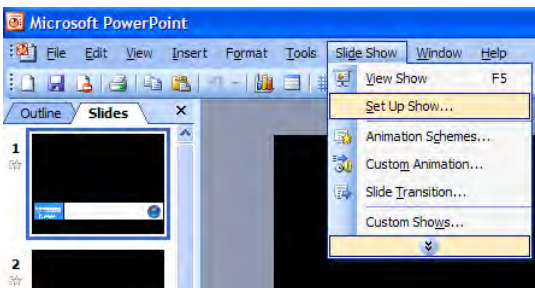

10. Ensure DVI is selected on the SE-2000 Sub Source rail and a video input is chosen on the Main Source rail.
11. Now that you can see the presentation playing back in the PREVIEW window we can now attempt to key out the Black parts of the Presentation using the **LUMA SETTING** option in the SE-2000's System Configuration menu whilst the **LUMA PVW** button is also ON. See **LUMA SETTING** on **page 15** also.
12. Once you have the right LUMA SETTING or overlay effect in the PREVIEW window you can then press **LUMA PGM** key to toggle the overlay effect ON or OFF the main PROGRAM output.

HD-SDI Cabling Advice

Start with good cabling. BNC coax cables and connectors are not all made to the same standard. From the thickness and grade of the centre conductor to the type of dielectric, all these factors contribute to impedance, attenuation and Return Loss (RL). Serial Digital Video coax like Belden 1694A or Canare L5CFB are good examples of broadcast quality SDI cable.

A 75 Ohm (Ω) impedance must be maintained throughout the SE-2000 SDI signal or cable path, including BNC connectors etc.

Return Loss is the portion of the transmitted SDI signal that is not admitted to the receiver and is then reflected back along the cable toward the transmitter (DAC-9). Reflections in the transmission path will cause attenuation as well as distortion of the SDI signal received. The signal is attenuated because part of it is reflected back and does not make it to the receiver (SE-2000 for example); it is also distorted because the reflected signal mixes with the original signal causing it to distort as well as adding to the noise floor.

Care must also be taken with cable length, as it will affect the error rate in the SDI signal. Cable lengths beyond acceptable limits will see error rates reach a tipping point and this will bring about a total loss of picture also known as the **Cliff Effect**. Always check with your supplier for cabling advice on the maximum distance for a particular signal and data rate, in this case an SDI signal that complies with the SMPTE 292M standard at 1.5 Gbps. Datavideo Taiwan have determined that single BNC SDI cable (5CFB) runs of up to 100m should be possible with this unit before the signal would need to be re-clocked or repeated.

Here is a basic list of other things to avoid

- Do not step on or rest equipment on the cables.
- Do not roll dollies or trolleys over the cables.
- Do not put kinks or sharp bends in the cables.
- Do not exceed the minimum bend radius of the cable.
The general rule for an acceptable bend radius is 10 times the diameter of the cable.
- Cable pulls should be done carefully – do not jerk or stretch the cable(s).
Do not exceed the cable's maximum pulling tension.
(call the cable supplier / manufacturer for this information.)
- Do not pull cable ties too tight on cable looms.
If you cannot move any cable inside a loom tie, the tie is too tight.
Put an extra piece of cable in when tightening loom ties - then remove it afterwards to create the space.
- Do not put cable management fixings at standard distances apart.
This can lead to deformity at a given wavelength, which can increase RL.
Place your loom cable ties at random distances for the same reason.

How to update SE-2000 firmware

From time to time Datavideo may release new firmware to either add new features or to fix reported bugs in the current mixer firmware. Customers can update the mixer firmware themselves if they wish or they can contact their local dealer or reseller for assistance should they prefer this method.

This page describes the firmware update process, two programs will be used and it should take **approximately 40 minutes total time to complete**.

Once started **the update process should not be interrupted in any way** as this could result in a non-responsive mixer.

As well as a working mixer you will need:

- The latest Flash Update for the mixer. This can be obtained from your local Datavideo office.
- The latest SetUp program for the mixer. See Page 20.
- A 9 pin Sub D male to female RS-232 cable. Pin 1 connects to pin 1, pin 2 connects to pin 2, etc.
- A Windows XP Professional 32bit PC with a 9pin Sub D COM1 port.

Save the two programs to the PC desktop so you can find them easily.

Stage 1. Run the **FlashUpdate_SE2000_xxxx** program. (where **xxxx** represents the version number)
This first part of the update process should take 20 minutes to complete.

Ensure the mixer is switched OFF. Connect the mixer using the sub D 9pin cable between the PC COM1 port and the mixer's RS-232 port. Double click the **FlashUpdate_SE2000_xxxx** application.

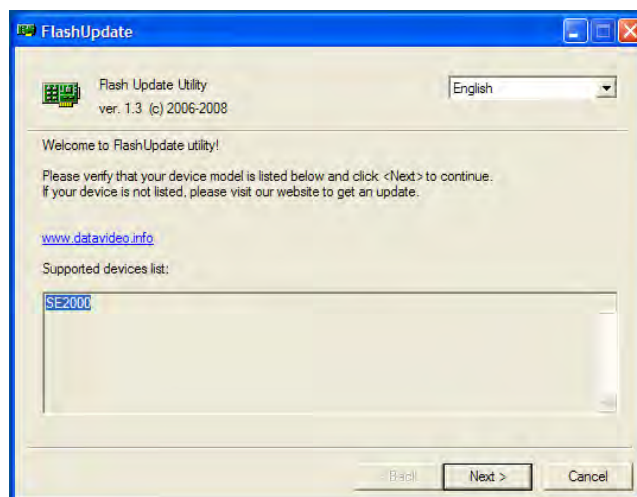

Click NEXT then select the option for the COM1 port on the PC and click NEXT.

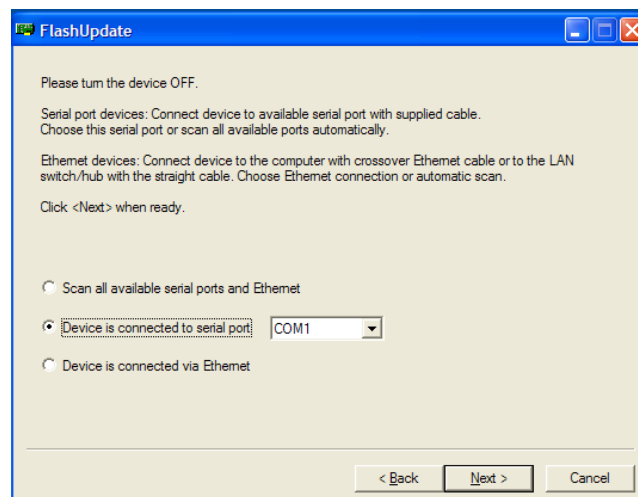

Now turn the mixer ON. Once the application discovers the mixer it will check the firmware on the mixer and report if it needs updating. Click NEXT to start the update. You will be asked to confirm that you want to proceed click YES. A progress bar will then be shown as below.

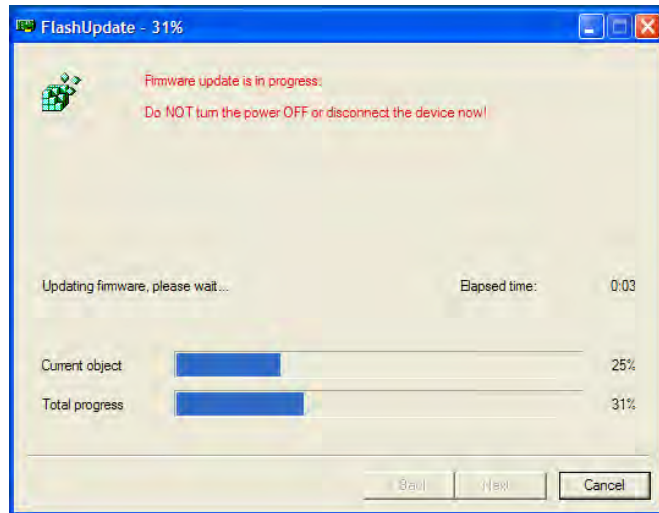

Once complete (100%) the application will ask you to power the mixer OFF and then back ON again. Once the keyboard lights on the mixer are steady again and the multi Preview image is shown from the mixer move onto Stage 2 below.

Stage 2. Run the **SE2000_SetUp_V2.3** program.

This second part of the update process and should also take 20 minutes to complete.

The mixer will still be connected with the sub D 9pin cable to the PC's COM1 port. Ensure the mixer is switched ON. Double click the **SE2000_SetUp_V2.3** program and on the first screen click on the **reanimate** button.

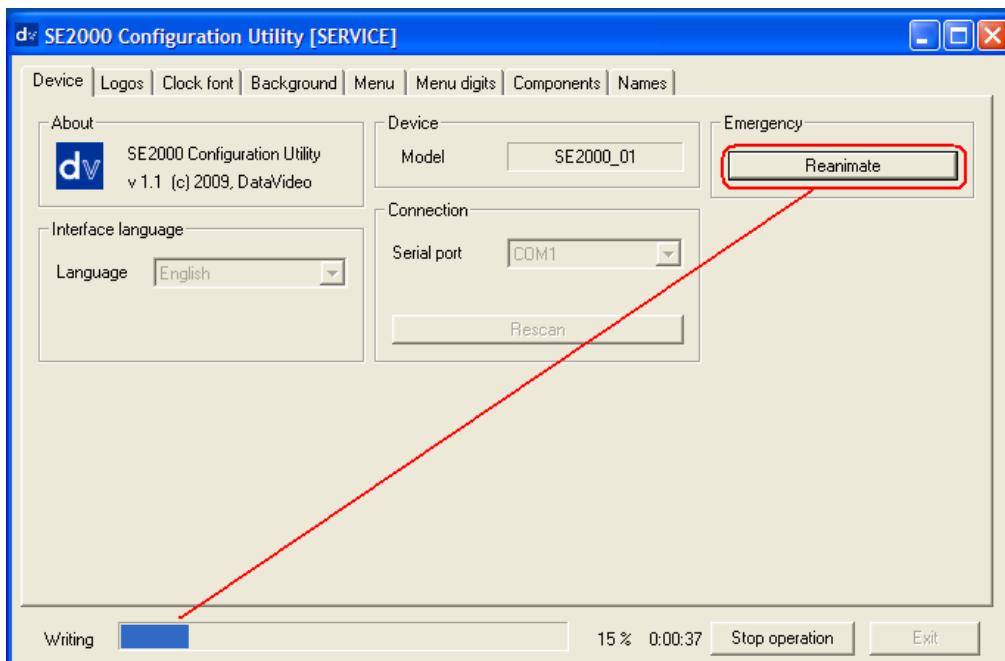

You will be asked to confirm that you want to proceed click YES. A progress bar will be shown, once finished (100%) exit the application and power the mixer OFF and then switch it ON.

That is it, the new features or bug fixes should now be in place within the mixer.

SE-2000 bespoke Tally cabling advice

Datavideo have designed this mixer to work with their own Datavideo wired tally light systems. For more information on the ITC-100 and TB-5 please approach your local Datavideo dealer or office.

This page shows information for people wishing to create their own bespoke cabling for the purpose of connecting an ITC-100 or TB-5 unit to the Tally Output connection on the rear of the SE-2000 mixer. If wish to have this option but do not have the necessary skills to make this cable then please contact your local dealer or Datavideo office who may be willing to assist in the creation of a cable.

NOTE: Please be aware that power runs through the cable and a lack of understanding in building either cable may result in damage to the mixer or the external tally unit. Where damage happens in this way the warranty on either unit will be invalidated and there may be a chargeable cost for the repair. Please ask for assistance if you are not sure.

SE-2000 to ITC-100 bespoke Y cable configuration

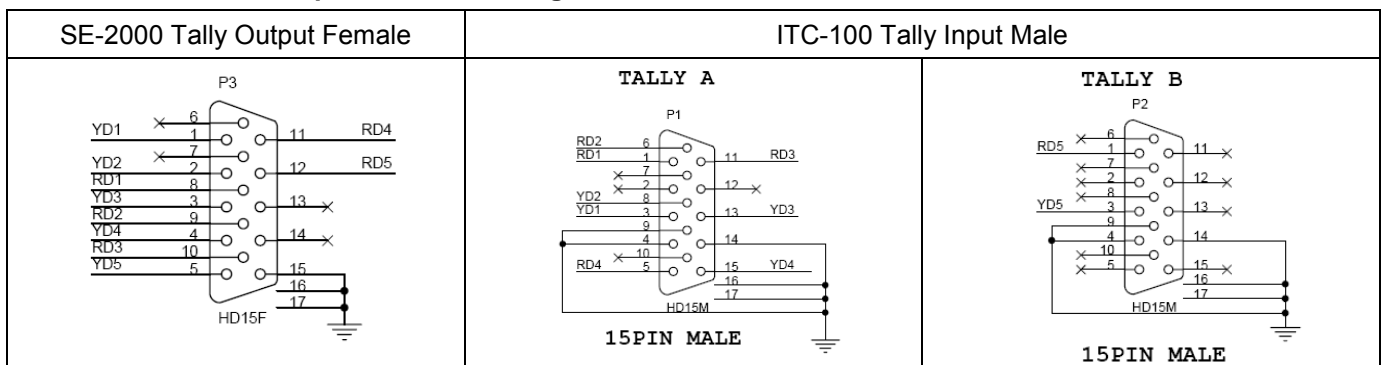

SE-2000 to TB-5 Tally Box bespoke cable configuration

Some customers will want to use the Tally output of the SE-2000 just for Datavideo’s unique Bi-colour tally system without using the ITC-100. In this case a TB-5 Tally Box and the following cable will be required instead.

NOTE: Please be aware that power runs through the cable and a lack of understanding in building the cable may result in damage to the mixer or the external tally unit. Where damage happens in this way the warranty on either unit will be invalidated and there may be a chargeable cost for the repair. Please ask for assistance if you are not sure.

Revised SE-2000 to TB-5 cable pin lay out will be:

RED LED / Actual / Live

	Camera 1	Camera 2	Camera 3	Camera 4	Gnd
TB-5	1	6	4	5	14
SE-2000	8	9	10	11	15

AMBER LED / Cue / Next

	Camera 1	Camera 2	Camera 3	Camera 4
TB-5	3	8	13	15
SE-2000	1	2	3	4

SE-2000 RS-232 Remote Control Protocol Communication diagram

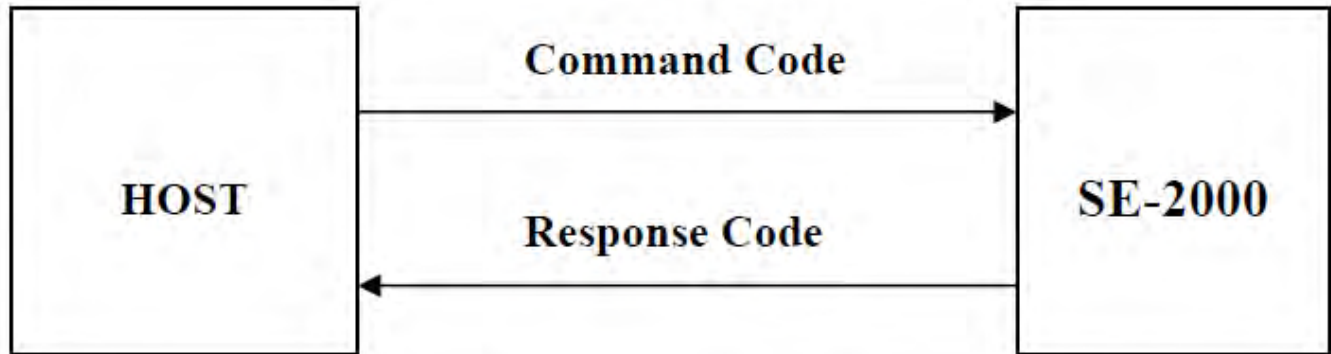

Control Interface

Interface	RS232
Baud Rate	115200
Data bits	8
Parity	None
Stop bits	1

Pin Assignment

D-Sub 9pin Female

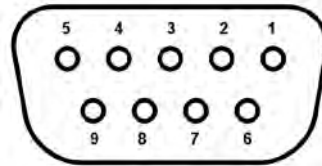

The pin assignment of the Host Controller and SE-2000 is shown in the following table:

Pin	Host		SE-2000
2	Receive A (RX-)	←	Transmit A (TX-)
3	Transmit B (TX+)	→	Receive B (RX+)
5	Common	---	Common

Command Code Format

13 Bytes(Hex)

1	2	3	4	5	6	7	8	9	10	11	12	13
E2	E4	0F	00	FF	01	FE	40	02	COM	ARG	CRCL	CRCH

COM , ARG : Reference to (Table 3)

Response Code Format

N Bytes(Hex)

1	2	3	4	5	6	7	8	9	...	N-1	N
E2	E4	FF	01	0F	00	FE	ERR	Len		CRCL	CRCH

ERR : C0 (No Error) , other code (have error)

Len : Response data code

CRC (CRCL,CRCH)

Check sum! It is transmitted lower byte first.

All the bytes except the last 2 from the block are used to calculate the check sum. There must be 0x0000 after the check sum calculation including the last 2 bytes, if the data have been transmitted error free.

The initial value for check sum calculation is 0xFFFF.

The check sum polynomial and examples for the algorithm realization are given in the “Application Note 27.

Understanding and Using Cyclic Redundancy Checks with Dallas Semiconductor iButton™ Products (www.dalsemi.com), in the “CRC-16 computation for ram records in iButtons” section.

CRCL and CRCH can be calculated , particularly, by means of the tables 1 and 2 according to the rule below:

$CRCH' = Tbl.2(I),$

$CRCL' = Tbl.1(I) + CRCH,$ where $I = CRCL + InputByte$

CRCH and CRCL correspond to higher and lower byte of the current check sum value, InputByte – next data byte.

CRCH' and CRCL' correspond to higher and lower byte of the new check sum value. Tbl.2 (I) and Tbl.1 (I) correspond to the tables' values, I is the shift factor in the tables. «+» means bit-wise XOR.

```

unsigned short ComPort_Flag;
unsigned short CMD_Length;
unsigned char CMD_Buf[128];

void Cal_Checksum(void)
{
    int i;
    unsigned char crc_lo,crc_hi;
    unsigned char new_crc_lo,new_crc_hi;
    unsigned char temp;

    crc_lo=CMD_Buf[CMD_Length-2];
    crc_hi=CMD_Buf[CMD_Length-1];
    for(i=0;i<(CMD_Length-2);i++)
    {
        temp=crc_lo^CMD_Buf[i];
        new_crc_hi=CRC16_TABLE_HI(temp); // Reference to Table 1
        new_crc_lo=CRC16_TABLE_LO(temp)^crc_hi; // Reference to Table 2
        crc_lo=new_crc_lo;
        crc_hi=new_crc_hi;
    }
    CMD_Buf[CMD_Length-2]=crc_lo;
    CMD_Buf[CMD_Length-1]=crc_hi;
}

```

```

void MainSource1()
{
    // TODO: Add your control notification handler code here
    CMD_Length=13;
    CMD_Buf[0]=0xE2;
    CMD_Buf[1]=0xE4;
    CMD_Buf[2]=0x0F;
    CMD_Buf[3]=0x00;
    CMD_Buf[4]=0xFF;
    CMD_Buf[5]=0x01;
    CMD_Buf[6]=0xFE;
    CMD_Buf[7]=0x40;
    CMD_Buf[8]=0x02;
    CMD_Buf[9]=0x03; // COM
    CMD_Buf[10]=0x00; // ARG
    CMD_Buf[11]=0xFF; // CRCL
    CMD_Buf[12]=0xFF; // CRCH

    Cal_Checksum();
    SendCommand();
}

```

Execute MainSource1() of result :

CMD_Buf[0~12] = E2, E4, 0F, 00, FF, 01, FE, 40, 02, 03, 00, CD, 16

Other example :

Main Source 2 = E2, E4, 0F, 00, FF, 01, FE, 40, 02, 03, 01, 0C, D6

Speed 1 := E2, E4, 0F, 00, FF, 01, FE, 40, 02, 20, 00, D4, 26

Mix := E2, E4, 0F, 00, FF, 01, FE, 40, 02, 32, 00, D8, 86

Table 1. Lower CRC byte calculation coefficients.(Hex)

000h 0c1h 081h 040h 001h 0c0h 080h 041h
001h 0c0h 080h 041h 000h 0c1h 081h 040h
001h 0c0h 080h 041h 000h 0c1h 081h 040h
000h 0c1h 081h 040h 001h 0c0h 080h 041h
001h 0c0h 080h 041h 000h 0c1h 081h 040h
000h 0c1h 081h 040h 001h 0c0h 080h 041h
000h 0c1h 081h 040h 001h 0c0h 080h 041h
001h 0c0h 080h 041h 000h 0c1h 081h 040h
001h 0c0h 080h 041h 000h 0c1h 081h 040h
000h 0c1h 081h 040h 001h 0c0h 080h 041h
000h 0c1h 081h 040h 001h 0c0h 080h 041h
001h 0c0h 080h 041h 000h 0c1h 081h 040h
000h 0c1h 081h 040h 001h 0c0h 080h 041h
001h 0c0h 080h 041h 000h 0c1h 081h 040h
000h 0c1h 081h 040h 001h 0c0h 080h 041h
001h 0c0h 080h 041h 000h 0c1h 081h 040h
000h 0c1h 081h 040h 001h 0c0h 080h 041h
001h 0c0h 080h 041h 000h 0c1h 081h 040h
000h 0c1h 081h 040h 001h 0c0h 080h 041h
001h 0c0h 080h 041h 000h 0c1h 081h 040h
000h 0c1h 081h 040h 001h 0c0h 080h 041h
001h 0c0h 080h 041h 000h 0c1h 081h 040h
000h 0c1h 081h 040h 001h 0c0h 080h 041h
001h 0c0h 080h 041h 000h 0c1h 081h 040h
000h 0c1h 081h 040h 001h 0c0h 080h 041h
001h 0c0h 080h 041h 000h 0c1h 081h 040h
000h 0c1h 081h 040h 001h 0c0h 080h 041h
001h 0c0h 080h 041h 000h 0c1h 081h 040h

Table 2. Higher CRC byte calculation coefficients.(Hex)

000h 0c0h 0c1h 001h 0c3h 003h 002h 0c2h
0c6h 006h 007h 0c7h 005h 0c5h 0c4h 004h
0cch 00ch 00dh 0cdh 00fh 0cfh 0ceh 00eh
00ah 0cah 0cbh 00bh 0c9h 009h 008h 0c8h
0d8h 018h 019h 0d9h 01bh 0dbh 0dah 01ah
01eh 0deh 0dfh 01fh 0ddh 01dh 01ch 0dch
014h 0d4h 0d5h 015h 0d7h 017h 016h 0d6h
0d2h 012h 013h 0d3h 011h 0d1h 0d0h 010h
0f0h 030h 031h 0f1h 033h 0f3h 0f2h 032h
036h 0f6h 0f7h 037h 0f5h 035h 034h 0f4h
03ch 0fch 0fdh 03dh 0ffh 03fh 03eh 0feh
0fah 03ah 03bh 0fbh 039h 0f9h 0f8h 038h
028h 0e8h 0e9h 029h 0ebh 02bh 02ah 0eah
0eeh 02eh 02fh 0efh 02dh 0edh 0ech 02ch
0e4h 024h 025h 0e5h 027h 0e7h 0e6h 026h
022h 0e2h 0e3h 023h 0e1h 021h 020h 0e0h
0a0h 060h 061h 0a1h 063h 0a3h 0a2h 062h
066h 0a6h 0a7h 067h 0a5h 065h 064h 0a4h
06ch 0ach 0adh 06dh 0afh 06fh 06eh 0aeh
0aah 06ah 06bh 0abh 069h 0a9h 0a8h 068h
078h 0b8h 0b9h 079h 0bbh 07bh 07ah 0bah
0beh 07eh 07fh 0bfh 07dh 0bdh 0bch 07ch
0b4h 074h 075h 0b5h 077h 0b7h 0b6h 076h
072h 0b2h 0b3h 073h 0b1h 071h 070h 0b0h
050h 090h 091h 051h 093h 053h 052h 092h
096h 056h 057h 097h 055h 095h 094h 054h
09ch 05ch 05dh 09dh 05fh 09fh 09eh 05eh
05ah 09ah 09bh 05bh 099h 059h 058h 098h
088h 048h 049h 089h 04bh 08bh 08ah 04ah
04eh 08eh 08fh 04fh 08dh 04dh 04ch 08ch
044h 084h 085h 045h 087h 047h 046h 086h
082h 042h 043h 083h 041h 081h 080h 040h

Table 3. Command Type

No.	COM (Hex)	ARG (Hex)	Description
1	00	00	Sub source: Set SDI input port 1
		01	Sub source: Set SDI input port 2
		02	Sub source: Set SDI input port 3
		03	Sub source: Set SDI input port 4
		04	Sub source: Set SDI input port 5
2	01	00	Sub source: Set Black Screen
3	02	00	Sub source: Set Colour Bar
4	03	00	Main source: Set SDI input port 1
		01	Main source: Set SDI input port 2
		02	Main source: Set SDI input port 3
		03	Main source: Set SDI input port 4
		04	Main source: Set SDI input port 5
5	04	00	Main source: Set Black Screen
6	05	00	Main source: Set Colour Bar
7	10	00	Logo 1 turn off
		01	Logo 1 turn on
8	11	00	Logo 2 and Clock turn off
		01	Logo 2 turn on
		02	Clock turn on
9	20	00	Auto function : Set Speed as level 1
		01	Auto function : Set Speed as level 2
		02	Auto function : Set Speed as level 3
		03	Auto function : Set Speed as level 4
		04	Auto function : Set Speed as level 5
10	30	00	Wipe Effect Type 1
		01	Wipe Effect Type 2
		02	Wipe Effect Type 3
		03	Wipe Effect Type 4
		04	Wipe Effect Type 5
		05	Wipe Effect Type 6
		08	Wipe Effect Type 1 of Inversion
		09	Wipe Effect Type 2 of Inversion
		0A	Wipe Effect Type 3 of Inversion
		0B	Wipe Effect Type 4 of Inversion
		0C	Wipe Effect Type 5 of Inversion
		0D	Wipe Effect Type 6 of Inversion
		11	31
01	Effect soft border		
12	32	00	Mix function
		01	Wipe function

13	40	00	Cut function
14	41	00	Auto function
15	50	00	PIP source: Set SDI input port 1
		01	PIP source: Set SDI input port 2
		02	PIP source: Set SDI input port 3
		03	PIP source: Set SDI input port 4
		04	PIP source: Set SDI input port 5
16	51	00	PIP display on Sub source
		01	PIP turn off on Sub source
17	52	00	PIP display on Main source
		01	PIP turn off on Main source
18	61	00	Luma disable on Sub source
		01	Luma enable on Sub source
19	62	00	Luma disable on Main source
		01	Luma enable on Main source
20	70	00	Frame Freeze turn off
		01	Frame Freeze turn on
21	80	00	System time read
22	81	Hours (BCD)	System time of Hour adjustment
23	82	Minutes (BCD)	System time of Minute adjustment
24	83	Second (BCD)	System time of Second adjustment
25	90	00	Get device status

Table 4. Response Code

No.1~20, 22, 23, 24														
Byte	1	2	3	4	5	6	7	8	9	10	11			
Data	E2	E3	FF	01	0F	00	FE	C0	00	BE	C0			
No.21														
Byte	1	2	3	4	5	6	7	8	9	10	11	12	13	14
Data	E2	E4	FF	01	0F	00	FE	C0	03	18	22	05	68	C4
Byte 9 : Len =03 Bytes 10,11&12 : System Time = 18:22:05														
No.25														
Byte	1	2	3	4	5	6	7	8	9	10	11	12		
Data	E2	E4	FF	01	0F	00	FE	C0	29	Table5	CRCL	CRCH		

Table 5. Status Code (41 Bytes reference pages 35 & 37)

Byte 1: Current_User_Number	Byte 2: Input A	Byte 3: Input B	Byte 4: PIP_Input
Byte 5: Effect	Byte 6: Speed	Byte 7: Speed_Value_0	Byte 8: Speed_Value_1
Byte 9: Speed_Value_2	Byte 10: Speed_Value_3	Byte 11: Speed_Value_4	Byte 12: Mux_Line_A
Byte 13: Mux_Line_B	Byte 14: Bright_Cur	Byte 15: Contrast_Cur	Byte 16: Saturation_Cur
Byte 17: X_Lbl_1	Byte 18: Y_Lbl_1	Byte 19: X_Lbl_2	Byte 20: Y_Lbl_2
Byte 21: Lbl_1_Number	Byte 22: Lbl_2_Number	Byte 23: X_clock	Byte 24: Y_clock
Byte 25: Background_Number	Byte 26: Brightness_Control	Byte 27: Color_Fill	Byte 28: X_PIP
Byte 29: Y_PIP	Byte 30: PIP_Size	Byte 31: Luma_Key_Level	Byte 32: Sys_Format
Byte 33: Inp_3_Mode	Byte 34: Link_Flags	Byte 35: Link_Flags_Ext	Byte 36: Flags_Mixer
Byte 37: Flags_Line_A	Byte 38: Flags_Line_B	Byte 39: Flags_Sources_Position	Byte 40: Flags_DSK
Byte 41: Flags_Lbl			

Current_User_Number – current user number (0...5), number 0 corresponds to the Master User which other the other users settings and adjustments can be linked to.

Input_A, Input_B, PiP_Input – input number currently switched to the multiplexor's Line A, multiplexor's Line B and PiP shaper input;

Effect – currently set transition effect (curtains):

r FB B1 B0 E3 E2 E1 E0

r- reserved bit,

FB- soft border activation flag(0 – off, 1 – on),

B1, B0- effect border width, 0... 3,

E3 – effect inversion flag(0 – direct, 1 – inverse),

E2, E1, E0- effect number(0... 5);

Speed – number of the pressed key for speed selection (0... 4);

Speed_Value_0, Speed_Value_1, Speed_Value_2, Speed_Value_3, Speed_Value_4 – predefined speed corresponding to the keys for Speed Selection (4... 64);

Mux_Line_A, Mux_Line_B – the multiplexor's Line A and Line B status:

r r r r r M2 M1 M0

r- reserved bits,

M2, M1, M0 – signal source for the Line(000- selected input (**Input_A** or **Input_B**), 001- reserved, 010- Color Bars, 011- Color Fill defined by Color_Fill parameter);

Bright_Cur – brightness of the last selected source (0x48... 0xb8 with step 8);

Contrast_Cur – contrast of the last selected source (0x24... 0x5c with step 4);

Saturation_Cur – color saturation of the last selected source (0x24... 0x5c with step 4);

X_Lbl_1, X_Lbl_2, X_clock – X-coordinate for Logo 1 or Logo 2 or Clock (0... 62 for 1280x720 screen resolution or 0... 102 for 1920x1080 screen resolution);

Y_Lbl_1, Y_Lbl_2, Y_clock – Y-coordinate for Logo 1 or Logo 2 or Clock (0... 130 for 1280x720 screen resolution or 0... 110 for 1920x1080 screen resolution);

Lbl_1_Number – Logo 1 number (0... 13);

Lbl_2_Number – Logo 2 number (0...13);

Background_Number – multiscreen background image number(0...7);

Brightness_Control – keyboard LED brightness factor(0... 1);

Color_Fill – Color Fill number(0... 7);

X_PiP – X-coordinate for PiP (0... 70 for 1280x720 screen resolution or 0... 102 for 1920x1080 screen resolution);

Y_PiP – Y-coordinate for PiP (0... 77 for 1280x720 screen resolution or 0... 113 for 1920x1080 screen resolution);

PiP_Size – PiP size(32... 64);

Luma_Key_Level – Luma Key threshold level(0...255);

Sys_Format – multiscreen resolution (the higher 4 bits) and the output signal system (the lower 4 bits). The following values are valid:

Mon_1920x1080_i60		Out_1920x1080_i25	
Mon_1920x1080_i60		Out_1920x1080_i30	
Mon_1920x1080_i60		Out_1920x1080_i29.95	
Mon_1920x1080_i60		Out_1280x720_p50	
Mon_1920x1080_i60		Out_1280x720_p60	
Mon_1920x1080_i60		Out_1280x720_p59.9	
Mon_1280x720_p60		Out_1920x1080_i25	
Mon_1280x720_p60		Out_1920x1080_i30	
Mon_1280x720_p60		Out_1920x1080_i29.95	
Mon_1280x720_p60		Out_1280x720_p50	
Mon_1280x720_p60		Out_1280x720_p60	
Mon_1280x720_p60		Out_1280x720_p59.9	
Mon_1920x1080_i60	= 0	Out_1920x1080_i25	= 0
Mon_1280x720_p60	= 1	Out_1920x1080_i30	= 1
		Out_1920x1080_i29.95	= 2
		Out_1280x720_p50	= 3
		Out_1280x720_p60	= 4
		Out_1280x720_p59.9	= 5

Inp_3_Mode – the current input 3 mode, 0 – SDI, 1 – DVI;

Link_Flags – Master user settings link flags, it may be unlinked(value 0) or linked(value 1) to the corresponding basic parameter:

- bit 7 – input 0 settings link flag (brightness, contrast, saturation),
- bit 6 – input 1 settings link flag (brightness, contrast, saturation),
- bit 5 – input 2 settings link flag (brightness, contrast, saturation),
- bit 4 – input 3 settings link flag (brightness, contrast, saturation),
- bit 3 – input 4 settings link flag (brightness, contrast, saturation),
- bit 2 – position and numbers of the Logo 1, Logo 2 and Clock position link flag,
- bit 1 – PiP position and size link flag,
- bit 0 – input 3 mode link flag;

Link_Flags_Ext – Master User settings extended flags, it may be unlinked (value 0) or linked (value 1) to the corresponding basic parameter:

- bit 7 – output signal system link flag,
- bit 6 – multiscreen resolution link flag,
- bit 5 – Luma Key threshold level link flag,
- bits 4... 0 reserved, ignore;

Flags_Mixer – switching flags (mixing):

- bit 7 – Line connected to Program output (Main Source), 0 – Line A, 1 – Line B,
- bit 6 – reserved, ignore,
- bit 5 – reserved, ignore,
- bit 4 – switch mode, 0 – mixing, 1 – curtains,
- bits 3... 0 reserved, ignore;

Flags_Line_A, Flags_Line_B – Frame freeze flags of Line A and Line B:

- bit 7 – 0 - Frame freeze off, 1 - Frame freeze on
- bits 6... 0 – reserved, ignore;

Flags_Sources_Position – Selection Key inversion flags and switcher's T-bar mode flag:

- bit 7 – 0 – keyboard's source Selection Keys are arranged in direct manner (Source 1 is on the left), 1 – inverse manner (Bar is on the left),
- bit 6 – 0 – T-bar is active only while moving upwards, 1 – T-bar is active while moving both upwards and downwards,
- bits 5... 0 reserved, ignore;

Flags_DSK – PiP and Luma Key out flags:

- bit 7... 6 – reserved, ignore,
- bit 5 – 1 – Luma Key is output onto Preview channel, 0 – not,
- bit 4 – 1 – Luma Key is output onto Program channel, 0 – not,
- bit 3 – 1 – PiP is output onto Preview channel, 0 – not,
- bit 2 – 1 – PiP is output onto Program channel, 0 – not,
- bits 1... 0 – reserved, ignore;

Flags_Lbl – Logo and Clock activation flags:

- bit 7 – 1 – Logo 1 is output onto Program channel, 0 – not,
- bit 6 – 1 – Logo 2 is output onto Program channel, 0 – not,
- bit 5 – 1 – Logo 1 is output onto Preview channel, 0 – not,
- bit 4 – 1 – Logo 2 is output onto Preview channel, 0 – not,
- bit 3 – Clock activation instead of Logo 2 (0- Logo 2, 1- Clock),
- bits 2... 0 – reserved, ignore;

1.26. **COM** = 0xA0 – copy and write setting parameters **Common_Settings** (Section 2) from the device's EEPROM into the device's volatile memory. **ARG** = 0. Device replies with **LEN** = 0, **ANSW** is not available.

1.27. **COM** = 0xA0 – device soft reset. **ARG** = 0. Device replies with **LEN** = 0, **ANSW** is not available. The device executes soft reset and it completely reboots (similar to the power recycle). It is impossible to establish a connection with the device for around 8 seconds.

Optional Datavideo Accessory Items for the SE-2000

Datavideo have a number of accessory products which will allow you to get the most from your new SE-2000. Please speak to your local dealer or visit the website for your local Datavideo office for more details on these and other products.

HD / SD 17.3" Widescreen LCD TFT Monitor Series

TLM-170H



Desktop

TLM-170HR



7U rack mount

TLM-170HM



1U mobile tray rack mount



TLM-700HD

7" HD-SDI /HDMI /HD YUV monitor
IDX Battery or Mains powered



Audio Delay Box
AD-100



HD-SDI Recorder

HDR-40 / HDR-50
With removable 2.5" SATA drive



DAC-9

Tripod mounted
HDMI to HD-SDI converter



ITC-100

8 Way Intercom / Talkback System
with Tally lights

Communicate with up to 8 camera
operators from one base unit.



TB-5

4 Way Tally Light System

Specifications

Inputs	<ul style="list-style-type: none"> • 4x BNC connector for HD -SDI input • 2x DVI connector for DVI-D input (1x DVI-D input is collective with SDI#4 channel)
Outputs	<ul style="list-style-type: none"> • 2x HD-SDI output, 1x HD-YUV output, and 1x DVI-D output • Video delay through the mixer 1 Frame or less • Audio delay through the mixer less than 1 Frame
Video Input	<ul style="list-style-type: none"> • HD (1080/50i - 1080/60i - 1080/59.94i - 720/50p - 720/60p - 720/59.94p)
Preview output	<ul style="list-style-type: none"> • 1x DVI-D output • Multi screen display in PVW output: • PVW output include 6x monitoring screen and 1x PVW screen and 1x PGM screen • Resolution is 1280 x 1024
Other Interface	<ul style="list-style-type: none"> • Serial (Editor) D-Sub 9 Pin x 1 RS232 • Tally Output D-Sub 15 Pin x 1 14 Channel Open Collector Output • 4 x XLR balance audio input separate channel, 2 x XLR balance audio output. • Support Line and MIC mode
HD SDI signal	<ul style="list-style-type: none"> • SMPTE 292M standard complied with • Output return loss : More than 15 dB (5MHz to 750MHz) More than 10 dB (750MHz to 1.5 GHz) • Output level : 0.8 Vpp \pm 10% • Rise time : Less than 270 ps • Fall time : Less than 270 ps • Difference between rise time and fall time within 100 ps • Alignment jitter : Less than 0.2 UI • Timing jitter : Less than 1.0 UI • Eye aperture ratio : More than 90% • DC offset : 0 \pm 0.5V • Equalizer use 5C-FB cable support 100 meters
HD-YUV Output	<ul style="list-style-type: none"> • Bandwidth 30MHz < +/- 3dB • S/N Ratio > 50 dB • DG <3 degree, DP <3% (Base on U, V signal analyze)
Audio	<ul style="list-style-type: none"> • Bandwidth 20~20KHz < +/- 3dB • S/N Ratio > 70 dB • THD. < 0.1%
Audio Mixer	<ul style="list-style-type: none"> • 4 Channel audio input mixer (balanced audio) • Line mode/MIC mode selectable • 2 Channel audio output, balanced audio
IRE	<ul style="list-style-type: none"> • 0 - 7.5 IRE Options (NTSC Only)
Operating Temperature	<ul style="list-style-type: none"> • 0°C to 40°C (32°F to 102°F)
Humidity	<ul style="list-style-type: none"> • 10% to 90% (non condensing)
Dimension & Weight	<ul style="list-style-type: none"> • 425mm (W) x 400mm (D) x 96mm (H) / 8.8 lbs / 4Kgs
Power	<ul style="list-style-type: none"> • Input AC 100 ~ 240V Switching Adaptor, output DC 12V / 5A

Service and Support

It is our goal to make your products ownership a satisfying experience. Our supporting staff is available to assist you in setting up and operating your system. Please refer to our web site www.datavideo-tek.com for answers to common questions, support requests or contact your local office below.

Datavideo Global Website: www.datavideo-tek.com

Datavideo Corporation

Tel: +1 562 696 2324	Fax: +1 562-698-6930	E-Mail: contactus@datavideo.us
----------------------	----------------------	--

Datavideo Technologies Europe BV

Tel: +31-30-261-96-56	Fax: +31-30 261-96-57	E-Mail: service@datavideo.nl
-----------------------	-----------------------	--

Datavideo UK Limited

Tel: +44 1457 851 000	Fax: +44 1457 850 964	E-Mail: sales@datavideo.co.uk
-----------------------	-----------------------	--

Datavideo Technologies Co., Ltd

Tel: +886 2 8227 2888	Fax: +886-2-8227-2777	E-mail: service@datavideo.com.tw
-----------------------	-----------------------	--

Datavideo Technologies China Co., Ltd

Tel: +86 21-5603 6599	Fax: +86 21-5603 6770	E-mail: service@datavideo.cn
-----------------------	-----------------------	--

Datavideo Technologies (S) PTE Ltd

Tel: +65-6749 6866	Fax: +65-6749 3266	E-mail: sales@datavideo.sg
--------------------	--------------------	--

Datavideo HK Ltd

Tel: +852 2833 1981	Fax: +852-2833-9916	E-mail: info@datavideo.com.hk
---------------------	---------------------	--

All the trademarks are the properties of their respective owners.

Datavideo Technologies Co., Ltd. All rights reserved 2012