

Panasonic®

Model No.
TH-32LRG20E

Operating Instructions LCD Television



VIERA



Thank you for purchasing this Panasonic product.
Please read these instructions carefully before operating this product and retain them for future reference.
The images shown in this manual are for illustrative purposes only.
Please refer to Pan European Guarantee Card if you need to contact your local Panasonic dealer for assistance.

English



TQB0E0986U-1

Experience an amazing level of multimedia excitement

Enjoy rich multimedia

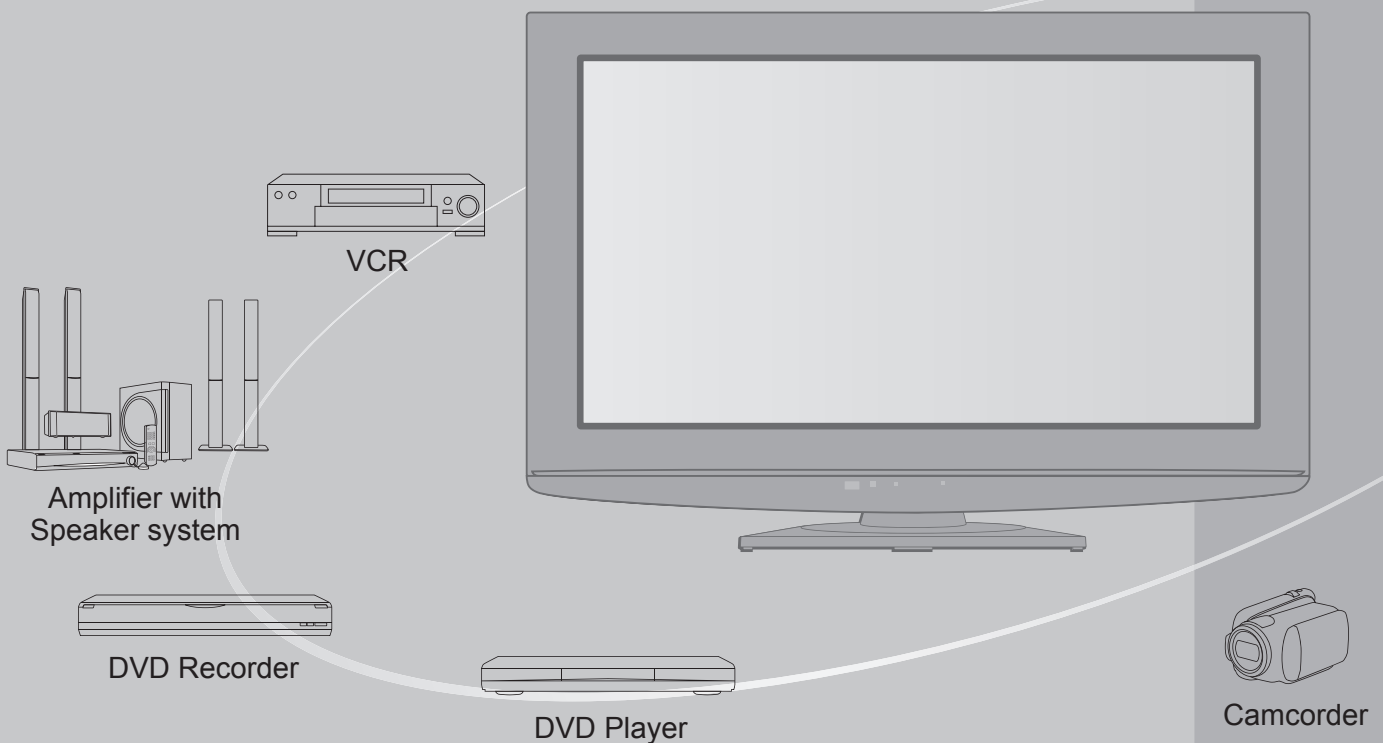

Notice for DVB functions

This TV is designed to meet the standards (current as of August, 2009) of DVB-T (MPEG2 and MPEG4-AVC(H.264)) digital terrestrial services and DVB-C (MPEG2 and MPEG4-AVC(H.264)) digital cable services.

Consult your local dealer for availability of DVB-T services in your area.

Consult your cable service provider for availability of DVB-C services with this TV.

- This TV may not work correctly with the signal which does not meet the standards of DVB-T or DVB-C.
- Not all the features are available depending on the country, area, broadcaster and service provider.
- Not all CI modules work properly with this TV. Consult your service provider about the available CI module.
- This TV may not work correctly with CI module that is not approved by the service provider.
- Additional fees may be charged depending on the service provider.
- The compatibility with future DVB services is not guaranteed.
- Check the latest information on the available services at the following website. (English only)
<http://panasonic.jp/support/global/cs/>

Contents

Be Sure to Read

- Safety Precautions (Warning / Caution) 4
- Maintenance 5

Quick Start Guide

- Accessories / Options 6
- Identifying Controls 8
- Basic Connection 10
- Auto Setup 12

Quick Start Guide

Enjoy your TV!

Basic Features

- Watching TV 14
- Using TV Guide 18
- Viewing Teletext 20
- Watching External inputs 22
- How to Use VIERA TOOLS 24
- How to Use Menu Functions 25

Basic

Advanced Features

- Retuning from Setup Menu 32
- Tuning and Editing Channels (DVB) 34
- Tuning and Editing Channels (Analogue) 36
- Timer Programming 38
- Child Lock 40
- Input Labels 41
- Using Common Interface 42
- Shipping Condition 43
- Updating the TV Software 44
- Displaying PC Screen on TV 45
- Using Media Player 46
- Link Functions 50
(Q-Link / VIERA Link)
- External Equipment 58

Advanced

FAQs, etc.

- Technical Information 60
- FAQs 65
- Specifications 67
- Licence 68

FAQs, etc.



SD Card

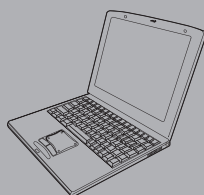

Personal computer

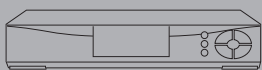

Set top box

This product is licensed under the AVC patent portfolio license for the personal and non-commercial use of a consumer to (i) encode video in compliance with the AVC Standard ("AVC Video") and/or (ii) decode AVC Video that was encoded by a consumer engaged in a personal and non-commercial activity and/or was obtained from a video provider licensed to provide AVC Video. No license is granted or shall be implied for any other use. Additional information may be obtained from MPEG LA, LLC. See <http://www.mpegla.com>.

GEMSTAR-TV GUIDE INTERNATIONAL, INC. AND/OR ITS RELATED AFFILIATES ARE NOT IN ANY WAY LIABLE FOR THE ACCURACY OF THE PROGRAM SCHEDULE INFORMATION PROVIDED BY THE GUIDE PLUS+ SYSTEM. IN NO EVENT SHALL GEMSTAR-TV GUIDE INTERNATIONAL, INC. AND/OR ITS RELATED AFFILIATES BE LIABLE FOR ANY AMOUNTS REPRESENTING LOSS OF PROFITS, LOSS OF BUSINESS, OR INDIRECT, SPECIAL, OR CONSEQUENTIAL DAMAGES IN CONNECTION WITH THE PROVISION OR USE OF ANY INFORMATION, EQUIPMENT, OR SERVICES RELATING TO THE GUIDE PLUS+ SYSTEM.

<http://www.europe.guideplus.com/>

Safety Precautions

Warning

Handling the mains plug and lead

- Insert the mains plug fully in to the socket outlet. (If the mains plug is loose, it could generate heat and cause fire.)
- Ensure that the mains plug is easily accessible.
- Do not touch the mains plug with a wet hand. This may cause an electrical shock.
- Do not damage the mains lead, damaged lead may cause fire or electrical shock.
 - Do not move the TV with the lead plugged in to a socket outlet.
 - Do not place a heavy object on the lead or place the lead near a high temperature object.
 - Do not twist the lead, bend it excessively or stretch it.
 - Do not pull on the lead. Hold on to the mains plug body when disconnecting the plug.
 - Do not use a damaged mains plug or socket outlet.
 - Ensure TV does not crush the mains lead.

If you find any abnormality, remove the mains plug immediately!

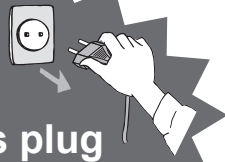

**AC 220-240V
50Hz**



Power source

- This TV is designed to operate on 220-240V 50Hz AC.

Do not remove covers and NEVER modify the TV yourself

- High voltage components may cause serious electrical shock, do not remove the rear cover as live parts are accessible when it is removed.
- There are no user serviceable parts inside.
- Have the TV checked, adjusted or repaired at your local Panasonic dealer.

Do not expose to rain or excessive moisture

- To prevent damage which might result in electric shock or fire, do not expose this TV set to rain or excessive moisture.
- This TV must not be exposed to dripping or splashing water and objects filled with liquid, such as vases, must not be placed on top of or above the TV.

Do not expose the TV set to direct sunlight and other sources of heat

- Avoid exposing the TV to direct sunlight and other sources of heat.

To prevent the spread of fire, keep candles or other open flames away from this product at all times



Do not place foreign objects inside the TV

- Do not allow any objects to drop into the TV through the air vents as fire or electric shock may result.

Do not place TV on unstable surfaces

- The TV may fall or tip over.

Use only original dedicated pedestal / mounting equipment

- Using an unapproved pedestal or other fixtures may make the TV unstable, risking injury. Be sure to ask your local Panasonic dealer to perform the set up or installation.
- Use approved pedestals / wall-hanging brackets (p. 6 – 7).

Do not allow children to handle SD Card or dangerous parts

- As with any small object the SD card could be swallowed by young children. Please remove SD card immediately after use and store out of reach of children.
- This product contains possibly dangerous parts that can be breathed in or swallowed by young children accidentally. Keep these parts out of reach of young children.

Caution

■ When cleaning the TV remove the mains plug

- Cleaning an energized TV may cause electric shock.

■ Remove the mains plug from the wall socket when TV is not in use for a prolonged period of time

- The TV will still consume some power even in the off mode, as long as the mains plug is still connected.
- Remove the mains plug from the wall socket before connecting or disconnecting leads.

■ Do Not block the rear air vents

- Adequate ventilation is essential to prevent failure of electronic components.
- Ventilation should not be impeded by covering the ventilation openings with items such as newspapers, table cloths and curtains.
- We recommend that a gap of at least 10 cm is left all around this television receiver even when placed inside a cabinet or between shelves.
- When using the pedestal, keep the space between the bottom of the TV and the surface where the TV is set.
- If pedestal is not used, ensure the vents in the bottom of the TV set are not blocked.

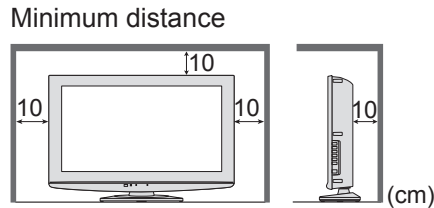

■ Do not apply strong force or impact to the display panel

- This may cause damage resulting in injury.

■ Do not expose your ears to excessive volume from the headphones

- Irreversible damage can be caused.

■ Auto power standby function

- If no signal is received and no operation is performed in analogue TV mode for 30 minutes, the TV will automatically go to standby mode.

■ Transport TV set in upright position

Maintenance

First, remove the mains plug from the socket outlet.

Display panel, Cabinet, Pedestal

Regular care:

Gently wipe the surface of the display panel, cabinet, or pedestal by using a soft cloth to clean the dirt or fingerprints.

For stubborn dirt:

Dampen a soft cloth with clean water or diluted neutral detergent (1 part detergent to 100 parts water). Then wring the cloth and wipe the surface. Finally, wipe away all the moisture.

Caution

- Do not use a hard cloth or rub the surface too hard. This may cause scratches on the surface.
- Take care not to subject the TV's surfaces to water or detergent. A liquid inside the TV could lead to product failure.
- Take care not to subject the surfaces to insect repellent, solvent, thinner or other volatile substances. This may degrade surface quality or cause peeling of the paint.
- Take care not to tap or scratch the surface with your fingernail or other hard objects.
- Do not allow the cabinet and pedestal to make contact with a rubber or PVC substance for a long time. This may degrade surface quality.

Mains plug

Wipe the mains plug with a dry cloth at regular intervals. Moisture and dust may lead to fire or electrical shock.

Accessories / Options

Standard accessories

- Remote Control
 - N2QAYB000487



- Operating Instructions
- Pan European Guarantee Card

Check that you have the accessories and items shown

- Batteries for the Remote Control (2)
 - R6 (UM3)



- Pedestal (p. 7)

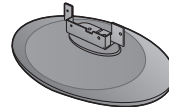

- M3 Serial cable

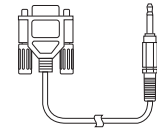

- Assembly screw for Pedestal (4)

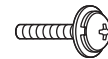

M4

Optional accessories

Wall-hanging bracket

- TY-WK3L2RW

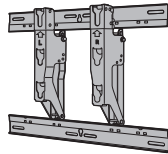

Please contact your nearest Panasonic dealer to purchase the recommended wall-hanging bracket. For additional details, please refer to the wall-hanging bracket installation manual.

Rear of the TV

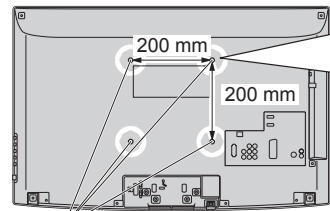

Holes for wall-hanging bracket installation

Screw for fixing the TV onto the wall-hanging bracket (not supplied with the TV)

Depth of screw: minimum 9 mm, maximum 12 mm

(View from the side)

WARNING!

- Failure to use a Panasonic bracket or choosing to mount the unit yourself will be done at the risk of the consumer. Always be sure to ask a qualified technician to carry out set up. Incorrect fitting may cause equipment to fall, resulting in injury and product damage. Any damage resulting from not having a professional installer mount your unit will void your warranty.
- When any optional accessories or wall hanging brackets are used, always ensure that the instructions provided are followed fully.
- Do not mount the unit directly below ceiling lights (such as spotlights or halogen lights) which typically give off high heat. Doing so may warp or damage plastic cabinet parts.
- Take care when fixing wall brackets to the wall. Wall mounted equipment shall not be grounded by metal within the wall. Always ensure that there are no electrical cables or pipes in the wall before hanging bracket.
- To prevent fall and injury, remove TV from its fixed wall position when no longer in use.

Installing / removing remote's batteries

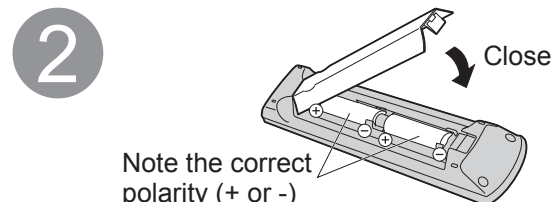
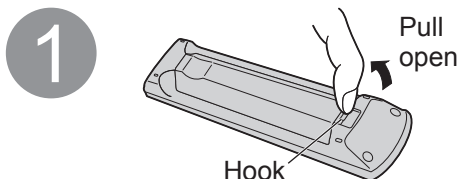

Caution

- Incorrect installation may cause battery leakage and corrosion, resulting in damage to the remote control.
- Do not mix old and new batteries.
- Replace only with same or equivalent type. Do not mix different battery types (such as alkaline and manganese batteries).
- Do not use rechargeable (Ni-Cd) batteries.
- Do not burn or break up batteries.
- Do not expose batteries to excessive heat such as sunshine, fire or the like.
- Make sure you dispose of batteries correctly.
- Ensure batteries are replaced correctly, there is danger of explosion and fire if battery is reversed.

Attaching the pedestal

Warning

Do not disassemble or modify the pedestal.

- Otherwise the TV may fall over and become damaged, and personal injury may result.

Caution

Do not use any other TV and displays.

- Otherwise the TV may fall over and become damaged, and personal injury may result.

Do not use the pedestal if it becomes warped or physically damaged.

- If you use the pedestal while it is physically damaged, personal injury may result. Contact your nearest Panasonic dealer immediately.

During assembly, use only screws supplied and make sure that all screws are securely tightened.

- If sufficient care is not taken to ensure screws are properly tightened during assembly, the pedestal will not be strong enough to support the TV. It might fall over and become damaged and personal injury may result.

Ensure that the TV does not fall over.

- If the TV is knocked or children climb onto the pedestal with the TV installed, the TV may fall over and personal injury may result.

Two or more people are required to install and remove TV.

- If two or more people are not present, the TV may be dropped, and personal injury may result.

Ⓐ Assembly screw (4)

- XSS4+16FNK



Ⓑ Assembly screw (4)

- XYN4+F12FJK



Ⓒ Bracket (1)

- TUX0E197



Ⓓ Base (1)

- TBL0E0108

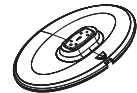

■ Assembling the pedestal

Use the four assembly screws Ⓐ to fasten the bracket

Ⓒ to the base securely.

- Make sure that the screws are securely tightened.

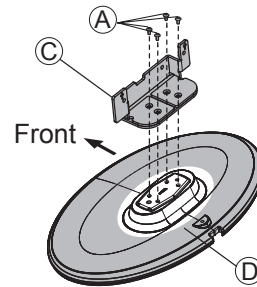

■ Securing the TV

Use only the supplied assembly screws Ⓑ to fasten securely.

- Make sure that the screws are securely tightened.
- Carry out the work on a horizontal and level surface.

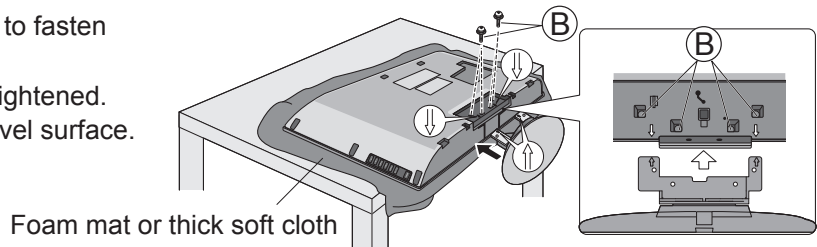

Identifying Controls

Remote Control

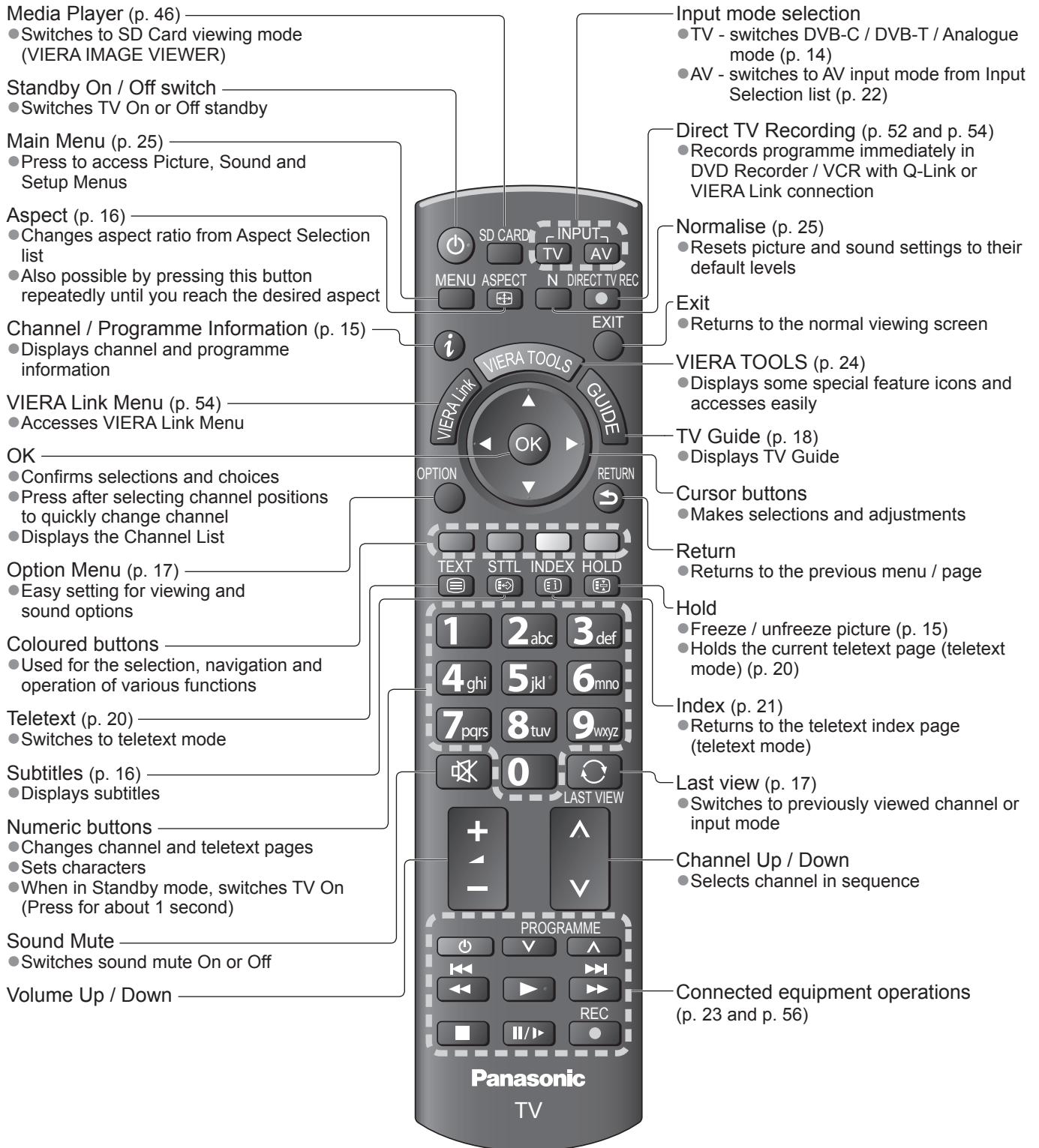

TV

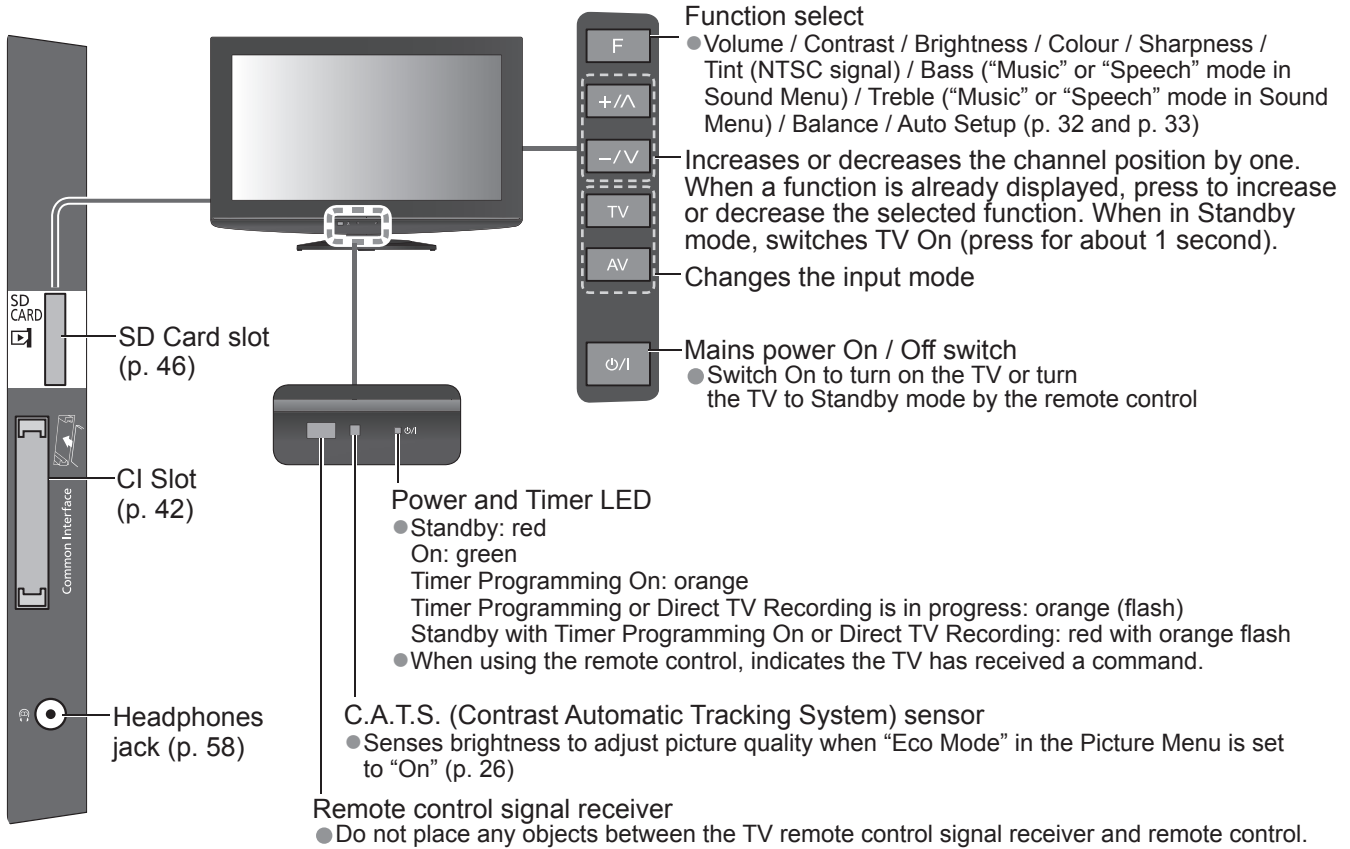

Using the On Screen Displays

Many features available on this TV can be accessed via the On Screen Display menu.

■ How to use remote control



Move the cursor / select the menu item



Move the cursor / adjust levels / select from a range of options



Access the menu / store settings after adjustments have been made or options have been set



Return to the previous menu



Open the main menu



Exit the menu system and return to the normal viewing screen

■ ON SCREEN HELP Instructions box - Operation guide

Example (Sound Menu):

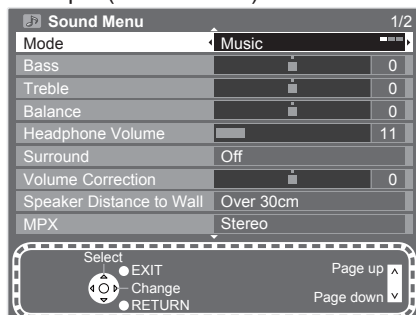

Operation guide will help you.

Basic Connection

External equipment and cables shown are not supplied with this TV.
Please ensure that the unit is disconnected from the mains socket before attaching or disconnecting any leads.

Example 1 Connecting aerial

TV only

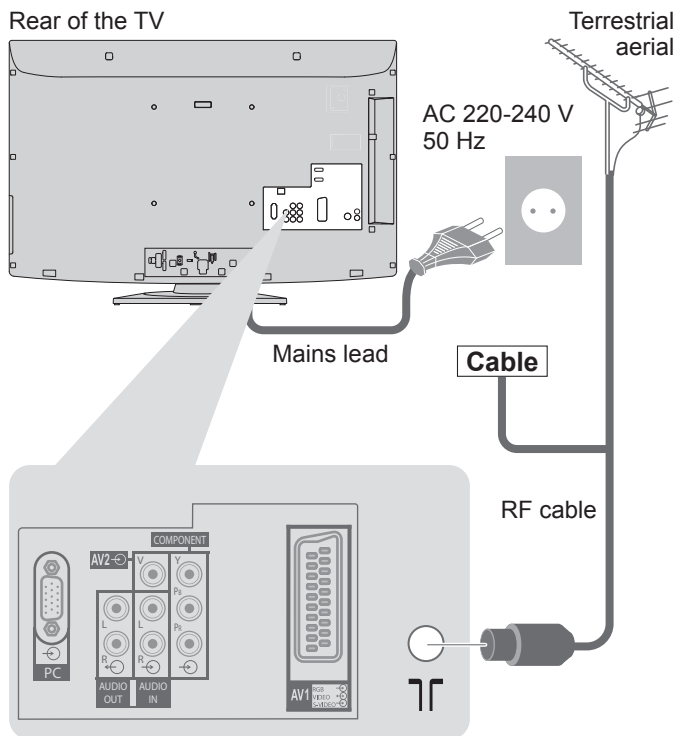

Example 2 Connecting DVD Recorder / VCR

TV, DVD Recorder or VCR

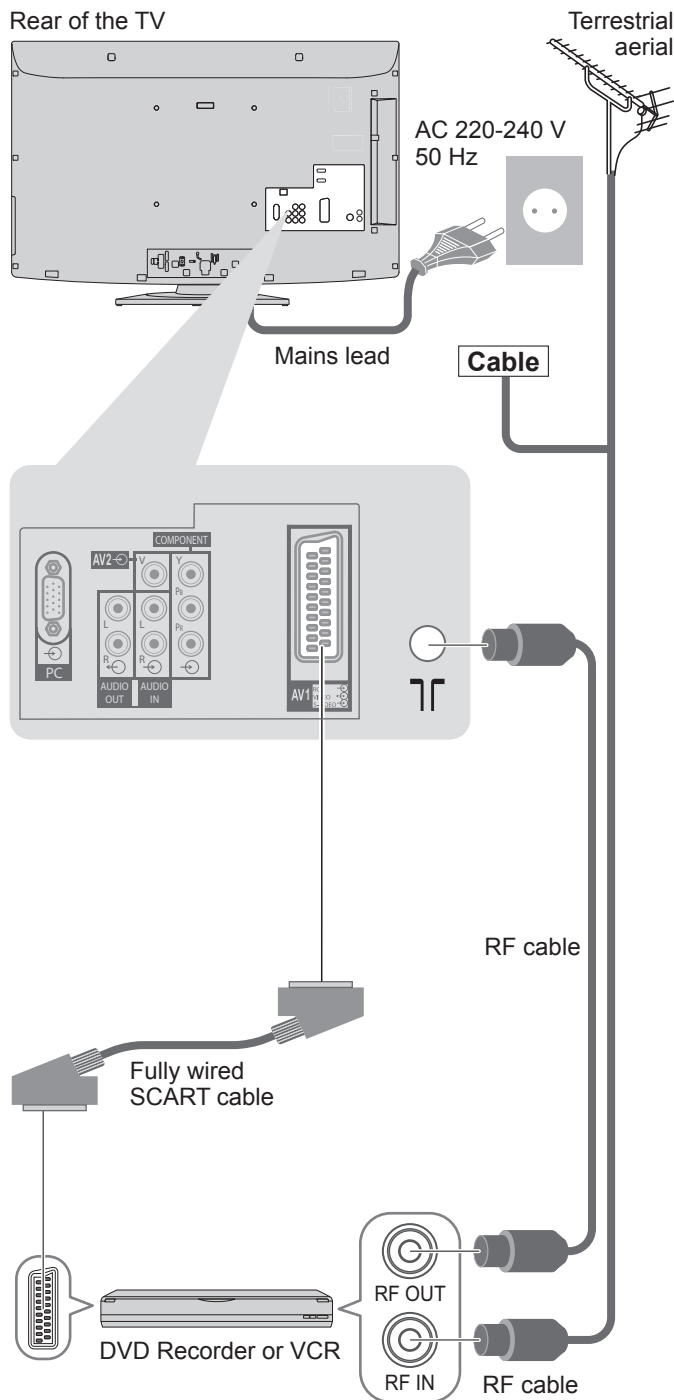

Note

- Connect to the TV's AV1 for a DVD Recorder / VCR supporting Q-Link (p. 52).
- For HDMI-compatible equipment, possible to connect to HDMI terminals (HDMI1 / HDMI2) by using HDMI cable (p. 59).
- Q-Link connection → p. 50
- VIERA Link connection → p. 50 and p. 51
- Please also read the manual of the equipment being connected.

Example 3 Connecting DVD Recorder / VCR and Set top box

TV, DVD Recorder / VCR and Set top box

Rear of the TV

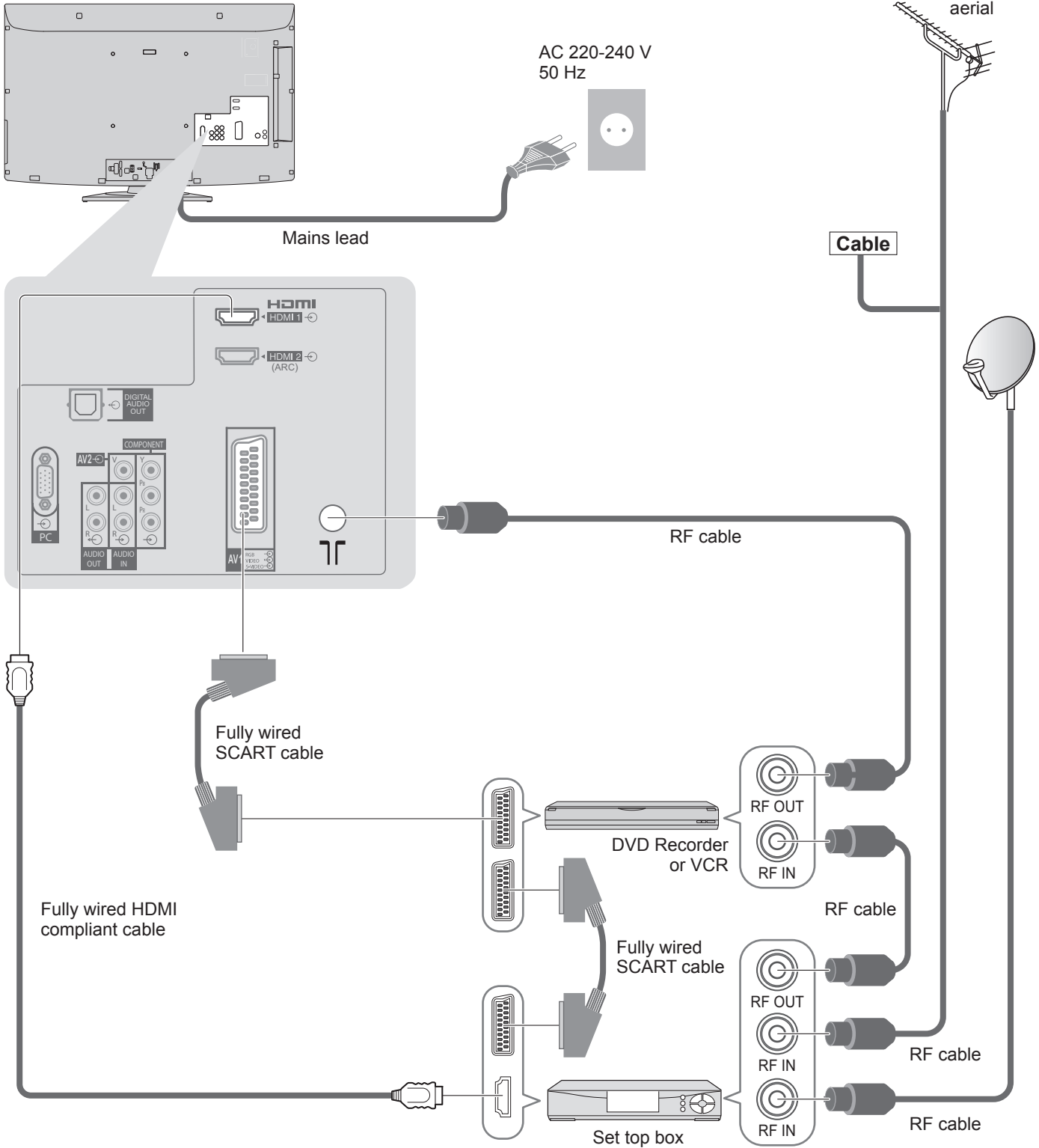

Auto Setup

Search and store TV channels automatically.

- These steps are not necessary if the setup has been completed by your local dealer.
- Please complete connections (p. 10 and p. 11) and settings (if necessary) of the connected equipment before starting Auto Setup. For details of settings for the connected equipment, read the manual of the equipment.



1

Plug the TV into mains socket and switch On (Takes a few seconds to be displayed)



2

Select the language

Menüsprache			
Deutsch	Dansk	Polski	Srpski
English	Svenska	čeština	Hrvatski
Français	Norsk	Magyar	Slovenščina
Italiano	Suomi	Slovenčina	Latviešu
Español	Türkçe	Български	eesti keel
Português	Ελληνικό	Română	Lietuvių
Nederlands			

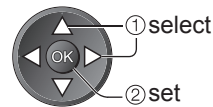

3

Select your country

Country		
Germany	Denmark	Poland
Austria	Sweden	Czech
France	Norway	Hungary
Italy	Finland	Slovakia
Spain	Luxembourg	Slovenia
Portugal	Belgium	Estonia
Switzerland	Netherlands	Lithuania
Malta	Turkey	Others
Andorra	Greece	

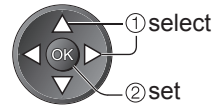

- Depending on the country you select, you may be required to select the Region. In this case, select your region.

4

Select the mode you want to tune

TV Signal Selection	
<input checked="" type="checkbox"/>	DVB-C
<input checked="" type="checkbox"/>	DVB-T
<input checked="" type="checkbox"/>	DVB-T support for HD services
<input checked="" type="checkbox"/>	Analogue
Start Auto Setup	

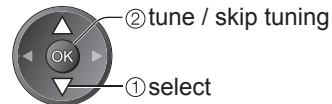

- : tune (the mode will be tuned and searched for the available channels)
- : skip tuning

- “DVB-C” may not appear depending on the country you select (p. 67).

5

Select “Start Auto Setup”

TV Signal Selection	
<input checked="" type="checkbox"/>	DVB-C
<input checked="" type="checkbox"/>	DVB-T
<input checked="" type="checkbox"/>	DVB-T support for HD services
<input checked="" type="checkbox"/>	Analogue
Start Auto Setup	

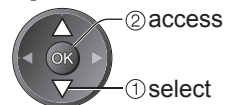

Auto Setup starts

- Auto Setup will start to search for TV channels and store them. The stored channels and sorted channel order vary depending on the country, area, broadcasting system and conditions of signal reception.
- If tuning has failed, check the connection of the RF cable, and then, follow the on screen instructions.

Auto Setup varies depending on the country you select.

● **DVB-C Network Settings**

Enter the Home Frequency and Network ID specified by your cable provider. And then, select "Start Auto Setup".

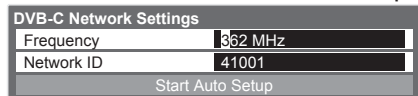

① enter the frequency and network ID



Depending on the country you select, "Auto" is displayed and you do not have to enter them. In this case, Home Frequency and Network ID will be set automatically.

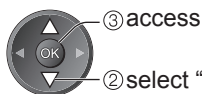

● **DVB-C Auto Setup**

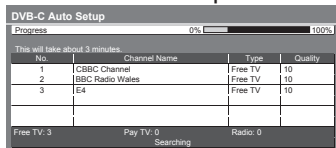

● **DVB-T Auto Setup**

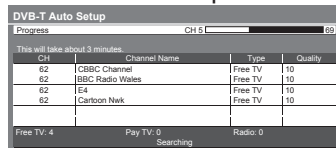

● **Analogue Auto Setup**

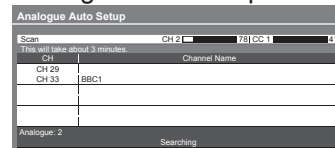

Depending on the country you select, the channel selection screen will be displayed after DVB-T Auto Setup if multiple channels have the same logical channel number. Select your preferred channel or exit the screen for automatic selections.

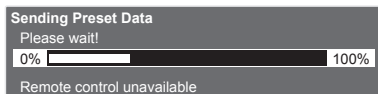

- If Q-Link, VIERA Link or similar technology (p. 52 and p. 53) compatible recorder is connected, channel, language, country / region settings are automatically downloaded to the recorder.
- If downloading has failed, you can download later by the menu item. ➔ "Download" (p. 28)

6 Select "Home"

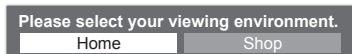

- Select "Home" viewing environment to use in your home environment.

Auto Setup is now complete and your TV is ready for viewing.

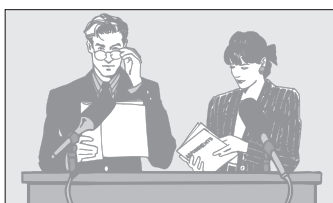

- To check channel list at-a-glance ➔ "Using TV Guide" (p. 18)
- To edit or hide (skip) channels ➔ "Tuning and Editing Channels" (p. 34 - 37)

■ "Shop" viewing environment (for shop display only)

"Shop" viewing environment is the demonstration mode to explain main features of this TV.

Select "Home" viewing environment to use in your home environment.

- You can return to viewing environment selection screen at the stage of Shop confirmation screen and Automatic Demo Off / On selection screen.

① Return to viewing environment selection screen



② Select "Home"



Auto Setup is complete

- To change viewing environment later on, you will need to initialise all settings by accessing Shipping Condition. ➔ "Shipping Condition" (p. 43)

Note

- If tuning has failed or to retune all channels ➔ "Auto Setup" (p. 32 and p. 33)
- To add the available TV mode later ➔ "Add TV Signal" (p. 29)
- To initialise all settings ➔ "Shipping Condition" (p. 43)
- If you turned the TV Off during Standby mode last time, the TV will be in Standby mode when you turn the TV On with Mains power On / Off switch.

Watching TV

1 Turn power on
(Press for about 1 second)



- Mains power On / Off switch should be On. (p. 9)

2 Select the mode





- The selectable modes vary depending on the stored channels (p. 12).
- If "TV Selection" menu is not displayed, press the TV button to switch the mode.

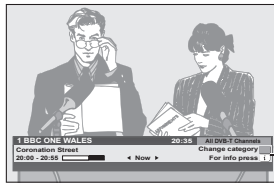

Information banner appears whenever you select a channel
● For details → p. 15

● Also possible to select the mode pressing the TV button repeatedly on the remote control or side panel of the TV. (p. 9)

3 Select a channel



Volume

or



- To select a more than two-digit channel position number, e.g. 399
→ 3 def → 9 wwy → 9 wwy

■ To select from the Channel List

→ OK →

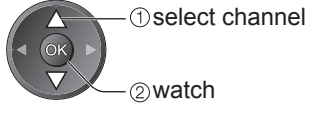
- To change the category → red
- To sort channel names in alphabetical order → blue

Note

- To watch pay-TV
→ "Using Common Interface" (p. 42)

■ Select a channel using Information banner (p. 15)

Possible to confirm the channel name and programme before changing channels.
Display Information banner if it is not displayed

While the banner is displayed, select the channel



● Possible to set display timeout in "Banner Display Timeout" (p. 30).

■ Select a channel using TV Guide (p. 18)

Possible to confirm the TV Guide (EPG) before changing channels.

Display TV Guide

Select the current programme or channel

Select "View" (DVB mode)





● To use Timer Programming → p. 19

■ Other useful functions

Hold

Freeze / unfreeze picture



Display Information banner

Display Information banner

● Also appears when changing a channel

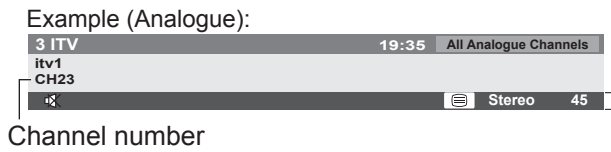
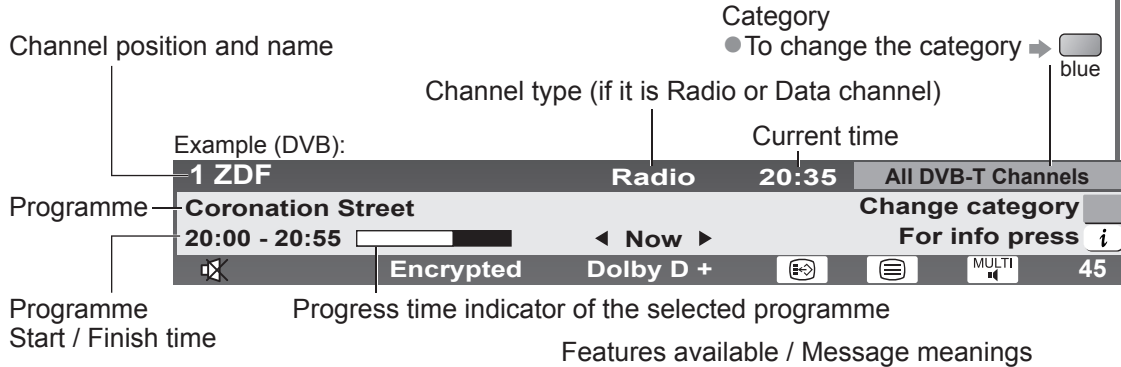

- To confirm another tuned channel name →
- To watch the channel listed in the banner →
- Information on the next programme (DVB) →
- To hide →
- Extra information → (press again to hide the banner)
- To set display timeout → "Banner Display Timeout" (p. 30)

- Sound mute On
- Bad signal**
Poor TV signal quality
- Encrypted**
Scrambled programme
- Dolby D +, Dolby D**
Dolby Digital Plus or Dolby Digital audio track
- Subtitle service available
- Teletext service available
- Multiple audio available
- Multiple video available
- Multiple audio and video available
- Stereo, Mono**
Audio mode
- 1 - 90**
Off Timer remaining time
● For settings → p. 17

Watching TV

Display subtitles

Display / hide subtitles (if available)

- To change the language for DVB (if available)
 - ➔ “Preferred Subtitles” (p. 30)



Note

- If you press the STTL button in Analogue mode, it switches to teletext service and calls up a favourite page (p. 21). Press the EXIT button to return to TV mode.

Aspect

Change the aspect ratio (image size)



Enjoy viewing the image at its optimum size and aspect.

Normally programmes have the Aspect Control Signal (Widescreen signal, etc.), and the TV will choose the aspect ratio automatically according to the Aspect Control Signal (p. 60).

■ If you would like to change the aspect ratio manually

Display Aspect Selection list

While the list is displayed, select the mode

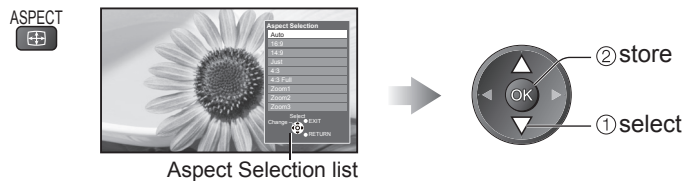

Aspect Selection list

- To change the mode using the ASPECT button only

➔ ASPECT (Press repeatedly until you reach the desired mode)

Auto



The best ratio is chosen and the image expanded to fill the screen.
For details ➔ p. 60

16:9



Directly displays the image at 16:9 without distortion (anamorphic).

4:3 Full



Displays a 4:3 image enlarged horizontally to fit the screen.
● HD signal only

14:9



Displays the image at the standard 14:9 without distortion.

Zoom1



Displays a 16:9 letterbox or 4:3 image without distortion.

Just



Displays a 4:3 image full-screen. Stretching is only noticeable at the left and right edges.

Zoom2



Displays a 16:9 letterbox (anamorphic) image full-screen without distortion.

4:3



Displays the image at the standard 4:3 without distortion.

Zoom3



Displays a 2.35:1 letterbox (anamorphic) image full-screen without distortion. At 16:9, displays the image at its maximum (with slight enlargement).

Note

- Only “16:9” and “4:3” are available in PC input mode.
- Aspect is fixed to “16:9” when “Viewing Mode” is set to “Game” in the Picture Menu.
- Not available when the subtitle function is active.
- Not available in teletext service.
- Aspect mode can be memorized separately for SD (Standard definition) and HD (High definition) signals.

Display the selectable settings for the current programme

Check or change the current programme status instantly



- To change

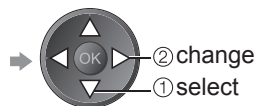

Multi Video (DVB mode)
Allows you to select the image (if available)

Multi Audio (DVB mode)
Allows you to select between alternative language for sound tracks (if available)

Dual Audio (DVB mode)
Allows you to select stereo / monaural (if available)

Sub Channel (DVB mode)
Allows you to select the multifeed programme - sub channel (if available)

Subtitle Language (DVB mode)
Allows you to select the language in which subtitles should appear (if available)

Note

- Also possible to change the settings in Menu list (p. 26 - 31).

Teletext Character Set
Sets the teletext language
➔ Setup Menu (p. 30)

Teletext Language (DVB mode)
Allows you to select between alternative language for teletext (if available)

MPX (Analogue mode)
Selects multiplex sound mode (if available)
➔ Sound Menu (p. 27)

Volume Correction
Adjusts volume of individual channel or input mode

Last view

Switch to previously viewed channel or input mode easily



- Press again to return to the present view.

Note

- Switching channel is not available while Timer Programming or Direct TV Recording is in progress.
- Watching less than 10 sec. is not regarded as the previously viewed channel or input mode.

Off Timer

Turn the TV to Standby mode automatically after a fixed period

Display the menu



Select "Setup"

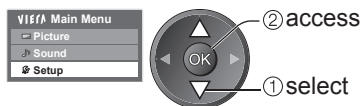

Select "Off Timer" and set the time

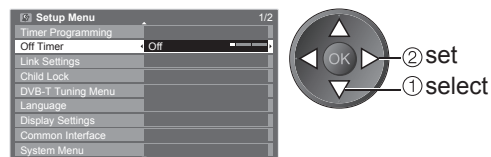

- To cancel ➔ Set to "Off" or turn the TV off.
- To display the remaining time ➔ Information banner (p. 15)

Note

- When the remaining time is within 3 minutes, the remaining time will flash on the screen.

Using TV Guide

TV Guide - Electronic Programme Guide (EPG) provides an on screen listing of the programmes currently broadcast and the forthcoming broadcasts over the next seven days (depending on the broadcasters).

- This function varies depending on the country you select (p. 12).
- The postcode entry or update may be required to use the GUIDE Plus+ system depending on the country you select. → "View advertisement" (p. 19)
- DVB-T and Analogue channels are displayed on the same TV Guide screen. Analogue channels will be listed after DVB-T channels but there will be no programme listings. "D" means DVB-T channel and "A" means Analogue channel.
- When this TV is turned on for the first time, or the TV is switched off for more than a week, it may take some time before the TV Guide is completely shown.



1 Select the mode
→ p. 14

2 View TV Guide

- To change the layout (Landscape / Portrait) view "Landscape" to see many channels view "Portrait" to see one channel at a time

TV Guide time: Example: Wed 28.10.2009 10:46

Current date and time: Wed 28.10.2009

TV Guide date: Wed 28.10.2009

Programme: All Types, All Channels

D 1 BBC ONE	Das Erste	DIY SOS	The Bill	Red Cap
D 7 BBC THREE	Hot Wars		Holiday Program	
D 14 E4	Emmerdal	Coronation Street	The Bill	
D 70 BBC FOUR	10 O'clock News BBC	Pepsi Char.	Good bye	
D 72 BBC 2W	Panorama	Spring watch	Coast	
D 105 BBC1	T'm A Celebrity	Pop Idol	News	
D 719 BBC Radi	Rugby	15 To 1	The Bill	

Advertisement: Channel position and name

Landscape (Displays by channel)

D: DVB-T
A: Analogue

TV Guide time: Example: Wed 28.10.2009 10:46

Current date and time: Wed 28.10.2009

TV Guide date: Wed 28.10.2009

Programme: All Types, All Channels

D 1 BBC ONE	Das Erste
D 7 BBC THREE	DIY SOS
D 14 E4	The Bill
D 70 BBC FOUR	Red Cap
D 72 BBC 2W	Good bye
D 105 BBC1	POP 100
D 719 BBC Radi	Rugby

Portrait (Displays by time)

To return to TV
EXIT

To watch the programme

Select the current programme or channel

Select "View" (DVB mode)

① select

② access

Das Erste 19:30-20:00

View Timer Programming

① select

② watch

• To use Timer Programming → p. 19

To the previous day (DVB mode)
→ red

To the next day (DVB mode)
→ green

Depending on the country you select, you can select the TV Guide type
→ "Default Guide" in "Display Settings" (p. 30)

If you select "Channel List", the channel list will appear when the GUIDE button is pressed.

All DVB-T Channels	Sorting 123...
6: Gaijin News	
7: BBC Radio Wales	
8: BBC Radio Cymru	
1: BBC ONE Wales	
2: BBC THREE	
3: BBC	
4: CBBC Channel	

(Channel list)

① select channel

② watch

To view a channel list of the selected type (DVB mode)
→ yellow

Prog.Type (Type list)

All Types
Movie
News
...

① select type

② view

To view a channel list of the selected category
→ blue

Category (Category list)

All Channels
All DVB-T Channels
All Analogue Channels
Free TV
Pay TV
HDTV
Free Radio
Pay Radio
Favourites1
Favourites2
Favourites3
Favourites4

Only Analogue channels are listed

① select category

② view

• To list favourite channels → p. 35

Other useful functions

View details of the programme (DVB mode)

Select the programme



View details



Details

- Press again to return to TV Guide.

Timer Programming (DVB mode)

Timer Programming is a timer to remind watching or record the programme to the external recorder.

Select the forthcoming programme

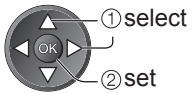

Select the function (Reminder or Ext Rec.)

Function	No.	Channel Name	Date	Start	End
Ext Rec.	1	BBC ONE	Wed 28.10.2009	20:00	20:30
		<TIMER>		(-- min.)	(-- min.)
				(-- min.)	(-- min.)
				(-- min.)	(-- min.)

(Timer Programming screen)

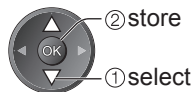

- LED will turn to orange if Timer Programming is set. (Orange LED will flash if Timer Programming is in progress.)

Ext Rec. : to record the programme to the recorder

When the start time comes, the channel will be switched automatically and the video and audio signals will be output. 2 mins. before the starting time, a reminder message appears if you are watching TV.

Reminder : to remind watching the programme

When you are watching TV, a reminder message appears 2 mins. before the start time. Press the OK button to switch to the programmed channel. No signals will be output from any terminals.

To check / change / cancel a Timer Programming event → "Timer Programming" (p. 39)

To return to TV Guide → RETURN

If you select the current programme

A confirmation screen whether you wish to watch or record it will appear.

Select "Timer Programming" and set "Ext Rec." to record from the time you finish the timer programming event setting.

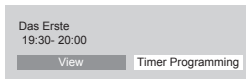

Note

- This function is not available in Analogue mode.
- Timer Programming does not work properly if the TV does not acquire the correct time data from the TV signal.
- No other channel can be selected while Ext Rec. of Timer Programming is in progress.
- When recording programmes, be sure to make the proper settings on the recorder connected to the TV. If a compatible recorder with Q-Link, VIERA Link or similar technologies is connected to the TV (p. 52 and p. 53) and the "Link Settings" (p. 28) are completed, no setting of the recorder is required. Also read the manual of the recorder.

View advertisement

Depending on the country you select, this TV supports the GUIDE Plus+ system in DVB-T or Analogue mode

The postcode entry or update is required. Follow the message's instructions.

- Also possible to setup manually from the Setup Menu
 - "Update" / "Postcode" in "GUIDE Plus+ Settings" (p. 31)
- Enter your postcode when using this function for the first time. If you enter an incorrect postcode for your area, or no postcodes are entered, advertisement may not be displayed correctly.

Display advertisement information

OPTION



- To display the latest advertisement
 - "Update" in "GUIDE Plus+ Settings" (p. 31)

To change advertisements →



To return to TV Guide → OPTION or RETURN

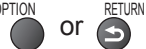

Note

- To update the information continuously, the TV must be left in Standby mode at night.

Viewing Teletext

Teletext services are the text information provided by the broadcasters. The features may vary depending on the broadcasters.



What is FLOF (FASTTEXT) mode?

In FLOF mode, four differently coloured subjects are situated at the bottom of the screen. To access more information about one of these subjects, press the appropriately coloured button. This facility enables fast access to information on the subjects shown.

What is TOP mode? (in case of TOP text broadcasting)

TOP is a particular improvement of the standard teletext service that results in an easier search and effective guide.

- Fast overview of the teletext information available
- Easy to use step-by-step selection of the topical subject
- Page status information at the bottom of the screen

Available page up / down →  
red green

To select among subject blocks → 
blue

To select next subject within the subject block
(After the last subject, it moves to the next subject block.) → 
yellow





What is List mode?

In List mode, four differently coloured page numbers are situated at the bottom of the screen. Each of these numbers can be altered and stored in the TV's memory. ("Store frequently viewed pages", p. 21)

■ To change mode → "Teletext" in the Setup Menu (p. 30)



1 Switch to Teletext
 ● Displays the index page (content varies depending on the broadcasters)

2 Select the page
   0
 or  up down

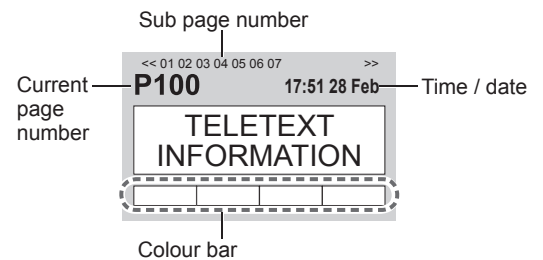

or    
 (Corresponds to the colour bar)

■ To adjust contrast →  (press three times) →

As the blue bar is displayed



■ To return to TV → 

Reveal hidden data

Reveal hidden words e.g. quiz page answers

 →  ● To rehide → 

FULL / TOP / BOTTOM

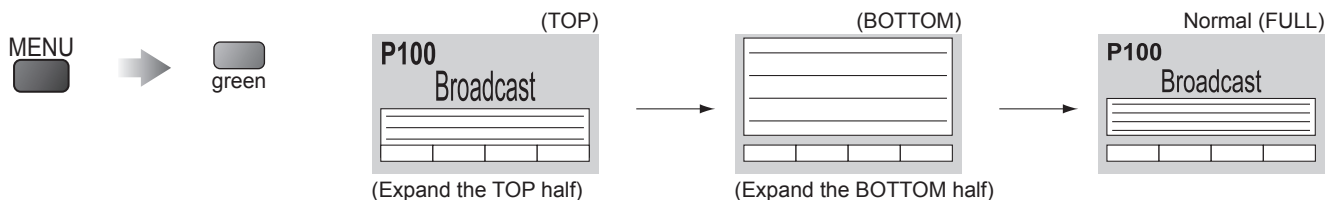

HOLD

Stop automatic updating

(If you wish to hold the current page without updating)

 ● To resume → 

INDEX

Return to the main index page



Call up a favourite page

View a favourite page stored



- Call up the page stored on the blue button (List mode).
- Factory setting is "P103".

View in multi window

Watch TV and Teletext in two windows at once



(press twice)



Select Picture and text On or Off



- Operations can be made only in Teletext screen.

Store frequently viewed pages

Store frequently viewed pages in the colour bar

(List mode only)

As page is displayed



Corresponding coloured button



press and hold

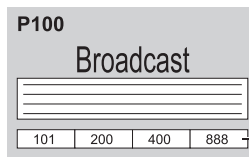

The number changes to white.

■ To change stored pages



Coloured button you want to change

Enter new page number



press and hold

View sub page

View sub page (Only when teletext is more than one page)



<<01 02 03 04 05 — Appears at top of the screen

■ To view specific sub page



Enter the 4-digit number
example: P6

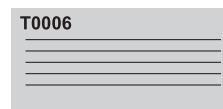

- Sub pages:
The number of sub pages varies depending on the broadcasters (up to 79 pages).
It may take some time for searching, during which time you can watch TV.

Watch TV while waiting for update

View the TV picture while searching for a teletext page

Teletext automatically updates itself when new information becomes available.



Changes to TV screen temporarily

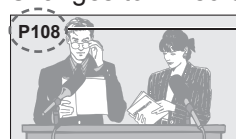

Appears when updating is completed

View the updated page



(You cannot change the channel.)

- The news page provides a function that indicates arrival of latest news ("News Flash").

Watching External inputs

Connect the external equipment (VCRs, DVD equipment, etc.) and you can watch through the input.

● To connect the equipment → p. 10, 11 and p. 58

The Remote Control is capable of operating some functions of selected external equipment.

1 Turn the TV on

- **When connecting with SCART as example 2 or 3** (p. 10 and p. 11)
 - Receives input signals automatically when playback starts
 - Input signals are automatically identified by the SCART (pin 8) terminal.
 - This function is also available for HDMI connections (p. 58).
- **If input mode is not switched automatically**
 - Perform ② and ③
 - Check the setup of the equipment.

2 Display the Input select menu

AV

3 Select the input mode connected to the equipment

Input Selection	
AV1/S	--
AV2	
COMPONENT	
PC	
HDMI1	
HDMI2	
TV	

① select
② watch

- You can also select the input using the AV button on the remote control or the side panel of the TV.
- Press the button repeatedly until the desired input is selected.
- In order to switch between AV1 and AV1S, move the indicator by pressing left and right cursor button.
- You can label or skip each input mode → “Input Labels” (p. 41)
- Skipped inputs will not be displayed when the AV button is pressed.

4 View

Displays the selected mode

AV1

■ **To return to TV**









→ TV

Note

- If the external equipment has an aspect adjustment function, set to “16:9”.
- For details, see the manual of the equipment or ask your local dealer.

Operating the equipment with the TV remote control

The equipment connected to the TV can be directly operated with the below buttons of this TV remote control.

	Standby Set to Standby mode / Turn on
	Play Playback videocassette / DVD
	Stop Stop the operations
	Rewind / Skip / Search VCR: Rewind, view the picture rapidly in reverse DVD: Skip to the previous track or title Press and hold to search backward
	Fast-forward / Skip / Search VCR: Fast-forward, view the picture rapidly forward DVD: Skip to the next track or title Press and hold to search forward
	Pause Pause / Resume DVD: Press and hold to play at slow speed
	Channel Up / Down Select channel
	Record Start recording



■ How to change the code for the type of the equipment

Each type of the Panasonic equipment has its own remote control code.

Please change the code according to the equipment you want to operate.

If you operate the connected equipment in VIERA Link (p. 56), select the code "73".

Press and hold  during the following operations

Enter the appropriate code, see table below  → Press 

Type of the equipment	Code
DVD Recorder, DVD Player	70 (default)
Player theatre, Blu-ray Disc theatre	71
VCR	72
The equipment using in VIERA Link → "VIERA Link Control" (p. 56)	73

Note

- Confirm if the remote control works correctly after changing the code.
- The codes may be reset to default values if batteries are replaced.
- Some operations may not be possible on some equipment models.

How to Use VIERA TOOLS

You can access some special features easily by using the VIERA TOOLS function.



1 Display icons of the feature



2 Select a feature

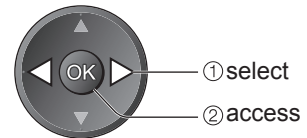

3 Follow the operations of each feature

- VIERA Link Control → “VIERA Link Control” (p. 56)



When two or more compatible equipment are connected, a selection screen will be displayed.
Please select the correct description and access.

- Pause Live TV → “Pause Live TV” (p. 55)



- Photo → “Photo mode” (p. 46)



- Video → “Video mode” (p. 48)



■ To return to TV



Note

- If the selected feature is not available, the demonstration to explain how to use it can be displayed. Press the OK button to view the demonstration after selecting the unavailable feature.

How to Use Menu Functions

Various menus allow you to make settings for the picture, sound, and other functions.



1 Display the menu
 MENU ● Displays the functions that can be set (varies according to the input signal)

2 Select the menu

 (example: Picture Menu)

② access
 ① select

3 Select the item

 (example: Picture Menu)

select

4 Adjust or select

 (example: Picture Menu)

① change
 ② store or access (Required by some functions)

■ To return to TV at any time



■ To return to the previous screen



■ To change menu pages

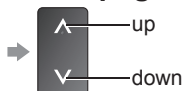

■ Choose from among alternatives

Number and positions of alternatives



Changed

■ Adjust using the slide bar



Moved

■ Go to the next screen



Displays the next screen

■ Enter characters by free input menu

You can enter names or numbers freely for some items.



Set characters one by one

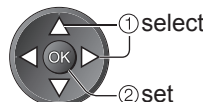

Store



- You can set characters by using numeric buttons.
 ➔ “Characters table for numeric buttons” (p. 62)

■ To reset the settings

- To reset the picture settings only
 ➔ “Reset to Defaults” in the Picture Menu (p. 26)
- To reset the sound settings only
 ➔ “Reset to Defaults” in the Sound Menu (p. 27)
- To reset the picture and sound settings together
 ➔ N (Also volume level and aspect mode are reset)
- To initialise all settings
 ➔ “Shipping Condition” in the Setup Menu (p. 31)

How to Use Menu Functions

■ Menu list

Menu	Item	Adjustments / Configurations (alternatives)
Picture	Viewing Mode	<p>Basic picture mode (Dynamic / Normal / Cinema / True Cinema / Game)</p> <p>In each Viewing Mode and input, Contrast, Brightness, Colour, Sharpness, Tint, Colour Balance, Vivid Colour, Eco Mode, P-NR and 3D-COMB can be adjusted and stored to suit your particular viewing requirement.</p> <ul style="list-style-type: none"> ● Set for each input signal. <p>Dynamic : Provides enhanced picture contrast and sharpness when viewing in a bright room.</p> <p>Normal : Recommended for viewing under normal ambient room lighting conditions.</p> <p>Cinema : For watching movies in a darkened room with the improved performance of contrast, black and colour reproduction</p> <p>True Cinema : Precisely reproduces the original quality of the image without any revision.</p> <p>Game : Fast response signal specifically to provide suitable images for playing games</p> <ul style="list-style-type: none"> ● Not valid on TV mode ● A continuous record of time spent using Game mode can be displayed in the top right of the screen. <ul style="list-style-type: none"> ➔ "Playing Time Display" (p. 30)
	Contrast, Brightness, Colour, Sharpness	Increases or decreases the levels of these options according to your personal preference
	Tint	<p>With an NTSC signal source connected to the TV, the picture hue can be adjusted to suit your taste</p> <ul style="list-style-type: none"> ● For NTSC signal reception only
	Colour Balance	Allows you to set the overall colour tone of the picture (Cool / Normal / Warm)
	Vivid Colour	<p>Automatically adjusts colours to vivid ones (Off / On)</p> <ul style="list-style-type: none"> ● Not valid on PC signal
	Eco Mode	<p>Automatic Brightness Control function</p> <p>Adjusts picture settings automatically dependent on ambient lighting conditions (Off / On)</p>
	P-NR	<p>Picture Noise Reduction</p> <p>Automatically reduces unwanted picture noise and flicker noise in the contoured parts of a picture (Off / Min / Mid / Max)</p> <ul style="list-style-type: none"> ● Not valid on PC signal
	3D-COMB	<p>Makes still or slow moving pictures look more vivid (Off / On)</p> <ul style="list-style-type: none"> ● Occasionally, whilst viewing still or slow moving pictures, colour patterning may be seen. Set to "On" to display sharper and more accurate colours. ● For PAL or NTSC signal reception only ● Not valid on RGB, S-Video, Component, PC, HDMI and SD Card
	Panel	<p>Turns the screen off when you select "Off" (Off / On)</p> <ul style="list-style-type: none"> ● The sound is active even if the screen turns off. ● Press any buttons to turn the screen on. ● This function is effective in reducing power consumption when listening to a sound without watching the TV screen.
	Reset to Defaults	Press the OK button to reset the present Picture Viewing Mode to the default settings

Menu	Item	Adjustments / Configurations (alternatives)
Sound	Mode	Selects the basic sound mode (Music / Speech / User) <ul style="list-style-type: none"> ● The selected mode affects all input signals. Music: Improves sound quality for watching music video, etc. Speech: Improves sound quality for watching news, drama, etc. ● In Music and Speech mode, you can adjust “Bass” and “Treble” settings, and those settings will be stored for each mode. User: Adjusts the sounds manually by using the equalizer to suit your favourite sound quality. ● For the User mode, “Equalizer” will appear on the Sound Menu instead of “Bass” and “Treble”. Select the “Equalizer” and adjust the frequency. ➔ “Equalizer” (below)
	Bass	Increases or decreases level to enhance or minimise lower, deeper sound output
	Treble	Increases or decreases level to enhance or minimise sharper, higher sound output
	Equalizer	Adjusts the frequency level to suit your favourite sound quality <ul style="list-style-type: none"> ● This function is available when “Mode” is set to “User”. ● Select the frequency and change the frequency level by using the cursor button. ● If you want to enhance the bass sound, raise the level of the lower frequency. If you want to enhance the treble sound, raise the level of the higher frequency. ● To reset the levels of each frequency to the default settings, select the “Reset to Defaults” by using cursor button, and then press the OK button.
	Balance	Adjusts volume level of right and left speakers
	Headphone Volume	Adjusts the volume of the headphones
	Surround	Surround sound settings (Off / V-Audio) V-Audio: Provides a dynamic enhancer of width to simulate improved spatial effects
	Volume Correction	Adjusts the volume of individual channel or input mode
	Speaker Distance to Wall	Adjusts the low frequency sound (Over 30cm / Up to 30cm) <ul style="list-style-type: none"> ● If the back space between the TV and wall is over 30 cm, “Over 30cm” is recommended. ● If the back space between the TV and wall is within 30 cm, “Up to 30cm” is recommended.
	MPX	Selects multiplex sound mode (if available) <ul style="list-style-type: none"> ● Normally: Stereo ● Stereo signal cannot be received: Mono ● M1 / M2: Available while mono signal is transmitted ● Analogue mode only
	Audio Preference	Selects the initial setting for audio tracks (Auto / MPEG) Auto : Automatically selects the audio tracks if programme has more than two tracks. The priority is given in the following order - Dolby Digital Plus, HE-AAC, Dolby Digital, MPEG. MPEG : The priority is given to MPEG as long as the programme contains MPEG audio. <ul style="list-style-type: none"> ● Dolby Digital Plus and Dolby Digital are the methods of coding digital signals developed by Dolby Laboratories. Apart from stereo (2ch) audio, these signals can be multi-channel audio. ● HE-AAC is a perceptual coding method used to compress digital audio for efficient storage and transmission. ● MPEG is an audio compression method that compresses audio to the smaller size without any considerable loss of audio quality. ● Dolby Digital Plus and HE-AAC are the technologies for HD (High definition) programmes. ● DVB mode only
	SPDIF Selection	SPDIF : A standard audio transfer file format Selects the initial setting for digital audio output signal from DIGITAL AUDIO OUT terminal (Auto / PCM) Auto : Dolby Digital Plus and Dolby Digital are output as Dolby Digital Bitstream. HE-AAC (48 kHz) is output as DTS. MPEG is output as PCM. PCM : Digital output signal is fixed to PCM. <ul style="list-style-type: none"> ● For DVB mode or Video mode (p. 48)
	MPEG Optical Level	Adjusts the audio level of MPEG output from DIGITAL AUDIO OUT terminal as the initial setting (0 / -2 / -4 / -6 / -8 / -10 / -12dB) <ul style="list-style-type: none"> ● Normally, MPEG sound is larger comparing with the other types of audio track. ● DVB mode only
	HDMI1 / 2 Input	Select to fit the input signal (Digital / Analogue) (p. 63) Digital : HDMI cable connection Analogue : HDMI-DVI adapter cable connection <ul style="list-style-type: none"> ● HDMI input mode only
SPDIF Delay	Adjusts the delay time of the sound output from DIGITAL AUDIO OUT terminal if the sound does not synchronize the image <ul style="list-style-type: none"> ● DVB mode only 	
Reset to Defaults	Press the OK button to reset the present Sound Mode, Balance, Headphone Volume and Surround to the default settings	

- A different menu will be displayed while PC or SD Card is used. (p. 45, 47 and p. 49)
- Only available items can be selected.

Menu	Item	Adjustments / Configurations (alternatives)	
Setup	DVB-C Tuning Menu	Favourites Edit	Creates list of favourite DVB-C channels (p. 35)
		Channel List	Skips the unwanted DVB-C channels or edits DVB-C channels (p. 35)
		Auto Setup	Automatically sets the DVB-C channels supplied (p. 32)
		Manual Tuning	Sets the DVB-C channels manually (p. 35)
		Update Channel List	Updates DVB-C Channel List with keeping your settings (p. 34)
		New Channel Message	Selects whether to give a notification message when a new DVB-C channel is found (Off / On) (p. 34)
		Signal Condition	Checks the DVB-C signal condition (p. 34)
		Attenuator	Automatically reduces the DVB-C signal to avoid the interference (Off / On) (p. 34)
		Add TV Signal	Adds the TV mode <ul style="list-style-type: none"> ● This function is available if you skip any modes to tune in “Auto Setup” for first using the TV. ● To operate, refer to the “Auto Setup” operations for first using the TV (p. 12 and p. 13).
	DVB-T Tuning Menu	Favourites Edit	Creates list of favourite DVB-T channels (p. 35)
		Channel List	Skips the unwanted DVB-T channels or edits DVB-T channels (p. 35)
		Auto Setup	Automatically sets the DVB-T channels received in the area (p. 33)
Manual Tuning		Sets the DVB-T channels manually (p. 35)	
Update Channel List		Updates DVB-T Channel List with keeping your settings (p. 34)	
Favourite Network		Selects your favourite network for each broadcasters (only available in some countries)	
New Channel Message		Selects whether to give a notification message when a new DVB-T channel is found (Off / On) (p. 34)	
Signal Condition		Checks the DVB-T signal condition (p. 34)	
Add TV Signal		Adds the TV mode <ul style="list-style-type: none"> ● This function is available if you skip any modes to tune in “Auto Setup” for first using the TV. ● To operate, refer to the “Auto Setup” operations for first using the TV (p. 12 and p. 13). 	
Analogue Tuning Menu	Channel List	Skips the unwanted Analogue channels or edits Analogue channels (p. 37)	
	Auto Setup	Automatically sets the Analogue channels received in the area (p. 33)	
	Manual Tuning	Sets the Analogue channels manually (p. 37)	
	Add TV Signal	Adds the TV mode <ul style="list-style-type: none"> ● This function is available if you skip any modes to tune in “Auto Setup” for first using the TV. ● To operate, refer to the “Auto Setup” operations for first using the TV (p. 12 and p. 13). 	

- A different menu will be displayed while PC or SD Card is used. (p. 45, 47 and p. 49)
- Only available items can be selected.

How to Use Menu Functions

Menu	Item	Adjustments / Configurations (alternatives)	
Setup	Language	OSD Language	Changes language for on screen displays
		Preferred Audio 1 / 2	Selects the first and second preferred language for DVB multi audio (depending on the broadcaster)
		Preferred Subtitles 1 / 2	Selects the first and second preferred language for DVB subtitles (depending on the broadcaster) ● To display subtitles ➔ p. 16
		Preferred Teletext	Selects the preferred language for DVB teletext service (depending on the broadcaster)
	Display Settings	Preferred Subtitle Type	Selects the preferred subtitle type (Standard / Hard of Hearing) ● “Hard of Hearing” provides aids in understanding and enjoyment with DVB subtitles (depending on the broadcaster). ● “Preferred Subtitles 1 / 2” in “Language” are given priority.
		Teletext	Teletext display mode (TOP (FLOF) / List) (p. 20)
		Teletext Character Set	Selects teletext language (West / East1 / East2) ● West: English, French, German, Greek, Italian, Spanish, Swedish, Turkish, etc. ● East1: Czech, English, Estonian, Lettish, Rumanian, Russian, Ukrainian, etc. ● East2: Czech, Hungarian, Lettish, Polish, Rumanian, etc.
		Default Guide	Selects the default TV Guide type when the GUIDE button is pressed (TV Guide / Channel List) TV Guide : Electronic Programme Guide (EPG) is available. ● To use EPG ➔ p. 18 Channel List: EPG is not available and the channel list will appear instead of it.
		Input Labels	Labels or skips each input terminal (p. 41)
		Banner Display Timeout	Sets how long the Information banner (p. 15) stays on screen (0 (No display) / 1 / 2 / 3 / 4 / 5 / 6 / 7 / 8 / 9 / 10 seconds)
		Playing Time Display	Set to “On” to display a continuous record of time spent using Game mode every 30 mins (Off / On) ● This function is available when “Game” is selected in “Viewing Mode” (p. 26).
		Radio Mode	Sets the timer for turning off the screen automatically when a radio channel is selected (Off / 5 / 10 / 15 / 20 seconds) ● The sound is active even if the screen turns off. ● Press any buttons to turn the screen on. ● This function is effective in reducing power consumption when listening to a radio channel.
		Common Interface	Uses include to watch pay-TV (p. 42)

Menu	Item	Adjustments / Configurations (alternatives)		
Setup	System Menu	Shipping Condition	Resets all settings, for example, when moving house (p. 43)	
		System Update	Downloads new software to TV (p. 44) ● This function does not work on TH-32LRG20E.	
		Software Licence	Displays the software licence information	
		System Information	Displays the system information of this TV	
	Other Settings	AV Colour System		Selects optional colour system based on video signals in AV mode (Auto / PAL / SECAM / M.NTSC / NTSC)
		GUIDE Plus+ Settings	Update	Performs the update of the GUIDE Plus+ schedule and advertising informations for the GUIDE Plus+ system (p. 19)
			Postcode	Sets your postcode to display advertisements in the GUIDE Plus+ system (p. 19)
			System Information	Displays the system information of the GUIDE Plus+ system
		Auto Standby		Sets the time the TV automatically goes to Standby mode when no operation is performed for the selected times (Off / 2 / 4 hours) ● Starting Timer Programming automatically does not affect this function. ● Automatic input switching with the connected equipment affects this function and time-count will be reset. ● The notification message will appear 3 minutes before going to Standby mode.
		Power Save		Reduces brightness of picture to economise on power consumption (Off / On)
		16:9 Overscan		Selects the screen area displaying the image (Off / On) On : Enlarged the image to hide the edge of the image. Off : Displayed the image in the original size. ● Set to "On" if noise is generated on the edge of the screen. ● This function is available when aspect is set to Auto (16:9 signal only) or 16:9. ● This function can be memorized separately for SD (Standard definition) and HD (High definition) signals.
		Time Zone		Adjusts the time data ● The time data will be corrected based on GMT. ● Set to "Auto" to adjust the time automatically according to your area.
	DVI Input Setting		Changes the black level in the image for HDMI input mode with DVI input signal manually (Normal / Full) ● When the DVI input signal from the external equipment, especially from PC, is displayed, the black level may not be suitable. In this case, select "Full". ● The black level for HDMI input signal will be adjusted automatically.	

- A different menu will be displayed while PC or SD Card is used. (p. 45, 47 and p. 49)
- Only available items can be selected.

Retuning from Setup Menu

DVB-C channels

Automatically retune all the DVB-C channels supplied.

- This function is available if DVB-C channel tuning is already performed.
- Only DVB-C channels are retuned.
- All the previous tuning settings are erased.
- If a Child Lock PIN number (p. 40) has been set, it must be entered.



1

Select DVB-C

→ p. 14



2

Display the menu



3

Select "Setup"

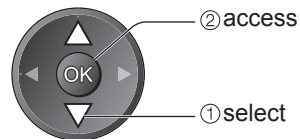
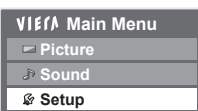

4

Select "DVB-C Tuning Menu"

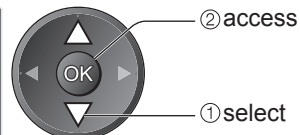
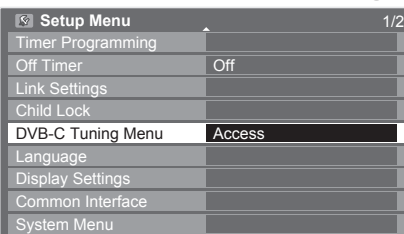

5

Select "Auto Setup"

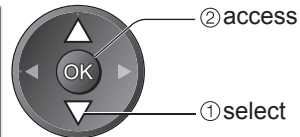
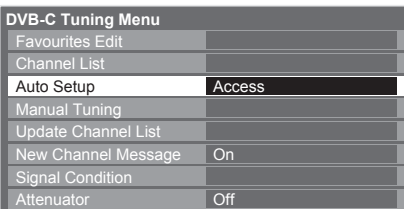

6

Set the Auto Setup settings

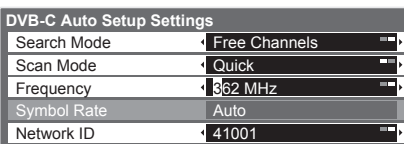

● Normally set Symbol Rate "Auto".

● Search mode, Scan mode

● Frequency, Network ID

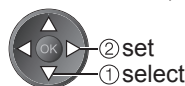

Store



Full: scans the whole frequency range
Quick: scans the suitable frequency in your country

Enter the Home Frequency and Network ID specified by your cable provider. Depending on the country you select, "Auto" is displayed and you do not have to enter them.

7

Start Auto Setup

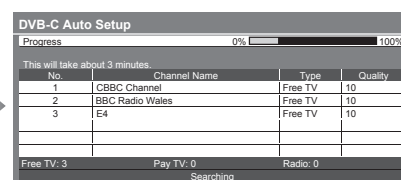
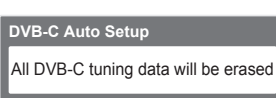

Settings are made automatically

■ To return to TV



■ For Auto Setup, using the buttons on the side panel of the TV (p. 9)

① Press repeatedly until "Auto Setup" appears



② Access "Auto Setup"



③ Set the search mode and scan mode

+/- (select the item)



④ Start "Auto Setup"

AV (confirm)

TV (start)

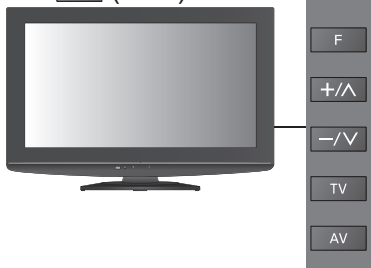

● To return to TV → F

Note

- If tuning has not been done completely → "Manual Tuning" (p. 35)

When the operation is completed, the channel at the lowest position will be displayed.

DVB-T or Analogue channels

Automatically retune all DVB-T or Analogue channels received in the area.

- DVB-T Auto Setup is available if DVB-T channel tuning is already performed.
- Only DVB-T channels are retuned in DVB-T mode.
- Only Analogue channels are retuned in Analogue mode.
- All the previous tuning settings are erased.
- If a Child Lock PIN number (p. 40) has been set, it must be entered.



1 Select DVB-T or Analogue

→ p. 14



2 Display the menu



3 Select "Setup"

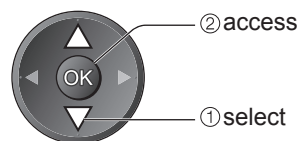
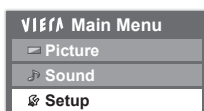

4 Select "DVB-T Tuning Menu" or "Analogue Tuning Menu"

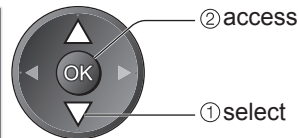
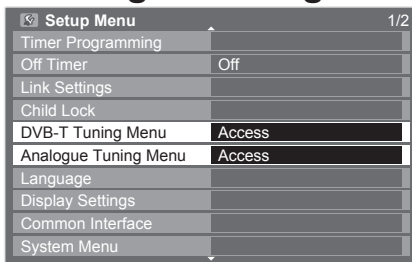

- "DVB-T Tuning Menu" is available in DVB-T mode only.
- "Analogue Tuning Menu" is available in Analogue mode only.

To return to TV



5 Select "Auto Setup"

DVB-T:

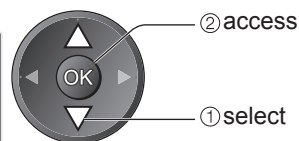
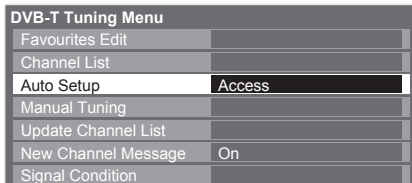

Analogue:

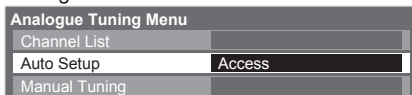

For Auto Setup, using the buttons on the side panel of the TV (p. 9)

- 1 Press repeatedly until "Auto Setup" appears



- 2 Access "Auto Setup"



- 3 Start "Auto Setup"

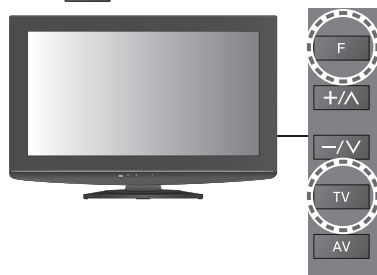

- To return to TV → F

6 Start Auto Setup

DVB-T:

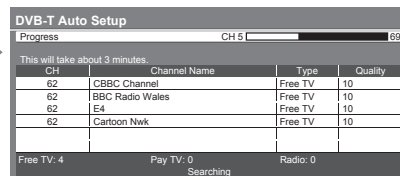
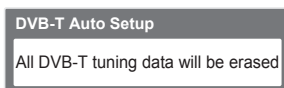

Analogue:

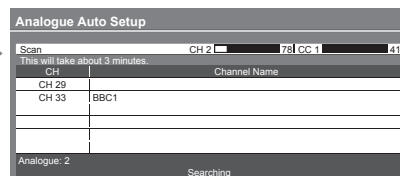
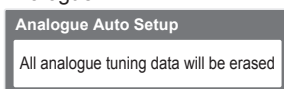

Settings are made automatically

- The channel, language, country / region settings are downloaded to a Q-Link or VIERA Link compatible equipment connected to the TV.

When the operation is completed, the channel at channel position "1" will be displayed.

Note

- If tuning has not been done completely
→ "Manual Tuning" (p. 35 and p. 37)

Tuning and Editing Channels

(DVB)

You can retune channels or make your favourite channel lists, skip unwanted channels, etc.



- 1 Select DVB-C or DVB-T** TV
→ p. 14
- 2 Display the menu** MENU
- 3 Select "Setup"**

VIEWA Main Menu	
Picture	
Sound	
Setup	

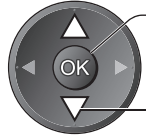

- 4 Select "DVB-C Tuning Menu" or "DVB-T Tuning Menu"**

Setup Menu		1/2
Timer Programming		
Off Timer	Off	
Link Settings		
Child Lock		
DVB-C Tuning Menu	Access	
DVB-T Tuning Menu	Access	
Language		
Display Settings		
Common Interface		
System Menu		

 - "DVB-C Tuning Menu" is available in DVB-C mode only.
 - "DVB-T Tuning Menu" is available in DVB-T mode only.
- 5 Select one of the following functions and set**

DVB-C Tuning Menu	
Favourites Edit	Access
Channel List	Access
Auto Setup	Access
Manual Tuning	Access
Update Channel List	Access
New Channel Message	On
Signal Condition	Access
Attenuator	Off

 - The function items vary depending on the country you select (p. 12).
 - Auto Setup → "Retuning from Setup Menu" (p. 32 and p. 33)

■ To return to TV
EXIT

Update DVB channel automatically Update Channel List

You can add new channels, delete removed channels, update channel name and position automatically to Channel List.

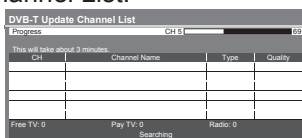

- Channel List is updated with keeping your settings in Favourites Edit, Channel List, Child Lock, etc.

Display a notification message New Channel Message

Selects whether to give a notification message when a new DVB channel is found. (Off / On)



- Selecting OK will perform "Update Channel List".

Check DVB signal Signal Condition

Selects a channel and checks the DVB signal condition.

- To change the channel → 

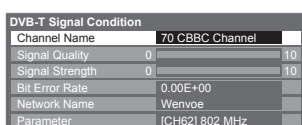

A good Signal Strength is not an indication of suitable signal for DVB reception. Please use the Signal Quality indicator as follows:

Signal Quality:

- Green bar → Good
- Yellow bar → Poor
- Red bar → Bad (Check the Terrestrial aerial or cable)

Reduce the DVB-C signal Attenuator

If the DVB-C signal is too strong, the interference may occur. In this case set to "On" to reduce the signal automatically.

- This function is available only for DVB-C signal.

List favourite DVB channels **Favourites Edit**

Create your favourite channel lists from various broadcasters (up to 4: Favourites1 to 4). The DVB Favourites lists are available from "Category" in the Information banner (p. 15) and the TV Guide (p. 18).

① Select a channel to list

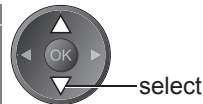
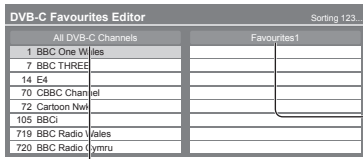

- To sort channel names in alphabetical order → blue
- To display other Favourites → green
- To change the category → red

② Add it to the Favourites list

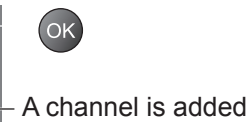
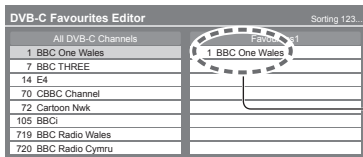

- To add continuous block of channels to the list at once → yellow → Make the block → OK → OK

■ To edit Favourites list



Select the field of Favourites to edit and:

- To name the Favourites → red

Set characters one by one



(maximum: ten characters)

You can set characters by using numeric buttons.

→ "Characters table for numeric buttons" (p. 62)

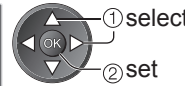

- To delete the channel → OK
- To delete all channels → yellow

- To move the channel → green

Select the new position → OK or numeric keypad → Confirm → green

③ Store → OK

Skip unwanted DVB channels, Edit DVB Channels **Channel List**

You can hide unwanted DVB channels. The hidden channels cannot be displayed except in this function. Use this function to skip unwanted channels.

Select a channel and reveal / hide

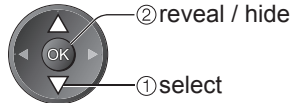
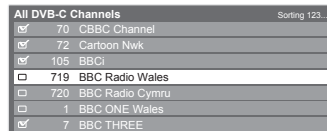

- : reveal
- : hide (skip)

- To reveal all channels → yellow

■ To edit channels

You can also edit each channel in Channel List.

- To change the category → red
- To swap the channel position (if available) → green → Enter the new position number → Store → green
- To move the channel position (if available) → green → Select the new position → OK → Store → green
- To sort channel names in alphabetical order → blue

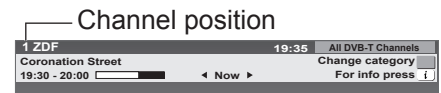

Set DVB channel manually **Manual Tuning**

Normally use "Auto Setup" or "Update Channel List" to retune DVB channels. If tuning has not been done completely or for adjusting the direction of the aerial, use this function.

- All channels found will be added to the Channel List.

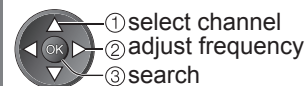
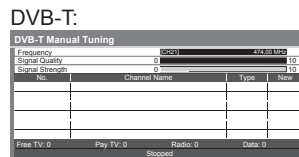
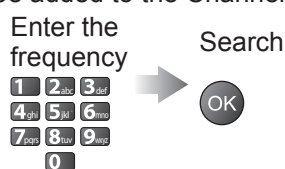
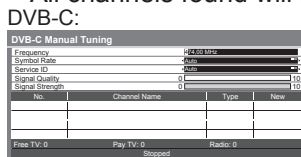



- Normally set Symbol Rate and Service ID to "Auto".
- Set where the level of "Signal Quality" becomes the maximum.

Tuning and Editing Channels

(Analogue)

You can retune channels or skip unwanted channels, edit channels etc.



- 1 Select Analogue**
 → p. 14

- 2 Display the menu**

- 3 Select "Setup"**

Main Menu	
Picture	
Sound	
Setup	



② access
① select
- 4 Select "Analogue Tuning Menu"**

Setup Menu		1/2
Timer Programming		
Off Timer	Off	
Link Settings		
Child Lock		
Analogue Tuning Menu	Access	
Language		
Display Settings		
Common Interface		
System Menu		



② access
① select
- 5 Select one of the following functions**

Analogue Tuning Menu	
Channel List	Access
Auto Setup	Access
Manual Tuning	Access



② access
① select

 - The function items vary depending on the country you select (p. 12).
 - Auto Setup → "Retuning from Setup Menu" (p. 33)
- 6 Set**

■ To return to TV
 EXIT

Skip unwanted Analogue channels, Edit Analogue channels Channel List

You can hide unwanted Analogue channels. The hidden channels cannot be displayed except in this function. Use this function to skip unwanted channels.

Select a channel and reveal / hide

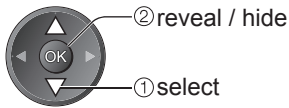
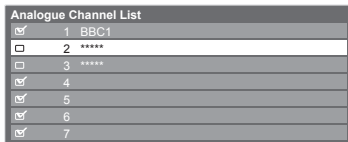

: reveal
 : hide (skip)

To reveal all channels
 → yellow

To edit channels

You can also edit each channel in Channel List.



Select a channel to edit and:

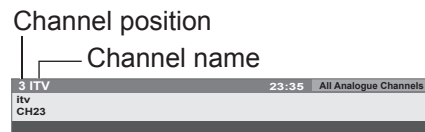

To retune each channel (Manual Tuning) → red (see below)

To move the channel position → green → Select the new position → Store green

To rename the channel name → blue → Set characters one by one → Store RETURN



(maximum: five characters)

- You can set characters by using numeric buttons.
- "Characters table for numeric buttons" (p. 62)

Note

- If a VCR is connected only with the RF cable, edit "VCR".

Set Analogue channel manually Manual Tuning

Fine Tuning

Use to make small adjustments to the tuning of an individual programme (affected by weather conditions, etc.)

Manual Tuning

Set Analogue channel manually after Auto Setup.

- Set Sound System and Colour System, and then perform this function. Normally set Colour System "Auto".
- If a VCR is connected only with the RF cable, select channel position "0".

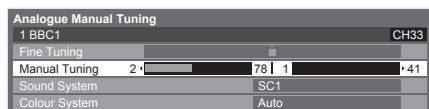

SC1: PAL B, G, H / SECAM B, G
 SC2: PAL I
 SC3: PAL D, K / SECAM D, K
 F: SECAM L, L'

Select the channel position



Select the channel



Search and store

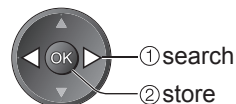



Timer Programming

Timer Programming from Menu



The Timer Programming menu allows you to choose programmes that you wish to record or remind watching. At the correct time, the TV will switch on and tune to the correct channel even if the TV is in Standby mode.

TV Guide may also be used to set timer programming (p. 19).

- This function is not available in Analogue mode.
- Timer Programming does not work properly if the TV does not acquire the correct time data from the TV signal.
- The TV must be either On or in standby for Ext Rec. of Timer Programming.
- No other channel can be selected while Ext Rec. of Timer Programming is in progress.
- It may not be possible to record an encrypted programme (which is copy-protected).
- When recording programmes, be sure to make the proper settings on the recorder connected to the TV.
If a compatible recorder with Q-Link, VIERA Link or similar technologies is connected to the TV (p. 52 and p. 53) and the "Link Settings" (p. 28) are completed, no setting of the recorder is required. Also read the manual of the recorder.
- If the recorder is not compatible with Q-Link, VIERA Link or similar technologies make timer programming of the recorder. For preparations of a recorder, read the manual of the recorder.
- Recording is possible in composite video via SCART only, including HD content.
- 2 mins. before the starting time, a reminder message appears if you are watching TV.

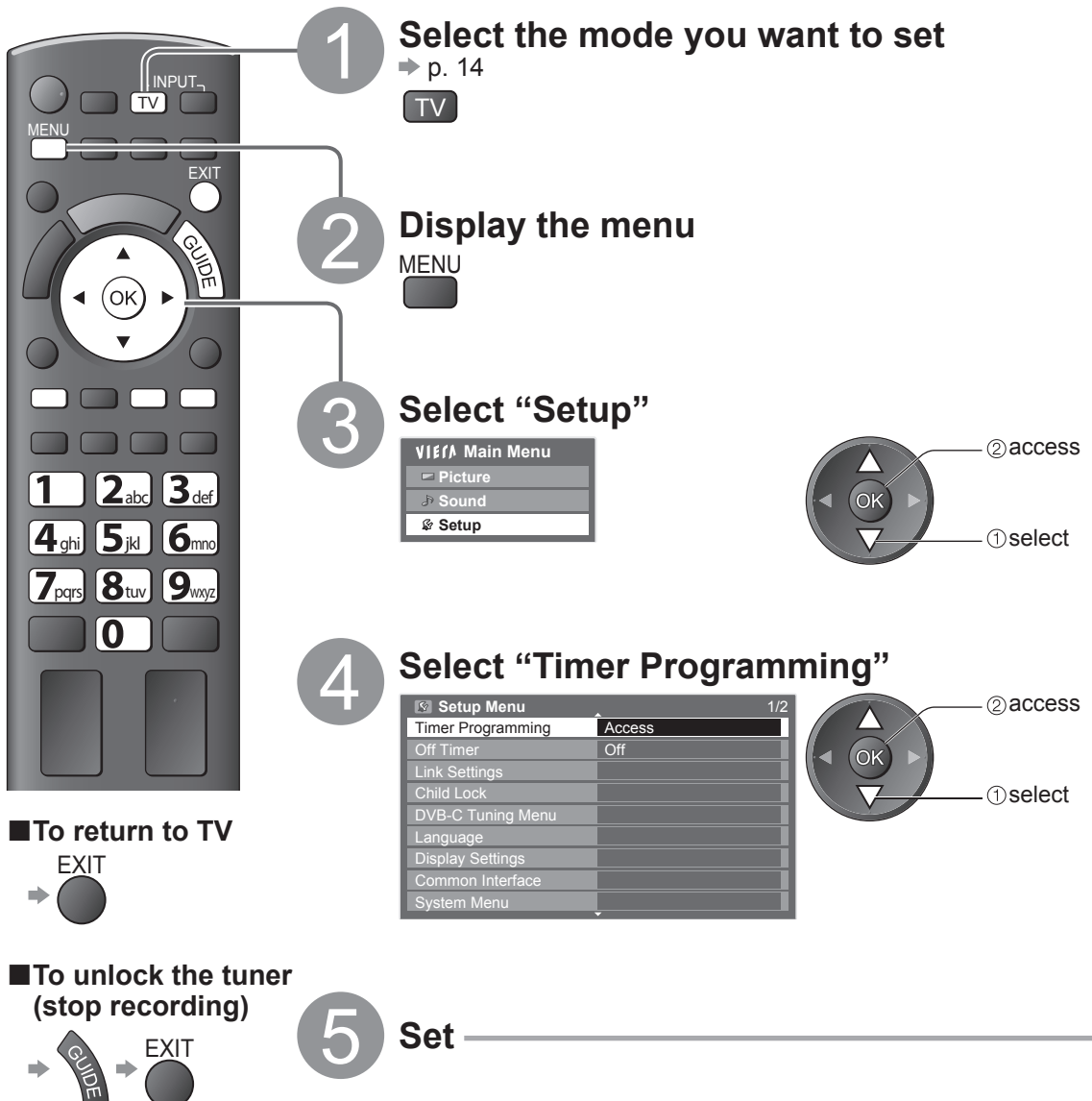
- To remove the message and start the programming → 
- To cancel the programming → 





- Select the mode you want to set**
→ p. 14

- Display the menu**

- Select "Setup"**



Main Menu	
Picture	
Sound	
Setup	

- Select "Timer Programming"**

Setup Menu		1/2
Timer Programming	Access	
Off Timer	Off	
Link Settings		
Child Lock		
DVB-C Tuning Menu		
Language		
Display Settings		
Common Interface		
System Menu		

- Set**

■ To return to TV
→ 

■ To unlock the tuner (stop recording)
→  → 

Set timer programming details Timer Programming

① Start making the settings

OK

② Select the function (Reminder or Ext Rec.)



Ext Rec. : to record the programme to the recorder
When the start time comes, the channel will be switched automatically and the video and audio signals will be output. 2 mins. before the starting time, a reminder message appears if you are watching TV.

Reminder : to remind watching the programme
When you are watching TV, a reminder message appears 2 mins. before the start time. Press the OK button to switch to the programmed channel. No signals will be output from any terminals.

③ Set the channel, date and time (repeat the operations as below)

Set items in the order of ① to ④.



● ①, ③ and ④ can also be entered with numeric buttons.



Displayed if the timer programming events are overlapped

Timer Programming			Wed 28.10.2009 10:46	
Function	No.	Channel Name	Date	Start End
Reminder	D 7	BBC7 <TIMER>	Wed 28.10.2009	17:00 18:30 (90 min.)
Ext Rec.	D 1	BBC1 <TIMER>	STTL Wed 28.10.2009	18:00 20:00 (120 min.)
Ext Rec.	C 3	ITV1 <TIMER>	Thu 29.10.2009	21:30 22:30 (60 min.)

Records with subtitles (if available)

● To indicate this → yellow (press again to remove subtitles)

Duration (automatic display)

④ Ending time

③ Starting time

① Channel number

② Date

C: DVB-C
D: DVB-T
(you cannot change TV mode within the menu)

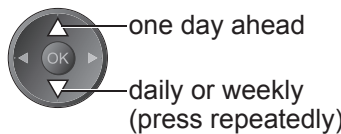

- Daily Sun-Sat: Sunday to Saturday
- Daily Mon-Sat: Monday to Saturday
- Daily Mon-Fri: Monday to Friday
- Weekly Sat/Fri/Thu/Wed/Tue/Mon/Sun: Same time on the same day every week

④ Store

OK

■ To change a timer programming event

→ Select the programme to be changed ② access → Correct as necessary (as above)
① select

■ To cancel a timer programming event

→ Select the programme to be deleted → red → OK

■ To record with subtitles (if available)

→ Select the programme to record with subtitles → yellow ● Each time pressed: auto ←→ off

■ To cancel a timer programming event temporarily

→ Select the programme to be cancelled → blue ● Each time pressed: cancel ←→ stop cancelling

Note

- Check that the LED is lit (orange). If not, timer programmes are not active or not stored.
- “!” identifies that any timer programming events have overlapped. “Ext Rec.” is given priority over “Reminder”. As for the overlapped two or more “Ext Rec.”, the first timer programming event starts and finishes as programmed. The next timer programming event can then start.
- Ext Rec. of Timer Programming will automatically change to the programmed channel 10 seconds before the start time.
- To stop recording the timer programming event directly prior to the start time, it is necessary to stop the recorder manually.
- Ext Rec. of Timer Programming will be performed even if the TV is in Pause Live TV recording (p. 55). In this case, Pause Live TV recording will be cancelled.

Child Lock

You can lock specific channels / AV input terminals and control who watches them. When the locked channel / input is selected, a message appears; by entering the PIN number, you can watch it.



1 Display the menu



2 Select "Setup"

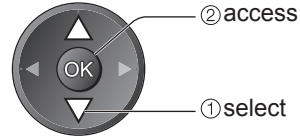
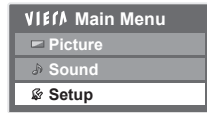

3 Select "Child Lock"

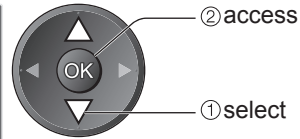
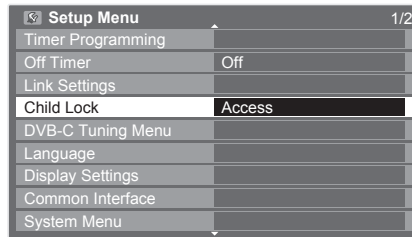

4 To return to TV



4 Set

Control channel audience **Child Lock**

1 Enter the PIN number (4 digits)



- Enter the PIN number twice at first setting.
- Make a note of the PIN number in case you forget it.
- "0000" may be stored as the default PIN number which depends on the country you select (p. 12).

2 Select "Child Lock List"

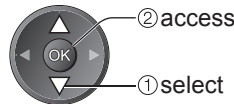
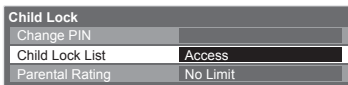

3 Select the channel / input to be locked

Name	Input	Type	Lock
101 BBC 1 Wales	DVB-C	FreeTV	Lock
7 BBC THREE	DVB-T	FreeTV	Lock
14 E4	DVB-T	FreeTV	Lock
VCR	Analogue	Analogue	Lock
1 BBC1	Analogue	Analogue	Lock
2 ****	Analogue	Analogue	Lock
AV1/S	External	AV	Lock
AV2	External	AV	Lock

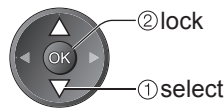

- To cancel → Select the locked channel / input → OK
- To jump to the top of the next input → red
- To lock all → green
- To cancel all locks → yellow
- To sort channel names in alphabetical order → blue

Appears when the channel / input is locked

To change the PIN number

Select "Change PIN"

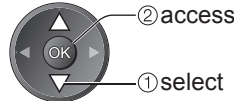
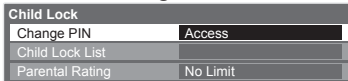

Enter a new PIN number twice



To set Parental Rating

- The availability of this function depends on the country you select (p. 12).

If the DVB programme has the rated information for over the selected age, you have to enter the PIN number to watch (depending on the broadcaster).

Select "Parental Rating" and set an age for the restriction of programmes.

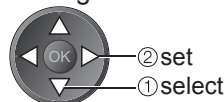

Note

- Setting "Shipping Condition" (p. 43) erases the PIN number and all settings.

Input Labels

For easier identification and selection of the input mode, you can label each input mode or skip terminal that is not connected to any equipment.

- To select the input mode → p. 22



- 1 Display the menu**
 MENU
- 2 Select "Setup"**
- 3 Select "Display Settings"**
- 4 Select "Input Labels"**
- 5 Select a input terminal and set**

■ To return to TV
 EXIT

The labels you set will be displayed in "Input Selection" menu (p. 22), "TV Selection" menu (p. 14) or banner.

- If "Skip" is selected, you cannot select the mode.

■ User input

You can name each input mode freely.

Select "User input"

Set characters one by one

Store

(maximum: ten characters)

- You can set characters by using numeric buttons.
 → "Characters table for numeric buttons" (p. 62)

Using Common Interface

The Common Interface Module menu provides access to software contained on Common Interface (CI) Modules.

● This function may not be available in some countries or regions.

Although CI module may enable you to view some services, this TV does not guarantee all services (e.g. pay-TV).

Please use only the approved CI module by the broadcaster.

Consult your local Panasonic dealer or broadcasters for more information and conditions of the services.

Caution

- Turn Off Mains power On / Off switch whenever inserting or removing the CI module.
- If a view card and a card reader come as a set, first insert the card reader, then insert the view card into the card reader.
- Insert the module in the correct direction.

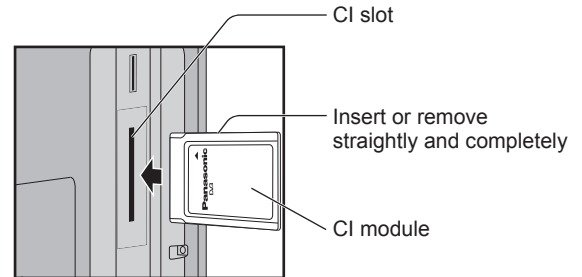

Side of the TV

Insert the CI module (optional)

- The features that appear on screen are dependent on the contents of the selected CI module.
- Normally pay-TV channels will appear. Follow the on screen operation guide. If pay-TV channel does not appear, perform below.
- For more details, see the manual of the CI module, or check with the broadcaster.

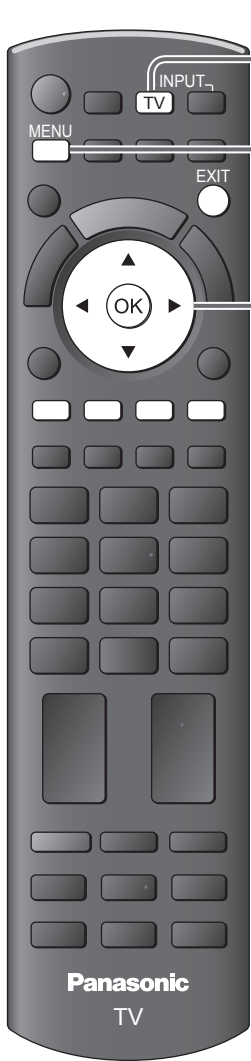

1 Select DVB-C or DVB-T

→ p. 14



2 Display the menu

MENU



3 Select "Setup"

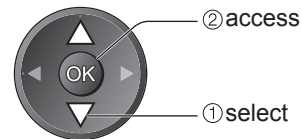
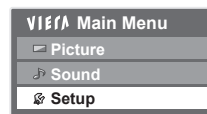

4 Select "Common Interface"

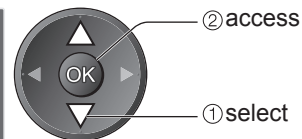
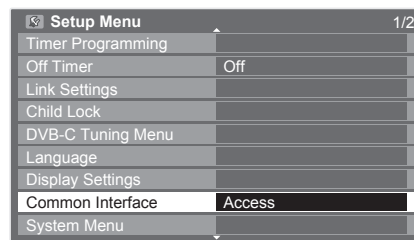

5 Access Common Interface



6 Follow the on screen operation guide

For example: select, go → OK



Coloured characters → red green yellow blue

■ To return to TV



- On screen operation guide may not correspond to the remote control buttons.

Shipping Condition

Resets the TV to its original condition, i.e. no channels tuned in. All settings are reset (channels, picture, sound settings, etc.).



1 Display the menu
MENU

2 Select "Setup"

VIEW Main Menu
Picture
Sound
Setup

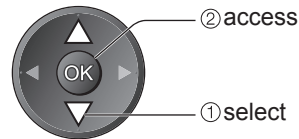

3 Select "System Menu"

Setup Menu	1/2
Timer Programming	
Off Timer	Off
Link Settings	
Child Lock	
DVB-C Tuning Menu	
Language	
Display Settings	
Common Interface	
System Menu	Access

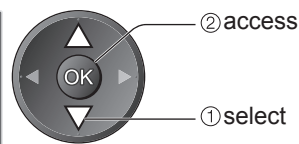

4 Select "Shipping Condition"

System Menu	
Shipping Condition	Access
System Update	
Software Licence	
System Information	

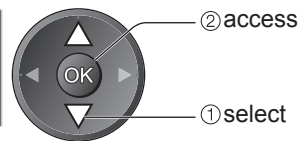

■ **To return to TV**
EXIT

5 Set

Restore Settings Shipping Condition

① Check the message and initialise

Shipping Condition	
All tuning data will be erased	
Are you sure?	OK (confirm)
Are you sure?	OK (confirm)
Confirm	OK (start Shipping Condition)

② Follow the on screen instructions

Reset to Factory Shipping Condition Completed.
Please switch off TV.

● "Auto Setup" will automatically start when Mains power On / Off switch is next turned On. (p. 12)

■ **To retune TV channels only, e.g. after moving house**
→ "Retuning from Setup Menu" (p. 32 and p. 33)

Updating the TV Software

From time to time, a new version of software may become available for download to enhance the performance or operations of the TV.

If there is an update available, a notification banner is displayed when the channel has the update information.

- To download →
- If you choose not to download →

You can update any new software automatically or update manually.

- 1 Display the menu**
MENU
- 2 Select "Setup"**
Main Menu
Picture
Sound
Setup
- 3 Select "System Menu"**
Setup Menu 1/2
Timer Programming
Off Timer Off
Link Settings
Child Lock
DVB-C Tuning Menu
Language
Display Settings
Common Interface
System Menu Access
- 4 Select "System Update"**
System Menu
Shipping Condition
System Update Access
Software Licence
System Information
- 5 Set**

■ To return to TV



Update TV's software system **System Update**

■ To update automatically

Select "Auto Update Search in Standby"

- Every time you set, the TV automatically performs a search in standby and downloads an update, if any software updates are available.
- The automatic updating is performed under the following conditions:
 - Standby (TV turned Off with the remote control)
 - Timer Programming or Direct TV Recording is not in progress.

If System Update is performed, the software will be updated (it may change TV functions). If you do not wish to do so, set "Auto Update Search in Standby" to "Off".

■ To update immediately

Select "System Update Search Now"

Searches for an update (for several mins.) and displays a corresponding message if any

Download



Note

- This function does not work on TH-32LRG20E.
- Download may take for about 60 mins.
- During software download and update, DO NOT switch Off the TV.
- The message might be the notification beforehand. In this case, the schedule information (the date that the new version can be used) will appear. You can set the reservation for update. The update will not start when the TV is set to Off.

Displaying PC Screen on TV

The screen of the PC connected to the TV can be displayed on the TV.
You can also listen to PC sound with the audio cable connected.

● To connect PC → p. 59



1 Select the external input
AV

2 Select "PC"

Input Selection
AV1/S
AV2
COMPONENT
PC
HDMI1
HDMI2
TV

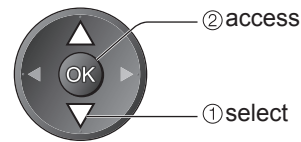

- Corresponding signals → p. 64
- If "H-freq." or "V-freq." is shown in red, the signals may not be supported.

■ To return to TV
→ TV

■ PC menu setting (changed as desired)

● To make settings → "How to Use Menu Functions" ① to ④ (p. 25)

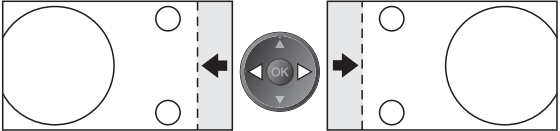
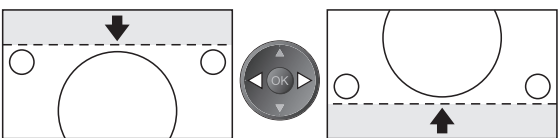
Menu	Item	Adjustments / Configurations (options)	
Picture	Advanced PC Settings	R-Gain	Adjusts the white balance for red areas
		G-Gain	Adjusts the white balance for green areas
		B-Gain	Adjusts the white balance for blue areas
		R-Cutoff	Adjusts the white balance for red areas
		G-Cutoff	Adjusts the white balance for green areas
		B-Cutoff	Adjusts the white balance for blue areas
		Gamma	Switches the gamma curve (1.8 / 2.0 / 2.2 / 2.4 / 2.6)
		Reset to Defaults	Press the OK button to reset to the default Advanced PC Settings
Setup	PC Setup	Input Resolution	Switches to a wide view ● VGA (640 × 480 pixels), WVGA (852 × 480 pixels), XGA (1,024 × 768 pixels), WXGA (1,280 × 768 pixels, 1,366 × 768 pixels) ● Options change depending on signals
		Clock	Set to the minimum level if noise occurs
		H-pos	Adjusts horizontal position 
		V-pos	Adjusts vertical position 
		Clock Phase	Eliminates flicker and distortion ● Adjust after Clock adjustment ● Set to the minimum level if noise occurs
		Sync	Chooses another synchronous signal if the image is distorted (H & V / On Green) ● H & V : by the horizontal and vertical signals from your PC On Green : by the green signal from your PC (if available)
		Reset to Defaults	Press the OK button to reset to the default PC Setup settings

● Other items → p. 26 - 31

Note

● For HDMI-compatible PC, possible to connect to HDMI terminals (HDMI1 / HDMI2) by using HDMI cable (p. 63).

● Displaying PC Screen on TV
● Updating the TV Software

Advanced

Using Media Player

Viewing from SD Card (VIERA IMAGE VIEWER)

Photo mode : Still pictures recorded by digital cameras will be displayed.

Video mode : Moving pictures recorded by digital video cameras will be played back.

- During the operation, audio signal is output from AV1, AUDIO OUT and DIGITAL AUDIO OUT terminals. But no video signals are output. AV1 can output audio signal if "AV1 out" is set to "Monitor" in the Setup Menu (p. 28).
- "Date" shows the date on which the recording was made by the digital camera or digital video camera. The file without record of the date is shown "***/**/****".
- For details on SD Cards → p. 61

■ To insert the SD Card
Gently insert the SD Card label surface facing front.

Label surface
Cutout

Push until a click is heard

■ To remove the SD Card

Push the centre of the card

Photo mode

Photo mode will read all ".jpg" extension files in the card.



1 Insert the SD Card and start Media Player

2 Select "Photo"

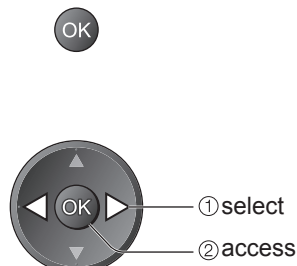
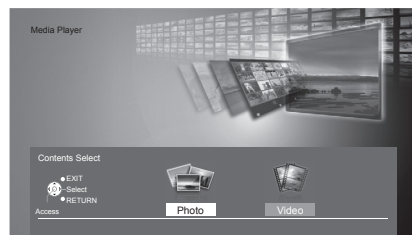

- You can also access Photo mode directly by using VIERA TOOLS.
- "How to Use VIERA TOOLS" (p. 24)

Error display (images that could not be loaded, etc.)



(Thumbnail - All photos)

The thumbnail of all the photos in the SD Card will be displayed.

- To change the back ground music → "Photo Setup" (p. 47)
- To display the information of the highlighted photo

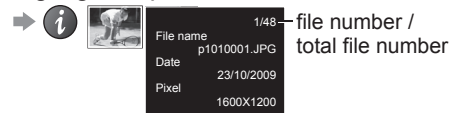

■ Single view - Displayed one at a time

Select the file from the thumbnail of photos to be viewed

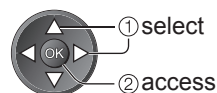

Operation guide (Single view)

- To display / hide the operation guide → **i**

• To operate Single view

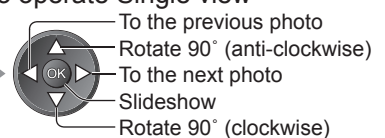

- To return to thumbnail → **RETURN**

■ To return to TV



■ To return to the previous screen



■ Slideshow - Slideshow will be completed within the thumbnail from which it was started.

Select the file from the thumbnail of photos for the first view



Start Slideshow



- To display / hide the operation guide → **i**

- To pause (return to Single view) → **OK**

- To return to thumbnail → **RETURN**

Photo Setup

Setup the settings for Photo mode.

Display the menu



Select "Photo Setup"

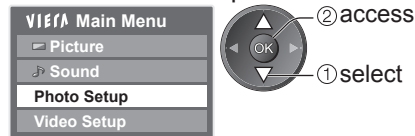

Select the items and set

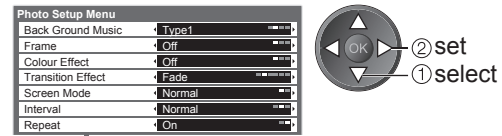

● Other items → p. 26 – 27 and p. 49

Menu	Item	Adjustments / Configurations (alternatives)
Photo Setup	Back Ground Music	Selects the back ground music during the Photo mode (Off / Type1 / Type2 / Type3) ● Type1, Type2 and Type3 are the fixed music each installed in this TV.
	Frame	Selects the indication frame of the slideshow (Off / Multi / Collage) Multi : 9 division display like tiled design Collage: A photo is displayed at random position and random scale.
	Colour Effect	Selects the colour effect of photos on Single view and Slideshow (Off / Sepia / Gray scale)
	Transition Effect	Selects the transition effect for switching the photo during the slideshow (Off / Fade / Slide / Dissolve / Motion / Random) Fade : The next photo fades in gradually. Slide : The next photo slides and appears from the left side. Dissolve : The photo is replaced by an indefinite block unit. Motion : The photo is replaced with enlarged, reduced, moved up or moved down. Random : Each transition is selected at random. ● This function is available when "Frame" is set to "Off".
	Screen Mode	Selects whether enlarged or normal viewing on Single view and Slideshow (Normal / Zoom) ● Depending on the photo size, the photo may not be enlarged.
	Interval	Selects slideshow interval (Short / Normal / Long)
	Repeat	Slideshow repeat (Off / On)

Change to the Video mode

You can switch to the Video mode of Media Player from the thumbnail.

While the thumbnail is displayed, display the contents selection



Select "Video"



● For details of the Video mode operations
→ "Video mode" (p. 48)

■ To sort by folder, recorded date or recorded month

Display the view selection



Select the sort type

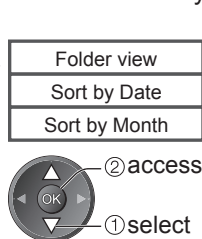

Displays the thumbnail grouped by folder
● The files which are not into a folder will be collected to the folder named "I".

Displays the thumbnail grouped by the same date
● The group of the photos without recorded date is shown as "Unknown".

Displays the thumbnail grouped by the same month
● The group of the photos without recorded date is shown as "Unknown".

Select one of the sorted group to display the thumbnail of the selected group

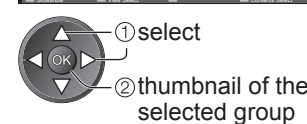
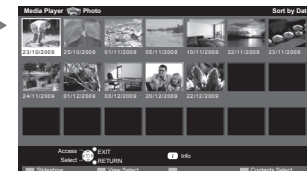

● To display the information of the highlighted group

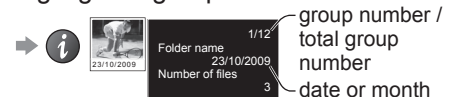

● To return to the thumbnail of all photos

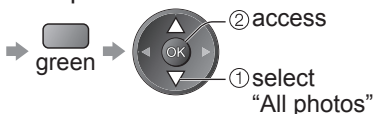

Using Media Player

Viewing from SD Card (VIERA IMAGE VIEWER)

Video mode

Video mode supports AVCHD and MPEG2 file formats.



1 Insert the SD Card and start Media Player

2 Select "Video"

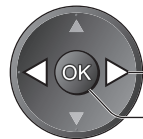
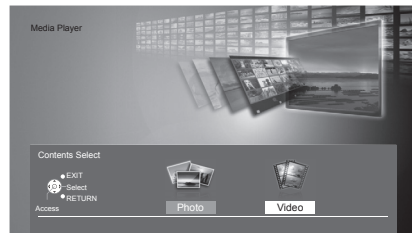

① select
② access

- You can also access Video mode directly by using VIERA TOOLS
→ "How to Use VIERA TOOLS" (p. 24)

Error display (images that could not be loaded, etc.)

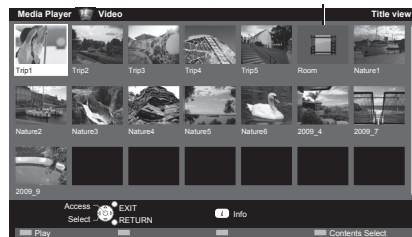

(Thumbnail - Title view)

The thumbnail of video titles in the SD Card will be displayed.

The preview will start when the title is highlighted if it supports a preview.

- To off the preview → "Video Setup" (p. 49)
- To display the information of the highlighted title

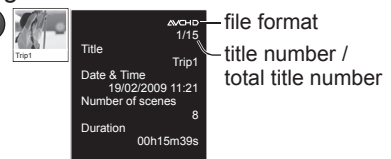

■ Playback from Title view

Playback of the selected title will start.
Select the title Start playback



■ Playback from the selected scene in the title

Playback will start from the selected scene to the end of the title.
Select the title Select the scene to start playback

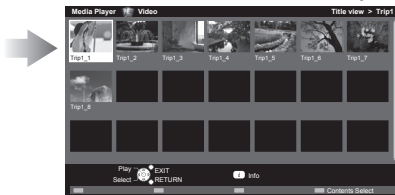
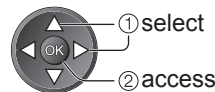

(Thumbnail - Scene view)

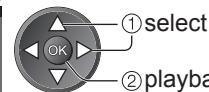

The preview will start when the scene is highlighted if it supports a preview.

- To off the preview → "Video Setup" (p. 49)

■ To return to TV



■ To return to the previous screen



- To repeat playback → "Video Setup" (p. 49)

- To display the information of the highlighted scene

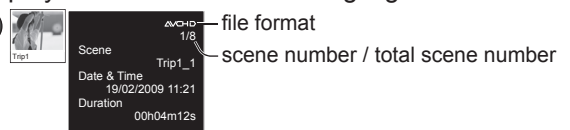

■ How to operate in the playback

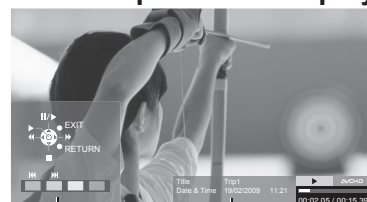

Operation guide (Playback)
information banner

- To change aspect (only for the 4:3 video content)
→ ASPECT



- To return to thumbnail → RETURN

- To display / hide the operation guide and information banner → i

- To operate the playback

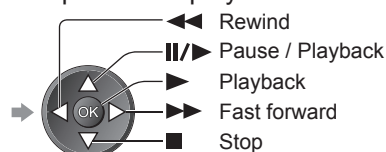

- To the previous scene → red

- To the next scene → green

Sound Settings

You can enjoy the multi-channel sound via an amplifier connected to DIGITAL AUDIO OUT terminal.

To confirm or change the current sound status (during playback)

Display the Option menu

Change the sound (if the video has multiple audio signals)

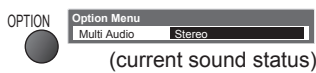

It may take several seconds to change the sound.

Audio output settings

Display the menu

Select "Sound"

Select "SPDIF Selection" and set

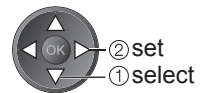
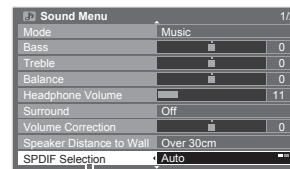
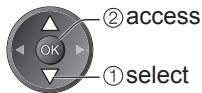
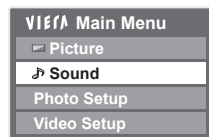

Menu	Item	Adjustments / Configurations (alternatives)
Sound	SPDIF Selection	SPDIF : A standard audio transfer file format Selects the initial setting for digital audio output signal from DIGITAL AUDIO OUT terminal (Auto / PCM) Auto: Dolby Digital is output as Dolby Digital Bitstream. MPEG is output as PCM. PCM: Digital output signal is fixed to PCM.

Video Setup

Setup the settings for Video mode.

Display the menu

Select "Video Setup"

Select "Other Settings"

Select the items and set

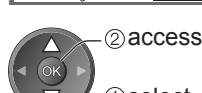
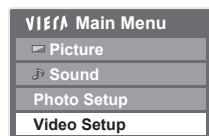

Other items
➔ p. 26 – 27 and p. 47

Display Settings
➔ p. 30

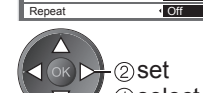

16:9 Overscan
➔ p. 31

Menu	Item	Adjustments / Configurations (alternatives)
Video Setup	Other Settings	
	Video Preview	Sets to start the preview of the title or scene in the thumbnail screen (Off / On) Image may not be displayed for an instant in the thumbnail screen. Set the preview "Off" to resolve this.
	Repeat	Playback repeat within the title (Off / On)

Change to the Photo mode

You can switch to the Photo mode of Media Player from the thumbnail.

While the thumbnail is displayed, display the contents selection

Select "Photo"

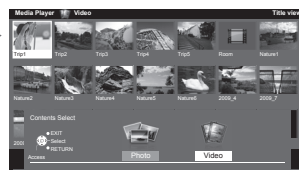

For details of the Photo mode operations
➔ "Photo mode" (p. 46)

Note

The structure of titles and scenes may vary depending on the digital video camera used.

Link Functions (Q-Link VIERA Link)

Q-Link connects the TV and DVD Recorder / VCR, and enables easy recording, playback, etc. (p. 52)
 VIERA Link (HDAVI Control™) connects the TV and the equipment with VIERA Link function, and enables easy control, convenient recording, playback, energy saving, creating home theatre, etc., without complicated setting. (p. 53 - 57)

You can use Q-Link and VIERA Link functions together.

- This TV supports "HDAVI Control 5" function. But available features are depending on the connected equipment's version of HDAVI Control. Please refer to the manual of the equipment to confirm the version.
- VIERA Link features may be available even with other manufacturers' equipment supporting HDMI CEC.

Summary of Q-Link and VIERA Link features

■ Q-Link (SCART connection only)

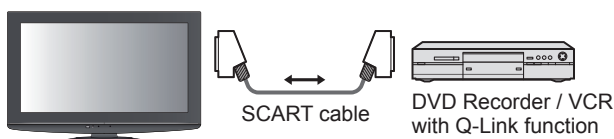
Features	Connected equipment DVD Recorder / VCR with Q-Link function	Connection
Preset download	○	 <p>● Use fully wired SCART cable. ● Connect the DVD Recorder / VCR supporting Q-Link to the TV's AV1 terminal via a SCART cable.</p>
Easy playback	○	
Power on link	○	
Power off link	○	
Direct TV Recording	○	

■ VIERA Link (HDMI connection only)

Features	Connected equipment DIGA Recorder with VIERA Link function	DVD Player / Blu-ray Disc Player with VIERA Link function	HD Video Camera / LUMIX Camera with VIERA Link function
Preset download	○*2	-	-
Easy playback	○	○	○
Power on link	○	○	○
Power off link	○	○	○
Reduce unnecessary power consumption in standby	○*3	○*3	-
Auto standby for unnecessary equipment	○*3	○*3	-
Pause Live TV programme	○*2 ○*4	-	-
Direct TV Recording	○*2	-	-
Control the menu of the connected equipment by VIERA remote control	○*1	○*1	○*1
Speaker control	-	-	-

Connection

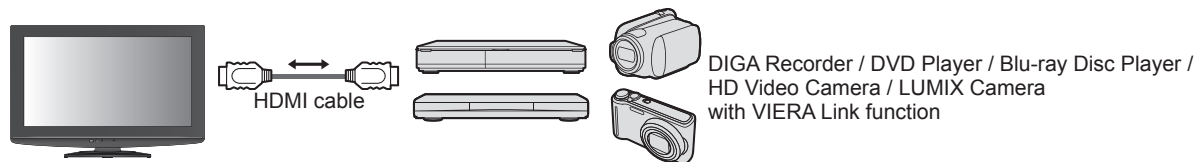

- Use fully wired HDMI compliant cable.
- Connect the equipment supporting VIERA Link to the TV's HDMI1 or HDMI2 terminal via an HDMI cable.
- About HDMI cable for connecting Panasonic HD Video Camera or LUMIX Camera, read the manual of the equipment.

■ VIERA Link (HDMI and SCART connections)

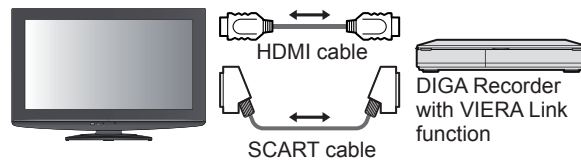
Features	Connected equipment DIGA Recorder with VIERA Link function	Connection
Preset download	○	 <p>● Use fully wired HDMI compliant cable. ● Connect the equipment supporting VIERA Link to the TV's HDMI1 or HDMI2 terminal via an HDMI cable. ● Use fully wired SCART cable. ● Connect the equipment supporting VIERA Link to the TV's AV1 terminal via a SCART cable.</p>
Easy playback	○	
Power on link	○	
Power off link	○	
Reduce unnecessary power consumption in standby	○*3	
Auto standby for unnecessary equipment	○*3	
Pause Live TV programme	○*2 ○*4	
Direct TV Recording	○*2	
Control the menu of the connected equipment by VIERA remote control	○*1	
Speaker control	-	

■ VIERA Link (HDMI and Audio out connections)

Features	Connected equipment	Player theatre with VIERA Link function	Blu-ray Disc theatre with VIERA Link function	Amplifier with VIERA Link function
Preset download		—	—	—
Easy playback		○*5	○*5	—
Power on link		○	○	—
Power off link		○	○	○
Reduce unnecessary power consumption in standby		—	○*3	—
Auto standby for unnecessary equipment		○*3 ○*6	○*3 ○*6	○*3
Pause Live TV programme		—	—	—
Direct TV Recording		—	—	—
Control the menu of the connected equipment by VIERA remote control		○*1	○*1	—
Speaker control		○	○	○

Connection

- To use Player theatre / Blu-ray Disc theatre:

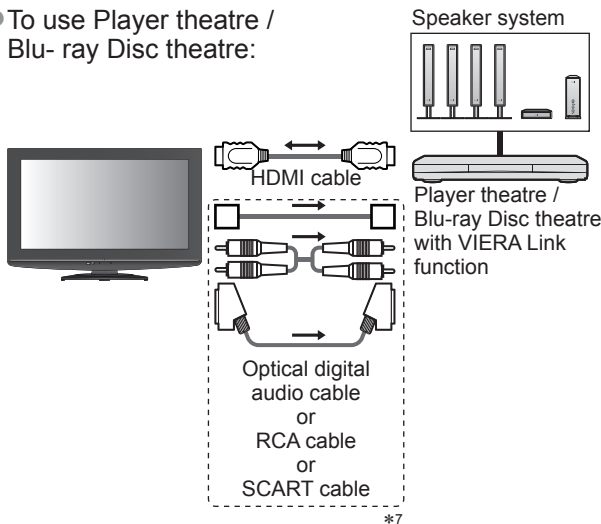

- To use Amplifier:

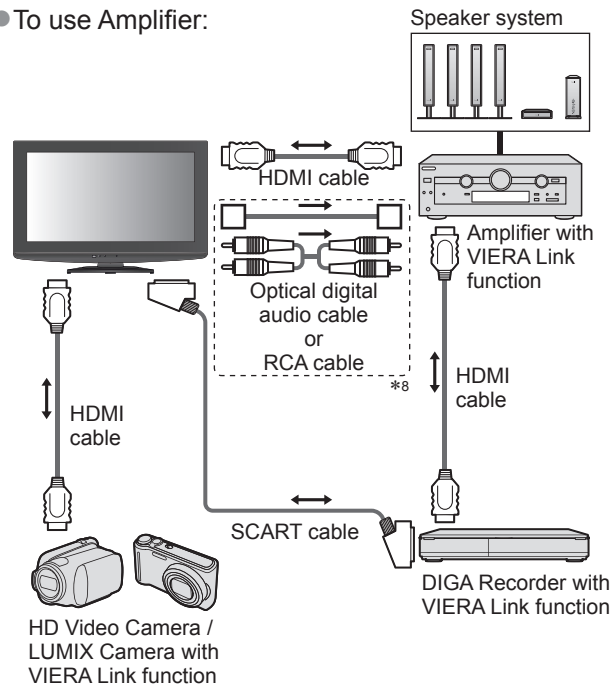

- Use fully wired HDMI compliant cable.
- Connect the equipment supporting VIERA Link to the TV's HDMI2 terminal via an HDMI cable.
- Use fully wired SCART cable.
- If you use a SCART cable for audio output, connect the equipment supporting VIERA Link to the TV's AV1 terminal and set "AV1 out" to "Monitor" in the Setup Menu (p. 28).
- Use any one of the optical digital audio cable, RCA cable and SCART cable for audio output from the TV.

*1: Available with the equipment which has "HDAVI Control 2 or later" function.

*2: Available with the equipment which has "HDAVI Control 3 or later" function.

*3: Available with the equipment which has "HDAVI Control 4 or later" function.

*4: Available with DIGA Recorder which has HDD.

*5: while playingback a disc

*6: except for watching a disc

*7: If the connected equipment has "HDAVI Control 5" function, you do not have to use this audio cable (Optical digital audio cable, RCA cable or SCART cable). In this case, connect the equipment to the TV's HDMI2 terminal via an HDMI cable.

*8: If the connected equipment has "HDAVI Control 5" function, you do not have to use this audio cable (Optical digital audio cable or RCA cable). In this case, connect the equipment to the TV's HDMI2 terminal via an HDMI cable.

■ VIERA Link Control of compatible equipment (VIERA Link Control → p. 56)

- Table below displays maximum number of compatible equipment that can be controlled by VIERA Link Control. This includes connections to equipment already connected to the TV.

For example, DIGA Recorder connected to Amplifier which is connected to the TV via an HDMI cable.

Type of the equipment	Maximum number
Recorder (DIGA Recorder, etc.)	2
Player (DVD Player, Blu-ray Disc Player, HD Video Camera, LUMIX Camera, Digital Camera, Player theatre, Blu-ray Disc theatre, etc.)	2
Audio system (Player theatre, Blu-ray Disc theatre, Amplifier, etc.)	1
Tuner (Set top box, etc.)	3

Link Functions (Q-Link VIERA Link)

Q-Link

■ Preparations

- Connect the DVD Recorder / VCR with the following logos: "Q-Link", "NEXTVIEWLINK", "DATA LOGIC", "Easy Link", "Megalogic" or "SMARTLINK"
- Q-Link connection → p. 50
- Use fully wired SCART cable.
- Set up the DVD Recorder / VCR. Read the manual of the recorder.
- Download preset - channel, language, country / region settings → "Preset download" (see below)

■ Features available

Preset download

Channel, language, country / region settings can be downloaded to the recorder.

- DVB-C channel setting cannot be downloaded.
- To download settings → "Download" (p. 28) or "Auto Setup" (p. 33) or "Auto Setup" - when first using the TV (p. 12 and p. 13)

Direct TV Recording - What you see is What you record

Recording the current programme in DVD Recorder / VCR immediately.



- Available conditions:

Current mode	Using tuner	How to record
Analogue	TV	TV monitor out
	Recorder	Recorder's tuner
DVB	TV	TV monitor out
AV (watching recorder's tuner)	Recorder	Recorder's tuner
AV (watching recorder's external input)	—	Recorder's external input
AV (watching TV's external input)	—	TV monitor out

- When Direct TV Recording is performed, the recorder is automatically turned on if it is in Standby mode.
- Changing channel or turning off the TV is available while the recorder is recording from its own tuner.
- Changing channel is not available while the recorder is recording from the TV tuner.

■ To stop recording

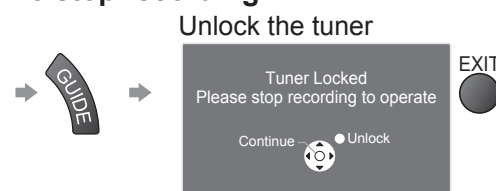

Power on link and Easy playback

Set Power on Link "On" in the Setup Menu to use this function → "Power on Link" (p. 28)

When DVD Recorder / VCR starts playback or direct navigator / function menu for the equipment are activated, the TV is turned on and input mode is switched automatically so that you can view the content. (Only when the TV is in Standby mode.)

Power off link

Set Power off Link "On" in the Setup Menu to use this function → "Power off Link" (p. 28)

When TV is set to Standby mode, the recorder is also automatically set to Standby. (Only when the videocassette or disc is not active.)

- This function will work even if the TV enters Standby mode automatically by auto power standby function.

- "DATA LOGIC" (a trademark of Metz Corporation)
- "Easy Link" (a trademark of Philips Corporation)

- "Megalogic" (a trademark of Grundig Corporation)
- "SMARTLINK" (a trademark of Sony Corporation)

Note

- Some recorders are not applicable. Read the manual of the recorder.

VIERA Link “HDAVI Control™”*

*Enjoy additional HDMI Inter-Operability with Panasonic products which have “HDAVI Control” function. This TV supports “HDAVI Control 5” function.

Connections to the equipment (DIGA Recorder, HD Video Camera, Player theatre, Amplifier, etc.) with HDMI and SCART cables allow you to interface them automatically (p. 50 and p. 51).

These features are limited to models incorporating “HDAVI Control” and “VIERA Link”.

- Some functions are not available depending on the equipment’s version of HDAVI Control. Please confirm the connected equipment’s version of HDAVI Control.
- VIERA Link “HDAVI Control”, based on the control functions provided by HDMI which is an industry standard known as HDMI CEC (Consumer Electronics Control), is a unique function that we have developed and added. As such, its operation with other manufacturers’ equipment that supports HDMI CEC cannot be guaranteed.
- Please refer to individual manuals for other manufacturers’ equipment supporting VIERA Link function.
- About applicable Panasonic equipment, consult your local Panasonic dealer.

■ Preparations

- Connect the equipment supporting VIERA Link.
- VIERA Link connection → p. 50 and p. 51
- Use fully wired HDMI compliant cable. Non-HDMI-compliant cables cannot be utilized.
Recommended Panasonic’s HDMI cable part number:
 - RP-CDHS15 (1.5 m)
 - RP-CDHS30 (3.0 m)
 - RP-CDHS50 (5.0 m)
- Use fully wired SCART cable.
- Set up the connected equipment. Read the manual of the equipment.
- For optimal recording, the settings of the recorder may need to be changed. For details, read the manual of the recorder.
- Download preset - channel, language, country / region settings → “Preset download” (see below)
- Set VIERA Link On in the Setup Menu → “VIERA Link” (p. 28)
- Set up the TV
 - ➔ **After connection, turn the equipment on and then switch the TV on. Select the input mode to HDMI1 or HDMI2 (p. 22), and make sure that an image is displayed correctly.**
This setup should be done each time when the following conditions occur:
 - for the first time
 - when adding or reconnecting equipment
 - when changing setup

■ Features available

Preset download

Channel, language, country / region settings can be downloaded to the recorder.

- DVB-C channel setting cannot be downloaded.
- To download settings → “Download” (p. 28) or “Auto Setup” (p. 33) or “Auto Setup” - when first using the TV (p. 12 and p. 13)

Easy playback

Automatic Input switching - When the connected equipment is operated, input mode is switched automatically. When it is stopped operating, input mode is returned.

Power on link

Set Power on Link “On” in the Setup Menu to use this function → “Power on Link” (p. 28)

When the connected equipment starts playback or direct navigator / function menu for the equipment are activated, the TV is automatically turned on. (Only when the TV is in Standby mode.)

Power off link

Set Power off Link “On” in the Setup Menu to use this function → “Power off Link” (p. 28)

When the TV is set to Standby mode, the connected equipment is also automatically set to Standby.

- This function will work even if the TV enters Standby mode automatically by auto power standby function.

Link Functions (Q-Link VIERA Link)

■ Features available

Reduce unnecessary power consumption in standby **Standby Power Save**

Set Standby Power Save “On” in the Setup Menu to use this function

➔ “Standby Power Save” (p. 28)

The power consumption in Standby mode of the connected equipment is controlled higher or lower in synchronization with the TV On / Off state to reduce the consumption.

When the TV is set to Standby mode, the connected equipment is automatically set to Standby and the power consumption in Standby mode of the connected equipment is automatically minimized.

When the TV is turned on, the connected equipment is still in Standby mode, but the power consumption is increased to make startup time early.

- This function is effective if the connected equipment can change the power consumption in Standby mode and is set to higher consumption.
- This function will work when “Power off Link” is set to “On”.

Auto standby for unnecessary equipment **Intelligent Auto Standby**

Set Intelligent Auto Standby “On (With reminder)” or “On (No reminder)” in the Setup Menu to use this function

➔ “Intelligent Auto Standby” (p. 28)

When the TV is On, non-watched or non-used connected equipment goes into Standby mode automatically to reduce the power consumption. For example, when the input mode is switched from HDMI, when Speaker Selection is changed to “TV” (except for watching a disc).

- If you select “On (With reminder)”, the on screen message will be displayed to be noticed before working this function.
- This function may not work properly depending on the connected equipment. If required, set to “Off”.

■ Features available (Using VIERA Link Menu)

Direct TV Recording - What you see is What you record **Direct TV Rec**

Recording the current programme in DIGA Recorder immediately.

- If you connect a variety of recorders including other manufacturers’ recorders at the same time, please connect DIGA Recorder to the TV’s lower HDMI terminal number. For example, if you use HDMI1 and HDMI2 for two recorders, in this case connect DIGA Recorder to HDMI1.
- If you cannot operate, check the settings and the equipment
 - ➔ “Summary of Q-Link and VIERA Link features” (p. 50 and p. 51), “Preparations” (p. 53)
- If you wish to record the programme which DIGA Recorder does not support, SCART connection is required and the programme is recorded by Q-Link function (p. 52).
- Depending on the programme, SCART connection may be required to record.
- Changing channel or turning off the TV is available while the recorder is recording from its own tuner.
- Changing channel is not available while the recorder is recording from the TV tuner.



1 Display “VIERA Link Menu”

2 Select “Direct TV Rec” and start recording

VIERA Link Menu	
Pause Live TV	Start
Direct TV Rec	Start
VIERA Link Control	Recorder
Speaker Selection	Home Cinema

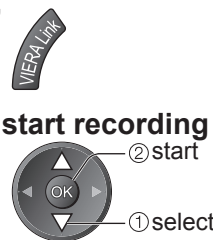

- You can also start recording directly ➔

■ To stop recording

Select “Stop” in “Direct TV Rec” and access

VIERA Link Menu	
Pause Live TV	Start
Direct TV Rec	Stop
VIERA Link Control	Recorder
Speaker Selection	Home Cinema

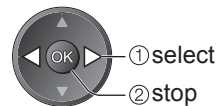

- You can also stop recording directly.
Unlock the tuner

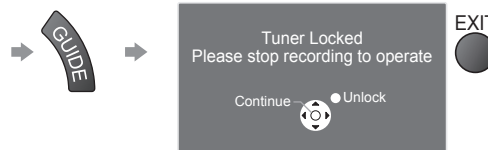

■ **Features available** (Using VIERA Link Menu)

Pause Live TV programme Pause Live TV

You can pause the live TV programme and resume later.

Live TV programme will be recorded on HDD of the connected DIGA Recorder.

- This function is available with DIGA Recorder which has HDD.
- If you connect a variety of recorders including other manufacturers' recorders at the same time, please connect DIGA Recorder which has HDD to the TV's lower HDMI terminal number. For example, if you use HDMI1 and HDMI2 for two recorders, in this case connect DIGA Recorder which has HDD to HDMI1.
- If you cannot operate, check the settings and the equipment
 - ➔ "Summary of Q-Link and VIERA Link features" (p. 50 and p. 51), "Preparations" (p. 53)

Access and pause the live TV programme



1

Display "VIERA Link Menu"



2

Select "Pause Live TV" and pause

VIERA Link Menu	
Pause Live TV	Start
Direct TV Rec	Start
VIERA Link Control	Recorder
Speaker Selection	Home Cinema

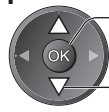

② pause
① select

The TV picture will be paused.

- You can also pause directly by using VIERA TOOLS
 - ➔ "How to Use VIERA TOOLS" (p. 24)
- Live TV programme is recorded on HDD from where it was paused.
- If the paused TV picture disappears after a few minutes
 - ➔ OPTION (the paused picture will be restored)
- Follow the operation guide to operate Pause Live TV function.

■ **To operate Pause Live TV**

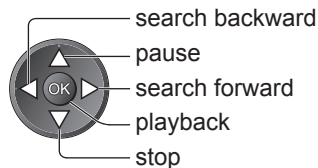

- Operations may be different depending on the recorder. In this case, follow the operation guide or read the manual of the recorder.

- If you stop playback, the recorded programme will be deleted from HDD.

■ **To return to Live TV**

(stop playback of Pause Live TV / cancel pause)

Select "Yes"



Pause Live TV	
Stop Pause Live TV?	
Yes	No



① select
② stop

- If you stop playback or cancel pause, the recorded programme will be deleted from HDD.

Link Functions (Q-Link VIERA Link)

■ Features available (Using VIERA Link Menu)

Control the menu of the connected equipment by VIERA remote control

VIERA Link Control

You can control some functions of the connected equipment with this TV remote control (point the remote control at the TV's signal receiver).

- If you cannot operate, check the settings and the equipment
 - ➔ "Summary of Q-Link and VIERA Link features" (p. 50 and p. 51), "Preparations" (p. 53)
- For details of the operations for the connected equipment, read the manual of the equipment.

Access and operate the menu of the equipment



1 Display "VIERA Link Menu"

2 Select "VIERA Link Control"

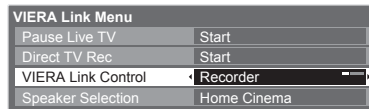

3 Select the equipment you want to access

The type of the connected equipment is displayed. Select the type of the equipment and access.

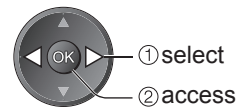
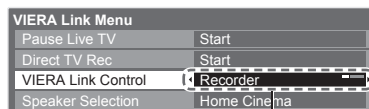

Recorder / Player / Home Cinema / Video Camera / LUMIX / Digital Camera / Other

- You can also access directly by using VIERA TOOLS
 - ➔ "How to Use VIERA TOOLS" (p. 24)
- The displayed item may vary depending on the connected equipment.
- "Home Cinema" means Player theatre, Blu-ray Disc theatre or Recorder theatre.
- "Other" means Tuner set top box.

The menu of the accessed equipment
(Input mode will be changed automatically)

4 Operate the menu of the equipment

Available VIERA remote control buttons:
(depending on the connected equipment)



① Set the code of the remote control to "73"

➔ "How to change the code for the type of the equipment" (p. 23)

② Follow the operation guide

● To display the operation guide ➔
 If other manufacturers' equipment is accessed, Setup / Contents Selection menu may be displayed.

● When the key words are displayed on colour bar



Note

- Some operations may not be available depending on the equipment. In this case use its own remote control to operate the equipment.

■ If multiple recorders or players are connected



Recorder1-2 / Player1-2

The number is given from the TV's lower HDMI terminal number connected to the same type equipment. For example, two recorders to HDMI1 and HDMI2, in this case the recorder connected to HDMI1 is displayed as "Recorder1", and the recorder connected to HDMI2 is displayed as "Recorder2".

■ If you access non-VIERA Link equipment



The type of the connected equipment is displayed. You can access the menu of the equipment. But you cannot operate it. Use its own remote control to operate the equipment.

■ **Features available** (Using VIERA Link Menu)

Speaker control **Speaker Selection**

You can control the theatre speaker with this TV remote control (point the remote control at the TV's signal receiver).

- If you cannot operate, check the settings and the equipment
 - ➔ "Summary of Q-Link and VIERA Link features" (p. 50 and p. 51), "Preparations" (p. 53)

Access and control the speaker volume

1 Display "VIERA Link Menu"

2 Select "Speaker Selection"

VIERA Link Menu	
Pause Live TV	Start
Direct TV Rec	Start
VIERA Link Control	Recorder
Speaker Selection	Home Cinema

3 Set to "Home Cinema" or "TV"

■ **Home Cinema**

Player theatre, Blu-ray Disc theatre or Amplifier will be automatically turned on if it is in Standby mode and the sound is from theatre speakers connected to the equipment.

- Volume up / down

➔ (Volume slide bar will be displayed when adjusting the volume of the equipment.)

- Mute ➔

- The sound of TV speakers is mute.
- When the equipment is turned off, TV speakers will be active.

■ **TV**

TV speakers are active.

Note

- If you wish to enjoy the multi-channel sound (e.g. Dolby Digital 5.1ch) via an Amplifier, connect with HDMI cable and Optical digital audio cable (p. 51), and then select "Home Cinema". If your Amplifier has "HDAVI Control 5" function, you can connect only with HDMI cable. In this case, connect your Amplifier to the TV's HDMI2 terminal.
To enjoy the sound from the DIGA Recorder in multi-channel sound, connect an HDMI cable from the DIGA Recorder to the Amplifier (p. 51).

Note

- These functions may not work properly depending on the connected equipment.
- Image or sound may not be available for the first few seconds when Input mode is switched.
- Easy playback may be available by using the remote control for Player theatre, Blu-ray Disc theatre or Amplifier. Read the manual of the equipment.
- "HDAVI Control 5" is the newest standard (current as of December, 2009) for HDAVI Control compatible equipment. This standard is compatible with conventional HDAVI equipment.
- To confirm this TV's version of HDAVI Control ➔ "System Information" (p. 31)

External Equipment

These diagrams show our recommendations for connection of your TV to various pieces of equipment. For other connections, consult the instructions for each piece of equipment, the table below, and the specifications (p. 67).

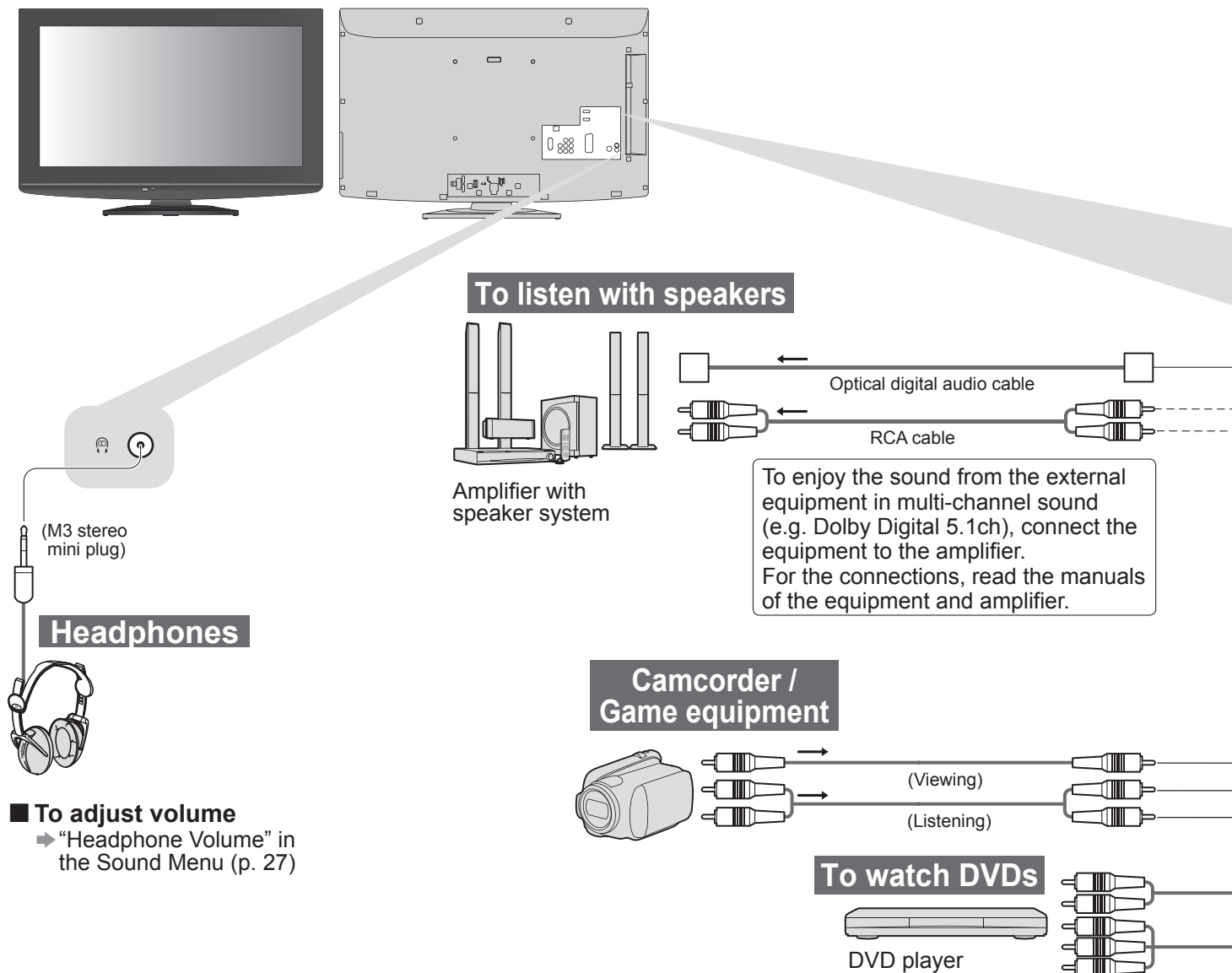

- **To adjust volume**
 - ➔ "Headphone Volume" in the Sound Menu (p. 27)

■ Types of connectable equipment to each terminal

Terminal	AV1	AV2	COMPONENT
Recording / Playback (equipment)			
To record / playback videocassettes / DVDs (VCR / DVD recorder)	○		
To watch DVDs (DVD player)	○	○	○
To watch camcorder images (Video camera)	○	○	
To watch satellite broadcasts (Set top box)	○	○	
To play games (Game equipment)	○	○	
To use amplifier with speaker system			
Q-Link	○		
VIERA Link	○ (with HDMI)		
Direct TV Recording	○		
Serial Control			

○: Recommended Connection

*1 : applicable if your amplifier has ARC (Audio Return Channel) function

Technical Information

Auto Aspect

The optimum size and aspect can be chosen automatically, and you can enjoy finer images. (p. 16)

■ Aspect Control Signal

“WIDE” will appear in the top left of the screen if a Widescreen signal (WSS) or a Control signal through SCART / HDMI terminal is found.

The aspect will switch to the appropriate 16:9 or 14:9 widescreen ratio.

This function will work in any aspect mode.

Input terminal	Input signal format	Aspect Control Signal	
		Widescreen signal (WSS)	Control signal through SCART (pin8) / HDMI terminal
Cable RF	DVB-C	○	
	DVB-T	○	
	PAL B, G, H, I	○	
	PAL D, K	○	
	SECAM B, G	○	
	SECAM L, L'	○	
	SECAM D, K	○	
	PAL 525/60 6.5 MHz	—	
	PAL 525/60 6.0 MHz	—	
	PAL 525/60 5.5 MHz	—	
	M.NTSC 6.5 MHz	—	
	M.NTSC 6.0 MHz	—	
	M.NTSC 5.5 MHz	—	
AV1 (Composite or S-Video) AV2	PAL	○	○
	SECAM	○	○
	PAL 525/60	—	○
	M.NTSC	—	○
	NTSC	—	○
COMPONENT	525 (480) / 60i	—	
	525 (480) / 60p	—	
	625 (576) / 50i	○	
	625 (576) / 50p	○	
	750 (720) / 60p	—	
	750 (720) / 50p	—	
	1,125 (1,080) / 60i	—	
	1,125 (1,080) / 50i	—	
HDMI1 HDMI2	525 (480) / 60i	—	○
	525 (480) / 60p	—	○
	625 (576) / 50i	—	○
	625 (576) / 50p	—	○
	750 (720) / 60p	—	○
	750 (720) / 50p	—	○
	1,125 (1,080) / 60i	—	○
	1,125 (1,080) / 50i	—	○
	1,125 (1,080) / 60p	—	○
	1,125 (1,080) / 50p	—	○
	1,125 (1,080) / 24p	—	○

■ Auto mode

Auto mode determines the best aspect ratio to fill the screen. It does this using a four step process (WSS, Control signal through SCART / HDMI terminal, Letterbox detection, or Justify to fill the screen) to determine.

This process may take several minutes, depending on the darkness of the image.

Letterbox detection: If black bands at the top and bottom of the screen are detected, Auto mode chooses the best ratio and expands the image to fill the screen.

If no aspect signals are detected, Auto mode enhances the image for optimum viewing pleasure.

Note

- The ratio varies depending on the programme, etc. If the ratio is out of the standard 16:9, black bands at the top and bottom of the screen may appear.
- If the screen size looks unusual when a widescreen-recorded programme is played back on a VCR, adjust the tracking of the VCR. Read the manual of the VCR.

SD Card

Use an SD Card which meets SD standards.
If not, it may cause the TV to malfunction.

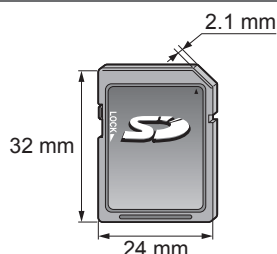

■ Cautions in handling SD Card

- Do not remove the card while the TV is accessing data (this can damage card or TV).
- Do not touch the pins on the back of the card.
- Do not subject the card to a high pressure or impact.
- Insert the card in the correct direction (otherwise, card may be damaged).
- Electrical interference, static electricity, or erroneous operation may damage the data or card.
- Back up the recorded data at regular intervals in case of deteriorated or damaged data or erratic operation of the TV. (Panasonic is not liable for any deterioration or damage of recorded data.)

■ Data format for Card browsing

- Photo : Still images recorded with digital still cameras compatible with JPEG files of DCF* and EXIF standards
Data format - Baseline JPEG (Sub-sampling 4:4:4, 4:2:2 or 4:2:0)
Image resolution - 8 × 8 to 30,719 × 17,279 pixels
- Video : SD-Video Standard Ver. 1.2 [MPEG-2 (PS format)] and AVCHD Standard compatible files with an audio format that is either MPEG-1/Layer-2 format or Dolby Digital format
(Files recorded with vertical frequency 50 Hz are applicable. A modified data with a PC may not be displayed correctly.)
- Card format : SDXC Card - exFAT
SDHC Card / SD Card - FAT16 or FAT32
- Compliant card type (maximum capacity): SDXC Card (64 GB), SDHC Card (32 GB), SD Card (2 GB), miniSD Card (2 GB) (requiring miniSD adapter)
- If miniSD Card is used, insert / remove it together with the adapter.
- Check the latest information on the card type at the following website. (English only)
<http://panasonic.jp/support/global/cs/>

*DCF (Design rule for camera file system): Unified standard established by Japan Electronics and Information Technology Industries Association (JEITA).

Note

- Format the card with the recording equipment.
- The picture may not appear correctly on this TV depending on the recording equipment used.
- Display may take some time when there are many files and folders.
- This function cannot display Motion JPEG and still image not JPEG formatted (i.e. TIFF, BMP).
- A data modified with a PC may not be displayed.
- Images imported from a PC must be compatible with EXIF (Exchangeable Image File) 2.0, 2.1, and 2.2.
- Partly degraded files might be displayed at a reduced resolution.
- The folder and file names may be different depending on the digital camera or digital video camera used.
- Do not use two-byte characters or other special codes.
- The card may become unusable with this TV if the file or folder names are changed.

■ On screen messages

Message	Meaning / Action
Cannot read file	<ul style="list-style-type: none"> ● The file is broken or unreadable. ● The TV does not support the format. (For the applicable formats and data, see above.)
No SD card inserted	<ul style="list-style-type: none"> ● Confirm SD Card is inserted correctly.
No valid file to play	<ul style="list-style-type: none"> ● The card has no data.
Please confirm the SD card is OK	<ul style="list-style-type: none"> ● The inserted SD Card has a problem.
This operation is not possible	<ul style="list-style-type: none"> ● Your operation is not available.

Technical Information

Characters table for numeric buttons

You can enter characters by using numeric buttons for free input items.

Press the numeric button repeatedly until you reach the desired character.

- 1** **2**_{abc} **3**_{def} ● The character is set automatically if you leave for one second.
- 4**_{ghi} **5**_{jkl} **6**_{mno} ● You can also set the character by pressing the OK button or other numeric buttons within one second.
- 7**_{pqrs} **8**_{tuv} **9**_{wxyz}
- 0**



Characters table:

Numeric buttons	The number of times to press										
	1	2	3	4	5	6	7	8	9	10	11
1	.	1	!	:	#	+	-	*	_	()
2 _{abc}	a	b	c	2	A	B	C				
3 _{def}	d	e	f	3	D	E	F				
4 _{ghi}	g	h	i	4	G	H	I				
5 _{jkl}	j	k	l	5	J	K	L				
6 _{mno}	m	n	o	6	M	N	O				
7 _{pqrs}	p	q	r	s	7	P	Q	R	S		
8 _{tuv}	t	u	v	8	T	U	V				
9 _{wxyz}	w	x	y	z	9	W	X	Y	Z		
0	Space	0									

SCART and HDMI terminal information

■ AV1 SCART terminal (RGB, VIDEO, S-VIDEO, Q-Link)

AV1 - Pins 15 and 20 are dependent on AV1 S-VHS / VIDEO switching.

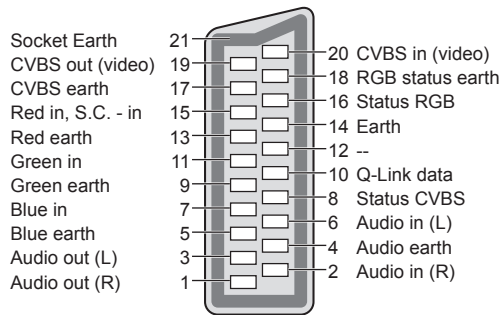

■ HDMI terminal

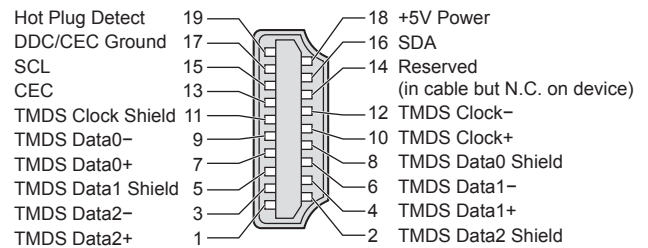

HDMI connection

HDMI (high-definition multimedia interface) is the world's first complete digital consumer AV interface complying with a non-compression standard.

HDMI allows you to enjoy high-definition digital images and high-quality sound by connecting the TV and the equipment.

HDMI-compatible equipment^(*1) with an HDMI or DVI output terminal, such as a DVD player, a set top box or a game equipment, can be connected to the HDMI terminal using an HDMI compliant (fully wired) cable.

About connections, see "External Equipment" (p. 58).

■Applicable HDMI features

- Input audio signal : 2ch Linear PCM (sampling frequencies - 48 kHz, 44.1 kHz, 32 kHz)
- Input video signal : 480i, 480p, 576i, 576p, 720p, 1080i and 1080p
 - ➔ "Input signal that can be displayed" (p. 64)
 - Match the output setting of the digital equipment.
- Input PC signal : ➔ "Input signal that can be displayed" (p. 64)
- Match the output setting of the PC.
- VIERA Link (HDAVI Control 5) : ➔ "VIERA Link" (p. 53)
- Audio Return Channel^(*3) (HDMI2 terminal only)

■DVI connection

If the external equipment has only a DVI output, connect to the HDMI terminal via a DVI to HDMI adapter cable^(*2). When the DVI to HDMI adapter cable is used, connect the audio cable to the audio input terminal (HDMI1 / 2: use COMPONENT-AUDIO terminals).

Note

- Audio settings can be made on the "HDMI1 / 2 Input" in the Sound Menu. (p. 27)
- If the connected equipment has an aspect adjustment function, set the aspect ratio to "16:9".
- These HDMI connectors are "type A".
- These HDMI connectors are compatible with HDCP (High-Bandwidth Digital Content Protection) copyright protection.
- An equipment having no digital output terminal may be connected to the input terminal of either "COMPONENT", "S-VIDEO", or "VIDEO" to receive analogue signals.
- This TV incorporates HDMI™ technology.

(*1): The HDMI logo is displayed on HDMI-compliant equipment.

(*2): Enquire at your local digital equipment retailer shop.

(*3): Audio Return Channel (ARC) is a function to be able to send digital sound signals via an HDMI cable.

PC connection

A PC may be connected to this TV so that the PC screen is displayed and sound is heard from the TV.

- PC signals that can be inputted: Horizontal scanning frequency 31 to 69 kHz; vertical scanning frequency 59 to 86 Hz (more than 1,024 signal lines could result in incorrect display of the image).
- A PC adapter is not necessary for the DOS/V-compliant D-sub 15-pin connector.

Note

- Some PC models cannot be connected to this TV.
- When using PC, set the colour display quality of PC to the highest position.
- For details of the applicable PC signals ➔ "Input signal that can be displayed" (p. 64)
- Max. display resolution

Aspect	4:3	1,024 × 768 pixels
	16:9	1,366 × 768 pixels

- D-sub 15-pin connector signal

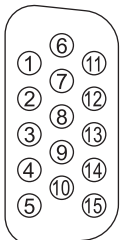

Pin No.	Signal Name	Pin No.	Signal Name	Pin No.	Signal Name
①	R	⑥	GND (Ground)	⑪	NC (not connected)
②	G	⑦	GND (Ground)	⑫	NC (not connected)
③	B	⑧	GND (Ground)	⑬	HD (HSYNC)
④	NC (not connected)	⑨	NC (not connected)	⑭	VD (VSYNC)
⑤	GND (Ground)	⑩	GND (Ground)	⑮	NC (not connected)

Technical Information

Input signal that can be displayed

COMPONENT (Y, P_B, P_R), HDMI

* Mark: Applicable input signal

Signal name	COMPONENT	HDMI
525 (480) / 60i	*	*
525 (480) / 60p	*	*
625 (576) / 50i	*	*
625 (576) / 50p	*	*
750 (720) / 60p	*	*
750 (720) / 50p	*	*
1,125 (1,080) / 60i	*	*
1,125 (1,080) / 50i	*	*
1,125 (1,080) / 60p		*
1,125 (1,080) / 50p		*
1,125 (1,080) / 24p		*

PC (from D-sub 15P)

Applicable input signal for PC is basically compatible to VESA standard timing.

Signal name	Horizontal frequency (kHz)	Vertical frequency (Hz)
640 × 400 @70 Hz	31.47	70.07
640 × 480 @60 Hz	31.47	59.94
640 × 480 @75 Hz	37.50	75.00
800 × 600 @60 Hz	37.88	60.32
800 × 600 @75 Hz	46.88	75.00
800 × 600 @85 Hz	53.67	85.06
852 × 480 @60 Hz	31.44	59.89
1,024 × 768 @60 Hz	48.36	60.00
1,024 × 768 @70 Hz	56.48	70.07
1,024 × 768 @75 Hz	60.02	75.03
1,024 × 768 @85 Hz	68.68	85.00
1,280 × 768 @60 Hz	47.70	60.00
1,280 × 1,024 @60 Hz	63.98	60.02
1,366 × 768 @60 Hz	48.39	60.04
Macintosh13" (640 × 480)	35.00	66.67
Macintosh16" (832 × 624)	49.73	74.55
Macintosh21" (1,152 × 870)	68.68	75.06

PC (from HDMI terminal)

Applicable input signal for PC is basically compatible to HDMI standard timing.

Signal name	Horizontal frequency (kHz)	Vertical frequency (Hz)
640 × 480 @60 Hz	31.47	60.00
750 (720) / 60p	45.00	60.00
1,125 (1,080) / 60p	67.50	60.00

Note

- Signals other than above may not be displayed properly.
- The above signals are reformatted for optimal viewing on your display.
- PC signal is magnified or compressed for display, so that it may not be possible to show fine detail with sufficient clarity.

FAQs

Before requesting service or assistance, please follow these simple guides to resolve the problem. If the problem still persists, please contact your local Panasonic dealer for assistance.

Block noise, frozen or disappearing image occurs in DVB mode / White spots or shadow image (ghosting) occurs in Analogue mode / Some channels cannot be tuned

- Check the position, direction and connection of the aerial.
- Check "Signal Condition" (p. 34). If "Signal Quality" is displayed in red, the DVB signal is weak.
- Weather conditions will affect signal reception (heavy rain, snow, etc.), in particular in poor reception areas. Even during good weather, the high pressure can cause poor reception of some channels.
- Due to the digital reception technologies involved, quality of the digital signals may be relatively low in some cases, despite good reception of analogue channels.
- Turn the TV off with the Mains power On / Off switch, and then on again.
- If problem persists, consult your local dealer or service provider for the availability of services.

Neither image nor sound is produced

- Is the TV in AV mode?
- Check the correct AV input mode is selected.
- Check the mains lead is plugged into the socket outlet.
- Has the TV been turned On?
- Check the Picture Menu (p. 26) and volume.
- Check all required cables and connections are firmly in place.

Auto aspect

- Auto aspect is designed to provide you with the best ratio to fill the screen. (p. 60)
- Press the ASPECT button if you would like to change the aspect ratio manually (p. 16).

S-Video / black and white picture

- Check that the output of the external equipment matches the input of the TV. If the output of the external equipment is set to S-Video, the TV must also be set to S-Video (p. 22).



No programmes shown on TV Guide

- Check the digital transmitter.
- Adjust the direction of the aerial to another transmitter installed nearby.
- Check the analogue broadcast.
If the image quality is poor, check the aerial and consult your local dealer.

Input mode, i.e. EC/AV1 remains on the screen

- Press the **i** button to clear these.
Press again to redisplay.

Q-Link function does not work

- Confirm SCART cable and connection.
Also set "AV1 out" in the Setup Menu (p. 28).

"VIERA Link" function does not work and an error message appears

- Confirm the connection. (p. 50 and p. 51)
- Turn the connected equipment on and then switch the TV on. (p. 53)

Recording does not start immediately

- Check the settings of the recorder. For details, read the manual of the recorder.

There may be red spots, blue spots, green spots and black spots on the screen

- This is a characteristic of liquid crystal panels and is not a problem. The liquid crystal panel is built with very high precision technology giving you fine picture details. Occasionally, a few non-active pixels may appear on the screen as a fixed point of red, green, blue or black. Please note this does not affect the performance of your LCD.

FAQs

	Problem	Actions
Screen	Chaotic image, noisy	<ul style="list-style-type: none"> ● Set "P-NR" in the Picture Menu (to remove noise). (p. 26) ● Check nearby electrical products (car, motorcycle, fluorescent lamp).
	No image can be displayed	<ul style="list-style-type: none"> ● Is "Contrast", "Brightness" or "Colour" in the Picture Menu set to the minimum? (p. 26)
	Blurry or distorted image (no sound or low volume)	<ul style="list-style-type: none"> ● Reset channels. (p. 32 and p. 33)
	Unusual image is displayed	<ul style="list-style-type: none"> ● Turn the TV Off with Mains power On / Off switch, then turn it On again. ● If the problem persists, perform "Shipping Condition" (p. 43).
Sound	No sound is produced	<ul style="list-style-type: none"> ● Is "Sound mute" active? (p. 8) ● Is the volume set to the minimum?
	Sound level is low or sound is distorted	<ul style="list-style-type: none"> ● Sound signal reception may be deteriorated. ● Set "MPX" (p. 27) in the Sound Menu to "Mono". (Analogue only)
HDMI	Sound is unusual	<ul style="list-style-type: none"> ● Set the sound setting of the connected equipment to "2ch L.PCM". ● Check the "HDMI1 / 2 Input" setting in the Sound Menu. (p. 27) ● If digital sound connection has a problem, select analogue sound connection. (p. 63)
	Pictures from external equipment are unusual when the equipment is connected via HDMI	<ul style="list-style-type: none"> ● Check the HDMI cable is connected properly. (p. 58 and p. 59) ● Turn the TV and equipment Off, then turn them On again. ● Check an input signal from the equipment. (p. 64) ● Use an equipment compliant with EIA/CEA-861/861B.
Other	The TV does not switch On	<ul style="list-style-type: none"> ● Check the mains lead is plugged into the socket outlet.
	The TV goes into Standby mode	<ul style="list-style-type: none"> ● Auto power standby function is activated. (p. 5) ● The TV enters Standby mode about 30 mins. after analogue broadcasting ends.
	The remote control does not work or is intermittent	<ul style="list-style-type: none"> ● Are the batteries installed correctly? (p. 6) ● Has the TV been switched On? ● The batteries may be running low. Replace them. ● Point the remote control directly at the front of the TV (within about 7 m and a 30 degree angle of the front of the TV). ● Situate the TV away from sunshine or other sources of bright light not to shine on the TV's remote control signal receiver.
	Parts of the TV become hot	<ul style="list-style-type: none"> ● Even when the temperature of parts of the front, top and rear panels has risen, these temperature rises will not pose any problems in terms of performance or quality.
	The LCD panel moves slightly when it is pushed with a finger Clattered sound might be heard	<ul style="list-style-type: none"> ● There is some flexibility around the panel to prevent damage to the panel. ● The panel might move slightly when it is pushed with a finger, and clattered sound might be heard. This is not a malfunction.
	An error message appears	<ul style="list-style-type: none"> ● Follow the message's instructions. ● If the problem persists, contact your local Panasonic dealer or the authorized Service Centre.

Specifications

		TH-32LRG20E		
Power Source		AC 220-240 V, 50 Hz		
Rated Power Consumption		93 W		
Standby Power Consumption		0.3 W 13 W (With monitor out recording)		
Display panel	Aspect Ratio	16:9		
	Visible screen size	80 cm (diagonal) 697 mm (W) × 392 mm (H)		
	Number of pixels	1,049,088 (1,366 (W) × 768 (H))		
Sound	Speaker	160 mm × 42 mm × 2 pcs, 8 Ω		
	Audio Output	10 W (5 W + 5 W) 10% THD		
	Headphones	M3 (3.5 mm) stereo mini Jack × 1		
PC signals		VGA, SVGA, XGA SXGA (compressed) Horizontal scanning frequency 31 - 69 kHz Vertical scanning frequency 59 - 86 Hz		
Receiving Systems / Band name		<p>PAL B, G, H, I, SECAM B, G, SECAM L, L' VHF E2 - E12 VHF H1 - H2 (ITALY) VHF A - H (ITALY) UHF E21 - E69 CATV (S01 - S05) CATV S1 - S10 (M1 - M10) CATV S11 - S20 (U1 - U10) CATV S21 - S41 (Hyperband)</p> <p>PAL D, K, SECAM D, K VHF R1 - R2 VHF R3 - R5 VHF R6 - R12 UHF E21 - E69</p> <p>PAL 525/60 Playback of NTSC tape from some PAL Video recorders (VCR) M.NTSC Playback from M.NTSC Video recorders (VCR) NTSC (AV input only) Playback from NTSC Video recorders (VCR) DVB-T Digital terrestrial services (MPEG2 and MPEG4-AVC(H.264)) DVB-C Digital cable services (MPEG2 and MPEG4-AVC(H.264)) Countries that DVB-C is available: Germany, Switzerland, Denmark, Sweden, Norway, Finland, Netherlands</p> <p>● Check the latest information on the available services at the following website. (English only) http://panasonic.jp/support/global/cs/</p>		
Aerial input		VHF / UHF		
Operating Conditions		Temperature : 0 °C - 35 °C Humidity : 20 % - 80 % RH (non-condensing)		
Connection Terminals	AV1 (SCART terminal)	21 Pin terminal (Audio/Video in, Audio/Video out, RGB in, S-Video in, Q-Link)		
	AV2	VIDEO	RCA PIN Type × 1 1.0 V[p-p] (75 Ω)	
		AUDIO L - R	RCA PIN Type × 2 0.5 V[rms]	
	COMPONENT	VIDEO	Y 1.0 V[p-p] (including synchronization) P_B, P_R ±0.35 V[p-p]	
		HDMI 1 / 2	TYPE A Connectors HDMI2 : HDMI (Version 1.4 with Audio Return Channel) ● This TV supports "HDAVI Control 5" function.	
	Others	PC	HIGH-DENSITY D-SUB 15PIN R,G,B/0.7 V[p-p] (75 Ω) HD, VD/TTL Level 2.0 - 5.0 V[p-p] (high impedance)	
		Card slot	SD Card slot × 1 Common Interface slot (complies with CI+) × 1	
		SERIAL CTRL	M3 (3.5 mm) mini Jack × 1, External control, RS-232C compatible	
		IR - OUT	M3 (3.5 mm) mini Jack × 1	
	Output	AUDIO L - R	RCA PIN Type × 2 0.5 V[rms] (high impedance)	
DIGITAL AUDIO OUT		PCM / Dolby Digital / DTS, Fiber optic		
Dimensions (W × H × D)		798 mm × 551 mm × 217 mm (With Pedestal) 798 mm × 511 mm × 93 mm (TV only)		
Mass		11.0 kg Net (With Pedestal) 9.5 kg Net (TV only)		

- Design and Specifications are subject to change without notice. Mass and Dimensions shown are approximate.
- This equipment complies with the EMC standards listed below.
EN55013, EN61000-3-2, EN61000-3-3, EN55020, EN55022, EN55024.

Information for Users on Collection and Disposal of Old Equipment and used Batteries



These symbols on the products, packaging, and/or accompanying documents mean that used electrical and electronic products and batteries should not be mixed with general household waste. For proper treatment, recovery and recycling of old products and used batteries, please take them to applicable collection points, in accordance with your national legislation and the Directives 2002/96/EC and 2006/66/EC.

By disposing of these products and batteries correctly, you will help to save valuable resources and prevent any potential negative effects on human health and the environment which could otherwise arise from inappropriate waste handling.

For more information about collection and recycling of old products and batteries, please contact your local municipality, your waste disposal service or the point of sale where you purchased the items.

Penalties may be applicable for incorrect disposal of this waste, in accordance with national legislation.



For business users in the European Union

If you wish to discard electrical and electronic equipment, please contact your dealer or supplier for further information.

[Information on Disposal in other Countries outside the European Union]

These symbols are only valid in the European Union. If you wish to discard these items, please contact your local authorities or dealer and ask for the correct method of disposal.



Note for the battery symbol (bottom two symbol examples):

This symbol might be used in combination with a chemical symbol. In this case it complies with the requirement set by the Directive for the chemical involved.

Cd

Licence

Even if no special notation has been made of company or product trademarks, these trademarks have been fully respected.

- DVB and the DVB logos are trademarks of the DVB Project.
- VGA is a trademark of International Business Machines Corporation.
- Macintosh is a registered trademark of Apple Inc., USA.
- S-VGA is a registered trademark of the Video Electronics Standard Association.
- SDXC Logo is a trademark of SD-3C, LLC.
- HDMI, the HDMI Logo, and High-Definition Multimedia Interface are trademarks or registered trademarks of HDMI Licensing LLC in the United States and other countries.
- HDAVI Control™ is a trademark of Panasonic Corporation.
- "AVCHD" and the "AVCHD" logo are trademarks of Panasonic Corporation and Sony Corporation.
- Manufactured under license from Dolby Laboratories.
Dolby and the double-D symbol are trademarks of Dolby Laboratories.
- Manufactured under license under U.S. Patent #: 5,451,942 & other U.S. and worldwide patents issued & pending.
DTS and the Symbol are registered trademarks and DTS Digital Out and the DTS logos are trademarks of DTS, Inc.
Product includes software. © DTS, Inc. All Rights Reserved.
- GUIDE Plus+ is (1) a registered trademark or trademark of, (2) manufactured under license from and (3) subject of various international patents and patent applications owned by, or licensed to, Gemstar-TV Guide International, Inc. and/or its related affiliates.



Declaration of Conformity (DoC)

Authorized Representative:

Panasonic Testing Centre

Panasonic Marketing Europe GmbH

Winsbergring 15, 22525 Hamburg, Germany

Customer's Record

The model number and serial number of this product may be found on its rear panel. You should note this serial number in the space provided below and retain this book, plus your purchase receipt, as a permanent record of your purchase to aid in identification in the event of theft or loss, and for Warranty Service purposes.

Model Number

Serial Number

Panasonic Corporation

Web Site : <http://www.panasonic.net>

© Panasonic Corporation 2010

Printed in Czech Republic