



8-CHANNEL VIDEO MIXER
V-8

Before using this unit, carefully read the sections entitled: "USING THE UNIT SAFELY" and "IMPORTANT NOTES" (p. 6-7; p. 8). These sections provide important information concerning the proper operation of the unit. Additionally, in order to feel assured that you have gained a good grasp of every feature provided by your new unit, Owner's Manual should be read in its entirety. The manual should be saved and kept on hand as a convenient reference.

Confirm the Contents of the Package

The V-8 includes the following items. Please take a moment to confirm that all of these items have been included with the V-8. If you find that any item is missing, contact the nearest authorized EDIROL/Roland distributor in your country.

V-8



AC adaptor/Power cord

* The shape of the power cord's plug varies depending on the country.



RCA-BNC adaptor plugs (four)



Screws for attaching the video fader (four spare screws)



Owner's manual (this document)



For the U.K.

IMPORTANT: THE WIRES IN THIS MAINS LEAD ARE COLOURED IN ACCORDANCE WITH THE FOLLOWING CODE.

BLUE: NEUTRAL
BROWN: LIVE

As the colours of the wires in the mains lead of this apparatus may not correspond with the coloured markings identifying the terminals in your plug, proceed as follows:
The wire which is coloured BLUE must be connected to the terminal which is marked with the letter N or coloured BLACK.
The wire which is coloured BROWN must be connected to the terminal which is marked with the letter L or coloured RED.
Under no circumstances must either of the above wires be connected to the earth terminal of a three pin plug.

Main Features

● Eight channels of video input

The V-8 provides video input connectors for eight video (composite) channels and four S-video channels. Of the input channels 1–8, S-video input is available only for channels 5–8.

* If S-video and video (composite) are both input to a channel 5–7, the input from the S-video connector will take priority and will be selected automatically. Likewise, if S-video and RGB signals from a computer are both input to channel 8, the S-video will take priority.

● Computer input jacks with built-in scan converters

A built-in scan converter supports RGB signals (VGA to UXGA) from a computer. The incoming RGB signal is converted to a video signal. By key-compositing a computer screen with a video image, you can use this as a titler.

* There are two computer input connectors. A switch on the operating panel allows one of the two to be selected.

● Two independent frame synchronizers

Even if an unstable video signal is input, the internal frame synchronizer can correct the synchronization signal. This allows you to use a variety of video without worrying about noise caused by unstable synchronization signals.

● Monitor out connectors for eight channels

An independent monitor out connector is provided for each video input channel 1–8.

* If both S-video and video (composite) signals are being input to channels 5–7, or if both an S-video signal and a computer output signal are being input to channel 8, the input from the S-video connector will take priority, and will be sent from monitor out. The input signal from the computer will also be sent from monitor out as a video signal.

● High-quality digital effects

Digitally processed effects are built in. You can apply a variety of high-quality effects including Picture In Picture, Mirror, Multi, Feedback, and Afterimage. In addition to the familiar Mix and Wipe transitions, new transitions such as FAM (Full Additive Mix), NAM (Non-Additive Mix), Slide, and Stretch are also provided.

● Simple and customizable operation

Switching between video sources and mixing them is easy. The T-bar type video fader can be attached in either a horizontal or vertical orientation according to your preference. Sliders are used for effect controllers, allowing you to operate the V-8 like a DJ mixer.

● Synchronize with music

By pressing the TAP button in time with the beat of the music, you can switch images or control effects in synchronization with the tempo (BPM).

● Control via MIDI

MIDI connectors (IN, OUT/THRU) are provided, allowing you to switch images or control effects by controlling the V-8 from an external MIDI device. You can also control an external device from the V-8.

In addition, the V-8 can be used in conjunction with V-LINK compatible audio/video equipment to easily create video output that is linked with the expressive elements of a performance.

Table of Contents



Introduction	
Confirm the Contents of the Package	2
Main Features	3
USING THE UNIT SAFELY	6
IMPORTANT NOTES	8
Video Signal Flow	9
Panel Descriptions.....	10
Connecting Peripheral Devices 14	
Basic Connections.....	14
Connecting the AC Adaptor	15
Examples of Using the V-8	16
Basic Operation 20	
Turning the Power On/Off	20
Checking the Input and Output.....	21
Outputting Images	21
Outputting a Preview Image	22
Menu Operations.....	23
Preparations for Viewing the Menu.....	23
Operating the Menu	24
About the Current Settings Display	26
Changing the Contents of the Settings Display	27
Storing the Operating Panel Settings ([MEMORY] Knob)	28
Settings Stored at the [MEMORY] Knob.....	28
Recalling a Memory.....	29
Copying the Contents of a Memory	29
Exchanging the Contents of Memories.....	30
Fading Out the Output Image.....	31
Fading Out the Bus A / Bus B Image.....	31
Fading Out the Final Output	32
Returning the Menu Settings to the Factory-Set State (Factory Reset).....	33
Returning All Settings to the Factory-Set State	33
Returning the Settings of a Specific Sub-Menu to the Factory-Set State	34
Switching Between Images 35	
Switching Between Two Images.....	35
Changing the Transition Assigned to Each TRANSITION Button	36
Combining Multiple Transition Effects (User Transition).....	38
Using the [TRANSFORMER] Buttons to Switch Images	40
Changing the Assignment of the [TRANSFORMER] Buttons.....	41
Using Effects 42	
About Effects.....	42
Combining Two Images.....	43
Using Picture In Picture (P in P) to Combine Images	43
Using Chroma-Key to Combine Images	45
Using Luminance-Key to Combine Images	46
Changing the Color of the Image.....	48
Inverting the Image to Form a Negative	48
Adding Color According to the Brightness or Darkness of the Image (Colorize)	49
Repeatedly Layering an Image onto Itself (Feedback)	50
Using Multi-Screen.....	51
Inverting the Image (Flip)	52
Assigning Different Effects to the EFFECTS Buttons	53

Editing the Input/Output Settings	54
Adjusting the Input Image	54
Adjusting the PC Input Image	54
Adjusting the Input Image for Bus A and B	56
Adjusting the Output Image	57
Outputting Color Bars	58
Switching Between NTSC and PAL	59
Switching Images in Synchronization with Music (BPM Sync)	60
Switching Images at a Specified BPM	60
Switching Images at the Tempo Specified by the [TAP] Button	61
Changing the Settings of the [BPM SYNC] Button	62
Using the V-8 with Other Equipment	63
Using MIDI to Control the V-8 from an External Device	63
About MIDI	63
Buttons and Knobs that Transmit or Receive MIDI Messages	64
MIDI Message Transmission Settings	66
MIDI Message Reception Settings	68
Saving V-8 Settings on an External MIDI Device (Bulk Dump)	69
Transmitting Menu Setting Data to an External MIDI Device	69
Restoring Data Saved on an External MIDI Device Back into the V-8	70
Sending the V-8's Settings to Another V-8	71
Controlling via V-LINK	72
What is V-LINK?	72
Controlling the RSS M-400 from the V-8 (V-LINK Master)	72
Controlling the V-8 from an External V-LINK Compatible Device (V-LINK Slave)	74
Using the V-8 in Conjunction with the PR Series (PR Control mode)	75
Adjusting the Video Fader	76
Installing the Video Fader in the Most Convenient Orientation	76
Calibrating the Video Fader	77
Specifying the Video Fader Operating Curve	78
Appendices	79
Troubleshooting	79
Menu List	81
MIDI Implementation	90
MIDI Implementation Chart	98
Transition Effect List	99
Effect List	105
Effects that Can Be Controlled by the [CONTROL] Fader	106
Effects that Cannot Be Used Simultaneously	107
Block Diagram	108
Main Specifications	109
Index	110
Information	113



USING THE UNIT SAFELY

INSTRUCTIONS FOR THE PREVENTION OF FIRE, ELECTRIC SHOCK, OR INJURY TO PERSONS

About ⚠ WARNING and ⚠ CAUTION Notices







 WARNING	Used for instructions intended to alert the user to the risk of death or severe injury should the unit be used improperly.
 CAUTION	Used for instructions intended to alert the user to the risk of injury or material damage should the unit be used improperly. * Material damage refers to damage or other adverse effects caused with respect to the home and all its furnishings, as well to domestic animals or pets.

About the Symbols







	The ⚠ symbol alerts the user to important instructions or warnings. The specific meaning of the symbol is determined by the design contained within the triangle. In the case of the symbol at left, it is used for general cautions, warnings, or alerts to danger.
	The ⚡ symbol alerts the user to items that must never be carried out (are forbidden). The specific thing that must not be done is indicated by the design contained within the circle. In the case of the symbol at left, it means that the unit must never be disassembled.
	The ⚡ symbol alerts the user to things that must be carried out. The specific thing that must be done is indicated by the design contained within the circle. In the case of the symbol at left, it means that the power-cord plug must be unplugged from the outlet.

ALWAYS OBSERVE THE FOLLOWING

WARNING

- Do not open or perform any internal modifications on the unit or its AC adaptor. (The only exception would be where this manual provides specific instructions; see p. 76.) 
- Do not attempt to repair the unit, or replace parts within it (except when this manual provides specific instructions directing you to do so). Refer all servicing to your retailer, the nearest EDIROL/Roland Service Center, or an authorized EDIROL/Roland distributor, as listed on the "Information" page. 
- Never use or store the unit in places that are:
 - Subject to temperature extremes (e.g., direct sunlight in an enclosed vehicle, near a heating duct, on top of heat-generating equipment); or are 
 - Damp (e.g., baths, washrooms, on wet floors); or are 
 - Humid; or are
 - Exposed to rain; or are
 - Dusty; or are
 - Subject to high levels of vibration.
- Make sure you always have the unit placed so it is level and sure to remain stable. Never place it on stands that could wobble, or on inclined surfaces. 
- Be sure to use only the AC adaptor supplied with the unit. Also, make sure the line voltage at the installation matches the input voltage specified on the AC adaptor's body. Other AC adaptors may use a different polarity, or be designed for a different voltage, so their use could result in damage, malfunction, or electric shock. 

WARNING

- Use only the attached power-supply cord. Also, the supplied power cord must not be used with any other device. 
- Do not excessively twist or bend the power cord, nor place heavy objects on it. Doing so can damage the cord, producing severed elements and short circuits. Damaged cords are fire and shock hazards! 
- Do not allow any objects (e.g., flammable material, coins, pins); or liquids of any kind (water, soft drinks, etc.) to penetrate the unit. 

- Immediately turn the power off, remove the AC adaptor from the outlet, and request servicing by your retailer, the nearest EDIROL/Roland Service Center, or an authorized EDIROL/Roland distributor, as listed on the "Information" page when:
 - The AC adaptor, the power-supply cord, or the plug has been damaged; or
 - If smoke or unusual odor occurs
 - Objects have fallen into, or liquid has been spilled onto the unit; or
 - The unit has been exposed to rain (or otherwise has become wet); or
 - The unit does not appear to operate normally or exhibits a marked change in performance.
- In households with small children, an adult should provide supervision until the child is capable of following all the rules essential for the safe operation of the unit. 

⚠ WARNING

- Protect the unit from strong impact. (Do not drop it!) 

- Do not force the unit's power-supply cord to share an outlet with an unreasonable number of other devices. Be especially careful when using extension cords—the total power used by all devices you have connected to the extension cord's outlet must never exceed the power rating (watts/amperes) for the extension cord. Excessive loads can cause the insulation on the cord to heat up and eventually melt through. 

- Before using the unit in a foreign country, consult with your retailer, the nearest EDIROL/Roland Service Center, or an authorized EDIROL/Roland distributor, as listed on the "Information" page. 

- Always turn the unit off and unplug the AC adaptor before attempting installation of the video fader (p. 76). 

⚠ CAUTION

- The unit and the AC adaptor should be located so their location or position does not interfere with their proper ventilation. 

- Always grasp only the plug on the AC adaptor cord when plugging into, or unplugging from, an outlet or this unit. 

- At regular intervals, you should unplug the AC adaptor and clean it by using a dry cloth to wipe all dust and other accumulations away from its prongs. Also, disconnect the power plug from the power outlet whenever the unit is to remain unused for an extended period of time. Any accumulation of dust between the power plug and the power outlet can result in poor insulation and lead to fire. 

- Try to prevent cords and cables from becoming entangled. Also, all cords and cables should be placed so they are out of the reach of children. 

- Never climb on top of, nor place heavy objects on the unit. 

- Never handle the AC adaptor or its plugs with wet hands when plugging into, or unplugging from, an outlet or this unit. 

- Before moving the unit, disconnect the AC adaptor and all cords coming from external devices. 

- Before cleaning the unit, turn off the power and unplug the AC adaptor from the outlet. 

- Whenever you suspect the possibility of lightning in your area, disconnect the AC adaptor from the outlet. 

- For installation of the video fader, remove only the specified screws (p. 76). 

- Keep any screws for the attaching the video fader and ground terminal you may remove and the included RCA-BNC adaptor plugs and screws for attaching the video fader in a safe place out of children's reach, so there is no chance of them being swallowed accidentally. 

IMPORTANT NOTES

Power Supply

- Do not connect this unit to same electrical outlet that is being used by an electrical appliance that is controlled by an inverter (such as a refrigerator, washing machine, microwave oven, or air conditioner), or that contains a motor. Depending on the way in which the electrical appliance is used, power supply noise may cause this unit to malfunction or may produce visible noise. If it is not practical to use a separate electrical outlet, connect a power supply noise filter between this unit and the electrical outlet.
- The AC adaptor will begin to generate heat after long hours of consecutive use. This is normal, and is not a cause for concern.
- Before connecting this unit to other devices, turn off the power to all units. This will help prevent malfunctions and/or damage to video monitors or other devices.

Placement

- This unit may interfere with radio and television reception. Do not use this unit in the vicinity of such receivers.
- Noise may be produced if wireless communications devices, such as cell phones, are operated in the vicinity of this unit. Such noise could occur when receiving or initiating a call, or while conversing. Should you experience such problems, you should relocate such wireless devices so they are at a greater distance from this unit, or switch them off.
- When moved from one location to another where the temperature and/or humidity is very different, water droplets (condensation) may form inside the unit. Damage or malfunction may result if you attempt to use the unit in this condition. Therefore, before using the unit, you must allow it to stand for several hours, until the condensation has completely evaporated.
- Depending on the material and temperature of the surface on which you place the unit, its rubber feet may discolor or mar the surface.
You can place a piece of felt or cloth under the rubber feet to prevent this from happening. If you do so, please make sure that the unit will not slip or move accidentally.

Maintenance

- For everyday cleaning wipe the unit with a soft, dry cloth or one that has been slightly dampened with water. To remove stubborn dirt, use a cloth impregnated with a mild, non-abrasive detergent. Afterwards, be sure to wipe the unit thoroughly with a soft, dry cloth.
- Never use benzene, thinners, alcohol or solvents of any kind, to avoid the possibility of discoloration and/or deformation.

Repairs and Data

- Please be aware that all data contained in the unit's memory may be lost when the unit is sent for repairs. Important data should always be backed up in another MIDI device (e.g., a sequencer), or written down on paper (when possible). During repairs, due care is taken to avoid the loss of data. However, in certain cases (such as when circuitry related to memory itself is out of order), we regret that it may not be possible to restore the data, and Roland assumes no liability concerning such loss of data.

Additional Precautions

- This unit allows you to switch images or turn video effects on/off at high speed. For some people, viewing such images can cause headache, nausea, or other discomfort. Do not use this unit to create video that might cause these types of health problems. Roland Corporation will accept no responsibility for any such health problems that may occur in yourself or in viewers.
- Please be aware that the contents stored at the [MEMORY] knob (p. 28) can be irretrievably lost as a result of a malfunction, or the improper operation of the unit. To protect yourself against the risk of losing important data, we recommend that you periodically save a backup copy of important data you have stored in the unit's memory in another MIDI device (e.g., a sequencer).
- Unfortunately, it may be impossible to restore the contents of data that was stored in another MIDI device (e.g., a sequencer) once it has been lost. Roland Corporation assumes no liability concerning such loss of data.
- Use a reasonable amount of care when using the unit's buttons, sliders, or other controls; and when using its jacks and connectors. Rough handling can lead to malfunctions.
- When connecting / disconnecting all cables, grasp the connector itself—never pull on the cable. This way you will avoid causing shorts, or damage to the cable's internal elements.
- When you need to transport the unit, package it in the box (including padding) that it came in, if possible. Otherwise, you will need to use equivalent packaging materials.

Copyright

- Recording, duplication, distribution, sale, lease, performance, or broadcast of copyrighted material (musical works, visual works, broadcasts, live performances, etc.) belonging to a third party in part or in whole without the permission of the copyright owner is forbidden by law.
- This product can be used to record or duplicate visual material without being limited by certain technological copy-protection measures. This is due to the fact that this product is intended to be used for the purpose of producing original video material, and is therefore designed so that material that does not infringe copyrights belonging to others (for example, your own original works) can be recorded or duplicated freely.
- Do not use this unit for purposes that could infringe on a copyright held by a third party. We assume no responsibility whatsoever with regard to any infringements of third-party copyrights arising through your use of this unit.

* Microsoft and Windows are registered trademarks of Microsoft Corporation.

* Apple and Macintosh are registered trademarks of Apple Inc.

Video Signal Flow

You can use the input selector to choose any two of the video signals coming into the eight input jacks. These two video signals are sent to **bus A** and **bus B** of the video mixer section.

The video signals sent to bus A and bus B are mixed in the video mixer section. The mixed signal then passes through the output fader and is sent from the output jack.

☞ For details on the structure of the mixer, refer to “Block Diagram” (p. 108).

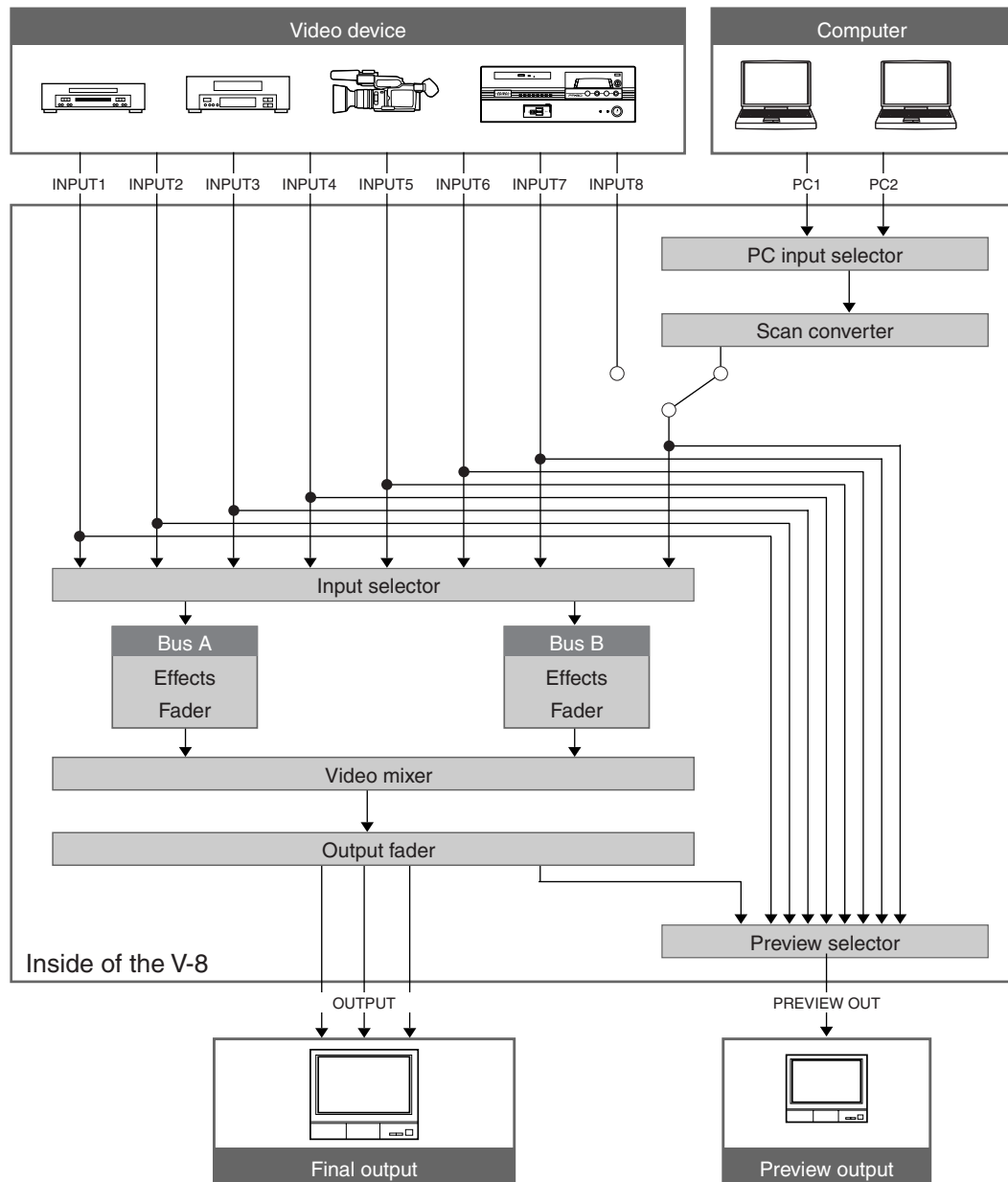

- * The preview output will also show the settings menu of the V-8 overlaid with the image (p. 23).
- * INPUTs 5–7 provide composite connectors and S-video connectors. If an image is being input to both connectors of the same channel, the input from the S-video connector will take priority.
- * INPUT 8 provides both an S-video connector and a PC connector. If an image is being input to both of these, the input from the S-video connector will take priority.

Panel Descriptions

Operating Panel

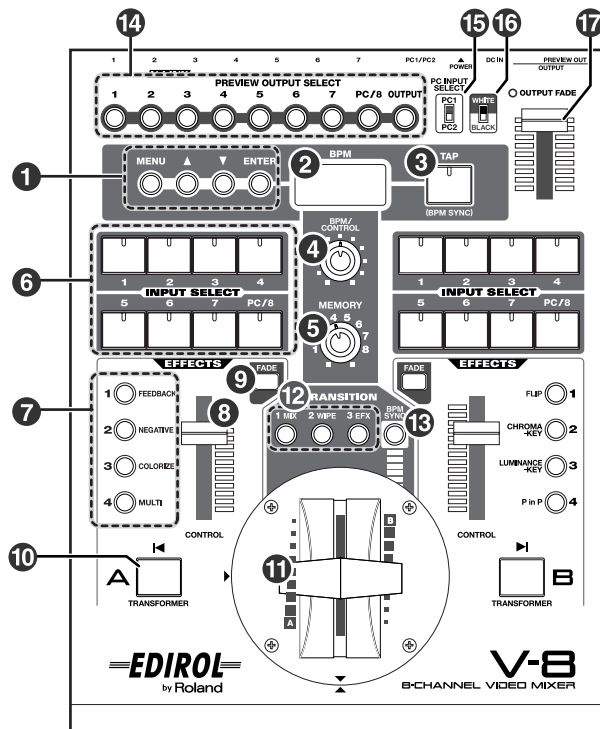

1 Menu Operation Buttons

These are used when working with the menu.

☞ “Operating the Menu” (p. 24)

● [MENU] Button

This button overlays the menu onto the television monitor connected to the PREVIEW OUT connector (p. 13).

If you’ve moved to a lower-level menu, this button will return you to the preceding menu (the next higher level).

If the menu is displayed, the [MENU] button will light.

● [▲][▼] Buttons

These buttons move the cursor that is displayed in the menu. Alternatively, they edit a value in the menu.

● [ENTER] Button

This button confirms the menu item you’ve selected, and takes you to the next menu (a lower level).

2 BPM Display

- This shows the current BPM (Beats Per Minute).

☞ “Switching Images at a Specified BPM” (p. 60)

- If you’ve chosen “003: Fam*” or “005: Nam*” as the transition effect selected by a TRANSITION button, this will blink to indicate the FAM/NAM cross point level.

☞ “Changing the cross point of the FAM/NAM” (p. 37)

3 [TAP] Button

You can specify the BPM by pressing the [TAP] button at the desired interval.

☞ “Switching Images at the Tempo Specified by the [TAP] Button” (p. 61)

4 [BPM/CONTROL] Knob

- Use this to edit the BPM value.

- If you’ve used the TRANSITION buttons (11) to select “003: Fam*” or “005: Nam*” as the transition effect, this will adjust the way in which the transition occurs.

☞ “About the FAM and NAM Transition Effects” (p. 37)

5 [MEMORY] Knob

This knob stores up to seven settings (memory numbers 2–8) for the operating panel (i.e., the buttons and faders). The factory preset settings are assigned to memory number 1.

The stored settings will be called up when you turn the [MEMORY] knob to the desired memory number.

☞ “Storing the Operating Panel Settings ([MEMORY] Knob)” (p. 28)

6 Bus A INPUT SELECT Buttons

Use these buttons to select the image that will be input to bus A of the video mixer.

The indicator of the selected INPUT SELECT button will light.

☞ “Switching Between Two Images” (p. 35)



- * For channels 5–8, input from the S-video connector will take priority.
- * Use the [PC INPUT SELECT] button to choose the input from the PC1/PC2 connectors.

7 Bus A EFFECTS Buttons

These buttons turn effects on/off for the bus A image of the video mixer. If an effect is on, the button will be lit or blinking.

You can use up to four effects simultaneously.

☞ “Using Effects” (p. 42)

* The EFFECTS button will blink if you've selected an effect that can be controlled by the [CONTROL] fader (8). For details, refer to “Effects that can be controlled by the [CONTROL] faders” (p. 42).

* Depending on the type of effect, there are some combinations that cannot be used simultaneously. For details, refer to “Effects that Cannot Be Used Simultaneously” (p. 107).

The settings listed below are the settings for memory number 1 of the [MEMORY] knob. By selecting memory numbers 2–8 you can assign other effects to the EFFECTS buttons.

[1 (FEEDBACK)] button	Feedback (022: FEEDBACK*)
[2 (NEGATIVE)] button	Negative (033: NEGATIVE*)
[3 (COLORIZE)] button	Colorize (042: COLORIZE*)
[4 (MULTI)] button	Multi (126: MULTI-HV*)

☞ “Assigning Different Effects to the EFFECTS Buttons” (p. 53)

8 Bus A [CONTROL] Fader

● You can use this fader to control the settings of an effect assigned to the blinking EFFECTS button.

☞ “Effects that can be controlled by the [CONTROL] faders” (p. 42)

● If the [FADE] button (9) is blinking, this will fade in/out the bus A image.

The fade color is fixed at black.

☞ “Fading Out the Bus A / Bus B Image” (p. 31)

9 Bus A [FADE] Button

This button lets you use the bus A [CONTROL] fader to fade the bus A image.

While the [FADE] button is blinking, operating the [CONTROL] fader will fade in/out the bus A image.

[FADE] button	Fade function
Blinking	On
Lit	On
Unlit	Off

☞ “Fading Out the Bus A / Bus B Image” (p. 31)

10 Bus A [TRANSFORMER] Button

This button switches between the bus A and bus B images without using the video fader.

☞ “Using the [TRANSFORMER] Buttons to Switch Images” (p. 40)

11 Video Fader

This is a T-bar type video fader. It switches between the bus A and bus B images.

☞ “Switching Between Two Images” (p. 35)

The video fader can be installed in the V-8 in either a vertical or a horizontal orientation, and you are free to change this to suit your preference.

☞ “Installing the Video Fader in the Most Convenient Orientation” (p. 76)

12 TRANSITION Buttons

Here you can select the way in which you will transition between the bus A and bus B images. The button you've selected will light.

The settings listed below are for memory number 1 of the [MEMORY] knob. By selecting memory numbers 2–8 you can assign different transition effects to each TRANSITION button.

[1 MIX] button	Dissolve (001: Mix01)
[2 WIPE] button	Wipe (008: Wipe03)
[3 EFX] button	Soft edge wipe (192: SWipe88)

☞ “Switching Between Two Images” (p. 35)

13 [BPM SYNC] Button

This lets you automatically switch between images or turn effects on/off in synchronization with the BPM (BMP Sync).

☞ “Switching Images in Synchronization with Music (BPM Sync)” (p. 60)

14 PREVIEW OUT SELECT Buttons

These buttons select the preview image that will be output from the PREVIEW OUT connector (p. 13).

● [1]–[PC/8] Buttons

The image being input to the INPUT 1–8/PC1/PC2 connector will be sent from the preview output. The channel number or menu (p. 23) will be shown overlaid on the preview output.

* The input from the S-video connector will take priority for channels 5–8.

* Use the [PC INPUT SELECT] switch to choose between the PC1/PC2 connector inputs.

* The menu will appear if you press the [MENU] button.

● [OUTPUT] Button

The final output image will be sent from the preview output. Information about the settings (p. 26) or the menu (p. 23) will be shown overlaid on the preview output.

* The menu will appear if you press the [MENU] button.

15 [PC INPUT SELECT] Switch

This switches between the PC1 input and PC2 input.

16 [WHITE/BLACK] Switch

This selects either “white” or “black” as the fade color applied when you operate the [OUTPUT FADE] fader.

WHITE	Fade to white
BLACK	Fade to black

17 [OUTPUT FADE] Fader

Lowering the [OUTPUT FADE] fader will fade out the image (final output) being sent from the OUTPUT connector.

Raising the [OUTPUT FADE] fader will fade in the image.

☞ “Fading Out the Final Output” (p. 32)

● OUTPUT FADE indicator

The indicator located above the [OUTPUT FADE] fader indicates the fade status.

Blinking	Now fading in/out
Lit	Normal output

Operating Panel (continued)

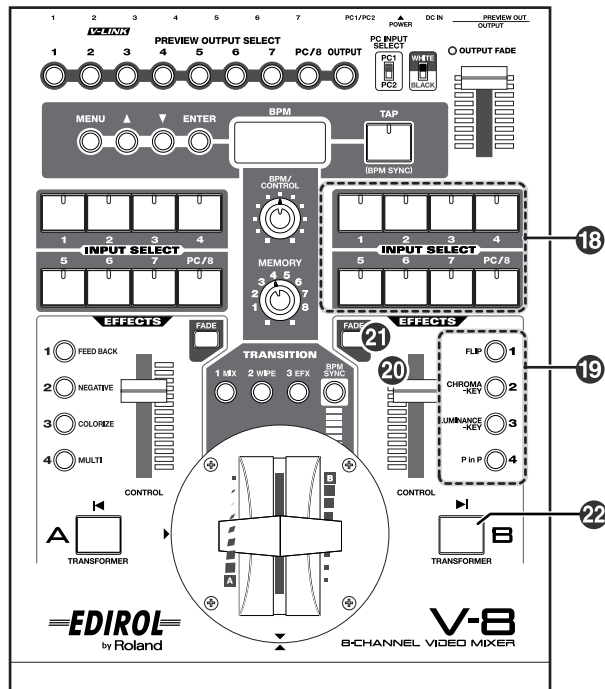

18 Bus B INPUT SELECT Buttons

Use these buttons to select the image that will be input to bus B of the video mixer.

The indicator of the selected INPUT SELECT button will light.



☞ “Switching Between Two Images” (p. 35)

- * For channels 5–8, input from the S-video connector will take priority.
- * Use the [PC INPUT SELECT] button to choose the input from the PC1/PC2 connectors.

19 Bus B EFFECTS Buttons

These buttons turn effects on/off for the bus B image of the video mixer. If an effect is on, the button will be lit or blinking.

You can use up to four effects simultaneously.

☞ “Using Effects” (p. 42)

- * The EFFECTS button will blink if you’ve selected an effect that can be controlled by the [CONTROL] fader (20). For details, refer to “Effects that can be controlled by the [CONTROL] faders” (p. 42).
- * Depending on the type of effect, there are some combinations that cannot be used simultaneously. For details, refer to “Effects that Cannot Be Used Simultaneously” (p. 107).

The settings listed below are the settings for memory number 1 of the [MEMORY] knob. By selecting memory numbers 2–8 you can assign other effects to the EFFECTS buttons.

[1 (FLIP)] button	Flip (102: FLIP*)
[2 (CHROMA KEY)] button	Chroma key (098: CHROMAKEY*)
[3 (LUMINANCE KEY)] button	Luminance key (096:B-LUMIKEY*)
[4 (P in P)] button	Picture in picture (150: PinP*)

☞ “Assigning Different Effects to the EFFECTS Buttons” (p. 53)

20 Bus B [CONTROL] Fader

- You can use this fader to control the settings of an effect assigned to the blinking EFFECTS button.

☞ “Effects that can be controlled by the [CONTROL] faders” (p. 42)

- If the [FADE] button (21) is blinking, this will fade in/out the bus B image.

The fade color is fixed at black.

☞ “Fading Out the Bus A / Bus B Image” (p. 31)

21 Bus B [FADE] Button

This button lets you use the bus B [CONTROL] fader to fade the bus B image.

While the [FADE] button is blinking, operating the [CONTROL] fader will fade in/out the bus B image.

[FADE] button	Fade function
Blinking	On
Lit	On
Unlit	Off

☞ “Fading Out the Bus A / Bus B Image” (p. 31)

22 Bus B [TRANSFORMER] Button

This button switches between the bus A and bus B images without using the video fader.

☞ “Using the [TRANSFORMER] Buttons to Switch Images” (p. 40)

Rear Panel

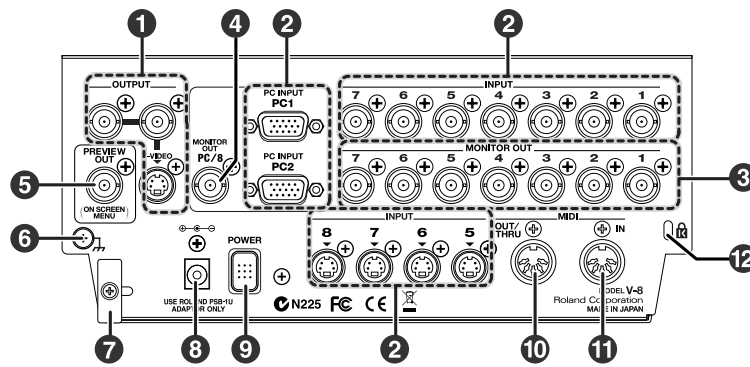
**1 OUTPUT Connectors**

- **Composite output connectors**

These are BNC connectors that output the final output image as a composite video signal.

* If the connection cable you're using has an RCA phono type plug, use the included (or commercially available) RCA-BNC adaptors.

- **S-video output connector**

This outputs the final output image as an S-video signal.

2 INPUT Connectors (channels 1–8)

* For channels 5–8, input from the S-video connector will take priority.

- **Composite input connectors (channels 1–7)**

These are D-sub 15-pin connectors that input a composite video signal. Here you can connect video equipment that has composite video output connectors.

* If the connection cable you're using has an RCA phono type plug, use the included (or commercially available) RCA-BNC adaptors.

- **S-video input connectors (channels 5–8)**

These connectors can accept S-video signals.

Here you can connect video equipment that has an S-video output connector.

- **PC1/PC2 input connectors (channel 8)**

These are D-sub 15-pin connectors for inputting RGB signals. Use the [PC INPUT SELECT] switch (p. 11) to choose between the PC1 input or PC2 input.

☞ "Adjusting the PC Input Image" (p. 54)

3 MONITOR OUT Connectors (channels 1–7)

These are BNC connectors that output the composite video signal from the images being input to the composite input connectors or S-video input connectors.

You can connect these to television monitors that have composite video inputs, and use them to view the input image for each channel.

* The input from the S-video connector will take priority for channels 5–7.

* If the connection cable you're using has an RCA phono type plug, use the included (or commercially available) RCA-BNC adaptors.

4 MONITOR OUT PC/8 Connector (channel 8)

This is a BNC connector that outputs a composite video signal of the image that is being input to the channel 8 S-video connector or to the PC1/PC2 input connector.

Here you can connect a television monitor that has a composite video input connector, and use it to view the input image.

* The input from the S-video connector will take priority for channel 8.

* If the connection cable you're using has an RCA phono type plug, use the included (or commercially available) RCA-BNC adaptors.

5 PREVIEW OUT Connector

This is a BNC connector that outputs the composite signal for the image selected by the PREVIEW OUT SELECT buttons (p. 11). If you are previewing an input image from the INPUT 1–8/PC1/PC2 connectors, the channel number or menu (p. 23) will be overlaid on the image.

If you are previewing the final output image, the menu (p. 23) or information about the settings (p. 26) will be overlaid on the image.

* If the connection cable you're using has an RCA phono type plug, use the included (or commercially available) RCA-BNC adaptors.

* The menu is shown when you press the [MENU] button (p. 10).

6 Ground Terminal

Use this to connect an external earth or ground.

☞ "About the ground terminal" (p. 15)

7 Cord Hook

Fasten the cord of the included AC adaptor to this hook so that the cord will not be disconnected accidentally.

☞ "Connecting the AC Adaptor" (p. 15)

8 AC Adaptor Connector

Connect the included AC adaptor here.

☞ "Connecting the AC Adaptor" (p. 15)

9 [POWER] Switch

This turns the power on/off.

☞ "Turning the Power On/Off" (p. 20)

10 MIDI OUT/THRU Connector

You can switch the function of this connector between MIDI OUT and MIDI THRU.

☞ "MIDI OUT/THRU connector setting" (p. 66)

- **MIDI OUT**

This connector will transmit MIDI messages to an external device.

- **MIDI THRU**

This connector will retransmit (without change) any MIDI messages arriving at the MIDI IN connector.

11 MIDI IN Connector

This connector receives MIDI messages from an external MIDI device.

12 Security Slot ()

You can attach a commercially available security lock here. For details, refer to the following website:

<http://www.kensington.com/>

Connecting Peripheral Devices

Basic Connections

- * To prevent malfunction and/or damage to video monitors or other devices, always turn off the power on all devices before making any connections.
- * Be sure to use cables and adapter plugs with the proper connectors matching those of the other devices you are using.

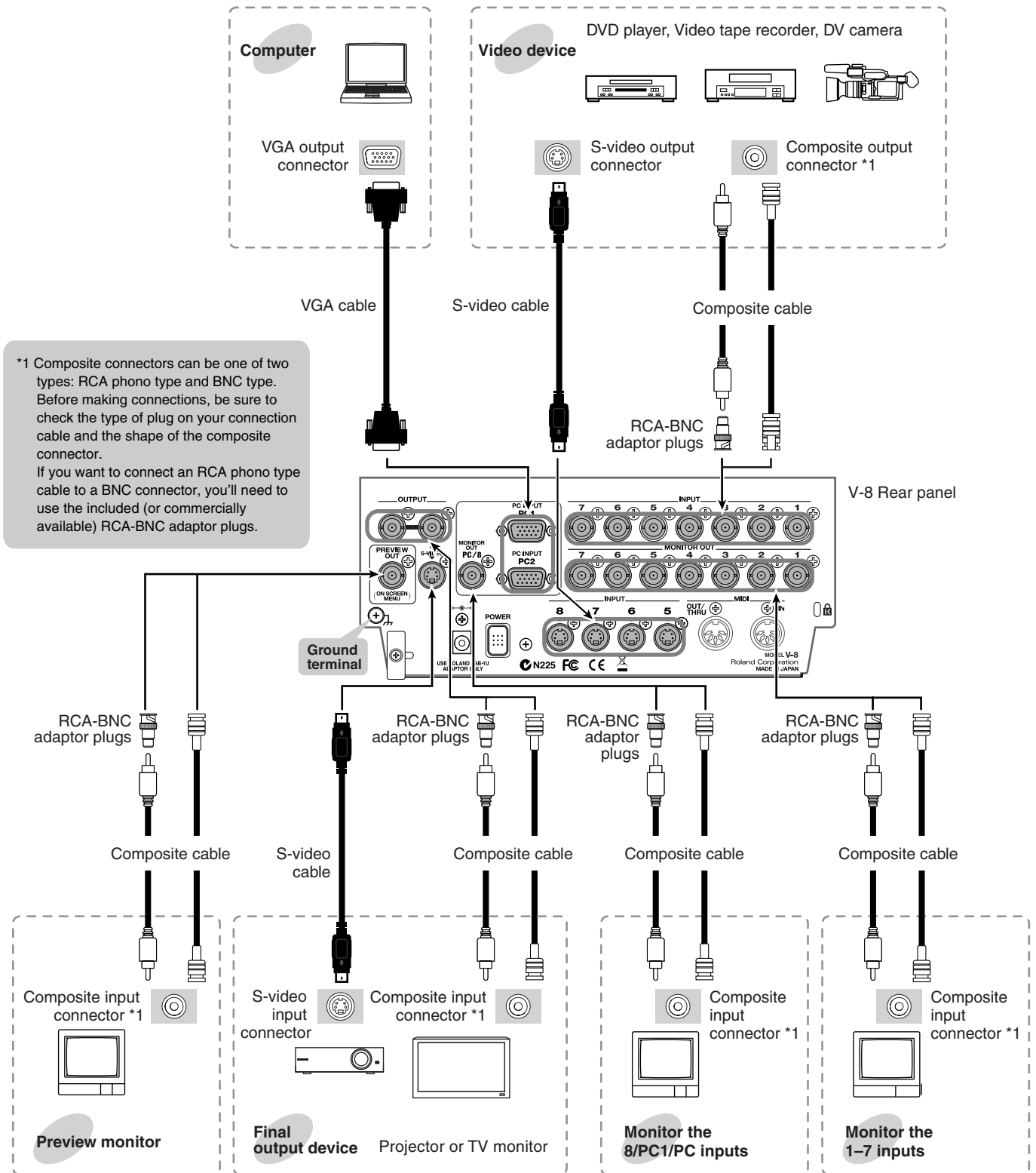

- **About the composite connectors and MONITOR OUT connectors**

The V-8's composite inputs and outputs use BNC connectors. If your connection cables have RCA phono plugs, you'll need to use the included (or commercially available) RCA-BNC adaptor plugs.

- **About cable routing**

Using an S-video cable will provide a higher-quality image. However, if the cable routing is very long, noise may appear in the image. If this occurs, use a composite cable.

- **About the inputs**

The S-video connector input will take priority for input channels 5–8.

- **About the final output**

The same image is sent from all of the OUTPUT connectors (composite connectors and S-video connector).

- **About the ground terminal**

Depending on the circumstances of a particular setup, you may experience a discomforting sensation, or perceive that the surface feels gritty to the touch when you touch this device. This is due to an infinitesimal electrical charge, which is absolutely harmless. However, if you are concerned about this, connect the ground terminal with an external ground. When the unit is grounded, a slight hum may occur, depending on the particulars of your installation. If you are unsure of the connection method, contact the nearest EDIROL/Roland Service Center, or an authorized EDIROL/Roland distributor, as listed on the "Information" page.

Unsuitable places for connection

- Water pipes (may result in shock or electrocution)
- Gas pipes (may result in fire or explosion)
- Telephone-line ground or lightning rod (may be dangerous in the event of lightning)

Connecting the AC Adaptor

- * Place the AC adaptor so the side with the indicator (see illustration) faces upwards and the side with textual information faces downwards. The indicator will light when you plug the AC adaptor into an AC outlet.

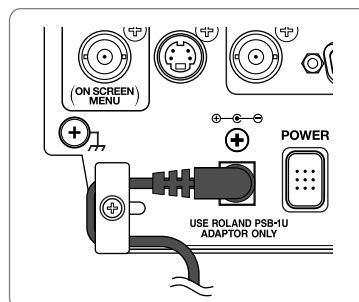
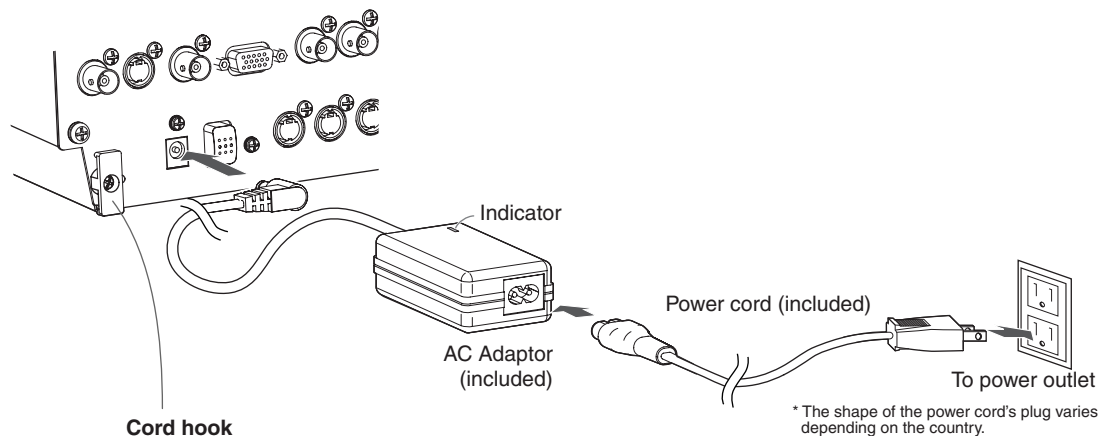

To prevent the inadvertent disruption of power to your unit (should the plug be pulled out accidentally), and to avoid applying undue stress to the AC adaptor connector, anchor the power cord using the cord hook, as shown in the illustration.

Examples of Using the V-8

Events

In events that involve various types of exhibition or video performance, you can use the V-8 to switch between multiple live video sources and the video from a DVD or computer.

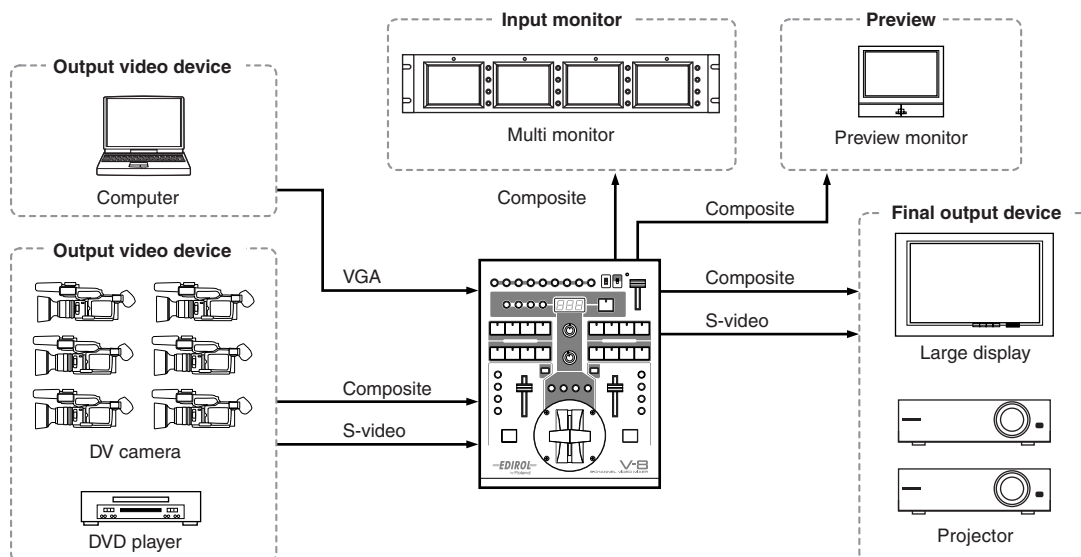

● Advantages of using the V-8

- You can mix two video images (e.g., two live images, live image + DVD/computer image)
- You can use the Picture In Picture effect to display two images simultaneously (p. 43).
- Since a scan converter is built in, still images and the like from a computer can be input directly.

Concerts or VJ Performances

Images can be projected on a large screen located at the back of the stage to create a video performance that's synchronized to the music. You can mix images from a PR-50/80 or computer (VJ software) with multiple live images.

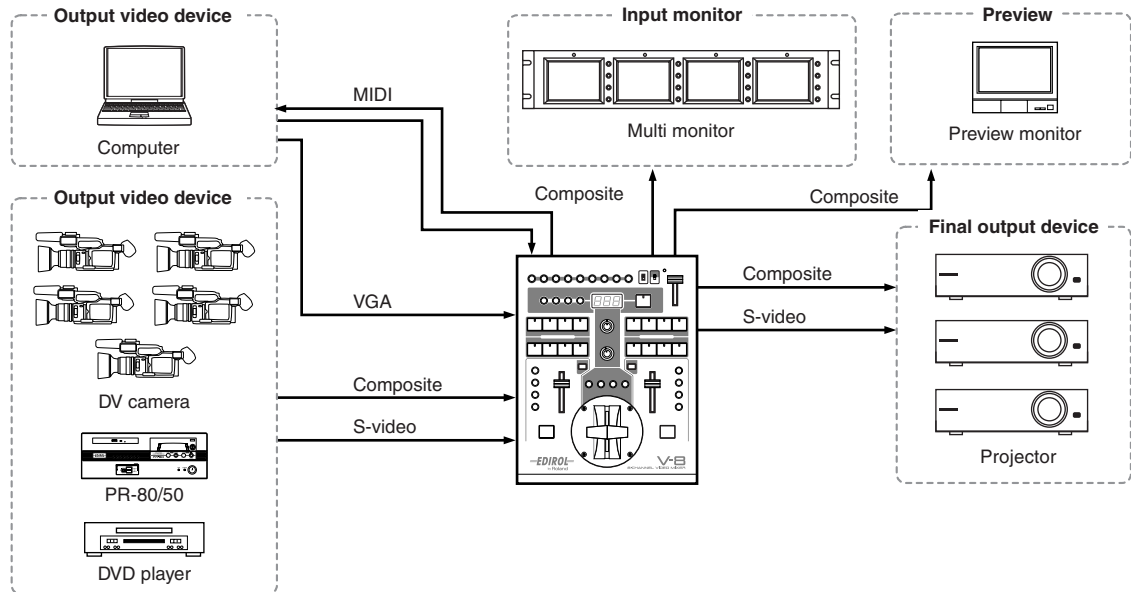

● Advantages of using the V-8

- You can use the BPM Sync function to switch images in time with the music (p. 60).
- You can combine multiple transition effects to create an original transition pattern (User Transition; p. 38).
- You can use numerous effects such as Feedback, After-image, and Silhouette.
- Since a scan converter is built in, video from a computer (VJ software) can be input directly. You can also use the V-8's Zoom function to input just a portion of the image.
- You can use the V-8's [CONTROL] faders to dynamically apply an effect or fade to the input signal.
- You can set the V-8 to Local Off, and use it to control the VJ software on your computer without affecting the output image (Panel Mode; p. 67).

Presentations

You can switch between photos or DVD output, or superimpose images or text from your computer.

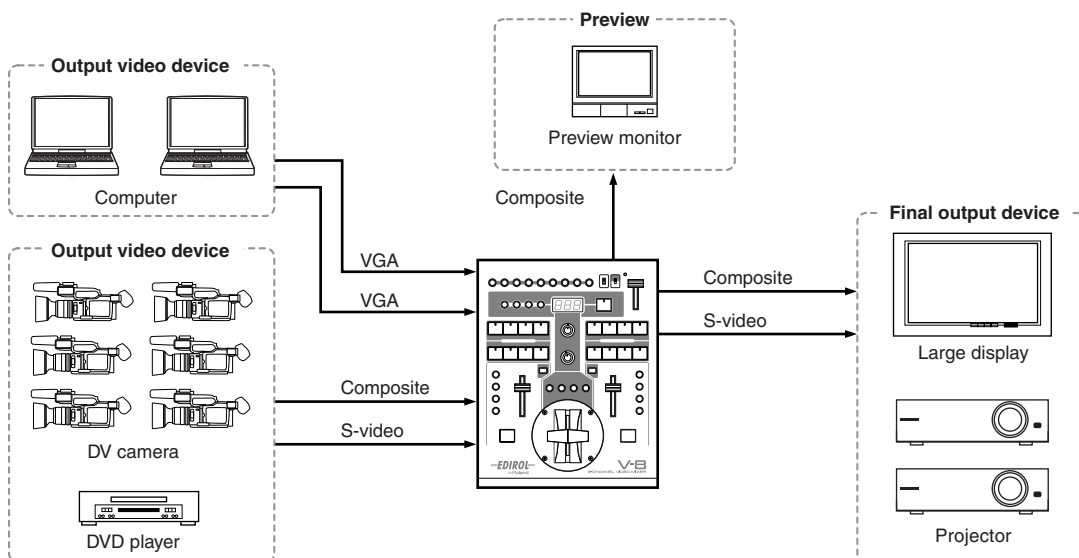

● Advantages of using the V-8

- You can use the Picture In Picture effect to show two images simultaneously (p. 43).
- You can use Luminance keying to superimpose text or graphics on an image (p. 46).
- Since a scan converter is built in, you can directly input presentation material from your computer.
- Since there are two PC inputs, you can connect and use two computers.

Background Video for a Musical Performance (Using V-LINK)

You can control background video (BGV) simultaneously while playing an instrument.

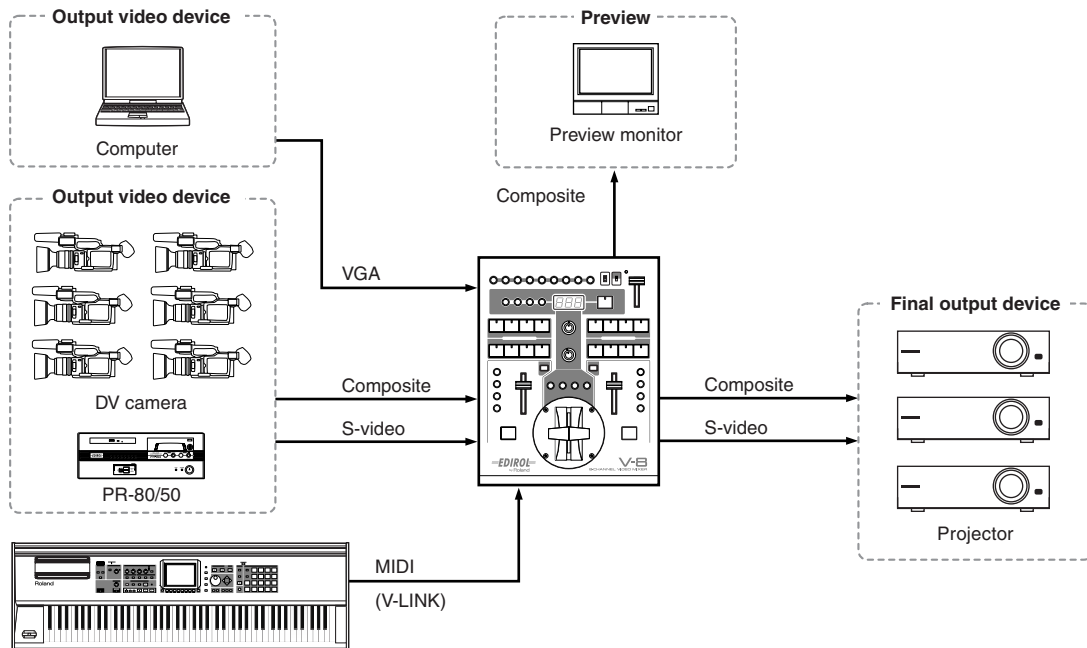

Advantages of using the V-8

- By using the V-8 in conjunction with the PR-50/80 you can control live video and images from the PR-50/80 using just one device.
- You can switch effects on/off from your instrument.
- If you're using V-LINK compatible devices, MIDI settings can be dramatically simplified.

Using the V-8 with the RSS M-400 (Using V-LINK)

You can control the M-400 in synchronization with the switching of images.

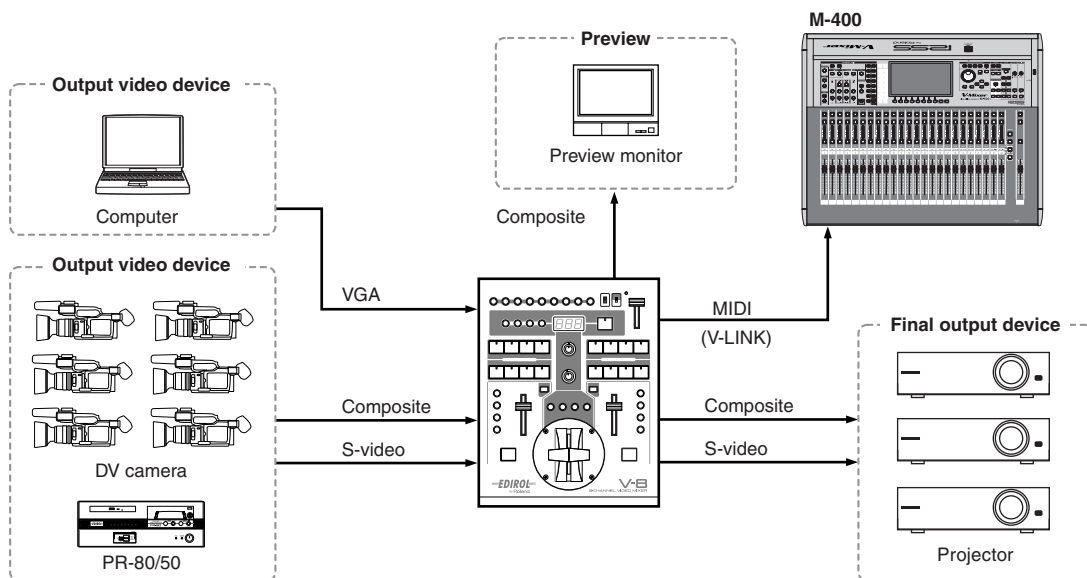

Advantages of using the V-8

- Using V-LINK lets you synchronize the V-8's video fader operations with the M-400's audio input levels.

Basic Operation

Turning the Power On/Off

Turning the Power On

- 1 Make sure that the V-8 is correctly connected to your other equipment.
- 2 Press the [POWER] switch located on the V-8's rear panel to turn it on.

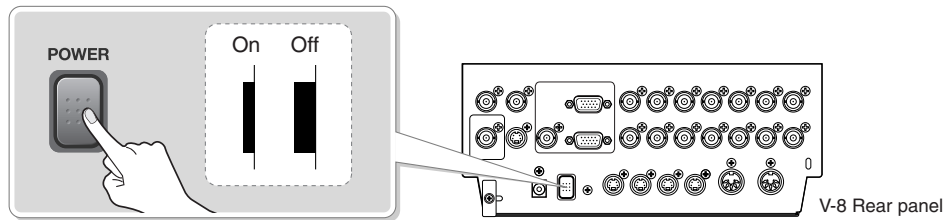

Turning the Power Off

NOTE

If you've used a menu operation (p. 24) to modify any parameters, close the menu before you turn off the power. If you turn off the power before closing the menu, the changes you made will be discarded.

- 1 Press the [POWER] switch located on the V-8's rear panel to turn it off.

Checking the Input and Output

Outputting Images

Here's how to verify that the image is being correctly output to the TV monitor or projector connected to the OUTPUT connector.

- 1 Power up your connected equipment and the V-8.**
- 2 Play back your video device.**
Input the image from the video device (camera, VTR, DVD player, etc.) or computer.
- 3 Raise the [OUTPUT FADE] fader.**

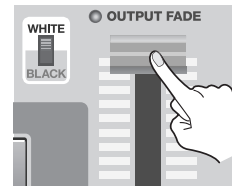

- 4 Use the INPUT SELECT buttons to switch input channels.**

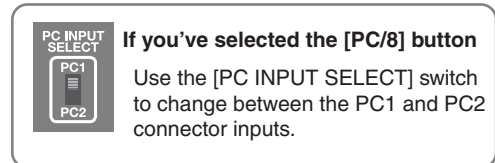
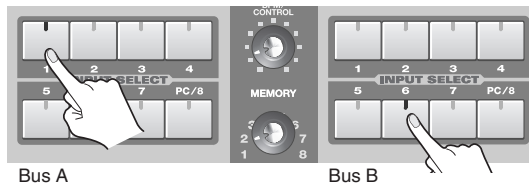

Press the INPUT SELECT button of a channel to which an image is being input. Verify that the image is correctly shown on the television monitor or projector connected to the OUTPUT connector.

Try switching the input channel, and verify that the image shown in the television monitor or projector is switched accordingly.

* The input from the S-video connector takes priority for channels 5–8.

- ① Move the video fader to the bus A position.**
- ② Switch between inputs by successively pressing the INPUT SELECT [1]–[PC/8] buttons for bus A.**
- ③ Move the video fader to the bus B position.**
- ④ Switch between inputs by successively pressing the INPUT SELECT [1]–[PC/8] buttons for bus B.**

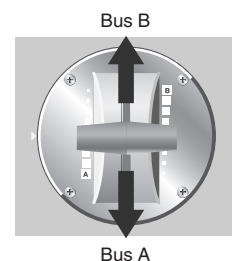

About the PC inputs

When you use the [PC INPUT SELECT] switch to switch the PC input, it will take some time for the input to stabilize. We recommend that you use a monitor to verify the image.

In addition, selecting the PC input may cause the image display position to be skewed for some computers. Use the PC input adjustment menu to adjust the screen display position. For details, refer to "Adjusting the PC Input Image" (p. 54).

* When displaying moving images from a PC input, skew or flickering may occur in the image. For details, refer to "Skewed or Flickering Images (Tearing)" (p. 55).

Blue Back Output

You can output a blue back to the final output image and to the preview of the final output image. Blue back output is switched on/off using "No Signal Blueback" in the "Utility" menu.

Value	Details
On	A blue back will be output when there is no signal.
Off	A black image will be output when there is no signal.

* For details on menu operations, refer to "Menu Operations" (p. 23).

Outputting a Preview Image

Here's how to verify that an image is correctly output to the TV monitor connected to the PREVIEW OUT connector that you're using for previewing.

- 1 Proceed as described in steps 1–3 of “Outputting Images” (p. 21).
- 2 Press the PREVIEW OUTPUT SELECT buttons to switch between preview output channels.

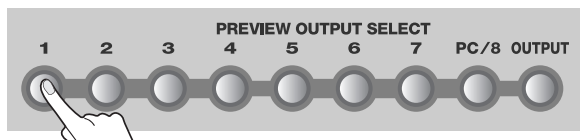

Press the PREVIEW OUTPUT SELECT button of a channel into which an image is being input. Verify that the image is correctly shown in the television monitor (preview monitor) connected to the PREVIEW OUT connector. Successively press the PREVIEW OUTPUT SELECT [1]–[PC/8] and [OUTPUT] buttons, and verify that the image in the preview monitor is switched.

	Sends the video being input via the INPUT 1–8/PC1/PC2 connectors to the preview output.
[1]–[PC/8] buttons	<ul style="list-style-type: none"> * For channels 5–8, the input from the S-video connectors will take priority. * Use the [PC INPUT SELECT] switch to change between the PC1/PC2 connector inputs.
[OUTPUT] button	Sends the final image to the preview output.

* The image in the preview monitor will momentarily be distorted when you switch the preview output, but this will not affect the final output.

Preview output when there is no signal

With the factory settings, selecting a channel for which there is no input will cause the indication “No Signal” to appear in the preview monitor. You can use the “Utility” menu item “Preview Signal Check” to turn the “No Signal” indication on/off.

Value	Details
On	<p>The “No Signal” indication will be output when there is no signal.</p> <p>You can change the background color by setting the “Utility” menu item “Preview No Signal Color.”</p> <ul style="list-style-type: none"> * You can't change the “No Signal” indication and background color for channel 8.
Off	A black image will be output if there is no signal.

* For details on menu operations, refer to “Menu Operations” (p. 23).

Selecting the preview output

You can use the “Utility” menu item “Preview Switch Pattern” to change the way in which the preview output is selected.

Value	Details
Manual	The image selected by the PREVIEW OUT SELECT button will be sent to preview output.
Prev Auto	The image of the bus (A or B) not being sent to the final output will be sent to preview output. For example, if the bus A image is being sent to the final output, the bus B image will be sent to preview output.
Always-1–8, Always-Out	<p>The preview output will be fixed at channel 1–8 or at the final output.</p> <p>While you hold down a PREVIEW OUT SELECT button, the image selected by the button will be sent from the preview output.</p>
Auto1-2–1-8, Auto1-Out	<p>The preview output will be switched automatically. For example, if you set this to “Auto1-4,” channels 1–4 will be switched automatically and sent to preview output.</p> <p>You can use the “Utility” menu item “Preview Auto Speed” to change the time at which the preview output is switched.</p>

* For details on menu operations, refer to “Menu Operations” (p. 23).

Menu Operations

By accessing menus you can make settings for the large variety of features, such as transitions and effects, that the V-8 offers.

For details on the menu items, refer to "Menu List" (p. 81).

Preparations for Viewing the Menu

The menu is shown on the TV monitor connected to the PREVIEW OUT connector. You'll need to have your TV monitor connected to the PREVIEW OUT connector and ready for use.

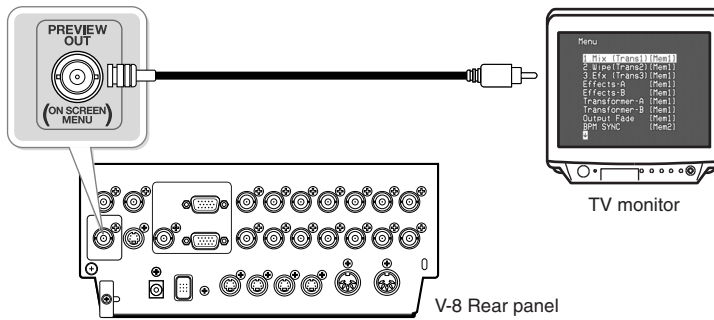

About menu levels

Menus are arranged as shown in the figure below. The value are set in the lowest level in each respective parameter.

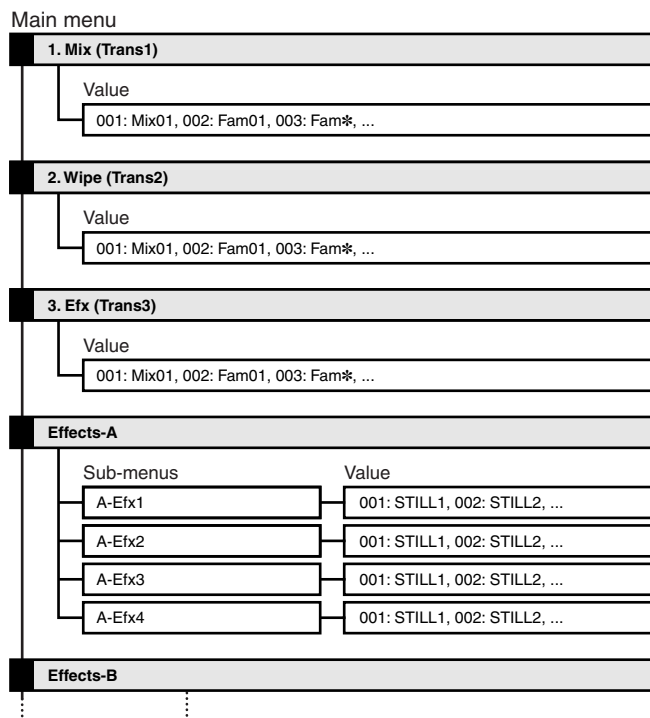

Operating the Menu

- * The “Mem2” through “Mem8” indications at the right of the menu items indicate that settings will be stored in [MEMORY] knob locations 2–8. If you want to change settings, turn the [MEMORY] knob to select the memory number 2–8 whose settings you want to change. See “Storing the Operating Panel Settings” (p. 28)
- * If “Mem 1” (memory number 1) is indicated, you won’t be able to change the contents, since these are the factory preset settings. The menu will indicate “** Preset **”.

```
Menu-Transition1[Mem1]
  ** Preset **
1.Mix 001:Mix01
  002:Fam01
  003:...
```

1 Press the [MENU] button to access the menu.

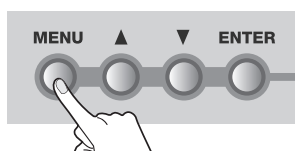

2 Use the [▲] [▼] buttons to select a menu item.

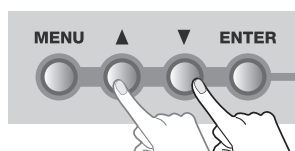

The [▲] [▼] buttons move the cursor up/down.
The menu item at the cursor will blink, indicated that it is selected.

3 Press the [ENTER] button to confirm your choice of menu item.

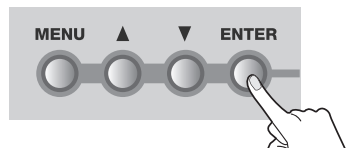

The selected menu item will be confirmed, and you’ll proceed to the next menu (a lower level).
To return to the previous menu (higher level), press the [MENU] button.

* If the menu level is deeper, repeat steps 2–3.

4 Use the [▲] [▼] buttons to edit the value.

5 Press the [MENU] button several times to close the menu.



While the menu is displayed, you can temporarily hide the menu by holding down the currently selected PREVIEW OUT SELECT button.

Saving your settings

The content of your settings is saved in the V-8's internal memory when you close the menu.

NOTE

Be aware that if you edit settings and switch off the power before closing the menu, your changes will be lost.

Locking menu operations (Memory protect)

By turning the "Utility" menu item "Memory Protect" to the "On" setting, you can prevent changes to the settings. If memory protect is on, the memory screen will indicate "*Protect On*."

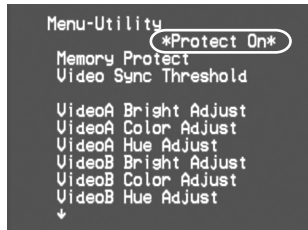

Adjusting the menu display position

You can adjust the location in which menus and settings (p. 26) are shown in the preview monitor. To make this adjustment, use the "Utility" menu items "OSD Horizontal Locate" (horizontal position) and "OSD Vertical Locate" (vertical position).

About the Current Settings Display

You can use the preview monitor to view the current settings.

These settings are displayed only while the final output image is being sent to the preview output ([OUTPUT] button is lit). Settings are not displayed while channels 1–8 are being sent to the preview output.

* You can change the contents of the information that will be displayed. The screen shown below is an example of “Mode3,” which shows the most information about the settings. For details, refer to “Changing the Contents of the Settings Display” (p. 27).

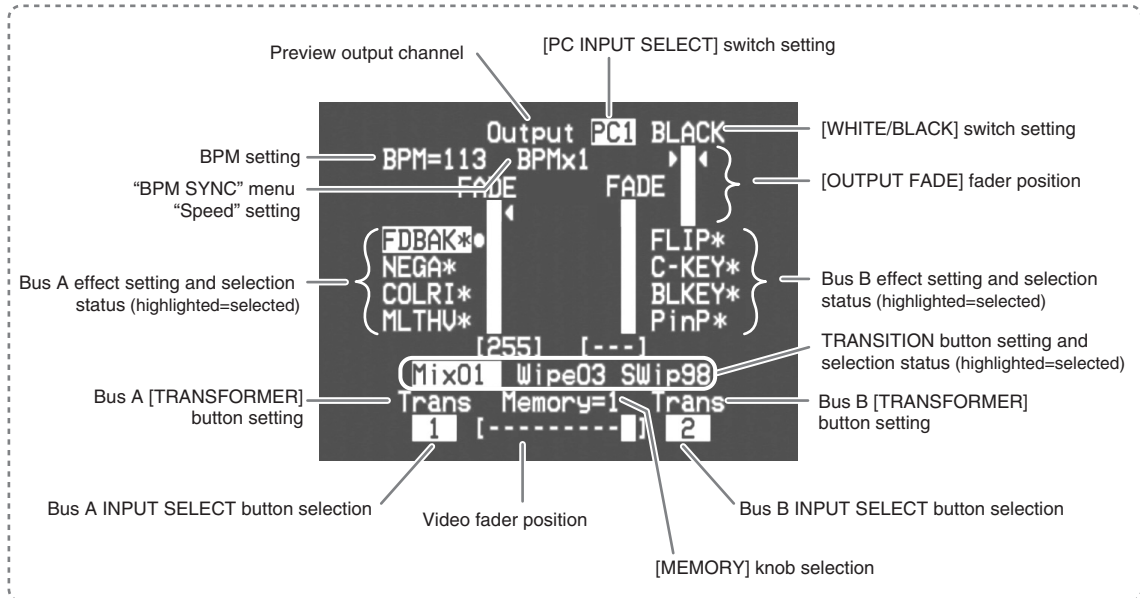

● Effect indication

If you're able to use the [CONTROL] fader to change the effect settings, a ● symbol is shown beside the effect name.

* For details on the effects whose settings you can control refer to “Effects that can be controlled by the [CONTROL] faders” (p. 42).

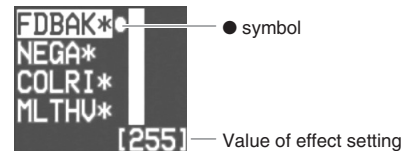

● Video fader position indication

This indication is shown when you're using the BPM Sync function (p. 60).

This indication is shown when the position of the video fader differs from the actual output.

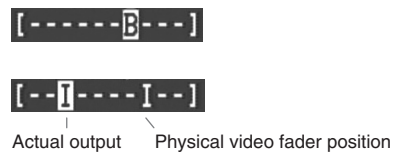

● Bus fade indication

When the [CONTROL] faders can be used to fade the bus image (p. 31), a ● symbol is shown beside the “FADE” indication.

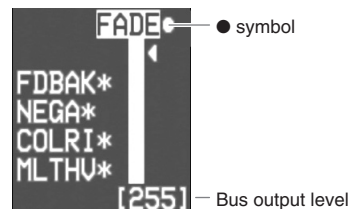

- You can cause the settings to be hidden while you hold down the [OUTPUT] button.
- The settings display is not shown while the menu is displayed (p. 24).

Changing the Contents of the Settings Display

Here's how to change the contents of the information shown in the preview monitor.

- 1 Press the [MENU] button to access the menu, and choose "Utility."



- ① Press the [MENU] button to access the menu.
- ② Use the [▲] [▼] buttons to select "Utility."
- ③ Press the [ENTER] button to confirm your selection.

- 2 Use the [▲] [▼] buttons to select "Preview Display Mode," and press the [ENTER] button.

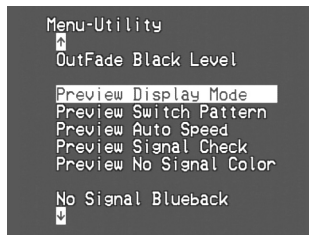

- 3 Use the [▲] [▼] buttons to select the contents of the information that will be shown in the preview monitor.

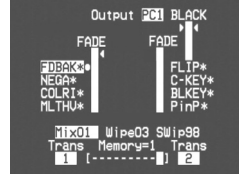
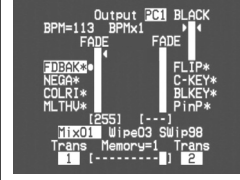
Value	No Display	Mode1	Mode2	Mode3
Details	No settings will be shown in the preview monitor.	(Display example) 	(Display example) 	(Display example) 

- 4 Press the [MENU] button several times to close the menu.

Storing the Operating Panel Settings ([MEMORY] Knob)

You can store the settings of the operating panel buttons and faders in memory locations 2–8 of the [MEMORY] knob. To recall the stored settings, simply choose the desired memory number.

The factory preset settings are assigned to memory number 1. These settings are recall-only, and can't be edited.

- * The factory preset settings match the button names printed on the operating panel. For details on the settings, refer to the section “Settings stored at the [MEMORY] knob,” later on this page.

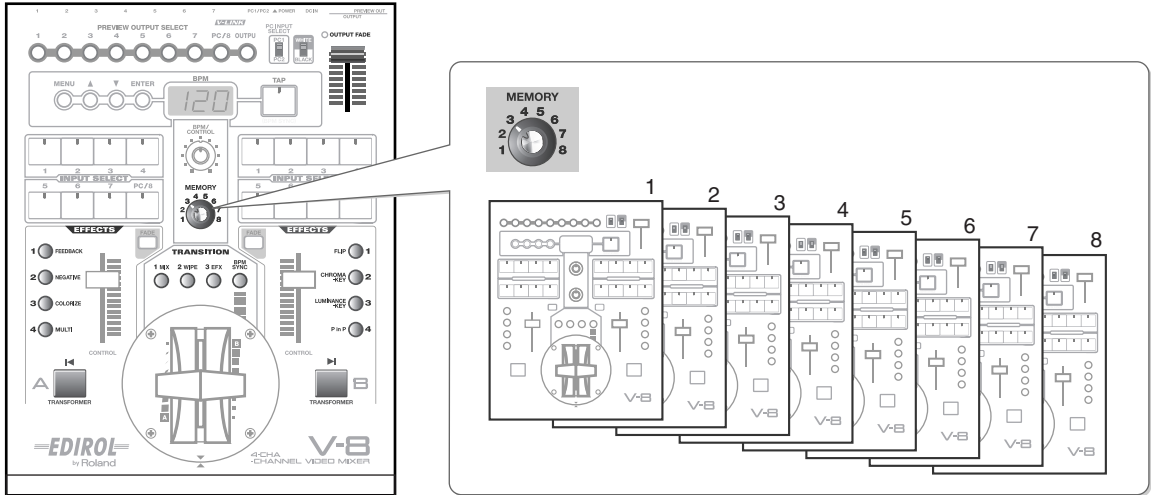

Settings Stored at the [MEMORY] Knob

Settings for the following buttons and faders are stored at the [MEMORY] knob. The settings you edit are stored immediately in the currently selected memory number. The on/off states of the EFFECTS buttons are also remembered.

Operating panel	Factory preset (memory number 1)	Stored setting	See page
TRANSITION buttons	[1 MIX]	001: Mix01	Transition effect assigned to each button. p. 36
	[2 WIPE]	008: Wipe03	
	[3 EFX]	192: SWipe88	
[BPM SYNC] button	Mode: TransitionA/B Speed: BPMx1	Transition mode and displayed BPM when using BPM sync (p. 60).	p. 62
Bus A EFFECTS buttons	[1 (FEEDBACK)]	022: FEEDBACK*	Effect setting assigned to each button. p. 53
	[2 (NEGATIVE)]	033: NEGATIVE*	
	[3 (COLORIZE)]	042: COLORIZE*	
	[4 (MULTI)]	126: MULTI-HV*	
Bus B EFFECTS buttons	[1 (FLIP)]	102: FLIP*	Effect setting assigned to each button. p. 53
	[2 (CHROMA KEY)]	098: CHROMAKEY*	
	[3 (LUMINANCE KEY)]	096: B-LUMIKEY*	
	[4 (P in P)]	150: PinP*	
Bus A [TRANSFORMER] button	02: Trans	Settings for operating the [TRANSFORMER] buttons. p. 41	
Bus B [TRANSFORMER] button	02: Trans		
[OUTPUT FADE] fader	02: Manual	Fade operation setting for the [OUTPUT FADE] fader. p. 78	
PANEL MODE	01: Video + MidiOut	Settings for whether MIDI messages will be transmitted when buttons or faders are operated. p. 67	

Recalling a Memory

- 1 Turn the [MEMORY] knob to the memory number 1–8 that you want to recall.

The settings will be recalled.

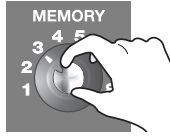

* Memory number 1 contains the factory preset settings (p. 28).

Copying the Contents of a Memory

Here's how to copy the settings of the currently selected memory number to a different memory number.

- 1 Turn the [MEMORY] knob to select the desired copy-source memory number 1–8.



* Memory number 1 contains the factory preset settings (p. 28).

- 2 Press the [MENU] button to access the menu, and choose “Memory Edit.”



- ① Press the [MENU] button to access the menu.
- ② Use the [▲] [▼] buttons to select “Memory Edit.”
- ③ Press the [ENTER] button to confirm your selection.

- 3 Use the [▲] [▼] buttons to select the desired copy-destination memory number, and press the [ENTER] button.



Copy Mem2->Mem6

Copy-source memory number Copy-destination memory number

To copy the contents of memory, choose an item that shows “Copy” at the left side. In the screen example shown here, the settings of memory number 2 will be copied to memory number 6.

You can change the copy-source memory number at this time by turning the [MEMORY] knob.

By choosing “Mem* -> All” you can copy the settings to all memory numbers 2–8.

- 4 Make sure that the display indicates “Push [ENTER],” and press [ENTER].

(If you decide to cancel, press the [MENU] button.)

The contents of memory will be copied.

- 5 Press the [MENU] button several times to close the menu.

Exchanging the Contents of Memories

Here's how to exchange the contents of the currently selected memory number with a different memory number.

- 1 Turn the [MEMORY] knob to select the desired exchange-source memory number 2–8.



* Memory number 1 contains the factory preset settings (p. 28). They cannot be exchanged with the settings of another memory number.

- 2 Press the [MENU] button to access the menu, and choose “Memory Edit.”



- ① Press the [MENU] button to access the menu.
- ② Use the [▲] [▼] buttons to select “Memory Edit.”
- ③ Press the [ENTER] button to confirm your selection.

- 3 Use the [▲] [▼] buttons to select the desired exchange-destination memory number, and press the [ENTER] button.



Exchange Mem2<->Mem8

Exchange-source memory number Exchange-destination memory number

To exchange the contents of memory, choose an item that shows “Exchange” at the left side. In the screen example shown here, the settings of memory number 2 will be exchanged with the settings of memory number 8.

You can change the exchange-source memory number at this time by turning the [MEMORY] knob.

- 4 Make sure that the display indicates “Push [ENTER],” and press [ENTER].
(If you decide to cancel, press the [MENU] button.)

The contents of the two memories will be exchanged.

- 5 Press the [MENU] button several times to close the menu.

Fading Out the Output Image

Fading Out the Bus A / Bus B Image

Here's how to fade out the image of bus A or bus B of the video mixer.

In this example we'll show the procedure for fading out the bus A image.

1 Press the bus A [FADE] button.

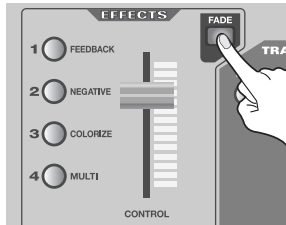

The [FADE] button will be blinking, and now you can use the bus A [CONTROL] fader to fade in/out the bus A output image.

2 Lower the bus A [CONTROL] fader.

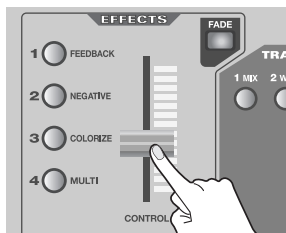

The bus A image will fade out. To fade in the image, raise the [CONTROL] fader.

* The fade color is fixed at black.

* To fade out the bus B image, operate the bus B [FADE] button and [CONTROL] fader in the same way.



In addition to controlling bus fading, the [CONTROL] fader is also used to control the effect settings (p. 42). While the EFFECTS button is blinking, operating the [CONTROL] fader will affect the effect settings.

The target of [CONTROL] fader operations (i.e., the EFFECTS button or the [FADE] button) can be switched by using the [▲] [▼] buttons. You can switch to bus A by pressing the [▲] button, or to bus B by pressing the [▼] button. The button that is blinking will be the target of [CONTROL] fader operations.

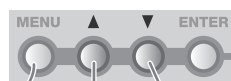

[MENU] button is
extinguished

Bus A

Bus B

Fading Out the Final Output

Here's how to fade out the final output.

- 1 Set the [MEMORY] knob to memory number 1.

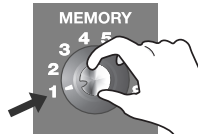

* The factory preset settings are assigned to memory number 1. For details on the [MEMORY] knob, refer to “Storing the Operating Panel Settings” (p. 28).

- 2 Lower the [OUTPUT FADE] fader.

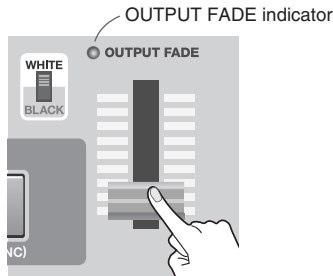

The OUTPUT FADE indicator shows the image output status.

Blinking	Currently fading in/out
Lit	Normal output

You can use the [WHITE/BLACK] switch to change the fade color.

WHITE	Fade to white
BLACK	Fade to black

The final output will fade out. To fade in the image, raise the [OUTPUT FADE] fader.

Adjusting the fade level

You can adjust the level of the white fade or black fade. This is done using the “Utility” menu items “OutFade White Level” or “OutFade Black Level.”

Setting the function of the [OUTPUT FADE] fader

You can specify what will happen when the [OUTPUT FADE] fader is operated; the final output can be automatically faded in/out, or you can disable operation of the fader.

- 1 Turn the [MEMORY] knob to select the memory number 2–8 whose setting you want to edit.

* Memory number 1 contains the factory preset settings (p. 28). These settings cannot be modified.

- 2 Press the [MENU] button to access the menu, and choose “Output Fade.”

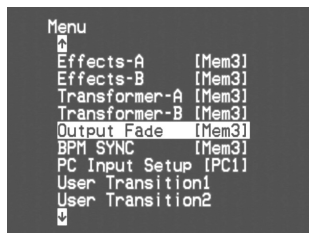

- ① Press the [MENU] button to access the menu.
- ② Use the [▲] [▼] buttons to select “Output Fade.”
- ③ Press the [ENTER] button to confirm your selection.

- 3 Use the [▲] [▼] buttons to specify the function that the [OUTPUT FADE] fader will perform.

Value	Details
No Control	[OUTPUT FADE] fader operations will be disabled.
Manual	Manually moving the [OUTPUT FADE] fader will fade in/out the final output.
Auto	Lowering the [OUTPUT FADE] fader will automatically repeat fade in/out of the final output. The farther you lower the [OUTPUT FADE] fader, the longer the interval will be between fade in/out.

- 4 Press the [MENU] button several times to close the menu.

Returning the Menu Settings to the Factory-Set State (Factory Reset)

Here's how to return the menu settings to the factory-set state (Factory Reset).

If your operations do not produce the results described in this manual, you can execute this Factory Reset operation.

- * All settings you've made will be lost when you execute a Factory Reset.

Returning All Settings to the Factory-Set State

- 1 Press the [MENU] button to access the menu, and choose "Factory Reset."



- ① Press the [MENU] button to access the menu.
- ② Use the [▲] [▼] buttons to select "Factory Reset."
- ③ Press the [ENTER] button to confirm your selection.

- 2 Use the [▲] [▼] buttons to select "Yes [ENTER] Sw," and press the [ENTER] button.
(If you decide to cancel, press the [MENU] button or select "No" and press the [ENTER] button.)

The Factory Reset will be executed.

- 3 Press the [MENU] button several times to close the menu.

Returning the Settings of a Specific Sub-Menu to the Factory-Set State

You can perform a factory reset on just the items of the individual sub-menu you specify: “PC Input Setup,” “PinP Setup,” “Key Setup,” “MIDI Setup,” or “Utility.” Refer to the following table, and choose “** Reset” from the sub-menu.

Main menu	Sub-menu
PC Input Setup	PC Reset
PinP Setup	PinP-Reset
Key Setup	Key Reset
MIDI Setup	MIDI Reset
Utility	Utility Reset

The example here describes how to perform a factory reset on the “Utility” sub-menu.

1 Press the [MENU] button to access the menu, and choose “Utility.”

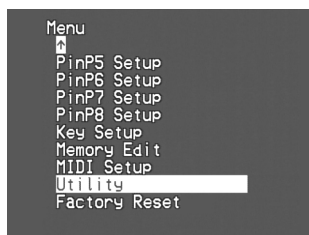

- ① Press the [MENU] button to access the menu.
- ② Use the [▲] [▼] buttons to select “Utility.”
- ③ Press the [ENTER] button to confirm your selection.

2 Use the [▲] [▼] buttons to choose “Utility Reset,” and press the [ENTER] button.

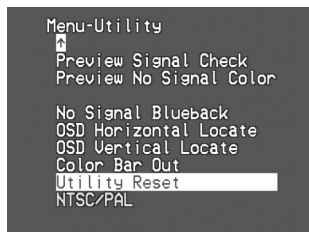

3 Use the [▲] [▼] buttons to choose “Yes [ENTER] Sw,” and press the [ENTER] button. (If you decide to cancel, press the [MENU] button or choose “No” and press the [ENTER] button.)

A factory reset will be executed for the “Utility” sub-menu.

4 Press the [MENU] button several times to close the menu.

Switching Between Images

Switching Between Two Images

Here's how to switch between the images being input to bus A and bus B of the video mixer.

1 Set the [MEMORY] knob to memory number 1.

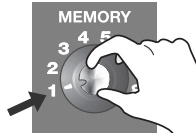

* The factory preset settings are assigned to memory number 1. For details on the [MEMORY] knob, refer to "Storing the Operating Panel Settings" (p. 28).

2 Use the INPUT SELECT buttons to select the images input to bus A and bus B.

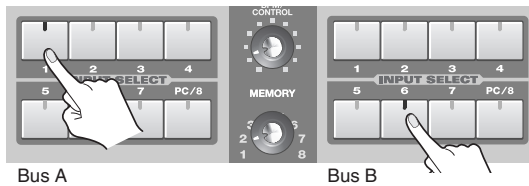

If you've selected the [PC/8] button

Use the [PC INPUT SELECT] switch to change between the PC1 and PC2 connector inputs.

* When you use the [PC INPUT SELECT] switch to switch the PC input, it will take some time for the input to stabilize. We recommend that you use a monitor to verify the image.

* If you want to adjust the display position or other aspects of the PC input screen, refer to "Adjusting the PC Input Image" (p. 54).

3 Use the TRANSITION buttons to select the desired transition effect.



Press one of the [1 MIX] [2 WIPE] [3 EFX] buttons to select the desired transition. The selected button will light.

* With the factory presets, the TRANSITION buttons are assigned the following transition effects.

Button	Menu item	Value	Effect
[1 MIX] button	1. Mix (Trans1)	001: Mix01	Dissolve
[2 WIPE] button	2. Wipe (Trans2)	008: Wipe03	Wipe
[3 EFX] button	3. Efx (Trans3)	192: SWipe88	Soft edge wipe

* You can change the transition effect that's assigned to each TRANSITION button. For details, refer to "Changing the Transition Assigned to Each TRANSITION Button" (p. 36).

* Depending on the type of transition and effect (p. 42), there are some combinations that cannot be used simultaneously. For details, refer to "Effects that Cannot Be Used Simultaneously" (p. 107).

4 Operate the video fader to switch between the images of bus A and bus B.

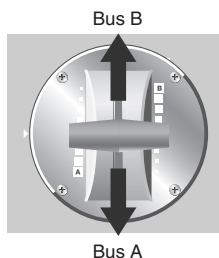

To output the bus A image, move the video fader toward bus A.

To output the bus B image, move the video fader toward bus B.

When using the INPUT SELECT buttons to switch images

If the video fader is not fully toward the bus A or bus B position, using the INPUT SELECT buttons to switch channels will cause the image to be distorted, but this is not a malfunction.

Take the following action and make the following settings before using the INPUT SELECT buttons to switch images. This will allow you to switch smoothly between images without any switching noise.

- Set the video fader all the way toward the bus A or bus B position (the bus that is outputting the video).
- Raise the value of the "Utility" menu item "Input Select Delay Time."

Changing the Transition Assigned to Each TRANSITION Button

You can change the transition effect that's assigned to each TRANSITION button ([1 MIX] [2 WIPE] [3 EFX] buttons).

- 1 Turn the [MEMORY] knob to select the memory number 2–8 whose settings you want to edit.



* Memory number 1 contains the factory preset settings (p. 28). These settings cannot be modified.

- 2 Press the [MENU] button to access the menu, and choose “1. Mix (Trans1),” “2. Wipe (Trans2),” or “3. Efx (Trans3).”

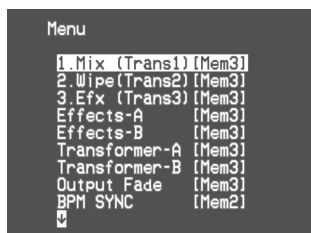

- 1 Press the [MENU] button to access the menu.
- 2 Use the [▲] [▼] buttons to select “1. Mix (Trans1),” “2. Wipe (Trans2),” or “3. Efx (Trans3).”

Choose the menu item for the button whose settings you want to change.

Button	Menu item
[1 MIX] button	1. Mix (Trans1)
[2 WIPE] button	2. Wipe (Trans2)
[3 EFX] button	3. Efx (Trans3)

- 3 Press the [ENTER] button to confirm your selection.

- 3 Use the [▲] [▼] buttons to choose the desired transition effect.

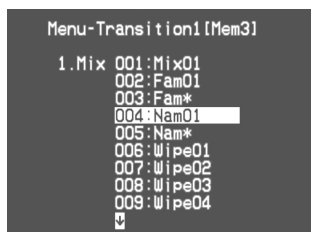

You can move the video fader back and forth to view the currently selected transition effect in the final output image. For details on the transition effects, refer to “Transition Effect List” (p. 99).

- 4 Press the [MENU] button several times to close the menu.



- If you've chosen “003: Fam*” or “005: Nam*” as the effect selected by a TRANSITION button, you'll be able to use the [BPM/CONTROL] knob to adjust the way in which the transition occurs. For details, refer to “About the FAM and NAM Transition Effects” (p. 37).
- Transition effects “260: User01”–“263: User04” allow you to combine eight transition effects to create your own original transition pattern. The eight transition effects will change according to the position of the video fader. For details, refer to “Combining Multiple Transition Effects (User Transition)” (p. 38).
- If you're using the transition effects “234: Stretch01”–“259: Stretch26,” the image quality of the image that is being stretched or diminished will be slightly decreased during the transition.

About the FAM and NAM Transition Effects

The transition effects built into the V-8 include FAM (Full Additive Mix) and NAM (Non-Additive Mix). Speaking simply, FAM and NAM are special dissolve transitions that compare the brightness (luminance) of two images in order to determine the degree of compositing.

- Dissolve transition (001: Mix01)

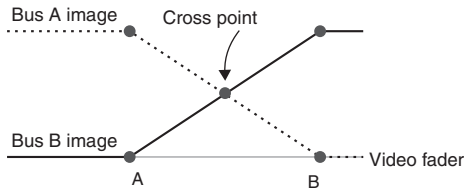

- FAM transition (002: Fam01, 003: Fam*)
- NAM transition (004: Nam01, 005: Nam*)

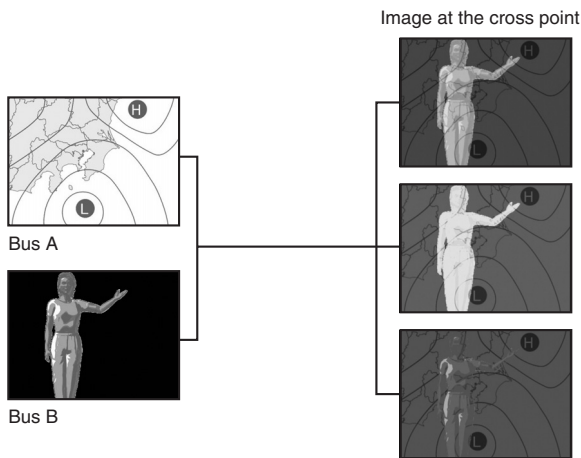
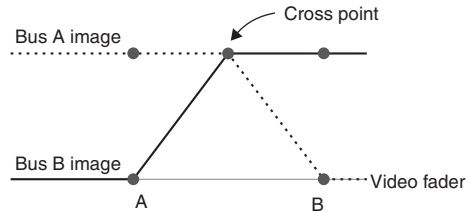

Dissolve transition

The transition between images takes place by simply raising or lowering the video level. The luminance of the composite image will be less in the region of the cross point.

FAM transition

The images will transition with the luminance level held steady.

NAM transition

The two images will be compared, and the pixels that have a higher brightness level will be shown while the images are switched.

Changing the cross point of the FAM/NAM (003: Fam*, 005: Nam*)

If you select "003: Fam*" or "005: Nam*" which have an "*" (asterisk) following the transition name, you'll be able to use the [BPM/CONTROL] knob to change the cross point of the FAM/NAM.

At this time, the FAM/NAM cross point level will blink in the BPM display. The cross point level range is 0–100.

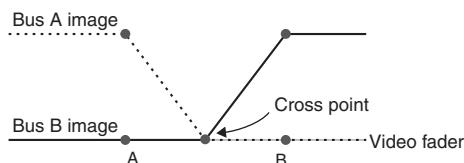
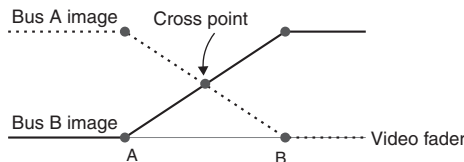
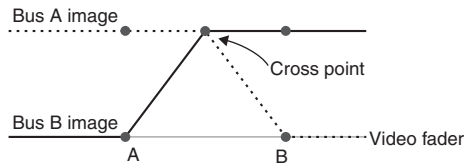
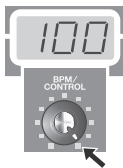

Combining Multiple Transition Effects (User Transition)

Transition effects “260: User01”–“263: User04” allow you to combine eight transition effects to create your own original transition pattern. Each of the eight transition effects are assigned to one eighth of the fader stroke. When you operate the video fader, the transition effect will change depending on the fader position.

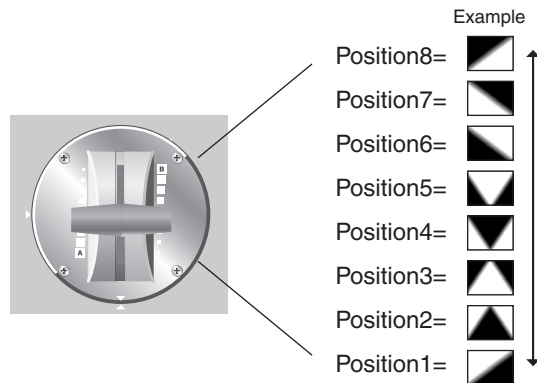

- 1 Press the [MENU] button to access the menu, and choose “User Transition1”–“User Transition4.”

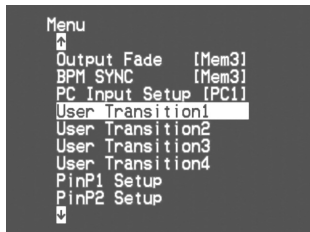

- 1 Press the [MENU] button to access the menu.
- 2 Use the [▲] [▼] buttons to select “User Transition1”–“User Transition4.”

Choose the menu item for the transition effect that you want to edit.

Transition effects	Menu item
260: User01	User Transition1
261: User02	User Transition2
262: User03	User Transition3
263: User04	User Transition4

- 3 Press the [ENTER] button to confirm your selection.

- 2 Use the [▲] [▼] buttons to select one of the eight video fader positions, and press the [ENTER] button.

Menu item	Details
Position1	Specifies the transition effect for position 1.
Position2	Specifies the transition effect for position 2.
Position3	Specifies the transition effect for position 3.
Position4	Specifies the transition effect for position 4.
Position5	Specifies the transition effect for position 5.
Position6	Specifies the transition effect for position 6.
Position7	Specifies the transition effect for position 7.
Position8	Specifies the transition effect for position 8.

- 3 Use the [▲] [▼] buttons to specify the transition effect for each position.

- 4 Press the [MENU] button several times to close the menu.

User transition switching function

You can automatically switch between the eight transitions that comprise the user transitions (p. 38) in synchronization with the BPM. When doing so, the effects will switch in the order of the Position 1–8 settings (steps 2–3 on the preceding page).

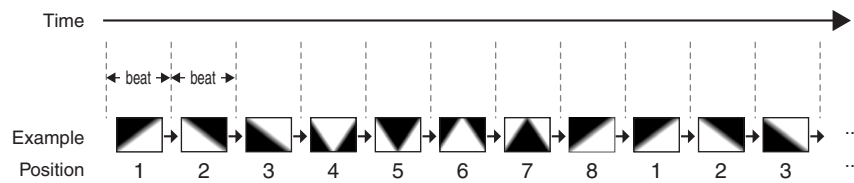

- 1 Press the [MENU] button to access the menu, and choose “User Transition1”–“User Transition4.”

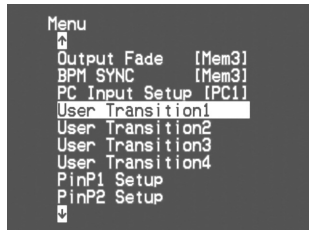

- 1 Press the [MENU] button to access the menu.
- 2 Use the [▲] [▼] buttons to select “User Transition1”–“User Transition4.”

Choose the menu item for the transition effect that you want to edit.

Transition effects	Menu item
260: User01	User Transition1
261: User02	User Transition2
262: User03	User Transition3
263: User04	User Transition4

- 3 Press the [ENTER] button to confirm your selection.

- 2 Use the [▲] [▼] buttons to select “Switching,” and press [ENTER].

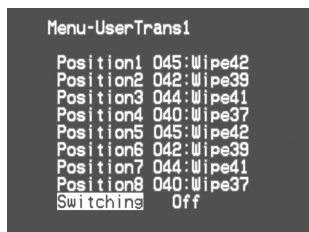

- 3 Use the [▲] [▼] buttons to turn the switching function on/off.

Menu item	Details
Off	The transition effect will change according to the position of the video fader (p. 38).
BPMx1	The effects will switch at the same rate as the displayed BPM.
BPMx2	The effects will switch at double the rate of the displayed BPM.
BPMx4	The effects will switch at four times the rate of the displayed BPM.

- 4 Press the [MENU] button several times to close the menu.
- 5 Turn the [BPM/CONTROL] knob or press the [TAP] button to specify the BPM.

Using the [TRANSFORMER] Buttons to Switch Images

Here's how you can use the [TRANSFORMER] buttons to switch images without using the video fader.

1 Set the [MEMORY] knob to memory number 1.

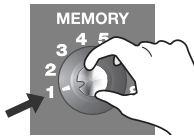

* The factory preset settings are assigned to memory number 1. For details on the [MEMORY] knob, refer to "Storing the Operating Panel Settings" (p. 28).

2 Use the INPUT SELECT buttons to select the images that you want to input to bus A and bus B.

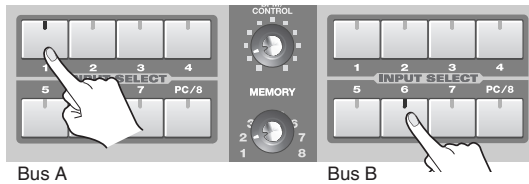



If you've selected the [PC/8] button

Use the [PC INPUT SELECT] switch to change between the PC1 and PC2 connector inputs.

* When you use the [PC INPUT SELECT] switch to switch the PC input, it will take some time for the input to stabilize. We recommend that you use a monitor to verify the image.

* If you want to adjust the display position or other aspects of the PC input screen, refer to "Adjusting the PC Input Image" (p. 54).

3 Operate the video fader to output either bus A or bus B.

Set the video fader all the way to either bus A or bus B.

4 Press a [TRANSFORMER] button to switch between the bus A or bus B images.

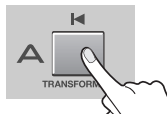

If the video fader is in the bus B position:

The bus A image will be output only while you hold down the bus A [TRANSFORMER] button.



If the video fader is in the bus A position:

The bus B image will be output only while you hold down the bus B [TRANSFORMER] button.

* With the factory preset settings, the [TRANSFORMER] buttons are assigned to operate as follows.

Menu item	Setting	Details
Transformer-A	02: Trans	The image of the bus whose [TRANSFORMER] button you hold down will be output.
Transformer-B	02: Trans	

* You can change the operation (the image switching pattern) produced by pressing the [TRANSFORMER] button. You can also assign a TRANSITION button or EFFECTS button to the [TRANSFORMER] button, and use it to control a transition or effect.

For details, refer to "Changing the assignment of the [TRANSFORMER] buttons" on the following page.

Changing the Assignment of the [TRANSFORMER] Buttons

You can change the duration or operation of the transition that occurs when you use the [TRANSFORMER] buttons to switch between images.

You can also assign a TRANSITION button or EFFECTS button to a [TRANSFORMER] button, and use it to control a transition or effect.

1 Turn the [MEMORY] knob to select the memory number 2–8 whose settings you want to edit.

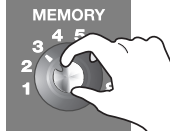

* Memory number 1 contains the factory preset settings (p. 28). These settings cannot be modified.

2 Press the [MENU] button to access the menu, and choose “Transformer-A” or “Transformer-B.”



- ① Press the [MENU] button to access the menu.
- ② Use the [▲] [▼] buttons to select “Transformer-A” or “Transformer-B.”

Choose the menu item for the button whose setting you want to edit.

Button	Menu item
Bus A [TRANSFORMER] button	Transformer-A
Bus B [TRANSFORMER] button	Transformer-B

- ③ Press the [ENTER] button to confirm your selection.

3 Use the [▲] [▼] buttons to specify the operation of the [TRANSFORMER] button.

Value	Details
01: None	The [TRANSFORMER] button will not do anything.
02: Trans	The image of the bus whose button you press will be output as long as you hold down the [TRANSFORMER] button.
03: A<->9 – 12: A<->0 *1	The bus A and bus B images will alternate each time you press the [TRANSFORMER] button.
03: 9<->B – 12: 0<->B *1	
13: A<-9 – 22: A<-0 *1	The output will switch to the bus A image when you press the [TRANSFORMER] button.
13: 9->B – 22: 0->B *1	The output will switch to the bus B image when you press the [TRANSFORMER] button.
23: A->9 – 32: A->0 *1	The output will switch to the bus B image when you press the [TRANSFORMER] button.
23: 9<-B – 32: 0<-B *1	The output will switch to the bus A image when you press the [TRANSFORMER] button.
33: White	A white image will be output while you hold down the [TRANSFORMER] button.
34: Black	A black image will be output while you hold down the [TRANSFORMER] button.
35: MIX	The [1 MIX] button will be selected while you hold down the [TRANSFORMER] button.
36: WIPE	The [2 WIPE] button will be selected while you hold down the [TRANSFORMER] button.
37: EFX	The [3 EFX] button will be selected while you hold down the [TRANSFORMER] button.
38: EFXA1 – 41: EFXA4 *2	The bus A EFFECTS button will turn on while you hold down the [TRANSFORMER] button.
38: EFXB1 – 41: EFXB4 *2	The bus B EFFECTS button will turn on while you hold down the [TRANSFORMER] button.

*1 The numbers 0–9 indicate the time taken by the transition. Higher numbers produce a longer transition time.

*2 The numbers 1–4 indicate the number of an EFFECTS button.

4 Press the [MENU] button several times to close the menu.



If you use the [TRANSFORMER] buttons or BPM Sync (p. 60) to switch images automatically, there will be situations in which the position of the video fader will not match the actual output. If you set the “Utility” menu item “Video Fader Mode” to “Quick,” the output will change to match the fader position when you move the video fader slightly (p. 78).

Using Effects

About Effects

The number of effects that can be used simultaneously

You can simultaneously use up to four effects for bus A and four effects for bus B.

However, depending on the type of effect, there are some combinations that cannot be used simultaneously. There are also some cases in which a transition (p. 35) and an effect cannot be used simultaneously. For details, refer to “Effects that Cannot Be Used Simultaneously” (p. 107).

Effect types

The V-8 provides 150 different effects, including compositing effects, filter effects, and motion effects.

In this manual we explain the effects using the factory presets (p. 28) as examples, but you can use other effects by assigning different effects to the EFFECTS buttons.

For details on how to assign different effects to the EFFECTS buttons, refer to “Assigning Different Effects to the EFFECTS Buttons” (p. 53).

Effects that can be controlled by the [CONTROL] faders

If you choose an effect that has an “*” (asterisk) following its name, you’ll be able to control it using the [CONTROL] fader. In this case, the EFFECTS button will blink, indicating that you can use the [CONTROL] fader to modify the effect.

For details on the effect parameter that is controlled, refer to “Effects that Can Be Controlled by the [CONTROL] Fader” (p. 106).



- * The effect settings are stored in the V-8 when you turn off the effect. When you once again turn the effect on, the stored settings will be applied regardless of the position of the [CONTROL] fader.
- * In addition to controlling the effect settings, the [CONTROL] fader is also used to control bus fading operations (p. 31). While the [FADE] button is blinking, operating the [CONTROL] fader will fade in/out the bus image.
- * The target of [CONTROL] fader operations (i.e., the EFFECTS button or the [FADE] button) can be switched by using the [▲] [▼] buttons. You can switch to bus A by pressing the [▲] button, or to bus B by pressing the [▼] button. The button that is blinking will be the target of [CONTROL] fader operations.

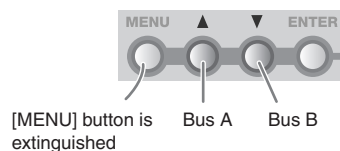

This unit allows you to switch images or turn video effects on/off at high speed. For some people, viewing such images can cause headache, nausea, or other discomfort. Do not use this unit to create video that might cause these types of health problems. Roland Corporation will accept no responsibility for any such health problems that may occur in yourself or in viewers.

Combining Two Images

You can use Picture In Picture (P in P), Chroma-key, or Luminance-key to combine the images of bus A and bus B.

Using Picture In Picture (P in P) to Combine Images

The image of the bus to which you apply the Picture In Picture (P in P) effect becomes the subscreen image, which will be displayed in miniature over the image of the other bus (the background image).

- 1 Set the [MEMORY] knob to memory number 1.



* The factory preset settings are assigned to memory number 1. For details on the [MEMORY] knob, refer to “Storing the Operating Panel Settings” (p. 28).

- 2 Press a bus A INPUT SELECT button to select the background image.
- 3 Press a bus B INPUT SELECT button to select the subscreen image.
- 4 Press the bus B EFFECTS [4 (P in P)] button to turn on the P in P effect.

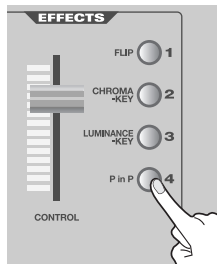

The [4 (P in P)] button will blink.

- 5 Move the video fader to the bus B position.

The bus B image will be the subscreen image, and will be combined with the bus A image (background image) and output.

- 6 Operate the bus B [CONTROL] fader to change the position of the subscreen.

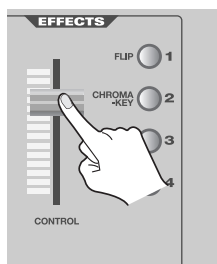

* The blinking of the [4 (P in P)] button indicates that you can use the [CONTROL] fader to change the position of the subscreen (eight types). The position of the subscreen will reflect the “142: PinP1”–“149: PinP8” setting (p. 44).

- 7 Press the [4 (P in P)] button once again to turn off the P in P effect.

The [4 (P in P)] button will go out.



- For each bus, you can use up to four effects simultaneously. However, there are some combinations of effects that cannot be used simultaneously. For details, refer to “Effects that Cannot Be Used Simultaneously” (p. 107).
- For details on how to specify the location and size of the subscreen, refer to “Detailed settings for the P in P effect” (p. 44).
- You can change the effect that is assigned to the [4 (P in P)] button. For details, refer to “Assigning Different Effects to the EFFECTS Buttons” (p. 53).
- When you turn the PinP effect on, the transition effects for the TRANSITION buttons will all be temporarily set to “Mix01.”
- When using P in P to composite the images of bus A and bus B as described above, you can't use the bus A [CONTROL] fader to fade out (p. 31) the bus A image (the background image).

Detailed settings for the P in P effect

Eight patterns (“142: PinP1”–“149: PinP8”) are provided for the P in P effect. For each one, you can specify the position and size of the subscreen.

1 Press the [MENU] button to access the menu, and choose “PinP1 Setup”–“PinP8 Setup.”

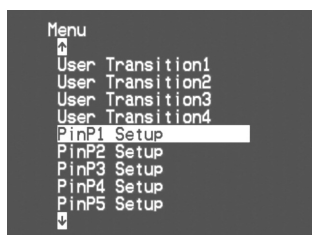

- ① Press the [MENU] button to access the menu.
- ② Use the [▲] [▼] buttons to select “PinP1 Setup”–“PinP8 Setup.”
Select the menu item for the PinP effect whose settings you want to edit.

PinP effect	Menu item	PinP effect	Menu item
142: PinP1	PinP Setup1	146: PinP5	PinP Setup5
143: PinP2	PinP Setup2	147: PinP6	PinP Setup6
144: PinP3	PinP Setup3	148: PinP7	PinP Setup7
145: PinP4	PinP Setup4	149: PinP8	PinP Setup8

- ③ Press the [ENTER] button to confirm your selection.

2 Referring to the table below, use the [▲] [▼] buttons to select the item that you want to edit, and press the [ENTER] button.

Menu item	Details
PinP-Hposi	Adjusts the horizontal position of the subscreen.
PinP-Vposi	Adjusts the vertical position of the subscreen.
PinP-4:3 HVsize	Adjusts the size of the subscreen with the aspect ratio fixed at 4:3.
PinP-Hsize	Adjusts the horizontal size of the subscreen.
PinP-Vsize	Adjusts the vertical size of the subscreen.
PinP-Border *1	Adjusts the border width of the subscreen.
PinP-BColor *1	Specifies the border color of the subscreen.
PinP-Shadow *1	Adjusts the shadow length for the subscreen.
PinP-SColor *1	Specifies the shadow color for the subscreen.
PinP-Trimming	Adjusts the trimming region for the subscreen.
PinP-Reset	Returns the sub-menu settings to the factory-set state (p. 34).

*1 If a key-compositing effect (W-LUMIKEY, B-LUMIKEY, CHROMAKEY) is on, the border and shadow of the subscreen will not be shown.

3 Use the [▲] [▼] buttons to specify the desired position, size, etc., of the subscreen.

4 Press the [MENU] button several times to close the menu.

Using Chroma-Key to Combine Images

When you apply chroma-key compositing to the image of a bus, the area of the key color will become transparent, and the image will be combined with the image of the other bus.

1 Set the [MEMORY] knob to memory number 1.

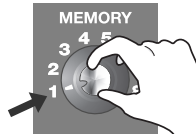

* The factory preset settings are assigned to memory number 1. For details on the [MEMORY] knob, refer to “Storing the Operating Panel Settings” (p. 28).

2 Press a bus A INPUT SELECT button to select the background image.

3 Press a bus B INPUT SELECT button to select the image that you want to key-composite.

4 Press the bus B EFFECTS [2 (CHROMA KEY)] button to turn on the Chroma-key effect.

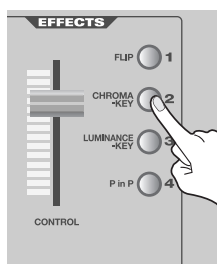

The [2 (CHROMA KEY)] button will blink.

5 Move the video fader to the bus B position.

The Chroma-key effect will be applied to the bus B image, and it will be combined with the bus A image and output.

6 Operate the bus B [CONTROL] fader to adjust the key level.

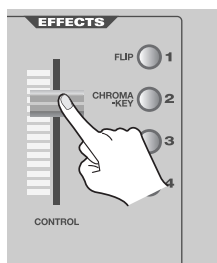

* The [2 (CHROMA KEY)] button blinks to indicate that you can use the [CONTROL] fader to control the Chroma-key level.

7 Press the [2 (CHROMA KEY)] button once again to turn off the Chroma-key effect.

The [2 (CHROMA KEY)] button will go out.



- For each bus, you can use up to four effects simultaneously. However, there are some combinations of effects that cannot be used simultaneously. For details, refer to “Effects that Cannot Be Used Simultaneously” (p. 107).
- For details on specifying the key color and edge level, refer to “Detailed settings for key-compositing effects” (p. 47).
- You can change the effect that is assigned to the [2 (CHROMA KEY)] button. For details, refer to “Assigning Different Effects to the EFFECTS Buttons” (p. 53).
- When using chroma-key to composite the images of bus A and bus B as described above, you can’t use the bus A [CONTROL] fader to fade out (p. 31) the bus A image.

Using Luminance-Key to Combine Images

When you apply luminance-key compositing to the image of a bus, the bright (or dark) area will become transparent, and the image will be combined with the image of the other bus.

1 Set the [MEMORY] knob to memory number 1.

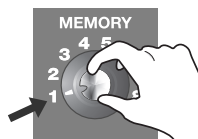

* The factory preset settings are assigned to memory number 1. For details on the [MEMORY] knob, refer to “Storing the Operating Panel Settings” (p. 28).

2 Press a bus A INPUT SELECT button to select the background image.

3 Press a bus B INPUT SELECT button to select the image that you want to key-composite.

4 Press the bus B EFFECTS [3 (LUMINANCE KEY)] button to turn on the luminance-key effect.

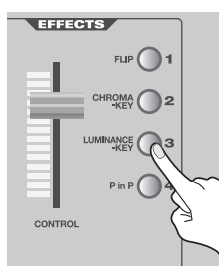

The [3 (LUMINANCE KEY)] button will blink.

5 Move the video fader to the bus B position.

The Luminance-key effect will be applied to the bus B image, and it will be combined with the bus A image and output.

6 Operate the bus B [CONTROL] fader to adjust the white luminance level.

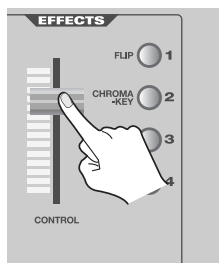

* The [3 (LUMINANCE KEY)] button blinks to indicate that you can use the [CONTROL] fader to control the white luminance level.

7 Press the [3 (LUMINANCE KEY)] button once again to turn off the Luminance-key effect.

The [3 (LUMINANCE KEY)] button will go out.



- For each bus, you can use up to four effects simultaneously. However, there are some combinations of effects that cannot be used simultaneously. For details, refer to “Effects that Cannot Be Used Simultaneously” (p. 107).
- To adjust the luminance level or edge level, refer to “Detailed settings for key-compositing effects” (p. 47).
- You can change the effect that is assigned to the [3 (LUMINANCE KEY)] button. For details, refer to “Assigning Different Effects to the EFFECTS Buttons” (p. 53).
- When using luminance-key to composite the images of bus A and bus B as described above, you can't use the bus A [CONTROL] fader to fade out (p. 31) the bus A image.

Detailed settings for key-compositing effects

You can make detailed settings such as key color and luminance when using Chroma-key or Luminance-key to combine images.

1 Press the [MENU] button to access the menu, and choose “Key Setup.”



- ① Press the [MENU] button to access the menu.
- ② Use the [▲] [▼] buttons to select “Key Setup.”
- ③ Press the [ENTER] button to confirm your selection.

2 Referring to the table below, use the [▲] [▼] buttons to select the item you want to edit, and press the [ENTER] button.

Menu item	Details
White-LumiKey Level	Adjusts the level for luminance keying (extract white).
White-LumiKey Edge	Adjusts the soft edge level for luminance keying (extract white).
Black-LumiKey Level	Adjusts the level for luminance keying (extract black).
Black-LumiKey Edge	Adjusts the soft edge level for luminance keying (extract black).
ChromaKey Color	Specify the key color for chroma keying.
ChromaKey Level	Adjust the key level for chroma keying.
ChromaKey Edge	Adjust the soft edge level for chroma keying.
Silhouette Level	When using effects “052: SILHOUETTE1”–“060: SILHOUETTE*,” adjusts the threshold value of the area between the dark and light areas of the image.
Key Reset	Returns the sub-menu settings to the factory-set state (p. 34).

3 Use the [▲] [▼] buttons to specify the desired the key color, edge level, etc.

4 Press the [MENU] button several times to close the menu.

Changing the Color of the Image

Inverting the Image to Form a Negative

You can invert the brightness and color of the image to turn it into a negative.

- 1 Set the [MEMORY] knob to memory number 1.

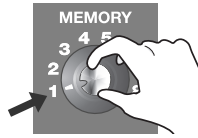

* The factory preset settings are assigned to memory number 1. For details on the [MEMORY] knob, refer to "Storing the Operating Panel Settings" (p. 28).

- 2 Press a bus A INPUT SELECT button to select an image.
- 3 Move the video fader to the bus A position to output the bus A image.
- 4 Press the bus A EFFECTS [2 (NEGATIVE)] button to turn on the Negative effect.

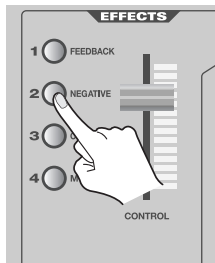

The [2 (NEGATIVE)] button will blink, and the Negative effect will be applied to the bus A output image.

- 5 Operate the bus A [CONTROL] fader to modify the brightness inversion or color inversion.

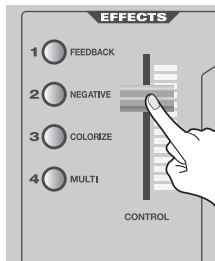

* The blinking of the [2 (NEGATIVE)] button indicates that you can use the [CONTROL] fader to modify the brightness inversion or color inversion.

- 6 Press the [2 (NEGATIVE)] button once again to turn off the Negative effect.

The [2 (NEGATIVE)] button will go out.



- For each bus, you can use up to four effects simultaneously. However, there are some combinations of effects that cannot be used simultaneously. For details, refer to "Effects that Cannot Be Used Simultaneously" (p. 107).
- You can change the effect that is assigned to the [2 (NEGATIVE)] button. For details, refer to "Assigning Different Effects to the EFFECTS Buttons" (p. 53).

Adding Color According to the Brightness or Darkness of the Image (Colorize)

You can add color according to the brightness or darkness of the image, making the image more colorful.

- 1 Set the [MEMORY] knob to memory number 1.

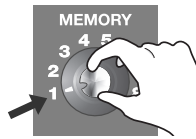

* The factory preset settings are assigned to memory number 1. For details on the [MEMORY] knob, refer to “Storing the Operating Panel Settings” (p. 28).

- 2 Press a bus A INPUT SELECT button to select an image.
- 3 Move the video fader to the bus A position to output the bus A image.
- 4 Press the bus A EFFECTS [3 (COLORIZE)] button to turn on the Colorize effect.

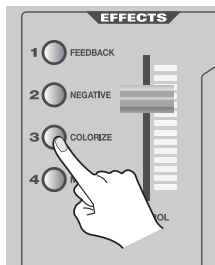

The [3 (COLORIZE)] button will blink, and the Colorize effect will be applied to the bus A output image.

- 5 Operate the bus A [CONTROL] fader to change the colorization pattern.

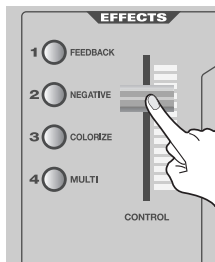

* The blinking of the [3 (COLORIZE)] button indicates that you can use the [CONTROL] fader to change colorization patterns (eight types).

- 6 Press the [3 (COLORIZE)] button once again to turn off the Colorize effect.

The [3 (COLORIZE)] button will go out.



- For each bus, you can use up to four effects simultaneously. However, there are some combinations of effects that cannot be used simultaneously. For details, refer to “Effects that Cannot Be Used Simultaneously” (p. 107).
- You can change the effect that is assigned to the [3 (COLORIZE)] button. For details, refer to “Assigning Different Effects to the EFFECTS Buttons” (p. 53).

Repeatedly Layering an Image onto Itself (Feedback)

By returning the output image of a video mixer back to the input and mixing it with the original image, you can produce the effect of the image repeatedly layered with itself (Feedback). Here's how to produce this effect on the V-8.

1 Set the [MEMORY] knob to memory number 1.

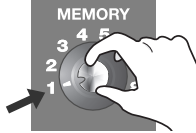

* The factory preset settings are assigned to memory number 1. For details on the [MEMORY] knob, refer to "Storing the Operating Panel Settings" (p. 28).

2 Press a bus A INPUT SELECT button to select an image.

3 Move the video fader to the bus A position to output the bus A image.

4 Press the bus A EFFECTS [1 (FEEDBACK)] button to turn on the Feedback effect.

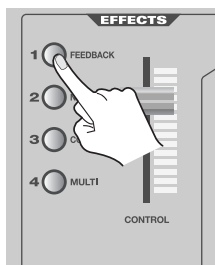

The [1 (FEEDBACK)] button will blink, and the Feedback effect will be applied to the bus A output image.

* Since Feedback is an effect that repeatedly layers the image onto itself, the effect will gradually become stronger.

5 Operate the bus A [CONTROL] fader to change the strength of the Feedback effect.

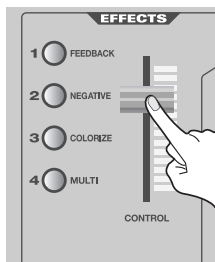

* The blinking of the [1 (FEEDBACK)] button indicates that you can use the [CONTROL] fader to change the strength (four levels) of the Feedback effect.

6 Press the [1 (FEEDBACK)] button once again to turn off the Feedback effect.

The [1 (FEEDBACK)] button will go out.



- For each bus, you can use up to four effects simultaneously. However, there are some combinations of effects that cannot be used simultaneously. For details, refer to "Effects that Cannot Be Used Simultaneously" (p. 107).
- You can change the effect that is assigned to the [1 (FEEDBACK)] button. For details, refer to "Assigning Different Effects to the EFFECTS Buttons" (p. 53).
- Since Feedback is an effect that repeatedly layers the image onto itself, even the darker areas of the image may become lighter. If you want to preserve the dark areas of the image, use "AFTERIMAGE."

Using Multi-Screen

You can divide the screen horizontally and vertically to display the input image.

- 1 Set the [MEMORY] knob to memory number 1.

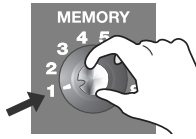

* The factory preset settings are assigned to memory number 1. For details on the [MEMORY] knob, refer to “Storing the Operating Panel Settings” (p. 28).

- 2 Press a bus A INPUT SELECT button to select an image.
- 3 Move the video fader to the bus A position to output the bus A image.
- 4 Press the bus A EFFECTS [4 (MULTI)] button to turn on the Multi-screen effect.

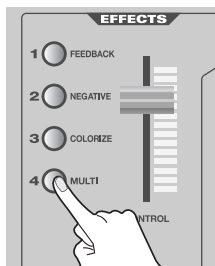

The [4 (MULTI)] button will blink, and the multi-screen effect will be applied to the bus A output image.

- 5 Operate the bus A [CONTROL] fader to change the dividing pattern for the screen.

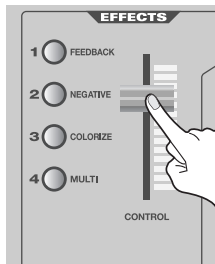

* The blinking of the [4 (MULTI)] button indicates that you can use the [CONTROL] fader to switch between dividing patterns (seven types).

- 6 Press the [4 (MULTI)] button once again to turn off the Multi-screen effect.

The [4 (MULTI)] button will go out.



- For each bus, you can use up to four effects simultaneously. However, there are some combinations of effects that cannot be used simultaneously. For details, refer to “Effects that Cannot Be Used Simultaneously” (p. 107).
- You can change the direction in which the screen is divided, and the effect that is assigned to the [4 (MULTI)] button. For details, refer to “Assigning Different Effects to the EFFECTS Buttons” (p. 53).

Inverting the Image (Flip)

You can invert the image between top/bottom, left/right, or top/bottom/left/right.

- 1 Set the [MEMORY] knob to memory number 1.

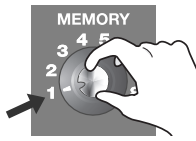

* The factory preset settings are assigned to memory number 1. For details on the [MEMORY] knob, refer to “Storing the Operating Panel Settings” (p. 28).

- 2 Press a bus B INPUT SELECT button to select an image.
- 3 Move the video fader to the bus B position to output the bus B image.
- 4 Press the bus B EFFECTS [1 (FLIP)] button to turn the Flip effect on.

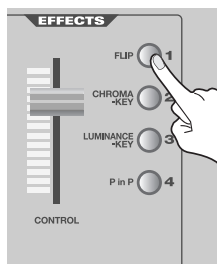

The [1 (FLIP)] button will blink, and the bus B output image will be flipped.

- 5 Operate the bus B [CONTROL] fader to change the direction of the flip.

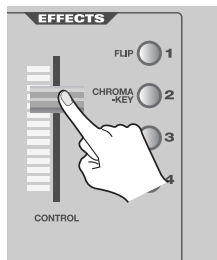

* The blinking of the [1 (FLIP)] button indicates that you can use the [CONTROL] fader to switch between different directions (three choices) for the Flip effect.

- 6 Press the [1 (FLIP)] button once again to turn off the Flip effect.

The [1 (FLIP)] button will go out.



- For each bus, you can use up to four effects simultaneously. However, there are some combinations of effects that cannot be used simultaneously. For details, refer to “Effects that Cannot Be Used Simultaneously” (p. 107).
- You can change the direction in which the image is flipped, and the effect that is assigned to the [1 (FLIP)] button. For details, refer to “Assigning Different Effects to the EFFECTS Buttons” (p. 53).

Assigning Different Effects to the EFFECTS Buttons

You can change the effects that are assigned to the EFFECTS buttons.

- 1 Turn the [MEMORY] knob to select the memory number 2–8 whose settings you want to edit.

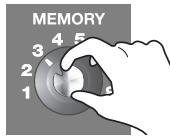

* Memory number 1 contains the factory preset settings (p. 28). These settings cannot be modified.

- 2 Press the [MENU] button to access the menu, and choose “Effects-A” or “Effects-B.”



- 1 Press the [MENU] button to access the menu.
- 2 Use the [▲][▼] buttons to select “Effects-A” or “Effects-B.”
Select the menu item for the button whose assignment you want to change.

Button	Menu item
Bus A EFFECTS buttons	Effects-A
Bus B EFFECTS buttons	Effects-B

- 3 Press the [ENTER] button to confirm your selection.

- 3 Use the [▲][▼] buttons to select the menu item for the button whose assignment you want to change.



- 1 Press the [MENU] button to access the menu, and choose “A-Efx1”–“A-Efx4” or “B-Efx1”–“B-Efx4”
Select the menu item for the button whose assignment you want to change.

● If you’ve selected bus A

Button	Menu item
[1 (FEEDBACK)] button	A-Efx1
[2 (NEGATIVE)] button	A-Efx2
[3 (COLORIZE)] button	A-Efx3
[4 (MULTI)] button	A-Efx4

● If you’ve selected bus B

Button	Menu item
[1 (FLIP)] button	B-Efx1
[2 (CHROMA KEY)] button	B-Efx2
[3 (LUMINANCE KEY)] button	B-Efx3
[4 (P in P)] button	B-Efx4

- 2 Press the [ENTER] button to confirm your selection.

- 4 Use the [▲][▼] buttons to specify to the desired effect type.

If you press the corresponding EFFECTS button so it’s lit or blinking, and then operate the video fader, you’ll be able to see the currently selected effect applied to the output image.

For details on effects, refer to “Effect List” (p. 105).

- 5 Press the [MENU] button several times to close the menu.

Editing the Input/Output Settings

Adjusting the Input Image

Adjusting the PC Input Image

Here's how to make adjustments such as the brightness, color, and position of the image being input to the PC connectors.

- 1 Use the [PC INPUT SELECT] switch to select either the PC1 input or PC2 input.

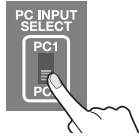

- * Input image adjustments can be made individually for the PC1 input and PC2 input.
- * When you use the [PC INPUT SELECT] switch to switch the PC input, it will take some time for the input to stabilize. We recommend that you use a monitor to verify the image.

- 2 Press the [MENU] button to access the menu, and choose "PC Input Setup."

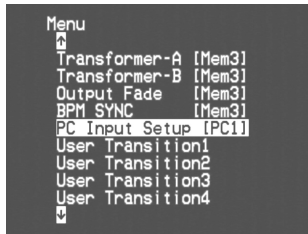

- ① Press the [MENU] button to access the menu.
- ② Use the [▲][▼] buttons to select "PC Input Setup."
- ③ Press the [ENTER] button to confirm your selection.

- 3 Referring to the table below, use the [▲][▼] buttons to select the item you want to edit, and press the [ENTER] button.

Menu item	Details
Hposition	Adjusts the display position in the horizontal direction.
Vposition	Adjusts the display position in the vertical direction.
Hsize	Adjusts the size in the horizontal direction.
Vsize	Adjusts the size in the vertical direction.
Contrast	Adjusts the contrast of the image.
Brightness	Adjusts the brightness of the image.
Sharpness	Adjusts the sharpness of the outline.
Flick Filter	Adjusts the flickering of the image.
Color	Adjusts the color of the image.
Zoom	Turns magnification of the image on/off. Turn this "On" to magnify the image.
Auto Detect	Turns the Auto Detect function (automatic detection of input resolution) on/off. (p. 55)
PC Preset	Returns the sub-menu settings to the factory-set state (p. 34).

- 4 Use the [▲][▼] buttons to edit the value.
- 5 Press the [MENU] button several times to close the menu.

About the input resolution

The V-8 supports the following resolutions.

Resolutions	640 x 480	800 x 600	832 x 624 *1	1024 x 768
Maximum refresh rate	120 Hz	120 Hz	75 Hz	80 Hz
Resolutions	1152 x 864	1152 x 870 *1	1280 x 1024	1600 x 1200
Maximum refresh rate	80 Hz	75 Hz	75 Hz	60 Hz

*1 This is a resolution for the Macintosh. Other resolutions are common to both Windows and Macintosh.

* Depending on the resolution of your computer, text may be difficult to read. In this case, lower the resolution.

Automatically detecting the input resolution (Auto Detect)

With the factory settings, the Auto Detect function, which automatically detects the input resolution, is turned “On.” Normally, you can leave Auto Detect turned “On.”

If, as shown in figure 1, the background color of the computer screen is black and an image is being displayed in a portion of the screen, the resolution may not be detected correctly. In this case, take the following steps.

- ① **Set a window, etc. on the computer to full screen mode (figure 2).**
After a brief interval, the input resolution will be automatically detected, and the output image will be resized.
- ② **In the “PC Input Setup” menu, turn the “Auto Detect” setting “Off.”**
Automatic detection of the input resolution will be turned off.
- ③ **Display the original image (figure 1).**

figure 1



figure 2

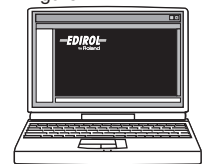

Skewed or Flickering Images (Tearing)

When moving images from a PC input are displayed, skewed or flickering images may occur. This is called “tearing,” and is caused by discrepancies in the timing at which the images are rendered, so that a portion of the previous frame is shown simultaneously with the next frame.

The illustration below is a conceptual example of tearing.

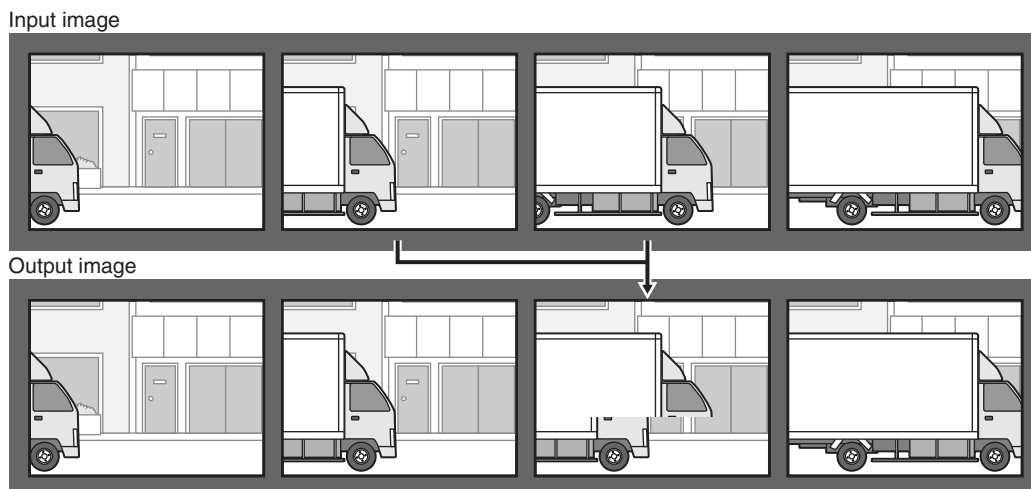

* If the “STILL” or “STROBE” effects are used on moving images input from a PC, a state in which tearing has occurred may be frozen.

Adjusting the Input Image for Bus A and B

Here's how to adjust the brightness and color of the image that's being input to bus A and bus B.

1 Press the [MENU] button to access the menu, and choose "Utility."

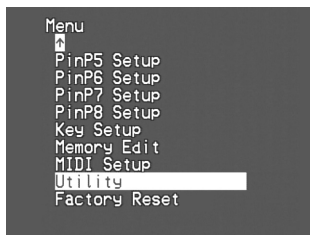

- ① Press the [MENU] button to access the menu.
- ② Use the [▲] [▼] buttons to select "Utility."
- ③ Press the [ENTER] button to confirm your selection.

2 Referring to the table below, use the [▲] [▼] buttons to select the menu item that you want to edit, and press the [ENTER] button.

Menu item	Content
VideoA Bright Adjust	Adjusts the brightness of the image being input to bus A.
VideoA Color Adjust	Adjusts the color of the image being input to bus A.
VideoA Hue Adjust	Adjusts the hue of the image being input to bus A.
VideoB Bright Adjust	Adjusts the brightness of the image being input to bus B.
VideoB Color Adjust	Adjusts the color of the image being input to bus B.
VideoB Hue Adjust	Adjusts the hue of the image being input to bus B.

3 Use the [▲] [▼] buttons to edit the value.

4 Press the [MENU] button several times to close the menu.



The PC1 and PC2 input images are affected by the individual settings for each PC input (p. 54) in addition to the image adjustments for bus A and bus B.

If the image is distorted

In some cases, the image may be distorted when synchronization cannot be achieved correctly because the level of the synchronization signal being output from your video device is lower than the normal level. In such cases, try adjusting the "Utility" menu item "Video Sync Threshold." This may allow synchronization to be achieved so that the image will display properly.

Adjusting the Output Image

Here's how to adjust the image that's being output from the V-8.

- 1 Press the [MENU] button to access the menu, and choose "Utility."



- 1 Press the [MENU] button to access the menu.
- 2 Use the [▲] [▼] buttons to select "Utility."
- 3 Press the [ENTER] button to confirm your selection.

- 2 Referring to the table below, use the [▲] [▼] buttons to select the menu item that you want to adjust, and press the [ENTER] button.

Menu item	Explanation
Video Display Range H	Adjusts the horizontal size of the final output image.
Video Display Range V	Adjusts the vertical size of the final output image.
Video Out Black Level	Adjusts the black level reference (setup level) of the output signal. PAL and Japanese NTSC use the "0 IRE" setting, and United States NTSC uses the "7.5 IRE" setting.

- 3 Use the [▲] [▼] buttons to edit the value.
- 4 Press the [MENU] button several times to close the menu.

Outputting Color Bars

Here's how to display color bars as a convenience when adjusting your display.

- 1 Press the [MENU] button to access the menu, and choose "Utility."



- 1 Press the [MENU] button to access the menu.
- 2 Use the [▲] [▼] buttons to select "Utility."
- 3 Press the [ENTER] button to confirm your selection.

- 2 Use the [▲] [▼] buttons to choose "Color Bar Out," and press the [ENTER] button.

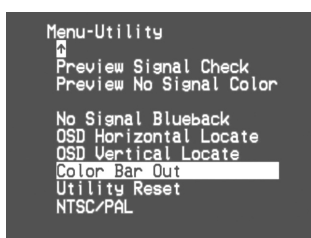

- 3 Use the [▲] [▼] buttons to choose "On."

Color bars will be output.

Value	Details
On	Color bars will be output.
Off	Color bars will not be output.

- 4 Press the [MENU] button several times to close the menu.

Switching Between NTSC and PAL

The V-8's input/output format can be switched between the NTSC format used in Japan and the United States, and the PAL format used in Europe. Choose the setting that's appropriate for your situation.

- 1 Press the [MENU] button to access the menu, and choose "Utility."



- 1 Press the [MENU] button to access the menu.
- 2 Use the [▲][▼] buttons to select "Utility."
- 3 Press the [ENTER] button to confirm your selection.

- 2 Use the [▲][▼] buttons to select "NTSC/PAL," and press the [ENTER] button.

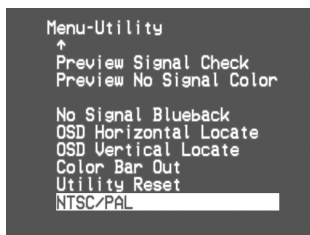

- 3 Use the [▲][▼] buttons to choose "NTSC" or "PAL."

The input/output format will change.

- 4 Press the [MENU] button several times to close the menu.



When the V-8 starts up, the preview monitor will indicate the input/output format setting (NTSC or PAL) for several seconds. The BPM display will also indicate either "NTSC" (NTSC) or "PAL" depending on the input/output setting.

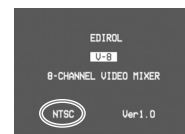

Switching Between NTSC and PAL at Startup

You can also switch between NTSC and PAL when the V-8 starts up.

- 1 While holding down the PREVIEW OUT SELECT [1] button and [OUTPUT] button, turn on the power.

The V-8 will start up with the input/output format switched.

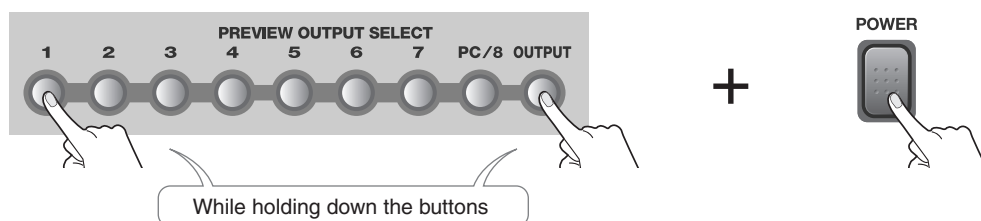

Switching Images in Synchronization with Music (BPM Sync)

You can make images switch in synchronization with the beat of music. This causes the images to switch automatically without your having to operate the video fader or the [TRANSFORMER] buttons.

You can specify the switching timing as a specified BPM (Beats Per Minute) or as the interval at which you press the [TAP] button.

Switching Images at a Specified BPM

Here's how to specify a BPM (Beats Per Minute) setting at which the image will change each beat.

1 Set the [MEMORY] knob to memory number 1.

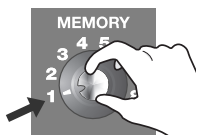

* The factory preset settings are assigned to memory number 1. For details on the [MEMORY] knob, refer to “Storing the Operating Panel Settings” (p. 28).

2 Use the bus A and bus B INPUT SELECT buttons to select the desired input images.

Input different images to bus A and bus B.

3 Turn the [BPM/CONTROL] knob to specify the BPM.

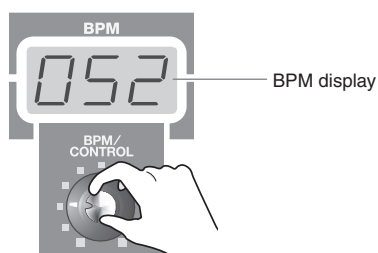

The current BPM is shown in the BPM display.

Decreasing the BPM value will slow down the timing at which the images change. Increasing the BPM value will speed up the timing at which the images will change. You can adjust the BPM in a range of 20–240.

* If you've selected “003: Fam*” or “005: Nam*” as the transition effect applied by a TRANSITION button, the FAM/NAM cross point level (p. 37) will blink in the BPM display. Turning the [BPM/CONTROL] knob will adjust the cross point level. If you want to change the BPM, use the [TAP] button (p. 61).

4 Press the [BPM SYNC] button.

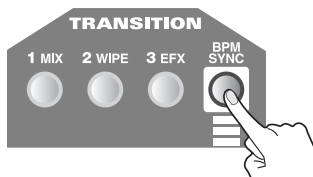

The [BPM SYNC] button will light, and the images will switch automatically at the specified BPM. If you want to change the timing at which the images switch, turn the [BPM/CONTROL] knob to adjust the BPM value.

The transition effect selected by the TRANSITION buttons will be applied when the images are switched.



- You can use BPM Sync to turn an effect on/off in synchronization with the beat of the music. In this case, input the same image to bus A and bus B, and then apply the effect. The effect will switch on/off at the timing that the image switches between bus A and bus B.
- When using BPM Sync, you can make the transition effect be a cut, or make the transition occur at a multiple of the displayed BPM interval. For details, refer to “Changing the Settings of the [BPM SYNC] Button” (p. 62).
- If you use BPM Sync or the [TRANSFORMER] buttons (p. 40) to switch images automatically, there will be situations in which the position of the video fader will not match the actual output. If you set the “Utility” menu item “Video Fader Mode” to “Quick,” the output will change to match the fader position when you move the video fader slightly (p. 78).

Switching Images at the Tempo Specified by the [TAP] Button

Here's how to specify the BPM by pressing the [TAP] button at the desired interval, causing the image to switch at each beat.

1 Set the [MEMORY] knob to memory number 1.

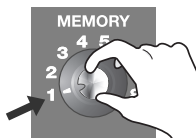

* The factory preset settings are assigned to memory number 1. For details on the [MEMORY] knob, refer to “Storing the Operating Panel Settings” (p. 28).

2 Use the bus A and bus B INPUT SELECT buttons to select the desired input images.

Input different images to bus A and bus B.

3 Press the [BPM SYNC] button.

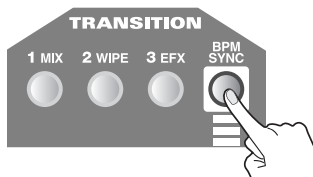

The [BPM SYNC] button will light, and the images will automatically switch at the BPM shown in the BPM display. The transition effect selected by the TRANSITION buttons will be applied when the images are switched.

4 Press the [TAP] button to specify the BPM.

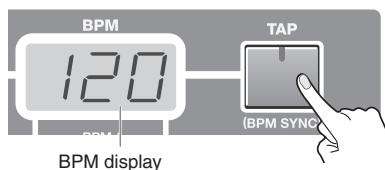

The current BPM is shown in the BPM display.

Repeatedly press the [TAP] button in time with the beat of the background music you're using. The BPM indication will change continuously according to the timing at which you press the [TAP] button. The image will switch according to the displayed BPM.

* If you've selected “003: Fam*” or “005: Nam*” as the transition effect applied by a TRANSITION button, the FAM/NAM cross point level (p. 37) will blink in the BPM display. To check the BPM setting, set the “Utility” menu item “Preview Display Mode” to the “Mode3” setting, and note the settings data shown in the preview monitor (p. 26–27).



- When using BPM Sync, you can make the transition effect be a cut, or make the transition occur at a multiple of the displayed BPM interval. For details, refer to “Changing the Settings of the [BPM SYNC] Button” (p. 62).
- If you use BPM Sync or the [TRANSFORMER] buttons (p. 40) to switch images automatically, there will be situations in which the position of the video fader will not match the actual output. If you set the “Utility” menu item “Video Fader Mode” to “Quick,” the output will change to match the fader position when you move the video fader slightly (p. 78).

Changing the Settings of the [BPM SYNC] Button

When using BPM Sync to switch images, you can make the transition effect be a cut, or make the transition occur at a multiple of the displayed BPM interval.

- 1 Turn the [MEMORY] knob to select the memory number 2–8 that you want to edit.



* Memory number 1 contains the factory preset settings (p. 28). These settings cannot be modified.

- 2 Press the [MENU] button to access the menu, and choose “BPM SYNC.”

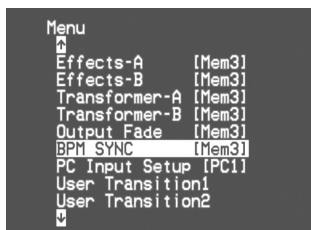

- ① Press the [MENU] button to access the menu.
- ② Use the [▲][▼] buttons to select “BPM SYNC.”
- ③ Press the [ENTER] button to confirm your selection.

- 3 Specify the image switching mode.



- ① Use the [▲][▼] buttons to select “Mode,” and press [ENTER].
- ② Use the [▲][▼] buttons to specify what will happen when images are switched.

Value	Details
DirectA/B	Cut between the bus A and bus B images.
TransitionA/B	Apply the transition effect selected by the TRANSITION buttons when switching between the bus A and bus B images.

- 4 Specify a multiple of the displayed BPM as the switching interval.



- ① Press the [MENU] button to return to the previous screen.
- ② Use the [▲][▼] buttons to select “Speed,” and press [ENTER].
- ③ Use the [▲][▼] buttons to select the multiple or fraction of the displayed BPM at which the image will switch.

Value	Details
BPMx1/4	Switches the image at 1/4th the speed of the displayed BPM.
BPMx1/2	Switches the image at 1/2 the speed of the displayed BPM.
BPMx1	Switches the image at the same speed as the displayed BPM.
BPMx2	Switches the image at double the speed of the displayed BPM.

- 5 Press the [MENU] button several times to close the menu.

Using the V-8 with Other Equipment

Using MIDI to Control the V-8 from an External Device

About MIDI

What is MIDI?

MIDI, an abbreviation for Musical Instrument Digital Interface, is an international standard created to enable exchange of performance data among devices. Any MIDI-compatible device can be connected simply with a MIDI cable, allowing transfer of performance data and control of device operations and settings.

MIDI Connectors

MIDI messages (data handled with MIDI). On the V-8, the MIDI OUT and MIDI THRU are combined in one connector. The function is switched according to the operation being performed (p. 66).

MIDI IN: MIDI messages from other MIDI devices are received here.

MIDI OUT: MIDI messages from the V-8 are transmitted from here.

MIDI THRU: MIDI messages received at the MIDI IN connector are output as is.

MIDI channels

MIDI allows you to transmit multiple streams of data to connected MIDI devices via a single MIDI cable. This is made possible by the concept of MIDI channels. You can think of MIDI channels as being somewhat similar in function to the channels on a television. By changing the channel of a TV set, you can view a variety of programs being transmitted by different broadcast stations. This is because data is received only from the transmitter whose channel is selected on the receiver.

In the same way, a MIDI device whose receive channel is set to "1" will receive only the data being transmitted by another MIDI device whose transmit channel is also set to "1."

MIDI Implementation Chart

The use of MIDI makes it possible to communicate with a broad range of electronic musical instruments. However, this does not mean that all MIDI messages can be exchanged among all devices. Only those MIDI messages that both of the communicating devices are designed to understand can be exchanged. The owner's manual that comes with a MIDI device includes a MIDI Implementation Chart (p. 98).

Such charts allow you to easily find out which MIDI messages that device can transmit and receive. When using MIDI devices, compare the charts for the devices that will be communicating to check which MIDI messages are compatible.

Buttons and Knobs that Transmit or Receive MIDI Messages

Operations of the V-8's buttons and knobs can be transmitted as MIDI messages. Conversely, MIDI messages received from an external device can control the settings of the V-8's buttons and knobs.

* For details on MIDI messages, refer to "MIDI Implementation" (p. 90).

Buttons and knobs that transmit or receive MIDI messages

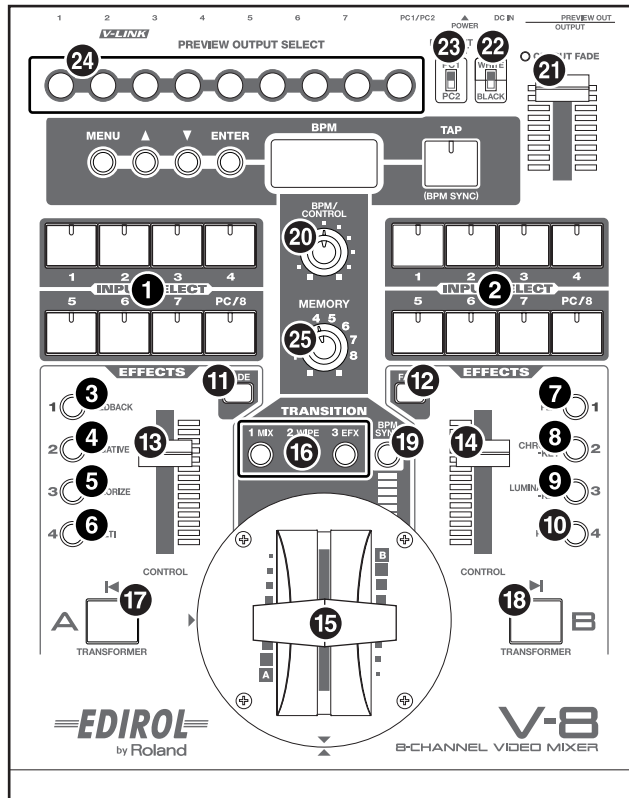

- | | |
|------------------------------|---------------------------------|
| ① Bus A INPUT SELECT buttons | ⑭ Bus B [CONTROL] fader *1 |
| ② Bus B INPUT SELECT buttons | ⑮ Video fader |
| ③ [1 (FEEDBACK)] button | ⑯ TRANSITION buttons |
| ④ [2 (NEGATIVE)] button | ⑰ Bus A [TRANSFORMER] button |
| ⑤ [3 (COLORIZE)] button | ⑱ Bus B [TRANSFORMER] button |
| ⑥ [4 (MULTI)] button | ⑲ [BPM SYNC] button |
| ⑦ [1 (FLIP)] button | ⑳ [BPM/CONTROL] knob *1 |
| ⑧ [2 (CHROMA KEY)] button | ㉑ [OUTPUT FADE] fader |
| ⑨ [3 (LUMINANCE KEY)] button | ㉒ [WHITE/BLACK] switch |
| ⑩ [4 (P in P)] button | ㉓ [PC INPUT SELECT] switch |
| ⑪ Bus A [FADE] button | ㉔ PREVIEW OUTPUT SELECT buttons |
| ⑫ Bus B [FADE] button | ㉕ [MEMORY] knob |
| ⑬ Bus A [CONTROL] fader *1 | |

*1 Transmit only.

Specifying the MIDI message assigned to a button or knob

- 1** Press the [MENU] button to access the menu, and choose “MIDI Setup.”



- ① Press the [MENU] button to access the menu.
- ② Use the [▲] [▼] buttons to select “MIDI Setup.”
- ③ Press the [ENTER] button to confirm your selection.

- 2** Referring to the table below, use the [▲] [▼] buttons to select the item you want to edit, and press the [ENTER] button.

Menu item	Details
Input Select A Assign	Bus A INPUT SELECT buttons
Input Select B Assign	Bus B INPUT SELECT buttons
Effects-A1 Assign	[1 (FEEDBACK)] button
Effects-A2 Assign	[2 (NEGATIVE)] button
Effects-A3 Assign	[3 (COLORIZE)] button
Effects-A4 Assign	[4 (MULTI)] button
Effects-B1 Assign	[1 (FLIP)] button
Effects-B2 Assign	[2 (CHROMA KEY)] button
Effects-B3 Assign	[3 (LUMINANCE KEY)] button
Effects-B4 Assign	[4 (P in P)] button
Fade A Switch Assign	Bus A [FADE] button
Fade B Switch Assign	Bus B [FADE] button
Control A Assign	Bus A [CONTROL] fader
Control B Assign	Bus B [CONTROL] fader
Video Fader Assign	Video fader
Transition Assign	TRANSITION buttons
Transformer A Assign	Bus A [TRANSFORMER] button
Transformer B Assign	Bus B [TRANSFORMER] button
BPM SYNC Assign	[BPM SYNC] button
Transition Time Assign	Image switching time in PR Control mode (p. 75)
BPM/CONTROL Assign	[BPM/CONTROL] knob
Output Fade Assign	[OUTPUT FADE] fader
White/Black Assign	[WHITE/BLACK] switch
PC Input Select Assign	[PC INPUT SELECT] switch
Preview Output Assign	PREVIEW OUTPUT SELECT buttons
Memory Assign	[MEMORY] knob

- 3** Using the [▲] [▼] buttons to change the value, specify the MIDI message that you want to assign to the button or knob.

Assign the MIDI messages so that they match the MIDI messages that are transmitted/received by the MIDI device you've connected.

Example) When you want to control video fader operations using the fader of your MIDI controller

Assign “Video Fader Assign” to the same MIDI message that is transmitted when you operate the fader of your MIDI controller.

- 4** Press the [MENU] button several times to close the men

MIDI Message Transmission Settings

Specifying the MIDI message transmit channel

Here's how to specify the channel on which MIDI messages will be transmitted.

- 1 Press the [MENU] button to access the menu, and choose "MIDI Setup."



- ① Press the [MENU] button to access the menu.
- ② Use the [▲] [▼] buttons to select "MIDI Setup."
- ③ Press the [ENTER] button to confirm your selection.

- 2 Use the [▲] [▼] buttons to choose "MIDI Tx Channel," and press the [ENTER] button.



- 3 Use the [▲] [▼] buttons to specify the transmit channel.
- 4 Press the [MENU] button several times to close the menu.

MIDI OUT/THRU connector setting

Here's how to specify whether you want to use the MIDI OUT connector as MIDI OUT or as MIDI THRU. If you want to transmit MIDI messages, set the connector to function as a MIDI OUT.

- 1 Press the [MENU] button to access the menu, and choose "MIDI Setup."
- 2 Use the [▲] [▼] buttons to choose "MIDI Out/Thru Switch," and press the [ENTER] button.



- 3 Use the [▲] [▼] buttons to specify the function of the MIDI OUT/THRU connector.

Value	Details
Out	The MIDI OUT connector will function as a MIDI OUT.
Thru	The MIDI OUT connector will function as a MIDI THRU. MIDI messages received at the MIDI IN connector will be retransmitted without change.

- 4 Press the [MENU] button several times to close the menu.

Turning MIDI message transmission on/off (Panel mode)

Here's how to specify whether MIDI messages will be transmitted when you operate the V-8's buttons and knobs.

- 1 Turn the [MEMORY] knob to select the memory number 2–8 that you want to edit.

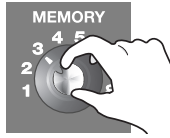

* Memory number 1 contains the factory preset settings (p. 28). These settings cannot be modified.

- 2 Press the [MENU] button to access the menu, and choose “MIDI Setup.”

- 3 Use the [▲] [▼] buttons to choose “Panel Mode,” and press the [ENTER] button.

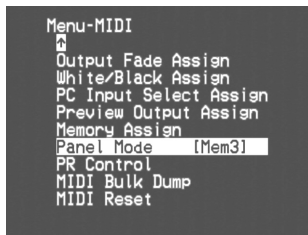

- 4 Use the [▲] [▼] buttons to select “Video+MidiOut” or “Midi Out Only.”

Value	Details
Video+MidiOut	Video signals and MIDI messages will be output.
Video Only	Only video signals will be output.
Midi Out Only	Only MIDI messages will be output (Local Off). If the “Midi Out Only” setting is selected, the following buttons and knobs can be operated. The other buttons and knobs will not do anything. If you press a button that does nothing, it will not light. [MENU] button, [▲] button, [▼] button, [ENTER] button, [TAP] button, [BPM/CONTROL] knob, [MEMORY] knob, PREVIEW OUTPUT SELECT buttons, [PC INPUT SELECT] switch, [WHITE/BLACK] switch

- 5 Press the [MENU] button several times to close the menu.

MIDI Message Reception Settings

Specifying the MIDI message receive channel

Here's how to specify the channel on which MIDI messages will be received.

- 1 Press the [MENU] button to access the menu, and choose "MIDI Setup."



- 1 Press the [MENU] button to access the menu.
- 2 Use the [▲] [▼] buttons to select "MIDI Setup."
- 3 Press the [ENTER] button to confirm your selection.

- 2 Use the [▲] [▼] buttons to choose "MIDI Rx Channel," and press the [ENTER] button.



- 3 Use the [▲] [▼] buttons to specify the receive channel.
- 4 Press the [MENU] button several times to close the menu.

Turning note message reception on/off

Here's how to specify whether note messages from a MIDI keyboard or other device will be received.

- 1 Press the [MENU] button to access the menu, and choose "MIDI Setup."
- 2 Use the [▲] [▼] buttons to choose "Note Mode," and press the [ENTER] button.



- 3 Use the [▲] [▼] buttons to choose "49Keys Mode" or "Assign Mode."

Value	Details
Off	Note messages will not be received.
49Keys Mode	INPUT SELECT 1–8 will be assigned to the white keys of the keyboard (C2–D4).
Assign Mode	INPUT SELECT 1–8 will be assigned to all keys of the keyboard. You can specify the note range by setting the "MIDI Setup" menu items "Note Lower Key Assign" (lowest note) and "Note Upper Key Assign" (highest note).

- 4 Press the [MENU] button several times to close the menu.

Saving V-8 Settings on an External MIDI Device (Bulk Dump)

Transmitting Menu Setting Data to an External MIDI Device

You can transmit the V-8's settings data to an external MIDI device (such as MIDI sequencer software) as MIDI data for storage.

- * Make sure that the V-8 and your MIDI device are set to the same device ID. The V-8's device ID is specified by the "MIDI Setup" menu item "Device ID."
- * Set the "MIDI Setup" menu item "MIDI Out/Thru Switch" so that the V-8's MIDI OUT/THRU connector is functioning as an "Out."

1 Connect the V-8's MIDI OUT/THRU connector to the MIDI IN connector of your MIDI device.

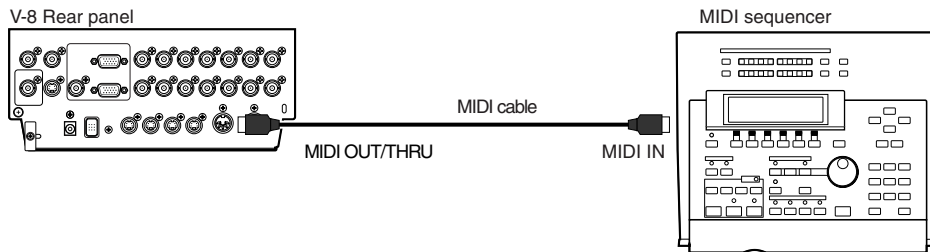

2 Operate your external MIDI device so that it will be ready to receive MIDI data.

3 Press the [MENU] button to access the menu, and choose "MIDI Setup."



- ① Press the [MENU] button to access the menu.
- ② Use the [▲] [▼] buttons to select "MIDI Setup."
- ③ Press the [ENTER] button to confirm your selection.

4 Use the [▲] [▼] buttons to choose "MIDI Bulk Dump," and press the [ENTER] button.



5 Begin recording on your external MIDI device.

6 Use the [▲] [▼] buttons to choose "Yes [ENTER] Sw," and press the [ENTER] button.

(If you decide to cancel, press the [MENU] button or choose "No" and press the [ENTER] button.)

The MIDI data will be transmitted from the V-8.

7 Stop recording on your external MIDI device.

8 Press the [MENU] button several times to close the menu.

Restoring Data Saved on an External MIDI Device Back into the V-8

Here's how settings saved on an external MIDI device can be restored back into the V-8.

- * Make sure that the V-8 and your MIDI device are set to the same device ID. The V-8's device ID is specified by the "MIDI Setup" menu item "Device ID."

1 Connect the V-8's MIDI IN connector to the MIDI OUT connector of your external MIDI device.

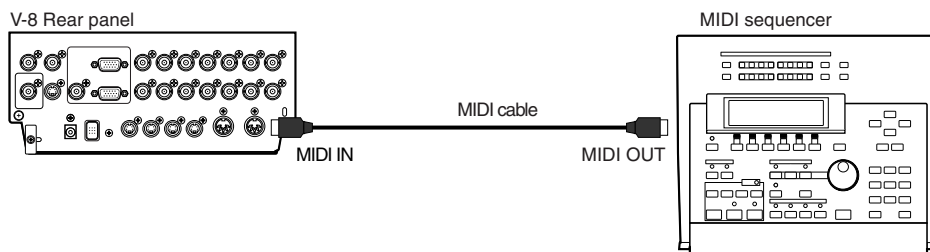

2 Begin playback on your external MIDI device.

The MIDI data will be sent from the transmitting MIDI device. When the V-8 receives the MIDI data, the existing settings will be overwritten.

3 Stop playback on your external MIDI device.

Sending the V-8's Settings to Another V-8

By sending the V-8's parameter settings to another V-8 unit as MIDI data, you can put the settings of both V-8 units in the same condition.

- * Make sure that the transmitting V-8 and the receiving V-8 are set to the same device ID. The device ID is specified by the "MIDI Setup" menu item "Device ID."
- * Set the "MIDI Setup" menu item "MIDI Out/Thru Switch" so that the transmitting V-8's MIDI OUT/THRU connector is functioning as "Out."

* About the receiving V-8

Settings are overwritten when MIDI data is received, meaning that the previous settings will be lost. If you want to keep the settings, back them up from the V-8 to an external MIDI device (p. 69).

1 Connect the transmitting V-8's MIDI OUT/THRU connector to the receiving V-8's MIDI IN connector.

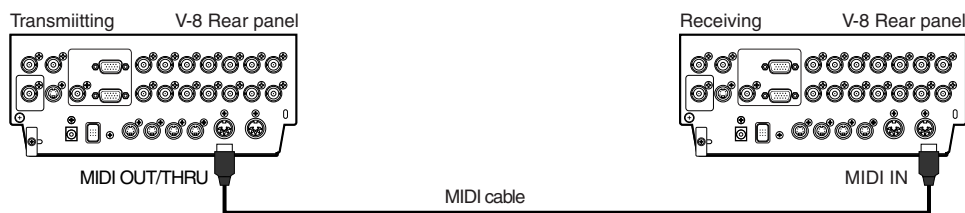

2 Press the [MENU] button to access the menu, and choose "MIDI Setup."



- ① Press the [MENU] button to access the menu.
- ② Use the [▲][▼] buttons to select "MIDI Setup."
- ③ Press the [ENTER] button to confirm your selection.

3 Use the [▲][▼] buttons to choose "MIDI Bulk Dump," and press the [ENTER] button.



4 Use the [▲][▼] buttons to choose "Yes [ENTER] Sw," and press the [ENTER] button. (If you decide to cancel, press the [MENU] button or choose "No" and press the [ENTER] button.)

MIDI data will be sent from the transmitting V-8. When the receiving V-8 receives the MIDI data, its settings will be overwritten.

5 Press the [MENU] button several times to close the menu.

Controlling via V-LINK

What is V-LINK?

V-LINK (**V-LINK**) is a function that allows music and images to be performed together. By using MIDI to connect two or more V-LINK compatible devices, you can easily enjoy performing a wide range of visual effects that are linked to the expressive elements of a music performance.

For example, when using the V-8 in conjunction with the RSS M-400, you can use the V-8's INPUT SELECT buttons and video fader to control the M-400's audio input level.

When using the V-8 in conjunction with the Roland Fantom-X, you can control the V-8's video output or video switching in time with the performance on the Fantom-X.

Controlling the RSS M-400 from the V-8 (V-LINK Master)

V-LINK function chart

When V-LINK mode is on (p. 73), you can control the M-400's audio input levels from the V-8.

* Up to eight of the M-400's input channels can be controlled from the V-8.

V-LINK function	V-8 operation
To select an input channel	Press an INPUT SELECT button.
To adjust an audio input level	Operate the video fader.

Connections

Connect the V-8 and the M-400 as shown in the illustration below.

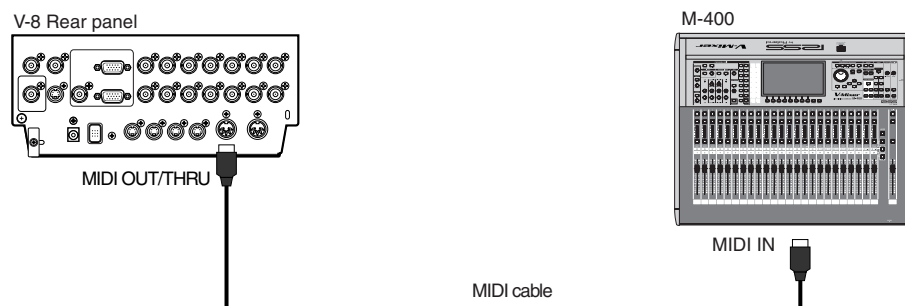

Controlling the V-8 from an External V-LINK Compatible Device (V-LINK Slave)

You can turn V-LINK mode on from a V-LINK compatible device connected to the V-8. When V-LINK mode is turned on, the V-8 can be controlled from the external device to switch the video output or image.

- * Power up the V-8, and then turn V-LINK mode on.

1 Connect your V-LINK compatible external device to the V-8

Use a MIDI cable to connect your external device's MIDI OUT connector to the V-8's MIDI IN connector.

2 Press the external device's [V-LINK] button.

The external device will transmit a V-LINK ON message.

The V-8 will now be able to accept control from the external device, and switch the video output or image.

When V-LINK mode is turned on, the preview monitor (p. 26) will indicate "V-LINK."



- Also refer to the owner's manual of the V-LINK compatible device you've connected to the V-8.
- For details on the functions that can be controlled from an external device in V-LINK mode, refer to the MIDI implementation of the connected device and the MIDI implementation of the V-8. The functions that can be controlled will depend on the connected device and on the settings.

Using the V-8 in Conjunction with the PR Series (PR Control mode)

By switching the V-8's operating mode to "PR Control mode," you'll be able to control the V-8 from an Edirol PR-80/50 (subsequently referred to as the PR series device) via MIDI.

In PR Control mode, you'll be able to perform the following operations from the PR series device.

- Switch between the image being input to the V-8 and the image of the PR series simply by operating the PR series device.
- Use the Scheduler function of the PR series unit to operate the V-8 automatically.

NOTE Use version 1.2 or later for the PR series.

Connection example

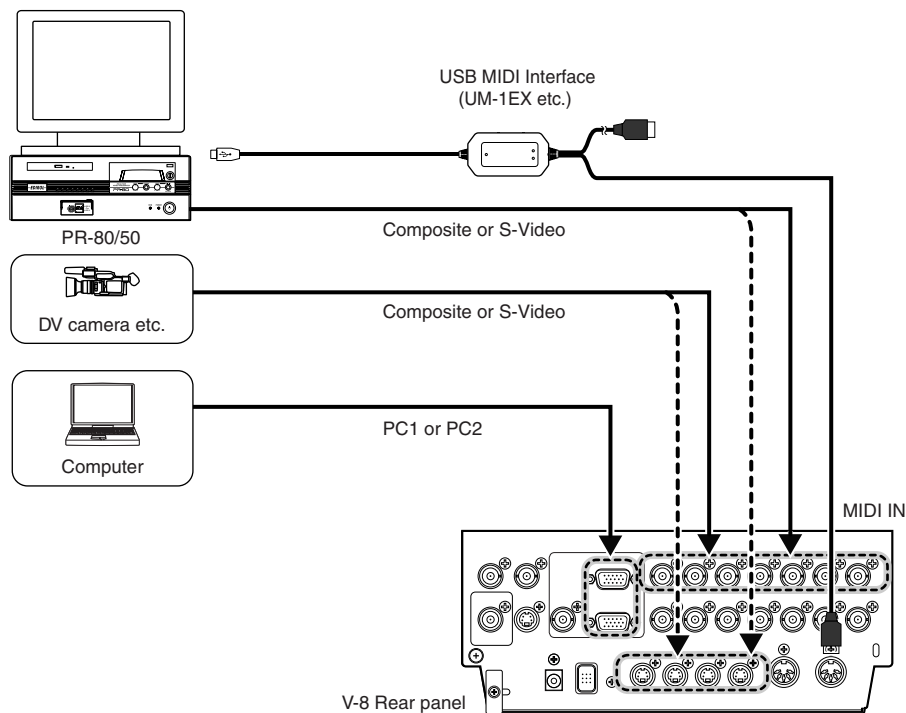

Switching to PR Control mode

* For details on settings and operation for the PR series, refer to the PR series owner's manual.

- 1 Press the [MENU] button to access the menu, and select "MIDI Setup."
- 2 Use the [▲] [▼] buttons to select "PR Control," and press the [ENTER] button.





- 3 Use the [▲] [▼] buttons to select "On."
When this is "On," you'll be able to control the V-8 from the PR series unit.
- 4 Press the [MENU] button several times to close the menu.

Adjusting the Video Fader

Installing the Video Fader in the Most Convenient Orientation

The V-8's video fader can be installed either in a vertical orientation or a horizontal orientation.

-  Always turn the unit off and unplug the AC adaptor before attempting installation of the video fader.
-  For installation of the video fader, remove only the specified screws.

- 1** Switch off the V-8's power.
- 2** Use a Phillips screwdriver to remove the four screws shown in the illustration.

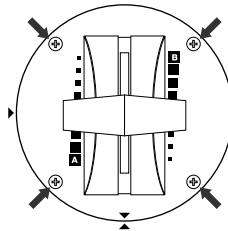

- 3** Change the orientation of the video fader.

Align the triangular symbol printed on the video fader panel (circular) with the triangular symbol printed on the V-8's panel.

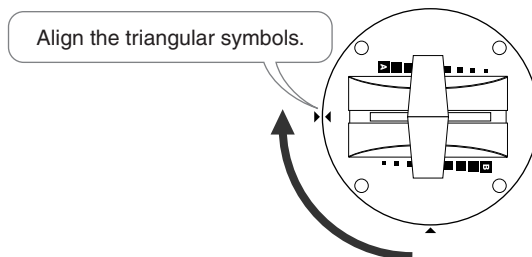

NOTE

When changing the orientation of the video fader, do not pull the video fader upward or rotate it more than 90 degrees. Doing so may disconnect or break the cable that connects the video fader to the V-8.

- 4** Fasten the four screws that you removed in step 2.

Calibrating the Video Fader

Because of extended use or transportation, you may find that 100% of the image is not output even though you've moved the video fader all the way toward bus A or bus B. If this occurs, proceed as follows to calibrate the video fader.

* You must be sure to perform the video fader calibration after installing the V-4CF crossfader (sold separately).

1 Set the video fader to the bus A position.

First, you should perform the calibration for the bus A position.

2 Press the [MENU] button to access the menu, and choose "Utility."



- ① Press the [MENU] button to access the menu.
- ② Use the [▲] [▼] buttons to select "Utility."
- ③ Press the [ENTER] button to confirm your selection.

3 Use the [▲] [▼] buttons to select "Video Fader Calibrate A," and press the [ENTER] button.

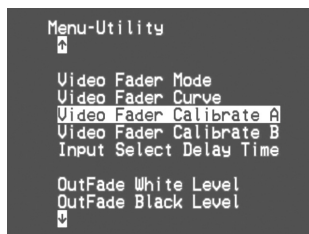

4 Make sure that the display indicates "V Fader [A] Set [ENTER] SW," and press the [ENTER] button.

Calibration will be automatically performed for the bus A position, and you will return to the previous screen.

5 Move the video fader to the bus B position.

Next, you need to perform the calibration for the bus B position.

6 Use the [▲] [▼] buttons to select "Video Fader Calibrate B," and press the [ENTER] button.

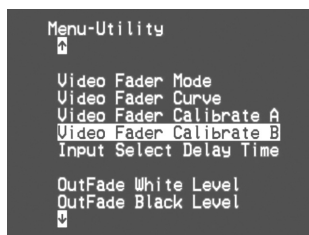

7 Make sure that the display indicates "V Fader [B] Set [ENTER] SW," and press the [ENTER] button.

Calibration will be automatically performed for the bus B position, and you will return to the previous screen.

8 Press the [MENU] button several times to close the menu.

Specifying the Video Fader Operating Curve

Here's how to select the operating curve by which the video fader will switch between images.

- 1 Press the [MENU] button to access the menu, and choose "Utility."



- 1 Press the [MENU] button to access the menu.
- 2 Use the [▲][▼] buttons to select "Utility."
- 3 Press the [ENTER] button to confirm your selection.

- 2 Use the [▲][▼] buttons to select "Video Fader Curve," and press the [ENTER] button.

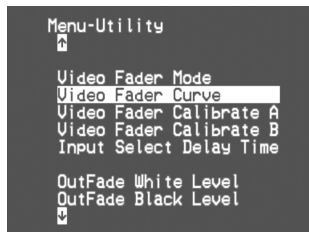

- 3 Use the [▲][▼] buttons to select the desired operating curve by which the video fader will switch between images.

Value	Details
Curve-A	
Curve-B	
Curve-C	

- 4 Press the [MENU] button several times to close the menu.

Video fader operating modes

When you use the [TRANSFORMER] buttons (p. 40) or BPM Sync (p. 60) to switch images automatically, the position of the video fader may not match the actual output. You can use the "Utility" menu item "Video Fader Mode" to specify how the video fader will act when this situation occurs.

Value	Details
Normal	The output will not change until the video fader position matches the actual output.
Quick	The actual output will immediately change to match the video fader position the instant you move the fader.





Troubleshooting

If you suspect a malfunction, please check the following points. If this does not resolve the problem, contact a nearby EDIROL/Roland Service Center.

Problems with the image output

Problem	Cause and Action
The power does not turn on when you press the [POWER] switch.	<ul style="list-style-type: none"> ● Could you be using an AC adaptor other than the included one? → Use the included AC adaptor.

Problems with the image output

Problem	Cause and Action
No image is output	<ul style="list-style-type: none"> ● Could the [OUTPUT FADE] fader be lowered? → With the factory settings, lowering the [OUTPUT FADE] fader will fade the image. Raise the [OUTPUT FADE] fader.  p. 32 ● Have you used the INPUT SELECT buttons to select an appropriate input channel? → Select a channel into which an image is being input. ● Could the [FADE] button be blinking? → If the [FADE] button is blinking, you can use the [CONTROL] fader to fade the image of bus A or bus B. Raise the [CONTROL] fader.  p. 31 ● Is an image being output from the connected video device or PC? ● Have you selected the correct input on the projector or television monitor to which the V-8's signal is being output? ● Is the correct video format (NTSC or PAL) specified? → Specify NTSC or PAL as appropriate for the format of the input signal.  p. 59
Operating the video fader does not change the image	<ul style="list-style-type: none"> ● Could the same image be selected for bus A and bus B? → If the same image is selected for bus A and bus B, operating the video fader will not change the output image. Select different images for bus A and bus B.
Image is distorted	<ul style="list-style-type: none"> ● It may be that the level of the synchronization signal being output by your video equipment is below the allowable level. → Try adjusting the "Utility" menu item "Video Sync Threshold." This may allow synchronization to be achieved so that the image will display correctly. ● Is the correct video format (NTSC or PAL) specified? → Specify NTSC or PAL as appropriate for the format of the input signal.  p. 59 ● Could you have used the [PC INPUT SELECT] switch to change PC inputs? → When you switch PC inputs, it will take some time for the input to stabilize. We recommend that you use the monitor to verify the image. ● Could you be displaying moving images from a PC input? → Displaying moving images from a PC input may cause skewed or flickering images. This is a phenomenon called "tearing," and is not a malfunction.  p. 55 ● Could you be using the INPUT SELECT buttons to switch the image? → If the video fader is not set all the way to the bus A or bus B position, using the INPUT SELECT buttons to switch channels will cause the image to be distorted, but this is not a malfunction. Before using the INPUT SELECT buttons to switch between images, perform the following operations or settings. This will allow smooth transitions between images without switching noise. <ul style="list-style-type: none"> • Set the video fader all the way to the bus A or bus B position (the bus that is outputting the image). • Raise the value of the "Utility" menu item "Input Select Delay Time."

Problems with the image output (continued)

Problem	Cause and Action
The image changes automatically	<ul style="list-style-type: none"> ● Could the [BPM SYNC] button be lit? <ul style="list-style-type: none"> → If the [BPM SYNC] button is lit, the BPM Sync function will switch images automatically. Press the [BPM SYNC] button to turn off its illumination.
Even when you set the video fader all the way to the bus A or bus B position, the output image is not 100%.	<ul style="list-style-type: none"> ● In some cases, the output image may not be 100% due to extended use or transportation. ● Could you have installed the V-4CF crossfader (sold separately)? <ul style="list-style-type: none"> → Calibrate the video fader. ☞ p. 77

Effects

Problem	Cause and Action
Operating the [CONTROL] fader does not change the effect	<ul style="list-style-type: none"> ● Have you selected an effect that has an “*” (asterisk) following the effect name? <ul style="list-style-type: none"> → The [CONTROL] fader can control effect settings only for an effect that has an “*” following the effect name. The EFFECTS button of the effect that can be controlled will blink. ☞ p. 42

Other

Problem	Cause and Action
Menu settings are not saved	<ul style="list-style-type: none"> ● Could you have switched off power before closing a menu? <ul style="list-style-type: none"> → The settings in a menu are saved in the V-8's internal memory when you close the menu. To save the settings, edit the values as desired and then close the menu before you switch off the power. ☞ p. 25
Can't change the settings in a menu	<ul style="list-style-type: none"> ● Could the [MEMORY] knob be selecting memory number 1? <ul style="list-style-type: none"> → Select a memory number from 2 through 8. Memory number 1 contains the factory preset settings. These are read-only, and cannot be edited. ☞ p. 28 ● Could memory protect be turned “On”? <ul style="list-style-type: none"> → Turn the “Utility” menu item “Memory Protect” setting “Off.” ☞ p. 25
Can't change the BPM BPM display is blinking	<ul style="list-style-type: none"> ● Could you have used the TRANSITION buttons to select the transition effect “003: Fam*” or “005: Nam*”? <ul style="list-style-type: none"> → Choose a transition effect other than “003: Fam*” or “005: Nam*.” If you've selected “003: Fam*” or “005: Nam*,” the [BPM/CONTROL] knob will change the FAM/NAM cross point. ☞ p. 37 → Use the [TAP] button to change the BPM. ☞ p. 61

Menu List

Main menu (First level)	Sub-menu (Second level)	Value	See page
1. Mix (Trans1) [Mem2]–[Mem8] *1 Specifies the transition effect assigned to the [1 MIX] button		001: Mix01, 002: Fam01, 003: Fam*, 004: Nam01, 005: Nam*, 006: Wipe01–104: Wipe99, 105: SWipe01–203: SWipe99, 204: Key01–207: Key04, 208: Slide01–233: Slide26, 234: Stretch01–259: Stretch26, 260: User01–263: User04	p. 36 p. 99
2. Wipe (Trans2) [Mem2]–[Mem8] *1 Specifies the transition effect assigned to the [2 WIPE] button			
3. Efx (Trans3) [Mem2]–[Mem8] *1 Specifies the transition effect assigned to the [3 EFX] button			
Effects-A [Mem2]–[Mem8] *1 Specifies the effects assigned to the bus A EFFECTS buttons	A-Efx1 Specifies the effect assigned to the [1 (FEEDBACK)] button	001: STILL1, 002: STILL2, 003: STROBE1–012: STROBE*, 013: AFTERIMAGE1–017: AFTERIMAGE*, 018: FEEDBACK1–022: FEEDBACK*, 023: SHAKE1*–028: SHAKE6*, 029: NOSYNC, 030: NEGATIVE1–033: NEGATIVE*, 034: COLORIZE1–042: COLORIZE*, 043: FINDEDGE1–051: FINDEDGE*, 052: SILHOUETTE1–060: SILHOUETTE*, 061: MONOCOLOR1–069: MONOCOLOR*, 070: EMBOSS1–078: EMBOSS*, 079: POSTERIZE1–083: POSTERIZE*, 084: COLORPASS1–092: COLORPASS*, 093: W-LUMIKEY, 094: W-LUMIKEY*, 095: B-LUMIKEY, 096: B-LUMIKEY*, 097: CHROMAKEY, 098: CHROMAKEY*, 099: FLIP-H, 100: FLIP-V, 101: FLIP-HV, 102: FLIP*, 103: MULTI-H1–110: MULTI-H*, 111: MULTI-V1–118: MULTI-V*, 119: MULTI-HV1–126: MULTI-HV*, 127: MIRROR-H1–131: MIRROR-H*, 132: MIRROR-V1–136: MIRROR-V*, 137: MIRROR-HV1–141: MIRROR-HV*, 142: PinP1–150: PinP*	p. 53 p. 105
	A-Efx2 Specifies the effect assigned to the [2 (NEGATIVE)] button		
	A-Efx3 Specifies the effect assigned to the [3 (COLORIZE)] button		
	A-Efx4 Specifies the effect assigned to the [4 (MULTI)] button		
Effects-B [Mem2]–[Mem8] *1 Specifies the effects assigned to the bus B EFFECTS buttons	B-Efx1 Specifies the effect assigned to the [1 (FLIP)] button	001: None, 02: Trans, 03: A<->9–12: A<->0, 13: A<-9–22: A<-0, 23: A->9–32: A->0, 33: White, 34: Black, 35: MIX, 36: WIPE, 37: EFX, 38: EFXA1, 39: EFXA2, 40: EFXA3, 41: EFXA4	p. 41
	B-Efx2 Specifies the effect assigned to the [2 (CHROMA KEY)] button		
	B-Efx3 Specifies the effect assigned to the [3 (LUMINANCE KEY)] button		
	B-Efx4 Specifies the effect assigned to the [4 (P in P)] button		
		<div style="border: 1px solid black; padding: 5px;"> <p>“052: SILHOUETTE1”–“060: SILHOUETTE*”, “093: W-LUMIKEY”–“098: CHROMAKEY*”, and “142: PinP1”–“149: PinP8” have a third-level sub-menu. The main menu items “Key Setup” (p. 83) and “PinP1–8 Setup” (p. 83) are shortcuts to these sub-menus.</p> </div>	
Transformer-A [Mem2]–[Mem8] *1 Specifies the function of the bus A [TRANSFORMER] button			
Transformer-B [Mem2]–[Mem8] *1 Specifies the function of the bus B [TRANSFORMER] button			
Output Fade [Mem2]–[Mem8] *1 Specifies the function of the [OUTPUT FADE] fader		01: No Control, 02: Manual, 03: Auto	p. 32
BPM SYNC [Mem2]–[Mem8] *1 Specifies the function of the [BPM SYNC] button	Mode Specifies the transition mode when using BPM sync	DirectA/B, TransitionA/B	p. 62
	Speed Specifies the multiple of the displayed BPM at which the images will be switched	BPMx1/4, BPMx1/2, BPMx1, BPMx2	

*1 Mem1 (Memory number 1) contains the factory preset settings. These settings cannot be modified. For details on the MEMORY function, refer to “Storing the Operating Panel Settings” (p. 28).

*1 For details on the factory settings for Mem1–8 (memory numbers 1–8), refer to “Factory settings: Mem1–8” (p. 88).

Main menu (First level)	Sub-menu (Second level)	Value (The factory setting is printed in bold characters.)	See page	
PC Input Setup [PC1]–[PC2] *2 Detailed settings for PC image input are made here.	Hposition Adjusts the display position in the horizontal direction	[Zoom=Off, NTSC] 1– 155 –300 [Zoom=Off, PAL] 1– 222 –300 [Zoom=On] 0–550	p. 54	
	Vposition Adjusts the display position in the vertical direction	[Zoom=Off] 1– 33 –137 [Zoom=On] 0–990		
	Hsize Adjusts the size in the horizontal direction	[NTSC] 550– 680 –870 [PAL] 550– 840 –990		
	Vsize Adjusts the size in the vertical direction	[NTSC] 250– 430 –523 [PAL] 350– 520 –623		
	Contrast Adjusts the contrast of the image	0– 32 –63		
	Brightness Adjusts the brightness of the image	0–127		
	Sharpness Adjusts the sharpness of the outline	0– 31		
	Flick Filter Adjusts the flickering of the image	0– 31		
	Color Adjusts the color of the image	0– 32 –63		
	Zoom Turns magnification of the image on/off	Off, On		
	Auto Detect Turns the Auto Detect function (automatic detection of the input resolution) on/off	Off, On		p. 55
	PC Reset Returns the sub-menu settings to the factory-set state	---		p. 34
User Transition1	Specifies the transition effect assigned to each position of the video fader	001: Mix01, 002: Fam01, 003: Nam01, 004: Wipe01–102: Wipe99, 103: SWipe01–201: SWipe99, 202: Slide01–221: Slide20	p. 38	
User Transition2				
User Transition3				
User Transition4				
Detailed settings for the “User01”–“User04” transition effects are made here.				
* For details on the factory settings, refer to p. 89.				
Position1				
Position2				
Position3				
Position4				
Position5				
Position6				
Position7				
Position8				
Switching Turns the switching function on/off	Off, BPMx1, BPMx2, BPMx4	p. 39		

*2 Use the [PC INPUT SELECT] switch to change between the PC1 and PC2 inputs.

Main menu (First level)	Sub-menu (Second level)	Value (The factory setting is printed in bold characters.)	See page
PinP1 Setup PinP2 Setup PinP3 Setup PinP4 Setup PinP5 Setup PinP6 Setup PinP7 Setup PinP8 Setup Advanced settings P in P effect are made here. * For details on the factory settings, refer to p. 89.	PinP-Hposi	0–600 (Changes according to the subscreen size.)	p. 44
	Adjusts the horizontal position of the subscreen		
	PinP-Vposi	0–207 (Changes according to the subscreen size.)	
	Adjusts the vertical position of the subscreen		
	PinP-4:3 HVsize	0–220 (Changes according to the subscreen size.)	
	Adjusts the size of the subscreen with the aspect ratio fixed at 4:3		
	PinP-Hsize	0–220 (Changes according to the subscreen position.)	
	Adjusts the horizontal size of the subscreen		
	PinP-Vsize	0–220 (Changes according to the subscreen position.)	
	Adjusts the vertical size of the subscreen		
	PinP-Border *3	0–15	
	Adjusts the border width of the subscreen		
	PinP-BColor *3	0–15	
Specifies the border color of the subscreen			
PinP-Shadow *3	0–15		
Adjusts the shadow length for the subscreen			
PinP-SColor *3	0–15		
Specifies the shadow color for the subscreen			
PinP-Trimming	0–30		
Adjusts the trimming region for the subscreen			
PinP-Reset	---	p. 34	
Returns the sub-menu settings to the factory-set state			
Key Setup Advanced settings key composite effects are made here.	White-LumiKey Level	0– 128 –255	p. 47
	Adjusts the level for luminance keying (extract white)		
	White-LumiKey Edge	1– 14 –15	
	Adjusts the soft edge level for luminance keying (extract white)		
	Black-LumiKey Level	0– 128 –255	
	Adjusts the level for luminance keying (extract black)		
	Black-LumiKey Edge	1– 14 –15	
	Adjusts the soft edge level for luminance keying (extract black)		
	ChromaKey Color	Blue-Magenta, Blue-Cyan , Red-Magenta, Red-yellow, Magenta-Red, Magenta-Blue, Cyan-Green, Green-Cyan, Green-Red, Cyan-Blue, Yellow-Green, Yellow-Red	
	Specifies the key color for chroma keying		
ChromaKey Level	0– 128 –255		
Adjust the key level for chroma keying			
ChromaKey Edge	1– 14 –15		
Adjust the soft edge level for chroma keying			
Silhouette Level	0– 128 –255		
Adjusts the threshold value between light and dark when using the “052: SILHOUETTE1”–“060: SILHOUETTE” effects			
Key Reset	---	p. 34	
Returns the sub-menu settings to the factory-set state			

*3 If a key-compositing effect (W-LUMIKEY, B-LUMIKEY, CHROMAKEY) is on, the border and shadow of the subscreen will not be shown.

Main menu (First level)	Sub-menu (Second level)	Value (The factory setting is printed in bold characters.)	See page
Memory Edit Copies or exchanges the contents of memory	Copy Mem* -> Mem* Copy the contents of the selected memory dial setting to another number Copy Mem* -> All Copy the contents of the setting to all numbers Exchange Mem* <-> Mem* Exchange the contents of the selected memory dial setting with another number	---	p. 29 p. 30
MIDI Setup MIDI-related settings are made here.	MIDI Tx Channel Sets MIDI transmit channel	1–16	p. 66
	MIDI Rx Channel Sets MIDI receive channel	1–16, Off	p. 68
	MIDI Out/Thru Switch MIDI OUT/THRU connector function	Out, Thru	p. 66
	V-LINK Switch Switches V-LINK mode on and off	Off, On	p. 73
	Note Mode Turns note message reception on/off	Off, 49Keys Mode, Assign Mode	p. 68
	Note Lower Key Assign Specifies the lowest note of the note range when the “MIDI Setup” parameter “Note Mode” is set to “Assign Mode”	C-1 [0X00]–C+2 [0X24]–G+9 [0X7F]	
	Note Upper Key Assign Specifies the highest note of the note range when the “MIDI Setup” parameter “Note Mode” is set to “Assign Mode”	C-1 [0X00]–D+3*[0X33]–G+9 [0X7F]	
	Device ID Sets Device ID	0x00–0x10–0x1F	---
	Input Select A Assign Specifies the MIDI message assigned to the bus A INPUT SELECT buttons	CC 00 + CC 32 + PC, CC 01–CC 05, CC 07–CC 31, CC 64–CC 95, ChAftTt, PitchBD	p. 65
	Input Select B Assign Specifies the MIDI message assigned to the bus B INPUT SELECT buttons	CC 00 + CC 32 + PC, CC 01–CC 05, CC 07–CC 31, CC 64–CC 95, ChAftTt, PitchBD	
	Specifies the MIDI messages assigned to each button or fader	OFF, CC 01–CC 05, CC 07–CC 31, CC 64–CC 95, ChAftTt, PitchBD	
	Effects-A1 Assign [1 (FEEDBACK)] button		
	Effects-A2 Assign [2 (NEGATIVE)] button		
Effects-A3 Assign [3 (COLORIZE)] button			
Effects-A4 Assign [4 (MULTI)] button			
Effects-B1 Assign [1 (FLIP)] button			
Effects-B2 Assign [2 (CHROMA KEY)] button			
Effects-B3 Assign [3 (LUMINANCE KEY)] button			
Effects-B4 Assign [4 (P in P)] button			

Main menu (First level)	Sub-menu (Second level)	Value (The factory setting is printed in bold characters.)	See page
MIDI Setup (continued) MIDI-related settings are made here.	Specifies the MIDI messages assigned to each button or fader Fade A Switch Assign Bus A [FADE] button Fade B Switch Assign Bus B [FADE] button Control A Assign Bus A [CONTROL] fader Control B Assign Bus B [CONTROL] fader	OFF , CC 01–CC 05, CC 07–CC 31, CC 64–CC 95, ChAftTt, PitchBD	p. 65
	Video Fader Assign Specifies the MIDI message assigned to the Video fader	OFF , CC 01–CC 05, CC 07– CC 11 –CC 31, CC 64–CC 95, ChAftTt, PitchBD	
	Specifies the MIDI messages assigned to each button or fader Transition Assign TRANSITION buttons Transformer A Assign Bus A [TRANSFORMER] button Transformer B Assign Bus B[TRANSFORMER] button BPM SYNC Assign [BPM SYNC] button	OFF , CC 01–CC 05, CC 07–CC 31, CC 64–CC 95, ChAftTt, PitchBD	
	Transition Time Assign Specifies the MIDI message that will adjust the transition time when using PR Control Mode (p. 75)	OFF , CC 01–CC 05, CC 07 –CC 31, CC 64–CC 95, ChAftTt, PitchBD	
	Specifies the MIDI messages assigned to each button or fader BPM/CONTROL Assign [BPM/CONTROL] knob Output Fade Assign [OUTPUT FADE] fader White/Black Assign [WHITE/BLACK] switch PC Input Select Assign [PC INPUT SELECT] switch Preview Output Assign PREVIEW OUTPUT SELECT buttons	OFF , CC 01–CC 05, CC 07–CC 31, CC 64–CC 95, ChAftTt, PitchBD	
	Memory Assign Specifies the MIDI message assigned to the [MEMORY] knob	CC 00 + CC 32 + PC , CC 01–CC 05, CC 07–CC 31, CC 64–CC 95, ChAftTt, PitchBD	
	Panel Mode [Mem2]–[Mem8] *4 Turns MIDI message transmission on/off when buttons or faders are operated	01: Video+MidiOut, 02: Video Only, 03: Midi Out Only	p. 67
	PR Control Turns PR Control Mode on/off	Off , On	p. 75

*4 Mem1 (Memory number 1) contains the factory preset settings. These settings cannot be modified. For details on the MEMORY function, refer to “Storing the Operating Panel Settings” (p. 28).

*4 For details on the factory settings for Mem1–8 (memory numbers 1–8), refer to “Factory settings: Mem1–8” (p. 88).

Main menu (First level)	Sub-menu (Second level)	Value (The factory setting is printed in bold characters.)	See page
MIDI Setup (continued) MIDI-related settings are made here.	MIDI Bulk Dump Transmits the settings to MIDI-connected devices	---	p. 69
	MIDI Reset Returns the sub-menu settings to the factory-set state.	---	p. 34
Utility Settings for the V-8 itself	Memory Protect Turns memory protect on/off	Off, On	p. 25
	Video Sync Threshold Adjusts the video input synchronization signal level	-48- 0 -+79	p. 56
	VideoA Bright Adjust Adjusts the brightness of the image being input to bus A.	-60- 0 -+61	
	VideoA Color Adjust Adjusts the color of the image being input to bus A.	-10- 0 -+11	
	VideoA Hue Adjust Adjusts the hue of the image being input to bus A.	-125- 0 -+126	
	VideoB Bright Adjust Adjusts the brightness of the image being input to bus B.	-60- 0 -+61	
	VideoB Color Adjust Adjusts the color of the image being input to bus B.	-10- 0 -+11	
	VideoB Hue Adjust Adjusts the hue of the image being input to bus B.	-125- 0 -+126	
	Video Display Range H Adjusts the horizontal size of the final output image.	0 -30	
	Video Display Range V Adjusts the vertical size of the final output image.	0 -30	
	Video Out Black Level Adjusts the black level reference (setup level) of the output signal.	0 IRE, 7.5 IRE	
	Video Fader Mode Sets the mode used for video fader operating	Normal, Quick	p. 78
	Video Fader Curve Sets the video fader operating curve	Curve-A, Curve-B, Curve-C	p. 78
	Video Fader Calibrate A Calibrates the video fader for bus A	---	p. 77
	Video Fader Calibrate B Calibrates the video fader for bus B	---	
Input Select Delay Time Transition time when the INPUT SELECT buttons are operated	0- 10 -30 (Field)	p. 35	

Main menu (First level)	Sub-menu (Second level)	Value (The factory setting is printed in bold characters.)	See page
Utility (continued) Settings for the V-8 itself	OutFade White Level Adjusts the white level of the [OUTPUT FADE] fader	0- 200 -255	p. 32
	OutFade Black Level Adjusts the black level of the [OUTPUT FADE] fader	0 -255	
	Preview Display Mode Specifies the settings shown in the preview monitor	No display, Mode1, Mode2 , Mode3	p. 27
	Preview Switch Pattern Specifies the selection method for the preview output	Manual , Prev Auto, Always-1-8, Always-Out, Auto1-2-1-8, Auto1-Out	p. 22
	Preview Auto Speed Specifies the automatic transition time for the preview output	1-5-10	
	Preview Signal Check Turns on/off the preview output when no signal is present	Off, On	p. 22
	Preview No Signal Color Specifies the preview output color when no signal is present	Cyan , Yellow, Red, Blue, SkyBlue, Green, Orange, Magenta	
	No Signal Blueback Turns on/off blue-back output when no signal is present	Off , On	p. 21
	OSD Horizontal Locate Adjusts the horizontal location of the on-screen display	-15- 0 +15	p. 25
	OSD Vertical Locate Adjusts the horizontal location of the on-screen display	-5- 0 +5	
	Color Bar Out Turns color bar output on/off	Off , On	p. 58
	Utility Reset Returns the sub-menu settings to the factory-set state.	---	p. 34
NTSC/PAL *5 Switches between NTSC and PAL.	NTSC, PAL	p. 59	
Factory Reset This restores the V-8 to its original factory default settings.	---	p. 33	

*5 The factory setting varies depending on the country.

Factory Settings

Mem1–8 (Memory Numbers 1–8)

	Mem1	Mem2	Mem3	Mem4
1. Mix (Trans1)	001: Mix01	001: Mix01	001: Mix01	002: Fam01
2. Wipe (Trans2)	008: Wipe03	007: Wipe02	053: Wipe48	093: Wipe88
3. Efx (Trans3)	192: SWipe88	137: SWipe33	208: Slide01	260: User01
Effects-A: A-Efx1	022: FEEDBACK*	017: AFTERIMAGE*	060: SILHOUETTE*	017: AFTERIMAGE*
Effects-A: A-Efx2	033: NEGATIVE*	083: POSTERIZE*	069: MONOCOLOR*	069: MONOCOLOR*
Effects-A: A-Efx3	042: COLORIZE*	051: FINDEDGE*	028: SHAKE6*	028: SHAKE6*
Effects-A: A-Efx4	126: MULTI-HV*	141: MIRROR-HV*	126: MULTI-HV*	126: MULTI-HV*
Effects-B: B-Efx1	102: FLIP*	102: FLIP*	102: FLIP*	102: FLIP*
Effects-B: B-Efx2	098: CHROMAKEY*	098: CHROMAKEY*	098: CHROMAKEY*	098: CHROMAKEY*
Effects-B: B-Efx3	096: B-LUMIKEY*	096: B-LUMIKEY*	096: B-LUMIKEY*	096: B-LUMIKEY*
Effects-B: B-Efx4	150: PinP*	150: PinP*	150: PinP*	150: PinP*
Transformer-A	02: Trans	02: Trans	02: Trans	40: EFXA3
Transformer-B	02: Trans	02: Trans	02: Trans	38: EFXB1
Output Fade	02: Manual	02: Manual	02: Manual	02: Manual
BPM SYNC: Mode	TransitionA/B	TransitionA/B	TransitionA/B	TransitionA/B
BPM SYNC: Speed	BPMx2	BPMx2	BPMx2	BPMx2
MIDI Setup: Panel Mode	01: Video+MidiOut	01: Video+MidiOut	01: Video+MidiOut	01: Video+MidiOut
	Mem5	Mem6	Mem7	Mem8
1. Mix (Trans1)	004: Nam01	001: Mix01	001: Mix01	001: Mix01
2. Wipe (Trans2)	172: SWipe68	038: Wipe33	008: Wipe03	008: Wipe03
3. Efx (Trans3)	233: Slide26	093: Wipe88	214: Slide07	107: SWipe03
Effects-A: A-Efx1	022: FEEDBACK*	012: STROBE*	001: STILL1	012: STROBE*
Effects-A: A-Efx2	078: EMBOSS*	033: NEGATIVE*	033: NEGATIVE*	033: NEGATIVE*
Effects-A: A-Efx3	092: COLORPASS*	042: COLORIZE*	042: COLORIZE*	042: COLORIZE*
Effects-A: A-Efx4	141: MIRROR-HV*	083: POSTERIZE*	069: MONOCOLOR*	126: MULTI-HV*
Effects-B: B-Efx1	012: STROBE*	142: PinP1	001: STILL1	141: MIRROR-HV*
Effects-B: B-Efx2	098: CHROMAKEY*	145: PinP4	094: W-LUMIKEY*	098: CHROMAKEY*
Effects-B: B-Efx3	096: B-LUMIKEY*	147: PinP6	096: B-LUMIKEY*	096: B-LUMIKEY*
Effects-B: B-Efx4	150: PinP*	149: PinP8	144: PinP3	142: PinP1
Transformer-A	33: White	02: Trans	02: Trans	02: Trans
Transformer-B	34: Black	02: Trans	02: Trans	02: Trans
Output Fade	02: Manual	02: Manual	02: Manual	02: Manual
BPM SYNC: Mode	TransitionA/B	TransitionA/B	TransitionA/B	TransitionA/B
BPM SYNC: Speed	BPMx2	BPMx2	BPMx2	BPMx1
MIDI Setup: Panel Mode	01: Video+MidiOut	01: Video+MidiOut	01: Video+MidiOut	01: Video+MidiOut

User Transition1–4

	User Transition 1	User Transition2	User Transition3	User Transition4
Position1	097: Wipe94	008: Wipe05	052: Wipe49	090: Wipe87
Position2	094: Wipe91	009: Wipe06	058: Wipe55	079: Wipe76
Position3	092: Wipe89	012: Wipe09	055: Wipe52	102: Wipe99
Position4	091: Wipe88	013: Wipe10	056: Wipe53	047: Wipe44
Position5	093: Wipe90	015: Wipe12	052: Wipe49	027: Wipe24
Position6	095: Wipe92	016: Wipe13	058: Wipe55	071: Wipe68
Position7	096: Wipe93	017: Wipe14	055: Wipe52	027: Wipe24
Position8	097: Wipe94	019: Wipe16	056: Wipe53	090: Wipe87
Switching	Off	Off	BPMx2	Off

PinP1–8

	PinP1	PinP2	PinP3	PinP4	PinP5	PinP6	PinP7	PinP8
Hposi	450	65	450	65	0	163	210	87
Vposi	187	187	64	64	207	150	131	178
4:3HVsize	40	40	40	40	160	160	80	160
Hsize	40	40	40	40	160	160	80	160
Vsize	40	40	40	40	160	160	80	160
Border	3	3	3	3	6	6	6	4
BColor	1	1	1	1	1	9	1	1
Shadow	0	0	0	0	0	0	11	11
SColor	0	0	0	0	0	0	0	14
Trimming	5	5	5	5	5	5	5	5

MIDI Implementation

Model: V-8 Version: 1.00 Date: Jan. 10. 2008

Symbol	Item	Setting range
n:	MIDI channel	0H - FH (ch.1 - ch.16)
vv:	Control value	00H - 7FH (0 - 127)
xx:	Switch on and off	00H - 3FH (0 - 63): OFF 40H - 7FH (64 - 127): ON

1. MIDI messages received at MIDI IN

* If MIDI Thru is ON, MIDI messages received at MIDI IN will be retransmitted without change from MIDI OUT.

■ Channel Voice Message

● Note-on

Status	2nd byte	3rd byte
9nH	kkH	vvH

* Received only if Note Mode is ON.

* The input of each channel is selected. Ignored if a non-selectable note message is received.

* The correspondence between note numbers and channels in 49Keys Mode is shown below.

Note No.	Input
24H	A Ch.1
26H	A Ch.2
28H	A Ch.3
29H	A Ch.4
2BH	A Ch.5
2DH	A Ch.6
2FH	A Ch.7
30H	A Ch.8

32H	B Ch.1
34H	B Ch.2
35H	B Ch.3
37H	B Ch.4
39H	B Ch.5
3BH	B Ch.6
3CH	B Ch.7
3EH	B Ch.8

● Control Change

* By making settings in MIDI Setup, you can use these messages to control a wide variety of things. The control changes that can be used "Settings Transmitted/Received Using MIDI" (p. 96).

○ Bank Select (controller numbers 0, 32)

Status	2nd byte	3rd byte
BnH	00H	mmH
BnH	20H	llH

mm, ll = bank number: 00 00H - 7F 7FH (bank.1 - bank.16384)

* Processing of a Bank Select message is suspended until a subsequent Program Change is received.

* Bank Select data that is received will be maintained until a subsequent Bank Select is received.

* This selects the input for each channel.

* Bank Select LSB will be ignored.

Controls correspond to bank select messages as follows.

Bank Select MSB LSB	Program No.	Control
50H 00H (bank.10241)	00H - 07H	MEMORY 1 - 8
00H 00H (bank.1)	00H - 07H	Bus A INPUT 1 - 8
01H 00H (bank.129)	00H - 07H	Bus B INPUT 1 - 8

○ Modulation (controller numbers 1)

Status	2nd byte	3rd byte
BnH	01H	vvH

○ Breath-type (controller numbers 2)

Status	2nd byte	3rd byte
BnH	02H	vvH

○ Foot-type (controller numbers 4)

Status	2nd byte	3rd byte
BnH	04H	vvH

○ Portamento Time (controller numbers 5)

Status	2nd byte	3rd byte
BnH	05H	vvH

○ Volume (controller numbers 7)

Status	2nd byte	3rd byte
BnH	07H	vvH

○ Balance (controller numbers 8)

Status	2nd byte	3rd byte
BnH	08H	vvH

○ Panpot (controller numbers 10)

Status	2nd byte	3rd byte
BnH	0AH	vvH

○ Expression (controller numbers 11)

Status	2nd byte	3rd byte
BnH	0BH	vvH

○ Effect Control 1 (controller numbers 12)

Status	2nd byte	3rd byte
BnH	0CH	vvH

○ Effect Control 2 (controller numbers 13)

Status	2nd byte	3rd byte
BnH	0DH	vvH

○ General Purpose Controllers 1-4 (controller numbers 16-19)

Status	2nd byte	3rd byte
BnH	10H - 13H	vvH

○ Hold 1 (controller numbers 64)

Status	2nd byte	3rd byte
BnH	40H	xxH

○ Portamento (controller numbers 65)

Status	2nd byte	3rd byte
BnH	41H	xxH

○ Sostenuto (controller numbers 66)

Status	2nd byte	3rd byte
BnH	42H	xxH

○ Soft (controller numbers 67)

Status	2nd byte	3rd byte
BnH	43H	xxH

○ Legato (controller numbers 68)

Status	2nd byte	3rd byte
BnH	44H	xxH

○ Hold 2 (controller numbers 69)

Status	2nd byte	3rd byte
BnH	45H	xxH

○ Sound Controllers 1-10 (controller numbers 70-79)

Status	2nd byte	3rd byte
BnH	46- FH	vvH

○ General Purpose Controllers 5-8 (controller numbers 80-83)

Status	2nd byte	3rd byte
BnH	50 - 53FH	vvH

○ Portamento Control (controller numbers 84)

Status	2nd byte	3rd byte
BnH	54H	vvH

○ Effect Depth 2-5 (controller numbers 92-95)

Status	2nd byte	3rd byte
BnH	5C - 5FH	vvH

●Program Change

<u>Status</u>	<u>2nd byte</u>
CnH	ppH

pp = program number: 00H - 7FH (prog.1 - prog.128)

- * This selects the input channels. For more detailed information refer to the Bank Select parameters.
- * If a non-selectable Program Change is received, it will be ignored.

●Channel Pressure

<u>Status</u>	<u>2nd byte</u>
DnH	vvH

- * Just as for Control Change messages, you can make settings in MIDI Setup to use Channel Pressure messages to control a wide variety of things. For details on the factory settings, refer to "Settings Transmitted/Received Using MIDI" (p. 96).

●Pitch Bend Change

<u>Status</u>	<u>2nd byte</u>	<u>3rd byte</u>
EnH	llH	mmH

mm, ll = pitch bend value: 00 00H - 40 00H - 7F 7FH (-8192 - 0 - +8191)

- * Just as for Control Change messages, you can make settings in MIDI Setup to use Channel Pressure messages to control a wide variety of things. For details on the factory settings, refer to "Settings Transmitted/Received Using MIDI" (p. 96).

■System realtime messages**●Active Sensing**

<u>Status</u>
FEH

- * Once an Active Sensing message is received, the system will begin monitoring the interval between all subsequent messages. If there is an interval of greater than approximately 400 ms between messages while monitoring is occurring, the system will perform reception error processing and will then stop monitoring the message interval.

●Timing Clock

<u>Status</u>
F8H

- * Used to synchronize BPM SYNC.

●Start

<u>Status</u>
FAH

- * Specifies the beginning of the beat for BPM SYNC.

■System exclusive messages

<u>Status</u>	<u>Data bytes</u>	<u>Status</u>
F0H	iiH, ddH, ..., eeH	F7H

F0H: System Exclusive Message status
 ii = ID number: An ID number (manufacturer ID) that indicates the manufacturer to which the exclusive message belongs. Roland's manufacturer ID is 41H. ID numbers 7EH and 7FH are used for Universal Non-realtime Messages (7EH) and Universal Realtime Messages (7FH) to extend the MIDI specification.

dd, .. ee = data: 00H-7FH (0-127)
 F7H: EOX (End Of Exclusive)

●Data Set 1 (DT1)

This is the message that transfers actual data, and is used to specify data for a device.

<u>Status</u>	<u>Data bytes</u>	<u>Status</u>
F0H	41H, dev, 00H, 00H, 28H, 12H, aaH, bbH, ccH, ddH, ..., eeH, sum	F7H

<u>Byte</u>	<u>Explanation</u>
F0H	Exclusive status
41H	ID number (Roland)
dev	Device ID (dev: 00H-FH, factory setting is 10H, 7FH is Broadcast)
00H	1st byte of model ID (V-8)
00H	2nd byte of model ID (V-8)
28H	3rd byte of model ID (V-8)
12H	Command ID (DT1)
aaH	Upper byte of address
bbH	Address
ccH	Address
ddH	Data: the actual data to be transmitted. Multi-byte data is transmitted in the order of the address
:	:
eeH	Data
sum	Checksum
F7H	EOX (End Of Exclusive)

<u>Status</u>	<u>Data bytes</u>	<u>Status</u>
F0H	41H, dev, 00H, 51H, 12H, F7H aaH, bbH, ccH, ddH, ..., eeH, sum	

<u>Byte</u>	<u>Explanation</u>
F0H	Exclusive status
41H	ID number (Roland)
dev	Device ID (dev: 00H-FH, factory setting is 10H, 7FH is Broadcast)
00H	Upper byte of model ID (V-Link message)
51H	Lower byte of model ID (V-Link message)
12H	Command ID (DT1)
aaH	Upper byte of address
bbH	Address
ccH	Address
ddH	Data: the actual data to be transmitted. Multi-byte data is transmitted in the order of the address.
eeH	Data
sum	Checksum
F7H	EOX (End Of Exclusive)

- * For details on setting the address, size, and checksum, refer to "Exclusive message examples and checksum calculation" (p. 96).

- * Data that exceeds 256 bytes must be divided into packets of 256 bytes or less for transmission. If a subsequent "Data Set 1" message is transmitted, an interval of at least 20 ms must be left between packets.

2. MIDI messages transmitted from MIDI OUT

- * If MIDI Thru is ON, MIDI messages received at MIDI IN are re-transmitted without change from MIDI OUT.
- * If MIDI Thru is ON, messages from the V-8 itself will not be transmitted.

■ Channel voice messages

● Control Change

- * The messages assigned in MIDI Setup will be transmitted when you operate the panel. The control changes that can be used are CC#1–5, 7–31, and 64–95. For the factory settings, refer to "Settings Transmitted/Received Using MIDI" (p. 96).

○ Bank Select (controller numbers 0, 32)

Status	2nd byte	3rd byte
BnH	00H	mmH
BnH	20H	llH

mm, ll = bank number: 00 00H - 7F 7FH (bank.1 - bank.16384)

- * Sent in combination with Program Change message when an input selection is made.
- * The following controls correspond to each Bank Select message.

Bank Select MSB LSB	Program No.	Control
50H 00H (bank.10241)	00H - 07H	MEMORY 1 - 8
00H 00H (bank.1)	00H - 07H	Bus A INPUT 1 - 8
01H 00H (bank.129)	00H - 07H	Bus B INPUT 1 - 8

○ Modulation (controller numbers 1)

Status	2nd byte	3rd byte
BnH	01H	vvH

○ Breath-type (controller numbers 2)

Status	2nd byte	3rd byte
BnH	02H	vvH

○ Foot-type (controller numbers 4)

Status	2nd byte	3rd byte
BnH	04H	vvH

○ Portamento Time (controller numbers 5)

Status	2nd byte	3rd byte
BnH	05H	vvH

○ Volume (controller numbers 7)

Status	2nd byte	3rd byte
BnH	07H	vvH

○ Balance (controller numbers 8)

Status	2nd byte	3rd byte
BnH	08H	vvH

○ Panpot (controller numbers 10)

Status	2nd byte	3rd byte
BnH	0AH	vvH

○ Expression (controller numbers 11)

Status	2nd byte	3rd byte
BnH	0BH	vvH

○ Effect Control 1 (controller numbers 12)

Status	2nd byte	3rd byte
BnH	0CH	vvH

○ Effect Control 2 (controller numbers 13)

Status	2nd byte	3rd byte
BnH	0DH	vvH

○ General Purpose Controller 1–4 (controller numbers 16–19)

Status	2nd byte	3rd byte
BnH	10H - 13H	vvH

○ Hold 1 (controller numbers 64)

Status	2nd byte	3rd byte
BnH	40H	xxH

○ Portamento (controller numbers 65)

Status	2nd byte	3rd byte
BnH	41H	xxH

○ Sostenuto (controller numbers 66)

Status	2nd byte	3rd byte
BnH	42H	xxH

○ Soft (controller numbers 67)

Status	2nd byte	3rd byte
BnH	43H	xxH

○ Legato (controller numbers 68)

Status	2nd byte	3rd byte
BnH	44H	xxH

○ Hold 2 (controller numbers 69)

Status	2nd byte	3rd byte
BnH	45H	xxH

○ Sound Controllers 1–10 (controller numbers 70–79)

Status	2nd byte	3rd byte
BnH	46 - 4FH	vvH

○ General Purpose Controllers 5–8 (controller numbers 80–83)

Status	2nd byte	3rd byte
BnH	50 - 53FH	vvH

○ Portamento Control (controller numbers 84)

Status	2nd byte	3rd byte
BnH	54H	vvH

○ Effect Depth 2–5 (controller numbers 92–95)

Status	2nd byte	3rd byte
BnH	5C - 5FH	vvH

● Program Change

Status	2nd byte
CnH	ppH

pp = program number: 00H - 7FH (prog.1 - prog.128)

- * Sent in combination with Program Change message when an input selection is made. For more detailed information refer to the Bank Select parameters.

● Channel Pressure

Status	2nd byte
DnH	vvH

- * Just as for Control Changes, the messages assigned in MIDI Setup will be transmitted when you operate the panel. For the factory settings, refer to "Settings Transmitted/Received Using MIDI" (p. 96).

● Pitch Bend Change

Status	2nd byte	3rd byte
EnH	llH	mmH

mm, ll = pitch bend value: 00 00H - 40 00H - 7F 7FH (-8192 - 0 - +8191)

- * Just as for Control Changes, the messages assigned in MIDI Setup will be transmitted when you operate the panel. For the factory settings, refer to "Settings Transmitted/Received Using MIDI" (p. 96).

● Data Set 1 (DT1)

This is the message that transfers actual data, and is used to specify data for a device.

Status	Data bytes	Status
F0H	41H, dev, 00H, 00H, 28H, 12H, aaH, bbH, ccH, ddH, ..., eeH, sum	F7H

Byte	Explanation
F0H	Exclusive status
41H	ID number (Roland)
dev	Device ID (dev: 00H - 1FH, factory setting is 10H)
00H	1st byte of model ID (V-8)
00H	2nd byte of model ID (V-8)
28H	3rd byte of model ID (V-8)
12H	Command ID (DT1)
aaH	Upper byte of address
bbH	Address
ccH	Address
ddH	Data: the actual data to be transmitted. Multi-byte data is transmitted in the order of the address.
:	:
eeH	Data
sum	Checksum
F7H	EOX (End Of Exclusive)

- * For details on setting the address, size, and checksum, refer to "Exclusive message examples and checksum calculation" (p. 96).

- * Data that exceeds 256 bytes must be divided into packets of 256 bytes or less for transmission. If a subsequent "Data Set 1" message is transmitted, an interval of at least 20 ms must be left between packets.

3. Parameter Address Map

■3-1. V-8 (Model ID = 00H 00H 28H)

* Addresses marked by # are sent as two bytes; an upper nibble (upper 4 bits) and lower nibble (lower 4 bits).

Example) If the original data is BCH, 0BH is transmitted as the first byte.

The next byte transmitted is 0CH. For reception, this is ignored if two bytes are not received together.

* Do not transmit data to the address whose Parameter Name is "Reserve".

* The factory-default Device ID is 10H.

Start Address	Description
00H 00H 00H	System Common Preference Area (See 3-1-1)
01H 00H 00H	Fader Control Preference Area (See 3-1-2)
02H 00H 00H	Effects Control Preference Area (See 3-1-3)
03H 00H 00H	Reserved Area
12H 00H 00H	Fader Control Parameter Area (See 3-1-4)
20H 00H 00H	Bulk Dump Area (See 3-1-5)

●3-1-1. System Common Preference

Address	Parameter Name	Sys.Ex.Value	Meaning of Value
00H 00H 00H	MIDI Transmit Channel	00H - 0FH	1 - 16 Ch.
00H 00H 01H	MIDI Receive Channel	00H - 10H	1 - 16 Ch., OFF

●3-1-2. Fader Control Preference

Address	Parameter Name	Sys.Ex.Value	Meaning of Value
#01H 10H 00H	Tx/Rx Setting (Input Select A Assign)	01H-05H, 07H-1FH, 40H-5FH, D0H, E0H, FFH	Control Change, Channel Press, Pitch Bend, Program Change (bank.1)
#01H 10H 02H	Tx/Rx Setting (Input Select B Assign)	01H-05H, 07H-1FH, 40H-5FH, D0H, E0H, FFH	Control Change, Channel Press, Pitch Bend, Program Change (bank.129)
#01H 10H 04H	Tx/Rx Setting (FADE A Switch Assign)	01H-05H, 07H-1FH, 40H-5FH, D0H, E0H, FFH	Control Change, Channel Press, Pitch Bend, OFF
#01H 10H 06H	Tx/Rx Setting (FADE B Switch Assign)	01H-05H, 07H-1FH, 40H-5FH, D0H, E0H, FFH	Control Change, Channel Press, Pitch Bend, OFF
#01H 10H 08H	Tx/Rx Setting (Control A Assign)	01H-05H, 07H-1FH, 40H-5FH, D0H, E0H, FFH	Control Change, Channel Press, Pitch Bend, OFF
#01H 10H 0AH	Tx/Rx Setting (Control B Assign)	01H-05H, 07H-1FH, 40H-5FH, D0H, E0H, FFH	Control Change, Channel Press, Pitch Bend, OFF
#01H 10H 0CH	Tx/Rx Setting (Video Fader Assign)	01H-05H, 07H-1FH, 40H-5FH, D0H, E0H, FFH	Control Change, Channel Press, Pitch Bend, OFF
#01H 10H 0EH	Tx/Rx Setting (Transition Assign)	01H-05H, 07H-1FH, 40H-5FH, D0H, E0H, FFH	Control Change, Channel Press, Pitch Bend, OFF
#01H 10H 10H	Tx/Rx Setting (Transformer A Assign)	01H-05H, 07H-1FH, 40H-5FH, D0H, E0H, FFH	Control Change, Channel Press, Pitch Bend, OFF
#01H 10H 12H	Tx/Rx Setting (Transformer B Assign)	01H-05H, 07H-1FH, 40H-5FH, D0H, E0H, FFH	Control Change, Channel Press, Pitch Bend, OFF
#01H 10H 14H	Tx/Rx Setting (BPM SYNC Assign)	01H-05H, 07H-1FH, 40H-5FH, D0H, E0H, FFH	Control Change, Channel Press, Pitch Bend, OFF
#01H 10H 16H	Tx/Rx Setting (Transition Time Assign)	01H-05H, 07H-1FH, 40H-5FH, D0H, E0H, FFH	Control Change, Channel Press, Pitch Bend, OFF
#01H 10H 18H	Tx/Rx Setting (BPM CONTROL Assign)	01H-05H, 07H-1FH, 40H-5FH, D0H, E0H, FFH	Control Change, Channel Press, Pitch Bend, OFF
#01H 10H 1AH	Tx/Rx Setting (Output Fade Assign)	01H-05H, 07H-1FH, 40H-5FH, D0H, E0H, FFH	Control Change, Channel Press, Pitch Bend, OFF
#01H 10H 1CH	Tx/Rx Setting (White/Black Assign)	01H-05H, 07H-1FH, 40H-5FH, D0H, E0H, FFH	Control Change, Channel Press, Pitch Bend, OFF
#01H 10H 1EH	Tx/Rx Setting (PC Input Select Assign)	01H-05H, 07H-1FH, 40H-5FH, D0H, E0H, FFH	Control Change, Channel Press, Pitch Bend, OFF
#01H 10H 20H	Tx/Rx Setting (Preview Output Assign)	01H-05H, 07H-1FH, 40H-5FH, D0H, E0H, FFH	Control Change, Channel Press, Pitch Bend, OFF
#01H 10H 22H	Tx/Rx Setting (Memory Assign)	01H-05H, 07H-1FH, 40H-5FH, D0H, E0H, FFH	Control Change, Channel Press, Pitch Bend, Program Change (bank.10241)

●3-1-3. Effects Control Preference

Address	Parameter Name	Sys.Ex.Value	Meaning of Value
#02H 10H 00H	Tx/Rx Setting (Effect-A1 Assign)	01H-05H, 07H-1FH, 40H-5FH, D0H, E0H, FFH	Control Change, Channel Press, Pitch Bend, OFF
#02H 10H 02H	Tx/Rx Setting (Effect-A2 Assign)	01H-05H, 07H-1FH, 40H-5FH, D0H, E0H, FFH	Control Change, Channel Press, Pitch Bend, OFF
#02H 10H 04H	Tx/Rx Setting (Effect-A3 Assign)	01H-05H, 07H-1FH, 40H-5FH, D0H, E0H, FFH	Control Change, Channel Press, Pitch Bend, OFF
#02H 10H 06H	Tx/Rx Setting (Effect-A4 Assign)	01H-05H, 07H-1FH, 40H-5FH, D0H, E0H, FFH	Control Change, Channel Press, Pitch Bend, OFF
#02H 10H 08H	Tx/Rx Setting (Effect-B1 Assign)	01H-05H, 07H-1FH, 40H-5FH, D0H, E0H, FFH	Control Change, Channel Press, Pitch Bend, OFF
#02H 10H 0AH	Tx/Rx Setting (Effect-B2 Assign)	01H-05H, 07H-1FH, 40H-5FH, D0H, E0H, FFH	Control Change, Channel Press, Pitch Bend, OFF
#02H 10H 0CH	Tx/Rx Setting (Effect-B3 Assign)	01H-05H, 07H-1FH, 40H-5FH, D0H, E0H, FFH	Control Change, Channel Press, Pitch Bend, OFF
#02H 10H 0EH	Tx/Rx Setting (Effect-B4 Assign)	01H-05H, 07H-1FH, 40H-5FH, D0H, E0H, FFH	Control Change, Channel Press, Pitch Bend, OFF

●3-1-4. Fader Control Parameter

Address	Parameter Name	Sys.Ex.Value	Meaning of Value
12H 00H 00H	----	----	----
12H 00H 01H	Note Mode	00H - 01H	OFF, ON

●3-1-4. Bulk Dump Parameter

Address	Parameter Name	Sys.Ex.Value	Meaning of Value
20H 00H 00H	----	----	----
:	:	:	:
2FH 7FH 00H	----	----	----

■3-2. V-LINK slave (Model ID = 00H 51H)

* Addresses marked by # are sent as two bytes; an upper nibble (upper 4 bits) and lower nibble (lower 4 bits).

Example) If the original data is BCH, 0BH is transmitted as the first byte.

The next byte transmitted is 0CH. For reception, this is ignored if two bytes are not received together.

* If --- is shown in the value field, the V-8 does not have a corresponding parameter. This will be ignored if received.

Start Address	Description
10H 00H 00H	V-LINK System Preference Area (See 3-2-1)
10H 10H 00H	V-LINK Clip Control Assignment Area (See 3-2-2)
10H 20H 00H	V-LINK Color Control Assignment Area (See 3-2-3)
10H 30H 00H	V-LINK Clip Control Preference Area (See 3-2-4)

●3-2-1. System Preference

Address	Parameter Name	Sys.Ex.Value	Meaning of Value
10H 00H 00H	V-LINK Enabled	00H - 01H	OFF, ON
10H 00H 01H	V-LINK MIDI Rx Channel (Clip)	00H - 0FH	1 - 16 Ch.
10H 00H 02H	V-LINK MIDI Rx Channel (Color)	---	---
10H 00H 03H	V-LINK Note Message Enabled	00H - 02H	Note Mode: OFF, 49 Keys, Assignable
10H 00H 04H	V-LINK Fast Control Enabled	---	---
10H 00H 05H	V-LINK MMC Control Mode	---	---
10H 00H 06H	V-LINK MTC Control Mode	---	---
10H 00H 07H	V-LINK Auto Mix Mode	00H - 01H	PR Mode: OFF, ON

●3-2-2. Clip Control Assignment

Address	Parameter Name	Sys.Ex.Value	Meaning of Value
#10H 10H 00H	V-LINK Rx Setting (Playback Speed)	---	---
#10H 10H 02H	V-LINK Rx Setting (Dissolve Time)	---	---
#10H 10H 04H	V-LINK Rx Setting (Audio Level)	---	---
#10H 10H 06H	V-LINK Rx Setting (T-Bar Control)	01H-05H, 07H-1FH, 40H-5FH, DOH, E0H, FFH	Video Fader: Control Change, Channel Press, Pitch Bend, OFF
#10H 10H 08H	V-LINK Rx Setting (Dual Stream)	---	---
#10H 10H 0AH	V-LINK Reserved	---	---
#10H 10H 0CH	V-LINK Reserved	---	---
#10H 10H 0EH	V-LINK Reserved	---	---
#10H 10H 10H	V-LINK Rx Setting (Transition Select)	01H-05H, 07H-1FH, 40H-5FH, DOH, E0H, FFH	Control Change, Channel Press, Pitch Bend, OFF
#10H 10H 12H	V-LINK Rx Setting (Transformer A)	01H-05H, 07H-1FH, 40H-5FH, DOH, E0H, FFH	Control Change, Channel Press, Pitch Bend, OFF
#10H 10H 14H	V-LINK Rx Setting (Transformer B)	01H-05H, 07H-1FH, 40H-5FH, DOH, E0H, FFH	Control Change, Channel Press, Pitch Bend, OFF
#10H 10H 16H	V-LINK Rx Setting (BPM Sync)	01H-05H, 07H-1FH, 40H-5FH, DOH, E0H, FFH	Control Change, Channel Press, Pitch Bend, OFF

●3-2-3. Color Control Assignment

Address	Parameter Name	Sys.Ex.Value	Meaning of Value
#10H 20H 00H	V-LINK Rx Setting (Color Cb)	---	---
#10H 20H 02H	V-LINK Rx Setting (Color Cr)	---	---
#10H 20H 04H	V-LINK Rx Setting (Brightness)	---	---
#10H 20H 06H	V-LINK Rx Setting (VFX A 1)	01H-05H, 07H-1FH, 40H-5FH, DOH, E0H, FFH	Bus A Effect 1: Control Change, Channel Press, Pitch Bend, OFF
#10H 20H 08H	V-LINK Rx Setting (VFX A 2)	01H-05H, 07H-1FH, 40H-5FH, DOH, E0H, FFH	Bus A Effect 2: Control Change, Channel Press, Pitch Bend, OFF
#10H 20H 0AH	V-LINK Rx Setting (VFX A 3)	01H-05H, 07H-1FH, 40H-5FH, DOH, E0H, FFH	Bus A Effect 3: Control Change, Channel Press, Pitch Bend, OFF
#10H 20H 0CH	V-LINK Rx Setting (VFX A 4)	01H-05H, 07H-1FH, 40H-5FH, DOH, E0H, FFH	Bus A Effect 4: Control Change, Channel Press, Pitch Bend, OFF
#10H 20H 0EH	V-LINK Reserved	---	---
#10H 20H 10H	V-LINK Reserved	---	---
#10H 20H 12H	V-LINK Reserved	---	---
#10H 20H 14H	V-LINK Reserved	---	---
#10H 20H 16H	V-LINK Rx Setting (VFX B 1)	01H-05H, 07H-1FH, 40H-5FH, DOH, E0H, FFH	Bus B Effect 1: Control Change, Channel Press, Pitch Bend, OFF
#10H 20H 18H	V-LINK Rx Setting (VFX B 2)	01H-05H, 07H-1FH, 40H-5FH, DOH, E0H, FFH	Bus B Effect 2: Control Change, Channel Press, Pitch Bend, OFF
#10H 20H 1AH	V-LINK Rx Setting (VFX B 3)	01H-05H, 07H-1FH, 40H-5FH, DOH, E0H, FFH	Bus B Effect 3: Control Change, Channel Press, Pitch Bend, OFF
#10H 20H 1CH	V-LINK Rx Setting (VFX B 4)	01H-05H, 07H-1FH, 40H-5FH, DOH, E0H, FFH	Bus B Effect 4: Control Change, Channel Press, Pitch Bend, OFF
#10H 20H 1EH	V-LINK Reserved	---	---
#10H 20H 20H	V-LINK Rx Setting (Output Fader)	01H-05H, 07H-1FH, 40H-5FH, DOH, E0H, FFH	Output: Control Change, Channel Press, Pitch Bend, OFF

●3-2-4. Clip Control Preference

Address	Parameter Name	Sys.Ex.Value	Meaning of Value
10H 30H 00H	V-LINK Rx Setting (Velocity Curve Type)	---	---
10H 30H 01H	V-LINK Rx Setting (Playback Speed Control Range)	---	---
10H 30H 02H	V-LINK Rx Setting (Assignable Note Mode: Lower Key)	00H-7FH	Note Number (00H[C-1] - 7FH[G+9])
10H 30H 03H	V-LINK Rx Setting (Assignable Note Mode: Upper Key)	00H-7FH	Note Number (00H[C-1] - 7FH[G+9])

■ 3-3. V-LINK master (Model ID=00H 51H)

* These messages marked with “#” are transmitted as two bytes, with the data divided into upper byte (upper 3 bits) and lower byte (lower 7 bits).

Example) If the original data is 028AH, a value of 05H is transmitted as the first byte. A value of 0AH is transmitted as the second byte.

* If --- is shown in the value field, the V-8 does not have a corresponding parameter.

Start Address	Description
10H 00H 00H	V-LINK System Common Preference Area
20H 00H 00H	V-LINK Video System Performance Area
20H 20H 00H	V-LINK Audio Mixer Parameter Area

● 3-3-1 System Common Preference Area

Address	Parameter Name	Sys.Ex.Value	Meaning of Value
10H 00H 00H	V-LINK Enabled	00H - 01H	OFF, ON
10H 00H 01H	V-LINK MIDI Rx Channel (Clip)	---	---
10H 00H 02H	V-LINK MIDI Rx Channel (Color)	---	---
10H 00H 03H	V-LINK Note Message Enabled	---	---
10H 00H 04H	V-LINK Fast Control Enabled	---	---
10H 00H 05H	V-LINK MMC Control Mode	---	---
10H 00H 06H	V-LINK MTC Control Mode	---	---
10H 00H 07H	V-LINK Auto Mix Mode	---	---

● 3-3-2 Video System Performance Area

Address	Parameter Name	Sys.Ex.Value	Meaning of Value
20H 00H 00H	V-LINK Number of Video Mixer Inputs	---	---

● 3-3-3 Audio Mixer Parameter Area

Address	Parameter Name	Sys.Ex.Value	Meaning of Value
#20H 20H 00H	V-LINK Audio Mixer Master Level	0000H-0768H	Level 0.0 - 100.0%
#20H 21H 00H	V-LINK Audio Mixer Channel1 Level	0000H-0768H	Level 0.0 - 100.0%
#20H 21H 02H	V-LINK Audio Mixer Channel2 Level	0000H-0768H	Level 0.0 - 100.0%
#20H 21H 04H	V-LINK Audio Mixer Channel3 Level	0000H-0768H	Level 0.0 - 100.0%
#20H 21H 06H	V-LINK Audio Mixer Channel4 Level	0000H-0768H	Level 0.0 - 100.0%
#20H 21H 08H	V-LINK Audio Mixer Channel5 Level	0000H-0768H	Level 0.0 - 100.0%
#20H 21H 0AH	V-LINK Audio Mixer Channel6 Level	0000H-0768H	Level 0.0 - 100.0%
#20H 21H 0CH	V-LINK Audio Mixer Channel7 Level	0000H-0768H	Level 0.0 - 100.0%
#20H 21H 0EH	V-LINK Audio Mixer Channel8 Level	0000H-0768H	Level 0.0 - 100.0%

4. Appendices

Decimal and hexadecimal conversion table

(The letter "H" follows numbers in hexadecimal notation.)

MIDI uses hexadecimal notation in 7-bit units to indicate data values and addresses and sizes within an exclusive message. Hexadecimal and decimal numbers correspond as follows.

Deci	Hexa	Deci	Hexa	Deci	Hexa	Deci	Hexa
0	00H	32	20H	64	40H	96	60H
1	01H	33	21H	65	41H	97	61H
2	02H	34	22H	66	42H	98	62H
3	03H	35	23H	67	43H	99	63H
4	04H	36	24H	68	44H	100	64H
5	05H	37	25H	69	45H	101	65H
6	06H	38	26H	70	46H	102	66H
7	07H	39	27H	71	47H	103	67H
8	08H	40	28H	72	48H	104	68H
9	09H	41	29H	73	49H	105	69H
10	0AH	42	2AH	74	4AH	106	6AH
11	0BH	43	2BH	75	4BH	107	6BH
12	0CH	44	2CH	76	4CH	108	6CH
13	0DH	45	2DH	77	4DH	109	6DH
14	0EH	46	2EH	78	4EH	110	6EH
15	0FH	47	2FH	79	4FH	111	6FH
16	10H	48	30H	80	50H	112	70H
17	11H	49	31H	81	51H	113	71H
18	12H	50	32H	82	52H	114	72H
19	13H	51	33H	83	53H	115	73H
20	14H	52	34H	84	54H	116	74H
21	15H	53	35H	85	55H	117	75H
22	16H	54	36H	86	56H	118	76H
23	17H	55	37H	87	57H	119	77H
24	18H	56	38H	88	58H	120	78H
25	19H	57	39H	89	59H	121	79H
26	1AH	58	3AH	90	5AH	122	7AH
27	1BH	59	3BH	91	5BH	123	7BH
28	1CH	60	3CH	92	5CH	124	7CH
29	1DH	61	3DH	93	5DH	125	7DH
30	1EH	62	3EH	94	5EH	126	7EH
31	1FH	63	3FH	95	5FH	127	7FH

- * Decimal expressions used for MIDI channel, bank select, and program change are 1 greater than the decimal value shown in the above table.
- * Hexadecimal values in 7-bit units can express a maximum of 128 levels in one byte of data. If the data requires greater resolution, two or more bytes are used. For example, a value indicated by a hexadecimal expression in two 7-bit bytes "aa bb" would be "aa x 128 + bb."

<Example 1> What is the decimal equivalent of 5AH?
From the above table, 5AH = 90.

<Example 2> What is the decimal expression of the hexadecimal expression in two 7-bit bytes "12H 34H"?
From the above table, 12H = 18, and 34H = 52. Thus, 18 x 128 + 52 = 2356

Examples of MIDI messages

<Example 1> CEH 49H
CnH is the Program Change status, and n is the MIDI channel number. EH = 14, and 49H = 73. Thus, this is a Program Change message of MIDI CH= 15, program number 74 (in the GS sound map, Flute).

<Example 2> EAH 00H 28H
EnH is the Pitch Bend Change status, and n is the MIDI channel number. The second byte (00H=0) is the lower byte of the pitch bend value, and the third byte (28H=40) is the upper byte. Since the pitch bend value is a signed value with 40H 00H (= 64 x 128 + 0 = 8192) corresponding to 0, the pitch bend value in this case is:

$$28H\ 00H - 40H\ 00H = 40 \times 128 + 0 - (64 \times 128 + 0) = 5120 - 8192 = -3072$$

If the Pitch Bend Sensitivity is set to two semitones, a pitch change of -8192 (00H 00H) would change the pitch by -200 cents, so in this case, a pitch bend of -200 x (-3072) / (-8192) = -75 cents is being designated on MIDI channel 11.

Exclusive message examples and checksum calculation

Roland exclusive messages (RQ1, DT1) contain a checksum following the data (after F7), which can be used to check whether the message was received correctly. The checksum value is derived from the address and data (or size) of the transmitted exclusive message.

Calculating the checksum

('H' is appended to hexadecimal numbers)

The checksum is a value that produces a lower 7 bits of zero when the address, size, and checksum itself are summed. If the exclusive message to be transmitted has an address of aaH bbH ccH and the data is ddH eeH, the actual calculation would be as follows:

$$\begin{aligned} aa + bb + cc + dd + ee &= \text{sum} \\ \text{sum} / 128 &= \text{quotient} \dots \text{Remainder} \\ 128 - \text{remainder} &= \text{checksum} \end{aligned}$$

<Example>

Assigning Modulation as the control change that controls the transition effect time for the "Video Fader" of Tx/Rx Setting.

From the "Parameter address map," the "Video Fader" of Tx/Rx Setting has a start address of 01H 10H 0CH, and the Modulation control change has a parameter value 00H 01H. Thus,

F0H	41H	10H	00H	00H	28H	12H	01H	10H	0CH	00H	01H	??H	F7H
(1)	(2)	(3)	(4)		(5)	(6)		(7)		(8)		(9)	

- | | | |
|----------------------|------------------------|--------------------|
| (1) Exclusive status | (2) ID number (Roland) | (3) Device ID (17) |
| (4) Model ID (V-8) | (5) Command ID (DT1) | (6) Address |
| (7) Data | (8) Checksum | (9) EOX |

Next, we calculate the checksum.

$$01H + 10H + 0CH + 00H + 01H = 1 + 16 + 12 + 0 + 1 = 30 \text{ (sum)}$$

$$30 \text{ (sum)} / 128 = 0 \text{ (quotient)} \dots 30 \text{ (remainder)}$$

$$\text{Checksum} = 128 - 30 \text{ (remainder)} = 98 = 62H$$

Thus, the message to be transmitted is F0H 41H 10H 00H 00H 10H 12H 01H 10H 0CH 00H 01H 62H F7H.

Settings Transmitted/Received Using MIDI

MIDI Tx Channel

This sets the V-8's MIDI Transmit channel. The factory default setting is 1.

MIDI Rx Channel

This sets the V-8's MIDI Receive channel. The factory default setting is 1. The values 0-16 can be set via MIDI, which correspond to 1-16 and OFF.

MIDI Out/Thru Switch

This sets the MIDI OUT/THRU connector function. The factory default setting is Thru.

V-LINK Switch

This sets the V-LINK On/Off. The factory default setting is Off.

Note Mode

This setting determines whether or not the input is switched when a note on message is received.
49Keys Mode: You can switch the input with note on message of C+2 [0x24] to D+4 [0x3E].
Assign Mode: You can switch the input with note on message specified in "Note Lower Key Assign" to "Note Upper Key Assign."
The factory default setting is Off.

Note Lower Key Assign

This sets the lower limit for note numbers enabled when Note Mode is "Assign Mode."
The factory default setting is C+2 [0x24].

Note Upper Key Assign

This sets the upper limit for note numbers enabled when Note Mode is "Assign Mode."
The factory default setting is D+3* [0x35].

Device ID

This sets the ID for distinguishing devices when System Exclusive messages are received. The factory default setting is 0x10.

●Input Select A Assign

This controls the bus A INPUT SELECT buttons.
The factory default setting is CC00 + CC32 + PC.

●Input Select B Assign

This controls the bus B INPUT SELECT buttons.
The factory default setting is CC00 + CC32 + PC.

●Effect-A1 Assign

This specifies the [1 (FEEDBACK)] button on/off and the parameter.
With the factory settings this is unassigned.
Values are 0, 1–127, corresponding to Off, On: 0–Max.

●Effect-A2 Assign

This specifies the [2 (NEGATIVE)] button on/off and the parameter.
With the factory settings this is unassigned.
Values are 0, 1–127, corresponding to Off, On: 0–Max.

●Effect-A3 Assign

This specifies the [3 (COLORIZE)] button on/off and the parameter.
With the factory settings this is unassigned.
Values are 0, 1–127, corresponding to Off, On: 0–Max.

●Effect-A4 Assign

This specifies the [4 (MULTI)] button on/off and the parameter.
With the factory settings this is unassigned.
Values are 0, 1–127, corresponding to Off, On: 0–Max.

●Effect-B1 Assign

This specifies the [1 (FLIP)] button on/off and the parameter.
With the factory settings this is unassigned.
Values are 0, 1–127, corresponding to Off, On: 0–Max.

●Effect-B2 Assign

This specifies the [2 (CHROMA KEY)] button on/off and the parameter.
With the factory settings this is unassigned.
Values are 0, 1–127, corresponding to Off, On: 0–Max.

●Effect-B3 Assign

This specifies the [3 (LUMINANCE KEY)] button on/off and the parameter.
With the factory settings this is unassigned.
Values are 0, 1–127, corresponding to Off, On: 0–Max.

●Effect-B4 Assign

This specifies the [4 (P in P)] button on/off and the parameter.
With the factory settings this is unassigned.
Values are 0, 1–127, corresponding to Off, On: 0–Max.

●Fade A Switch Assign

This specifies the bus A [FADE] button on/off and the parameter.
With the factory settings this is unassigned.
Values are 0, 1–127, corresponding to Off, On: 0–Max.

●Fade B Switch Assign

This specifies the bus B [FADE] button on/off and the parameter.
With the factory settings this is unassigned.
Values are 0, 1–127, corresponding to Off, On: 0–Max.

●Control A Assign

This specifies the bus A [CONTROL] fader output.
With the factory settings this is unassigned.
Values are 0–127, corresponding to 0–Max.
* Transmit only.

●Control B Assign

This specifies the bus B [CONTROL] fader output.
With the factory settings this is unassigned.
Values are 0–127, corresponding to 0–Max.
* Transmit only.

●Video Fader Assign

Controls the VIDEO FADER.
The factory default setting is CC11.
Values are 0–127, corresponding to bus A–bus B.

●Transition Assign

This selects the TRANSITION buttons.
With the factory settings this is unassigned.
Values are 0–2, corresponding to the [1 MIX], [2 WIPE], and [3 EFX] button.

●Transformer A Assign

This specifies the bus A [TRANSFORMER] button on/off.
With the factory settings this is unassigned.
Values are 0–63 and 64–127, corresponding to OFF and ON.

●Transformer B Assign

This specifies the bus B [TRANSFORMER] button on/off.
With the factory settings this is unassigned.
Values are 0–63 and 64–127, corresponding to OFF and ON.

●BPM SYNC Assign

Switches BPM SYNC on/off.
With the factory settings this is unassigned.
Values are 0–63 and 64–127, corresponding to OFF and ON.

●Transition Time Assign

This specifies image switching time.
The factory default setting is CC07 (Volume).
Values are 0–127, corresponding to 0.0 sec–4.0 sec.

●BPM/CONTROL Assign

Controls the [BPM/CONTROL] knob.
The factory default setting is OFF.
* Transmit only.

●Output Fade Assign

Controls the [OUTPUT FADE] fader.
The factory default setting is OFF.
Values are 0–127, corresponding to fade 0%–100%.

●White/Black Assign

Controls the [WHITE/BLACK] switch.
The factory default setting is OFF.
Values are 0–63 and 64–127, corresponding to BLACK and WHITE.

●PC Input Select Assign

Controls the [PC INPUT SELECT] switch.
The factory default setting is OFF.
Values are 0 and 1, corresponding to PC1 and PC2.

●Preview Output Assign

Controls the PREVIEW OUTPUT SELECT buttons.
The factory default setting is OFF.
Values are 0–1, corresponding to the PREVIEW OUTPUT SELECT [1]–[OUTPUT] buttons.

●Memory Assign

Controls the [MEMORY] knob.
The factory default setting is CC00 + CC32 + PC.
Values are 0–7, corresponding to memory number 1–8.

■Factory Setting of V-LINK

The factory setting of V-LINK (receipt of V-LINK ON message only) is as follows.

Parameter	Assign	Value
Rx Channel	-	1
Tx Channel	-	1
Note Mode	-	OFF
Input Select A Assign	CC00 + CC32 + PC	Bus A: 1
Input Select B Assign	CC00 + CC32 + PC	Bus B: 2
Effect-A1 Assign	OFF	OFF
Effect-A2 Assign	OFF	OFF
Effect-A3 Assign	OFF	OFF
Effect-A4 Assign	OFF	OFF
Effect-B1 Assign	OFF	OFF
Effect-B2 Assign	OFF	OFF
Effect-B3 Assign	OFF	OFF
Effect-B4 Assign	OFF	OFF
FADE A Switch Assign	OFF	OFF
FADE B Switch Assign	OFF	OFF
Control A Assign	OFF	OFF
Control B Assign	OFF	OFF
Video Fader Assign	CC11 (Expression)	Bus A 100%
Transition Assign	OFF	1
Transformer A Assign	OFF	OFF
Transformer B Assign	OFF	OFF
BPM/Sync Assign	OFF	OFF
Transition Time Assign	CC05 (Portamento Time)	0.0sec
BPM CONTROL Assign	OFF	OFF
Output Fade Assign	OFF	MAX
White/Black Assign	OFF	Black
PC Input Select Assign	OFF	OFF
Preview Output Assign	OFF	OFF
Memory Assign	CC00 + CC32 + PC	1

* When V-LINK is off, V-LINK message will be ignored.

* The changes of setting done while V-LINK is on will not be saved.

* When switching from V-LINK ON to OFF, the MIDI transmit/receive settings revert to the settings that were in effect before V-LINK was switched on.

MIDI Implementation Chart

Model: V-8

Date : Jan. 10, 2008

Version : 1.00

Function...	Transmitted	Recognized	Remarks
Basic Channel Default Changed	1 1-16	1 1-16	
Mode Default Messages Altered	Mode 3 X *****	Mode 3 X *****	
Note Number : True Voice	X X	O X	Operational only when Note Mode is 49Keys Assign or Assign Mode
Velocity Note ON Note OFF	X X	X X	
After Touch Key's Ch's	X O	X O	Control various parameters
Pitch Bend	O	O	Control various parameters
Control Change 0,32 1-5 7-31 64-95	O O O O	O O O O	Select A/B INPUT, Select MEMORY Control various parameters Control various parameters Control various parameters
Program Change : True #	O 0-7	O 0-7	Select A/B INPUT: 1-8 Select MEMORY: 1-8
System Exclusive Common :Song Pos :Song Sel :Tune	O X X X	O X X X	Set parameters, V-LINK
Real-Time :Clock :Commands	X X	O O	Start, Continue
Others :All sound OFF :Reset all controller :Local ON/OFF :All Notes OFF :Active Sense :Reset	X X X X O X	X X X X O X	
Notes			

Mode 1 : OMNI ON, POLY Mode 2 : OMNI ON, MONO
Mode 3 : OMNI OFF, POLY Mode 4 : OMNI OFF, MONO

O : Yes
X : No

Transition Effect List

Dissolve Transition

The effect gradually blends the image into another.

- 001: Mix01
- 002: Fam01
- 003: Fam*
- 004: Nam01
- 005: Nam*



* For details on the effects, refer to "About the FAM and NAM Transition Effects" (p. 37).

Wipe Transition

The effect like windshield wiper on a car. The present image is wiped off as it changes to another.

Herd Edge Type

006: Wipe01



007: Wipe02



008: Wipe03



009: Wipe04



010: Wipe05

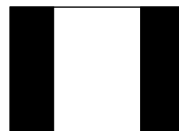

011: Wipe06

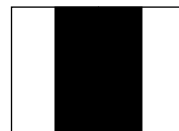

012: Wipe07



013: Wipe08

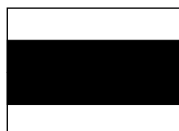

014: Wipe09



015: Wipe10

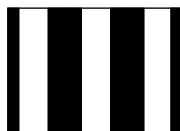

016: Wipe11

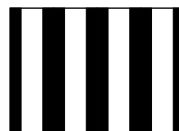

017: Wipe12

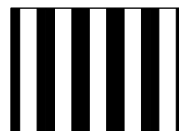

018: Wipe13

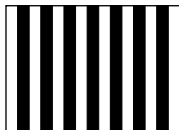

019: Wipe14

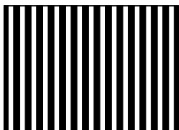

020: Wipe15

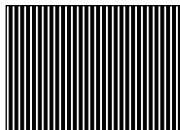

021: Wipe16

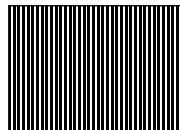

022: Wipe17



023: Wipe18



024: Wipe19



025: Wipe20



026: Wipe21

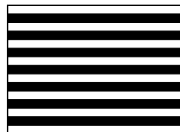

027: Wipe22

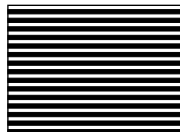

028: Wipe23

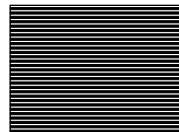

029: Wipe24

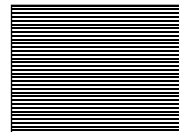

030: Wipe25



031: Wipe26



032: Wipe27



033: Wipe28



034: Wipe29



035: Wipe30



036: Wipe31



037: Wipe32



038: Wipe33



039: Wipe34



040: Wipe35



041: Wipe36



042: Wipe37

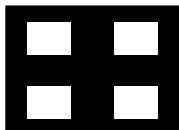

043: Wipe38

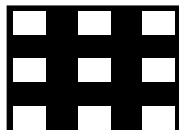

044: Wipe39

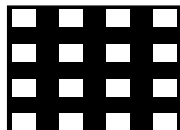

045: Wipe40

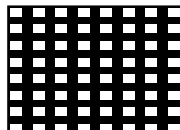

046: Wipe41

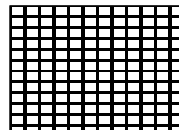

047: Wipe42

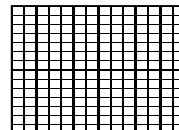

048: Wipe43

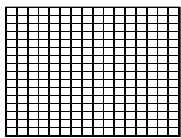

049: Wipe44

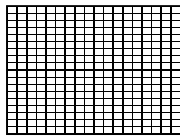

050: Wipe45

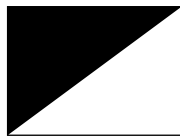

051: Wipe46

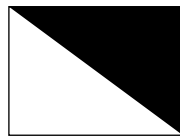

052: Wipe47

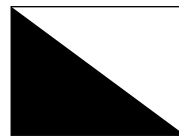

053: Wipe48

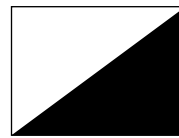

054: Wipe49

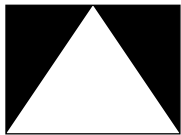

055: Wipe50

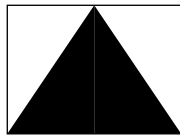

056: Wipe51

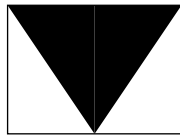

057: Wipe52

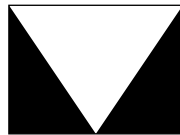

058: Wipe53

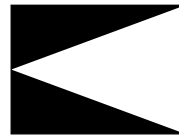

059: Wipe54

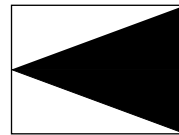

060: Wipe55

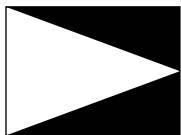

061: Wipe56

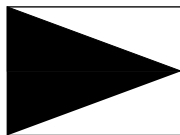

062: Wipe57

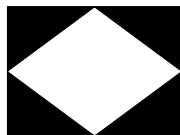

063: Wipe58

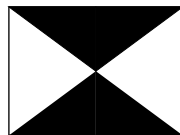

064: Wipe59

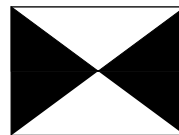

065: Wipe60

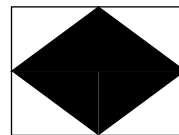

066: Wipe61

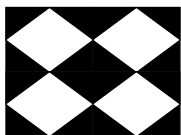

067: Wipe62



068: Wipe63

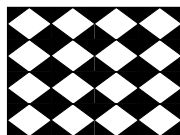

069: Wipe64

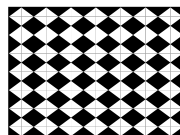

070: Wipe65

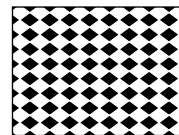

071: Wipe66

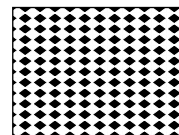

072: Wipe67

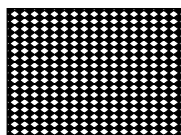

073: Wipe68

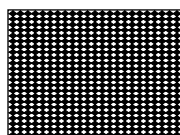

074: Wipe69



075: Wipe70



076: Wipe71



077: Wipe72

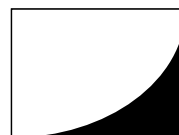

078: Wipe73

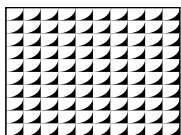

079: Wipe74

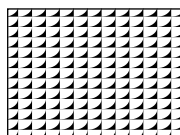

080: Wipe75

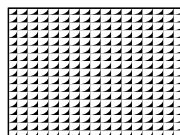

081: Wipe76

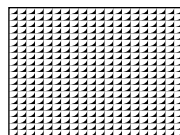

082: Wipe77

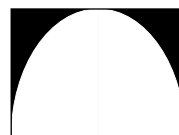

083: Wipe78

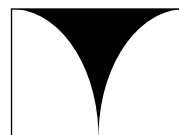

084: Wipe79

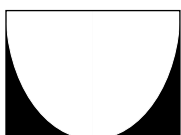

085: Wipe80

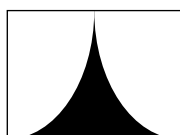

086: Wipe81



087: Wipe82



088: Wipe83

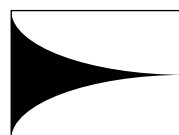

089: Wipe84

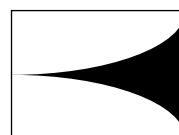

090: Wipe85

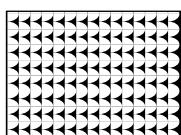

091: Wipe86

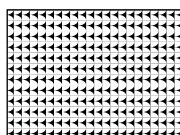

092: Wipe87

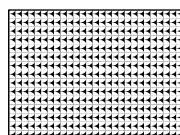

093: Wipe88

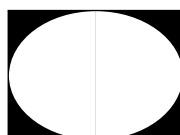

094: Wipe89

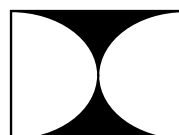

095: Wipe90

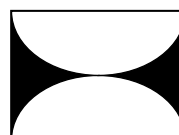

096: Wipe91

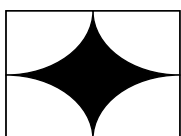

097: Wipe92

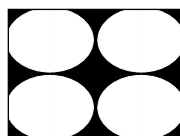

098: Wipe93

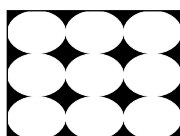

099: Wipe94

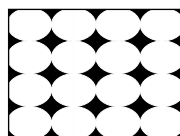

100: Wipe95

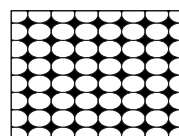

101: Wipe96

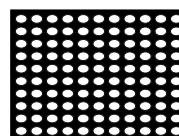

102: Wipe97

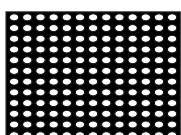

103: Wipe98

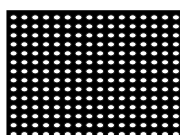

104: Wipe99



Soft Edge Type

105: SWipe01



106: SWipe02



107: SWipe03



108: SWipe04



109: SWipe05



110: SWipe06



111: SWipe07



112: SWipe08



113: SWipe09



114: SWipe10



115: SWipe11



116: SWipe12



117: SWipe13

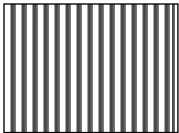

118: SWipe14

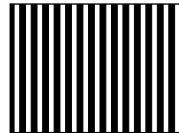

119: SWipe15

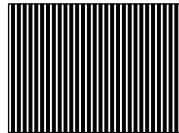

120: SWipe16

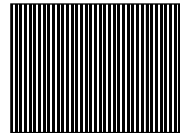

121: SWipe17



122: SWipe18

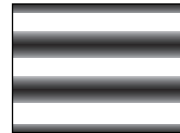

123: SWipe19



124: SWipe20

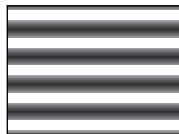

125: SWipe21

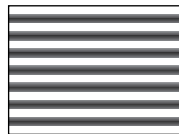

126: SWipe22

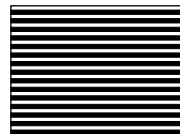

127: SWipe23

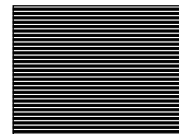

128: SWipe24

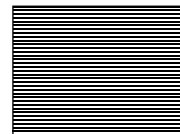

129: SWipe25



130: SWipe26



131: SWipe27



132: SWipe28



133: SWipe29



134: SWipe30



135: SWipe31



136: SWipe32



137: SWipe33



138: SWipe34



139: SWipe35



140: SWipe36



141: SWipe37



142: SWipe38

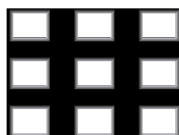

143: SWipe39

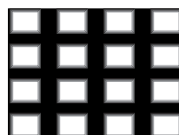

144: SWipe40

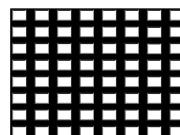

145: SWipe41

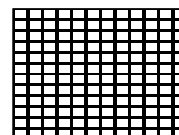

146: SWipe42

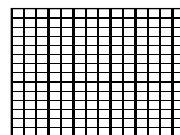

147: SWipe43

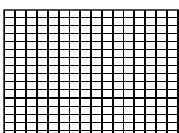

148: SWipe44

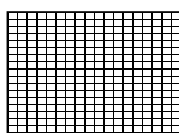

149: SWipe45



150: SWipe46

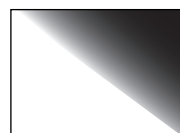

151: SWipe47

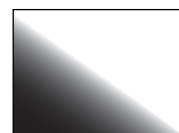

152: SWipe48

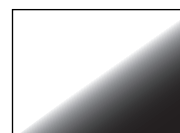

153: SWipe49



154: SWipe50

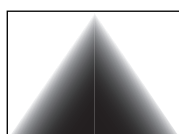

155: SWipe51

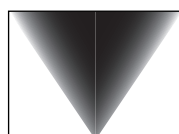

156: SWipe52

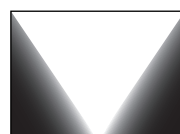

157: SWipe53

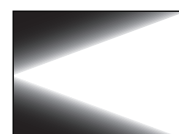

158: SWipe54

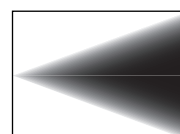

159: SWipe55



160: SWipe56

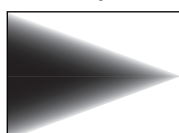

161: SWipe57

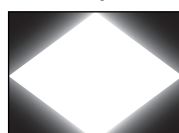

162: SWipe58



163: SWipe59

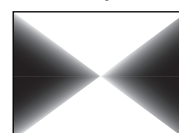

164: SWipe60

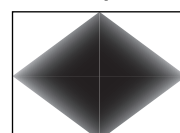

165: SWipe61

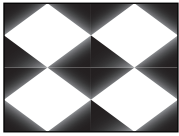

166: SWipe62

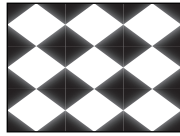

167: SWipe63

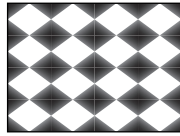

168: SWipe64

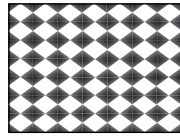

169: SWipe65

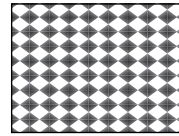

170: SWipe66

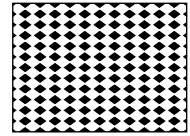

171: SWipe67

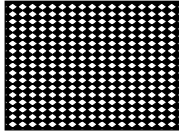

172: SWipe68

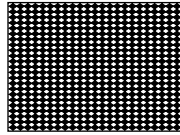

173: SWipe69

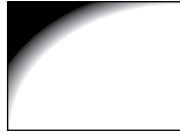

174: SWipe70



175: SWipe71



176: SWipe72

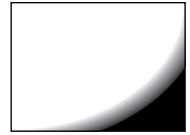

177: SWipe73

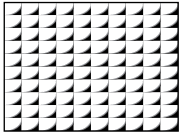

178: SWipe74

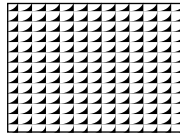

179: SWipe75

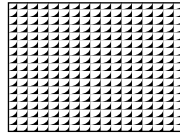

180: SWipe76

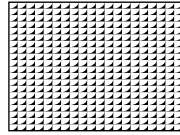

181: SWipe77

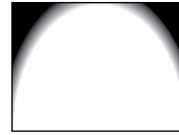

182: SWipe78

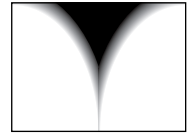

183: SWipe79

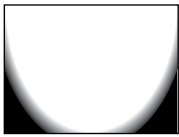

184: SWipe80

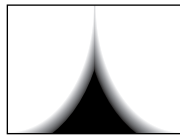

185: SWipe81

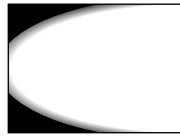

186: SWipe82



187: SWipe83

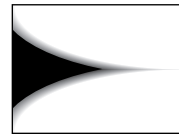

188: SWipe84

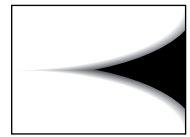

189: SWipe85

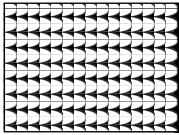

190: SWipe86

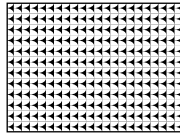

191: SWipe87

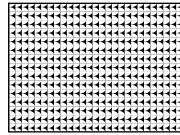

192: SWipe88

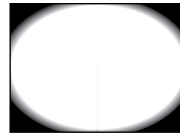

193: SWipe89

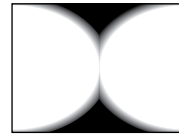

194: SWipe90

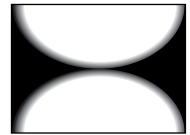

195: SWipe91

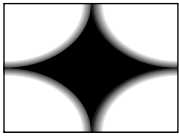

196: SWipe92

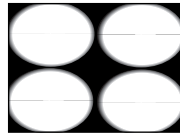

197: SWipe93

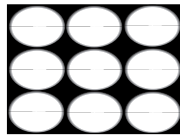

198: SWipe94

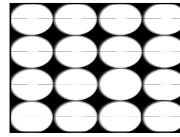

199: SWipe95

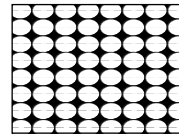

200: SWipe96

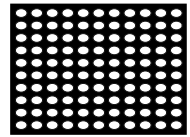

201: SWipe97

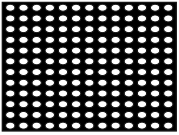

202: SWipe98

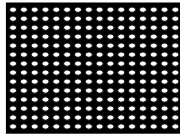

203: SWipe99

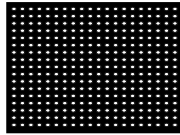

Key Transition

The bright or dark part of present image gradually changes to another.

204: Key01



The dark part of bus B image gradually changes to bus A image.

205: Key02



The bright part of bus A image gradually changes to bus B image.

206: Key03



The bright part of bus B image gradually changes to bus A image.

207: Key04



The dark part of bus A image gradually changes to bus B image.

Slide Transition

The effect to slide out the present image and slide in the another.

Normal Type

208: Slide01

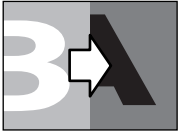

209: Slide02



210: Slide03

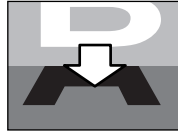

211: Slide04



212: Slide05



213: Slide06



214: Slide07



215: Slide08



216: Slide09



217: Slide10



218: Slide11



219: Slide12



220: Slide13



221: Slide14



222: Slide15

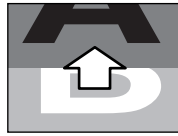

223: Slide16



224: Slide17

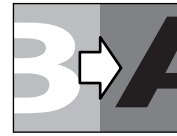

225: Slide18



226: Slide19



227: Slide20

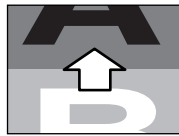

Sequence Type

228: Slide21



1. A → B

228: Slide22



2. B → A

228: Slide22



1. A → B

228: Slide22



2. B → A

230: Slide23



1. A → B

230: Slide23

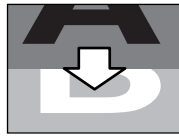

2. B → A

231: Slide24

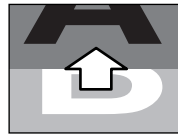

1. A → B

231: Slide24



2. B → A

232: Slide25



1. A → B

232: Slide25

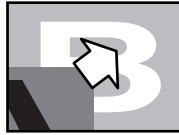

2. B → A

232: Slide25



3. A → B

232: Slide25



4. B → A

233: Slide26



1. A → B

233: Slide26



2. B → A

233: Slide26

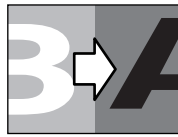

3. A → B

233: Slide26



4. B → A

Stretch Transition

This transition stretches the new image across the previous image.



User Transition

Eight transition effects can be combined to create an original transition pattern. For details, refer to “Combining Multiple Transition Effects (User Transition)” (p. 38).

- 260: User01** Wipe94 → Wipe91 → Wipe89 → Wipe88 → Wipe90 → Wipe92 → Wipe93 → Wipe94
- 261: User02** Wipe05 → Wipe06 → Wipe09 → Wipe10 → Wipe12 → Wipe13 → Wipe14 → Wipe16
- 262: User03** Wipe49 → Wipe55 → Wipe52 → Wipe53 → Wipe49 → Wipe55 → Wipe52 → Wipe53
- 263: User04** Wipe87 → Wipe76 → Wipe99 → Wipe44 → Wipe24 → Wipe68 → Wipe24 → Wipe87

(Factory settings)

Effect List

No.	Effect name	Explanation
001:	STILL1	Field Frieze *1
002:	STILL2	Frame Frieze *1
003:	STROBE1	Strobe
:	:	
011:	STROBE9	
012:	STROBE*	
013:	AFTERIMAGE1	Afterimage (residual effect)
:	:	
016:	AFTERIMAGE4	
017:	AFTERIMAGE*	
018:	FEEDBACK1	Repeatedly layer the image onto itself
:	:	
021:	FEEDBACK4	
022:	FEEDBACK*	
023:	SHAKE1*	Shake
:	:	
028:	SHAKE6*	
029:	NOSYNC	Image with faulty synchronization
030:	NEGATIVE1	Negative (invert brightness and color)
:	:	
032:	NEGATIVE3	
033:	NEGATIVE*	
034:	COLORIZE1	Colorize (add color to the image)
:	:	
041:	COLORIZE8	
042:	COLORIZE*	
043:	FINEDGE1	Extract outlines
:	:	
050:	FINEDGE8	
051:	FINEDGE*	
052:	SILHOUETTE1	Divide image into light and dark areas, blacken the dark areas and apply a different color to the light areas *2
:	:	
059:	SILHOUETTE8	
060:	SILHOUETTE*	
061:	MONOCOLOR1	Single-color filter
:	:	
068:	MONOCOLOR8	
069:	MONOCOLOR*	
070:	EMBOSS1	Emboss (bas-relief image)
:	:	
077:	EMBOSS8	
078:	EMBOSS*	
079:	POSTERIZE1	Posterize (modify the gradations of brightness)
:	:	
082:	POSTERIZE4	
083:	POSTERIZE*	

No.	Effects name	Explanation
084:	COLORPASS1	Make monochrome while leaving a specific color (color pass)
:	:	
091:	COLORPASS8	
092:	COLORPASS*	
093:	W-LUMIKEY	Luminance key (extract white)
094:	W-LUMIKEY*	
095:	B-LUMIKEY	Luminance key (extract black)
096:	B-LUMIKEY*	
097:	CHROMAKEY	Chroma key
098:	CHROMAKEY*	
099:	FLIP-H	Flip image (Flip left/right: FLIP-H, Flip top/bottom: FLIP-V, Flip top/bottom/left/right: FLIP-HV)
100:	FLIP-V	
101:	FLIP-HV	
102:	FLIP*	
103:	MULTI-H1	Multi-screen divided vertically
:	:	
109:	MULTI-H7	
110:	MULTI-H*	
111:	MULTI-V1	Multi-screen divided horizontally
:	:	
117:	MULTI-V7	
118:	MULTI-V*	
119:	MULTI-HV1	Multi-screen divided vertically and horizontally
:	:	
125:	MULTI-HV7	
126:	MULTI-HV*	
127:	MIRROR-H1	Divide the image vertically and mirror it
:	:	
130:	MIRROR-H4	
131:	MIRROR-H*	
132:	MIRROR-V1	Divide the image horizontally and mirror it
:	:	
135:	MIRROR-V4	
136:	MIRROR-V*	
137:	MIRROR-HV1	Divide the image vertically and horizontally, and mirror it
:	:	
140:	MIRROR-HV4	
141:	MIRROR-HV*	
142:	PinP1	Picture In Picture
:	:	
149:	PinP8	
150:	PinP*	

*1 If the image is fast-moving, using field freeze (STILL1) will produce a less blurry still image.
If the image has little movement, using frame freeze (STILL2) will produce a clear still image.

*2 The threshold value between the dark area and light area can be adjusted by the "Key Setup" menu item "Silhouette Level."

Effects that Can Be Controlled by the [CONTROL] Fader

If you've assigned an effect that has an "*" (asterisk) following its effect name, you can use the [CONTROL] fader to modify the following settings. The EFFECTS button whose settings can be modified will blink (p. 42).

No.	Effect name	Setting controlled by the [CONTROL] fader
012:	STROBE*	Change the spacing at which the still images will be output (nine levels).
017:	AFTERIMAGE*	Change the time that the afterimage is shown (four levels).
022:	FEEDBACK*	Change the strength of the effect over four levels.
023:	SHAKE1*	Adjusts the speed at which the image will shake.
:	:	
028:	SHAKE6*	
033:	NEGATIVE*	Change the portion that is inverted ("Invert brightness and color," "Invert color," "Invert brightness").
042:	COLORIZE*	Change the colorization pattern (eight types).
051:	FINEDGE*	Smoothly changes the color of the outline edge and background.
060:	SILHOUETTE*	Smoothly changes the color applied to the image.
069:	MONOCOLOR*	Smoothly changes the color of the color filter.
078:	EMBOSS*	Smoothly changes the color applied to the image.
083:	POSTERIZE*	Change the strength of the effect (four levels).
092:	COLORPASS*	Change the color that remains (eight types).
094:	W-LUMIKEY*	Change the white luminance level.
096:	B-LUMIKEY*	Change the black luminance level.
098:	CHROMAKEY*	Change the chromakey level.
102:	FLIP*	Change the direction in which the image is flipped ("Flip left/right/top/bottom," "Flip top/bottom," "Flip left/right").
110:	MULTI-H*	Change the pattern by which the image is divided vertically (seven types).
118:	MULTI-V*	Change the pattern by which the image is divided horizontally (seven types).
126:	MULTI-HV*	Change the pattern by which the image is divided horizontally and vertically (seven types).
131:	MIRROR-H*	Change the pattern by which the image is divided vertically (four types).
136:	MIRROR-V*	Change the pattern by which the image is divided horizontally (four types).
141:	MIRROR-HV*	Change the pattern by which the image is divided horizontally and vertically (four types).
150:	PinP*	Changes the position (eight types) of the subscreen. The position of the subscreen will reflect the "142: PinP1"–"149: PinP8" settings (p. 44).

Effects that Cannot Be Used Simultaneously

For effects that cannot be used simultaneously, the effect name in the information about the settings (p. 26) is shown as “- - - - -”.

● Combinations of a transition and an effect

Name of transition	Effect name that cannot be used simultaneously						
Key	SILHOUETTE	W-LUMIKEY	B-LUMIKEY	CHROMAKEY			
Slide	SILHOUETTE MIRROR	SHAKE	W-LUMIKEY	B-LUMIKEY	CHROMAKEY	FLIP	MULTI
Stretch	STILL MIRROR	STROBE PinP	W-LUMIKEY	B-LUMIKEY	CHROMAKEY	FLIP	MULTI

Effect name	Transition effect name that cannot be used simultaneously						
PinP	Fam User	Nam	Wipe	SWipe	Key	Slide	Stretch

* When “PinP” is turned on, the transition effect will temporarily change to “Mix” for all TRANSITION buttons.

● Combining effects

Effect name	Effect name that cannot be used simultaneously						
STILL	STILL MULTI	STROBE PinP	AFTERIMAGE	FEEDBACK	NOSYNC	FINDEDGE	EMBOSS
STROBE	STILL	STROBE	NOSYNC	FINDEDGE	EMBOSS	MULTI	PinP
AFTERIMAGE	AFTERIMAGE	FEEDBACK *1	SILHOUETTE	W-LUMIKEY	B-LUMIKEY	CHROMAKEY	PinP
FEEDBACK	AFTERIMAGE *2	FEEDBACK	SILHOUETTE	W-LUMIKEY	B-LUMIKEY	CHROMAKEY	PinP
SHAKE	SHAKE	FLIP	MULTI	MIRROR	PinP		
NOSYNC	NOSYNC						
NEGATIVE							
COLORIZE	NEGATIVE COLORPASS	COLORIZE	FINDEDGE	SILHOUETTE	MONOCOLOR	EMBOSS	POSTERIZE
FINDEDGE							
SILHOUETTE	AFTERIMAGE EMBOSS	FEEDBACK POSTERIZE	NEGATIVE COLORPASS	COLORIZE W-LUMIKEY	FINDEDGE B-LUMIKEY	SILHOUETTE CHROMAKEY	MONOCOLOR PinP
MONOCOLOR							
EMBOSS	NEGATIVE COLORPASS	COLORIZE	FINDEDGE	SILHOUETTE	MONOCOLOR	EMBOSS	POSTERIZE
POSTERIZE							
COLORPASS							
W-LUMIKEY							
B-LUMIKEY	AFTERIMAGE	FEEDBACK	SILHOUETTE	W-LUMIKEY	B-LUMIKEY	CHROMAKEY	
CHROMAKEY							
FLIP	SHAKE	FLIP	MULTI	MIRROR	PinP	STILL *3	STROBE *3
MULTI	SHAKE	FLIP	MULTI	MIRROR	PinP	STILL *4	STROBE *4
MIRROR	SHAKE	FLIP	MULTI	MIRROR	PinP	STILL *5	STROBE *5
PinP	AFTERIMAGE PinP	FEEDBACK STILL *6	SHAKE STROBE *6	SILHOUETTE	FLIP	MULTI	MIRROR

*1 “AFTERIMAGE” takes priority for both bus A and bus B.

*2 “FEEDBACK” takes priority for both bus A and bus B.

3 When “FLIP” is on, “STILL” or “STROBE” will turn off when you operate the [CONTROL] fader.

4 When “MULTI-H”, “MULTI-V*”, or “MULTI-HV*” are on, “STILL” or “STROBE” will turn off when you operate the [CONTROL] fader.

5 When “MIRROR-H”, “MIRROR-V*”, or “MIRROR-HV*” are on, “STILL” or “STROBE” will turn off when you operate the [CONTROL] fader.

6 When “PinP” is on, “STILL” or “STROBE” will turn off when you operate the [CONTROL] fader.

Block Diagram

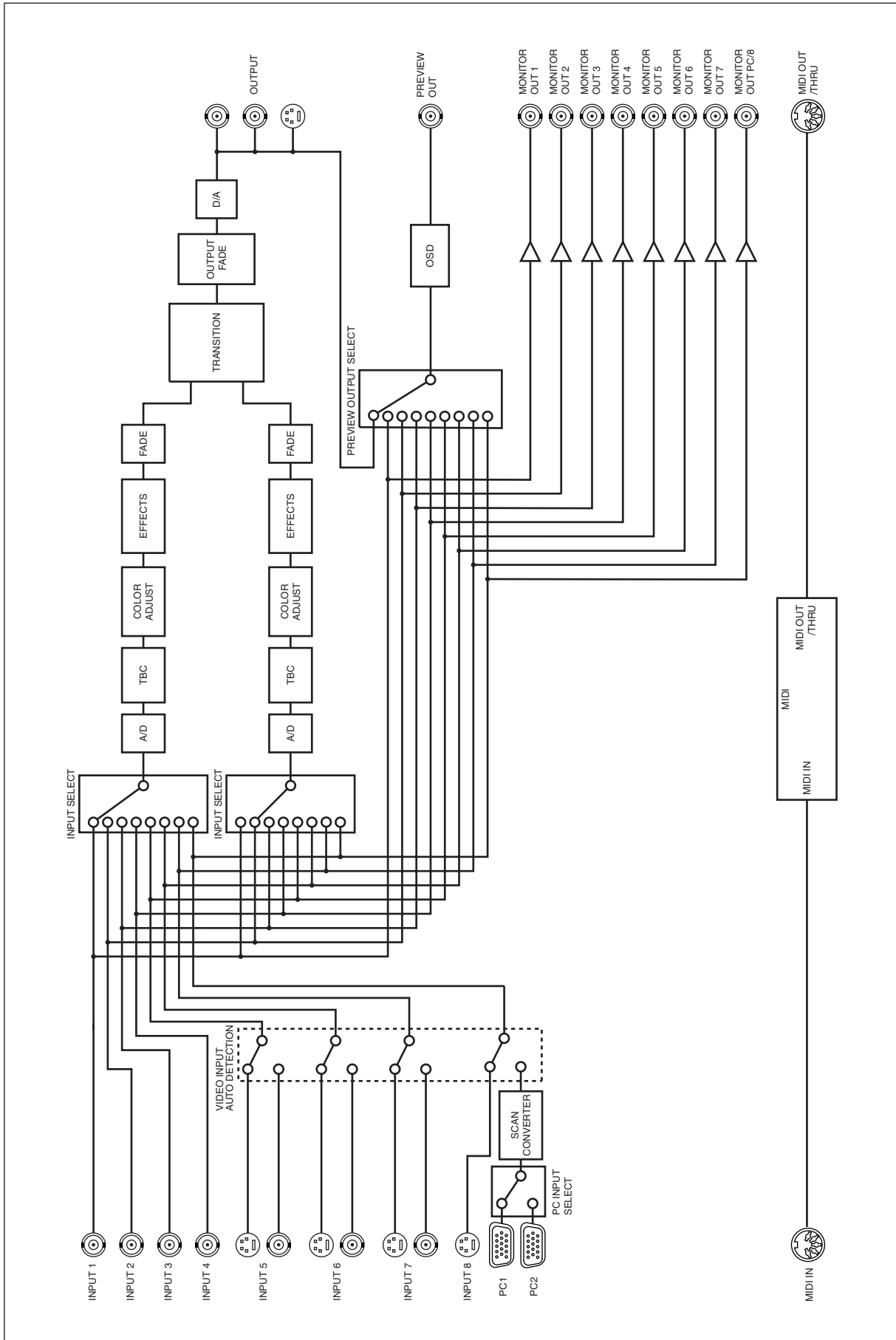

Main Specifications

V-8: 8-Channel Video Mixer

Video Format	Video	NTSC or PAL (ITU601)
	PC-RGB	640x480/120 Hz, 800x600/120 Hz, 832x624/75 Hz, 1024x768/80 Hz, 1152x864/80 Hz, 1152x870/75 Hz, 1280x1024/75 Hz, 1600x1200/60 Hz (RGB VH: positive/negative logic) * VESA DMT Version 1.0 Revision 10 conform. * The refresh rate is the maximum value of each resolution.
Video Sampling Rate	Video	4:2:2 (Y:B-Y:R-Y), 8 bits, 13.5 MHz
Frame Synchronizer		2 systems
Input Level and Impedance	Video (composite)	1.0 Vp-p, 75 ohms
	S-video	Luminance signal: 1.0 Vp-p, 75 ohms Chrominance signal: 0.286 mVp-p, 75 ohms (NTSC) / 0.3 mVp-p, 75 ohms (PAL)
	PC-RGB	0.7 Vp-p, 75 ohms (H, V: 5 V TTL)
Output Level and Impedance	Video (composite)	1.0 Vp-p, 75 ohms
	S-video	Luminance signal: 1.0 Vp-p, 75 ohms Chrominance signal: 0.286 mVp-p, 75 ohms (NTSC) / 0.3 mVp-p, 75 ohms (PAL)
Connectors	Input	Video (composite): BNC type x 7 jacks (Ch 1–7)
		S-video: 4-pin mini DIN type x 4 jacks (Ch 5–8)
		PC-RGB: D-SUB 15pin Shrink Type x 2 jacks (Ch 8: PC1 / PC2) * Inputs 5–8; however if S-video is simultaneously input to 5–8, S-video takes priority
	Output	Video (composite): BNC type x 2 jacks
		S-video: 4-pin mini DIN type x 1 jacks
	Preview Output	Video (composite): BNC type x 1 jack (OSD Menu)
Monitor Output	Video (composite): BNC type x 8 jacks (Ch 1–8)	
Remote Control Interfaces	MIDI IN	5-pin DIN type x 1 jack
	MIDI OUT/THRU	5-pin DIN type x 1 jack
Transition effects		Mix: Dissolve, Nam, Fam Wipe: Hard edge wipe, Soft edge wipe Key, Slide, Stretch, User Transition (more than 200 types)
Video effects		Still, Strobe, Afterimage, Feedback, Shake, Negative, Colorize, Finedge, Silhouette, Monocolor, Emboss, Posterize, Colorpass, Luminance key, Chroma key, Flip, Multi, Mirror, Picture-in-picture
Power Supply		DC 9 V (AC Adaptor: PSB-1U)
Current Draw		2A (AC Adaptor: PSB-1U)
Dimensions		238 (W) x 315 (D) x 134 (H) mm
		9-3/8 (W) x 12-7/16 (D) x 5-5/16 (H) inches
Weight		3.2 kg
		7 lbs 1 oz
Accessories		AC Adaptor (PSB-1U) Power cord BNC to RCA video adapter x 4 Mount screw for video fader x 4 Owner's Manual
Options		Crossfader: V-4CF

* In the interest of product improvement, the specifications and/or appearance of this unit are subject to change without prior notice.

Index

Symbols

[▲][▼] buttons 10, 24

Numerics

1. Mix (Trans1) 36
2. Wipe (Trans2) 36
3. Efx (Trans3) 36

A

AC adaptor connector 13
Adjusting the input image
 Bus A / bus B 56
 PC input image 54
Auto Detect 55

B

Blue back output 21
[BPM/CONTROL] knob 10, 37, 60
BPM display 10, 37, 60, 61
BPM SYNC 62
BPM sync 60, 61
[BPM SYNC] button 11, 60, 61, 62
Bulk dump 69, 71
Bus A / bus B 9

C

Calibrating 77
Chroma key 45
Color Bar Out 58
Color bars 58
Combining images
 Chroma key 45
 Luminance key 46
 Picture in picture 43
Connecting 14
[CONTROL] fader 11, 12, 31, 42
Cord hook 13, 15
Cross point 37

E

Effects
 About effects 42
 Chroma key 45
 Colorize 49
 [CONTROL] faders 42
 EFFECTS buttons 53

Effects (continued)

 Feedback 50
 Flip 52
 List 105
 Luminance key 46
 Multi-screen 51
 Negative 48
 Picture in picture 43
Effects-A 53
Effects-B 53
EFFECTS buttons 11, 12, 53
[ENTER] button 10, 24

F

Factory Reset 33
Factory reset
 All settings 33
 Sub-menu settings 34
[FADE] button 11, 12, 31
Fade level 32
Fading out
 Bus A / bus B 31
 Final output 32
FAM transition 37
Final output image 21

G

Ground terminal 13, 15

I

INPUT connectors 13
Input resolution 55
INPUT SELECT buttons 10, 12, 35

L

Local off 67
Luminance key 46

M

Memory
 Copying 29
 Exchanging 30
 Factory preset 28
 [MEMORY] knob 28
 Recalling 29
 Stored setting 28

Memory Edit	29, 30
[MEMORY] knob	10, 28
Memory Protect	25
Menu	
Adjusting the menu display position	25
Current settings display	26
Factory reset	33
List	81
Locking (Memory protect)	25
Operating	24
Saving	25
[MENU] button	10, 24
MIDI Bulk Dump	69, 71
MIDI implementation	90
MIDI implementation chart	98
MIDI IN connector	13
MIDI message	
Reception settings	68
Transmission on/off	67
Transmission settings	66
MIDI OUT/THRU connector	13, 66
MIDI Out/Thru Switch	66
MIDI Rx Channel	68
MIDI Tx Channel	66
MONITOR OUT connectors	13
MONITOR OUT PC/8 connector	13
Multi-screen	51

N

NAM transition	37
No Signal Blueback	21
Note message	68
Note Mode	68
NTSC/PAL	59
NTSC format	59

O

OSD Horizontal Locate	25
OSD Vertical Locate	25
OutFade Black Level	32
OutFade White Level	32
OUTPUT connectors	13
Output Fade	32
[OUTPUT FADE] fader	11, 32
Outputting	
Adjusting the output image	57
Final output image	21
Preview image	22

P

PAL format	59
Panel Mode	67
[PC INPUT SELECT] switch	11, 21, 35, 54
PC Input Setup	54
Picture in picture	43
P in P	43
Power on/off	20
[POWER] switch	13, 20
PR Control	75
PR control mode	75
Preview Display Mode	27
Preview image	22
PREVIEW OUT connector	13
PREVIEW OUTPUT SELECT buttons	11, 22
Preview Signal Check	22
Preview Switch Pattern	22
Protect On	25

R

Reset	34
Resolution	55

S

Security slot	13
Settings display	26, 27
Signal flow	9
Switching	39
Switching images	
BPM sync	60, 61
INPUT SELECT buttons	35
[TRANSFORMER] button	40
Transition effect	35, 36
Video fader	35

T

[TAP] button	10, 61
Tearing	55
Transformer-A	41
Transformer-B	41
[TRANSFORMER] button	11, 12, 40, 41
TRANSITION buttons	11, 35, 36
Transition effect	
[BPM/CONTROL] knob	37
FAM/NAM	37
List	99
Selecting	35
TRANSITION buttons	35, 36
User transition	38

U

User transition	38
Switching function	39

V

Video fader	
Calibrating	77
Installing	76
Operating curve	78
Operating modes	78
Video Fader Calibrate A	77
Video Fader Calibrate B	77
Video Fader Curve	78
Video Fader Mode	78
Video signal flow	9
V-LINK	72

W

[WHITE/BLACK] switch	11, 32
----------------------------	--------

Information

When you need repair service, call your nearest EDIROL/Roland Service Center or authorized EDIROL/Roland distributor in your country as shown below.

ASIA

INDONESIA

PT. Citra IntiRama
JL. Cideng Timur No. 15J-15O
Jakarta Pusat
INDONESIA
TEL: (021) 632-4170

CHINA

Roland Shanghai Electronics Co.,Ltd.
5F. No.1500 Pingliang Road
Shanghai 200090, CHINA
TEL: (021) 5580-0800

Roland Shanghai Electronics Co.,Ltd.
(BEIJING OFFICE)
10F. No.18 3 Section Anhuaxili
Chaoyang District Beijing
100011 CHINA
TEL: (010) 6426-5050

KOREA

KOREA AVICS CO., LTD.
463-3 Sunghwa bldg, 3rd F.,
Seokyo-Dong, Mapo-ku,
Seoul, KOREA
Tel: 02-322-3264

TAIWAN

ROLAND TAIWAN
ENTERPRISE CO., LTD.
Room 5, 9fl. No. 112 Chung Shan
N.Road Sec.2, Taipei, TAIWAN,
R.O.C.
TEL: (02) 2561 3339

SINGAPORE/ MALAYSIA

Roland Asia Pacific Sdn. Bhd.
45-1, Block C2, Jalan PJU 1/39,
Dataran Prima, 47301 Petaling
Jaya, Selangor, MALAYSIA
TEL: 3-7805-3263

CENTRAL/LATIN AMERICA

BRAZIL

Roland Brasil Ltda.
Rua San Jose, 780 Sala B
Parque Industrial San Jose
Cotia - Sao Paulo - SP, BRAZIL
TEL: (011) 4615 5666

Other CENTRAL/ LATIN AMERICA

Roland Systems Group U.S.
425 Sequoia Drive Suite 114,
Bellingham, Washington,
98226 USA
TEL: 360-594-4282

EUROPE

AUSTRIA/GERMANY/ ITALY/IRELAND/ UNITED KINGDOM

EDIROL (Europe) Ltd.
Studio 3.4 114 Power Road
London W4 5PY
U. K.
TEL: (0)20 8747 5949

BELGIUM/FRANCE/ LUXEMBOURG/ SWITZERLAND/ HOLLAND/SPAIN/ PORTUGAL

Roland Iberia, S.L.
Paseo García Faria, 33-35
08005 Barcelona SPAIN
TEL: 93 493 91 00

CROATIA

ART-CENTAR
Degenova 3.
HR - 10000 Zagreb
TEL: (1) 466 8493

CZECH REP.

CZECH REPUBLIC
DISTRIBUTOR s.r.o
Vocáárova 247/16
CZ - 180 00 PRAHA 8,
CZECH REP.
TEL: (2) 830 20270

DENMARK

Roland Scandinavia A/S
Nordhavnsvej 7, Postbox 880,
DK-2100 Copenhagen
DENMARK
TEL: 3916 6200

FINLAND

Roland Scandinavia As,
Filial Finland
Elannontie 5
FIN-01510 Vantaa, FINLAND
TEL: (0)9 68 24 020

NORWAY

Roland Scandinavia Avd.
Kontor Norge
Lilleakerveien 2 Postboks 95
Lilleaker N-0216 Oslo
NORWAY
TEL: 2273 0074

SWEDEN

Roland Scandinavia A/S
SWEDISH SALES OFFICE
Danvik Center 28, 2 tr.
S-131 30 Nacka SWEDEN
TEL: (0)8 702 00 20

HUNGARY

Roland East Europe Ltd.
Warehouse Area 'DEPO' Pf.83
H-2046 Torokbalint, HUNGARY
TEL: (23) 511011

POLAND

ROLAND POLSKA SP. Z O.O.
UL. Gibraltarska 4.
PL-03 664 Warszawa
POLAND
TEL: (022) 679 4419

ROMANIA

FBS LINES
Piata Libertatii 1,
535500 Gheorgheni, ROMANIA
TEL: (266) 364 609

RUSSIA

MuTek
Dorozhnaya ul.3,korp.6
117 545 Moscow, RUSSIA
TEL: (095) 981-4967

SLOVAKIA

DAN Acoustic s.r.o.
Povazská 18.
SK - 940 01 Nové Zámky
TEL: (035) 6424 330

UKRAINE

EURHYTHMICS Ltd.
P.O.Box: 37-a.
Nedecey Str. 30
UA - 89600 Mukachevo,
UKRAINE
TEL: (03131) 414-40

OCEANIA

Roland Corporation Australia Pty., Ltd.

38 Campbell Avenue
Dee Why West, NSW 2099
AUSTRALIA

For Australia
Tel: (02) 9982 8266
For New Zealand
Tel: (09) 3098 715

NORTH AMERICA

CANADA

Roland Canada Ltd.
(Head Office)
5480 Parkwood Way, Richmond
B. C., V6V 2M4 CANADA
TEL: (604) 270 6626

Roland Canada Ltd.
(Toronto Office)

170 Admiral Boulevard
Mississauga ON L5T 2N6
CANADA
TEL: (905) 362 9707

U. S. A.

Roland Systems Group U.S.
425 Sequoia Drive Suite 114,
Bellingham, Washington,
98226 USA
TEL: 360-594-4282

As of Oct. 1, 2007 (EDIROL-2)

For EU Countries



- UK** This symbol indicates that in EU countries, this product must be collected separately from household waste, as defined in each region. Products bearing this symbol must not be discarded together with household waste.
- DE** Dieses Symbol bedeutet, dass dieses Produkt in EU-Ländern getrennt vom Hausmüll gesammelt werden muss gemäß den regionalen Bestimmungen. Mit diesem Symbol gekennzeichnete Produkte dürfen nicht zusammen mit dem Hausmüll entsorgt werden.
- FR** Ce symbole indique que dans les pays de l'Union européenne, ce produit doit être collecté séparément des ordures ménagères selon les directives en vigueur dans chacun de ces pays. Les produits portant ce symbole ne doivent pas être mis au rebut avec les ordures ménagères.
- IT** Questo simbolo indica che nei paesi della Comunità europea questo prodotto deve essere smaltito separatamente dai normali rifiuti domestici, secondo la legislazione in vigore in ciascuno paese. I prodotti che riportano questo simbolo non devono essere smaltiti insieme ai rifiuti domestici. Ai sensi dell'art. 13 del D.Lgs. 25 luglio 2005 n. 151.
- ES** Este símbolo indica que en los países de la Unión Europea este producto debe recogerse aparte de los residuos domésticos, tal como está regulado en cada zona. Los productos con este símbolo no se deben depositar con los residuos domésticos.
- PT** Este símbolo indica que nos países da UE, a recolha deste produto deverá ser feita separadamente do lixo doméstico, de acordo com os regulamentos de cada região. Os produtos que apresentem este símbolo não deverão ser eliminados juntamente com o lixo doméstico.
- NL** Dit symbool geeft aan dat in landen van de EU dit product gescheiden van huishoudelijk afval moet worden aangeboden, zoals bepaald per gemeente of regio. Producten die van dit symbool zijn voorzien, mogen niet samen met huishoudelijk afval worden verwijderd.
- DK** Dette symbol angiver, at i EU-lande skal dette produkt opsamles adskilt fra husholdningsaffald, som defineret i hver enkelt region. Produkter med dette symbol må ikke smides ud sammen med husholdningsaffald.
- NO** Dette symbolet indikerer at produktet må behandles som spesialavfall i EU-land, iht. til retningslinjer for den enkelte regionen, og ikke kastes sammen med vanlig husholdningsavfall. Produkter som er merket med dette symbolet, må ikke kastes sammen med vanlig husholdningsavfall.

- SE** Symbolen anger att i EU-länder måste den här produkten kasseras separat från hushållsavfall, i enlighet med varje regions bestämmelser. Produkter med den här symbolen får inte kasseras tillsammans med hushållsavfall.
- FI** Tämä merkintä ilmaisee, että tuote on EU-maissa kerättävä erillään kotitalousjätteistä kunkin alueen voimassa olevien määräysten mukaisesti. Tällä merkinnällä varustettuja tuotteita ei saa hävittää kotitalousjätteiden mukana.
- HU** Ez a szimbólum azt jelenti, hogy az Európai Unióban ezt a terméket a háztartási hulladéktól elkülönítve, az adott régióban érvényes szabályozás szerint kell gyűjteni. Az ezzel a szimbóllal ellátott termékeket nem szabad a háztartási hulladék közé dobni.
- PL** Symbol oznacza, że zgodnie z regulacjami w odpowiednim regionie, w krajach UE produktu nie należy wyrzucać z odpadami domowymi. Produktów opatrzonych tym symbolem nie można utylizować razem z odpadami domowymi.
- CZ** Tento symbol udává, že v zemích EU musí být tento výrobek sbírán odděleně od domácího odpadu, jak je určeno pro každý region. Výrobky nesoucí tento symbol se nesmí vyhazovat spolu s domácím odpadem.
- SK** Tento symbol vyjadruje, že v krajinách EÚ sa musí zber tohto produktu vykonávať oddelene od domového odpadu, podľa nariadení platných v konkrétnej krajine. Produkty s týmto symbolom sa nesmú vyhazovať spolu s domovým odpadom.
- EE** See sümbol näitab, et EL-i maades tuleb see toode olemprügist eraldi koguda, nii nagu on igas piirkonnas määratletud. Selle sümboliga märgitud tooteid ei tohi ära visata koos olmeprügiga.
- LT** Šis simbolis rodo, kad ES šalyse šis produktas turi būti surenkamas atskirai nuo buitinių atliekų, kaip nustatyta kiekviename regione. Šiuo simboliu paženklinėti produktai neturi būti išmetami kartu su buitinių atliekomis.
- LV** Šis simbols norāda, ka ES valstīs šo produktu jāievāc atsevišķi no mājsaimniecības atkritumiem, kā noteikts katrā reģionā. Produkts ar šo simbolu nedrīkst izmest kopā ar mājsaimniecības atkritumiem.
- SI** Ta simbol označuje, da je treba proizvod v državah EU zbirati ločeno od gospodinjjskih odpadkov, tako kot je določeno v vsaki regiji. Proizvoda s tem znakom ni dovoljeno odlagati skupaj z gospodinjjskimi odpadki.
- GR** Το σύμβολο αυτό υποδηλώνει ότι στις χώρες της Ε.Ε. το συγκεκριμένο προϊόν πρέπει να συλλέγεται χωριστά από τα υπόλοιπα οικιακά απορρίμματα, σύμφωνα με όσα προβλέπονται σε κάθε περιοχή. Τα προϊόντα που φέρουν το συγκεκριμένο σύμβολο δεν πρέπει να απορρίπτονται μαζί με τα οικιακά απορρίμματα.

For China

有关产品中所含有害物质的说明

本资料就本公司产品中所含的特定有害物质及其安全性予以说明。
本资料适用于 2007 年 3 月 1 日以后本公司所制造的产品。

环保使用期限



此标志适用于在中国国内销售的电子信息产品，表示环保使用期限的年数。所谓环保使用期限是指在自制造日起的规定期限内，产品中所含的有害物质不致引起环境污染，不会对人身、财产造成严重的不良影响。
环保使用期限仅在遵照产品使用说明书，正确使用产品的条件下才有效。
不当的使用，将会导致有害物质泄漏的危险。

产品中有毒有害物质或元素的名称及含量

部件名称	有毒有害物质或元素					
	铅(Pb)	汞(Hg)	镉(Cd)	六价铬(Cr(VI))	多溴联苯(PBB)	多溴二苯醚(PBDE)
外壳(壳体)	×	○	○	○	○	○
电子部件(印刷电路板等)	×	○	×	○	○	○
附件(电源线、交流适配器等)	×	○	○	○	○	○

○：表示该有毒有害物质在该部件所有均质材料中的含量均在 SJ/T11363-2006 标准规定的限量要求以下。
×：表示该有毒有害物质至少在该部件的某一均质材料中的含量超出 SJ/T11363-2006 标准规定的限量要求。
因根据现有的技术水平，还没有什么物质能够代替它。



For EU Countries

This product complies with the requirements of EMC Directive 2004/108/EC.

For the USA

FEDERAL COMMUNICATIONS COMMISSION RADIO FREQUENCY INTERFERENCE STATEMENT

This equipment has been tested and found to comply with the limits for a Class B digital device, pursuant to Part 15 of the FCC Rules. These limits are designed to provide reasonable protection against harmful interference in a residential installation. This equipment generates, uses, and can radiate radio frequency energy and, if not installed and used in accordance with the instructions, may cause harmful interference to radio communications. However, there is no guarantee that interference will not occur in a particular installation. If this equipment does cause harmful interference to radio or television reception, which can be determined by turning the equipment off and on, the user is encouraged to try to correct the interference by one or more of the following measures:

- Reorient or relocate the receiving antenna.
- Increase the separation between the equipment and receiver.
- Connect the equipment into an outlet on a circuit different from that to which the receiver is connected.
- Consult the dealer or an experienced radio/TV technician for help.

This device complies with Part 15 of the FCC Rules. Operation is subject to the following two conditions:

- (1) this device may not cause harmful interference, and
- (2) this device must accept any interference received, including interference that may cause undesired operation.

Unauthorized changes or modification to this system can void the users authority to operate this equipment.
This equipment requires shielded interface cables in order to meet FCC class B Limit.

For Canada

NOTICE

This Class B digital apparatus meets all requirements of the Canadian Interference-Causing Equipment Regulations.

AVIS

Cet appareil numérique de la classe B respecte toutes les exigences du Règlement sur le matériel brouilleur du Canada.

For the USA

DECLARATION OF CONFORMITY Compliance Information Statement

Model Name : V-8
Type of Equipment : Video Mixer
Responsible Party : Roland Systems Group U.S.
Address : 425 Sequoia Drive Suite 114, Bellingham, Washington, 98226 USA
Telephone : (360) 594-4282



04903812

08-03-2N