

Roland

AV MIXER **VR-3**

Owner's Manual

Before using this unit, carefully read the sections entitled: "USING THE UNIT SAFELY" (p. 4) and "IMPORTANT NOTES" (p. 6). These sections provide important information concerning the proper operation of the unit. Additionally, in order to feel assured that you have gained a good grasp of every feature provided by your new unit, owner's manual should be read in its entirety. The manual should be saved and kept on hand as a convenient reference.



Copyright © 2011 ROLAND CORPORATION

All rights reserved. No part of this publication may be reproduced in any form without the written permission of ROLAND CORPORATION.

* Roland is either registered trademark or trademark of Roland Corporation in the United States and/or other countries.

* All product names mentioned in this document are trademarks or registered trademarks of their respective owners.

For the U.K.

IMPORTANT: THE WIRES IN THIS MAINS LEAD ARE COLOURED IN ACCORDANCE WITH THE FOLLOWING CODE.

BLUE: NEUTRAL
BROWN: LIVE

As the colours of the wires in the mains lead of this apparatus may not correspond with the coloured markings identifying the terminals in your plug, proceed as follows:

The wire which is coloured BLUE must be connected to the terminal which is marked with the letter N or coloured BLACK.

The wire which is coloured BROWN must be connected to the terminal which is marked with the letter L or coloured RED.

Under no circumstances must either of the above wires be connected to the earth terminal of a three pin plug.

Check the included items

The following items are included. Please make sure that all items are present. If anything is missing, please contact your dealer.

VR-3 itself



USB cable (A type - B type)



Owner's manual (this document)

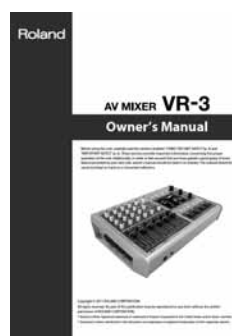

AC adaptor and power cord



The explanations in this manual include illustrations that depict what should typically be shown by the display. Note, however, that your unit may incorporate a newer, enhanced version of the system, so what you actually see in the display may not always match what appears in the manual.

This product is using open source license (GPL/LGPL) software. You have the right to acquire, modify and distribute the source code for this open source license software. You can obtain the open source license source code used in this product by downloading it from the following website.

<http://www.roland.com/support/gpl/>

MMP (Moore Microprocessor Portfolio) refers to a patent portfolio concerned with microprocessor architecture, which was developed by Technology Properties Limited (TPL). Roland has licensed this technology from the TPL Group.

USING THE UNIT SAFELY

INSTRUCTIONS FOR THE PREVENTION OF FIRE, ELECTRIC SHOCK, OR INJURY TO PERSONS

About ⚠ WARNING and ⚠ CAUTION Notices

⚠ WARNING	Used for instructions intended to alert the user to the risk of death or severe injury should the unit be used improperly.
⚠ CAUTION	Used for instructions intended to alert the user to the risk of injury or material damage should the unit be used improperly. * Material damage refers to damage or other adverse effects caused with respect to the home and all its furnishings, as well to domestic animals or pets.

About the Symbols

	The ⚠ symbol alerts the user to important instructions or warnings. The specific meaning of the symbol is determined by the design contained within the triangle. In the case of the symbol at left, it is used for
	The ⚡ symbol alerts the user to items that must never be carried out (are forbidden). The specific thing that must not be done is indicated by the design contained within the circle. In the case of the symbol at left, it means that the unit must never be disassembled.
	The ● symbol alerts the user to things that must be carried out. The specific thing that must be done is indicated by the design contained within the circle. In the case of the symbol at left, it means that the power-cord plug must be unplugged from the outlet.

ALWAYS OBSERVE THE FOLLOWING

⚠ WARNING

- Do not open (or modify in any way) the unit or its AC adaptor.
- Do not attempt to repair the unit, or replace parts within it (except when this manual provides specific instructions directing you to do so). Refer all servicing to your retailer, the nearest Roland Service Center, or an authorized Roland distributor, as listed on the "Information" sheet.
- Never install the unit in any of the following locations.
 - Subject to temperature extremes (e.g., direct sunlight in an enclosed vehicle, near a heating duct, on top of heat-generating equipment); or are
 - Damp (e.g., baths, washrooms, on wet floors); or are
 - Exposed to steam or smoke; or are
 - Subject to salt exposure; or are
 - Humid; or are
 - Exposed to rain; or are
 - Dusty or sandy; or are
 - Subject to high levels of vibration and shakiness.
- Make sure you always have the unit placed so it is level and sure to remain stable. Never place it on stands that could wobble, or on inclined surfaces.
- Be sure to use only the AC adaptor supplied with the unit. Also, make sure the line voltage at the installation matches the input voltage specified on the AC adaptor's body. Other AC adaptors may use a different polarity, or be designed for a different voltage, so their use could result in damage, malfunction, or electric shock.
- Use only the attached power-supply cord. Also, the supplied power cord must not be used with any other device

⚠ WARNING

- Do not excessively twist or bend the power cord, nor place heavy objects on it. Doing so can damage the cord, producing severed elements and short circuits. Damaged cords are fire and shock hazards!
- This unit, either alone or in combination with an amplifier and headphones or speakers, may be capable of producing sound levels that could cause permanent hearing loss. Do not operate for a long period of time at a high volume level, or at a level that is uncomfortable. If you experience any hearing loss or ringing in the ears, you should immediately stop using the unit, and consult an audiologist.
- Do not place containers containing liquid on this product. Never allow foreign objects (e.g., flammable objects, coins, wires) or liquids (e.g., water or juice) to enter into this product. Doing so may cause short circuits, faulty operation, or other malfunctions.
- Immediately turn the power off, remove the AC adaptor from the outlet, and request servicing by your retailer, the nearest Roland Service Center, or an authorized Roland distributor, as listed on the "Information" sheet when:
 - The AC adaptor, the power-supply cord, or the plug has been damaged; or
 - If smoke or unusual odor occurs
 - Objects have fallen into, or liquid has been spilled onto the unit; or
 - The unit has been exposed to rain (or otherwise has become wet); or
 - The unit does not appear to operate normally or exhibits a marked change in performance.
- In households with small children, an adult should provide supervision until the child is capable of following all the rules essential for the safe operation of the unit.

⚠ WARNING

- Protect the unit from strong impact. (Do not drop it!) 

- Do not force the unit's power-supply cord to share an outlet with an unreasonable number of other devices. Be especially careful when using extension cords—the total power used by all devices you have connected to the extension cord's outlet must never exceed the power rating (watts/amperes) for the extension cord. Excessive loads can cause the insulation on the cord to heat up and eventually melt through. 

- Before using the unit in a foreign country, consult with your retailer, the nearest Roland Service Center, or an authorized Roland distributor, as listed on the "Information" sheet. 

⚠ CAUTION

- The unit and the AC adaptor should be located so their location or position does not interfere with their proper ventilation. 

- Always grasp only the plug on the AC adaptor cord when plugging into, or unplugging from, an outlet or this unit. 

- At regular intervals, you should unplug the AC adaptor and clean it by using a dry cloth to wipe all dust and other accumulations away from its prongs. Also, disconnect the power plug from the power outlet whenever the unit is to remain unused for an extended period of time. Any accumulation of dust between the power plug and the power outlet can result in poor insulation and lead to fire. 

- Try to prevent cords and cables from becoming entangled. Also, all cords and cables should be placed so they are out of the reach of children. 

- Never climb on top of, nor place heavy objects on the unit. 

- Never handle the AC adaptor or its plugs with wet hands when plugging into, or unplugging from, an outlet or this unit. 

- Before moving the unit, disconnect the AC adaptor and all cords coming from external devices. 

- Before cleaning the unit, turn off the power and unplug the AC adaptor from the outlet (p.8). 

- Whenever you suspect the possibility of lightning in your area, disconnect the AC adaptor from the outlet. 

- If you remove the screw from the ground terminal, be sure to replace it; don't leave it lying around where it could accidentally be swallowed by small children. When refastening the screw, make that it is firmly fastened, so it won't come loose. 

- Always turn the phantom power off when connecting any device other than condenser microphones that require phantom power. You risk causing damage if you mistakenly supply phantom power to dynamic microphones, audio playback devices, or other devices that don't require such power. Be sure to check the specifications of any microphone you intend to use by referring to the manual that came with it.
(This unit's phantom power: +48 V DC, 5 mA Max) 

IMPORTANT NOTES

Power Supply

- Do not connect this unit to same electrical outlet that is being used by an electrical appliance that is controlled by an inverter (such as a refrigerator, washing machine, microwave oven, or air conditioner), or that contains a motor. Depending on the way in which the electrical appliance is used, power supply noise may cause this unit to malfunction or may produce audible noise. If it is not practical to use a separate electrical outlet, connect a power supply noise filter between this unit and the electrical outlet.
- The AC adaptor will begin to generate heat after long hours of consecutive use. This is normal, and is not a cause for concern.
- Before connecting this unit to other devices, turn off the power to all units. This will help prevent malfunctions and/or damage to monitors or other devices.
- With the factory settings, the VR-3's power will automatically be switched off if all these 3 statuses continue 240 minutes.
 - No operation is carried out (including remote control operation).
 - No video signal is input.
 - No audio signal higher than -64 dBu is input.
- * You can disable the AUTO OFF feature by going to the [SYSTEM] menu and setting [AUTO OFF] to [OFF]. Refer to "Menu Operations" (p. 44) and "SYSTEM Menu" (p. 47).
- * The settings you were editing will be lost when the power is turned off. If you want to keep your settings, you must save your settings before turning the power off.

Placement

- Using the unit near power amplifiers (or other equipment containing large power transformers) may induce hum. To alleviate the problem, change the orientation of this unit; or move it farther away from the source of interference.
- This device may interfere with radio and television reception. Do not use this device in the vicinity of such receivers.
- Noise may be produced if wireless communications devices, such as cell phones, are operated in the vicinity of this unit. Such noise could occur when receiving or initiating a call, or while conversing. Should you experience such problems, you should relocate such wireless devices so they are at a greater distance from this unit, or switch them off.
- Do not expose the unit to direct sunlight, place it near devices that radiate heat, leave it inside an enclosed vehicle, or otherwise subject it to temperature extremes. Excessive heat can deform or discolor the unit.
- When moved from one location to another where the temperature and/or humidity is very different, water droplets (condensation) may form inside the unit. Damage or malfunction may result if you attempt to use the unit in this condition. Therefore, before using the unit, you must allow it to stand for several hours, until the condensation has completely evaporated.
- Depending on the material and temperature of the surface on which you place the unit, its rubber feet may discolor or mar the surface. You can place a piece of felt or cloth under the rubber feet to prevent this from happening. If you do so, please make sure that the unit will not slip or move accidentally.
- Do not put anything that contains water on this unit. Also, avoid the use of insecticides, perfumes, alcohol, nail polish, spray cans, etc., near the unit. Swiftly wipe away any liquid that spills on the unit using a dry, soft cloth.

Maintenance

- For everyday cleaning wipe the unit with a soft, dry cloth or one that has been slightly dampened with water. To remove stubborn dirt, use a cloth impregnated with a mild, non-abrasive detergent. Afterwards, be sure to wipe the unit thoroughly with a soft, dry cloth.
- Never use benzine, thinners, alcohol or solvents of any kind, to avoid the possibility of discoloration and/or deformation.

Additional Precautions

- This unit allows you to switch images at high speed. For some people, viewing such images can cause headache, nausea, or other discomfort. Do not use this unit to create video that might cause these types of health problems. Roland Corporation will accept no responsibility for any such health problems that may occur in yourself or in viewers.
- Use a reasonable amount of care when using the unit's buttons, sliders, or other controls; and when using its jacks and connectors. Rough handling can lead to malfunctions.
- Never strike or apply strong pressure to the display.
- When connecting / disconnecting all cables, grasp the connector itself—never pull on the cable. This way you will avoid causing shorts, or damage to the cable's internal elements.
- To avoid disturbing your neighbors, try to keep the unit's volume at reasonable levels. You may prefer to use headphones, so you do not need to be concerned about those around you (especially when it is late at night).
- When you need to transport the unit, package it in the box (including padding) that it came in, if possible. Otherwise, you will need to use equivalent packaging materials.
- Some connection cables contain resistors. Do not use cables that incorporate resistors for connecting to this unit. The use of such cables can cause the sound level to be extremely low, or impossible to hear. For information on cable specifications, contact the manufacturer of the cable.

Others

- Security Slot
<http://www.kensington.com/>

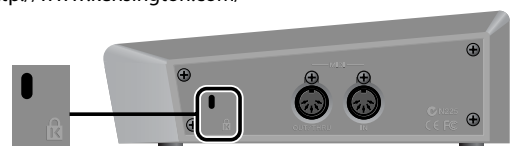

Contents

Power Supply	8
Connecting the AC Adapter	8
Turning the Power On	9
Turning the Power Off	9
Names of Things and What They Do	10
Top Panel	10
Audio Mixer Section	11
Video Select Section	12
Rear Panel	14
Left Side Panel	15
Right Side Panel	15
Front Panel	15
Signal Flow	16
Connecting External Equipment	17
Connecting Video Sources	18
Connecting Audio Sources	18
Connecting a Computer	20
Connecting Output Equipment	21
Connecting a Projector or Recording Unit	21
Connecting an Amplifier, Speakers, and Recorders	21
Connecting a Preview Monitor	21
Basic Operation	22
Switching the Video	22
Automatically Switching the Video	24
Freezing the Final Output	24
Applying a Fade to Final Video Output	24
Adjusting the Audio Balance	25
Adjusting the Final Audio Output	28
Compositing the Picture	29
Compositing Using Picture-in-Picture	29
Adjusting the Position and Size of the Inset Screen	31
Compositing Using Split	32
Compositing Using Luminance Key/Chroma Key	34
Compositing Using Luminance Key	34
Compositing Using Chroma Key	36
Performing Output from the USB Port	38
Connecting a Computer	38
Performing Output to a Computer	40
Using Other Features	41
Changing the Size and Position of Overlay Display	41
Applying Effects to Audio	41
Saving/Recalling Settings	43
Returning to the Factory-default State	43
Switching Between NTSC and PAL	43
Menu Operations and Menu List	44
Menu Operations	44
Menu List	45
Appendices	48
Main Specifications	48
About Remote Control	48
Troubleshooting	49
Dimensions	50

Power Supply

Connecting the AC Adapter

Connect the AC adapter as shown in the figure below. Position the AC adapter so that the surface where the indicator is located (see figure) is facing up. Connecting the AC adapter to a power outlet makes the indicator light up.

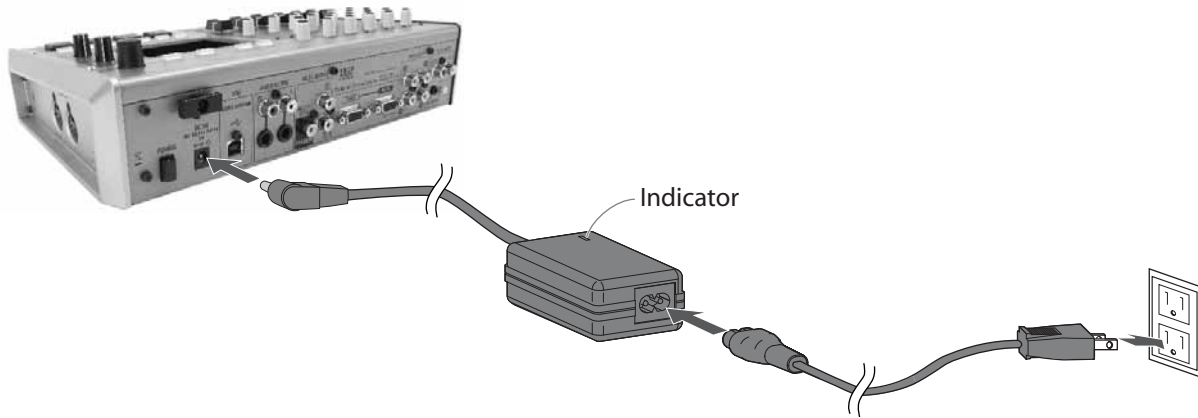

Cord Hook

To prevent the inadvertent disruption of power to your unit (should the plug be pulled out accidentally), and to avoid applying undue stress to the AC adaptor jack, anchor the power cord using the cord hook, as shown in the illustration.

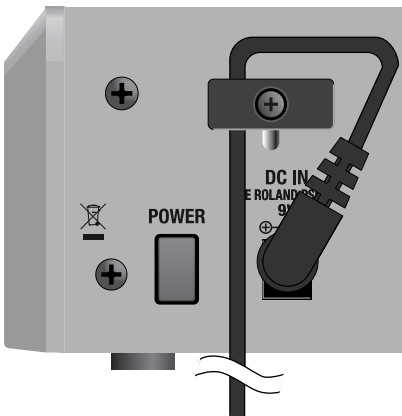

Caution Regarding the Power Supply

Depending on the circumstances of a particular setup, you may experience a discomforting sensation, or perceive that the surface feels gritty to the touch when you touch this device, microphones connected to it, or the metal portions of other objects. This is due to an infinitesimal electrical charge, which is absolutely harmless. However, if you are concerned about this, connect the ground terminal (see figure) with an external ground. When the unit is grounded, a slight hum may occur, depending on the particulars of your installation. If you are unsure of the connection method, contact the nearest Roland Service Center, or an authorized Roland distributor, as listed on the "Information" sheet.

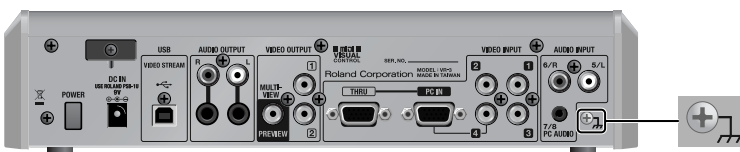

Unsuitable places for connection

- Water pipes (may result in shock or electrocution)
- Gas pipes (may result in fire or explosion)
- Telephone-line ground or lightning rod (may be dangerous in the event of lightning)

Turning the Power On

- * Once the connections have been completed (p. 8), turn on power to your various devices in the order specified. By turning on devices in the wrong order, you risk causing malfunction and/or damage to speakers and other devices.
- * This unit is equipped with a protection circuit. A brief interval (a few seconds) after power up is required before the unit will operate normally.
- * Always make sure to have the volume level turned down before switching on power. Even with the volume all the way down, you may still hear some sound when the power is switched on, but this is normal, and does not indicate a malfunction.

Make sure the power cable is securely inserted, then press the [POWER] button located on the rear panel. The buttons and indicators on the top panel flash, and the VR-3 starts up.

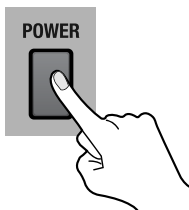

Turning the Power Off

Press the [POWER] button on the rear panel. The buttons and indicators on the top panel go dark, and the power to the VR-3 is switched off.

About AUTO OFF

When all of the conditions described below continue for 240 minutes or longer, the AUTO OFF feature automatically turns off power of the VR-3.

- No operation is carried out (including remote control operation).
- No video signal is input.
- No audio signal higher than -64 dBu is input.

MEMO

You can disable the AUTO OFF feature by going to the [SYSTEM] menu and setting [AUTO OFF] to [OFF]. Refer to "Menu Operations" (p. 44) and "SYSTEM Menu" (p. 47).

NOTE

The settings you were editing will be lost when the power is turned off. If you want to keep your settings, you must save your settings before turning the power off.

Names of Things and What They Do

Top Panel

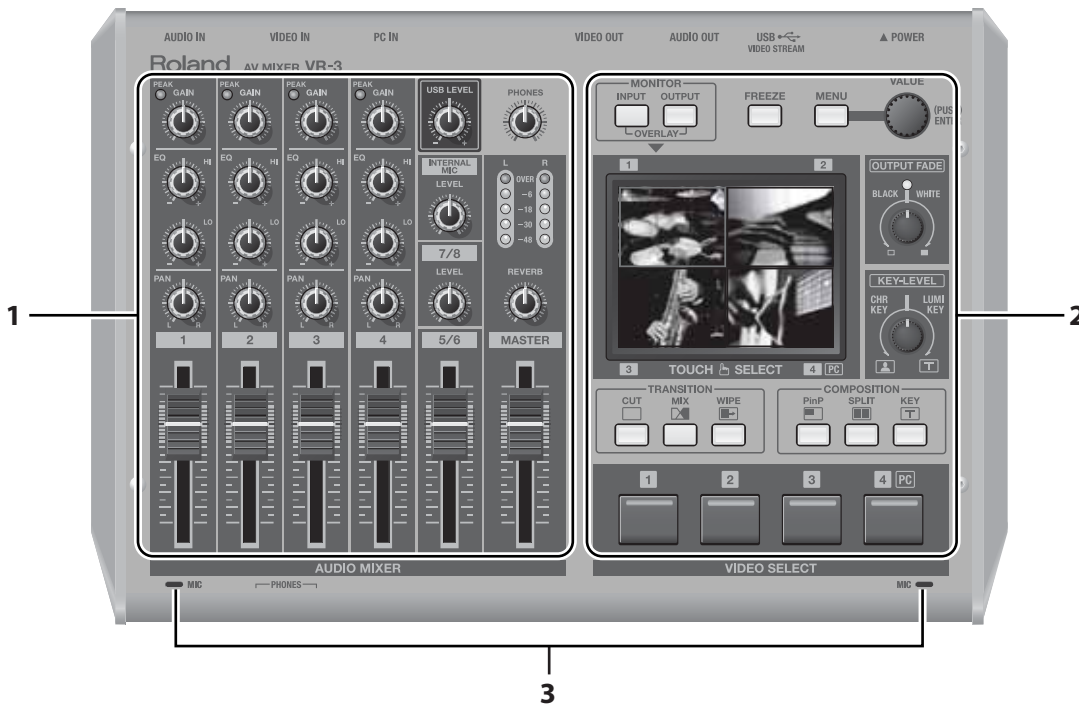

1. Audio Mixer Section (p. 11)

This section is for audio mixing. Use the dials and faders to adjust the input sensitivity, output levels, and other values for each channel.

2. Video Select Section (p. 12)

This section is for switching and compositing video. Use the buttons and dials to select transition effects and compositing modes.

3. Internal Stereo Microphones

Internal microphones for picking up ambient audio are located on the left and right sides of the top panel. To adjust the level, use [LEVEL] dial of [INTERNAL MIC].

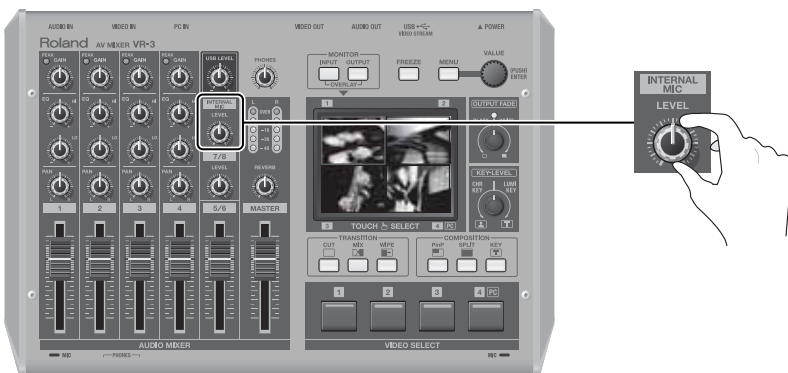

NOTE

When adjusting buttons or faders, some handling noise may be heard in the internal microphones.

Audio Mixer Section

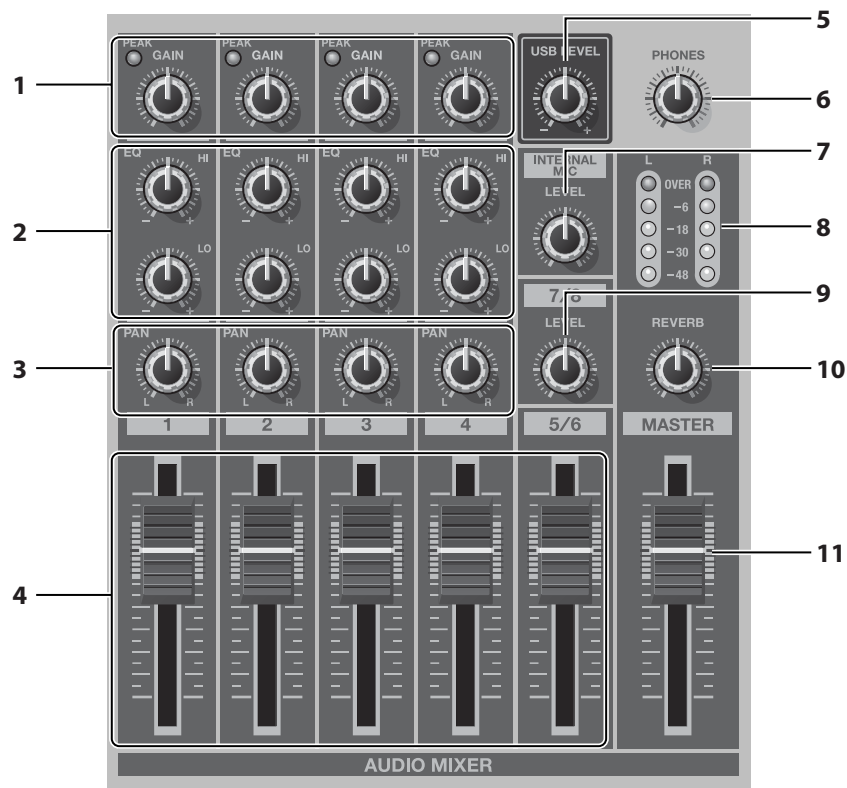
**1. GAIN Dials and PEAK Indicators**

Use the [GAIN] dials to adjust the input sensitivity for channels 1 through 4. When the volume level exceeds the maximum input level, the corresponding [PEAK] indicator lights up. Excessive input volume may result in clipping or distortion. Set the [GAIN] dials for adequate audio level without clipping.

2. EQ Dials (p. 26)

Use the [Hi] dials to emphasize or attenuate the high band. Use the [Lo] dials to emphasize or attenuate the low band.

3. PAN Dials (p. 26)

These adjust the stereo position of the respective channels.

4. Channel Faders (p. 25)

These faders adjust the amount of signal being sent from each channel and the amount of signal each channel sends to the final output (MASTER).

5. USB LEVEL Dial (p. 40)

This adjusts the audio level for USB output.

6. PHONES Dial

This adjusts the level for headphones output.

7. INTERNAL MIC LEVEL Dial (p. 26)

This adjusts the level for the internal microphones.

8. Level Meter (p. 28)

This displays the audio output level. If [OVER] lights up, distortion might occur. Turn down the [MASTER] level if the [OVER] indicator lights up.

9. 7/8 LEVEL Dial

This adjusts the level of audio input coming from a computer connected to the [7/8] connector on the rear panel.

10. REVERB Dial (p. 28)

This adjusts the amount of reverb applied to output.

11. MASTER Fader (p. 28)

This adjusts the level for final output.

Video Select Section

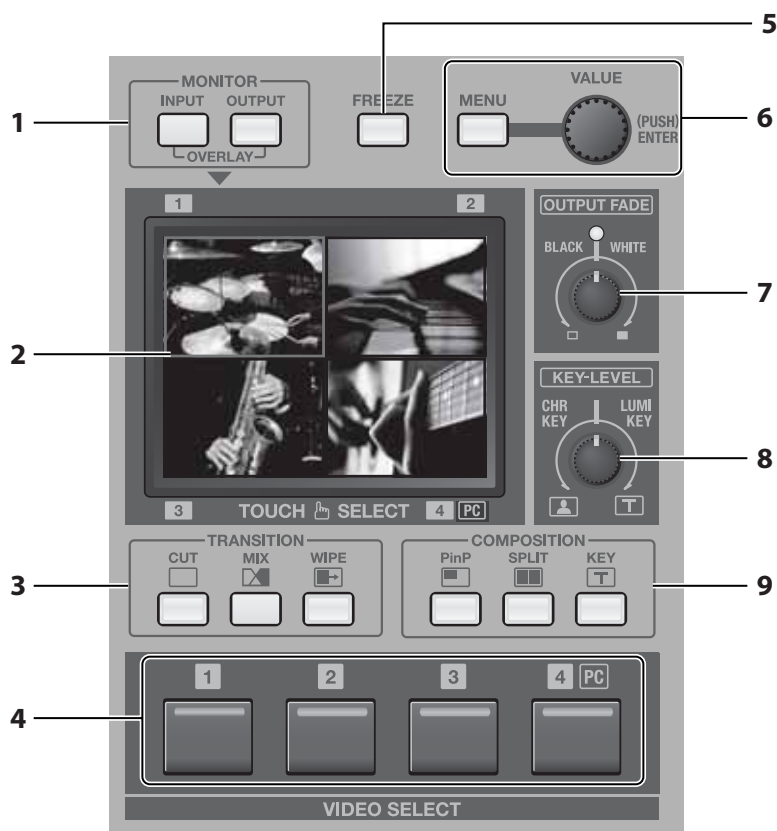

1. MONITOR Buttons

These switch the view mode for the monitor. Choose a mode from the followings.

- [INPUT]
This displays the inputs from the respective source devices.
- [OUTPUT]
This displays the result of video mixing on the VR-3 (the final output).
- OVERLAY
When the [INPUT] button and [OUTPUT] button are pressed simultaneously, the output picture is overlaid on a four-way split screen of the input.

2. Monitor

When the view mode is set to [INPUT], you can switch the video by touching the screen. When the mode is set to [OUTPUT], you can adjust the position and size of the Picture-in-Picture (PinP) inset screen. Menus are also displayed here.

* During two-screen compositing, the background picture can be switched by touching the screen.

3. TRANSITION Buttons (p. 22)

You can select a transition effect for the video using these buttons. When switching from one video source to another, this effect will be applied during the transition.

4. VIDEO SELECT Buttons (p. 23)

You can use these buttons to switch the video instead of the touch panel.

* During two-screen compositing, use buttons [1] through [4] to switch the inset screen or foreground picture.

5. FREEZE Button (p. 24)

Use this button to freeze the final output image.

6. MENU Button and VALUE Dial (p. 44)

Use the [MENU] button to call up various menus on the VR-3. The menus are displayed on the monitor.

The [VALUE] dial is for changing settings. Press the [VALUE] dial to apply a new setting (ENTER).

* You can change a setting value up or down by ten units at a time by holding the [VALUE] dial down while you turn it.

7. OUTPUT FADE Dial (p. 24)

Use this when you want to apply a fade-in or fade-out to final output from the VR-3. Turning the dial counterclockwise applies a black fade, and turning it clockwise applies a white fade. Applying a fade makes the indicator above the dial flash.

8. KEY LEVEL Dial (p. 35, p. 37)

This adjusts the degree of the extraction (removal) in key compositing. The extraction color for key compositing differs according to the direction in which you turn the dial. At the center position, no extraction at all occurs. (The background video is not visible.) Turning the dial all the way clockwise or counterclockwise enables complete extraction, and the foreground picture is not visible. Turn the dial slowly to find the optimal degree of extraction.

- [LUMI KEY] Turning the dial clockwise enables luminance-key compositing. Black or white backgrounds are extracted.
- [CHR KEY] Turning the dial counterclockwise enables chroma-key compositing. Blue or green backgrounds are extracted.

* In the factory-default state, black is the extraction color for luminance-key compositing, and blue is the extraction color for chroma-key composition. You can use the menus to change the extraction color. Refer to "Menu Operations" (p. 44) and "VIDEO Menu" (p. 45).

Examples of Key Compositing

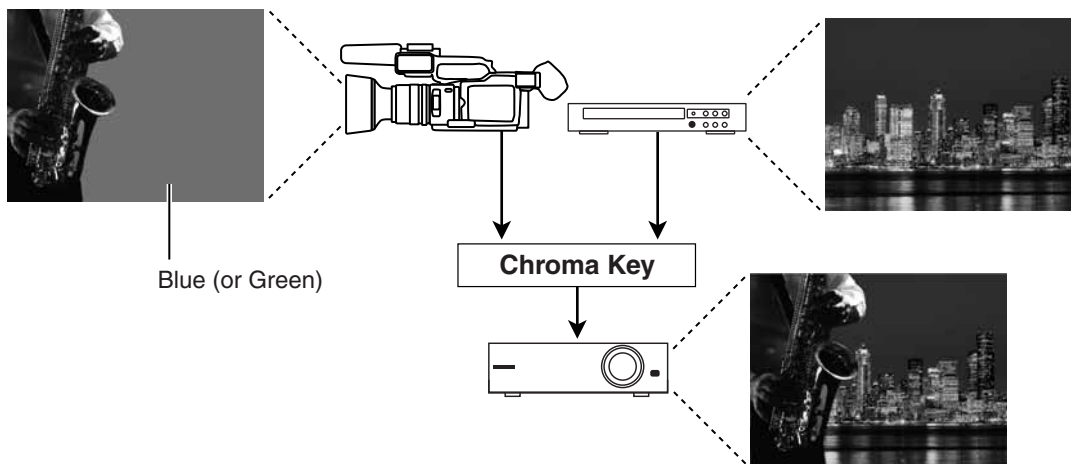
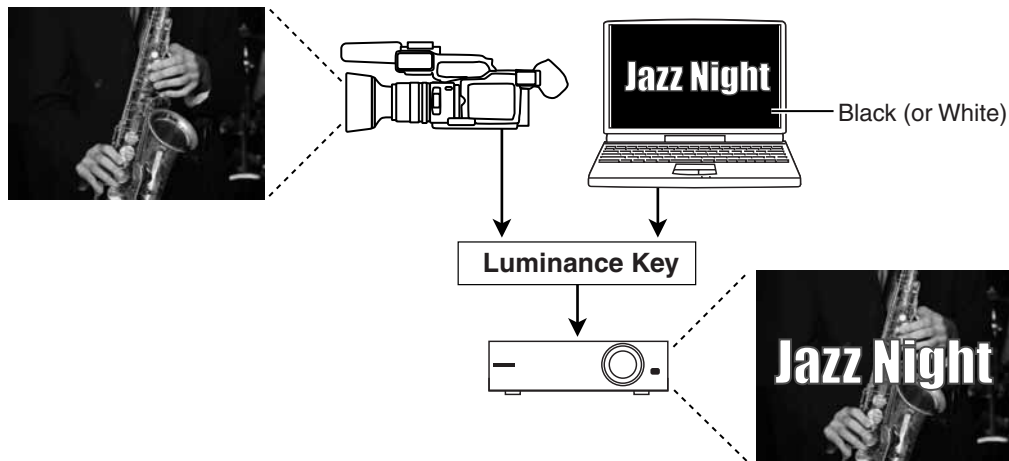

9. COMPOSITION Buttons (p. 29, p. 33, p. 34)

You can select a composition mode from below using buttons here.

- [PinP] This performs Picture-in-Picture compositing.
- [SPLIT] This performs compositing with the screen split vertically or horizontally.
- [KEY] This performs compositing using chroma key or luminance key.

Rear Panel

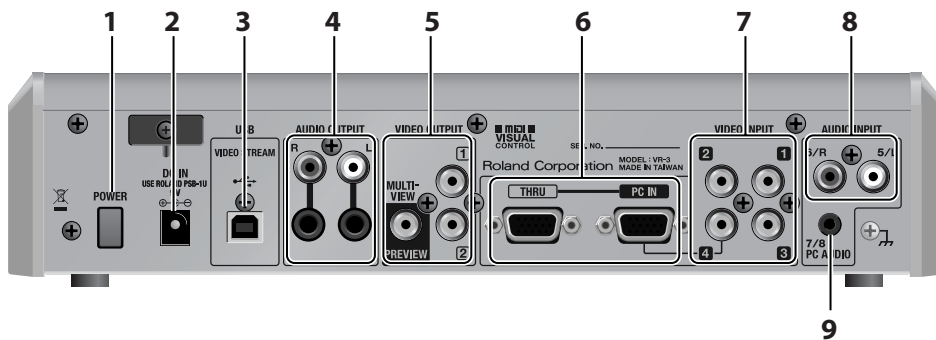

1. POWER Button

This switches the power to the VR-3 on and off.

2. DC IN Connector

This is for connecting the included AC adapter.

* Use the cord hook to secure the AC adapter cord in place (p. 8).

3. USB Port

You can use this to output the results of video and audio mixing on the VR-3 to a computer.

4. AUDIO OUTPUT Connectors

These output the results of audio mixing. Connect output equipment (an amplifier or speakers) and recording equipment (such as a video recorder).

5. VIDEO OUTPUT Connectors

These output the results of video mixing. Connect output equipment (such as a projector) and recording equipment (such as a video recorder).

The PREVIEW connector is for connecting a preview monitor.

6. PC IN and THRU Connectors

You can connect RGB output from a computer to the PC IN connector and input logos, text, or still images. Input made via this connector is assigned to channel 4. When composite input and RGB input are made to channel 4 at the same time, the RGB input takes priority.

The THRU connector is for connecting a computer monitor.

NOTE

Small text from a computer may not be shown clearly on the final output. If you input text, the font size should be big enough.

7. VIDEO INPUT Connectors

Use these to connect video cameras or other video sources. When composite input and RGB input are made to channel 4 at the same time, the RGB input takes priority.

* You can use the menus to lock the channel-4 input to composite or RGB. Go to the [SYSTEM] menu and select [PC IN], then use [CH4 INPUT SOURCE] to select [PC IN] or [VIDEO]. Refer to "Menu Operations" (p. 44) and "SYSTEM Menu" (p. 47).

8. AUDIO INPUT Connectors

These are for connecting the audio output of video players or other source equipment. Input made via the RCA connectors is assigned to channels 5/6.

9. PC AUDIO Connector

This is for connecting audio output from a computer. Input from the computer is assigned to channels 7/8.

Left Side Panel

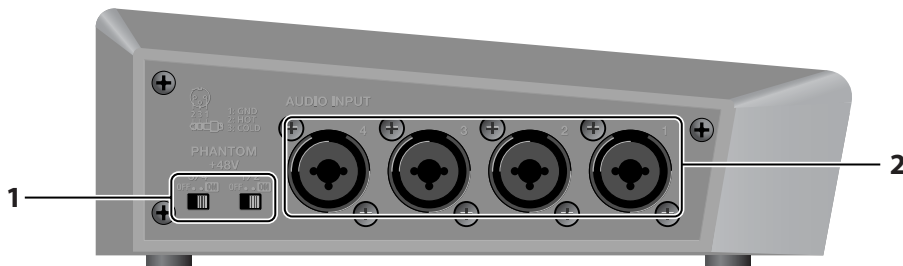

1. PHANTOM +48V Switch (p. 19)

This switches the phantom power of the AUDIO INPUT (XLR/TRS) connectors on and off. The unit has a switch for channels 1/2 and a switch for channels 3/4.

2. AUDIO INPUT (XLR/TRS) Connectors

These are for connecting microphones or an external audio mixer, or other audio sources. Input made via these connectors is assigned to channels 1 through 4.

Right Side Panel

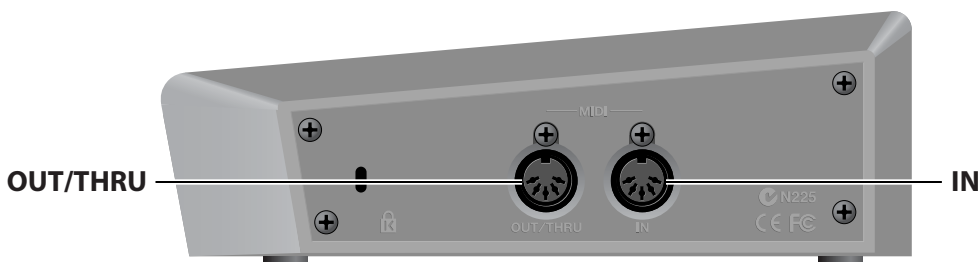

MIDI IN and MIDI OUT/THRU connectors are equipped here. You can connect external MIDI devices to remote control the VR-3. Refer to "About Remote Control" (p. 48).

Front Panel



Two headphones (PHONES) connectors are located here. You can use these to connect standard-type (1/4-inch) headphones and mini-stereo headphones.

NOTE

The volume levels for the two PHONES connectors cannot be adjusted independently. Operating the [PHONES] dial changes the volume for both simultaneously.

Signal Flow

Signal flow inside the VR-3 is as shown in the figure below.

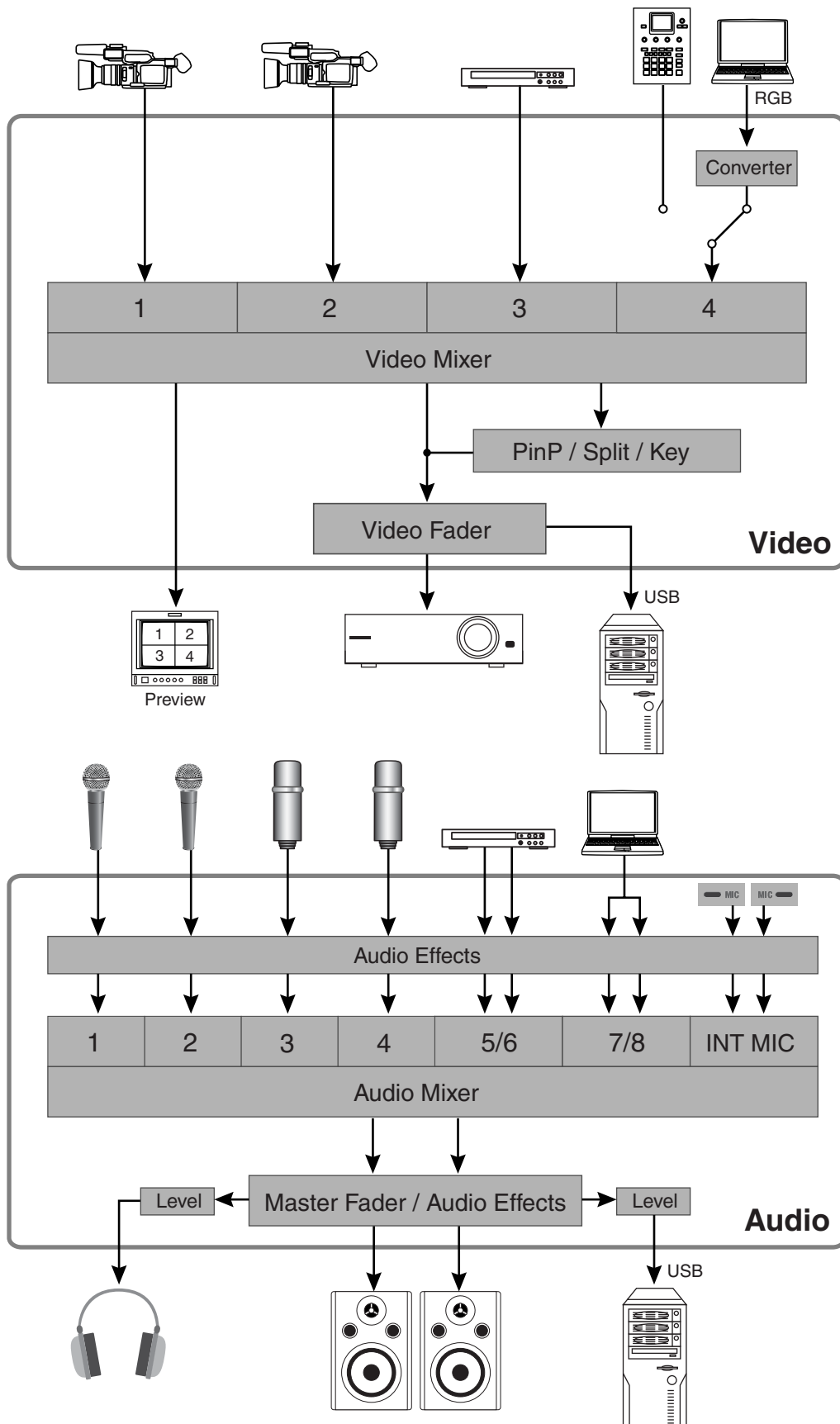

Connecting External Equipment

You can connect external equipment as shown below. For information on specific connections, refer to the following pages.

* To prevent malfunction and/or damage to speakers or other devices, always turn down the volume, and turn off the power on all devices before making any connections.

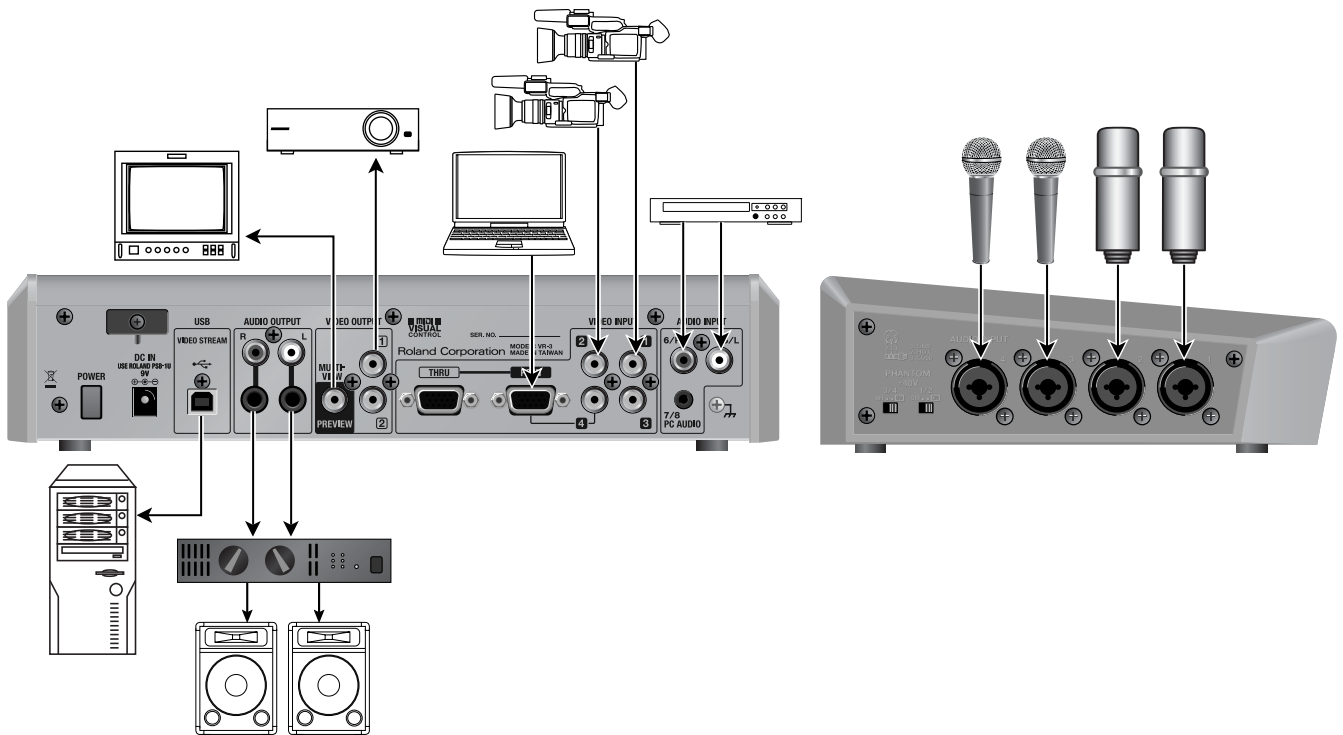

This unit is equipped with balanced (XLR/TRS) type jacks. Wiring diagrams for these jacks are shown below. Make connections after first checking the wiring diagrams of other equipment you intend to connect.

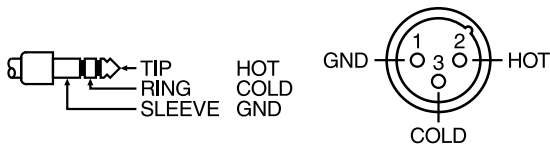

Howling could be produced depending on the location of microphones relative to speakers. This can be remedied by:

1. Changing the orientation of the microphone(s).
2. Relocating microphone(s) at a greater distance from speakers.
3. Lowering volume levels.

Connecting Video Sources

Connect video cameras, DVD players, and other sources to the VIDEO INPUT connectors.

* Channel 4 has a composite connector and a RGB connector, and when input is made through both at the same time, the RGB input takes priority.

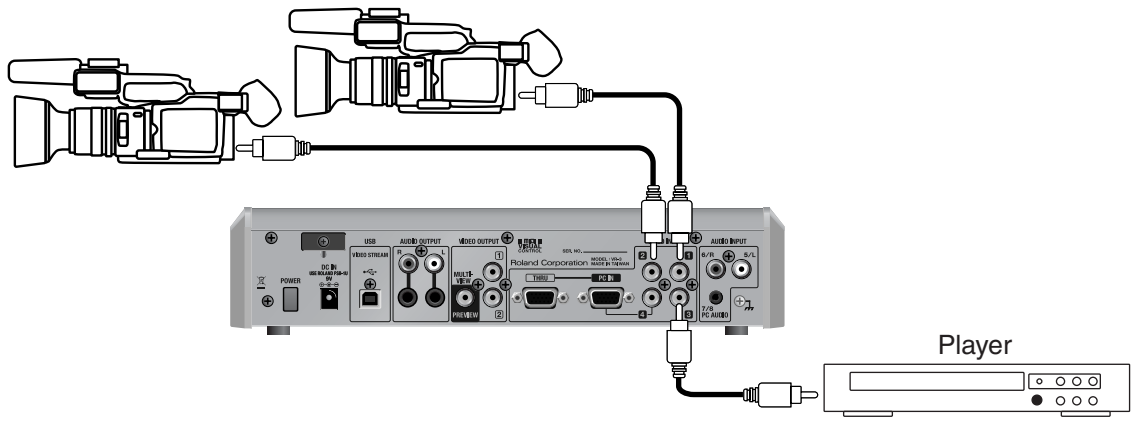

Connecting Audio Sources

* When connection cables with resistors are used, the volume level of equipment connected to the audio inputs may be low. If this happens, use connection cables that do not contain resistors.

Connecting Audio Players

Connect the audio output from video players, CD players, and other devices to the AUDIO INPUT connectors.

* When making the connection, be careful to connect the left and right lines correctly.

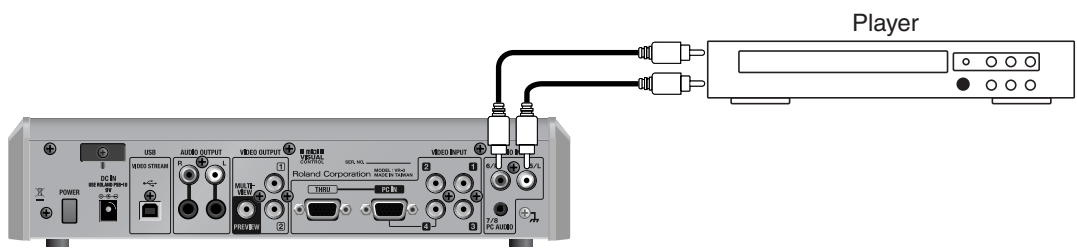

Connecting Microphones

Connect microphones to the AUDIO INPUT connectors on the left side panel. When you are connecting a condenser microphone or other device that requires a supply of +48 V phantom power, set the [PHANTOM +48V] switch to ON.

* The unit has one [PHANTOM +48V] switch for channels 1/2 and one for channels 3/4. Set the switch to correspond to the connector where the device is connected.

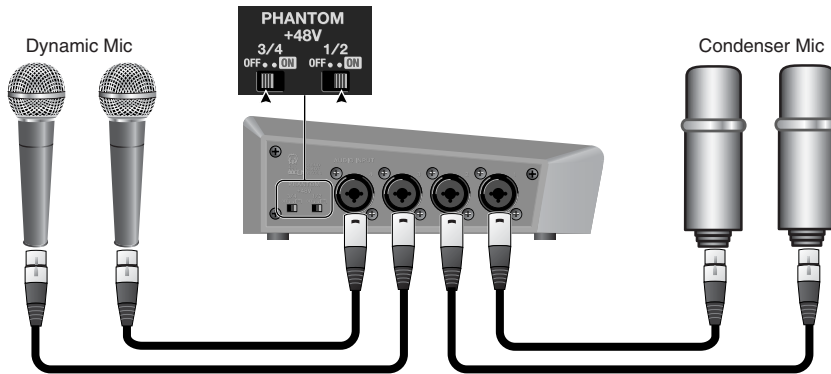

NOTE

When you are connecting a dynamic microphone or other device that does not require power supply, be sure to set the [PHANTOM +48V] switch to OFF. Making the connection while the switch is left set to ON may cause malfunction. (Phantom power on the VR-3: +48 VDC/maximum 5 mA per channel)

NOTE

When one or both of the [PHANTOM +48V] switches is set to ON, current consumption increases by approximately 200 mA per switch.

Connecting an External Audio Mixer

When the number of audio channels is large, such as when you are recording a band performance, make the connections to the AUDIO INPUT connectors via an external audio mixer.

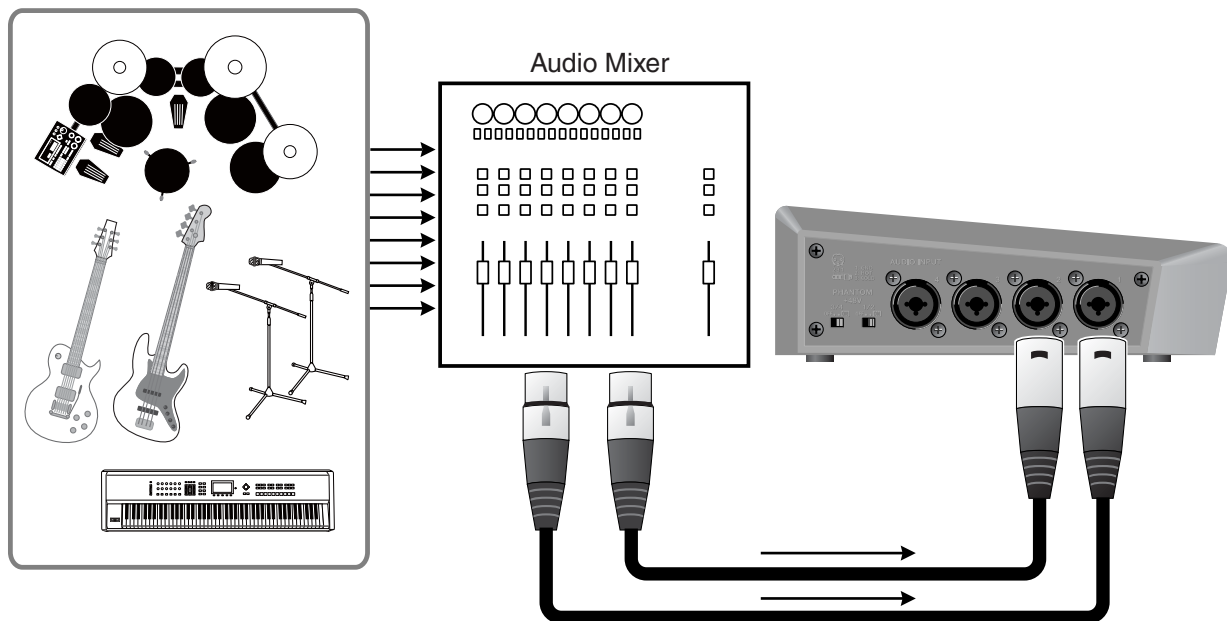

Connecting a Computer

Connect the external output of the computer to the PC IN connector. A built-in scan converter converts the incoming RGB signal to a video signal. When you are connecting a monitor for a desktop computer, use the THRU connector.

- * The resolutions supported by the internal scan converter are as shown in the table. Input signals at a supported resolution.
- * When connecting audio output from the computer to the PC AUDIO connector, use a mini-stereo cable. To adjust the volume level, use the [7/8 LEVEL] dial.

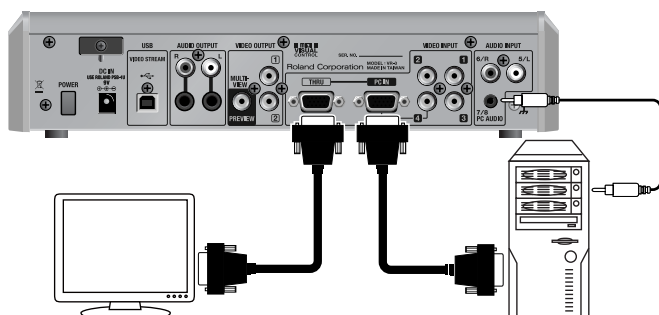

Supported Resolutions

SVGA	800 x 600 / 120Hz	Mac16inch	832 x 624 / 75Hz
XGA	1024 x 768 / 80Hz	XGA+	1152 x 864 / 75Hz
Mac21inch	1152 x 870 / 75Hz	HD720p	1280 x 720 / 60Hz
WideXGA	1280 x 768 / 75Hz	WXGA	1280 x 800 / 75Hz
SXGA	1280 x 1024 / 75Hz	FWXGA	1366 x 768 / 75Hz

* The refresh rate is the maximum value of each resolution.

TIP

The PC IN connector on the VR-3 is D-Sub 15-pin. If necessary, you can use a DVI-VGA adaptor to connect your DVI output to the D-Sub 15-pin connector. A DVI-VGA adapter is not included. Please purchase separately.

MEMO

When displaying video from your PC that has intense motion, the output video may display some flicker or visual corruption. This is called tearing, and does not indicate malfunction.

MEMO

At the [SYSTEM] menu, under [PC IN], when [INPUT RESOLUTION] is set to [AUTO], the resolution of the input signal is detected automatically. If the resolution is not detected correctly, set the resolution manually.

Connecting Output Equipment

Connecting a Projector or Recording Unit

Connect projectors and recorders at the VIDEO OUTPUT connectors.

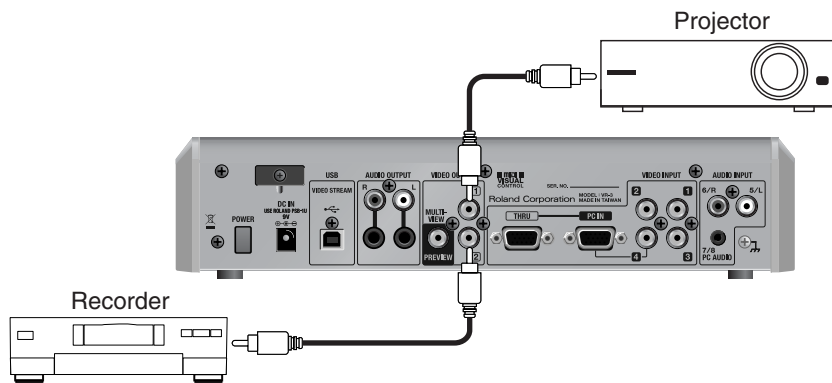

Connecting an Amplifier, Speakers, and Recorders

Connect an amplifier, speakers or a recorder to the AUDIO OUTPUT connectors. The VR-3 has standard TRS and RCA type AUDIO OUTPUT connectors, and the same audio is output from both types.

* Nominal output level of the VR-3 is -10 dBu. Connect equipment that supports input at -10 dBu.

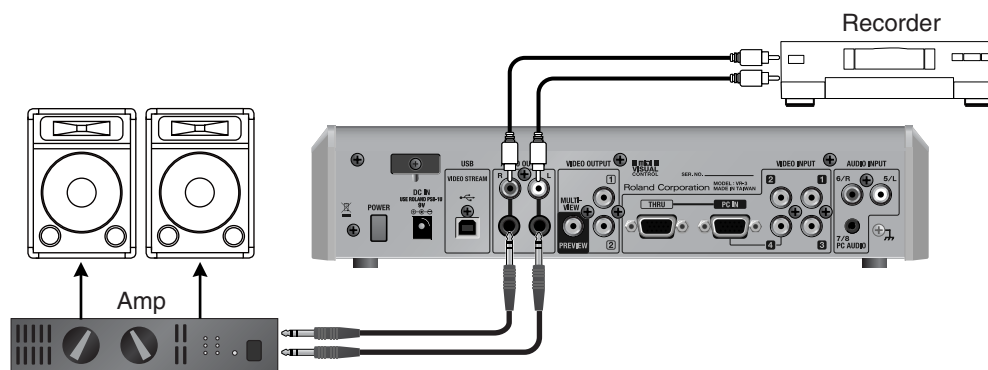

Connecting a Preview Monitor

A preview monitor connected to the PREVIEW connector displays the same preview screen that appears on the built-in monitor. The preview video selected using the [MONITOR] buttons is output.

* The monitor connected to the PREVIEW connector does not show the menu screens.

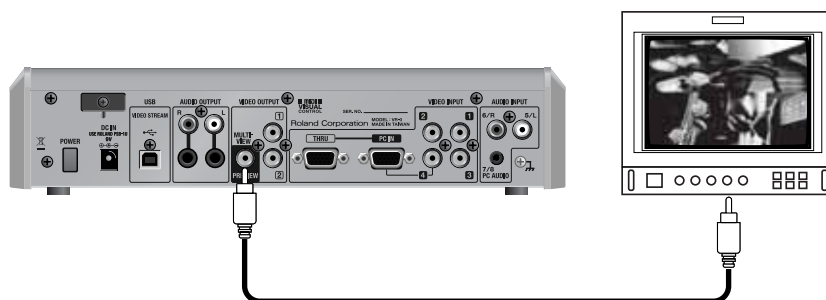

MEMO

When you want to display a four-way split screen as shown in the figure above, use the [MONITOR] buttons to select [INPUT].

Basic Operation

This section describes how to switch (transition) video inputs and mix audio inputs from external sources.

Switching the Video

NOTE

If a fade is applied to the final output, the video is not output to a projector or other output devices. Adjust the [OUTPUT FADE] dial to its center position. For information about fades in final output, refer to "Applying a Fade to Final Video Output" (p. 24).

Using the Touch Panel to Switch the Video

1. Display the input from the sources.

At [MONITOR], press the [INPUT] button. The input from the respective source is displayed at [1] through [4]. When the VR-3 starts up, [1] is selected, and a red border is displayed around the [1] section.

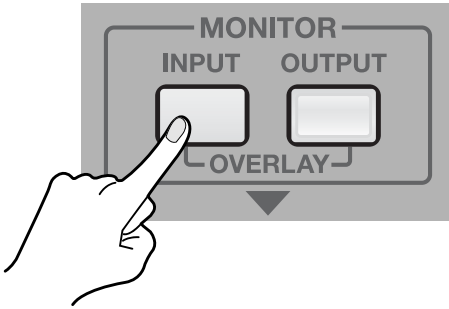

2. Select a transition effect.

Use the [TRANSITION] buttons to select a transition effect. When you are selecting [CUT], the switch is instantaneous, and no transition effect is applied. If you want to apply a transition effect, select [MIX] or [WIPE].

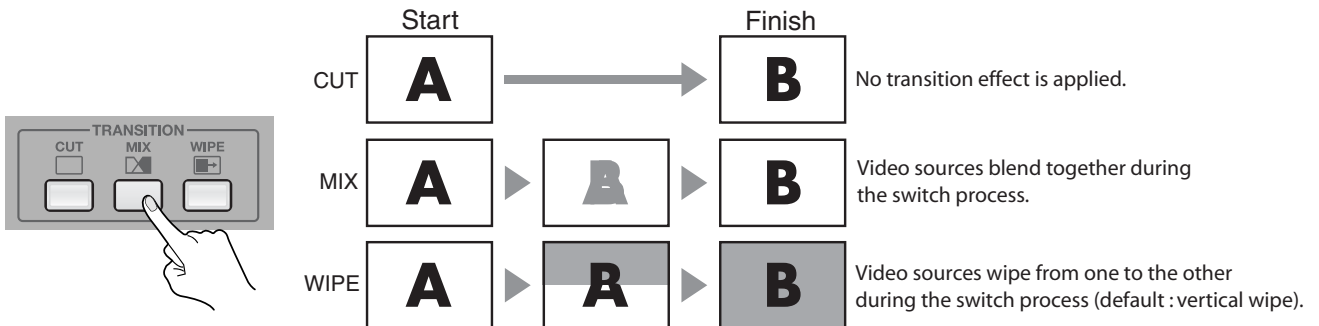

- The duration of the transition effect is set at 0.5 seconds by default.
- You can choose from eight types of wipe patterns.
- You can change the direction of the wipe, and also apply soft edges to the wipe.

MEMO

You can use the menus to modify the items just described and change the settings for the transition effect. Refer to "Menu Operations" (p. 44) and "VIDEO Menu" (p. 45).

3. Select a different channel.

Touch the touch panel and choose a channel other than the one currently selected (the channel displayed with a red border). If you selected [MIX] or [WIPE] in step 2, the transition effect is applied. The newly selected channel is displayed with a green border while the transition effect is being applied. When the transition effect is completed, the color of the border changes to red.

NOTE

During overlay display, the touch panel cannot be used to perform switching. Use the [VIDEO SELECT] buttons to switch.

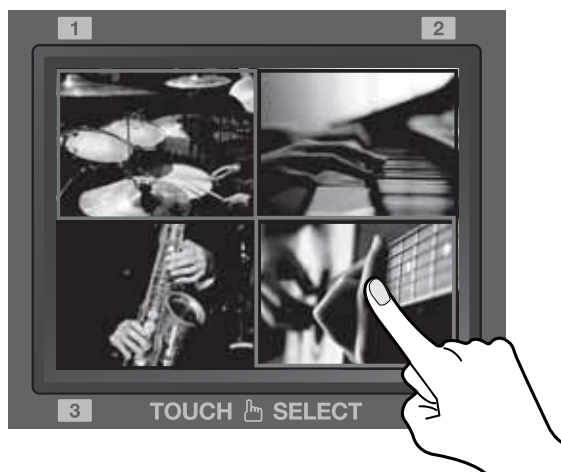

4. Check the output video.

At [MONITOR], press the [OUTPUT] button.

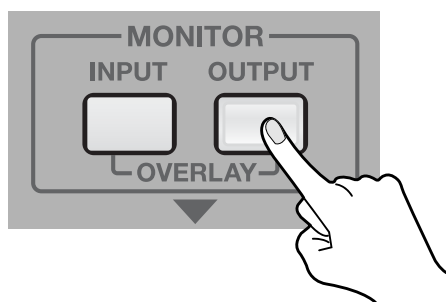

TIP

At [MONITOR], you can select OVERLAY mode by pressing the [INPUT] and [OUTPUT] buttons at the same time. In this mode, the output video overlays on the four-way split picture. This is useful when you want to check the input and output at the same time. You can also use the touch panel or [VALUE] dial to change the position of the output video. Refer to "Changing the Size and Position of Overlay Display" (p. 41).

Using Buttons to Switch the Video

Instead of using the touch panel, you can perform switching by pressing the [VIDEO SELECT] buttons ([1] through [4]).

The button indicator for the currently selected channel lights up in red. The indicator for the newly selected channel flashes green while a transition effect is applied. When the applied transition effect ends, the color of the indicator changes to red, and the indicator stops flashing and lights up steadily.

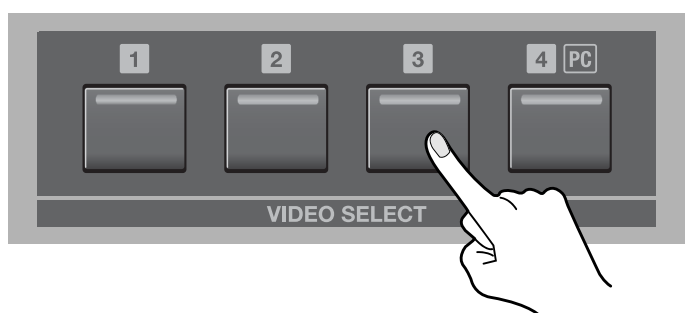

Automatically Switching the Video

At the [VIDEO] menu, going to [TRANSITION] and setting [CH SCAN] to [ON] causes the video on channels 1 through 4 to be switched automatically. Use [SCAN TIME] to adjust the display time for each respective channel. You can set the time at a value from 1 to 120 seconds. Refer to “Menu Operations” (p. 44) and “VIDEO Menu” (p. 45).

* Channels that have no video input will be skipped.

* When [CH SCAN] is set to [ON], switching channels manually is not possible.

Freezing the Final Output

You can use the [FREEZE] button to freeze the picture in the final output. Pressing the [FREEZE] button freezes the final output. Press the button again to return to normal output.



TIP

When you are changing the connections between two computers during output, freeze the output before disconnecting the first computer and then end the freezing after connecting the second computer. This allows you to keep an active PC image on the screen while the VR-3 locks to the new PC source.

Applying a Fade to Final Video Output

You can apply a fade-in or fade-out to the final output by operating the [OUTPUT FADE] dial. This applies a white or black fade-out at times when you want to suppress video output, such as during intervals in a band performance.

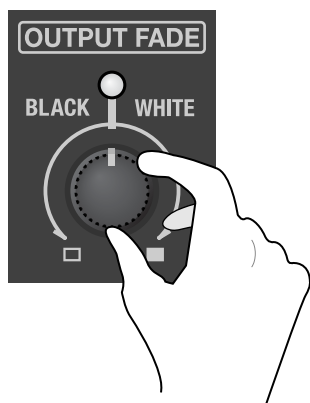

Fade Out

Turning the [OUTPUT FADE] dial clockwise applies a white fade-out, and turning the dial counterclockwise applies a black fade-out. Applying a fade makes the indicator above the dial flash.

Fade In

Return the [OUTPUT FADE] dial to its center position. The indicator stops flashing and lights steadily and your output video returns to normal.

Adjusting the Audio Balance

NOTE

When the [MASTER] fader is lowered all the way, no audio is output to the speakers or a computer connected via USB. For information on using the [MASTER] fader to adjust the final output, refer to "Adjusting the Final Audio Output" (p. 28).

Adjusting the Input Sensitivity and Stereo Position

Use the [GAIN] dials to adjust the input sensitivity and the [PAN] dial to adjust the stereo position.

1. Turn down the input sensitivity.

Before mixing your audio sources, first turn the [GAIN] dials counterclockwise to lower the input sensitivity.

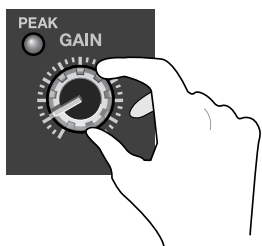

2. Raise the faders to the unity position.

Raise the faders for each channel to the unity position (the intermediate position in the area of close-set scale markings).

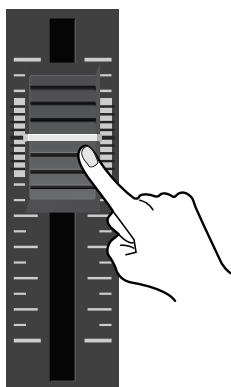

3. Check incoming audio.

Perform a sound check by having audio sent into your microphones or audio input source.

4. Adjust the input sensitivity.

Gradually turn the [GAIN] dials clockwise to increase the input sensitivity. Raise this just enough that the [PEAK] indicators do not light up when the output from the source is at maximum volume level.



NOTE

Turning the [GAIN] dials may produce a popping noise or cause momentary audio drop-out, but this is not a malfunction.

5. Adjusting the Stereo Position

Use the [PAN] dial to adjust the stereo position to the left or right.

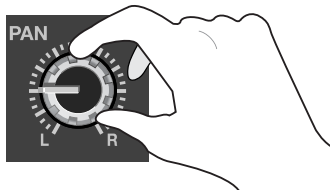

Adjusting the Tone

Use the [HI] dial and [LO] dial in the [EQ] section to adjust the tone.



1. Emphasize or attenuate the high band.

Turn the [HI] dial to emphasize or attenuate the high section.

2. Emphasize or attenuate the low band.

Turn the [LO] dial to emphasize or attenuate the low section.

Mixing Ambient Sounds into the Output

Using the internal microphones lets you mix the voices of nearby people or other ambient audio into the final output. The two internal microphones on the VR-3 are installed at the locations shown below. To adjust the level for the internal microphones, go to [INTERNAL MIC] and use the [LEVEL] dial.



NOTE

When the buttons and faders are operated, the internal microphones can pick up the sound of operation.

Adjusting the Volume Balance for Each Channel

Use the faders for 1 through 4 and for 5/6 to adjust the audio levels of the respective channels.

* When audio is input from a computer via the stereo mini connector, it is assigned to channels 7/8. Channels 7/8 have no fader, and the dial is used for adjustment.

1. Move the faders to the unity position.

For all channels that have input, move their faders to the unity position.

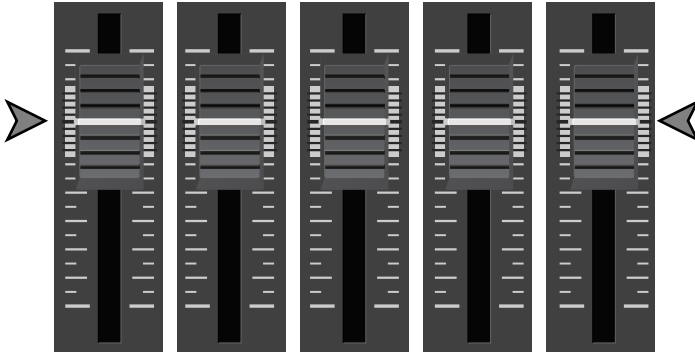

2. Select a channel you want to emphasize.

Select a channel you want to make more prominent, for example, the microphone used by a presenter. Leave the fader for that channel at the unity position.

3. Lower the volume levels of the other channels.

Leave the fader untouched for the channel you want to make prominent, and lower the faders for the other channels.

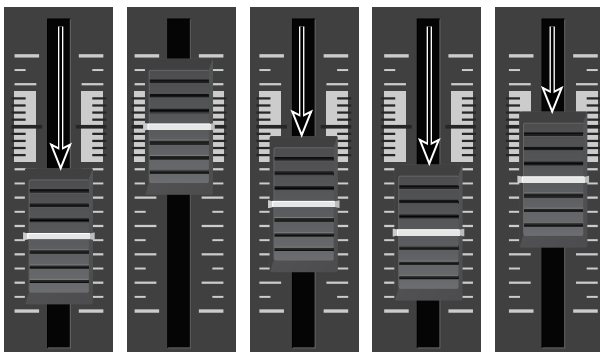

Adjusting the Final Audio Output

You can use the [MASTER] fader to adjust the volume level of the final output. Operate the fader while watching the [MASTER] indicator.

1. Check the volume level of the final output.

See the [MASTER] indicator to check the volume level. If [OVER] lights up, the volume level may be excessive, resulting in distortion. If only the indicators up to [-48] or [-30] light up, the volume level may be insufficient. This might worsen the signal-to-noise ratio, resulting in poor-quality speaker output.

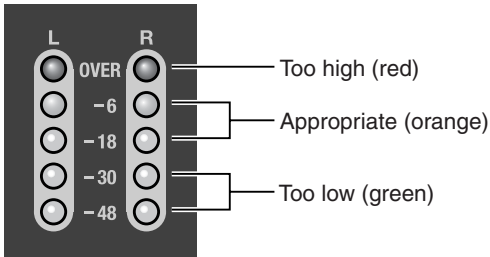

2. Adjust the volume level.

Move the [MASTER] fader to adjust the volume level. A suitable level is where [-18] to [-6] light up at maximum input.

* If the volume level of speaker output is not suitable even after adjustment so that [-18] to [-6] light up, adjust the volume for the speakers or the amplifier. Using the [MASTER] fader to carry out further adjustment might result in distortion or degradation of sound quality.

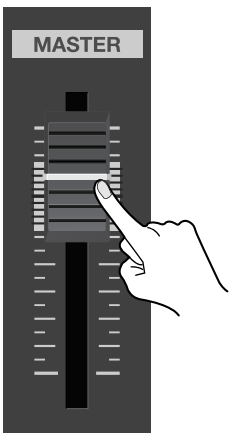

3. Apply reverb.

Turn the [REVERB] dial to adjust the amount of reverb.



NOTE

When reverb has been switched off via the menu, no reverb is applied regardless of where the dial is set. Go to the [AUDIO] menu, and at [REVERB], set [REVERB SW] to [ON]. Refer to "AUDIO Menu" (p. 46).

NOTE

Excessive reverb may cause feedback/howling to the final output.

TIP

Using the menus (p. 44), you can adjust the amount of reverb on each channel individually. Go to the [AUDIO] menu and use [REVERB SEND] to adjust the amount of reverb. Refer to "AUDIO Menu" (p. 46).

Compositing the Picture

Compositing Using Picture-in-Picture

Compositing that displays an inset screen on a background is called "Picture-in-Picture" (PinP).

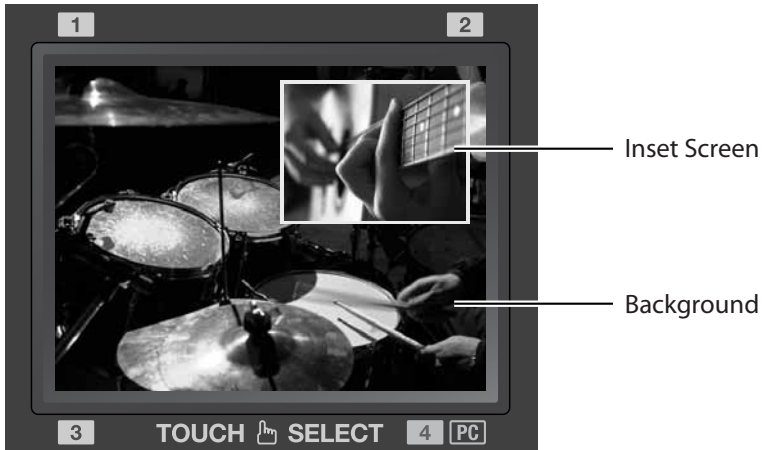

* By default, no shadows are added to the inset screen, but you can use the menus to add them. Go to the [VIDEO] menu, and at [PinP], adjust the setting value for [SHADOW]. Refer to "Menu Operations" (p. 44) and "VIDEO Menu" (p. 45).

* By default, a white border is applied. You can use the menus to change the color and width. Go to the [VIDEO] menu, and at [PinP], adjust the setting values for [BORDER] and [BORDER COLOR]. Refer to "Menu Operations" (p. 44) and "VIDEO Menu" (p. 45).

* By default, the size of the inset screen is about one-third the size of the background, both vertically and horizontally. For information on adjusting the position and size of the inset screen, refer to the following section, "Adjusting the Position and Size of the Inset Screen."

1. On the monitor, display the inputs from the sources.

At [MONITOR], press the [INPUT] button.

2. Select the PinP mode.

Go to [COMPOSITION] and press the [PinP] button to make it light up. [VIDEO SELECT] buttons [1] through [4] all simultaneously flash in green.

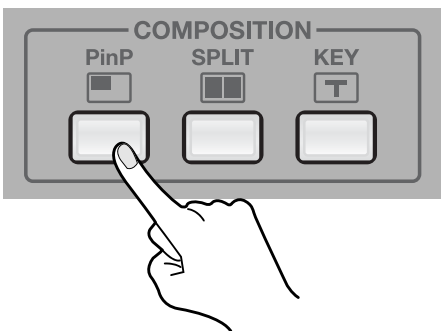

3. Select the background.

Use the touch panel to choose the channel for the background. A red border appears around the selected channel.



4. Select the inset screen.

Use [VIDEO SELECT] buttons [1] through [4] to choose the channel for the inset screen. The indicator for the selected channel lights up in green. Also, a green border appears around the selected channel on the touch panel.

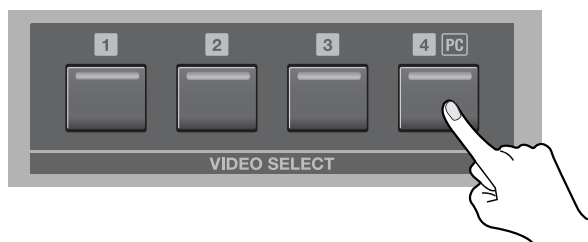

5. Check the compositing results on the monitor.

At [MONITOR], press the [OUTPUT] button. You can now use the built-in monitor to check the results of compositing.

6. Make the inset screen disappear.

Go to [COMPOSITION] and press the [PinP] button again to make it go dark. When it goes dark, the inset screen disappears.

NOTE

While compositing, no transition effect (MIX or WIPE) can be applied.

MEMO

The duration of the fade when the inset screen appears or disappears is the time set for transition effects. By default, this is set at 0.5 seconds. You can use the menus to change the time. Go to the [VIDEO] menu, and at [TRANSITION], adjust the setting value for [TRANSITION TIME]. Refer to "Menu Operations" (p. 44) and "VIDEO Menu" (p. 45).

MEMO

You can also make a setting that automatically selects the channel for the previously selected inset screen when the [PinP] button is pressed again. Go to the [VIDEO] menu, and at [PinP], set [PREVIOUS SELECT] to [ON]. Refer to "VIDEO Menu" (p. 45).

Adjusting the Position and Size of the Inset Screen

You can use the touch panel to adjust the position and size of the inset screen.

1. Display the output picture on the monitor.

At [MONITOR], press the [OUTPUT] button.

2. Move the position of the inset screen.

Touch the inset screen and slide your finger over the touch panel.

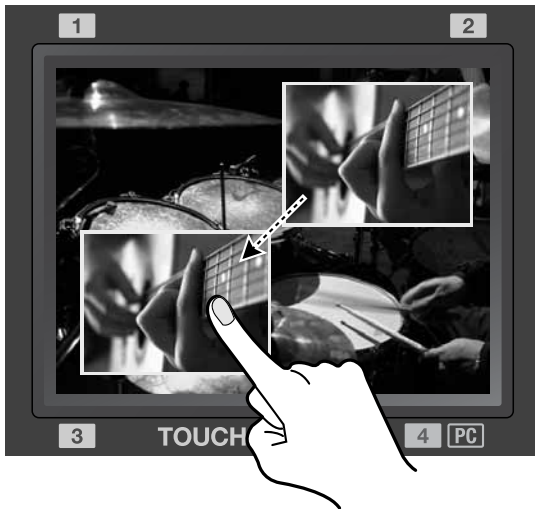

3. Change the size of the inset screen.

While the inset screen is displayed, turn the [VALUE] dial. Turning the dial counterclockwise reduces the size, and turning the dial clockwise expands it.

* You can expand or reduce the size rapidly by pressing in the [VALUE] dial as you turn it.

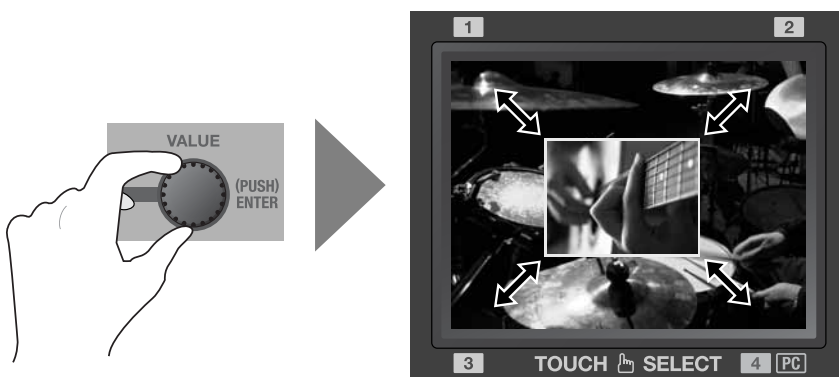

NOTE

When the [FREEZE] button is illuminated and final output is frozen, operations using the touch panel or the [VALUE] dial have no effect. Make the [FREEZE] button go dark to end the frozen output before such operations.

Compositing Using Split

The four split composition patterns described below are available on the VR-3.

* The names of the menu items are shown below. By default, "V. CENTER" is selected as the split pattern. You can use the menus to change this to a different pattern. At the [VIDEO] menu, go to [SPLIT] and select [PATTERN]. Refer to "Menu Operations" (p. 44) and "VIDEO Menu" (p. 45).

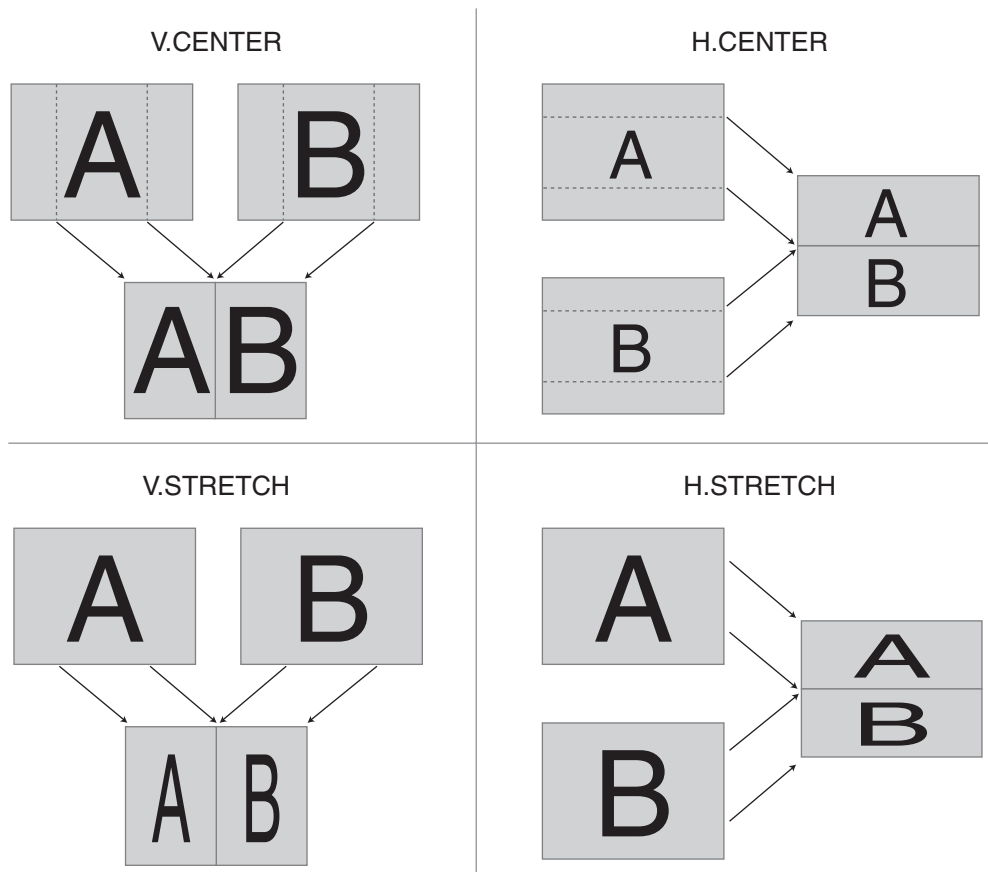

MEMO

With [V. CENTER] and [H. CENTER], you can use the menus to adjust the extraction locations (the center positions for A and B). Go to the [VIDEO] menu, and at [SPLIT], adjust the setting values for [A-CENTER] and [B-CENTER]. Refer to "Menu Operations" (p. 44) and "VIDEO Menu" (p. 45).

* When [V. STRETCH] or [H. STRETCH] is selected as the split pattern, the center locations and the [SOFT EDGE] value cannot be adjusted.

Under the default settings (V. CENTER and center cropping), you can carry out compositing like that shown below.

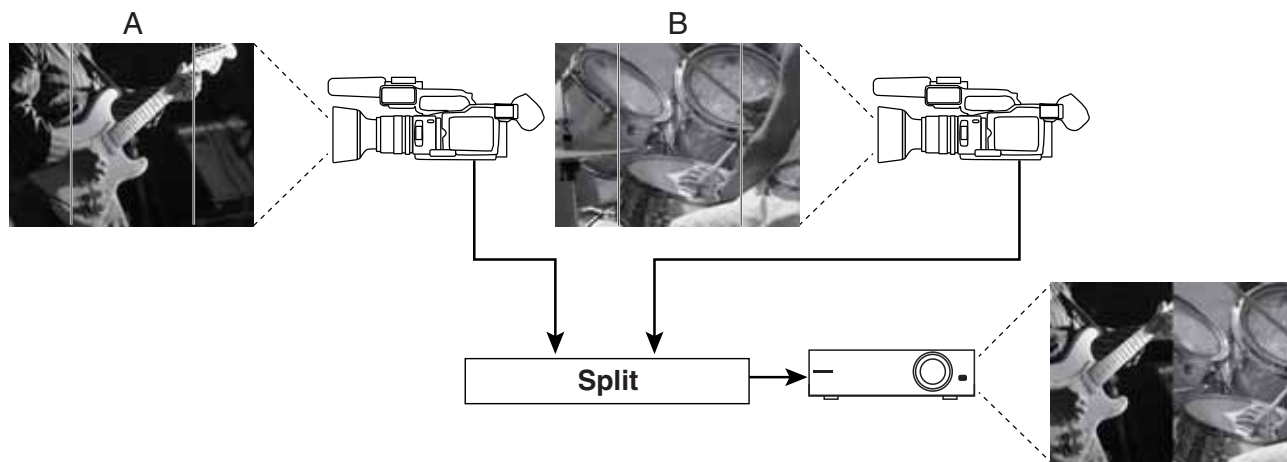

1. On the monitor, display the inputs from the sources.

At [MONITOR], press the [INPUT] button.

2. Select the split mode.

Go to [COMPOSITION] and press the [SPLIT] button to make it light up. [VIDEO SELECT] buttons [1] through [4] all simultaneously flash in green.

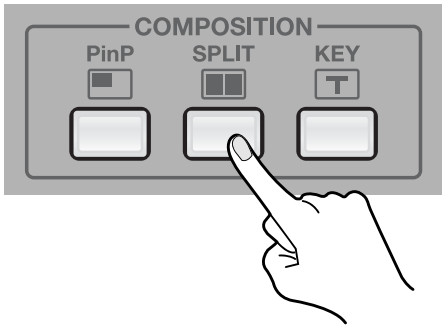
**3. Select the channel to display on side A.**

Use the touch panel to choose the channel to display on side A. A red border appears around the selected channel.

4. Select the channel to display on side B.

Use the [VIDEO SELECT] buttons to choose the channel to display on side B. A green border appears around the selected channel. The indicator of the button also lights up in green.

* When the same channel is selected for side A and side B, only the red border is displayed.

5. Check the compositing results on the monitor.

At [MONITOR], press the [OUTPUT] button. You can use the built-in monitor to check the results of compositing.

6. Quit the split view.

Go to [COMPOSITION] and press the [SPLIT] button again to make it go dark. When it goes dark, the screen on side B disappears.

NOTE

While compositing, no transition effect (MIX or WIPE) can be applied.

MEMO

If [PREVIOUS SELECT] is turned on, the unit automatically selects the channels previously assigned for side A and side B when the [SPLIT] button is pressed again. Go to the [VIDEO] menu, and at [SPLIT], set [PREVIOUS SELECT] to [ON]. Refer to "VIDEO Menu" (p. 45).

Compositing Using Luminance Key/Chroma Key

Compositing Using Luminance Key

Luminance key enables you to superimpose logos or text on a background picture. In this section, the RGB input from a computer (channel 4) is composite over the video on channels 1 through 3.

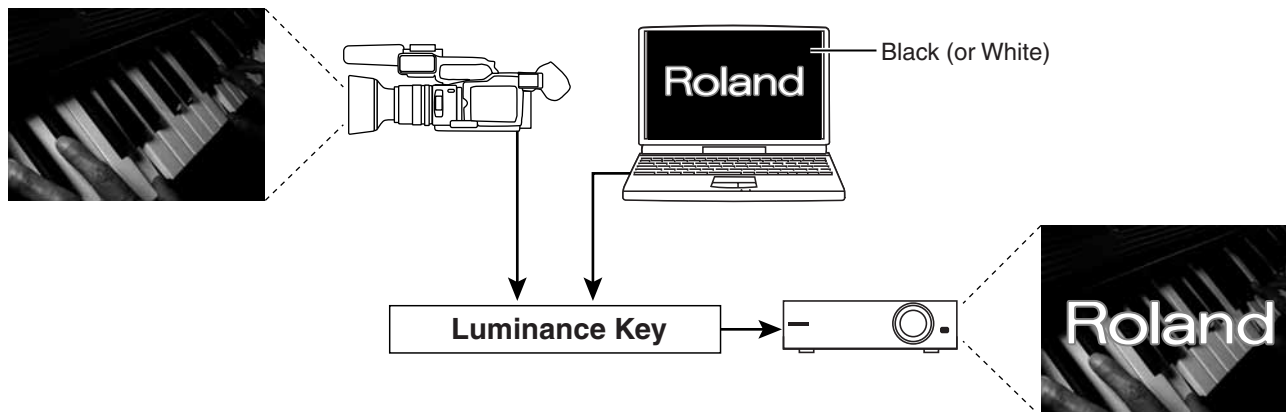

When using luminance key, you can specify either black or white as the extraction color. By default, black is extracted. You can attractively composite a white logo or text on a black background, as shown in the figure above.

MEMO

You can use the menus to change the extraction color to white. Go to the [VIDEO] menu, and at [KEY], set [LUMI KEY COLOR] to [WHITE]. Refer to "Menu Operations" (p. 44) and "VIDEO Menu" (p. 45).

1. On the monitor, display the inputs from the sources.

At [MONITOR], press the [INPUT] button.

2. Select the key mode.

Go to [COMPOSITION] and press the [KEY] button to make it light up. [VIDEO SELECT] buttons [1] through [4] all simultaneously flash green.

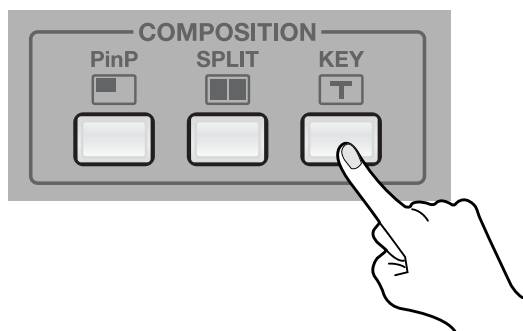

3. Select the background.

Use the touch panel to choose the channel for the background. A red border appears around the selected channel.

4. Select the channel to display in the foreground.

Use [VIDEO SELECT] buttons [1] through [4] to choose the channel to display in the foreground. The indicator for the selected channel lights up in green. Also, a green border appears around the selected channel on the touch panel.

* When inputting a logo or text from a computer using RGB, choose channel 4.

5. Adjust the degree of extraction.

Turn the [KEY-LEVEL] dial clockwise, toward [LUMI KEY], to adjust the amount of extraction. At the center position, complete extraction occurs, and only the background is visible. Turn the dial clockwise to find a position that yields an optimal degree of extraction.

**6. Check the compositing results on the monitor.**

At [MONITOR], press the [OUTPUT] button. You can use the built-in monitor to check the results of compositing.

7. Remove the foreground picture.

Go to [COMPOSITION] and press the [KEY] button again to make it go dark. When it goes dark, the logo or text disappears.

NOTE

The duration of the fade during which the foreground picture appear or disappear is the time set for transition effects. By default, this is set at 0.5 seconds. You can use the menus to change the time. Go to the [VIDEO] menu, and at [TRANSITION], adjust the setting value for [TRANSITION TIME]. Refer to "Menu Operations" (p. 44) and "VIDEO Menu" (p. 45).

Compositing Using Chroma Key

Chroma key composites the video image shot with blue-back/green-back on a different background video.

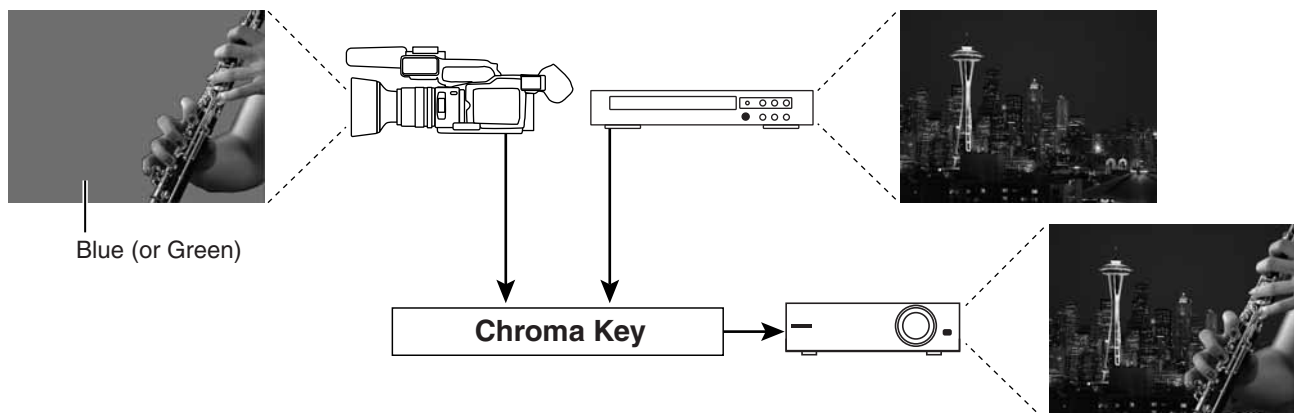

When using chroma key, you can specify either blue or green as the extraction color. By default, blue is extracted.

MEMO

You can use the menus to change the extraction color to green. Go to the [VIDEO] menu, and at [KEY], set [CHROMA KEY COLOR] to [GREEN]. Refer to "Menu Operations" (p. 44) and "VIDEO Menu" (p. 45).

1. On the monitor, display the inputs from the sources.

At [MONITOR], press the [INPUT] button.

2. Select the key mode.

Go to [COMPOSITION] and press the [KEY] button to make it light up. [VIDEO SELECT] buttons [1] through [4] all simultaneously flash in green.

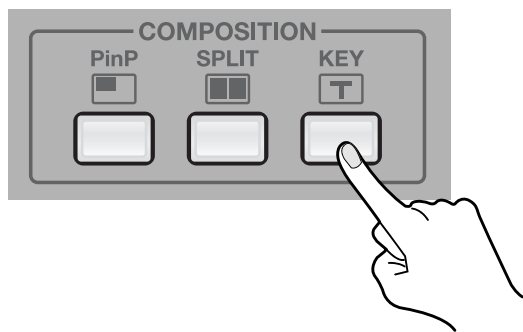

3. Select the background.

Use the touch panel to choose the channel for the background. A red border appears around the selected channel.

4. Select the channel to display in the foreground.

Use the [VIDEO SELECT] buttons to choose the channel to display in the foreground. A green border appears around the selected channel. The indicator of the pressed button also lights up in green.

5. Adjust the degree of extraction.

Turn the [KEY-LEVEL] dial clockwise, toward [CHR KEY], to adjust the amount of extraction. At the center position, complete extraction occurs, and only the background is visible. Turn the dial counterclockwise to find a position that yields an optimal degree of extraction.



6. Check the compositing results on the monitor.

At [MONITOR], press the [OUTPUT]. You can use the built-in monitor to check the results of compositing.

7. Remove the foreground picture.

Go to [COMPOSITION] and press the [KEY] button again to make it go dark. When it goes dark, the picture displayed in the foreground disappears.

NOTE

While compositing, no transition effect (MIX or WIPE) can be applied.

NOTE

Some amount of blue/green color may remain around the edge of foreground image and some noise may be found. But this is not a malfunction.

MEMO

The duration of the fade during which the foreground picture appears or disappears is the time set for transition effects. By default, this is set at 0.5 seconds. You can use the menus to change the time. Go to the [VIDEO] menu, and at [TRANSITION], adjust the setting value for [TRANSITION TIME]. Refer to "Menu Operations" (p. 44) and "VIDEO Menu" (p. 45).

MEMO

If [PREVIOUS SELECT] is turn on, the unit automatically selects the channels previously assigned for background and foreground when the [KEY] button is pressed again. Go to the [VIDEO] menu, and at [KEY], set [PREVIOUS SELECT] to [ON]. Refer to "VIDEO Menu" (p. 45).

Performing Output from the USB Port

Connecting a Computer

You can connect a computer to the USB port on the VR-3 and output the results of video and audio mixing.

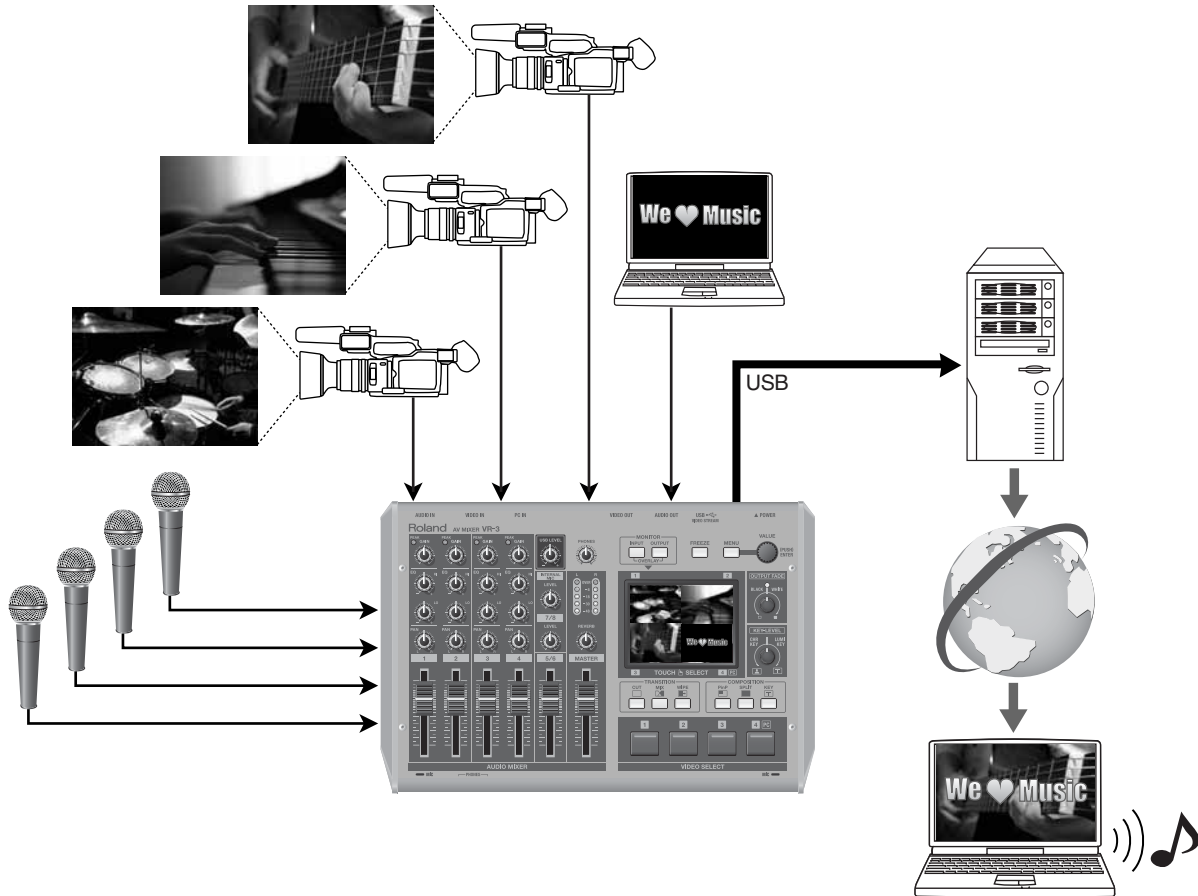

Supported Operating Systems

You can make connections to computers running the following operating systems.

- Windows XP Home Edition/Professional Edition Service Pack 3 or later
- Windows Vista Service Pack 2 or later
- Windows 7
- Mac OS X 10.6 or later

* Connection and operation of the VR-3 with standard computers running the operating systems described above have been verified, but connection and operation with all computers satisfying such conditions is not assured. Connection or operation may be impossible due to differences in setting specifications or the usage environment that are specific to the equipment.

Making the Connection to a Computer

To make the connection to a computer, carry out the steps described below.

1. Connect a computer.

After starting the VR-3 and the operating system on the computer, use the included USB cable to connect the USB port on the VR-3 to a USB port on the computer.

* Making the connection via an extension cable or USB hub may result in failure of the computer to detect the VR-3. Connect the VR-3 and computer directly.

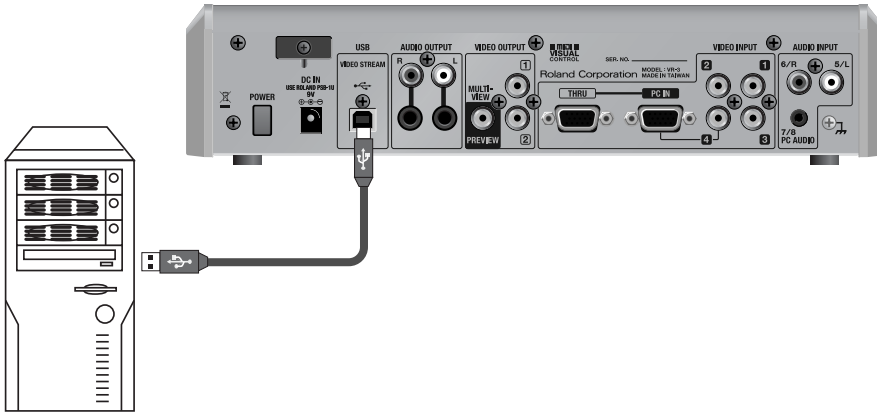

2. Wait for communication between the VR-3 and the computer to be established.

A short while after making the USB connection, communication with the computer starts, and the standard driver for the operating system is automatically installed. Installing a special driver is not necessary.

* The computer recognizes the VR-3 as a USB video device/audio device.

Performing Output to a Computer

For the video and audio signals from the VR-3 to be viewed and heard correctly on the computer, software that supports USB video class and USB audio class must be installed and set up on the computer.

1. Prepare output of video or audio.

Operate the VR-3 to prepare the video and audio output for the computer.

2. On the computer, check the input from the VR-3.

Start the program that supports USB video class/audio class, and check the video or audio input from the VR-3.

3. Adjust the output level of the audio.

You can adjust the level of the audio output to the computer by turning the [USB LEVEL] dial.

* When the dial is at the center position, the USB output level is same as analog output.



TIP

You can use the menus to apply delay to the audio output from the USB connector and align the timing of the video and the audio. On the VR-3, you can set the amounts of delay separately for the USB output and the analog output. Go to the [SYSTEM] menu, and at [AUDIO DELAY], adjust the values for [ANALOG OUT DELAY] and [USB OUT DELAY]. Refer to "Menu Operations" (p. 44) and "SYSTEM Menu" (p. 47).

Output Signals

The following signals are output from the USB port on the VR-3.

- Video 720 x 480 pixels (when set to NTSC) or 720 x 576 pixels (when set to PAL)/Motion JPEG
- Audio 16 bits/48 kHz/linear PCM

USB Video Filter

Using the menus to switch on the USB video filter lets you perform interpolation on the USB video output. At "SYSTEM Menu" (p. 47), set [USB VIDEO FILTER] to [ON].

* The analog output from is not affected.

* Applying the filter to video that has rapid motion can produce horizontal stripes in the picture. If this is a concern, set [USB VIDEO FILTER] to [OFF].

Using Other Features

Changing the Size and Position of Overlay Display

When overlay display has been enabled by simultaneously pressing the [INPUT] and [OUTPUT] buttons in the [MONITOR] section, turning the [VALUE] dial changes the size of the display. Turning the dial counterclockwise reduces the size, and turning the dial clockwise expands it.

* You can expand or reduce the size rapidly by pressing in the [VALUE] dial as you turn it.

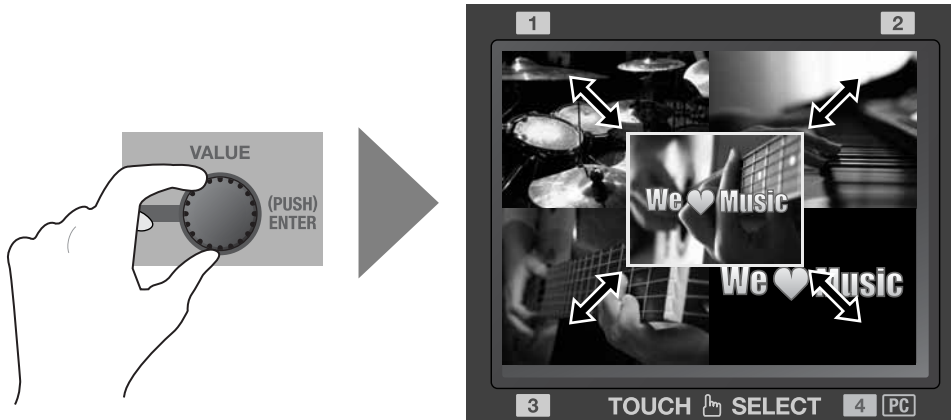

You can also change the display position by touching screen. Touch the overlay display and slide your finger over the touch panel.

NOTE

During overlay display, the touch panel cannot be used for video switching. Use the [VIDEO SELECT] buttons to switch. You can quit the overlay display by pressing the [INPUT] or [OUTPUT] button.

NOTE

You can use the menus to darken the background screen (four-way split screen). Go to the [SYSTEM] menu and adjust the setting value of [BCKGRD LEV - OVERLAY]. Refer to "Menu Operations" (p. 44) and "SYSTEM Menu" (p. 47).

Applying Effects to Audio

In addition to reverb, you can apply the effects described below to the audio.

For Input

- HIGH PASS This cuts the low band, passing only the high band. This is effective to remove low-frequency noise.
- NOISE GATE This attenuates signals below a certain level. Use it when you want to suppress unnecessary sounds.
- EQ Hi/Lo This applies an equalizer to channels that have no dials on the top panel (5/6, 7/8, and the internal microphones).

For Output

- NOISE SUPPRESSOR This cancels signals during times of no input, for output of clear audio.
- ENHANCER This adds harmonics to adjust or accent the tone quality.
- MASTER Hi/Lo This adjusts the tone of the final output

* To apply effects to output, the value of "MASTERING FX SW" must be set to [ON].

MEMO

In addition to the effects just described, you can apply [AUDIO DELAY] to delay audio output in order to align the timing of the video and the audio. On the VR-3, you can set the amount of delay independently for analog output and USB output. Go to the [SYSTEM] menu, and at [AUDIO DELAY], adjust the setting values for [ANALOG OUT DELAY] and [USB OUT DELAY]. Refer to "SYSTEM Menu" (p. 47).

1. Access the menu.

Press the [MENU] button to display the menu on the monitor.

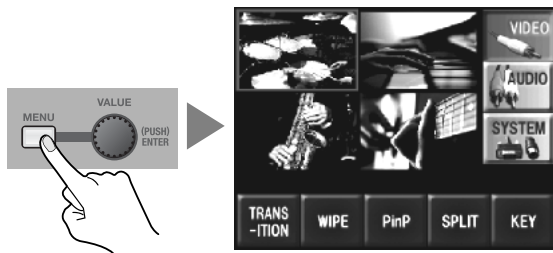

2. Display the AUDIO menu.

Touch the [AUDIO] icon on the right side to display audio-related menus.



3. Select the target for the effect.

Touch the icons arranged along the bottom of the screen to choose the target for applying the effect. You can select one from below.

- [1-4] Select this when you want to apply the effect to the input on channels 1 through 4.
- [5-8 INT MIC] Select this when you want to apply the effect to the input on channels 5 through 8 or to the audio from the internal microphones.
- [MASTERING] Select this when you want to apply the effect to the output.

* For [REVERB] and [REVERB SEND], you can use the menus to fine-tune the parameters for reverb. Refer to “Menu Operations” (p. 44) and “AUDIO Menu” (p. 46).

4. Select the channel and the effect.

Choose the channel and the effect to apply to it. For example, to apply HIGH PASS on channel 3, select [HIGH PASS / IN 3], then turn the [VALUE] dial to change the setting to [ON].

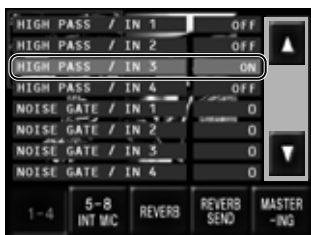

5. Adjust the amount of effect applied.

When you have selected NOISE GATE, EQ, or other effect whose setting is adjustable, turn the [VALUE] dial to adjust it. You can apply the setting value by pressing the dial.

* You can change a setting value up or down by ten units at a time by holding the [VALUE] dial depressed as you turn it.

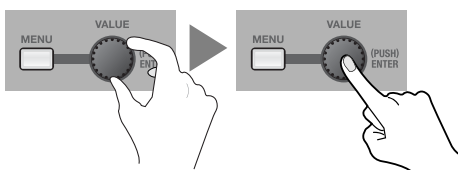

6. Go back to the original screen.

Press the [MENU] button once to return to the screen called up in step 1. Press the [MENU] button once more to make the menu display disappear.

* The settings of the menu items are saved to the internal memory while you are closing the menu screen.

Saving/Recalling Settings

The [MEMORY] item at the [SYSTEM] menu lets you save and call up the panel state and various settings.

* The settings of these items are saved to the internal memory while you are closing the menu screen.

- **SAVE SETTING** This saves the current settings and panel state to the internal memory.
- **LOAD SETTING** This calls up saved settings and panel state.
- **POWER ON LOAD** This automatically calls up saved settings and panel state at startup.

MEMO

You can save eight sets of settings to the internal memory. Use [SAVE SETTING], [LOAD SETTING], and [POWER ON LOAD] to select a number from 1 to 8.

Returning to the Factory-default State

This returns various settings to their factory defaults.

1. Access the menu.

Press the [MENU] button to access the menu screen.

2. Display the SYSTEM menu.

Touch the [SYSTEM] icon to display system-related menus.

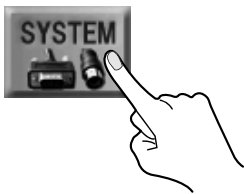

3. Select [Factory Reset].

Choose [SETUP] to display various setting menus. Then select [FACTORY RESET].



4. Return the unit to its factory-default state.

Selecting [FACTORY RESET] makes a confirmation screen appear. Pressing the [VALUE] dial at the confirmation screen returns the unit to its factory-default state.

Returning the unit to its factory-default state also deletes all settings saved to internal memory.

Switching Between NTSC and PAL

Go to the [SYSTEM] menu and use [NTSC/PAL] to select [NTSC] or [PAL]. Restart the VR-3 to switch NTSC/PAL

NOTE

Images will not be display correctly if the setting on the VR-3 differs from the signals of the connected external equipment.

Menu Operations and Menu List

Menu Operations

Use the [MENU] button and the [VALUE] dial, or the touch screen to make various settings.

1. Access the menu.

Press the [MENU] button to call up the menu screen on the monitor. Displayed first is the top menu screen. From here, you can move to the screens for various items.



When you want to display only the menus and hide the video preview, go to the [MONITOR] section and make both the [INPUT] and [OUTPUT] button go dark.

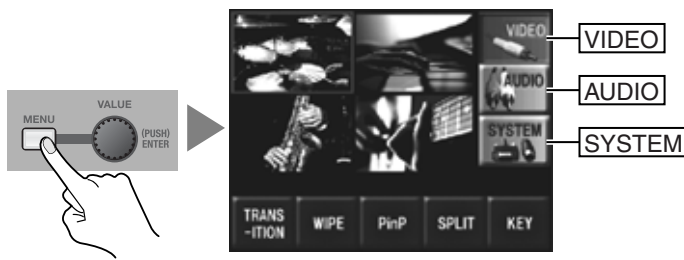

2. Select the setting item (1).

Touch the icons arranged along the right side of the screen to select the item whose setting you want to make from [VIDEO], [AUDIO] or [SYSTEM].

* You can also select an item by turning and pressing the [VALUE] dial.

3. Select the setting item (2).

Touch the icons arranged along the bottom of the screen to choose the item to set. As an example, for [VIDEO], select from below.

* You can also select an item by turning and pressing the [VALUE] dial.

- TRANSITION This sets values such as transition time.
- WIPE This selects the wipe pattern.
- PinP This specifies the display location and size of the inset screen, and the values for edge, shadow, or others.
- SPLIT This specifies the split pattern or other detailed settings for split.
- KEY This specifies the key color or other detailed settings for chroma/luminance key.

4. Select a parameter.

Selecting an item in step 3 displays a list of the parameters.

* Depending on the item, the screen may not be able to display all parameters as one time. In such cases, touch the up and down cursor shown below to scroll the display.

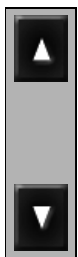

5. Change the setting value.

Selecting a parameter and turning the [VALUE] dial changes the setting value. Press the dial to apply the setting.

* You can change a setting value up or down by 10 units at a time by pressing down the dial as you turn it.

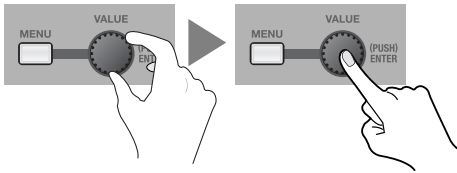

6. Go back to the original screen.

Press the [MENU] button once to return to the screen called up in step 1. Press the [MENU] button once more to make the menu display disappear.

* The settings of the menu items are saved to the internal memory while you are closing the menu screen.

Menu List

VIDEO Menu

Here you make various settings related to video transitions and compositing.

	TRANSITION	TRANSITION TIME	This sets the length of time for transition effects.
		CH SCAN	This toggles automatic switching on and off.
		SCAN TIME	This sets the length of time for automatic switching.
	WIPE	DIRECTION	This selects the wipe direction.
		SOFT EDGE	This switches soft edges for wipe on and off.
		PATTERN	This selects the wipe pattern.
	PiP	H.POSITION	This adjusts the horizontal position of the inset screen.
		V.POSITION	This adjusts the vertical position of the inset screen.
		4:3 HV.SIZE	This adjusts the size of inset screen keeping aspect ratio at 4:3.
		H.SIZE	This adjusts the horizontal size of the inset screen.
		V.SIZE	This adjusts the vertical size of the inset screen.
		BORDER	This adjusts the width of the border added to the inset screen.
		BORDER COLOR	This selects the color of the border added to the inset screen.
		SHADOW	This adjusts the width of the shadow added to the inset screen.
		SHADOW COLOR	This selects the color of the shadow added to the inset screen.
TRIMMING		This adjusts the trimming width of the inset screen.	
PREVIOUS SELECT	This applies the previously set values for the inset screen.		
SPLIT	A-CENTER	This moves the side-A center position.	
	B-CENTER	This moves the side-B center position.	
	SOFT EDGE	This applies a soft edge to the split portion.	
	PATTERN	This selects the split pattern.	
	PREVIOUS SELECT	This applies the previously selected pattern and settings.	
KEY	CHROMA KEY COLOR	This selects the extraction color for chroma key.	
	CHROMA KEY EDGE	This adjusts the degree of edge blur for chroma key.	
	LUMI KEY COLOR	This selects the extraction color for luminance key.	
	LUMI KEY EDGE	This adjusts the degree of edge blur for luminance key.	
	PREVIOUS SELECT	This applies the previously selected key and settings.	

AUDIO Menu

Here you make settings related to audio effects.

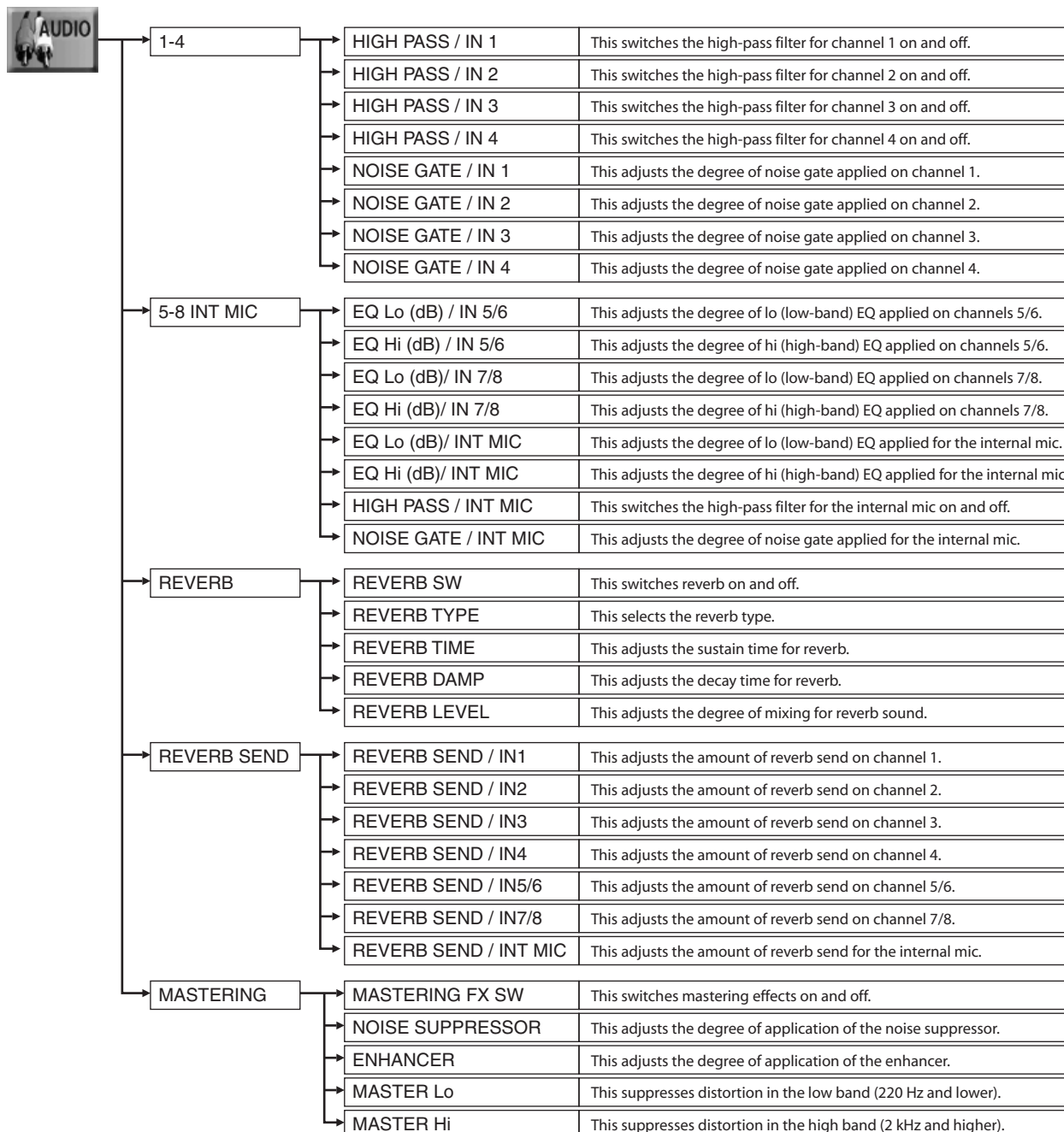

SYSTEM Menu

Here you make various system settings for the VR-3.

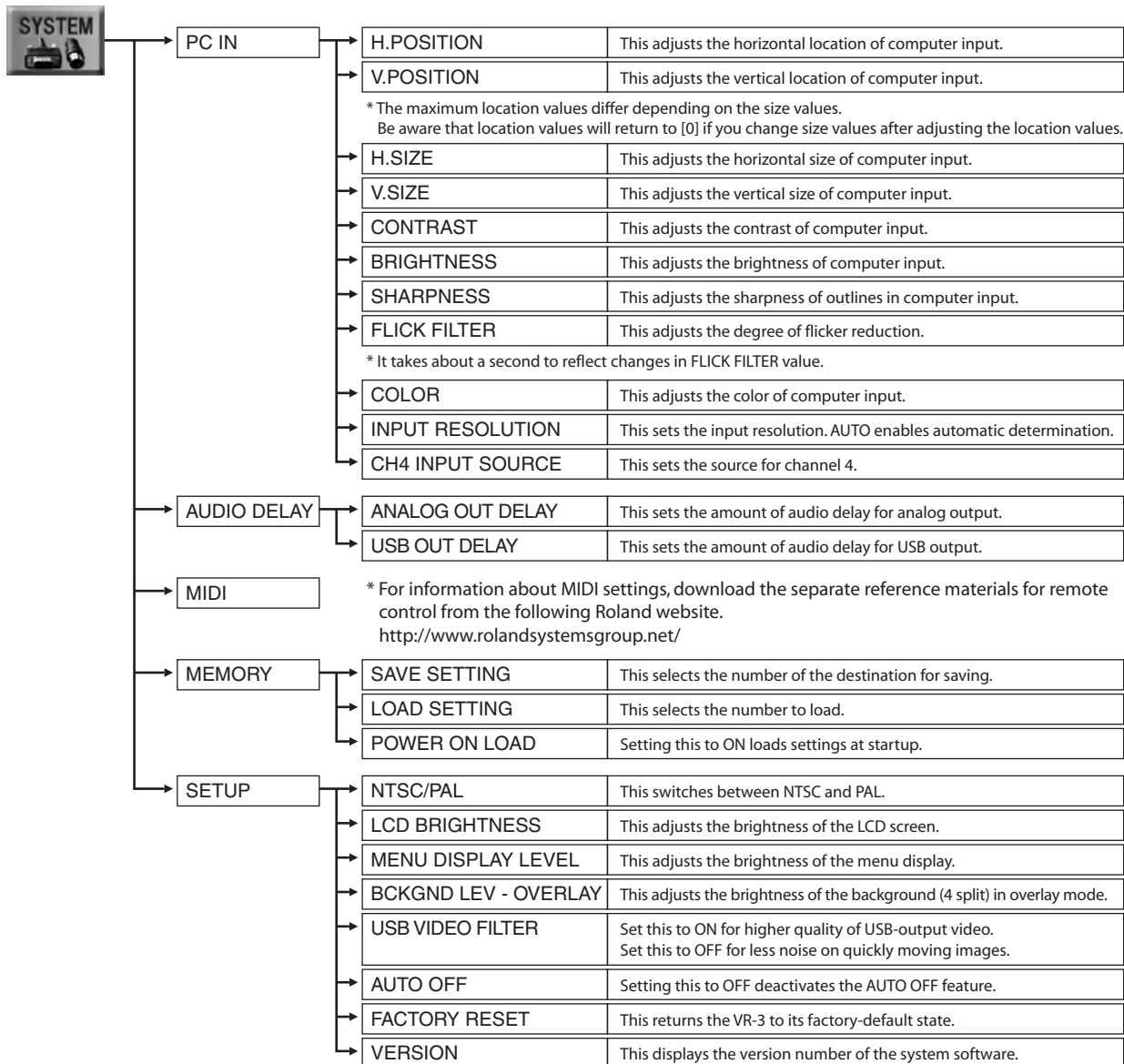

Appendices

Main Specifications

Video Processing			Input Level and Impadance	
Format	Video	NTSC/PAL (ITU601)	Video	1.0 Vp-p, 75 ohms
	PC-RGB	800 x 600/120 Hz, 832 x 624/75 Hz, 1024 x 768/80 Hz, 1152 x 864/75 Hz, 1152 x 870/75 Hz, 1280 x 720/60 Hz, 1280 x 768/75 Hz, 1280 x 800/75 Hz, 1280 x 1024/75 Hz, 1366 x 768 /75 Hz (RGB VH : Positive Logic/Negative Logic) * Conforms to VESA DMT Ver 1.0 Revision 10 * The refresh rate is the maximum value of each resolution.	PC-RGB	0.7 Vp-p, 75 ohms (H,V:5V TTL)
Sampling	13.5 MHz, 4:2:2 (Y:R-Y:B-Y), 8 bits		Audio Input Impedance	XLR/TRS : 4 k ohms RCA/PC INPUT : 15 k ohms
Frame Synchronizer	Built-in x 4		Audio Input Level	XLR/TRS - 68 to + 4 dBu Max Input Level : + 22 dBu
Audio Processing			RCA	-10 dBu, Max Input Level : + 8 dBu
Sampling	24 bits / 48 kHz		PC INPUT	-15dBu, Max Input Level : + 3 dBu
Input Connectors			Output Level and Impadance	
Video	Composite (RCA pin type) x 4		Video	1.0 Vp-p, 75 ohms
Audio	XLR/TRS combo type x 4 RCA pin type x 1 pair (L/R) Stereo mini type x 1 Built-in stereo mic x 1 pair (L/R)		Audio Output Impedance	Final Out : 1 k ohms PHONES : 10 ohms
PC-RGB	HD DB-15 type x 1 * If video is simultaneously input to Ch 4, PC-RGB takes priority.		Audio Output Level	Final Out - 10 dBu, Max Output Level : + 8 dBu
Output Connectors			PHONES	25mW + 25mW
Video	Final Out	Composite (RCA pin type) x 2	Effects	
	Preview	Composite (RCA pin type) x 1	Video	Transition Cut, Mix, Wipe
Audio	Final Out	Standard type x 1 pair (L/R) RCA pin type x 1 pair (L/R)	Composition	Luminance Key, Chroma Key, Picture in Picture, Split
	PHONES	Standard type x 1, Stereo mini type x 1	Audio	Input High Pass, Noise Gate, EQ (Hi/Lo)
PC-RGB (Thru out)	HD DB-15 type x 1		Output	Noise Suppressor, Enhancer, Master (Hi/Lo), Audio Delay, Reverb
Other Connectors			Others	
Remote Control	MIDI IN (5 pin DIN type) x 1 MIDI OUT/THRU (5 pin DIN type) x 1		Display	320 x 240 dots TFT color touch screen
USB	B type x 1 * Supports USB 2.0 Hi-Speed		Power Supply	DC 9 V (AC adaptor)
			Current Draw	1.5 A
			Dimensions	303 (W) x 202.7 (D) x 80.3 (H) mm 11-15/16 (W) x 8 (D) x 3-3/16 (H) inches
			Weight (excl. AC adaptor)	2.0 kg / 4 lbs 7 oz
			Accessories	AC adaptor and power cord, USB cable (A type - B type) x 1, Owner's manual

In the interest of product improvement, the specifications and/or appearance of this unit are subject to change without prior notice.

About Remote Control

The VR-3 can be operated remotely from an external MIDI device. For more information about remote control, download the separately available reference document from the following Roland website.

<http://www.roland.co.jp/solution/>



The VR-3 can be operated remotely from a device that supports MIDI Visual Control. MIDI Visual Control is a feature that uses MIDI to link visual expression to a musical performance.

Troubleshooting

No picture is output from the projector.

Is the [OUTPUT FADE] dial centered?

A fade is applied to output if the dial is turned either clockwise or counterclockwise. When performing output, adjust the dial to center. The indicator above the dial lights up when the dial is at center. The indicator flashes when the dial has been turned either clockwise or counterclockwise.

No microphone audio is output, even when the faders are raised.

Have the [GAIN] dials been turned to appropriate positions?

When input sensitivity has been lowered, no audio is output even when the faders are raised.

Is the connected microphone a condenser mic?

When you connect a condenser microphone that requires power supply, set the [PHANTOM] switch to ON.

Transition effects are not applied.

Is the length of time for transition effects (TRANSITION TIME) set at zero?

When the time is set at zero, no transition effects are applied even when [MIX] or [WIPE] is selected.

A logo cannot be input from a computer.

Is the RGB output from the computer at a resolution supported by the VR-3?

RGB signals at a resolution that the VR-3 does not support cannot be input correctly. For supported resolutions, check "Main Specifications."

When you connect the computer, did you connect to the [PC IN] connector, not to [THRU] connector?

The [THRU] connector is for passing output through.

Video from the computer is corrupted.

When a rapidly moving video is input from a computer, flicker or other picture corruption may occur. This is called "tearing," and does not indicate an equipment malfunction.

Compositing a logo is not possible.

Is the extraction color set correctly? Alternatively, was the [KEY LEVEL] dial turned in the wrong direction?

By default, black is extracted for luminance keying. If the background is a different color, then correct extraction is not possible. Correct extraction is also impossible when the [KEY LEVEL] dial has been turned in the wrong direction.

No reverb is applied when the dial is turned.

Is [REVERB SW] at the AUDIO menu set to [OFF]?

When this is set to OFF, no reverb is applied when the dial is turned. Also, when the reverb send amount on the input channel is too low, it can be difficult to discern the reverb.

Dimensions

Unit : mm

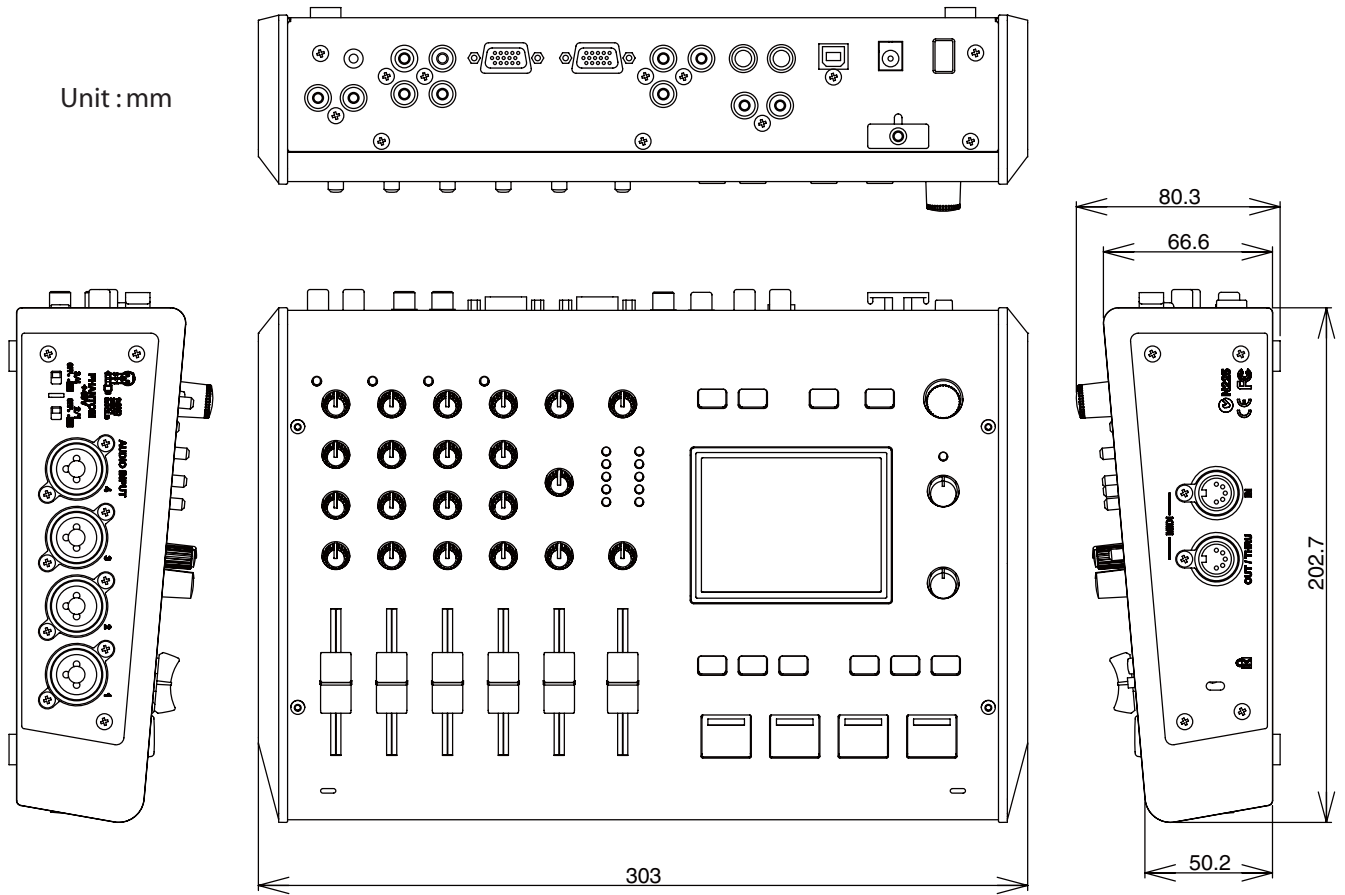

A

Ambient Sound	26
amplifier	21
Audio Mixer	10, 19
AUTO OFF	9

C

CH SCAN	24
CHR KEY	13
Chroma key	36
COMPOSITION	13, 29
cord hook	8

E

EQ	11
----------	----

F

fade	24
Faders	11
FREEZE	12, 24

G

GAIN	11, 25
------------	--------

H

headphones	15
------------------	----

I

inset screen	31
Internal mic	10

K

KEY	13, 34, 36
KEY LEVEL	13

L

Level Meter	11
LUMI KEY	13
Luminance key	34

M

MASTER	11
MENU	12
Microphones	19
MONITOR	12

N

NTSC	43
------------	----

O

Operating Systems	38
OUTPUT FADE	12
overlay	41

P

PAL	43
PAN	11, 26
PHANTOM	15
PHONES	11, 15
Picture-in-Picture	29
PinP	13, 29
PREVIEW	21
projectors	21

R

REVERB	28
reverb	11

S

scan converter	20
Sensitivity	25
sources	18
speakers	21
SPLIT	13
split	32

T

Touch Panel	22
TRANSITION	12
transition effect	22

U

USB Port	14
USB port	38

V

VALUE	12
VIDEO SELECT	12, 23
Video Select	10
view mode	12

Volume Balance	27
----------------------	----



For EU Countries

This product complies with the requirements of EMC Directive 2004/108/EC.

For the USA

FEDERAL COMMUNICATIONS COMMISSION RADIO FREQUENCY INTERFERENCE STATEMENT

This equipment has been tested and found to comply with the limits for a Class B digital device, pursuant to Part 15 of the FCC Rules. These limits are designed to provide reasonable protection against harmful interference in a residential installation. This equipment generates, uses, and can radiate radio frequency energy and, if not installed and used in accordance with the instructions, may cause harmful interference to radio communications. However, there is no guarantee that interference will not occur in a particular installation. If this equipment does cause harmful interference to radio or television reception, which can be determined by turning the equipment off and on, the user is encouraged to try to correct the interference by one or more of the following measures:

- Reorient or relocate the receiving antenna.
- Increase the separation between the equipment and receiver.
- Connect the equipment into an outlet on a circuit different from that to which the receiver is connected.
- Consult the dealer or an experienced radio/TV technician for help.

This device complies with Part 15 of the FCC Rules. Operation is subject to the following two conditions:

- (1) this device may not cause harmful interference, and
- (2) this device must accept any interference received, including interference that may cause undesired operation.

This equipment requires shielded interface cables in order to meet FCC class B limit.

Any unauthorized changes or modifications not expressly approved by the party responsible for compliance could void the user's authority to operate the equipment.

For Canada

NOTICE

This Class B digital apparatus meets all requirements of the Canadian Interference-Causing Equipment Regulations.

AVIS

Cet appareil numérique de la classe B respecte toutes les exigences du Règlement sur le matériel brouilleur du Canada.

For C.A. US (Proposition 65)

WARNING

This product contains chemicals known to cause cancer, birth defects and other reproductive harm, including lead.

For EU Countries



UK This symbol indicates that in EU countries, this product must be collected separately from household waste, as defined in each region. Products bearing this symbol must not be discarded together with household waste.

DE Dieses Symbol bedeutet, dass dieses Produkt in EU-Ländern getrennt vom Hausmüll gesammelt werden muss gemäß den regionalen Bestimmungen. Mit diesem Symbol gekennzeichnete Produkte dürfen nicht zusammen mit dem Hausmüll entsorgt werden.

FR Ce symbole indique que dans les pays de l'Union européenne, ce produit doit être collecté séparément des ordures ménagères selon les directives en vigueur dans chacun de ces pays. Les produits portant ce symbole ne doivent pas être mis au rebut avec les ordures ménagères.

IT Questo simbolo indica che nei paesi della Comunità europea questo prodotto deve essere smaltito separatamente dai normali rifiuti domestici, secondo la legislazione in vigore in ciascun paese. I prodotti che riportano questo simbolo non devono essere smaltiti insieme ai rifiuti domestici. Ai sensi dell'art. 13 del D.Lgs. 25 luglio 2005 n. 151.

ES Este símbolo indica que en los países de la Unión Europea este producto debe recogerse aparte de los residuos domésticos, tal como está regulado en cada zona. Los productos con este símbolo no se deben depositar con los residuos domésticos.

PT Este símbolo indica que nos países da UE, a recolha deste produto deverá ser feita separadamente do lixo doméstico, de acordo com os regulamentos de cada região. Os produtos que apresentem este símbolo não deverão ser eliminados juntamente com o lixo doméstico.

NL Dit symbool geeft aan dat in landen van de EU dit product gescheiden van huishoudelijk afval moet worden aangeboden, zoals bepaald per gemeente of regio. Producten die van dit symbool zijn voorzien, mogen niet samen met huishoudelijk afval worden verwijderd.

DK Dette symbol angiver, at i EU-lande skal dette produkt opsamles adskilt fra husholdningsaffald, som defineret i hver enkelt region. Produkter med dette symbol må ikke smides ud sammen med husholdningsaffald.

NO Dette symbolet indikerer at produktet må behandles som spesialavfall i EU-land, iht. til retningslinjer for den enkelte regionen, og ikke kastes sammen med vanlig husholdningsavfall. Produkter som er merket med dette symbolet, må ikke kastes sammen med vanlig husholdningsavfall.

SE Symbolen anger att i EU-länder måste den här produkten kasseras separat från hushållsavfall, i enlighet med varje regions bestämmelser. Produkter med den här symbolen får inte kasseras tillsammans med hushållsavfall.

FI Tämä merkintä ilmaisee, että tuote on EU-maissa kerättävä erillään kotitalousjätteistä kunkin alueen voimassa olevien määräysten mukaisesti. Tällä merkinnällä varustettuja tuotteita ei saa hävittää kotitalousjätteiden mukana.

HU Ez a szimbólum azt jelenti, hogy az Európai Unióban ezt a terméket a háztartási hulladéktól elkülönítve, az adott régióban érvényes szabályozás szerint kell gyűjteni. Az ezzel a szimbóllumal ellátott termékeket nem szabad a háztartási hulladék közé dobni.

PL Symbol oznacza, że zgodnie z regulacjami w odpowiednim regionie, w krajach UE produktu nie należy wyrzucać z odpadami domowymi. Produktów opatrzonych tym symbolem nie można utylizować razem z odpadami domowymi.

CZ Tento symbol udává, že v zemích EU musí být tento výrobek sbírán odděleně od domácího odpadu, jak je určeno pro každý region. Výrobky nesoucí tento symbol se nesmí vyhazovat spolu s domácím odpadem.

SK Tento symbol vyjadruje, že v krajinách EÚ sa musí zber tohto produktu vykonávať oddelene od domového odpadu, podľa nariadení platných v konkrétnej krajine. Produkty s týmto symbolom sa nesmú vyhazovať spolu s domovým odpadom.

EE See sümbol näitab, et EL-i maades tuleb see toode olmeprügist eraldi koguda, nii nagu on igas piirkonnas määratletud. Selle sümboliga märgitud tooteid ei tohi ära visata koos olmeprügiga.

LT Šis simbolis rodo, kad ES šalyse šis produktas turi būti surenkamas atskirai nuo buitinių atliekų, kaip nustatyta kiekviename regione. Šiuo simboliu paženklinoti produktai neturi būti išmetami kartu su buitiniomis atliekomis.

LV Šis simbols norāda, ka ES valstīs šo produktu jāievāc atsevišķi no mājsaimniecības atkritumiem, kā noteikts katrā reģionā. Produktus ar šo simbolu nedrīkst izmest kopā ar mājsaimniecības atkritumiem.

SI Ta simbol označuje, da je treba proizvod v državah EU zbirati ločeno od gospodinjjskih odpadkov, tako kot je določeno v vsaki regiji. Proizvoda tem znakom ni dovoljeno odlagati skupaj z gospodinjjskimi odpadki.

GR Το σύμβολο αυτό υποδηλώνει ότι στις χώρες της Ε.Ε. το συγκεκριμένο προϊόν πρέπει να συλλέγεται χωριστά από τα υπόλοιπα οικιακά απορρίμματα, σύμφωνα με όσα προβλέπονται σε κάθε περιοχή. Τα προϊόντα που φέρουν το συγκεκριμένο σύμβολο δεν πρέπει να απορρίπτονται μαζί με τα οικιακά απορρίμματα.

DECLARATION OF CONFORMITY Compliance Information Statement

Model Name : VR-3
 Type of Equipment : AV MIXER
 Responsible Party : Roland Systems Group U.S.
 Address : 801 West Orchard Drive, Suite 3, Bellingham, WA 98225
 Telephone : (360)594-4282

有关产品中所含有害物质的说明

本资料就本公司产品中所含的特定有害物质及其安全性予以说明。

本资料适用于 2007 年 3 月 1 日以后本公司所制造的产品。

环保使用期限



此标志适用于在中国国内销售的电子信息产品，表示环保使用期限的年数。所谓环保使用期限是指在自制造日起的规定期限内，产品中所含的有害物质不致引起环境污染，不会对人身、财产造成严重的不良影响。环保使用期限仅在遵照产品使用说明书，正确使用产品的条件下才有效。不当的使用，将会导致有害物质泄漏的危险。

产品中有毒有害物质或元素的名称及含量

部件名称	有毒有害物质或元素					
	铅(Pb)	汞(Hg)	镉(Cd)	六价铬(Cr(VI))	多溴联苯(PBB)	多溴二苯醚(PBDE)
外壳(壳体)	×	○	○	○	○	○
电子部件(印刷电路板等)	×	○	×	○	○	○
附件(电源线、交流适配器等)	×	○	○	○	○	○

○：表示该有毒有害物质在该部件所有均质材料中的含量均在 SJ/T11363-2006 标准规定的限量要求以下。
 ×：表示该有毒有害物质至少在该部件的某一均质材料中的含量超出 SJ/T11363-2006 标准规定的限量要求。
 因根据现有的技术水平，还没有什么物质能够代替它。



* 5 1 0 0 0 2 3 6 7 5 - 0 2 *