

SONY

3-756-954-21(1)

UHF Synthesized Transmitter

Model:

WRT-860A

Operating Instructions page 2

Before operating the unit, please read this manual thoroughly and retain it for future reference.

Manual de instrucciones página 17

Antes de utilizar la unidad, lea detenidamente este manual de instrucciones, y consérvelo para futuras referencias.

English

Owner's Record

The model and serial numbers are located at the rear of the unit. Record the serial number in the space provided below. Refer to these numbers whenever you call upon your Sony dealer regarding this product.

Model No. WRT-860A Serial No. _____

Notice for customers in the U.S.A.

Use of Sony wireless devices is regulated by the Federal Communications Commission as described in Part 74 subpart H of the FCC regulations and users authorized thereby are required to obtain an appropriate licence.

You are cautioned that any changes or modifications not expressly approved in this manual could void your authority to operate this equipment.

Notice for customers in Canada:

Use of Sony wireless devices is regulated by the Industry Canada as described in their Radio Standard Specification RSS-211.

A licence is normally required. The local district office of Industry Canada should therefore be contacted. When the operation of the device is within the broadcast band, the licence is issued on no-interference, no-protection basis with respect to broadcast signals.

Avis pour les clients au Canada:

L'usage des appareils sans-fil Sony est réglé par l'Industrie Canada comme décrit dans leur Cahier des Normes Radioélectriques CNR-211. Une licence est normalement requise. Le bureau de l'Industrie Canada doit être contacté. Lorsque l'opération de l'appareil est dans les limites de la bande de radiodiffusion, la licence est émanée sur la base de non-interférence, non-protection avec les signaux de radiodiffusion.

Table of Contents

Precautions	3
Introduction	4
Features	5
Channels and Carrier Frequencies	6
Parts Identification	7
Power Supply	9
Connection	10
Operation	11
Changing the Channel Selection	11
Changing the Input Attenuation Setting	13
Notes on Microphone System Operation	14
Accumulated Time Indication	15
Error Messages	15
Specifications	16

Precautions

- The unit is designed for use in ambient temperature range of 0°C to 50°C (32°F to 122°F).
- Do not place the unit on or near heat sources, such as lighting equipment, power amplifiers, or in a place subject to direct sunlight or excessive moisture. In such places, the external finish or internal parts of the unit may be damaged.
- If the unit is used in a very humid or dusty place or in a place subject to an active gas, clean its surface as well as the connectors with a dry, soft cloth soon after use. Lengthy use of the unit in such places or not cleaning it after its use in such places may shorten its life.
- When cleaning the unit, never use organic solvents such as thinners or benzine, which will damage the finish of the unit.
- The unit has been factory adjusted precisely. Do not tamper with its internal parts or attempt to repair it.

Introduction

The WRT-860A is a transmitter for an 800 MHz band UHF synthesized wireless microphone system to be used for broadcast or movie production purpose.

The other system components include the WRT-810A/830A/867A UHF Synthesized Wireless Microphone, the WRT-820A UHF Synthesized Transmitter, the AN-820A UHF Antenna, the WD-820A UHF Antenna Divider, the WRR-810A UHF Synthesized Tuner, the WRR-820A/840A/860A UHF Synthesized Diversity Tuner.

The microphones/transmitters and tuners are classified by frequency band. See the table to the right.

A 12 MHz frequency band (or two consecutive numbered TV channels) is assigned to each microphone/transmitter and tuner model. To indicate the assigned frequency bands, the parenthesized numbers following the model names in the table show the smaller of the assigned TV channel numbers.

Sony 800 MHz band system models

Frequency band		Model name	
TV channel	Frequency (MHz)	Transmitter or microphone	Tuner
64	770.125 - 775.875	WRT-810A (64)	WRR-810A (64)
65	776.125 - 781.875	WRT-820A (64)	WRR-820A (64) ^{a)} WRR-840A (64) ^{a)}
66	782.125 - 787.875	WRT-810A (66)	WRR-810A (66)
67	788.125 - 793.875	WRT-820A (66)	WRR-820A (66) ^{a)} WRR-840A (66) ^{a)}
68	794.125 - 799.875	WRT-810A (68)	WRR-810A (68)
69	800.125 - 805.875	WRT-820A (68)	WRR-820A (68) ^{a)}
		WRT-830A (68)	WRR-840A (68) ^{a)}
		WRT-860A (68)	WRR-860A (68)
		WRT-867A (68)	

a) For these models, the AN-820A UHF Antenna is required. Use the WD-820A UHF Antenna Divider in addition when required.

Features

Easy selection of 94 channels

With its sophisticated phase locked loop (PLL) circuit, the unit can operate on any one of 94 carrier frequencies selected by a simple button operation.

Compact and lightweight

Innovative, high-density mounting technology has enabled the creation of this compact and lightweight transmitter, which lets you move anywhere for Electronic News Gathering (ENG) and Electronic Field Production (EFP).

Operation powered by widely available batteries

The built-in DC-DC converter allows stable operation, for about 6 hours continuously, with just two LR6 (size AA) alkaline batteries.

CPU and LCD for coordinated operation control

The built-in CPU controls operation of the unit, including the PLL circuit function. The LCD shows the current channel number, the residual battery power, input attenuation setting, AF input level and RF output.

An accumulated operation time indication is also provided for simple control of the time of battery use (in 1-minute increments).

Saved channel and input attenuation settings

The unit stores the channel and the input attenuation settings when it is turned off. The saved settings are retained even if the batteries are removed. Therefore, when using the unit next time, you need not make the same settings again.

Highly reliable electronic attenuator

The built-in input level attenuator is adjustable in a range of 0 to 30 dB in 3-dB steps. It reduces signal distortion when an excessively strong input signal is received.

RF carrier with tone signal

The unit transmits the RF carrier accompanied by a tone signal, enabling the tuner with a tone squelch circuit to take out only the target audio signal received.

Wide dynamic range and low noise

The compander (compressor/expander) system enables transmission over a wide dynamic range with minimum noise.

Channels and Carrier Frequencies

The WRT-860A can transmit on any selected wireless channel among the 68 and 69 TV bands listed below.

For channel selection, see "Changing the Channel Selection" on page 11.

Channel	Frequency (MHz) TV-68 Band	Channel	Frequency (MHz) TV-68 Band	Channel	Frequency (MHz) TV-69 Band	Channel	Frequency (MHz) TV-69 Band
68-01	794.125	68-25	797.125	69-01	800.125	69-25	803.125
68-02	794.250	68-26	797.250	69-02	800.250	69-26	803.250
68-03	794.375	68-27	797.375	69-03	800.375	69-27	803.375
68-04	794.500	68-28	797.500	69-04	800.500	69-28	803.500
68-05	794.625	68-29	797.625	69-05	800.625	69-29	803.625
68-06	794.750	68-30	797.750	69-06	800.750	69-30	803.750
68-07	794.875	68-31	797.875	69-07	800.875	69-31	803.875
68-08	795.000	68-32	798.000	69-08	801.000	69-32	804.000
68-09	795.125	68-33	798.125	69-09	801.125	69-33	804.125
68-10	795.250	68-34	798.250	69-10	801.250	69-34	804.250
68-11	795.375	68-35	798.375	69-11	801.375	69-35	804.375
68-12	795.500	68-36	798.500	69-12	801.500	69-36	804.500
68-13	795.625	68-37	798.625	69-13	801.625	69-37	804.625
68-14	795.750	68-38	798.750	69-14	801.750	69-38	804.750
68-15	795.875	68-39	798.875	69-15	801.875	69-39	804.875
68-16	796.000	68-40	799.000	69-16	802.000	69-40	805.000
68-17	796.125	68-41	799.125	69-17	802.125	69-41	805.125
68-18	796.250	68-42	799.250	69-18	802.250	69-42	805.250
68-19	796.375	68-43	799.375	69-19	802.375	69-43	805.375
68-20	796.500	68-44	799.500	69-20	802.500	69-44	805.500
68-21	796.625	68-45	799.625	69-21	802.625	69-45	805.625
68-22	796.750	68-46	799.750	69-22	802.750	69-46	805.750
68-23	796.875	68-47	799.875	69-23	802.875	69-47	805.875
68-24	797.000			69-24	803.000		

Parts Identification

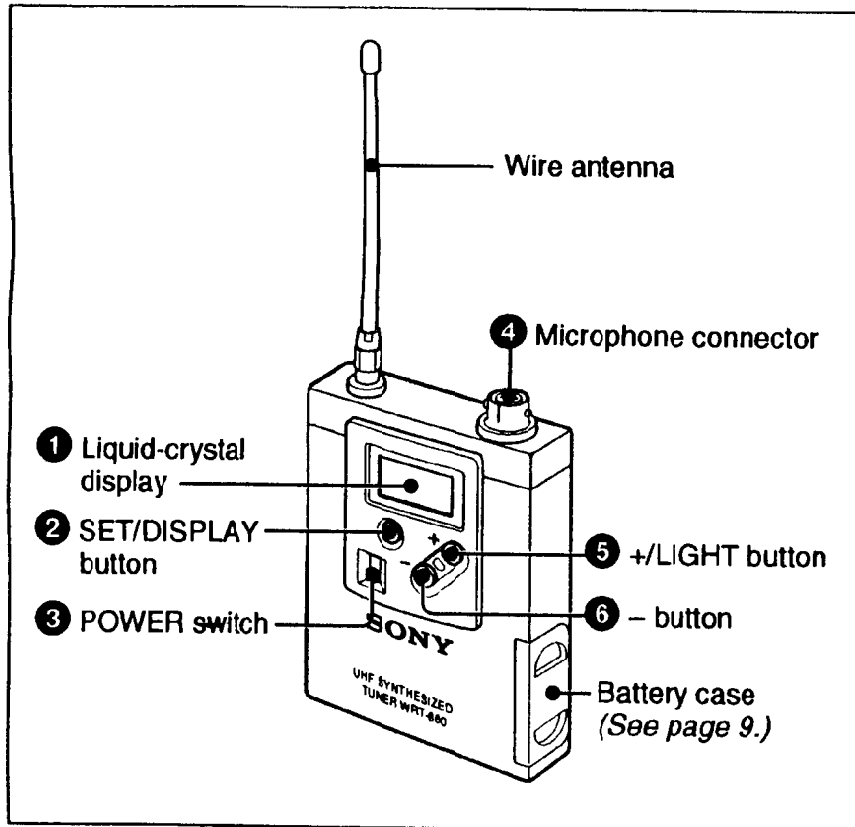

Location of parts

When you mount the transmitter in the supplied soft case, you can easily fix it to your clothing on your belt, etc. with the clip of the case. If it is more convenient to fix the unit with the antenna downwards, mount the transmitter in the case upside-down.

① Liquid-crystal display

The back light lights for 5 seconds when you set the POWER switch to ON.

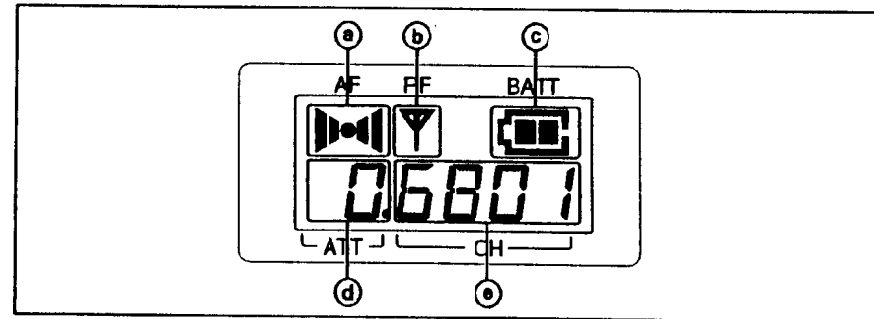

② AF (audio input) indication

Lights when an audio signal over the reference level is being supplied.

③ RF (antenna output) indication

Lights when a signal is being transmitted from the antenna.

④ BATT (battery) indication

Displays the status of the batteries.

See "Battery indication" on page 9.

⑤ ATT (input attenuation) indication

Displays the input attenuation setting in dB, which can be changed in a range of 0 to 30 dB in 3-dB steps.

For the adjustment, see "Changing the Input Attenuation Setting" on page 13.

Parts Identification

① CH (channel) indication

Displays the transmission channel.

Each time you press the SET/DISPLAY button in normal transmit mode, the lower half of the display changes from the attenuator and channel indications to the frequency indication and accumulated time-of-use indication.

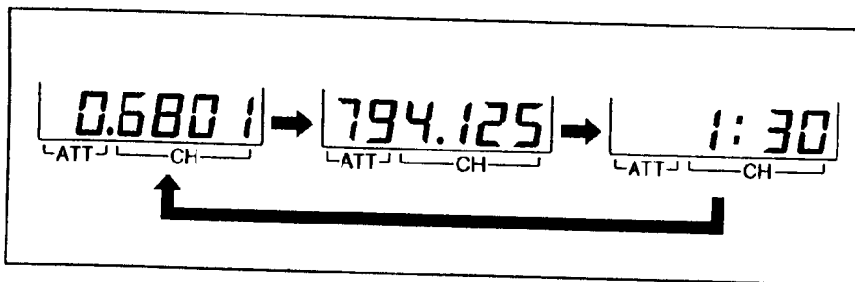

② SET/DISPLAY button

In normal transmit mode, press this button to change the indication items in the lower half of the liquid-crystal display. Press and hold it down for at least 1 second to change the attenuation setting in transmit mode (page 14) or to reset the time of use (page 15).

When you set the POWER switch to ON while holding this button down, setting mode is initiated. In setting mode, press this button to select the item to be set.

For setting mode, see "Operation" on page 11.

③ POWER switch

Turns the power of the transmitter ON or OFF.

When you set this switch to ON without holding any other button, the transmitter is set to normal transmit mode and transmits the signal of the selected channel.

When you set this switch to ON while holding the SET/DISPLAY button down, setting mode is initiated. No signal is transmitted in setting mode.

For setting mode, see "Operation" on page 11.

④ Microphone connector (SMC9-4S)

Connect a microphone.

Pin assignment

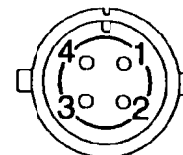

1: +5 V (output)
2: HOT
3: COLD
4: GND

See "Connection" on page 10.

⑤ +/LIGHT button

⑥ - button

In setting mode, press these buttons to select the transmission channel (frequency) and attenuator level.

In normal transmit mode, press the +/LIGHT button to turn on the back light of the liquid-crystal display for approximately 5 seconds. To turn off the back light within 5 seconds, press the +/LIGHT button again.

For setting mode, see "Operation" on page 11.

Power Supply

The transmitter can operate on two LR6 (size AA) alkaline batteries continuously for about 6 hours at 25°C (77°F).

Inserting the batteries

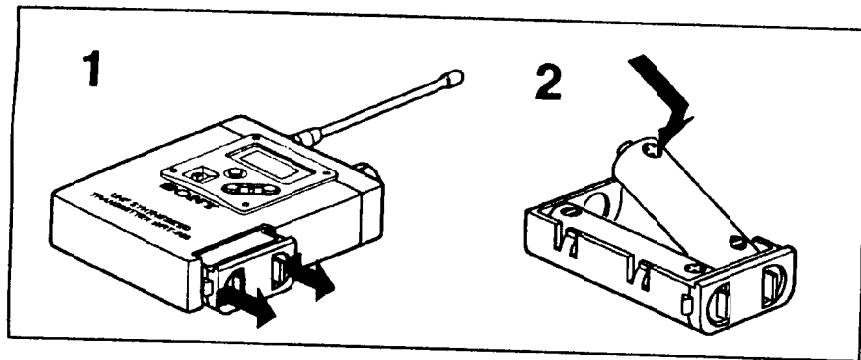

1 Remove the battery case.

2 Match the polarities and insert the batteries.

You can quickly replace the batteries in the future by inserting the same type of batteries in an extra battery case.

3 Reinsert the battery case into the transmitter and press it to securely lock it into place.

Note

If you remove the batteries with the POWER switch set to ON and then reinsert the batteries, "Error 1" may appear on the display. See the Error Message table on page 15 and cancel this condition.

Battery indication

When you turn the power on, the battery status appears in the BATT indication on the liquid-crystal display.

	1	2	3	4
BATT indication	Lights 	Lights 	Flashes 	Goes off
Battery condition	Good	Less than half-charge	Almost exhausted	Completely exhausted

Promptly replace both batteries after reaching stage 3 shown in the table.

The indication may be incorrect if the batteries are not new when inserted. If you plan to use the transmitter for a long period, it is best to replace the batteries with new ones.

Notes on batteries

- Use new alkaline batteries of the same type, and check the recommended "use-by" date on the bottom of the batteries.
- Be careful to insert the batteries with the correct polarity.
- When not using the transmitter for a long period, remove the batteries to avoid leakage. If a battery does leak, clean all leakage from the unit and insert new batteries. Leakage left in the unit may cause poor battery contact. If there seems to be poor battery contact, consult your Sony dealer.

Connection

To use a microphone with an SMC9-4S connector

When using one of the following optional Sony Electret Condenser Microphones equipped with an SMC9-4S connector, connect it as illustrated below.

Sony Electret Condenser Microphones

ECM-44BC

ECM-55BC

ECM-66BC

ECM-77SC/BC/FC

ECM-166BC

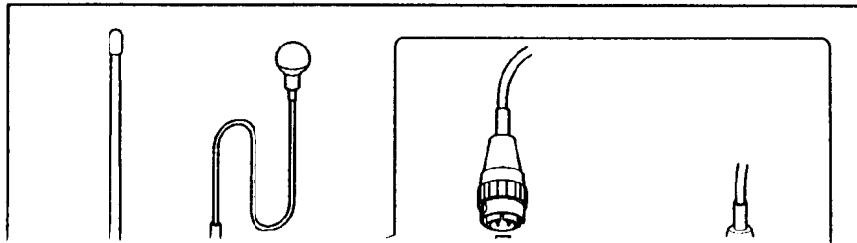

To use a microphone with an XLR-type connector

Using the supplied microphone cable, you can use an optional microphone equipped with an XLR-3-12C connector. Connect the cable and microphone as illustrated below.

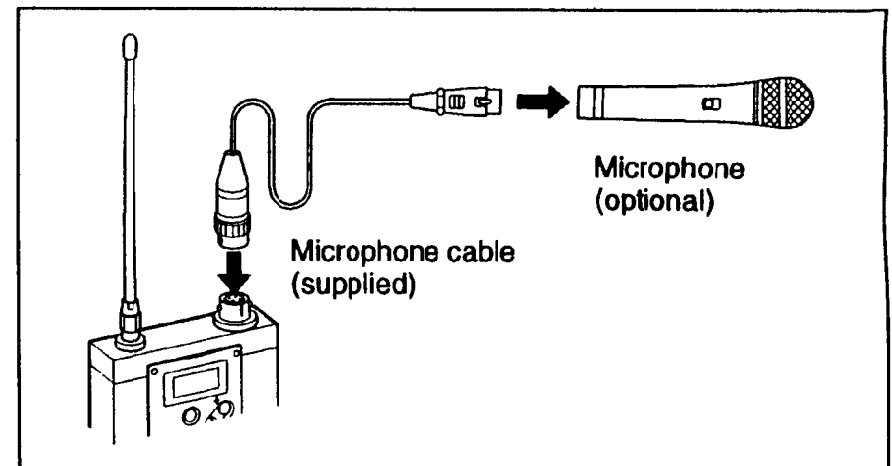

Operation

Changing the Channel Selection

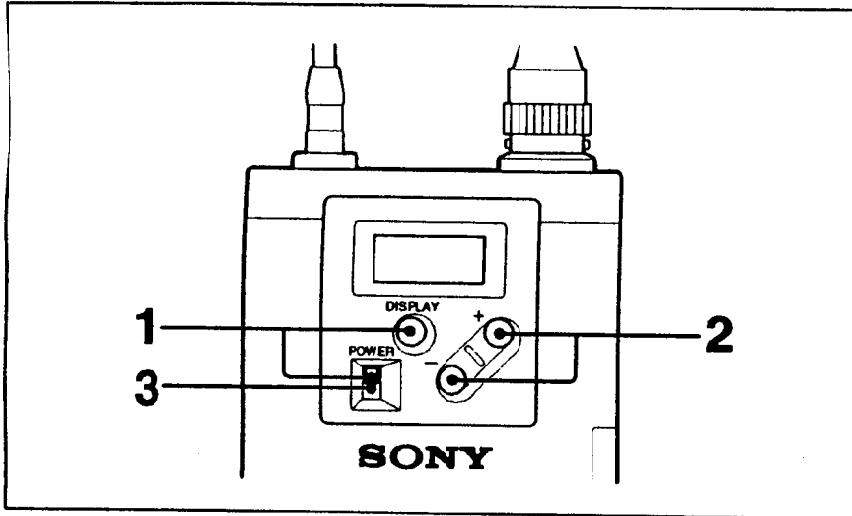

- 1 While holding down the SET/DISPLAY button, set the POWER switch to ON.
Hold the SET/DISPLAY button down until a display appears.
The transmitter goes to setting mode and the indication on the liquid-crystal display flashes.

If the channel or time-of-use indication had been selected before the transmitter was previously turned OFF, the channel indication flashes (channel number selection mode). If the frequency had been selected, the frequency indication flashes (frequency selection mode).

You can change the channel selection either by channel number or frequency. Each time you press the SET/DISPLAY button, channel number selection mode, attenuator adjustment mode (page 13) and frequency selection mode are cyclically switched.

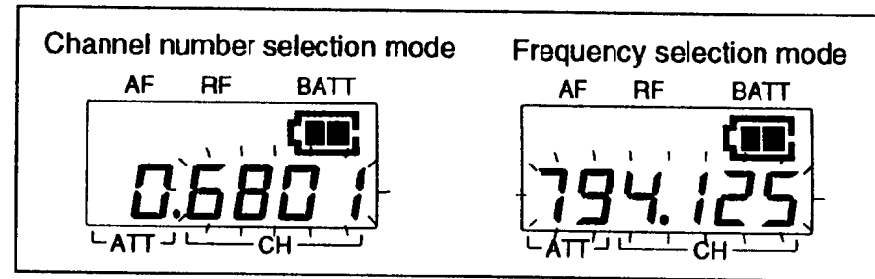

- 2 Press the + or - button to select the channel.
Pressing the + button cyclically changes the channel in the listed order in the table of "Channels and Carrier Frequencies" on page 6. Pressing the - button changes it in the reverse order.

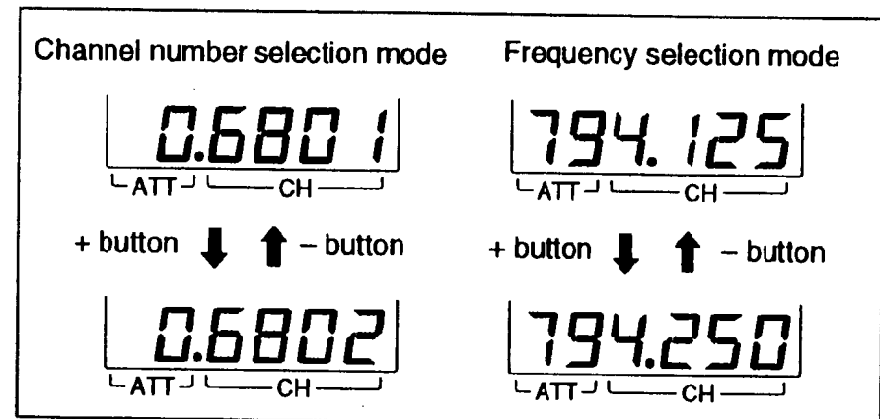

Operation

If you keep either button pressed, the channel setting will be incremented or decremented successively. The setting will cycle the channel from 68-01 through 69-47.

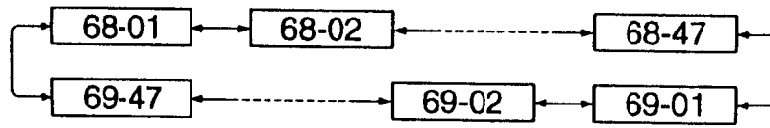

- 3 Once the desired channel number (or frequency) appears, set the POWER switch to OFF to release setting mode. The next time you turn on the power only by setting the POWER switch to ON, the transmitter will be set to transmit mode with the selected channel.

Storing the channel specified

If you remove the batteries before setting the POWER switch to OFF after step 2 on the previous page, the channel specified in step 2 is not stored in memory. The next time you turn on the power, the channel previously set will be resumed.

Notes

- The unit cannot transmit in setting mode.
- Make sure that the channel selected is the same as that selected on the tuner used in the same system.
- Depending on the noise or interference conditions, the selectable channels may not necessarily all be usable. If necessary, you can determine the usable channels by stepping the channel selection through a number of channels on a tuner with the transmitter set to OFF. Those channels on which the RF indicator of the tuner does not light are usable.
- If there is a TV broadcasting station near by, do not use the station's channel.
- The unit may not operate correctly if it is turned on again immediately after turning off the power while in setting mode. Pause for a few seconds or more before turning on the power again.

Changing the Input Attenuation Setting

You can change the input attenuation setting in 3-dB steps in a range of 0 to 30 dB. You can change it either in setting mode or in transmit mode.

Changing in setting mode

- 1 Press the SET/DISPLAY button once in channel number selection mode or twice in frequency selection mode before step 3 on the previous page. Attenuator selection mode is initiated and the ATT indication flashes.

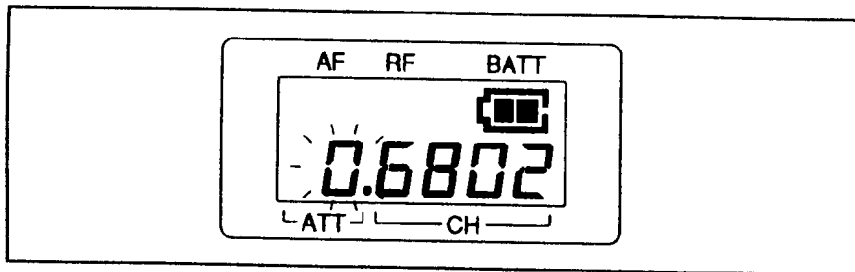

- 2 Press the + or - button to select the attenuation setting.

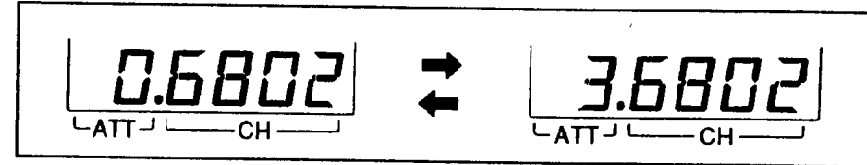

If you keep either button pressed, the setting will be incremented or decremented successively.

- 3 Once the desired level appears, set the POWER switch to OFF to release setting mode. The next time you turn on the power only by setting the POWER switch to ON, the transmitter will be set to transmit mode with the attenuation setting specified in step 2.

Operation

Changing in transmit mode

You can also change the input attenuation setting during transmission.

- 1** When the attenuation setting is indicated on the display, press and hold the SET/DISPLAY button for more than 1 second.
The ATT indication flashes.
- 2** Press the + or – button to select the attenuation setting in the same manner as in setting mode.
- 3** Press the SET/DISPLAY button.
The ATT indication stops flashing.
(Or leave the unit without pressing any button for more than 5 seconds. The flashing automatically stops and normal transmit mode is resumed.)

Notes on Microphone System Operation

- In a system using 11 or fewer transmitters, maintain a distance of at least 30 cm (1 ft.) between each pair of transmitters, and a distance of at least 3 m (10 ft.) between the transmitters and the antenna of a tuner being used in combination. If using the transmitter with the WRT-810A(66)/810A(64)/820A(66)/820A(64) units in a system with 12 to 19 channels, maintain a distance of at least 6 m (20 ft.) between the transmitter and the antenna of a tuner being used in combination.
For details of operation with 2 or more channels, refer to the Operating Instructions for the WRR-810A UHF Synthesized Tuner and WRR-820A/840A/860A UHF Synthesized Diversity Tuners.
- Ensure that the tuners set to channels not being used are either turned off or set to the minimum output level.
- When powering the transmitter on or off, to keep the noise to a minimum, set the audio output level from the tuner or mixer to a minimum.
- Powering the transmitter on without checking the channel selection first may interfere with the operation of other microphones/transmitters, if the current setting is already being used.

Accumulated Time Indication

The time indication accumulates time in hours and minutes when the WRT-860A is on. Press the SET/DISPLAY button to switch the channel indication to the time-of-use indication.

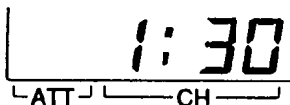

To reset the time indication

Reset the indication to "0:00" whenever you replace the batteries so that it can display the running time of the batteries.

- 1 Set the POWER switch to ON (transmit mode).
- 2 Press the SET/DISPLAY button and go to the time-of-use indication.
- 3 Press and hold the SET/DISPLAY button down for at least 1 second until the indicator starts flashing.
- 4 Press the – button.

The time indication resets to "0:00."

Error Messages

When a problem occurs, one of the following error messages may appear on the display.

Messages	Contents	Measures
Error 1	An error occurred in backup memory data.	The data was initialized. Set the transmitting channel and the input attenuation again.
Error 2	The PLL synthesized circuit is in trouble.	Contact your Sony dealer.
Error 3	The battery voltage exceeds the allowable value.	Use the specified batteries.

Specifications

Transmitter and modulator section

Oscillator	Crystal controlled PLL synthesizer
Carrier frequencies	794.125 to 805.875 MHz (94 settings at 125 kHz intervals)
Tone signal	32.768 kHz
Type of emission	110KF3E
RF power output	20 mW
Frequency stability	Within $\pm 0.005\%$
Spurious radiation	Less than 2.5 μ W
Type of antenna	1/4-wavelength wire
Pre-emphasis	50 μ s
Reference deviation	± 5 kHz
Frequency response	50 to 15,000 Hz
Signal-to-noise ratio	60 dB or more (A-weighted, with reference deviation at WRR-810A/820A/840A/860A)
Audio attenuator	0 to 30 dB, variable in 3-dB steps

Power section

Power requirements	3 V DC (two LR6/size AA alkaline batteries)
Battery life	Approx. 6 hours at 25°C or 77°F with Sony LR6 alkaline batteries
Current consumption	185 mA or less (at 3 V DC)

General

Operating temperature	0°C to +50°C (32°F to 122°F)
Storage temperature	-30°C to +60°C (-22°F to +140°F)
Dimensions	63 × 78 × 17 mm (w/h/d) (2 ¹ / ₂ × 3 ¹ / ₈ × 1 ¹ / ₁₆ inches)
Mass	Approx. 160 g (5.6 oz) including batteries

Supplied accessories

Battery case (1)
Soft case (1)
Microphone cable (1)
Operating Instructions (1)

Design and specifications are subject to change without notice.