

Panasonic

Network camera Operating Instructions

Model Nos. WV-NP240
WV-NP244

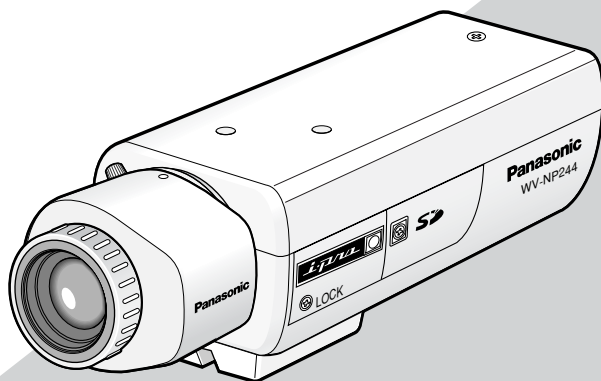

(Lens is option.)

The illustration above is of the WV-NP244.

Before attempting to connect or operate this product,
please read these instructions carefully and save this manual for future use.

The model numbers in these Operating Instructions are given without suffix.

We declare under our sole responsibility that the product to which this declaration relates is in conformity with the standards or other normative documents following the provisions of Directives EEC/73/23 and EEC/89/336.

Wir erklären in alleiniger Verantwortung, daß das Produkt, auf das sich diese Erklärung bezieht, mit der folgenden Normen oder normativen Dokumenten übereinstimmt. Gemäß den Bestimmungen der Richtlinie 73/23/EEC und 89/336/EEC.

Nous déclarons sous notre seule responsabilité que le produit auquel se réfère la présente déclaration est conforme aux normes ou autres documents normalisés conformément aux dispositions des directives EEC/73/23 et CEE/89/336.

Nosotros declaramos bajo nuestra única responsabilidad que el producto a que hace referencia esta declaración está conforme con las normas u otros documentos normativos siguiendo las estipulaciones de las directivas CEE/73/23 y CEE/89/336.

Noi dichiariamo sotto nostra esclusiva responsabilità che il prodotto a cui si riferisce la presente dichiarazione risulta conforme ai seguenti standard o altri documenti normativi conformi alle disposizioni delle direttive CEE/73/23 e CEE/89/336.

Wij verklaren als enige aansprakelijke, dat het product waarop deze verklaring betrekking heeft, voldoet aan de volgende normen of andere normatieve documenten, overeenkomstig de bepalingen van Richtlijnen 73/23/EEC en 89/336/EEC.

Vi erklærer os eneansvarlige for, at dette produkt, som denne deklaration omhandler, er i overensstemmelse med standarder eller andre normative dokumenter i følge bestemmelserne i direktivene 73/23/EEC og 89/336/EEC.

Vi deklarerar härmed vårt fulla ansvar för att den produkt till vilken denna deklaration hänvisar är i överensstämmelse med standarddokument, eller andra normativa dokument som framställs i EEC-direktiv nr. 73/23 och 89/336.

Ilmoitamme yksinomaisella vastuullamme, että tuote, jota tämä ilmoitus koskee, noudattaa seuraavia standardeja tai muita ohjeellisia asiakirjoja, jotka noudattavat direktiivien 73/23/EEC ja 89/336/EE. säädöksiä.

Vi erklærer oss alene ansvarlige for at produktet som denne erklæringen gjelder for, er i overensstemmelse med følgende normer eller andre normgivende dokumenter som følger bestemmelsene i direktivene 73/23/EEC og 89/336/EEC.



CAUTION
RISK OF ELECTRIC
SHOCK DO NOT OPEN



**CAUTION: TO REDUCE THE RISK OF ELECTRIC SHOCK,
DO NOT REMOVE COVER (OR BACK).
NO USER-SERVICEABLE PARTS INSIDE. REFER SERVICING
TO QUALIFIED SERVICE PERSONNEL.**



The lightning flash with arrowhead symbol, within an equilateral triangle, is intended to alert the user to the presence of uninsulated "dangerous voltage" within the product's enclosure that may be of sufficient magnitude to constitute a risk of electric shock to persons.



The exclamation point within an equilateral triangle is intended to alert the user to the presence of important operating and maintenance (servicing) instructions in the literature accompanying the appliance.



Power disconnection. Unit with or without ON-OFF switches have power supplied to the unit whenever the power cord is inserted into the power source; however, the unit is operational only when the ON-OFF switch is in the ON position. The power cord is the main power disconnect for all units.

WARNING:

- This apparatus must be earthed.
- To prevent fire or electric shock hazard, do not expose this apparatus to rain or moisture.
- The apparatus should not be exposed to dripping or splashing and that no objects filled with liquids, such as vases, should be placed on the apparatus.
- All work related to the installation of this product should be made by qualified service personnel or system installers.

FOR YOUR SAFETY PLEASE READ THE FOLLOWING TEXT CAREFULLY.

WARNING: This apparatus must be earthed.

IMPORTANT

The wires in this mains lead are coloured in accordance with the following code.

| | |
|-------------------|---------|
| Green-and-yellow: | Earth |
| Blue: | Neutral |
| Brown: | Live |

As the colours of the wire in the mains lead of this appliance may not correspond with the coloured markings identifying the terminals in your plug, proceed as follows.

The wire which is coloured **green-and-yellow** must be connected to the terminal in the plug which is marked with the letter **E** or by the earth symbol \perp or coloured **green** or **green-and-yellow**.

The wire which is coloured **blue** must be connected to the terminal in the plug which is marked with the letter **N** or coloured **black**.

The wire which is coloured **brown** must be connected to the terminal in the plug which is marked with the letter **L** or coloured **red**.

The serial number of this product may be found on the surface of the unit.

You should note the serial number of this unit in the space provided and retain this instruction as a permanent record of your purchase to aid identification in the event of theft.

Model No. _____
Serial No. _____

Important Safety Instructions

- 1) Read these instructions.
- 2) Keep these instructions.
- 3) Heed all warnings.
- 4) Follow all instructions.
- 5) Do not use this apparatus near water.
- 6) Clean only with dry cloth.
- 7) Do not block any ventilation openings. Install in accordance with the manufacturer's instructions.
- 8) Do not install near any heat sources such as radiators, heat registers, stoves, or other apparatus (including amplifiers) that produce heat.
- 9) Do not defeat the safety purpose of the polarized or grounding-type plug. A polarized plug has two blades with one wider than the other. A grounding type plug has two blades and a third grounding prong. The wide blade or the third prong are provided for your safety. If the provided plug does not fit into your outlet, consult an electrician for replacement of the obsolete outlet.
- 10) Protect the power cord from being walked on or pinched particularly at plugs, convenience receptacles, and the point where they exit from the apparatus.
- 11) Only use attachments/accessories specified by the manufacturer.
- 12) Use only with the cart, stand, tripod, bracket, or table specified by the manufacturer, or sold with the apparatus. When a cart is used, use caution when moving the cart/apparatus combination to avoid injury from tip-over.



- 13) Unplug this apparatus during lightning storms or when unused for long periods of time.
- 14) Refer all servicing to qualified service personnel. Servicing is required when the apparatus has been damaged in any way, such as power-supply cord or plug is damaged, liquid has been spilled or objects have fallen into the apparatus, the apparatus has been exposed to rain or moisture, does not operate normally, or has been dropped.

Limitation of Liability

THIS PUBLICATION IS PROVIDED "AS IS" WITHOUT WARRANTY OF ANY KIND, EITHER EXPRESS OR IMPLIED, INCLUDING BUT NOT LIMITED TO, THE IMPLIED WARRANTIES OF MERCHANTABILITY, FITNESS FOR ANY PARTICULAR PURPOSE, OR NON-INFRINGEMENT OF THE THIRD PARTY'S RIGHT.

THIS PUBLICATION COULD INCLUDE TECHNICAL INACCURACIES OR TYPOGRAPHICAL ERRORS. CHANGES ARE ADDED TO THE INFORMATION HEREIN, AT ANY TIME, FOR THE IMPROVEMENTS OF THIS PUBLICATION AND/OR THE CORRESPONDING PRODUCT (S).

Disclaimer of Warranty

IN NO EVENT SHALL MATSUSHITA ELECTRIC INDUSTRIAL CO., LTD. BE LIABLE TO ANY PARTY OR ANY PERSON, EXCEPT FOR REPLACEMENT OR REASONABLE MAINTENANCE OF THE PRODUCT, FOR THE CASES, INCLUDING BUT NOT LIMITED TO BELOW:

- (1) ANY DAMAGE AND LOSS, INCLUDING WITHOUT LIMITATION, DIRECT OR INDIRECT, SPECIAL, CONSEQUENTIAL OR EXEMPLARY, ARISING OUT OF OR RELATING TO THE PRODUCT;
- (2) PERSONAL INJURY OR ANY DAMAGE CAUSED BY INAPPROPRIATE USE OR NEGLIGENT OPERATION OF THE USER;
- (3) UNAUTHORIZED DISASSEMBLE, REPAIR OR MODIFICATION OF THE PRODUCT BY THE USER;

- (4) ANY PROBLEM, CONSEQUENTIAL INCONVENIENCE, OR LOSS OR DAMAGE, ARISING OUT OF THE SYSTEM COMBINED BY THE DEVICES OF THIRD PARTY.
- (5) ANY CLAIM OR ACTION FOR DAMAGES, BROUGHT BY ANY PERSON OR ORGANIZATION BEING A PHOTOGENIC SUBJECT, DUE TO VIOLATION OF PRIVACY WITH THE RESULT OF THAT SURVEILLANCE-CAMERA'S PICTURE, INCLUDING SAVED DATA, FOR SOME REASON, BECOMES PUBLIC OR IS USED FOR THE PURPOSE OTHER THAN SURVEILLANCE
- (6) ANY PROBLEM, CONSEQUENTIAL INCONVENIENCE, ANY LOSS OR DAMAGE, ARISING OUT OF THE IMPROPER DETECTION OR SLIP-UP IN DETECTION BY VMD (Video Motion Detector) FUNCTION OF THE PRODUCT.

Preface

The network camera WV-NP240/WV-NP244 is designed to operate using a PC on a network (10BASE-T/100BASE-TX) to monitor images. By connecting to a network (LAN) or the Internet, images and audio from the camera can be monitored on a PC via a network. *¹

Features

- Video signals captured by the progressive CCD (Charge-Coupled Device) will be converted into JPEG or MPEG-4 streams, and they can be monitored at up to 30 fps (VGA resolution).
- Audio captured by the built-in microphone can be monitored using a PC via a network.
- When connecting with a PoE (Power over Ethernet, IEEE802.3af compliant) device, power will be supplied by simply connecting a LAN cable. This achieves reduction of installation time including wiring work due to this wire-saving capability.
- 1/3 inch progressive CCD solid-state image sensor with VGA resolution (640 x 480 pixels) achieves high-fidelity motion image scanning with high-resolution.
- The motion detection function that detects a motion in a designated surveillance area and issue an alarm signal is featured. *²
- The FTP backup function and recording of each log on an optional SD memory card are available using the featured SD memory card slot. *³

*¹ It is necessary to configure the network settings of the PC and its network environment to monitor images and audio from the camera on the PC. It is also necessary that a web browser is installed on the PC.

*² The motion detection function is not the dedicated function to prevent thefts, fires, etc..We assume no responsibility whatsoever for any damages resulting from the use of the motion detection function.

*³ This camera is applicable with Panasonic's SD memory card (64 MB, 128 MB, 256 MB, 512 MB and 1 GB).

About these Operating Instructions

There are 2 sets of operating instructions for the WV-NP240/WV-NP244 as follows.

- Operating Instructions (book, these operating instructions)
- Operating Instructions (PDF)

These "Operating Instructions" contain descriptions of how to install and connect this camera, and how to perform the required network settings.

Refer to the "Operating Instructions (PDF)" on the provided CD-ROM for descriptions of how to perform the camera settings and how to operate this camera. Adobe® Reader is required to read these operating instructions (PDF).

System Requirements for a PC

| | |
|--------------------|--|
| OS: | Microsoft® Windows® 2000 SP4, Microsoft® Windows® XP Home Edition SP2, Microsoft® Windows® XP Professional Edition SP2 |
| Computer: | IBM PC/AT Compatible |
| CPU: | Pentium® 4 2.4GHz or faster |
| Memory: | 512 MB or more |
| Monitor: | 1024 x 768 pixels or more, 24-bit True color or better |
| Network Interface: | 10/100Mbps Network interface card must be installed |
| Web Browser: | Microsoft® Internet Explorer 6.0 SP2 |
| CD-ROM Drive: | It is necessary to read the operating instructions on the provided CD-ROM. |
| Adobe® Reader®: | It is necessary to read the operating instructions on the provided CD-ROM. |

* Audio will not be heard if a sound card is not installed on a PC. Audio may be interrupted depending on the network environment.

Trademarks and Registered Trademarks

- Microsoft, Windows and Windows XP are registered trademarks of Microsoft Corporation in the U.S. and/or other countries.
- Intel is a registered trademark and Pentium is a trademark of Intel Corporation or its subsidiaries in the United States and other countries (regions).
- Adobe, Adobe logos, and Acrobat are registered trademarks of Adobe Systems Incorporated in the U.S. and/ or other countries.
- Other names of companies and products contained in these operating instructions may be trademarks or registered trademarks of their respective owners.

CONTENTS

| | |
|--|----|
| Important Safety Instructions | 3 |
| Limitation of Liability | 4 |
| Disclaimer of Warranty | 4 |
| Preface | 5 |
| Features | 5 |
| About these Operating Instructions | 6 |
| System Requirements for a PC | 6 |
| Trademarks and Registered Trademarks | 6 |
| Precautions | 8 |
| Major Operating Controls and Their Functions | 10 |
| Lens Mounting | 12 |
| Optional lens | 12 |
| Focus adjustment | 12 |
| How to use a vari-focal lens | 13 |
| How to use a fixed-focal lens | 13 |
| Installations/Connections | 14 |
| [Connection example] | 17 |
| Insert/Remove an SD Memory Card | 18 |
| How to insert an SD memory card | 18 |
| How to remove the SD memory card | 18 |
| Performing the Network Settings | 19 |
| Install the software | 19 |
| Configure the network settings of the camera using the Panasonic IP Setting software | 19 |
| Troubleshooting | 21 |
| Specifications | 22 |
| Standard Accessories | 24 |

Precautions

Refer to all work related to the installation of this product to qualified service personnel or system installer.

Do not attempt to disassemble the product.

There are no serviceable parts inside. Contact the qualified service personnel for maintenance.

Use this appliance for indoor use only.

Do not expose the appliance to direct sunlight for hours and do not install the product near a heater or an air conditioner. Otherwise, it may cause deformation, discoloration and malfunction. Keep the appliance away from water and moisture.

To keep on using with stable performance

- Parts of this product may deteriorate and it may shorten lifetime of this product when using in locations subject to high temperatures and high humidity. Do not expose the product to direct heat such from a heater.
- Use the appliance at temperature within +5 °C - +35 °C (41 °F - 95 °F) and humidity below 90 %. (when using the appliance without turning the power off)

Handle the appliance with care.

Do not strike or shake, as this may damage the appliance. It may cause a malfunction.

About the PC monitor

When displaying the same image on the PC monitor at length, the PC monitor may be damaged. It is recommended to use a screen-saver.

When an error is detected, the camera will restart automatically.

This camera will restart when detecting an error caused by any reason. The camera will be inoperable for around 30 seconds after

the restart just as when the power is turned on.

Cleaning the camera body

Turn the power off when cleaning of the camera. Use a dry cloth to clean the camera. When the dirt is hard to remove, use a mild detergent and wipe gently. Then, wipe with a dry cloth.

Do not use strong abrasive detergent when cleaning the camera body.

Otherwise, it may cause discoloration.

When using a chemical cloth for cleaning, read the caution provided with the chemical cloth product.

Cleaning the lens

Use a lens cleaning paper (used to clean camera lenses or lenses of spectacles). When using solvent, use an alcohol solvent. Do not use a thinner or a glass cleaner.

SD memory card

- When insert an SD memory card into the SD memory card slot, turn the power of the camera off. Otherwise, it may cause malfunction or damage data recorded on the SD memory card.

Refer to page 18 for descriptions of how to insert/remove an SD memory card.

- When using an unformatted SD memory card, format it using this camera. Recorded data on the SD memory card will be deleted when formatted.

If using an unformatted SD memory card or using an SD card formatted with other device, the camera may not work properly or performance deterioration may be caused.

Refer to the Operating Instructions (PDF) for descriptions of how to format an SD memory card.

- It is recommended to use Panasonic's SD memory card.

Otherwise, the camera may not work properly or performance deterioration may be caused.

- Images saved on the SD memory card may lead to personal information leakage. When it is necessary to give the camera to someone, even when for repair, make sure the SD memory card is removed from the camera.
- There are limited times to overwrite on an SD memory card.

It is recommended to replace the SD memory card when having a periodic maintenance of the camera.

Do not aim the camera at strong light sources.

A light source such as a spot light causes a blooming (light bleeding) or a smear (vertical lines).

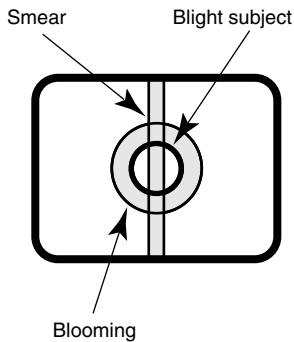

PoE (Power over Ethernet)

Use a PoE hub/device that is compliant with IEEE802.3af standard.

Broadband router

When it is necessary to use a broadband router to connect the camera to the Internet, use a broadband router with the port forwarding function (NAT, IP masquerade).

Refer to the Operating Instructions (PDF) for further information about the port forwarding function.

Radio disturbance

When the camera is used near TV/radio antenna, strong electric field or magnetic field (near a motor or a transformer), images may be distorted and noise sound may be produced.

Do not install the camera in a humid or dust-laden environment.

Otherwise, lifetime of the internal parts may be shortened.

Major Operating Controls and Their Functions

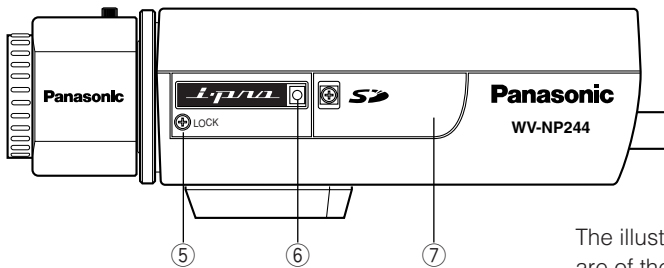
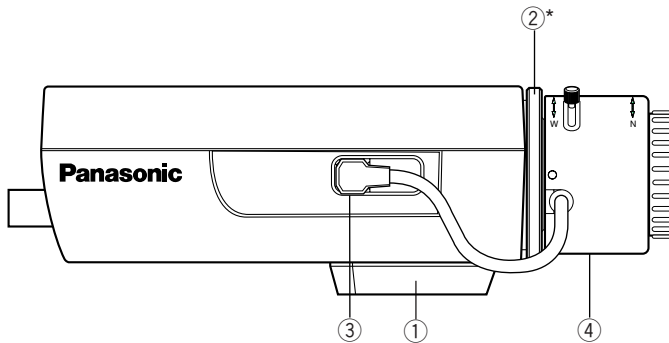

The illustrations above (side views) are of the WV-NP244.

- ① Tripod mount base
- ② Back focus adjusting ring*
- ③ ALC lens connector
- ④ Lens (option)
- ⑤ Focus fixing screw (LOCK)
- ⑥ Microphone
- ⑦ SD card memory slot

* It is necessary to adjust the back focal length together with the lens adjustment. Refer to page 13 for descriptions of how to adjust the back focal length.

<REAR>

WV-NP240

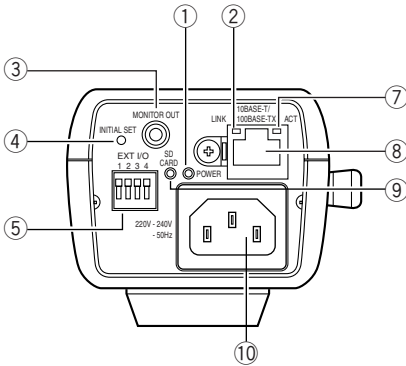

WV-NP244

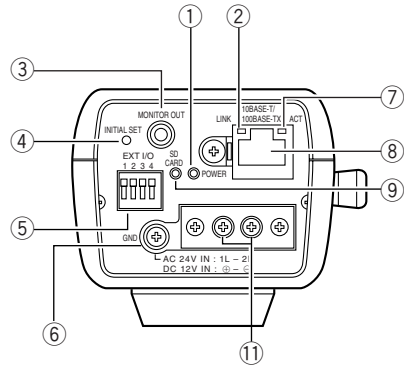

- ① **Power indicator (green)**
- ② **Link indicator**
- ③ **Monitor out connector (ø3.5 mm, mini jack)**
- ④ **INITIAL SET button**
- ⑤ **External I/O terminals**
- ⑥ **Ground terminal**
- ⑦ **Access indicator**
- ⑧ **Network connector**
- ⑨ **SD memory error indicator (red)**
- ⑩ **AC Inlet 220V – 240V 50 Hz (only for the WV-NP240)**
Connect the power cord.
- ⑪ **AC 24 V/DC 12 V (only for the WV-NP244)**
Power cable terminals

- About the [INITIAL SET] button
Turn on the power of the camera while holding down this button, and wait around 5 seconds without releasing this button.
Wait around 30 seconds after releasing the button. The settings including the network settings will be initialized.

Lens Mounting

Mount the lens by rotating it clockwise slowly. Then, connect the lens cable to the ALC lens connector of the camera.

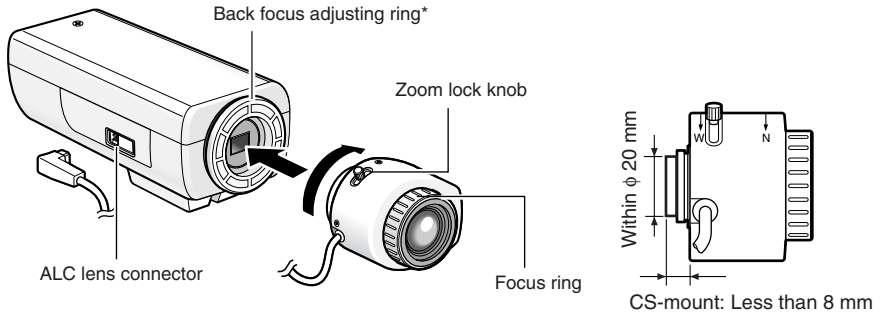

Optional lens

| | Lens type | Model number |
|-----------------------------------|--------------------|---------------------|
| ALC lens for 1/3 inch CCD cameras | Super wide (Fixed) | WV-LA2R8C3B |
| | Wide (Fixed) | WV-LA4R5C3B |
| | Standard (Fixed) | WV-LA9C3B |
| | 2x vari-focal | WV-LZA61/2S |
| | 8x vari-focal | WV-LZ62/8S |

Focus adjustment

When shooting an object using an ALC lens, the first adjusted focus may be out-of-focus depending on the focal depth of the lens in use. In this case, focus on a darker object with the aperture open to prevent out-of-focus.

How to use a vari-focal lens

The following are descriptions of how to use a 2x vari-focal lens. Method of adjustment may be different depending on the lens in use. For further information, refer to the operating instructions of the lens in use.

- ① Loosen the zoom lock knob and slide it to the "T" end.
- ② Rotate the focus ring to one step short of the "F" end.
- ③ Shoot an object which is located 10 m away or more, and adjust the back focal length of the camera.

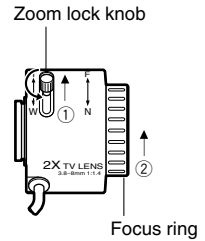

Important:

Make sure that it is possible to focus on an object which is located around 1.2 m away by rotating the focus ring when the zoom lock knob is at the "W" end.

- ④ Slide the zoom lock knob to an appropriate position and tighten it.
- ⑤ Rotate the focus ring to bring the camera into focus.

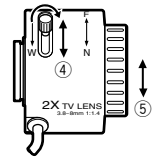

Important:

When changing the angular field of view, adjust focus by changing the zoom lock ring position and rotating the focus ring again.

How to use a fixed-focal lens

When using a fixed-focal lens featuring the focus adjustment, adjust the back focal length after setting the lens focus to the FAR end.

When adjusting the back focal length, loosen the focus fixing screw (LOCK) using a screwdriver first. Tighten the focus fixing screw after the adjustment.

Recommended tightening torque: 0.05 N·m (0.5 kg·cm)

Important:

Do not over tighten the screw. It may strip the thread or cause out-of-focus.

Installations/Connections

Before start the installation/connection, prepare the required devices and cables.
Before starting the connection, turn the power of the devices including the camera and the PC off or disconnect the AC adapters from the outlet.

Step 1

Fix an optional camera mount base onto the desired place and mount the camera on it.
When attaching an optional camera mount base on the bottom of the camera, use the removed screws to attach the camera mount base.
Otherwise, it may cause a drop or malfunction.

<Example>

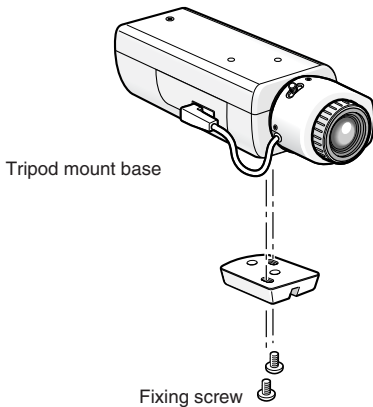

Important:

Method of installation may be different depending on the material of the place where the camera is to be installed.

Step 2

Connect the monaural mini plug ($\varnothing 3.5$ mm) to the monitor out connector on the rear of the camera. (Only when adjusting the angular field of view)

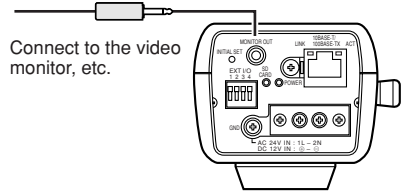

(The illustration above is of the WV-NP244.)

Important:

The monitor out connector is provided only for checking the adjustment the angular field of view on the video monitor when installing the camera or when servicing.

It is not provided for recording/monitoring use.

Step 3

<For the WV-NP240>

Connect the AC power cord (provided as a standard accessory) between the AC inlet of the camera and a 220V - 240V AC 50 Hz outlet.

Notes:

- Connect the power cord firmly.
- The power cord should be long enough for panning and tilting.

If the cable is too short, the power cord plug may be pulled out of the AC inlet socket of camera when the camera pans or tilts.

<For the WV-NP244>

Connect the power cable.

- When using AC 24 V/DC 12 V power supply

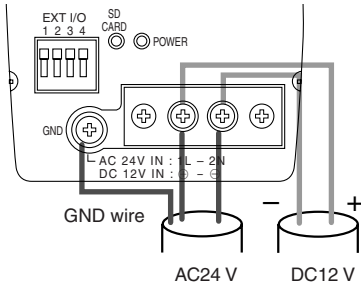

- When using PoE (Power over Ethernet: IEEE802.3af compliant)
Connect a LAN cable (category 5 or better) between a PoE device (such as a PoE hub) and the network connector of the camera.

Important:

- Use all of 4 pairs (8 pins) of the LAN cable.
 - The maximum cable length is 100 m.
 - Make sure that the PoE device in use is compliant with IEEE802.3af standard.
 - When connecting both the AC 24 V/DC 12 V power supply and the PoE device for power supply, PoE will be used for power supply.
 - When disconnecting the LAN cable once, connect the cable again after 2 seconds or more from the disconnection. When the cable is connected before 2 seconds passed, the power may not be supplied from the PoE device.
 - Refer to the provided slip (Recommended network devices for PoE (IEEE802.3af compliant) connection with the WV-NP244) for applicable PoE devices.
-

Step 4

Connect a LAN cable (category 5 or better) to the network connector on the rear of the camera.

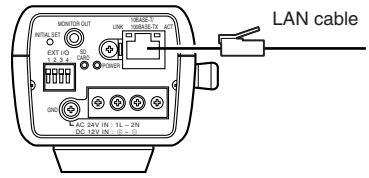

(The illustration above is of the WV-NP244.)

Step 5

Connect an external device to the EXT I/O connector.

When connecting an external device, remove 9 mm – 10 mm of the outer jacket of the cable and twist the cable core to prevent the short circuit first.

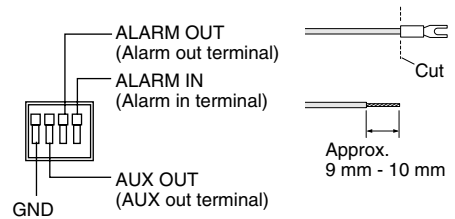

Specification of cable (wire):

AWG #22 - #28
Single core, twisted

Important:

- Do not connect 2 wires or more directly to a terminal. When it is necessary to connect 2 wires or more, use a splitter.
-

<Ratings>

- ALARM IN
 - OFF:** Open
 - ON:** Make contact with GND (0.5 mA or more)
- ALARM OUT
 - OPEN:** Open Collector or DC 4 V – DC 5 V
 - Maximum applied voltage: 20 V
 - CLOSE:** Make contact with GND (100 mA or less)
- AUX OUT
 - OPEN:** Open Collector or DC 4 V – DC 5 V
 - Maximum applied voltage: 20 V
 - CLOSE:** Make contact with GND (100 mA or less)

Important:

Connect an external device with verifying that the ratings are within the specifications above.

[Connection example]

When connecting with a PC directly

(The below example is for the WV-NP244.)

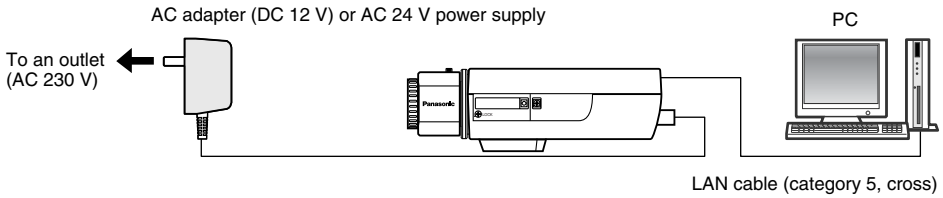

<Required cable>

LAN cable (category 5, cross)

When connecting to a network using a PoE device (hub)

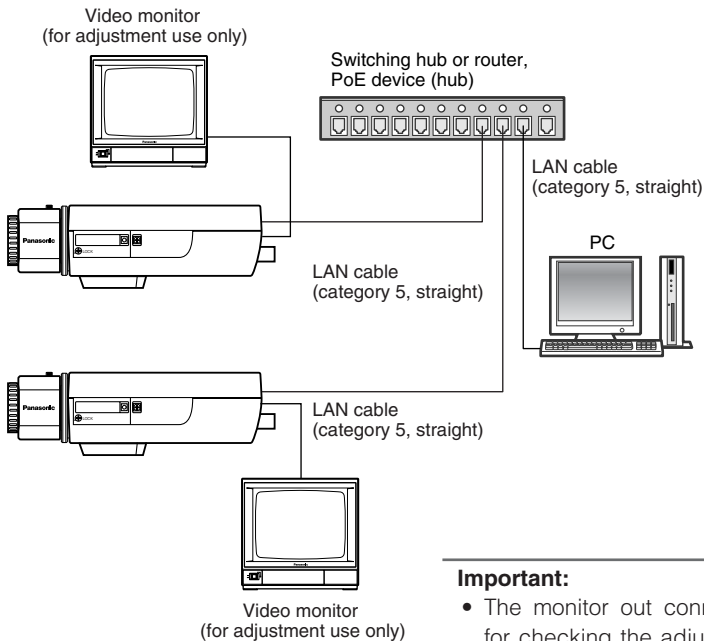

<Required hardware>

Switching hub or router, PoE device (hub)

<Required cable>

LAN cable (category 5, straight)

Important:

- The monitor out connector is provided only for checking the adjustment the angular field of view on the video monitor when installing the camera or when servicing. It is not provided for recording/monitoring use.
 - Use a switching hub or a router which is compliant with 10BASE-T/100BASE-TX.
 - Power supply is required for each network camera. When using a PoE device (hub), AC 24 V/DC 12 V power supply is unnecessary.
-

Insert/Remove an SD Memory Card

How to insert an SD memory card

Important:

- Before inserting an SD memory card, make sure that the power of the camera is turned off.
- Insert an SD memory card backside up.

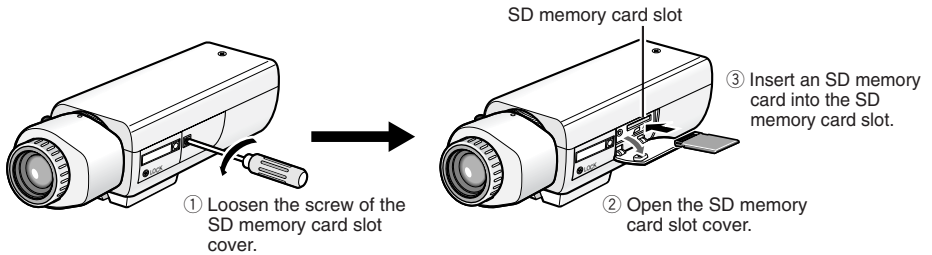

- ④ Close the SD memory card slot cover and fasten the screw.
- ⑤ Select "Use" for "About SD memory card" on the [SD memory card] tab of "Basic Setup" on the setup menu. (☞ Operating Instructions (PDF))

How to remove the SD memory card

Important:

Before removing the SD memory card, select "Not use" for "About SD memory card" on the [SD memory card] tab of "Basic Setup" on the setup menu first. (☞ Operating Instructions (PDF))

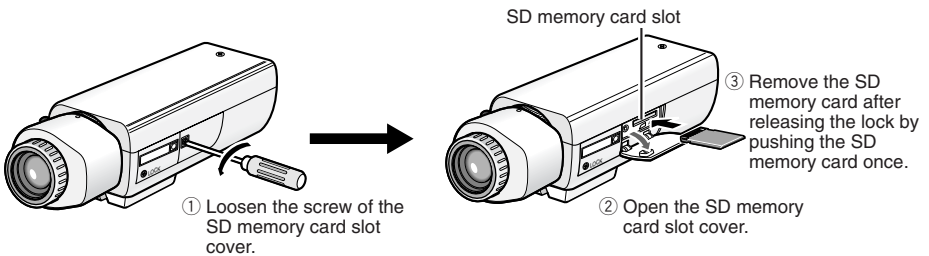

- ④ Close the SD memory card slot cover and fasten the screw.

Performing the Network Settings

Install the software

Before installing the software, read the readme file on the provided CD-ROM first.

Software included on the provided CD-ROM

- Panasonic IP Setting software
Configure the network settings of the camera using this software. Refer to the following for further information.
- Viewer Software "Network Camera View2"
It is necessary to install the viewer software "Network Camera Viewer2" to display images on a PC. Install the viewer software by double-clicking the "Setup.exe" icon on the provided CD-ROM.

Configure the network settings of the camera using the Panasonic IP Setting software

It is possible to perform the network settings of the camera using the IP Setting software on the provided CD-ROM.

When the Panasonic IP Setting software does not work to perform the network settings of the camera, perform the network settings of the camera and the PC individually on the "Network setup" page of the setup menu. Refer to the operating instructions (PDF) for further information.

Important:

- When using Windows XP SP2, the "Windows Security Alert" window may be displayed when start the IP Setting software.
In this case, click the "Unblock" button on the displayed "Windows Security Alert" window.
 - For the security enhancement, the Panasonic IP Setting software will become inoperable when around 20 minutes have passed after turning on the power of the camera.
-

Step 1

Start the Panasonic IP Setting software.

Step 2

Click the [IP Setting] button after selecting the MAC address/IP address of the camera to be configured.

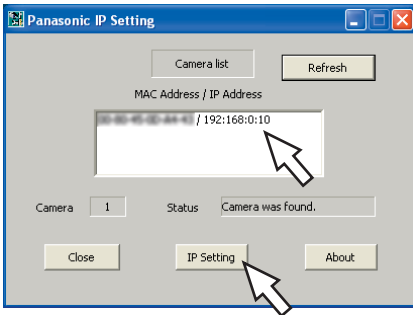

Note:

- When using a DHCP server, the IP address assigned to the camera can be displayed by clicking the [Refresh] button of the IP Setting software.
-

Step 3

Complete each network setup item and click the [Apply] button.

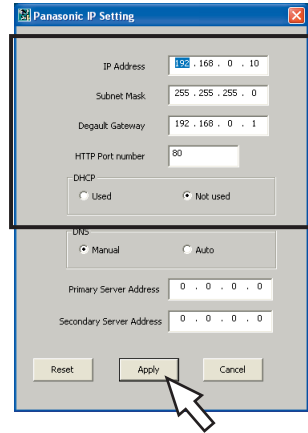

Important:

- It may take for around 30 seconds to complete to upload the settings to the camera after clicking the [Apply] button. The settings may be invalidated when the AC adapter or the LAN cable is disconnected before completing the upload. In this case, perform the settings again.
 - When using a firewall (including software), allow access to all UDP ports.
-

Troubleshooting

Before asking for repairs, check the symptoms with the following table. Contact your dealer if a problem cannot be solved even after checking and trying the solution or if the problem is not described below.

| Symptom | Cause/solution | Reference pages |
|--------------------------------|---|-----------------|
| The power cannot be turned on. | <p>When using AC/DC power supply (WV-NP244)</p> <ul style="list-style-type: none">• Is AC 24 V or DC 12 V power supply connect to the power supply terminal? → Confirm the cable is firmly connected. <p>When using AC 230 V (WV-NP240)</p> <ul style="list-style-type: none">• Is the power cord connected to the AC inlet firmly? → Confirm the power cord is firmly connected to the AC inlet. <p>When using a PoE device for power supply</p> <ul style="list-style-type: none">• Are the PoE device and the network connector on the rear of the camera connected using a LAN cable (4-pair)? → Confirm the cable is firmly connected.• Depending on the PoE device, the power supply will stop when the demanded power exceeds its total power limit for all PoE ports. Refer to the operating instructions of the PoE device in use. | 14 |

Specifications

Other specifications

| | |
|------------------------|---|
| Power source | WV-NP240: AC 230 V 50 Hz WV-NP244: AC 24 V or DC 12 V, PoE (DC 48 V) |
| Power consumption | WV-NP240: 5.0 W (AC 230 V 50 Hz) WV-NP244: 4.8 W (AC 24 V 50 Hz), 400 mA (DC 12 V) |
| PoE: | 4.2 W (Class 2 device) |
| Ambient temperature | -10 °C - +50 °C |
| Ambient humidity | 90 % or less |
| Monitor output | VBS: 1.0 V [P-P]/75 Ω, composite (PAL), ø3.5 mm mini jack (monaural) |
| Network | 10BASE-T/100BASE-TX, RJ45 connector |
| External I/O terminals | ALARM IN x1, ALARM OUT x1, AUX OUT x1 |
| Audio | Captured by the built-in microphone |
| Dimensions | 72 mm (W) x 65 mm (H) x 158 mm (D) (excluding connectors/terminals) |
| Weight | WV-NP240: Approx.470 g WV-NP244: Approx.450 g |

Camera

| | |
|----------------------|------------------------------------|
| Image sensor | 1/3 inch interline transfer CCD |
| Effective pixels | 659 (H) x 494 (V) |
| Scanning area | 5.79 mm (H) x 4.89 mm (V) |
| Scanning system | Progressive |
| Resolution | VGA: 640 x 480, QVGA: 320 x 240 |
| Minimum illumination | 1.5 lx (F1.4) |
| Aperture control | ALC/ELC (BLC ON/OFF) |
| ALC lens drive | DC drive |
| Lens mount | CS-mount |

Network

| | |
|---------------------------|--|
| Resolution | VGA (640 x 480)/QVGA (320 x 240) |
| Image compression method | MPEG-4 Image quality: LOW/NORMAL/FINE Transmission type: UNICAST/MULTICAST JPEG Image quality: 0 SUPER FINE/1 FINE/2/3/4/5 NORMAL/6/7/8/9 LOW (10 steps: 0-9) Transmission type: PULL/PUSH |
| Refresh interval (MPEG-4) | 0.1 fps – 30 fps (Frame rate of JPEG display will be limited when displaying JPEG and MPEG-4 simultaneously.) |
| Bandwidth Control | 64 kbps/128 kbps/256 kbps/512 kbps/1 024 kbps/2 048 kbps/ 4 096 kbps/Unlimited |
| Protocol | TCP/IP, UDP/IP, HTTP, RTP, FTP, SMTP, DHCP, DNS, DDNS, NTP, SNMP |

| | |
|-------------------------------------|---|
| OS | Microsoft® Windows® 2000 Professional SP4, Microsoft® Windows® XP Home Edition SP2, Microsoft® Windows® XP Professional SP2 |
| Web browser | Internet Explorer 6.0 Service Pack2 |
| Maximum concurrent access number | 8 |
| Audio compression method | G.726 (ADPCM) 32 kbps/16 kbps |

Main functions

| | |
|---------------------|--|
| Camera title | Up to 26 characters can be displayed (on a web browser) |
| Electronic Zoom | x1, x1.5, x2, x2.5, x3 |
| Electronic shutter | AUTO |
| AGC | Always ON (fixed) |
| Sensitivity up | OFF, x2AUTO, x4AUTO, x8AUTO, x16AUTO |
| White balance | AUTO/HOLD |
| VMD alarm | ON/OFF, 4 areas available |
| E-mail notification | Notifies up to 4 destination addresses |
| SD memory card | The FTP backup function and recording of each log on an optional SD memory card are available. |
| SD memory card | Manufactured by Panasonic Capacity: 64 MB, 128 MB, 256 MB, 512 MB, 1 GB |
| FTP client | Alarm image transmission, FTP periodic transmission |
| Time adjustment | Manual setting/NTP synchronization |
| Multi-screen | Images from 8 cameras (4 cameras x 2 groups) can be displayed simultaneously. |
| Authentication | User authentication, host authentication, 3 access levels (Administrator/Camera control/Live only) |

Standard Accessories

- CD-ROM* 1 pc.
- Operating Instructions (this book) 1 pc.
- Code Label 1 pc.

The following is for the installation.
Power cord (only for the WV-NP240) 1 pc.

* Panasonic IP Setting software, the viewer software and the operating instructions (PDF) are included on the CD-ROM.

Information on Disposal for Users of Waste Electrical & Electronic Equipment (private households)



This symbol on the products and/or accompanying documents means that used electrical and electronic products should not be mixed with general household waste.

For proper treatment, recovery and recycling, please take these products to designated collection points, where they will be accepted on a free of charge basis. Alternatively, in some countries you may be able to return your products to your local retailer upon the purchase of an equivalent new product.

Disposing of this product correctly will help to save valuable resources and prevent any potential negative effects on human health and the environment which could otherwise arise from inappropriate waste handling. Please contact your local authority for further details of your nearest designated collection point.

Penalties may be applicable for incorrect disposal of this waste, in accordance with national legislation.

For business users in the European Union

If you wish to discard electrical and electronic equipment, please contact your dealer or supplier for further information.

Information on Disposal in other Countries outside the European Union

This symbol is only valid in the European Union.

If you wish to discard this product, please contact your local authorities or dealer and ask for the correct method of disposal.

Matsushita Electric Industrial Co., Ltd.

Osaka, Japan

<http://www.panasonic.co.jp/global/>