



XLH1S

XLH1A

HD Video Camera Recorder

Instruction Manual

Important Usage Instructions

WARNING:



**TO REDUCE THE RISK OF ELECTRIC SHOCK, DO NOT REMOVE COVER (OR BACK). NO USER SERVICEABLE PARTS INSIDE.
REFER SERVICING TO QUALIFIED SERVICE PERSONNEL.**

WARNING:



TO REDUCE THE RISK OF FIRE OR ELECTRIC SHOCK, DO NOT EXPOSE THIS PRODUCT TO RAIN OR MOISTURE.

CAUTION:

TO REDUCE THE RISK OF ELECTRIC SHOCK AND TO REDUCE ANNOYING INTERFERENCE, USE THE RECOMMENDED ACCESSORIES ONLY.

CAUTION:

DISCONNECT THE MAINS PLUG FROM THE SUPPLY SOCKET WHEN NOT IN USE.

For Users in the UK

When replacing the fuse only a correctly rated approved type should be used and be sure to re-fit the fuse cover.

The Mains plug is used as the disconnect device. The Mains plug shall remain readily operable to disconnect the plug in case of an accident.

While using the compact power adapter, do not wrap it or cover it with a piece of cloth, and do not place it in confined narrow spaces. Heat may build up, the plastic case may deform and it could result in electric shock or fire.

CA-920 identification plate is located on the bottom.

•Use of CV-150F/CV-250F DV cable is necessary to comply with the technical requirement of EMC Directive.

European Union (and EEA) only.



This symbol indicates that this product is not to be disposed of with your household waste, according to the WEEE Directive (2002/96/EC) and your national law. This product should be handed over to a designated collection point, e.g., on an authorized one-for-one basis when you buy a new similar product or to an authorized collection site for recycling waste electrical and electronic equipment (EEE). Improper handling of this type of waste could have a possible negative impact on the environment and human health due to potentially hazardous substances that are generally associated with EEE. At the same time, your cooperation in the correct disposal of this product will contribute to the effective usage of natural resources. For more information about where you can drop off your waste equipment for recycling, please contact your local city office, waste authority, approved WEEE scheme or your household waste disposal service. For more information regarding return and recycling of WEEE products, please visit www.canon-europe.com/environment. (EEA: Norway, Iceland and Liechtenstein)

The XL H1S / XL H1A - A Broad Range of Capabilities

Ultimate HD Quality

New and improved lens The HD 20x L IS III is the latest addition to the XL line of high-end interchangeable lenses and now features a built-in iris ring for improved operability.

3CCD system By using three 1/3-in. CCDs (each with a total of 1.67 mega pixels and 1,440x1,080 effective pixels), the camcorder offers a horizontal resolution of 800 TV lines, the highest in HDV standard.

DIGIC DV II image processor The next generation of Canon's video processing engine ensures optimal video quality and color reproduction for high-definition video.

Versatile Artistic Expression

HDV native 1080/25p recording Use the 25F mode for video recordings compliant with native recordings according to HDV specifications (□ 48). Whatever your video needs –TV programs, commercials, music videos or movies– you can shoot it with the XL H1S / XL H1A.

Custom presets Enjoy unparalleled image control to deliver the “look” you want. The camcorder offers 23 customizable parameters you can easily save and exchange as custom preset files (□ 92).

Advanced Professional Features

XLH1S Pro level connectivity An industry-standard HD/SD SDI terminal for uncompressed HD signal output, embedded audio and SMPTE time code (LTC) are just a few of the features of the XL H1S that give it the functionality of professional broadcast cameras.

XLH1S Synchronization Genlock synchronization, as well as TC-IN and TC-OUT terminals, allow the XL H1S to be part of any multi-camera shooting setup.

Enhanced customization Custom functions (□ 100) and custom display (□ 106) options give you even more freedom to control many aspects of the camcorder's operation.

And More

Audio options The camcorder is equipped with two sets of XLR audio input terminals with phantom power supply. Record audio using both audio inputs or combine one audio input and the supplied front microphone. You can also activate the audio peak limiter (□ 55) to avoid distortions during manual audio level adjustment.

Added and improved functionality Push AE (□ 62) • Gain fine-tuning in 0.5 dB increments (□ 66) • Focus limit (□ 46) • Selective NR (□ 73) • Audio output level selection (□ 86) • and more!

About this Manual



Thank you for purchasing the Canon XL H1S / XL H1A. Please read this manual carefully before you use the camcorder and retain it for future reference. Should your camcorder fail to operate correctly, refer to *Troubleshooting* (146).



Conventions Used in this Manual

- ⓘ: Precautions related to the camcorder's operation.
- ⓘ: Additional topics that complement the basic operating procedures.
- 146: Reference page number.
- Capital letters are used to refer to buttons on the camcorder or the wireless controller.
- Brackets [] and capital letters are used to refer to menu options as they are displayed on screen. In tables in the manual, menu options in boldface indicate the default setting.
- The supplied lens, Canon HD Video Lens 20x Zoom XL 5.4-108 mm L IS III, is referred to as the "HD 20x L IS III" lens.
- "Screen" refers to the viewfinder screen.
- "Card" or "Memory card" refers to an SDHC memory card, an SD memory card or a MultiMedia Card (MMC).
- Photographs in the manual are simulated pictures taken with a still camera.
- XL H1S**: Text that applies only to the model shown in the icon.
- Illustrations in the manual show an XL H1S with the HD 20x L IS III lens attached.

Operating modes

The availability of the various functions depends on the operating mode as indicated in the bar.

 ,  : Function can be used in this mode.

 ,  : Function cannot be used in this mode.

Menu item shown at its default position

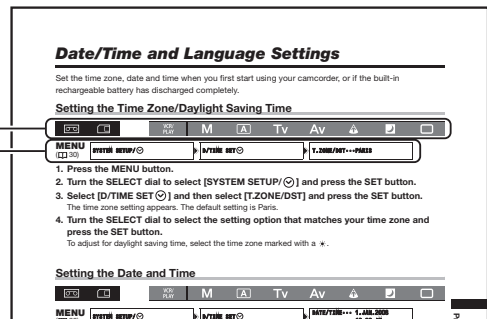

Trademark Acknowledgements

- Canon is a registered trademark of Canon Inc.
- Mini **Dx** is a trademark.
- HDV and the HDV logo are trademarks of Sony Corporation and Victor Company of Japan, Ltd. (JVC).
-  is a trademark.
- Microsoft, Windows and Windows Vista are trademarks or registered trademarks of Microsoft Corporation in the United States and/or other countries.
- Other names and products not mentioned above may be trademarks or registered trademarks of their respective companies.
- ANY USE OF THIS PRODUCT OTHER THAN CONSUMER PERSONAL USE IN ANY MANNER THAT COMPLIES WITH THE MPEG-2 STANDARD FOR ENCODING VIDEO INFORMATION FOR PACKAGED MEDIA IS EXPRESSLY PROHIBITED WITHOUT A LICENSE UNDER APPLICABLE PATENTS IN THE MPEG-2 PATENT PORTFOLIO, WHICH LICENSE IS AVAILABLE FROM MPEG LA, L.L.C., 250 STEELE STREET, SUITE 300, DENVER, COLORADO 80206.

About the HD/HDV and SD/DV Specifications

In the manual, a distinction is made between video signal standards (camera section) and recording standards (recorder section). The video signal can be set to HD (high definition) or SD (standard definition) specifications; the recording standard on the tape will be HDV or DV, respectively.

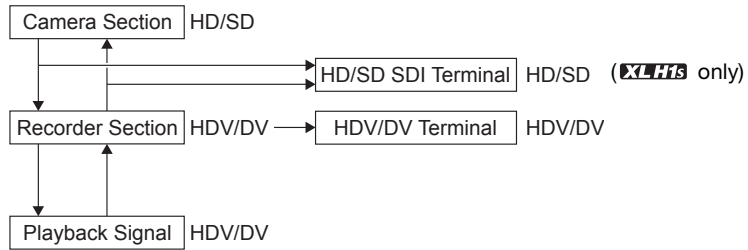

Contents

Introduction

The XL H1S / XL H1A - A Broad Range of Capabilities	3
About this Manual	4
Checking the Supplied Accessories	8
Components Guide	9

Preparations

Preparing the Power Supply	15
Preparing the Camcorder	19
Preparing the Lens	25
Using the Wireless Controller	28
Loading/Removing a Cassette	29
Inserting/Removing a Memory Card	30
Changing Settings with the MENU Button	31
Date/Time and Language Settings	32

Recording

Recording	34
Selecting the Signal Standard and Aspect Ratio	38
Locating the End of the Last Scene	39
Zooming	40
Adjusting the Focus	42
Using the ND Filter	47
Selecting the Frame Rate	48
Setting the Time Code	49
XLH1S Synchronizing the Camcorder's Time Code	50
Setting the User Bit	52
Audio Recording	53
Image Stabilizer	57
Using the Programmed AE Modes	58
Recording in Manual Mode	61
Recording in Shutter-Priority (Tv) Mode	63
Recording in Aperture-Priority (Av) Mode	64
Adjusting the Exposure	65
AE Shift	65
Gain	66
White Balance	67
Zebra Pattern	69
Color Correction	70
Skin Detail Function	72
Selective Noise Reduction	73
Clear Scan	74
Custom Keys	75
Color Bars/Audio Reference Signal	79
Faders	79

External Connections

Video Signal Output Standards	80
Connecting to a Monitor/TV	81
Audio Output	86
Digital Video Control.....	88
Recording an External Video Signal (HDV/DV In, Analog Line-In).....	89
Converting Analog Signals into Digital Signals (Analog-Digital Converter).....	90
Connecting to a Computer.....	91

Customization

Custom Preset Settings	92
Customized Functions	100
Customized On-Screen Displays	106

Playback

Playing Back a Tape.....	110
Returning to a Pre-marked Position.....	112
Index Search	112
Date Search.....	113
Data Code	113
Remote Sensor Mode	114







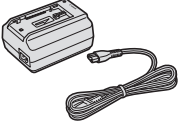
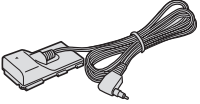
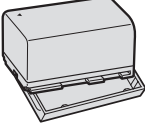
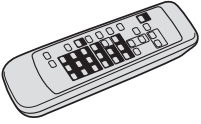

Using a Memory Card

Selecting the Still Image Quality/Size.....	115
File Numbers	116
Recording Still Images on a Memory Card	117
Reviewing a Still Image right after Recording	119
Drive Mode.....	120
Metering Mode	121
Using an Optional Flash	122
Playing Back Still Images from a Memory Card.....	123
Erasing Still images	125
Protecting Still images.....	126
Initializing a Memory Card.....	127
Print Order Settings.....	128

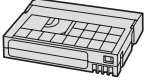
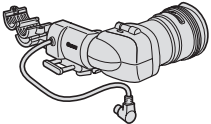
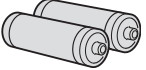
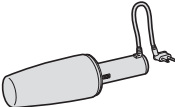
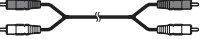
Additional Information

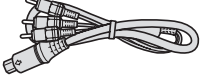
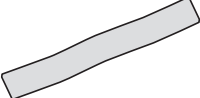
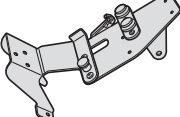
Menu Options and Default Settings	129
Settings Memorized and Retained.....	137
Screen Displays.....	138
List of Messages	140
Maintenance/Others.....	141
Troubleshooting	146
System Diagram	148
Optional Accessories	150
Specifications.....	153
Index.....	156

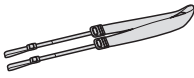
Checking the Supplied Accessories

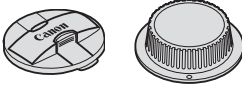
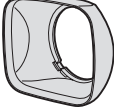
<p>CA-920 Compact Power Adapter</p> 	<p>DC-920 DC Coupler</p> 	<p>BP-950G Battery Pack</p> 	<p>WL-D5000 Wireless Controller</p> 
<p>SDC-32M SD Memory Card</p> 	<p>HDVM-E63PR Digital Videocassette</p> 	<p>Color Viewfinder Unit</p> 	<p>2 x AA (R6) Batteries (for the wireless controller)</p> 
<p>Microphone Unit</p> 	<p>Stereo Cable</p> 	<p>DTC-1000 Component Video Cable</p> 	<p>External Monitor Cable</p> 
<p>Adjustment Band (for the external microphone holder)</p> 	<p>Adapter Holder Unit</p> 	<p>Tripod Adapter Base</p> 	<p>SS-1100 Shoulder Strap</p> 
<p>Camcorder Dust Cap</p> 	<p>Canon HD Video Lens 20x Zoom XL 5.4-108 mm L IS III (incl. soft case)</p> 	<p>Lens Cap and Dust Cap</p> 	<p>Lens Hood</p> 

Components Guide

Left side view

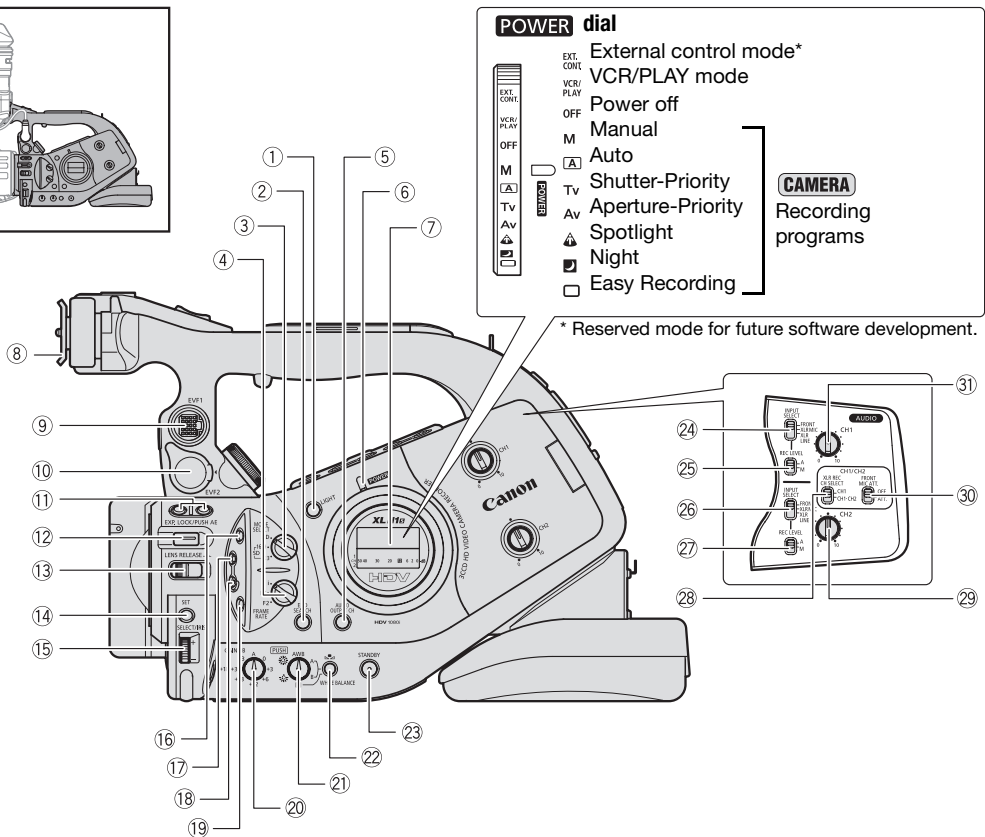
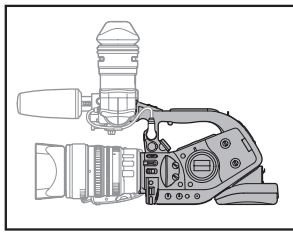

- ① LIGHT button
- ② END SEARCH button (39)
- ③ MODE SELECT switch (38)
- ④ FRAME RATE switch (48)
- ⑤ AUDIO OUTPUT CH button (86)
- ⑥ **POWER** indicator
- ⑦ Side panel (139)
- ⑧ Viewfinder attachment bracket (19)
- ⑨ EVF1 color viewfinder socket (19)
- ⑩ EVF2 external monitor/viewfinder socket (81, 151)
- ⑪ EVF PEAKING/EVF MAGNIFYING buttons (44)
- ⑫ EXP. LOCK button (65)/PUSH AE button (62)
- ⑬ LENS RELEASE switch (25)
- ⑭ SET button (31)
- ⑮ SELECT dial (31)/IRIS dial (61, 64)
- ⑯ (record review) button (37)

- ⑰ BARS/FADE SELECT button (79)
- ⑱ BARS/FADE ON/OFF button (79)
- ⑲ MENU button (31)
- ⑳ GAIN dial (66)
- ㉑ WHITE BALANCE dial (67)
- ㉒ WHITE BALANCE button (67)
- ㉓ STANDBY button (35)
- ㉔ INPUT SELECT switch (CH1) (54)
- ㉕ REC LEVEL switch (CH1) (55)
- ㉖ INPUT SELECT switch (CH2) (54)
- ㉗ REC LEVEL switch (CH2) (55)
- ㉘ XLR REC CH SELECT switch (CH1/CH2) (54)
- ㉙ CH2 dial (55)
- ㉚ FRONT MIC ATT. switch (CH/CH2) (54)
- ㉛ CH1 dial (55)

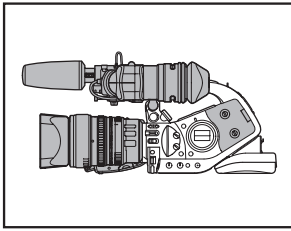

Left side view

Viewfinder unit/Microphone unit

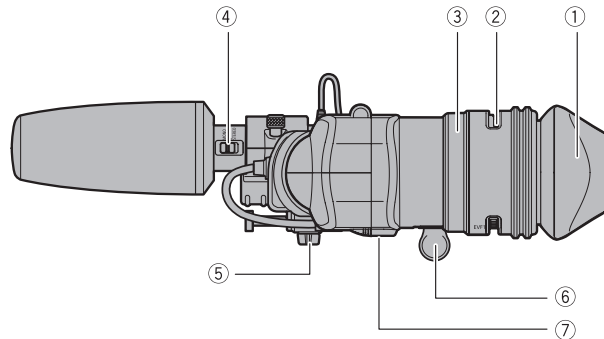

HD 20x L IS III lens

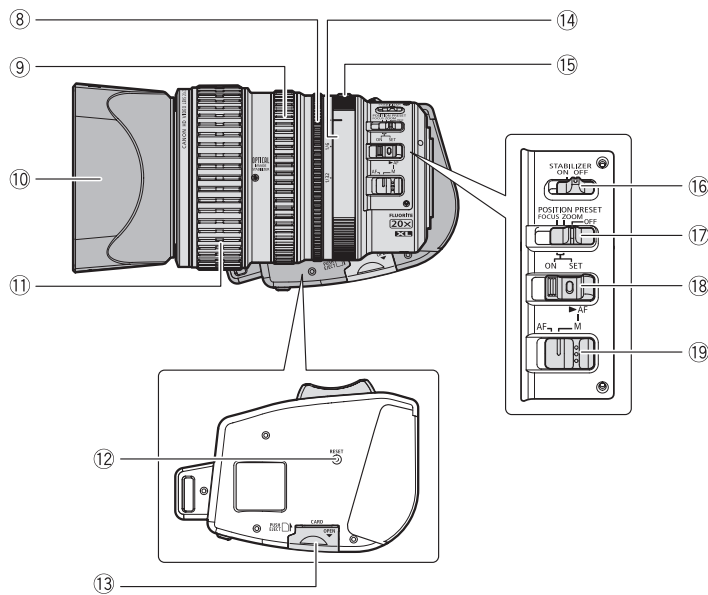

- ① Eye cup (☐ 20)
- ② Dioptic adjustment lever (☐ 21)
- ③ Color viewfinder (☐ 19-22)
- ④ STEREO/MONO microphone selector (☐ 54)
- ⑤ Lock screw (☐ 21)
- ⑥ Viewfinder cable (☐ 19)
- ⑦ Lock release button (☐ 22)
- ⑧ Iris ring (☐ 61, 64)
- ⑨ Zoom ring (☐ 40)
- ⑩ Lens hood (☐ 26)

- ⑪ Focus ring (☐ 42)
- ⑫ RESET button (☐ 146)
- ⑬ Memory card slot (☐ 30)
- ⑭ ND filter operating ring (☐ 47)
- ⑮ ND filter unlock button (☐ 47)
- ⑯ STABILIZER ON/OFF switch (☐ 57)
- ⑰ POSITION PRESET switch (☐ 41)
- ⑱ ► AF switch (☐ 42)/
POSITION PRESET ON/SET switch (☐ 41)
- ⑲ Focus mode switch (☐ 43)

Right side view

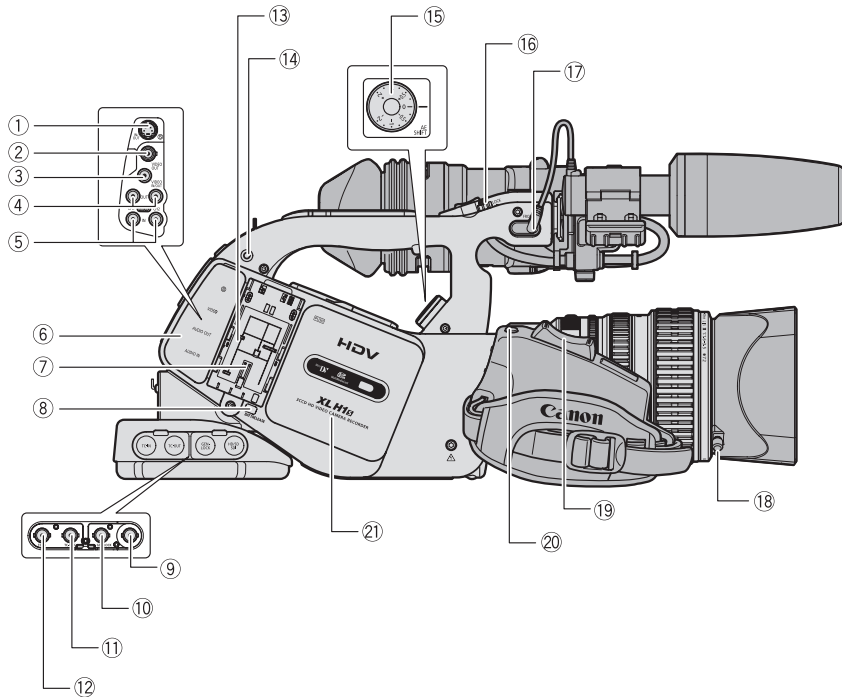

- ① S-video terminal (84)
- ② VIDEO OUT terminal (BNC) (84)
- ③ VIDEO IN/OUT terminal (RCA) (84)
- ④ **AUDIO** OUT terminals (CH1/CH2, RCA) (86)
- ⑤ **AUDIO** IN terminals (CH1/CH2, RCA) (54)
- ⑥ Terminal cover
- ⑦ Battery attachment unit (15)
- ⑧ BATT. RELEASE button (15)
- ⑨ HD/SD SDI terminal* (82)
- ⑩ GENLOCK terminal* (50)
- ⑪ TC-OUT terminal* (50)

- ⑫ TC-IN terminal* (50)
- ⑬ Serial number
- ⑭ Screw hole for adapter holder (24)
- ⑮ AE SHIFT dial (65)
- ⑯ LOCK switch (35)
- ⑰ FRONT MIC terminals (23)
- ⑱ Lens hood lock screw (26)
- ⑲ Grip zoom lever (40)
- ⑳ PHOTO button (117) / MAGN. button (104)
- ㉑ Cassette compartment (29)

* **XL Hi8** only.

Front view

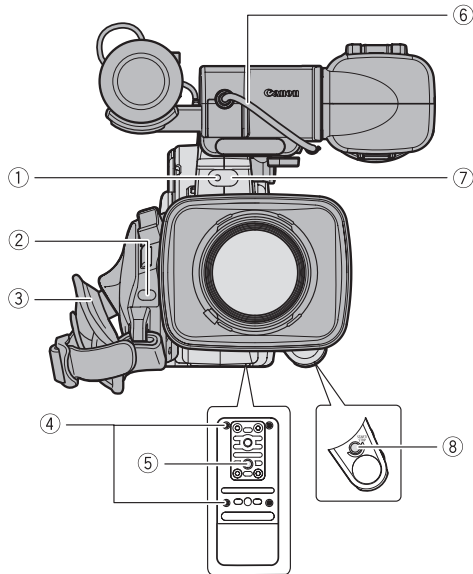

Back view

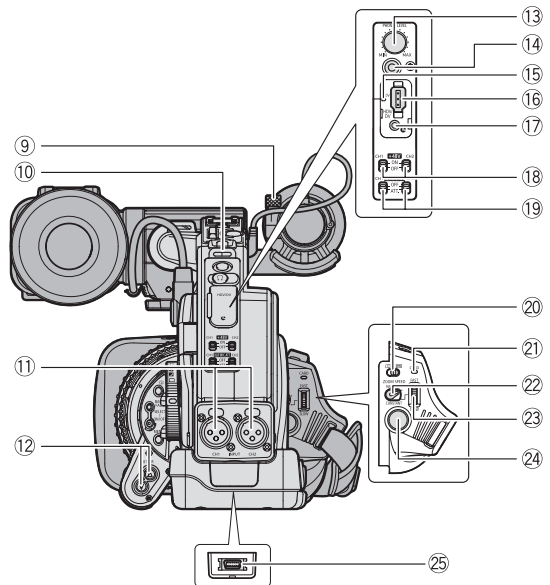

- ① Tally lamp (□ 105)
- ② Remote sensor (□ 28, 114)
- ③ Grip belt (□ 23)
- ④ Attachment sockets for the optional TA-100 Tripod Adapter (□ 151) or the supplied tripod adapter base
- ⑤ Tripod socket
- ⑥ Viewfinder cable (□ 19)
- ⑦ Remote sensor (□ 28, 114)
- ⑧ START/STOP button (□ 34)
- ⑨ Microphone lock screw (□ 23)
- ⑩ Strap mount (□ 23)
- ⑪ INPUT terminals (CH1/CH2, XLR) (□ 54)
- ⑫ SHUTTER ▲▼ buttons (□ 61, 63)

- ⑬ PHONES LEVEL dial
- ⑭ (headphone) terminal
- ⑮ HDV indicator (□ 38)
- ⑯ HDV/DV terminal (□ 83, 89, 91)
- ⑰ terminal
- ⑱ +48V switches (CH1,CH2) (□ 54)
- ⑲ XLR MIC ATT switches (CH1,CH2) (□ 54)
- ⑳ card/tape switch (□ 117)
- ㉑ CARD access indicator (□ 117)
- ㉒ ZOOM SPEED switch (□ 40)
- ㉓ ZOOM SPEED dial (□ 40)
- ㉔ Start/Stop button (□ 34)
- ㉕ COMPONENT OUT terminal (□ 83)

④, ⑤ Using tripods

Do not use tripods with mounting screws longer than 5.5 mm as this may cause damage to the camcorder. To use tripods featuring 3/8" mounting screws, attach first the supplied tripod adapter base and attach the tripod to the adapter base.

⑰ About the terminal

(LANC) stands for Local Application Control Bus System. The terminal allows you to connect and control connected devices. Connect only devices with the mark to the terminal.

○ Operation cannot be guaranteed for connections with devices not bearing the mark.

○ Some buttons of connected devices may not operate or may operate differently than the buttons on the camcorder.

Top view

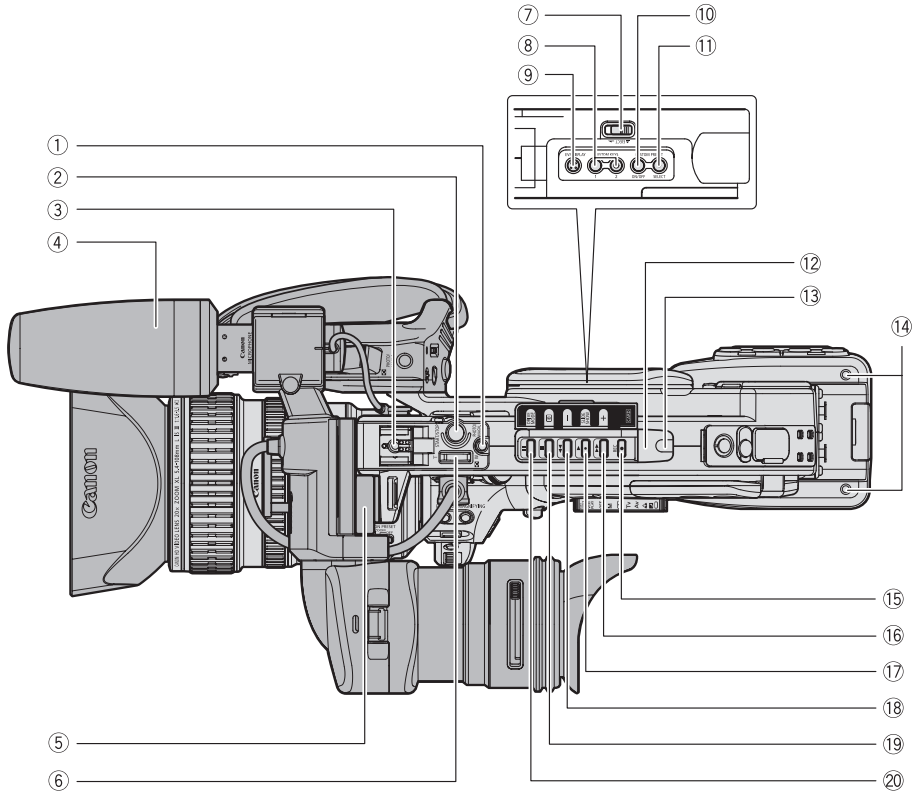

① PHOTO button (☐ 117) / MAGN. button (☐ 104)

② START/STOP button (☐ 34)

③ Hot shoe (☐ 122)

④ Microphone (☐ 23)

⑤ Viewfinder lock screw (☐ 19)

⑥ Handle zoom lever (☐ 40)

⑦ EJECT switch (☐ 29)

⑧ CUSTOM KEYS (☐ 75)

⑨ EVF DISPLAY button (☐ 37)

⑩ CUSTOM PRESET ON/OFF button (☐ 95)

⑪ CUSTOM PRESET SELECT button (☐ 95)

⑫ Remote sensor (☐ 28, 114)

⑬ Tally lamp (☐ 105)

⑭ Screw holes for adapter holder (☐ 24)

⑮ REC ● (record) button (☐ 89)

⑯ ►► (fast forward) button (☐ 110) /
CARD + button (☐ 96, 123)

⑰ ► (play) button (☐ 110) /
SLIDESHOW button (☐ 123)

⑱ ◀◀ (rewind) button (☐ 110) /
CARD - button (☐ 96, 123)

⑲ ■ (stop) button (☐ 110, 113) /

☉ (metering mode) button (☐ 121)

⑳ || (pause) button (☐ 110) /
DRIVE MODE button (☐ 120)

WL-D5000 Wireless Controller

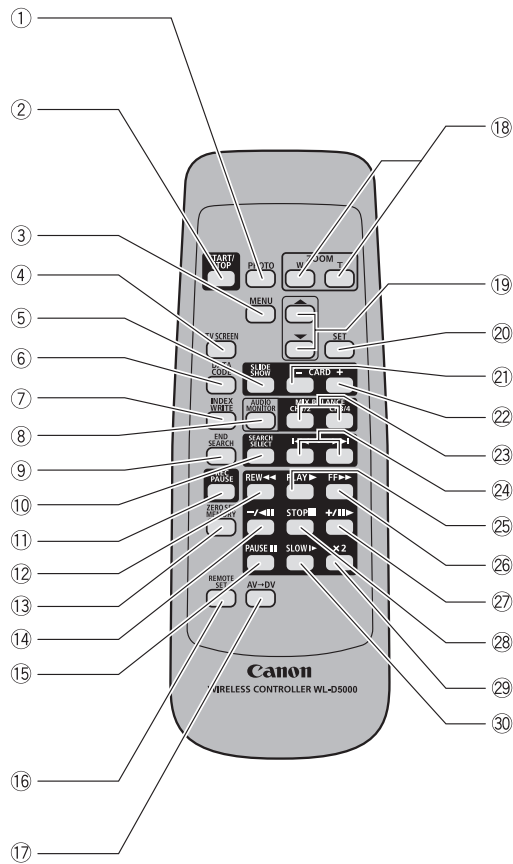

- ① PHOTO button (☐ 117)
- ② START/STOP button (☐ 34)
- ③ MENU button (☐ 31)
- ④ TV SCREEN button (☐ 76)
- ⑤ SLIDESHOW button (☐ 123)
- ⑥ DATA CODE button (☐ 113)
- ⑦ INDEX WRITE button (☐ 76)
- ⑧ AUDIO MONITOR button (☐ 86)
- ⑨ END SEARCH button (☐ 39)
- ⑩ SEARCH SELECT button (☐ 112, 113)
- ⑪ REC PAUSE button (☐ 89)
- ⑫ REW ◀◀ button (☐ 110)
- ⑬ ZERO SET MEMORY button (☐ 112)
- ⑭ -/◀▶ button (☐ 110)
- ⑮ PAUSE || button (☐ 110)

- ⑯ REMOTE SET button (☐ 114)
- ⑰ AV → DV button (☐ 90)
- ⑱ Zoom buttons (☐ 40)
- ⑲ Menu selection buttons (☐ 31)
- ⑳ SET button (☐ 31)
- ㉑ CARD - button (☐ 123)
- ㉒ CARD + button (☐ 123)
- ㉓ MIX BALANCE buttons (☐ 86)
- ㉔ ◀◀/▶▶ buttons (☐ 112, 113)
- ㉕ PLAY ▶ button (☐ 110)
- ㉖ FF▶▶ button (☐ 110)
- ㉗ +/▶▶ button (☐ 110)
- ㉘ STOP ■ button (☐ 110)
- ㉙ ×2 button (☐ 110)
- ㉚ SLOW |▶ button (☐ 110)

Preparing the Power Supply

Charging the Battery Pack

Disconnect the DC coupler from the compact power adapter before charging. Remove the terminal cover of the battery pack.

1. **Connect the power cord to the compact power adapter.**
2. **Plug the power cord into a power outlet.**
3. **Attach the battery pack to the compact power adapter.**
 - Press lightly and slide the battery pack in the direction of the arrow until it clicks.
 - The charge indicator starts flashing. The indicator will stay on when the charging is completed.
4. **When the charging is completed, remove the battery pack from the compact power adapter.**
5. **Unplug the power cord from the power outlet and disconnect it from the compact power adapter.**

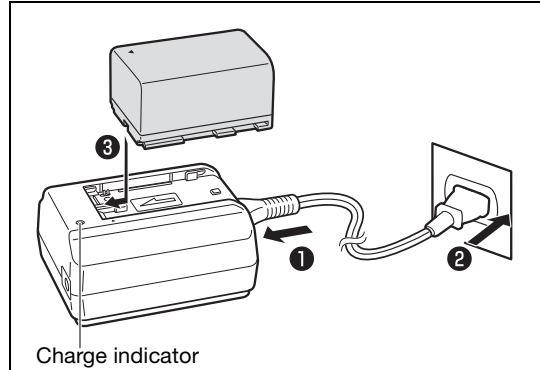

Attaching the Battery Pack

1. Turn the **POWER** dial to **OFF**.
2. **Attach the battery pack to the camcorder.**

Align the battery pack with the guideline and press lightly. Slide the battery pack up, in the direction of the arrow, until it clicks.
3. **Remove the battery pack after use.**

Holding the BATT. RELEASE button pressed down, slide the battery pack down to remove it.

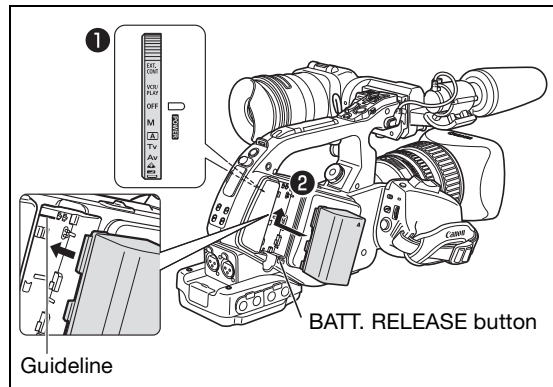

Using a Household Power Outlet

1. Turn the **POWER** dial to OFF.

2. Attach the DC coupler to the camcorder.

Press lightly and slide the DC coupler up, in the direction of the arrow until it clicks.

3. Connect the power cord to the compact power adapter.

4. Plug the power cord into a power outlet.

5. Connect the DC coupler to the compact power adapter.

6. Detach the DC coupler after use.

Holding the BATT. RELEASE button pressed down, slide the DC coupler down to remove it.

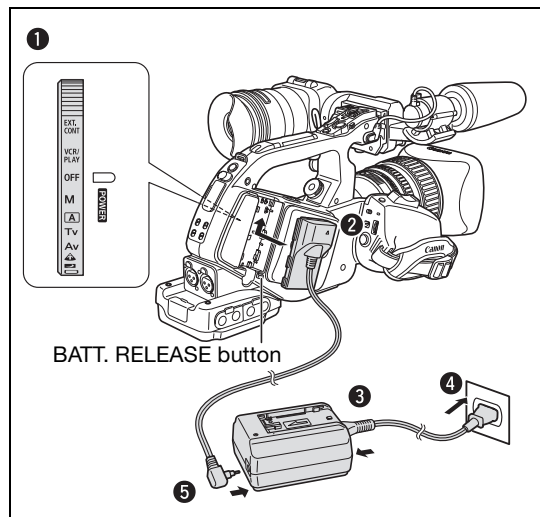

About the Built-in Rechargeable Lithium Battery

This camcorder has a built-in rechargeable lithium battery to retain the date, time and other settings. The built-in battery is recharged every time you use the camcorder. However, when you use the camcorder for only short periods or do not use it for a period of over 3 months, it will discharge completely. In that case, recharge the built-in battery by powering the camcorder from a power outlet and leaving it with the **POWER** dial set to OFF for at least 24 hours.



- Disconnect the DC coupler from the compact power adapter when charging a battery pack.
- Turn off the camcorder before connecting or disconnecting the compact power adapter.
- If the compact power adapter is used close to a TV, it may cause picture interference. Move the compact power adapter away from the TV or the antenna cable.
- Do not connect to the compact power adapter any products not expressly recommended for use with this camcorder.



- If you connect a faulty compact power adapter or battery pack, the charge indicator turns off and charging will stop.
- The charge indicator serves also as an indication about the charge status.
 - 0-50%: Flashes once per second
 - 50-75%: Flashes twice per second
 - More than 75%: Flashes 3 times per second
 - 100%: Continuously on
- We recommend charging the battery pack in temperatures between 10 °C and 30 °C. The charging time will vary depending on the surrounding temperature and the battery's initial charge condition.
- In cold places the effective usage time of the battery will decrease.
- We recommend that you prepare battery packs 2 to 3 times longer than you think you might need.
- To conserve battery power, turn off the camcorder instead of leaving it in record pause mode.

○ Charging, Recording and Playback Times

The following times are approximate and vary according to the charging, recording and playback conditions.

Battery Pack		BP-930	BP-945	BP-950G	BP-970G
Charging time with the CA-920 Compact Power Adapter		145 min.	220 min.	235 min.	320 min.
XL Hi8					
(HDV) Maximum Recording Time					
HD 20x L IS III Lens	Supplied color viewfinder	130 min.	195 min.	275 min.	375 min.
	FU-1000 monochrome viewfinder ²	100 min.	155 min.	215 min.	295 min.
HD 20x L IS II Lens	Supplied color viewfinder	130 min.	195 min.	275 min.	380 min.
	FU-1000 monochrome viewfinder ²	100 min.	155 min.	215 min.	300 min.
HD 6x L Lens	Supplied color viewfinder	135 min.	200 min.	285 min.	390 min.
	FU-1000 monochrome viewfinder ²	105 min.	160 min.	220 min.	305 min.
(HDV) Typical Recording Time¹					
HD 20x L IS III Lens	Supplied color viewfinder	75 min.	115 min.	165 min.	225 min.
	FU-1000 monochrome viewfinder ²	60 min.	95 min.	135 min.	185 min.
HD 20x L IS II Lens	Supplied color viewfinder	75 min.	115 min.	165 min.	230 min.
	FU-1000 monochrome viewfinder ²	65 min.	95 min.	135 min.	185 min.
HD 6x L Lens	Supplied color viewfinder	80 min.	120 min.	170 min.	235 min.
	FU-1000 monochrome viewfinder ²	65 min.	100 min.	140 min.	190 min.
(HDV) Playback Time (supplied color viewfinder)		155 min.	235 min.	335 min.	455 min.
(DV) Maximum Recording Time					
HD 20x L IS III Lens	Supplied color viewfinder	145 min.	220 min.	305 min.	420 min.
	FU-1000 monochrome viewfinder ²	110 min.	170 min.	240 min.	330 min.
HD 20x L IS II Lens	Supplied color viewfinder	145 min.	220 min.	310 min.	425 min.
	FU-1000 monochrome viewfinder ²	115 min.	175 min.	240 min.	330 min.
HD 6x L Lens	Supplied color viewfinder	150 min.	225 min.	310 min.	435 min.
	FU-1000 monochrome viewfinder ²	115 min.	175 min.	240 min.	340 min.
20x L IS Lens	Supplied color viewfinder	135 min.	205 min.	285 min.	390 min.
	FU-1000 monochrome viewfinder ²	105 min.	160 min.	225 min.	310 min.
16x Manual Zoom Lens	Supplied color viewfinder	150 min.	225 min.	310 min.	435 min.
	FU-1000 monochrome viewfinder ²	115 min.	175 min.	240 min.	340 min.
(DV) Typical Recording Time¹					
HD 20x L IS III Lens	Supplied color viewfinder	85 min.	125 min.	180 min.	245 min.
	FU-1000 monochrome viewfinder ²	65 min.	100 min.	140 min.	190 min.
HD 20x L IS II Lens	Supplied color viewfinder	85 min.	130 min.	180 min.	250 min.
	FU-1000 monochrome viewfinder ²	65 min.	100 min.	140 min.	195 min.
HD 6x L Lens	Supplied color viewfinder	90 min.	135 min.	185 min.	260 min.
	FU-1000 monochrome viewfinder ²	70 min.	105 min.	145 min.	205 min.
20x L IS Lens	Supplied color viewfinder	80 min.	120 min.	165 min.	230 min.
	FU-1000 monochrome viewfinder ²	60 min.	95 min.	130 min.	185 min.
16x Manual Zoom Lens	Supplied color viewfinder	90 min.	135 min.	185 min.	260 min.
	FU-1000 monochrome viewfinder ²	70 min.	105 min.	145 min.	205 min.
(DV) Playback Time (supplied color viewfinder)		175 min.	265 min.	370 min.	505 min.

¹ Approximate times for recording with repeated operations such as start/stop, zooming, power on/off. Actual time may be shorter.

² Optional.

Battery Pack		BP-930	BP-945	BP-950G	BP-970G
XLH1A					
(HDV) Maximum Recording Time					
HD 20x L IS III Lens	Supplied color viewfinder	140 min.	205 min.	290 min.	400 min.
	FU-1000 monochrome viewfinder ²	105 min.	160 min.	230 min.	310 min.
HD 20x L IS II Lens	Supplied color viewfinder	140 min.	210 min.	295 min.	405 min.
	FU-1000 monochrome viewfinder ²	105 min.	165 min.	230 min.	315 min.
HD 6x L Lens	Supplied color viewfinder	145 min.	215 min.	305 min.	420 min.
	FU-1000 monochrome viewfinder ²	110 min.	165 min.	240 min.	320 min.
(HDV) Typical Recording Time¹					
HD 20x L IS III Lens	Supplied color viewfinder	85 min.	125 min.	180 min.	245 min.
	FU-1000 monochrome viewfinder ²	65 min.	100 min.	140 min.	190 min.
HD 20x L IS II Lens	Supplied color viewfinder	80 min.	125 min.	175 min.	240 min.
	FU-1000 monochrome viewfinder ²	65 min.	100 min.	140 min.	190 min.
HD 6x L Lens	Supplied color viewfinder	80 min.	125 min.	180 min.	245 min.
	FU-1000 monochrome viewfinder ²	65 min.	100 min.	145 min.	195 min.
(HDV) Playback Time (supplied color viewfinder)		175 min.	265 min.	375 min.	510 min.
(DV) Maximum Recording Time					
HD 20x L IS III Lens	Supplied color viewfinder	150 min.	225 min.	325 min.	440 min.
	FU-1000 monochrome viewfinder ²	115 min.	180 min.	250 min.	340 min.
HD 20x L IS II Lens	Supplied color viewfinder	155 min.	230 min.	325 min.	450 min.
	FU-1000 monochrome viewfinder ²	115 min.	180 min.	250 min.	340 min.
HD 6x L Lens	Supplied color viewfinder	130 min.	205 min.	285 min.	390 min.
	FU-1000 monochrome viewfinder ²	105 min.	160 min.	225 min.	315 min.
20x L IS Lens	Supplied color viewfinder	140 min.	210 min.	300 min.	410 min.
	FU-1000 monochrome viewfinder ²	110 min.	165 min.	235 min.	315 min.
16x Manual Zoom Lens	Supplied color viewfinder	155 min.	235 min.	335 min.	455 min.
	FU-1000 monochrome viewfinder ²	120 min.	185 min.	255 min.	350 min.
(DV) Typical Recording Time¹					
HD 20x L IS III Lens	Supplied color viewfinder	90 min.	130 min.	190 min.	260 min.
	FU-1000 monochrome viewfinder ²	65 min.	105 min.	145 min.	195 min.
HD 20x L IS II Lens	Supplied color viewfinder	90 min.	135 min.	190 min.	260 min.
	FU-1000 monochrome viewfinder ²	70 min.	105 min.	145 min.	195 min.
HD 6x L Lens	Supplied color viewfinder	75 min.	115 min.	165 min.	230 min.
	FU-1000 monochrome viewfinder ²	60 min.	95 min.	130 min.	185 min.
20x L IS Lens	Supplied color viewfinder	85 min.	125 min.	175 min.	240 min.
	FU-1000 monochrome viewfinder ²	65 min.	100 min.	140 min.	185 min.
16x Manual Zoom Lens	Supplied color viewfinder	95 min.	140 min.	195 min.	270 min.
	FU-1000 monochrome viewfinder ²	70 min.	110 min.	150 min.	205 min.
(DV) Playback Time (supplied color viewfinder)		195 min.	290 min.	410 min.	560 min.

¹ Approximate times for recording with repeated operations such as start/stop, zooming, power on/off. Actual time may be shorter.

² Optional.

Preparing the Camcorder

Attaching and Detaching the Color Viewfinder Unit

Attaching the Color Viewfinder Unit

1. Slide the viewfinder unit onto the bracket and tighten the lock screw.

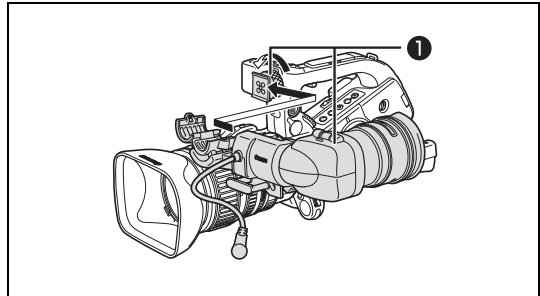

2. Connect the viewfinder cable to the EVF1 socket on the camcorder.

Insert the cable plug straight into the camcorder's socket.

3. Hook the viewfinder cable onto the cable clamp.

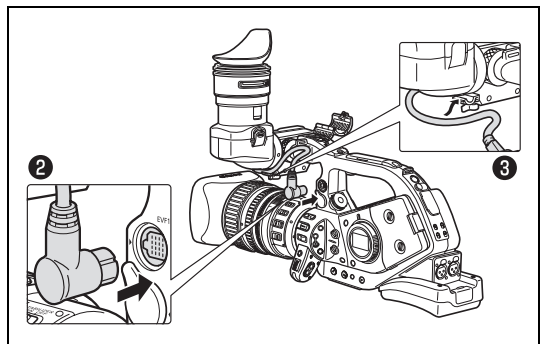

To use the optional FU-1000 Monochrome CRT Viewfinder Unit, connect it to the EVF2 socket on the camcorder instead.

Detaching the Viewfinder Unit

1. Detach the viewfinder cable.
2. Loosen the lock screw and slide the viewfinder unit off the bracket.

Attaching and Detaching the Eye Cup

You can change the position of the eye cup for use with either the left or right eye. Detach the eye cup and reattach it when changing the position of the eye cup for right or left eye use.

Attaching the Eye Cup

Align the hole for the dioptic adjustment lever with the lever, and pull the eye cup into position.

Right eye use

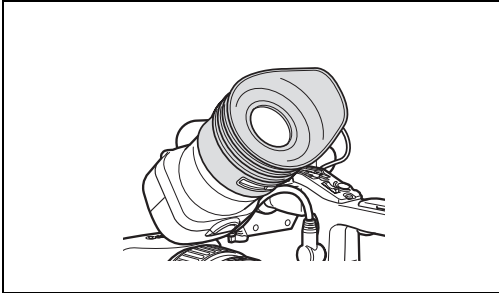

Left eye use



Detaching the Eye Cup

Detach the eye cup as shown in the illustration.

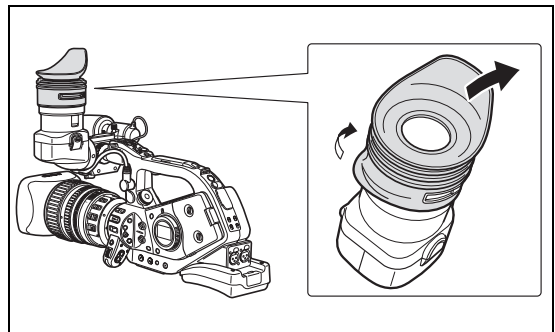

Adjusting the Position of the Viewfinder

The viewfinder position can be changed (right/left, forward/backward).

When storing the camcorder in the optional HC-3200 System Case, adjust the viewfinder to the right and lock it.

Right/Left Adjustment

Loosen the top lock screw, adjust the viewfinder to the right/left and tighten the screw.

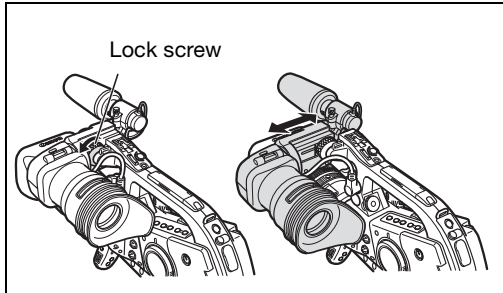

Forward/Backward Adjustment

Loosen the bottom lock screw, adjust the viewfinder forward/backward and tighten the screw.

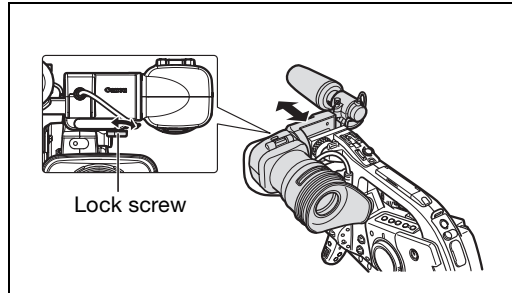

Dioptic Adjustment

Turn on the camcorder and adjust the dioptic adjustment lever.

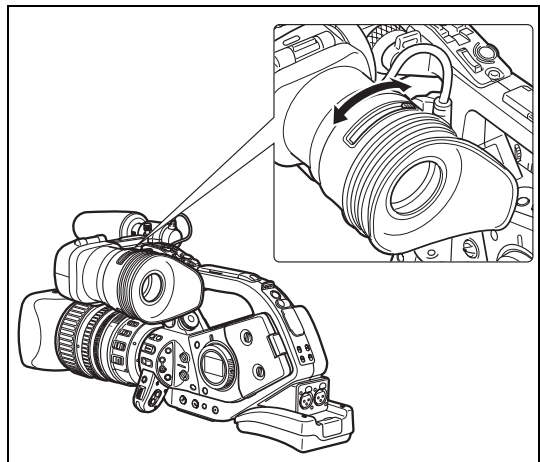

Do not let the viewfinder be exposed to direct sunlight or other strong light sources. The viewfinder LCD may become damaged due to concentration of the light by the lens. Pay special attention when mounting the camcorder on a tripod, or during its transportation.

Adjusting the Viewfinder

You can adjust the brightness, contrast, color and sharpness of the viewfinder. These adjustments will not affect your recordings.

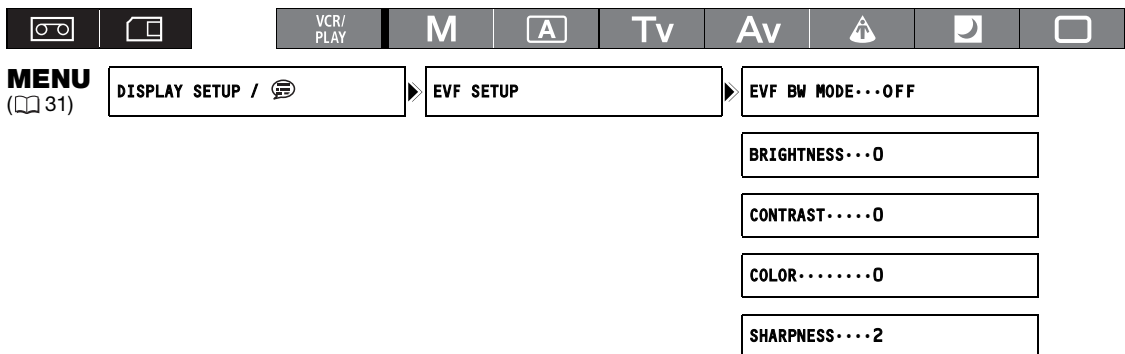

1. Press the **MENU** button.
2. Turn the **SELECT** dial to select **[DISPLAY SETUP/[icon]]** and press the **SET** button.
3. Select **[EVF SETUP]** and then select **[BRIGHTNESS]**, **[CONTRAST]**, **[COLOR]** or **[SHARPNESS]**.
4. Adjust the setting with the **SELECT** dial and press the **SET** button.
 - After the adjustment you will return to the **[EVF SETUP]** submenu. Change additional settings in the same way.
 - For more details regarding the **[EVF BW MODE]** setting refer to page 77.
5. Press the **MENU** button to close the menu.

Using the Viewfinder as LCD Panel

You can use the viewfinder as an LCD panel by opening the eyepiece adapter.

Press the lock release button and open the eyepiece adapter.

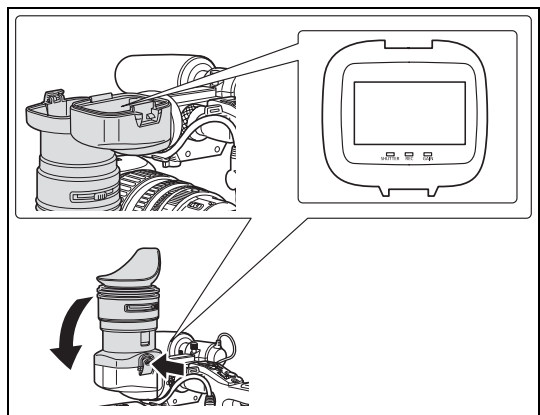

Make sure to close the eyepiece adapter when you are not using the viewfinder as an LCD panel.



The screen is slightly brighter when you open the eyepiece adapter.

Attaching the Microphone Unit

1. Loosen the microphone lock screw on the viewfinder unit, open the microphone holder and insert the microphone.
2. Align the mark on the microphone with the mark on the microphone holder and tighten the lock screw.
3. Plug the microphone cable to the camcorder's FRONT MIC terminals.

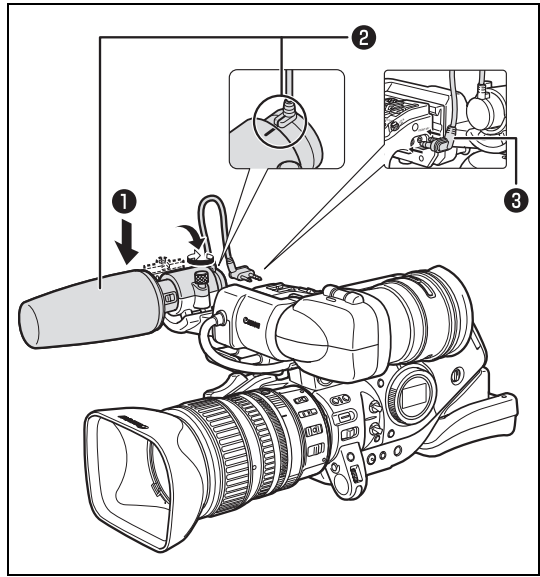

To use an external microphone with a diameter too small for the microphone holder to close securely, attach first the supplied adjustment band to the microphone holder and then insert the microphone.

Fastening the Grip Belt

Adjust the grip belt so that you can reach the zoom lever with your index and middle finger, and the Start/Stop button with your thumb.

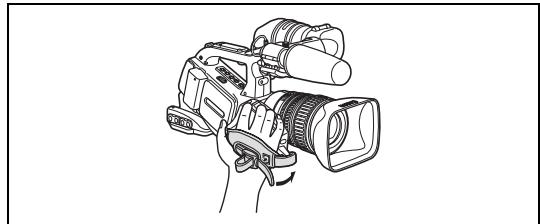

Attaching the Shoulder Strap

Pass the ends through the strap mount and adjust the length of the strap.

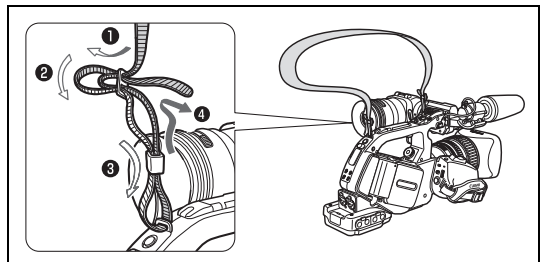

Be careful not to drop the camcorder when adjusting the strap or the grip belt.

Attaching the Adapter Holder

Attach the adapter holder to use the optional CH-910 Dual Battery Charger/Holder or a commercially available wireless microphone receiver.

1. Attach the adapter holder and secure it by tightening the screws.
2. Adjust the position of the support bars.

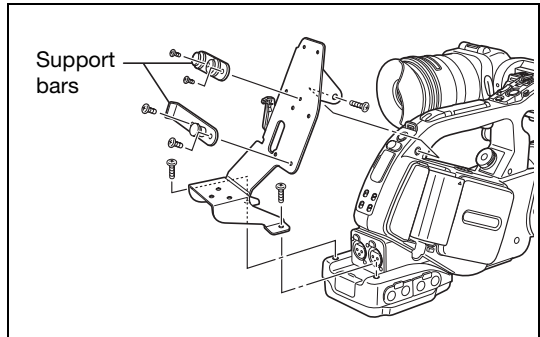

When using the optional CH-910, hook it onto the support bars and secure it with the stop lever. To detach the CH-910, press the stop lever in the direction of the arrow and pull the CH-910 off the support bars.

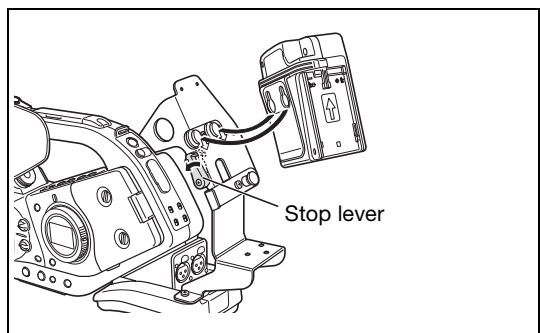

Preparing the Lens

Refer also to the instruction manual of the lens.

Mounting the Lens

1. Set the **POWER** dial to **OFF**.
2. Remove the dust caps from the camcorder and the lens.
3. Align the red mark on the lens with the red mark on the camcorder and turn the lens clockwise until it clicks.

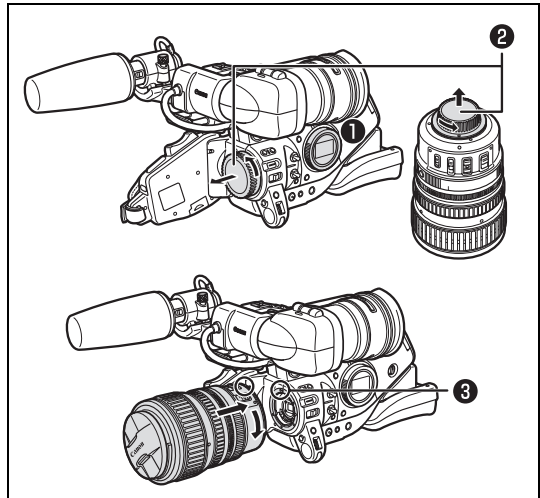

Removing the Lens

1. Set the **POWER** dial to **OFF**.
2. Slide the **LENS RELEASE** switch all the way in the direction of the arrow.
3. Turn the lens counter-clockwise until it stops and remove the lens.
4. Attach the dust caps to the camcorder and the lens.

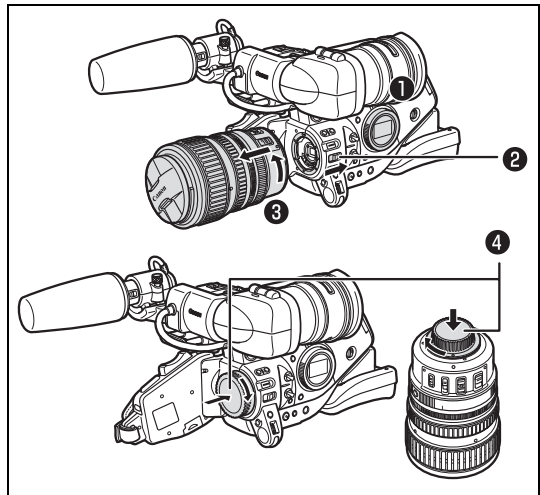

- Be careful not to drop the lens or camcorder when mounting or removing the lens.
- Avoid direct sunlight or strong light sources when mounting or removing the lens.
- The XL mount is not compatible with the VL mount.
- If you set the **POWER** dial to a recording mode without a lens attached, the lens warning icon “LENS” will flash in red on the screen.
- Do not touch the lens, lens mount and the interior of the mount, or expose them to dust or dirt. If necessary, clean the lens with a dry, soft lens-cleaning cloth. Make sure to turn off the camcorder while cleaning the lens.
- Proper operation cannot be guaranteed when recording in HDV standard with lenses that were not designed for HDV recording. If you attach such a lens to the camcorder, the messages “THIS LENS HAS NO STILL SHOOTING CAPABILITY” and “HD INCOMPATIBLE LENS” will appear.

- Proper operation cannot be guaranteed when recording in HDV standard with the optional Extender XL 1.6x. The message “HD INCOMPATIBLE LENS” will appear when using the extender, even with an HD-compatible lens.

Attaching the Lens Hood

Attach the lens hood to protect the lens and shade it from stray light.

1. Place the lens hood on the front of the lens and screw it clockwise until the Canon logo appears on top.

- Be careful not to deform the lens hood.
- Make sure that the lens hood is aligned with the thread.

2. Tighten the lock screw.

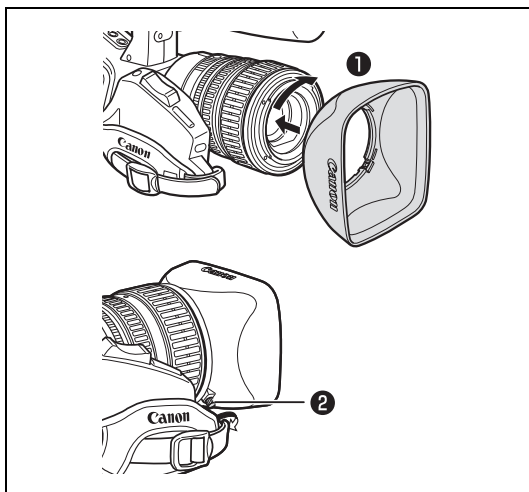

Adjusting the Flange Back (lenses without built-in flange back adjustment function)

The flange back can be adjusted to correct the focus while zooming to full telephoto or full wide-angle. The flange back can be adjusted automatically by the camcorder (AF) or manually (MF). The camcorder can store and back up flange back adjustment values for up to 10 different lenses.



Preparations

1. Point the camcorder to face a subject and secure it in place.

Place the camcorder at a distance of at least 1 m from the subject. Avoid subjects that are difficult to focus on at full wide-angle.

2. Zoom out to full wide-angle.

3. Set the **POWER dial to Av and set the aperture to full open.**

4. Zoom in to full telephoto.

Make sure the subject remains in the center of the frame at full telephoto as well as at full wide-angle.

5. Check that the exposure conditions are appropriate.

If necessary, use the ND filter.

AF Adjustment

1. Press the **MENU** button.
2. Turn the **SELECT** dial to select **[CAMERA SETUP]** and press the **SET** button.
3. Select **[FB]** and then select **[→ AF ADJUST]**.
4. When the confirmation screen appears, press the **SET** button to begin the adjustment.
5. Once the message “**FB ADJUSTMENT SUCCESSFUL**” is displayed, press the **MENU** button to close the menu.

MF Adjustment

1. Press the **MENU** button.
2. Turn the **SELECT** dial to select **[CAMERA SETUP]** and press the **SET** button.
3. Select **[FB]** and then select **[→ MF ADJUST]**.
4. When the confirmation screen appears, press the **SET** button to begin the adjustment.
5. The camcorder will zoom in to full telephoto. When the message “**ADJUST FOCUS & PUSH [SET]**” appears, focus as necessary and press the **SET** button.
6. The camcorder will zoom out to full wide-angle. When the message “**ADJUST FOCUS & PUSH [SET]**” appears, focus as necessary and press the **SET** button.
7. Once the message “**FB ADJUSTMENT SUCCESSFUL**” is displayed, press the **MENU** button to close the menu.



If an error message appears during the flange back adjustment, be sure to reset the FB adjustment value before readjusting the flange back.

Resetting the flange back adjustments

This procedure will reset the stored flange back adjustment value for the mounted lens.

1. Press the **MENU** button.
2. Turn the **SELECT** dial to select **[CAMERA SETUP]** and press the **SET** button.
3. Select **[FB]** and then select **[SET DEFAULT]**.
4. Select **[YES]** and press the **SET** button.
5. Press the **MENU** button to close the menu.



In the following cases the flange back cannot be adjusted correctly and the camcorder will return to the flange back adjustment selection screen.

- The camcorder cannot focus in AF adjustment.
- The lens was removed during the flange back adjustment.

Using the Wireless Controller

When you press the buttons on the wireless controller, point it at one of the camcorder's remote sensors.

The camcorder has 3 remote sensors: 2 at the front and 1 at the back.

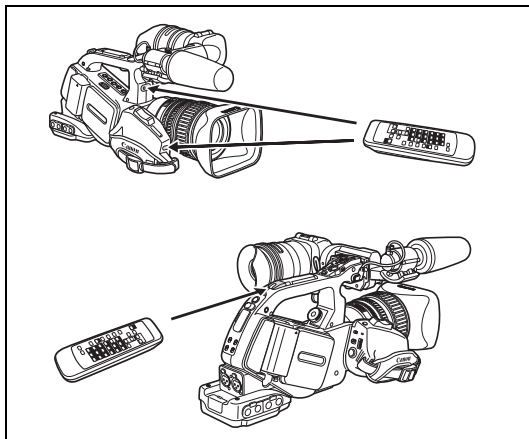

Inserting the Batteries

The wireless controller operates with two AA (R6) batteries.

1. Open the battery cover.
2. Insert the batteries following the + and - markings.
3. Close the battery cover.

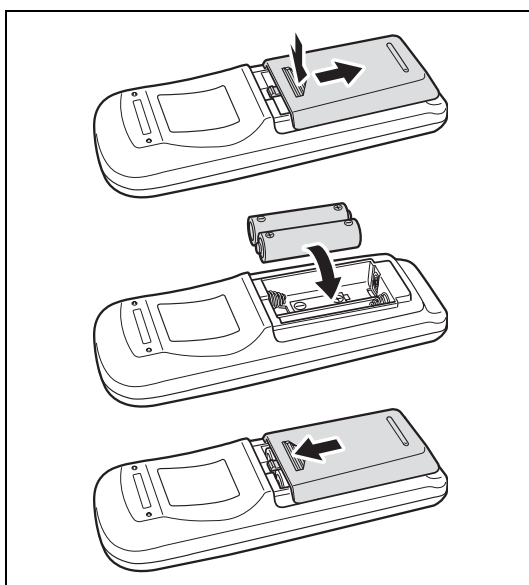

- The camcorder and wireless controller are equipped with 2 remote sensor modes (□ 114). If the wireless controller does not work, verify that the camcorder and wireless controller are set to the same mode.
- When the camcorder cannot be operated with the wireless controller, or when it can only be operated at very close range, replace the batteries. **Make sure to replace both batteries at the same time.**
- The wireless controller may not work properly when the remote sensor is located under strong light sources or direct sunlight.

Loading/Removing a Cassette

Use only videocassettes marked with the **Mini DV** logo. For recording in HDV we recommend you use videocassettes designed for HDV recording.

1. Slide the **EJECT** switch to open the cassette compartment cover.

The cassette compartment opens automatically.

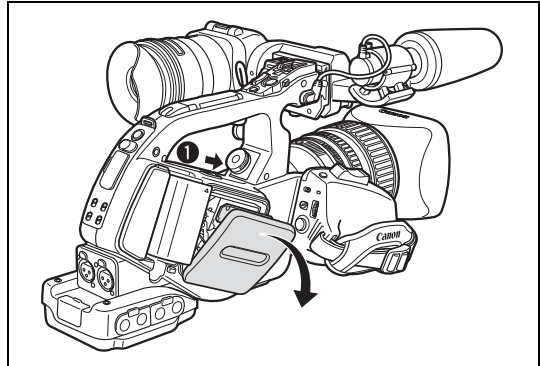

2. Load/remove the cassette.

- Insert the cassette straight, fully into the compartment with the window facing out.
- Remove the cassette by pulling it straight out.

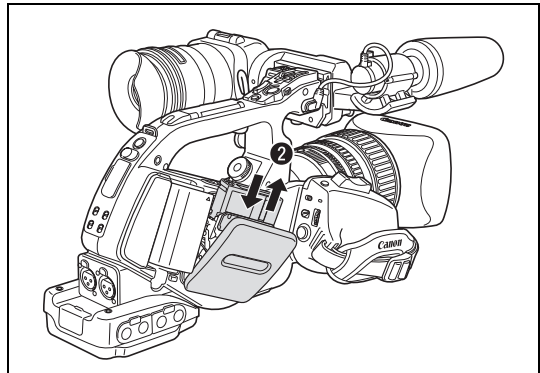

3. Close the cassette compartment cover.

Press the **PUSH** mark on the cassette compartment cover.

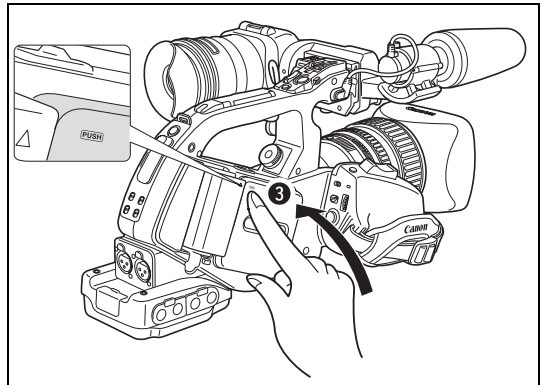



- Do not interfere with the cassette compartment while it is opening or closing automatically.
- Be careful not to get your fingers caught in the cassette compartment.



If the camcorder is connected to a power source, cassettes can be loaded/removed even if the **POWER** dial is set to OFF.

Inserting/Removing a Memory Card

You can use  SDHC (SD High Capacity) memory cards,  SD memory cards or MultiMedia Cards (MMC) with this camcorder.

Inserting the Card

1. Set the **POWER** dial to OFF.
2. Push the **OPEN** switch in the direction of the arrow to open the memory card slot cover.
3. Insert the memory card straight, all the way into the memory card slot.
4. Close the memory card slot cover.
Do not force the cover closed if the card is not correctly inserted.

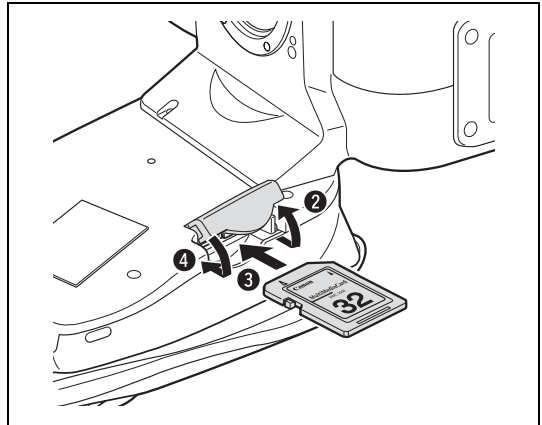

Removing the Card

Do not forcefully remove the memory card without first pushing it in to release it.

1. Make sure that the **CARD** access indicator is not flashing and set the **POWER** dial to OFF.
2. Push the **OPEN** switch in the direction of the arrow to open the memory card slot cover.
3. Push the memory card once to release it and then remove the memory card.
4. Close the memory card slot cover.

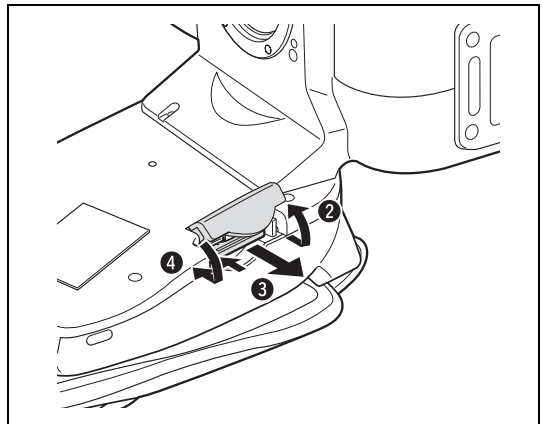

- If you use memory cards other than the supplied one, make sure to initialize them with the camcorder (□ 127).
- Turn off the camcorder before inserting or removing a memory card. Inserting/removing the memory card with the camcorder on may result in permanent data loss.



- SDHC and SD memory cards have a write-protect switch to prevent their accidental erasure. When this switch is set to the LOCK position, images cannot be recorded on or deleted from the memory card.
- Proper operation cannot be guaranteed for all memory cards.
- **About SDHC Memory Cards:** SDHC is the new type of SD memory card with capacities over 2 GB. Please note that the specifications of SDHC memory cards are different from those of regular SD cards and you will not be able to use memory cards of over 2 GB with devices that do not support SDHC. However, SDHC devices (including this camcorder) are backward compatible and you can use regular SD cards with them.



Changing Settings with the MENU Button

Many of the camcorder's functions can be changed from the on-screen menu.

Selecting Menus and Settings

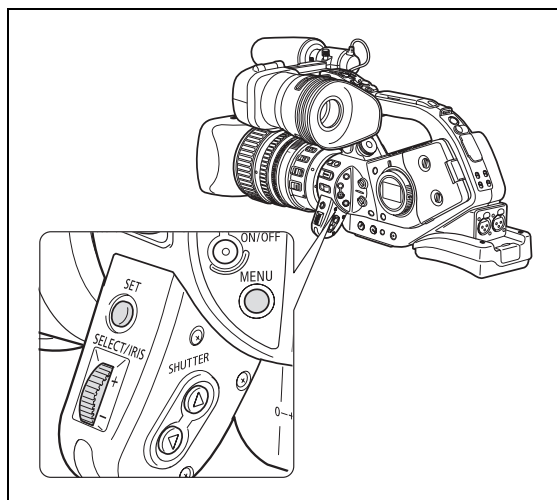
1. Press the **MENU** button to open the menu.
2. Turn the **SELECT** dial to select a submenu and press the **SET** button.
3. Turn the **SELECT** dial to select a menu item and press the **SET** button
4. Turn the **SELECT** dial to select a setting option and press the **SET** button.
5. Press the **MENU** button to close the menu.



- The , **SET** and **MENU** icons displayed at the bottom of the screen will give you additional indications about the function of these controls in specific situations.
- You may find it more convenient to use the wireless controller to operate the menu. Press the **MENU** button on the wireless controller to open or close the menu. Use the menu selection buttons  of the wireless controller instead of the **SELECT** dial, and press the **SET** button on the wireless controller to save the settings or make a selection.
- Unavailable items will appear grayed out.
- Pressing the **MENU** button at any time closes the menu.

Date/Time and Language Settings

Set the time zone, date and time when you first start using your camcorder, or if the built-in rechargeable battery has discharged completely.

Setting the Time Zone/Daylight Saving Time

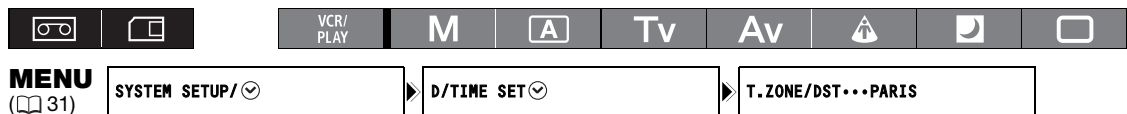

1. Press the **MENU** button.
2. Turn the **SELECT** dial to select [**SYSTEM SETUP/**] and press the **SET** button.
3. Select [**D/TIME SET**] and then select [**T.ZONE/DST**] and press the **SET** button.
The time zone setting appears. The default setting is Paris.
4. Turn the **SELECT** dial to select the setting option that matches your time zone and press the **SET** button.
To adjust for daylight saving time, select the time zone marked with a ☀.

Setting the Date and Time

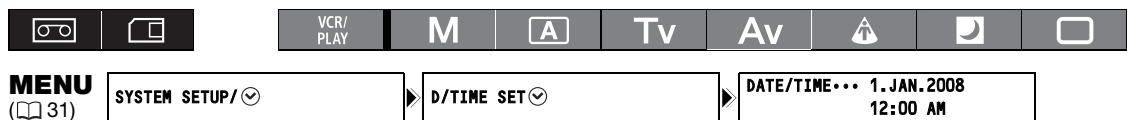

5. Select [**D/TIME SET**] and press the **SET** button.
The year display starts flashing.
6. Turn the **SELECT** dial to select the year, and press the **SET** button.
 - The month starts flashing.
 - Set the rest of the date and time in the same way.
7. Press the **MENU** button to close the menu and start the clock.

Displaying the Date and Time while Recording

You can display the date and time in the lower left corner of the screen.

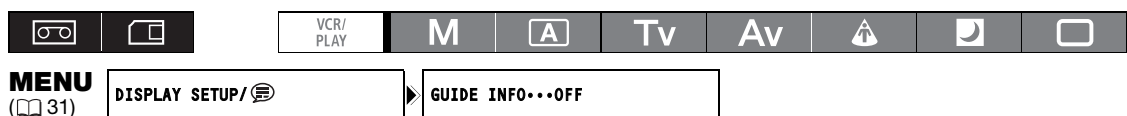

Open the menu and select [**DISPLAY SETUP/**]. Select [**GUIDE INFO**], set it to [**D/T DISPLAY**] and close the menu.



If you do not use the camcorder for a period of approximately 3 months, the built-in rechargeable battery will discharge completely and the date and time settings will be lost. In that case, recharge the built-in battery (16) and set the time zone, date and time again.

Changing the Date Format

You can select between three date formats: [JAN. 1, 2008], [1. JAN. 2008] and [2008. 1. 1].

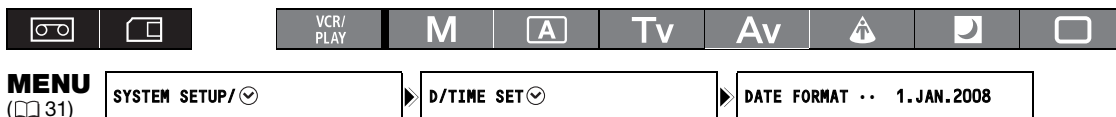

Open the menu and select [SYSTEM SETUP/☑]. Select the [D/TIME SET☑] submenu and then select [DATE FORMAT]. Select a date format and close the menu.

Changing the Display Language

The default language for displays and menu items is English. The language can be changed to German, Spanish, French, Italian, Polish, Russian, simplified Chinese or Japanese.



To change the display language, open the menu and select [DISPLAY SETUP/🗨]. Select [LANGUAGE🗨], select a language and close the menu.



- If you have mistakenly changed the language, follow the 🗨 mark next to the menu item to change the setting.
- The displays **MENU** and **SET** at the bottom of the screen refer to the names of buttons on the camcorder and will not change regardless of the language selected.

Recording

Before You Begin Recording

Make a test recording first to check if the camcorder operates correctly. If necessary, clean the video heads (144).

The default recording standard is HDV. About the audio recording, refer to the relevant chapter (53).

Recording



1. Remove the lens cap.
2. Press the lock button and set the **POWER** dial to a recording program.

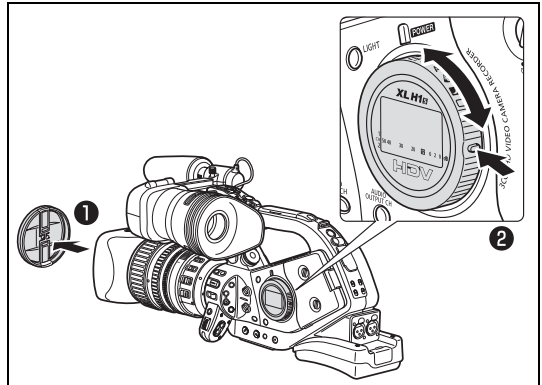

3. Press the Start/Stop button to begin recording.
 - The red REC indicator on the viewfinder and the tally lamps light up.
 - Press the Start/Stop button again to pause recording.

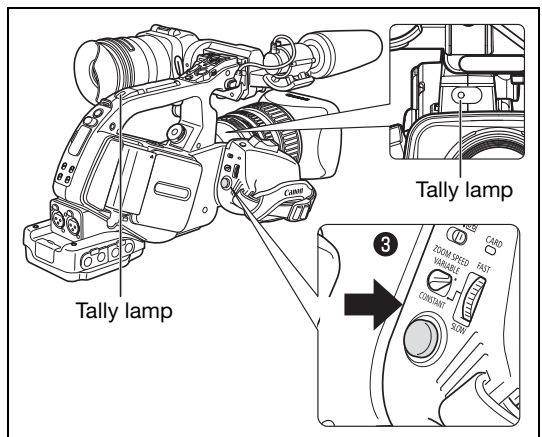

When You Have Finished Recording

1. Set the **POWER** dial to OFF.
2. Replace the lens cap.
3. Remove the cassette.
4. Disconnect the power source.



The end search, date search and index search functions may not work correctly if you mix recordings in HDV and DV standards on the same tape. We recommend not mixing recordings in different standards on the same tape.



- After inserting a cassette, wait until the tape counter stops completely before you start recording.
- Turn the **POWER** dial to OFF if you do not intend to use the camcorder for a long time.
- If you do not remove the cassette, you can record the next scene without any noise or blank sections between recordings even if you turn the camcorder off.

Low-angle Recording

The carrying handle is equipped with a duplicate set of recording and zoom controls, ideal for low-angle recording. Slide the LOCK switch in the direction of the arrow  to prevent the accidental operation of these controls.

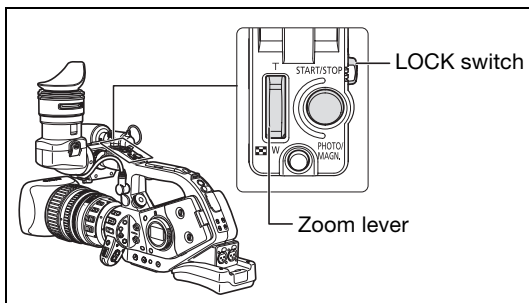

Power Saving Mechanisms

STANDBY Button

Press the STANDBY button and hold it pressed down for more than 1 second in record pause or VCR stop mode to enter the standby mode. The message “ENTERING “POWER STANDBY”” will be displayed before the camcorder enters the standby mode. In standby mode, power will be shut down to the camera and recorder sections but camera settings (including exposure lock and color bars settings) will be retained. Press the STANDBY button again to turn the camcorder on.

Power Save Function

In order to protect the tape and video heads, the camcorder will enter the power save mode (VCR stop) after 4 minutes 30 seconds in record pause mode. If left 30 more seconds without any operation, the camcorder will automatically shut off. Turn off the power save function with [SYSTEM SETUP] ► [POWER SAVE] setting (□ 132) if you wish to make adjustments without worrying about losing your settings as a result of the automatic shut-off.

Once the camcorder entered the power save mode, press the Start/Stop button to start recording or press one of the custom keys (□ 75) to which the [VCR STOP] function was assigned, to return to record pause mode. If the camcorder automatically shut off (after 5 minutes), turn the **POWER** dial to OFF and then back to one of the recording programs.

VCR Stop Function

You can assign the [VCR STOP] function to either custom key (□ 75). In VCR stop mode the camcorder is only partially turned off. The camera section is powered normally while the recorder section is shut off. When you press the assigned custom key, you can make adjustments to the camera section as long as necessary without worrying about the 5-minute shut-off timer of the power save function. To return to record pause mode, press the assigned custom key again.

Screen Displays while Recording



① Time code

Indicates the recording time in hours, minutes, seconds and frames.

② Remaining tape

Indicates the remaining time on the tape in minutes. “END” will appear when the tape reaches the end.

- When the time left is less than 15 seconds, the remaining tape time may not appear.
- Depending on the type of tape, the remaining time displayed may not be accurate. In any case, you will be able to record on the tape the number of minutes that appears on the cassette's label (for example, 85 minutes).

③ Remaining battery charge

The battery symbol indicates the charge status of the battery pack.



- The flashing battery symbol starts flashing in red when the battery pack is empty.
- When you attach an empty battery pack, the power may turn off without displaying the flashing battery symbol.
- The actual battery charge may not be indicated accurately depending on the condition under which the battery pack and camcorder are used.

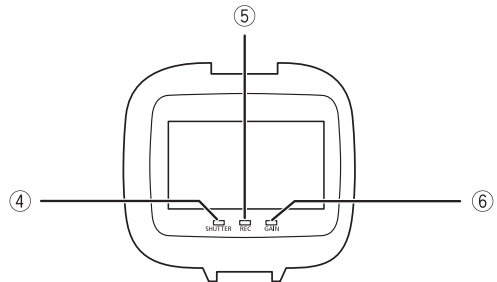

④ SHUTTER indicator

Lights up when recording with a shutter speed other than 1/50.

⑤ REC indicator

Lights up while recording.

The REC indicator starts flashing when the remaining time on the tape is less than 5 minutes (it does not flash if the remaining tape information is not displayed on the screen).

⑥ GAIN indicator

Lights up when the AGC (auto gain control) is set to either -3 dB or +3 dB or higher.

⑦ Reference guides

With the [DISPLAY SETUP/] ▶ [MARKERS], [ASPECT GUIDE] and [SAFETY ZONE] settings you can display reference guides to help you frame the subject more accurately.

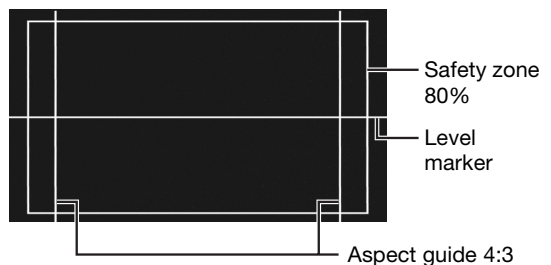

Selecting the On-Screen Displays

You can select the amount of information shown on the screen from full, partial or no display. Repeatedly pressing the EVF DISPLAY button will cycle through the options in the following sequence.

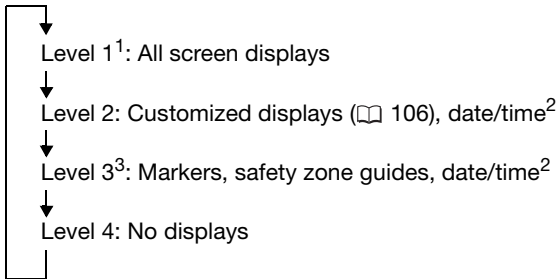
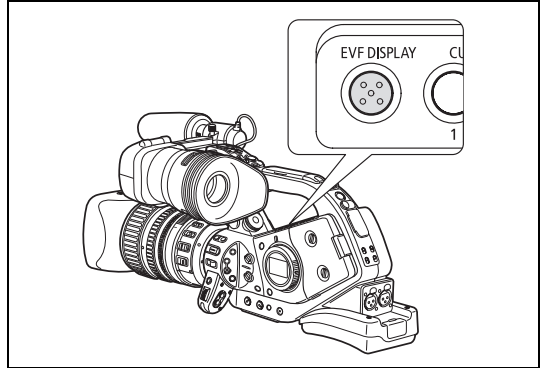

¹ This level cannot be selected if [SYSTEM SETUP/☺] ▶ [ALL DISPLAY] is set to [DISABLE].

² If [DISPLAY SETUP/☺] ▶ [GUIDE INFO] is set to [D/T DISPLAY], the date and time will be displayed; if it is set to [CUSTOM KEYS], the functions currently assigned to the custom keys will be displayed instead.

³ This level cannot be selected if [DISPLAY SETUP/☺] ▶ [MARKERS], [SAFETY ZONE] and [GUIDE INFO] are all set [OFF].



The camcorder's on-screen displays will also appear on a connected external TV or monitor.

Reviewing the Recording



In record pause mode, this function allows you to review the last few seconds of your recording.

Press and release the  (record review) button.

The camcorder rewinds the tape, plays back the last few seconds, and returns to record pause mode.

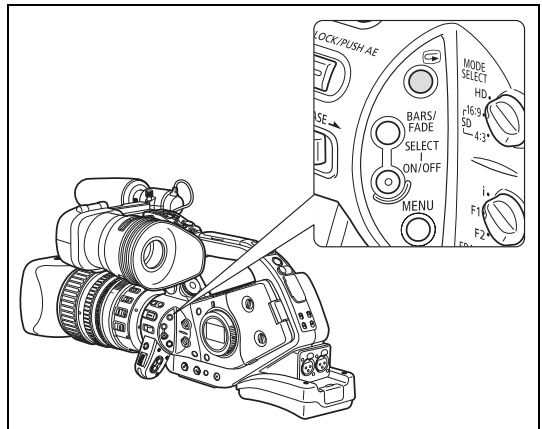

If the current video signal standard is different from the signal standard in which the tape was recorded, the recording will not be played back correctly.

Selecting the Signal Standard and Aspect Ratio

You can select the signal standard of your recording (high definition or standard definition) and, for standard definition recordings, also the aspect ratio of the recording. Since the camcorder's screen has an aspect ratio of 16:9, when you set the MODE SELECT switch to SD 4:3 the picture will appear in the center of the screen with black sidebars.



Change the position of the MODE SELECT switch.

- HD: To record on the tape in HDV standard or to use the camcorder as a high-definition (HD) camera.
- SD 16:9, SD 4:3: To record on the tape in DV standard or to use the camcorder as a standard-definition (SD) camera. Select the aspect ratio as desired.

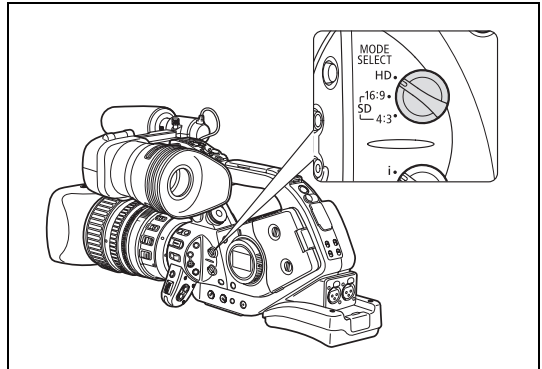

- If the custom function [LED] is not set to [OFF], the MODE SELECT switch will light up in blue when set to HD.
- If the position of the MODE SELECT switch is changed while recording, the standard/aspect ratio will not change immediately; it will change once you pause the recording.
- When you play back 16:9 recordings, the TV set will switch automatically to widescreen mode if it is compatible with the WSS system. Otherwise, change the aspect ratio of the TV manually.
- To play back on a standard TV set with 4:3 aspect ratio, set [SIGNAL SETUP] ► [LETTERBOX] to [ON] (129).
- When recording in 4:3, you can attach the optional RC-72 Ratio Converter (0.8x) to get the same angle of view of the 16:9 aspect ratio. (Note that not all XL lenses are compatible with the RC-72.)

Locating the End of the Last Scene

You can use this function to locate the end of the last recorded scene.



Press the **END SEARCH** button.

- **→|** appears.
- The camcorder rewinds/fast forwards the tape, plays back the last few seconds of the recording and stops the tape.
- Pressing the button again cancels the search.

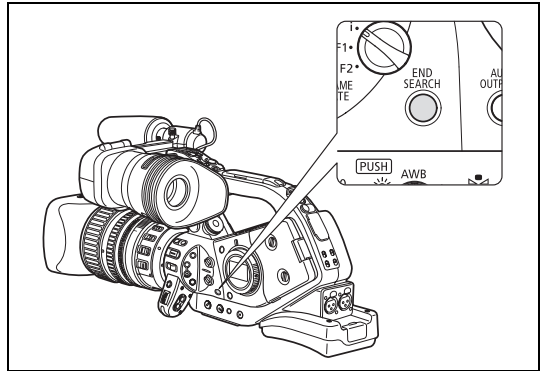

- The end search function cannot be used once you remove the cassette.
- The end search function may not work correctly if there is a blank section between recordings or if you mixed recordings in HDV and DV standards on the same tape.

Zooming

You can operate the zoom using the zoom lever on the side grip or the one on the carrying handle. You can also use the zoom ring on the lens or the zoom buttons on the wireless controller. With the customized functions (☐ 100) you can change the direction and response sensitivity of adjustment when the zoom ring is used, change the zoom speed and select the zoom indicator (graphic or numeric).

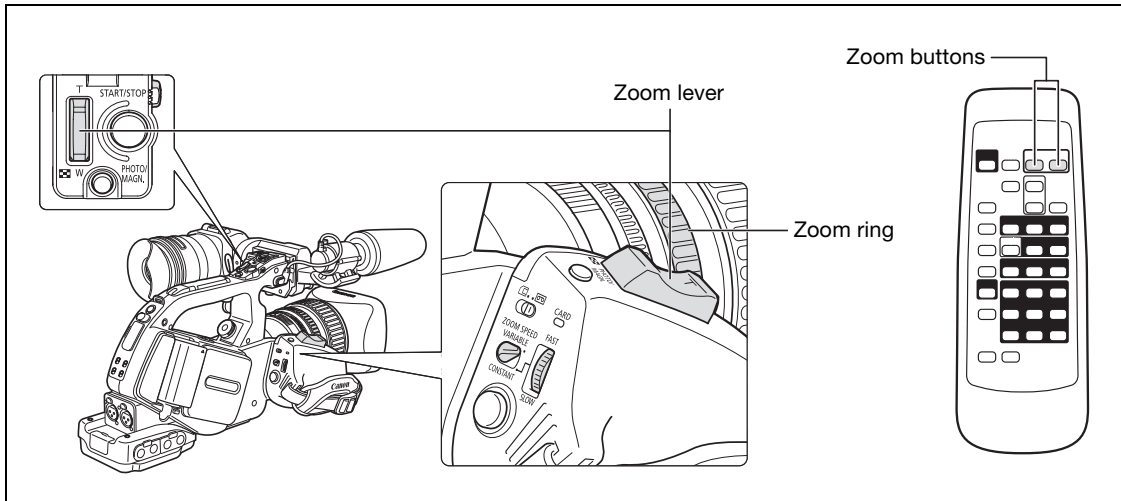

Move the zoom lever toward **W** to zoom out (wide-angle). Move it toward **T** to zoom in (telephoto).

Zoom Speed

Zoom lever on the side grip:

When the ZOOM SPEED switch is set to CONSTANT, the zoom speed will be constant at one of 16 zoom speed levels (the current zoom speed level will appear next to the zoom indicator). Turn the ZOOM SPEED dial toward FAST to select a faster zoom speed level (higher number); turn it toward SLOW to select a slower zoom speed level (lower number).

When the ZOOM SPEED switch is set to VARIABLE, the zoom speed will depend on how you operate the zoom lever: press gently for a slower zoom; press harder for faster zooms.

Approximate zoom speeds using the HD 20x L IS III lens (from full wide-angle to full telephoto):

ZOOM SPEED switch	Zoom speed level	Custom function [ZOOM SPEED] setting		
		[NORMAL] ¹	[SLOW]	[FAST]
CONSTANT	Level 1	5 min.	3 min.	1 min.
	Level 16	4.3 sec.	2 sec.	1.2 ² sec.
VARIABLE	—	1.2 ² – 60 sec.		

¹ Default setting when recording movies. When recording still images, the default setting is [FAST].

² When the zoom speed is too fast (less than 2 seconds end-to-end), the camcorder will have more trouble focusing automatically while zooming.

Zoom ring: The zoom speed depends on how fast you turn the zoom ring.

Zoom buttons on the carrying handle: The zoom speed is constant and can be set to one of 16 zoom speed levels. Set the ZOOM SPEED switch to CONSTANT and change the zoom speed level as described previously.

Zoom buttons on the supplied wireless controller: The zoom speed is constant and cannot be adjusted.

i When a fixed focal length lens is used, no zoom-related indications will appear on screen.

Zoom Preset (lenses with zoom preset function)

This function enables any given zoom position to be memorized. Later, you can return to the preset zoom position instantly.

Presetting the Zoom



1. Set the POSITION PRESET switch to ZOOM.

2. Move the POSITION PRESET ON/SET switch to SET.

The preset zoom position appears in yellow on the zoom indicator.

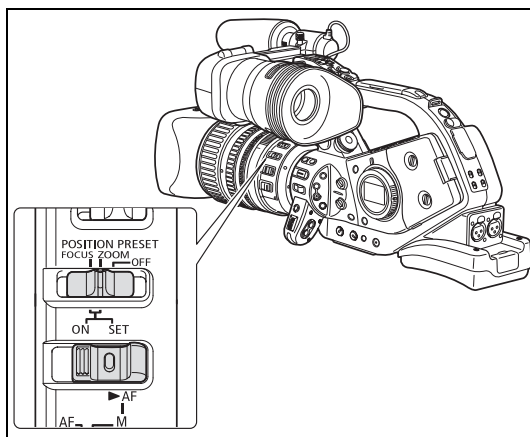

Returning to the Preset Zoom Position

Move the POSITION PRESET ON/SET switch to ON.

The camcorder returns to the preset zoom position.

- i**
- The preset setting is canceled when you attach the optional Extender XL 1.6x or mount a lens with a different magnification.
 - To return to the preset zoom position the camcorder uses the speed set for the constant zoom speed (when the ZOOM SPEED switch is set to CONSTANT).

Adjusting the Focus

Functions in this chapter are explained using the HD 20x L IS III lens. If you are using a different lens, refer also to the instruction manual of the lens.

The camcorder can be set to Autofocus or Manual Focus.

Autofocus

In addition to the usual autofocus, the camcorder has also a Push-AF function to allow for temporary autofocus while focusing manually.

Manual Focus

With the customized functions (☞ 100) you can change the direction and response sensitivity of adjustment when the focus ring is used. To make it easier to focus manually, you can also make use of the Peaking and Magnifying functions (☞ 44).



Autofocus

The autofocus is activated when the focus mode switch is set to AF. The camcorder uses the TTL autofocus system with a focusing range of 2 cm (at full wide-angle, measured from the front of the lens barrel) to ∞ .

The camcorder focuses on the subject in the center of the screen.

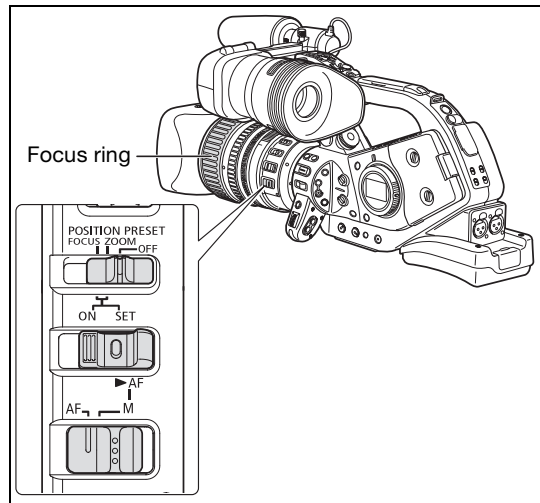

Temporary Focus Override

Even while in autofocus mode, turn the focus ring to temporarily focus manually.

The camcorder will return to autofocus as soon as you release the focus ring.

Push AF (using the HD 20x L IS III lens)

In manual focus mode, set the POSITION PRESET switch to OFF. Move the ► AF switch to ► AF and hold it.

The autofocus is activated as long as you hold the switch in the ► AF position.



When recording under bright conditions, the camcorder closes down the aperture. When the aperture value used is too large, the picture may appear blurred. If you are using a lens with a built-in ND filter, turn the ND filter on/off according to the screen display (☞ 47).



- In 25F mode, autofocus takes longer than in 50i mode.
- When recording under dark conditions, the focusing range narrows and the picture may appear blurred.

- Autofocus may not work well on the following subjects. In that case, focus manually.
 - Reflective surfaces
 - Subjects with low contrast or without vertical lines
 - Fast moving subjects
 - Through dirty or wet windows
 - Night scenes

Manual focus



1. When using a lens with autofocus function, set the focus mode switch to M.

- “MF” appears.
- When a lens without autofocus function is used, “MF” will not appear.

2. Zoom in to telephoto.

3. Turn the focus ring to adjust the focus.

With the customized functions (☐ 100) you can change the direction and response sensitivity of adjustment when the focus ring is used.

4. Operate the zoom to reframe the subject.

If you focus manually and then leave the camcorder with the power turned on, the focus on the subject may be lost after a while. This possible slight shift in

focus is a result of the internal temperature rising in the camcorder and lens. Check the focus before resuming shooting or adjust the flange back as necessary (☐ 26).

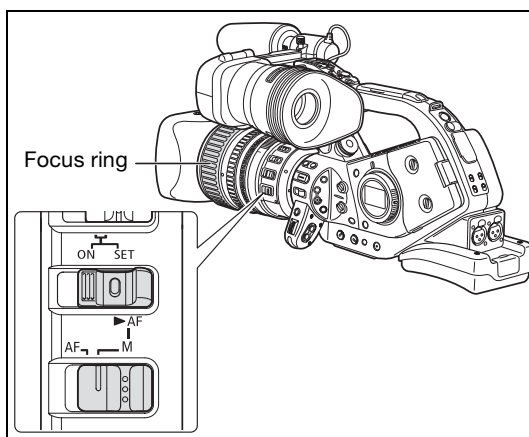

- Manual focus cannot be selected in ☐ Easy Recording mode. Even if you set the focus mode switch to M, the autofocus will still be activated.
- When using a lens designed for HDV recording, the focusing distance to the subject will be displayed for approx. 3 seconds when you switch from autofocus to manual focus or when you operate the focus ring in manual focus mode. It will also be displayed with the focus preset. With the custom function [OBJ DST UNIT] (☐ 100) you can change the units for the distance display (meter or feet) and with the custom display (☐ 106) you can select when to display this information (always, never, or only upon the operation of the focus ring).
 - The focusing distance will not be displayed when the optional Extender XL 1.6x is attached to the camcorder.
 - Use the focusing distance display as an estimate; when the distance reading is not considered very precise it will be displayed in gray. ∞: Infinity focus ∞-: Over infinity focus.
- You can simultaneously zoom and focus manually. If the camcorder is in AF mode, the autofocus will be reactivated when you finish the operation.

Using the Focus Assist Functions (Peaking and Magnifying)

In order to make manual focusing easier, you can use two assist functions: Peaking emphasizes the outlines of the subject creating a clearer contrast, and Magnifying enlarges the image on the screen. You can also combine both for greater effect.

With the custom function [FAST BW-MOD] (☐ 100) you can set the display to change automatically to black & white while using the focus assist functions. The screen of an external monitor or viewfinder connected to the EVF2 socket will show the exact same picture as displayed on the camcorder's viewfinder screen.

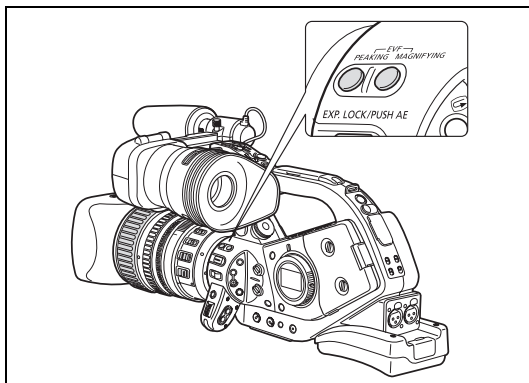

Peaking

While recording or in record pause, press the EVF PEAKING button.

- **PEAK 1** appears and the outlines of the subject will be emphasized.
- Press the button again to change the Peaking level to **PEAK 2** ; press once more to cancel the function.



- The Peaking function will not affect your recordings.
- The gain and frequency of peak levels **PEAK 1** and **PEAK 2** can be set independently with the [DISPLAY SETUP/☺] ▶ [PEAKING SETUP] setting.

Magnifying

In record pause, press the EVF MAGNIFYING button.

- "MAGN." appears and the central part of the screen will be magnified approximately 2x.
- Press the button again to cancel the function.



- The magnified picture will be output as is to the HD/SD SDI terminal (**EXLHIS** only) and the HDV/DV terminal.
- With the custom function [CUSTOM REC] (☐ 100) you can select to have the magnified picture recorded on the tape (**CAMERA** mode only) as it is, or to cancel the Magnifying function when you start recording video or record a still image on the memory card. In **CAMERA-CARD** mode, the Magnifying function will always be canceled when you press the PHOTO button.
- You can use the custom keys (☐ 75) or the [SYSTEM SETUP/☺] ▶ [MAGN.B.LOCK] setting to prevent the accidental operation of the EVF MAGNIFYING button. With the custom function [BUTTONS OPER.1] (☐ 100) you can also change the operation of the EVF MAGNIFYING button (normal or long press).

Focus Preset (lenses with focus preset function)

This function enables a focus position to be memorized. Later, you can return to the preset focus position instantly. You can also select the speed at which the camcorder returns to the preset focus position.

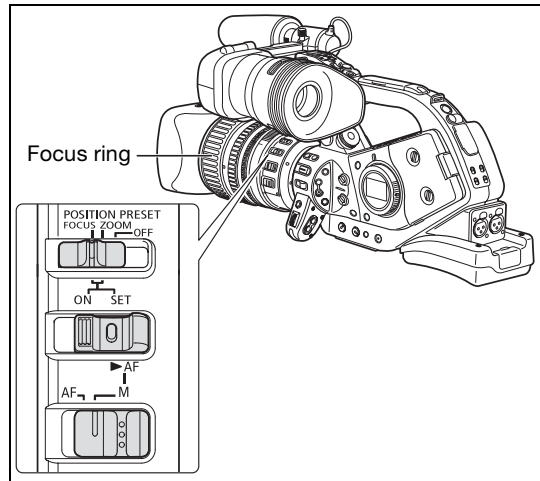

Presetting the Focus

- 1. Set the focus mode switch to M.**
“MF” appears.
- 2. Set the POSITION PRESET switch to FOCUS.**
The focus preset speed currently selected appears.
- 3. Adjust the focus with the focus ring.**
- 4. Move the POSITION PRESET ON/SET switch to SET.**
“MF” and the focus preset speed display turn yellow.

Setting the Focus Preset Speed

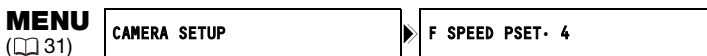

Open the menu and select [CAMERA SETUP]. Select [F SPEED PSET], select a setting option and close the menu.

4 is the fastest speed; 1 is the slowest.

Returning to the Preset Focus position

Move the POSITION PRESET ON/SET switch to ON.

The camcorder returns to the preset focus position.

Macro Shooting (Focus Limit)

Usually the camcorder's focus range allows macro shooting. You can activate the focus limit to restrict the focus range. Using the HD 20x L IS III lens, the focus range 10 cm - ∞ (at full wide-angle) is limited to 1 m - ∞ (throughout the entire zoom range).



MENU

( 31)

CAMERA SETUP

FOCUS LIMIT...OFF

Open the menu and select [CAMERA SETUP]. Select [FOCUS LIMIT], set it to [ON ] and close the menu.

 appears.



The focus limit will be canceled in the following cases.

- If the lens attached has an independent macro switch.
- If the lens attached does not support the macro setting being changed from the camcorder.
- When there is no lens attached.

Using the ND Filter (lenses with built-in ND filter)

When recording in bright surroundings, the camcorder will set a small aperture value and the picture may appear blurred. When using a lens with a built-in ND filter, turn the ND filter on/off according to the screen display.

With the HD 20x L IS III lens: Press the ND filter unlock button and turn the ND filter operating ring.

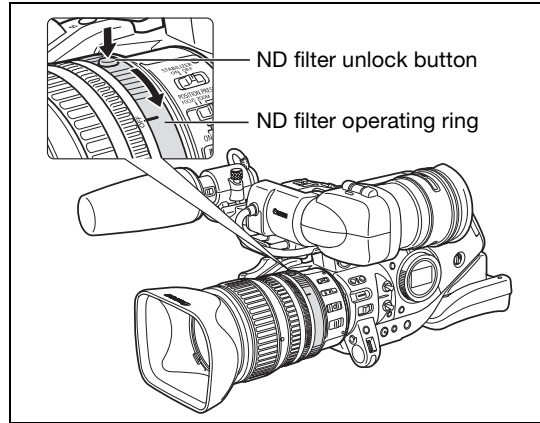

When using a recording program other than **M** Manual and if the GAIN dial is set to A, the following displays appear:

Screen display	What it means	What you should do
No display	ND filter is not activated	–
“ND”	ND filter is activated ¹	–
“ND ON ” flashes	ND filter required	Turn on the ND filter
ND “ ON ” flashes	Lenses with single-density ND filters (ON/OFF): External ND filter required. Lenses with selectable ND filter density: Higher density setting or external ND filter required.	Set the ND filter to a higher density setting or attach an external ND filter to the lens ²
ND “ OFF ” flashes	Built-in ND filter not required	Turn off the ND filter
“ND” flashes in red	Incorrect setting of the built-in ND filter	Set the ND filter to an appropriate density

¹ Displayed only when using lenses with built-in ND filter.

² If you have no external ND filter available, use the **Tv** mode and set a faster shutter speed, or use the **Av** mode and set a small aperture value.



Depending on the scene, the color may change when turning the ND filter on/off. Setting a custom white balance may be effective in such case (68).

Selecting the Frame Rate

You can set the frame rate to 50i or 25F, regardless of the recording mode.

50i Mode

Records 50 interlaced fields per second, the same as standard-definition TV signals.

25F Mode

(HD) Records 25 frames per second according to HDV native 1080/25p specifications. For playback, the signal is converted to 50i but video output from the HDV/DV terminal will be 25p.

(SD) The picture captured by the camera at 25 frames per second is converted and recorded on the tape as 50i.

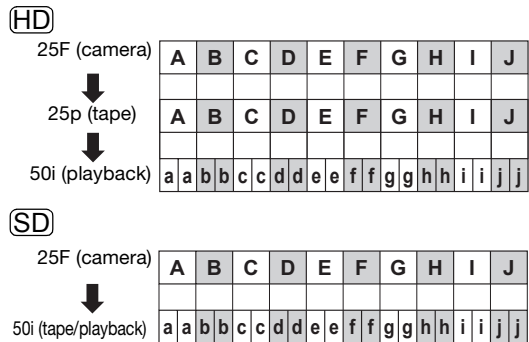

Set the FRAME RATE switch to the desired position.

- i: 50i Mode, F1 or F2: 25F Mode.
- The selected frame rate appears on-screen.

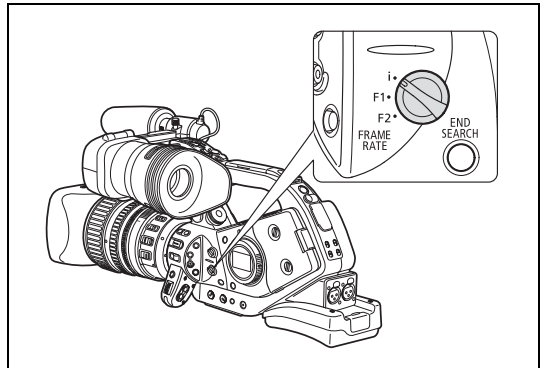

If the position of the FRAME RATE switch is changed while recording, the frame rate will not change immediately; it will change once you pause the recording.



Video recorded in 25F can only be played back with compatible devices and can only be edited with software that supports 25F. For software and hardware compatibility consult the relevant customer support center.

Setting the Time Code

You can select the running mode of the camcorder's time code. You can enter the initial value for the [FREE-RUN] and the [REC-RUN PS.] settings.

[REC-RUN]: The time code runs only when recording.

[REC-RUN PS.]: The time code runs only when recording, starting from a preset value.

[FREE-RUN]: The time code runs regardless of the operation of the camcorder.

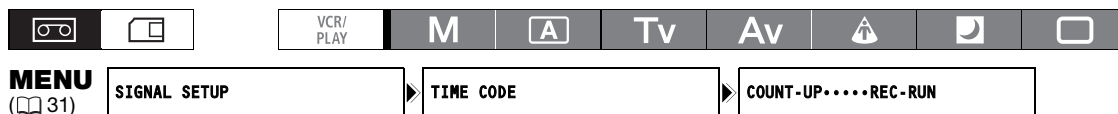

1. Open the menu and select [SIGNAL SETUP]. Select the [TIME CODE] submenu and then [COUNT-UP]. Select a setting option and close the menu.

[REC-RUN]: Close the menu.

[REC-RUN PS.], [FREE-RUN]: Continue the procedure to set the initial value.

2. Select [SET].

The hours display flashes.

3. Set the time code's initial value.

Turn the SELECT dial to set the value for the hours and press the SET button. Set the value for the minutes, seconds and frames in the same way.

4. Close the menu.



○ About the time code display

- [REC-RUN]: The time code will be displayed with an **R** next to it.
 - [REC-RUN PS.]: The time code will be displayed in blue with a **P** next to it.
 - [FREE-RUN]: The time code will be displayed in blue with an **F** next to it.
 - External Time Code: The time code will be displayed in blue with an **E** next to it.
 - Time Code Hold: The time code will be displayed with an **H** next to it.
 - Playback: No time code display.
- When you select [FREE-RUN], the time code starts to run the moment you press the MENU button in the middle of the setting, or when you press the SET button after setting the value for frames (F) in step 3.
 - To reset the time code to [00:00:00:00], select [RESET] in step 2.
 - When recording over existing scenes: When a time code discontinuity occurred near the recording start point, the time code at the point where the recording starts may be discontinuous as well.
 - As long as the built-in rechargeable lithium battery is charged, the free-run time code continues to run even if you disconnect all other power sources.

Synchronizing the Camcorder's Time Code

You can synchronize this camcorder's time code to an external time code generator. You can also include in the recording the user bit signal received from the TC-IN terminal (□ 52). The camcorder offers the following synchronization options.

Genlock

When a reference sync signal (analog blackburst or tri-level signal) is input through the GENLOCK terminal, the V and H phases of the camcorder's time code will automatically be synchronized to it.

Time Code IN

An external SMPTE-standard LTC timing signal received from the TC-IN terminal will be recorded as the time code on the tape. The user bit of the external timing signal can also be recorded on tape.

Time Code OUT

The camcorder's internal time code is sent out from the TC-OUT terminal as a standard LTC timing signal. When [SIGNAL SETUP] ► [SDI OUTPUT] is set to [ON(OSD)] or [ON], the time code signal will be output also through the HD/SD SDI terminal.

	CAMERA	VCR/PLAY	CAMERA · CARD	VCR/PLAY · CARD
Genlock	●	—	●	—
Time Code/User bit IN	●	—	—	—
Time Code OUT	●	●	—	—

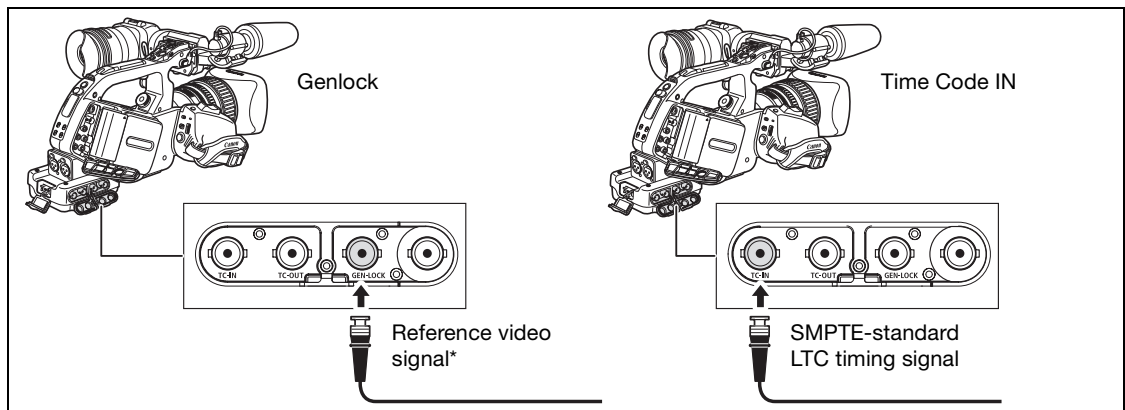

Connection Diagram



* As a reference video signal input you can use either an HD Y signal or a PAL composite video signal.



- While a time code signal is being received, the [COUNT-UP] setting of the camcorder will be ignored and the external time code's drop-frame bit will be used instead.
- The Genlock synchronization stabilizes after approx. 10 seconds. After that, the synchronization will be maintained even if you disconnect the cable from the GENLOCK terminal.

- When an external time code signal is received, the camcorder's own time code will be synchronized to it and the synchronization will be maintained even if you disconnect the cable from the TC-IN terminal. However, performing any of the following actions while the cable is not connected will cause the time code to lag slightly; the correct time code will be restored once you reconnect the cable.
 - Turning the camcorder off/on.
 - Changing the position of the **POWER** dial to or from VCR/PLAY.
 - Changing the position of the  (card/tape) switch.
 - Changing the position of the MODE SELECT or FRAME RATE switch.
- If the external time code signal is incorrect or there is no input signal, the internal time code (according to the [TIME CODE]/[COUNT-UP] settings) will be recorded on the tape instead.
- If the external Genlock signal is incorrect or there is no input signal, the external time code being recorded on tape may be incorrect.
- When the camcorder is set to HD standard, Genlock synchronization is possible even if the external Genlock signal is in SD standard. However, Genlock synchronization will not be possible if the external Genlock signal is in HD standard but the camcorder is set to SD standard.
- The phase difference between the external Genlock signal and the camcorder is initially set to 0; it can be adjusted within the range of approx. $\pm 0.4\text{H}$ (-1023 to +1023) with the [SIGNAL SETUP] ► [GENLCK ADJUST] setting ( 129).
- Genlock synchronization is not possible when the camcorder is set to HD standard and [SDI SPEC.] is set to [SD LOCKED].
- **About the Side Panel Indications**
 - "GENLOCK" will flash until the synchronization stabilizes and will stay on once the phase synchronization has stabilized.
 - "TC-IN" and "TC-OUT" indicate, respectively, that Time Code IN or Time Code OUT synchronization is available.
 - "EXT- LOCK" indicates that the camcorder has locked on to an external time code signal.

Setting the User Bit

The user bit display can be selected from the date or the time of recording, or an identification code consisting of 8 characters in the hexadecimal system that is useful for labeling tapes. There are sixteen possible characters: the numbers 0 to 9 and the letters A to F.

EXTRA If user bit information is being received along with an external time code, you can also record the external user bit on the tape.

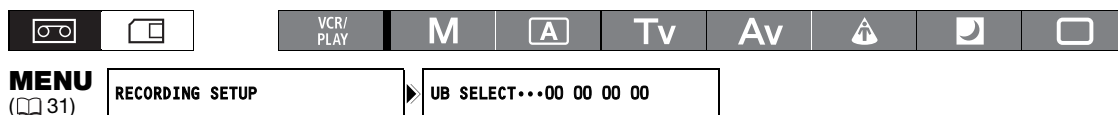

1. Open the menu and select [RECORDING SETUP]. Select [UB SELECT], select a setting option and press the SET button.

If you selected [00 00 00 00], the user bit set/reset options appear; continue with the procedure below. Otherwise, close the menu.

If you selected [00 00 00 00]:

2. Select [SET].

The first character of the user bit flashes.

3. Turn the SELECT dial to select a number or letter and press the SET button.

The next character of the user bit starts flashing. Set the rest of the user bit in the same way.

4. Close the menu.



- To reset the user bit to [00 00 00 00], select [CLEAR] in step 2.
- The user bit can be recorded when recording with the camcorder or from analog devices. The user bit set in the camcorder cannot be recorded when recording from digital devices (HDV or DV).

Displaying the User Bit

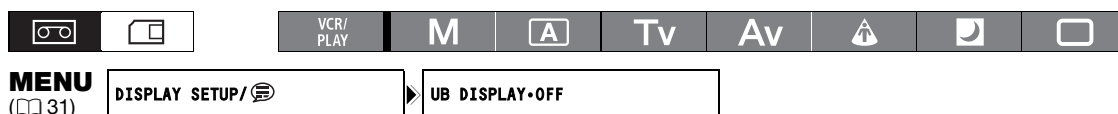

Open the menu and select [DISPLAY SETUP/⊗]. Select [UB DISPLAY], set it to [ON] and close the menu.

Recording an External User Bit



Open the menu and select [RECORDING SETUP]. Select [UB REC], select [EXT.USR-BIT] and close the menu.

Audio Recording

When recording on the tape in either HDV or DV standard, audio is recorded on two channels.

- (HDV)** The audio transfer rate is 384 kbps and the sampling frequency is 48 kHz.
- (DV)** You can record audio in 16-bit mode (sampling frequency 48 kHz), or 12-bit mode (sampling frequency 32 kHz).

- Audio is recorded on channels 1 and 2, leaving the other channels unused.
- Audio cannot be dubbed using this camcorder.
- Audio recorded with this camcorder is locked audio except for audio recorded from an analog input, or from a digital input if you select the Unlock mode.
- **XLR-113** While recording, the sampling frequency of the output signal from the HD/SD SDI terminal will be 48 kHz regardless of the audio input.

(SD) Selecting the DV Audio Mode

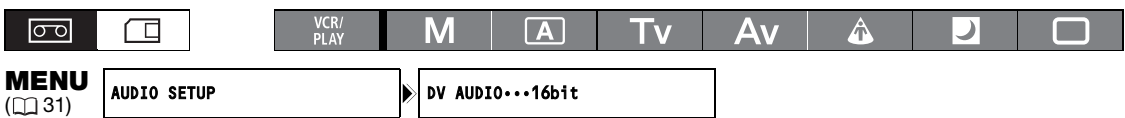

Open the menu and select **[AUDIO SETUP]**. Select **[DV AUDIO]**, select a setting option and close the menu.

Using the Wind Screen

With the supplied microphone (only), you can reduce the sound of wind recorded from the front microphone.

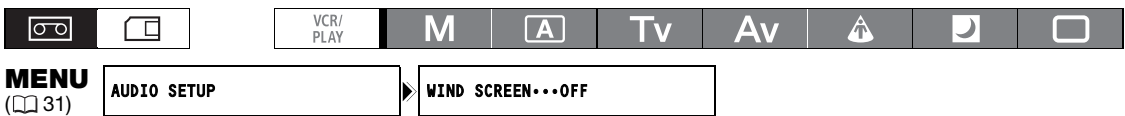

Open the menu and select **[AUDIO SETUP]**. Select **[WIND SCREEN]**, set it to **[ON]** and close the menu.

Selecting the Sensitivity of the Front Microphone

You can change the sensitivity of the front microphone to **[NORMAL]** or **[HIGH]** (+6 dB) to match the recording conditions.

[NORMAL]: To record audio under usual conditions.

[HIGH]: To record audio at a higher volume.

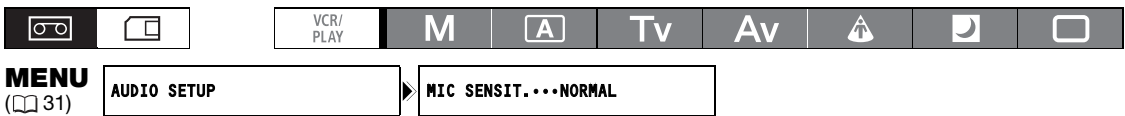

Open the menu and select **[AUDIO SETUP]**. Select **[MIC SENSIT.]**, select a setting option and close the menu.

Recording Audio

Select the audio input from FRONT (supplied microphone), XLR MIC (XLR terminals) or XLR LINE (XLR terminals). You can select the audio input independently for channel 1 and channel 2.



Using the Front Microphone

Set the INPUT SELECT switch to FRONT MIC.

- You can select the microphone setting with the STEREO/MONO switch on the microphone itself. In the MONO position, the same monaural audio signal will be recorded on channels 1 and 2.

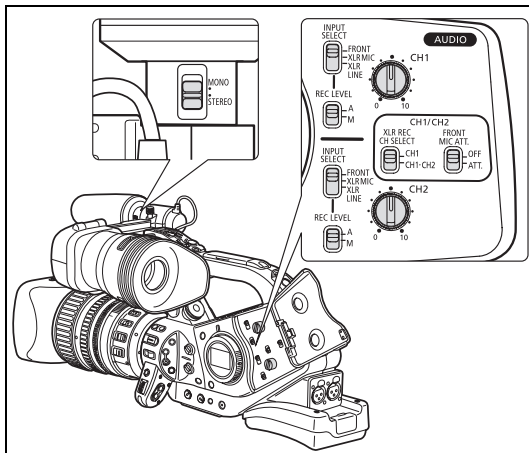

Using the XLR terminals

1. Connect a microphone to one of the XLR terminals.

- To supply a microphone with phantom power, set the corresponding **+48V** switch to ON. Make sure to connect the microphone first, before turning the phantom power on. Keep the microphone connected when turning off the phantom power.
- Use commercially available microphones with a cable no longer than 3 m.

2. Set the INPUT SELECT switch to XLR MIC or XLR LINE.

3. Set the XLR REC CH SELECT switch to CH1 or CH1·CH2.

4. If necessary, turn on the microphone attenuator (20 dB) by setting the corresponding **XLR MIC ATT.** switch to ATT.

The microphone attenuator will only be effective when the INPUT SELECT switch is set to XLR MIC.

5. If necessary, adjust the gain of the input signal. Open the menu and select [AUDIO SETUP]. Select [XLR 1 TRIM] or [XLR 2 TRIM], depending on the audio input you want to adjust. Select a setting option and close the menu.

The gain adjustment will only be effective when the INPUT SELECT switch is set to XLR MIC.

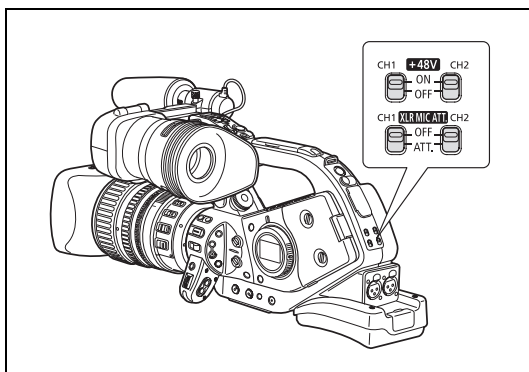

When connecting a microphone that does not support phantom power, make sure to set the **+48V** switch to OFF. Otherwise the microphone may be damaged.

Adjusting the Audio Recording Level

If the audio level is too high and the sound sounds distorted, activate the microphone attenuator (20 dB), by setting the FRONT MIC ATT. switch or the corresponding **XLR MIC ATT.** switch to ATT.



Hiding/Displaying the Audio Level Indicator



Open the menu and select **[DISPLAY SETUP/☰]**. Select **[AUDIO LEVEL]**, select a setting option and close the menu.

The audio level indicator can also be turned on/off with a custom key (31 75).

Automatic Audio Adjustment

Set the REC LEVEL switch to A.

- i** ○ When recording audio using the front microphone, you can change the microphone's sensitivity (31 53).
- When the INPUT SELECT switches for both channels are set to FRONT, if the REC LEVEL switch for CH1 is set to A, the automatic audio adjustment setting will automatically apply to CH2 as well.
- When the INPUT SELECT switches for both channels are set to XLR MIC or XLR LINE, you can select if the audio adjustment setting for CH2 will be linked to that of CH1 ([LINK]), or if the settings will be separated ([SEP]).

Open the menu and select **[AUDIO SETUP]**. Select **[XLR ALC LINK]**, select a setting option and close the menu.

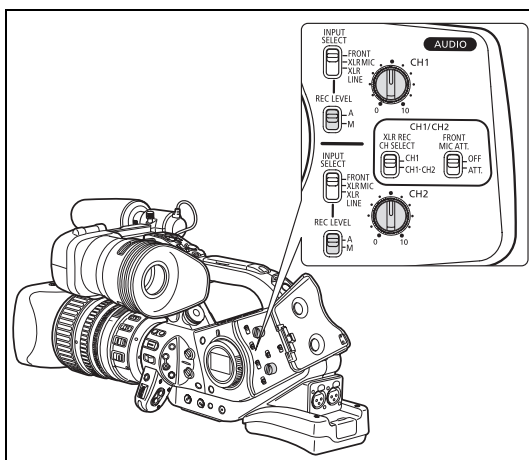

Manual Audio Adjustment

1. Set the REC LEVEL switch to M.
2. Turn the corresponding **AUDIO** dial (CH1 or CH2) to adjust each channel's audio level.

Adjust the audio recording level so that the audio level meter will go to the right of the **12** mark on the side panel's audio level meter (or the larger dot on the level meter displayed on the screen) only occasionally.

- i** ○ We recommend using headphones when adjusting the audio level. If the input level is too high, audio may become distorted even if the audio level indicator shows an appropriate level. Use commercially available headphones with a cable no longer than 3 m.

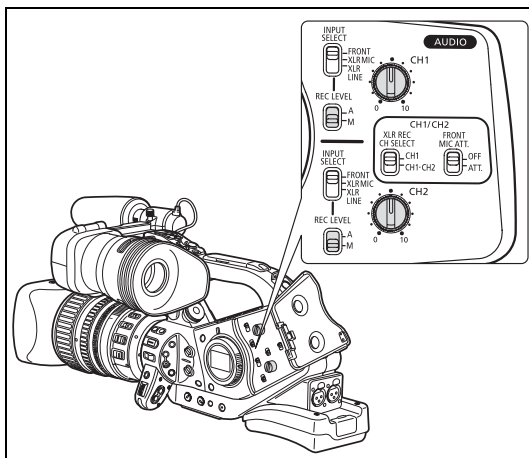

- You can select to synchronize the audio signal with the video signal by adding an equal amount of delay to the audio. Open the menu and select [AUDIO SETUP]. Select [MONITOR SEL.], set it to [LINE OUT] and close the menu. If you wish to monitor audio in real time, select [NORMAL] instead. With either setting, the audio and video signals recorded on the tape will be synchronized.
- You can activate the audio peak limiter to prevent audio distortions. When activated, the audio peak limiter will limit the amplitude of audio input signals when they exceed -4 dBFS. The audio peak limiter can be activated if at least one of the channels is set to manual audio adjustment. Open the menu and select [AUDIO SETUP]. Select [AUD.LIMITER], set it to [ON] and close the menu.
- When the INPUT SELECT switches for both channels are set to FRONT, if the REC LEVEL switch for CH1 is set to M, the audio level adjusted with the CH1 dial will automatically apply to CH2 as well.

XLH16 Embedded Audio

Embedded audio refers to the superimposing of the audio signal along with the video signal being output from the HD/SD SDI terminal.

[ON]: To embed the audio.

[ON(OSD)]: To embed the audio and on-screen displays.

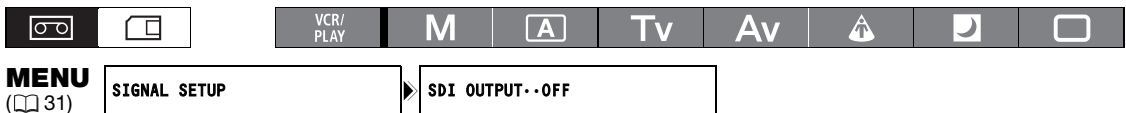

Open the menu and select [SIGNAL SETUP]. Select [SDI OUTPUT], select a setting option and close the menu.

CAMERA: The embedded audio output depends on the signal standard and the sampling frequency settings.

Signal standard	Sampling frequency	Locked/unlocked audio	Embedded audio output
HD	(48 kHz)	Locked	●
SD	32 kHz (12bit)	Locked	●*
	48 kHz (16bit)	Locked	●

VCR/PLAY: Cannot output embedded audio from a tape that was originally recorded with unlocked audio. **3/4** or **1/2** will appear on the screen.

Signal standard	Sampling frequency	Locked/unlocked audio	Embedded audio output
HD	(48 kHz)	Locked	●
SD	32 kHz (12bit)	Locked	●*
		Unlocked	—
	48 kHz (16bit)	Locked	●
		Unlocked	—

* The sampling rate will be 48 kHz.

When [SDI OUTPUT] is set to [ON(OSD)], will appear on the screen and on-screen displays will be included in the video signal output from the SDI terminal.

Image Stabilizer

(lenses with image stabilization function)

You can select to activate the image stabilizer or turn it off depending on the recording conditions.



To turn off the image stabilizer using the HD 20x L IS III lens:

Set the STABILIZER ON/OFF switch to OFF.

The image stabilizer cannot be turned off in Easy Recording mode.

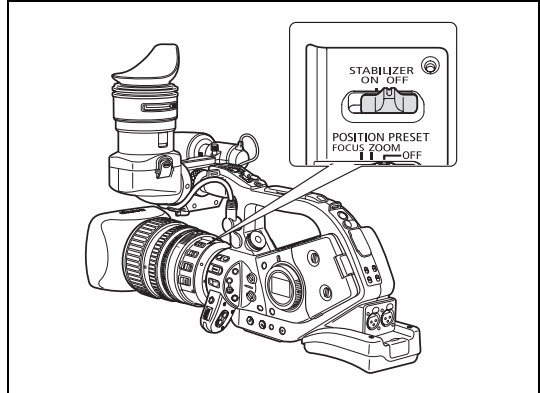

- We recommend turning off the image stabilizer when the camcorder is mounted on a tripod.
- The image stabilizer is designed to compensate for a normal degree of camcorder shake.
- The image stabilizer may not be effective when attaching an optional Extender.
- **CAMERA · CARD**: The image stabilizer will be activated while half-pressing the PHOTO button to lock the autofocus.

Using the Programmed AE Modes

Programmed auto exposure modes provide advanced automated recording techniques ensuring professional results in various shooting conditions.

M Manual (📖 61)

This mode offers the creative freedom of a complete range of manual controls. In Manual mode, you have the option to set the exposure at any combination of shutter speed and aperture levels.

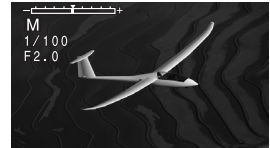

A Auto

Like the Easy Recording mode, the camcorder automatically controls camera adjustments allowing you to simply point and film. However, in Auto mode you have the option of adjusting the settings manually.



Tv Shutter-Priority (📖 63)

Use this mode to select the shutter speed. The camcorder automatically sets the appropriate aperture value.



Av Aperture-Priority (📖 64)

Use this mode to select the aperture value from F/1.6 to F/9.5 (or full iris close) and let the camcorder automatically set the appropriate shutter speed. This mode allows for the best control of depth of field.



Spotlight

The Spotlight mode automatically adjusts the exposure to effectively record images and/or subjects lit by a spotlight or other concentrated light source.



Night

This mode allows you to continue recording even when light levels begin to fall. The camcorder uses slower shutter speeds (1/3–1/500) to deliver proper exposure.

- Moving subjects may leave a trailing afterimage.
- Picture quality may not be as good as in other modes.
- White points may appear on the screen.
- Autofocus may not work as well as in other modes. In such case, adjust the focus manually.



☐ Easy Recording

The camcorder automatically controls the focus, shutter speed, aperture, gain, white balance, and AE Shift allowing you to simply point and film. This mode locks all of these features and options, making them fixed and unadjustable.



Selecting the Programmed AE Modes

Press the lock button and turn the **POWER** dial.

The symbol of the selected mode appears.

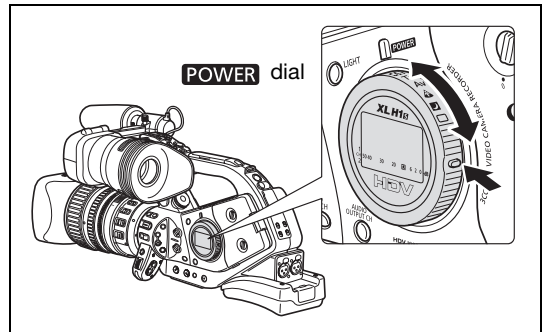

- Do not change the position of the **POWER** dial while recording as the brightness of the image may change abruptly.
- The ☐ Easy Recording, ⚠ Spotlight and 🌙 Night modes are all-automatic modes. In the **A** Auto, **Tv** Shutter-Priority, **Av** Aperture-Priority and **M** Manual modes you can change some settings manually according to the recording conditions.

Available controls/functions by programmed AE mode

	M	A	Tv	Av	⚠	🌙	☐
EXP. LOCK button	–		●			–	
PUSH AE button	●				–		
Iris ring ³	●	– ¹	– ¹	●		–	
SHUTTER buttons	●	– ¹	●	– ¹		–	
AE SHIFT dial	–		●			– (0)	
GAIN dial	●		●		– (0 dB)	– (auto)	
WHITE BALANCE dial	●			●			– (auto)
Custom preset adjustments	●			●			–
CUSTOM PRESET SELECT button	●			●			–
CUSTOM PRESET ON/OFF button	●			●			–
Skin detail	●			●			–
Clear scan	● ²	–	● ²		–		–
Frequency selection for clear scan	●	–	●		–		–

¹ Available during exposure lock.

² Available during clear scan.

³ Only lenses with manual iris ring.

Available lens functions by programmed AE mode¹

	<input type="checkbox"/>	All other modes
Focus ring		●
Zoom ring		●
Iris ring	See previous table	
Image stabilizer ²	– (ON)	●
ND filter		●
Focus mode selection	– (AF)	●
▶AF switch (Push-AF)	–	●

¹ HD 20x L IS III, HD 20x L IS II, HD 6x L, 20x L IS and 16x IS II lenses.

² Not available with the HD 6x L lens.

Recording in Manual Mode

You can set the exposure at any combination of shutter speed and aperture. The aperture value can be adjusted in 1/16 EV stops; however, the aperture value displayed on the screen will change only in 1/4 EV stops.

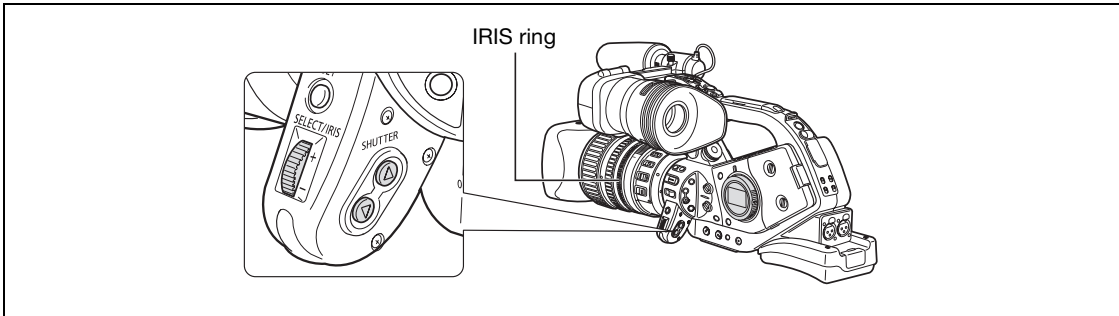

Available settings

Shutter speed	CAMERA	1/3*, 1/6, 1/12, 1/25, 1/50, 1/60, 1/75, 1/90, 1/100, 1/120, 1/150, 1/180, 1/210, 1/250, 1/300, 1/350, 1/400, 1/500, 1/600, 1/700, 1/800, 1/1000, 1/1200, 1/1400, 1/1600, 1/2000, 1/2400, 1/2800, 1/3200, 1/4000, 1/8000, 1/16000, CS (clear scan)
	CAMERA - CARD	1/3*, 1/6, 1/12, 1/25, 1/50, 1/60, 1/75, 1/90, 1/100, 1/120, 1/150, 1/180, 1/210, 1/250, 1/300, 1/350, 1/400, 1/500
Aperture (with the HD 20x L IS II or HD 20x L IS III lens)		F1.6, F1.8, F2.0, F2.2, F2.4, F2.6, F2.8, F3.2, F3.4, F3.7, F4.0, F4.4, F4.8, F5.2, F5.6, F6.2, F6.7, F7.3, F8.0, F8.7, F9.5, F10**, F11**, F12**, F14**, F15**, F16**, F17**, F19**, F21**, F22**, CLOSE**

* Only with the HD 20x L IS or HD 20x L IS III Lens.

** Can only be selected if the custom function [IRIS LIMIT] is set to [OFF].



1. Set the **POWER** dial to **M**.

- The exposure indicator appears. Use the exposure indicator as an estimate.
- The ▼ mark above the indicator indicates the standard exposure (calculated by the camcorder). The ■ mark of the indicator indicates the current exposure level within ± 2 EV stops of the standard exposure (beyond 2 stops, the marker will blink).

2. Select the aperture using the **IRIS** dial or the **iris ring** (only lenses with manual iris ring, like the **HD 20x L IS III** lens).

With the custom function [RINGS DIRECTION] (□ 100) you can change the direction of the adjustment when you turn the iris ring and IRIS dial (the setting is common to both).

3. Select the shutter speed with the **SHUTTER** ▲ or ▼ button.

With the custom function [OPER.DIRECTION] (□ 100) you can change the direction of the adjustment when you push the SHUTTER ▲ ▼ buttons.



- You can use the custom keys (□ 75) or the [SYSTEM SETUP/☺] ► [SHTR B.LOCK] setting (□ 132) to prevent the accidental operation of the SHUTTER buttons.
- With the custom function [IRIS LIMIT] (□ 100) you can activate the iris limit to prevent the aperture from closing below the diffraction limit of the lens. If the iris limit is not activated, aperture values that exceed the diffraction limit will appear in gray when selecting the aperture. Using aperture values displayed in gray will cause diffraction blur.
- When a lens without iris control function is used, the aperture value will not appear on the screen.
- With the custom function [LANC AE SHIFT] (□ 100), you can change the function of the AE SHIFT dial on the optional ZR-2000 Zoom Remote Controller and use it to change the aperture value.

Push AE

In **M** Manual mode you can use the Push AE function when you want the camcorder to re-establish optimal exposure settings by automatically adjusting the aperture and gain (if the GAIN dial is set to A).

Press the PUSH AE button and hold it pressed down.

- The camcorder will adjust the aperture value and gain to achieve optimal exposure (▼ mark above the exposure indicator).
- After you release the button, the aperture value and gain (if the GAIN dial is set to A) set by the camcorder will override the previous settings made in **M** Manual mode.

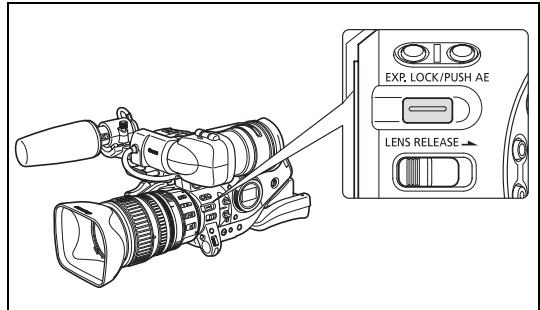

- The Push AE function is not available when no lens is attached to the camcorder, or if the aperture of the lens attached cannot be controlled from the camcorder.
- You can use the custom keys (📖 75) or the [SYSTEM SETUP/☺] ▶ [E.LCK B.LCK] setting to prevent the accidental operation of the PUSH AE button.

Recording in Shutter-Priority (Tv) Mode

Available shutter speeds when recording movies:

1/3*, 1/6, 1/12, 1/25, 1/50, 1/120, 1/250, 1/500, 1/1000, 1/2000, 1/4000, 1/8000, 1/16000, CS (clear scan)

Available shutter speeds when recording still images:

1/3*, 1/6, 1/12, 1/25, 1/50, 1/120, 1/250, 1/500

* Only with the HD 20x L IS II or HD 20x L IS III Lens.



1. Set the **POWER** dial to **Tv**.
2. Select the shutter speed with the **SHUTTER ▲ or ▼** button.

With the custom function [OPER.DIRECTION] (☐ 100) you can change the direction of the adjustment when you push the SHUTTER ▲▼ buttons.

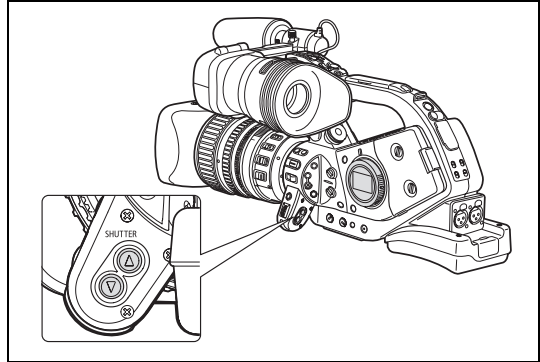

- Settings other than the shutter speed (aperture, etc.) are adjusted automatically.
- Using exposure lock to adjust the exposure manually will change the shutter speed, overriding the shutter speed selected in **Tv** mode.
- When the GAIN dial is set to A (automatic gain), the numeric value on the screen flashes if the selected shutter speed is not suitable for the recording conditions. In such case, readjust the shutter speed. If you are using an ND filter, turn it off first and readjust the shutter speed.
- Image quality may decrease to some extent when using slow shutter speeds.
- You can use the custom keys (☐ 75) or the [SYSTEM SETUP/☑] ▶ [SHTR B.LOCK] setting (☐ 132) to prevent the accidental operation of the SHUTTER buttons.

Recording in Aperture-Priority (Av) Mode

The aperture value can be adjusted in 1/16 EV stops; however, the aperture value displayed on the screen will change only in 1/4 EV stops.

Available aperture values (with the HD 20x L IS II or HD 20x L IS III lens)

F1.6, F1.8, F2.0, F2.2, F2.4, F2.6, F2.8, F3.2, F3.4, F3.7, F4.0, F4.4, F4.8, F5.2, F5.6, F6.2, F6.7, F7.3, F8.0, F8.7, F9.5, F10*, F11*, F12*, F14*, F15*, F16*, F17*, F19*, F21*, F22*, CLOSE*

* Can only be selected if the custom function [IRIS LIMIT] is set to [OFF].



1. Set the **POWER** dial to **Av**.

2. Select the aperture using the **IRIS** dial or the iris ring (only lenses with manual iris ring, like the HD 20x L IS III lens).

With the custom function [RINGS DIRECTION] (☞ 100) you can change the direction of the adjustment when you turn the iris ring and IRIS dial (the setting is common to both).

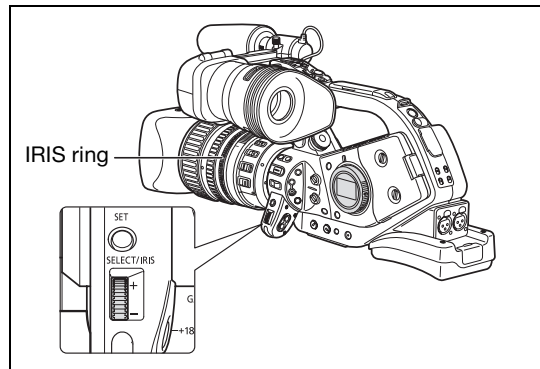

- Settings other than the aperture value (shutter speed, etc.) are adjusted automatically.
- Using exposure lock to adjust the exposure manually will change the aperture, overriding the value selected in **Av** mode.
- When the GAIN dial is set to A (automatic gain), the numeric value on the screen flashes when the selected aperture is not appropriate for the recording condition. In such case, readjust the aperture.
- When the built-in ND filter is activated, the picture may become dark when you set a high aperture value. In such case, turn off the ND Filter first and readjust the aperture.
- With the custom function [IRIS LIMIT] (☞ 100) you can activate the iris limit to prevent the aperture from closing below the diffraction limit of the lens. If the iris limit is not activated, aperture values that exceed the diffraction limit will appear in gray when selecting the aperture. Using aperture values displayed in gray will cause diffraction blur.
- When a lens without iris control function is used, the aperture value will not appear on the screen.
- With the custom function [LANC AE SHIFT] (☞ 100), you can change the function of the AE SHIFT dial on the optional ZR-2000 Zoom Remote Controller and use it to change the aperture value.

Adjusting the Exposure

Exposure Lock



1. Set the **POWER** dial to **A**, **Tv** or **Av**.

2. Press the **EXP. LOCK** button.

- The exposure indicator appears. Use the exposure indicator as an estimate.
- The ▼ mark above the indicator indicates the standard exposure (calculated by the camcorder). The ■ mark of the indicator indicates the current exposure level within ± 2 EV stops of the standard exposure (beyond 2 stops, the marker will blink).
- You can use the custom keys (75) or the [SYSTEM SETUP/☺] ► [E.LCK B.LCK] setting to prevent the accidental operation of the EXP. LOCK button.

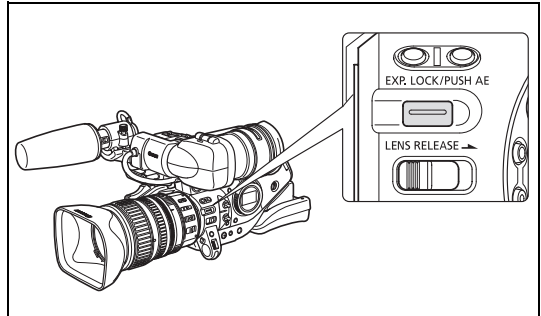

AE Shift

You can use the AE Shift control to manually override the automatic exposure system in order to darken or lighten the image. Select from 13 AE levels (+2.0, +1.5, +1.0, +0.75, +0.5, +0.25, ± 0 , -0.25, -0.5, -0.75, -1.0, -1.5, -2.0).



1. Set the **POWER** dial to **A**, **Tv** or **Av**.

2. Turn the **AE SHIFT** dial to adjust the level.

- “AE” and the selected shift level will be displayed on the screen.
- You can use the custom keys (75) or the [SYSTEM SETUP/☺] ► [AE D.LOCK] setting to prevent the accidental operation of the AE SHIFT dial.

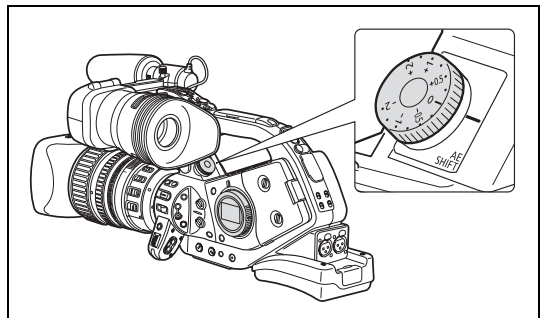

Gain

The gain control adjusts the level of the video signal generated depending on the lighting and shooting conditions. Select automatic gain control, one of the preset gain level ranging from -3 dB to +18 dB or fine-tune the gain level in 0.5 dB increments.

GAIN dial	Use
A	Automatic gain control.
-3	For the lowest noise recording for indoor, low light or low contrast scenes.
0	For lifelike night scenes or scenes under artificial lighting.
+3, +6, +12, +18	Increases the brightness in indoor or low-light scenes. Increases the depth of field.
0 – +18, +36	Gain fine tuning.



Selecting the Gain Level

1. Set the **POWER** dial to **A**, **Tv**, **Av** or **M**.
2. Push the **GAIN** dial so that it pops out.
3. Turn the **GAIN** dial to adjust the level.

When the dial is set to a position other than A (automatic gain control), the selected gain level appears.

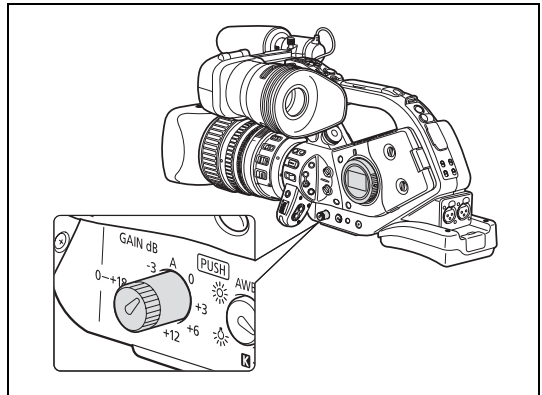

Gain Fine Tuning

1. Set the **POWER** dial to **A**, **Tv**, **Av** or **M**.

2. Set the **GAIN** dial to **0 – +18, +36**.

The gain level currently set will be displayed.

3. Press the **SET** button.

The gain level display will start flashing.

4. Turn the **SELECT** dial to set the desired gain level.

You can change the gain level in 0.5 dB increments within the range 0.0 to 18.0 dB. In **CAMERA** mode (only) you can also set the gain level to 36.0 dB.

5. Press the **SET** button again.

The gain level display stops flashing and stays on.



- When you select high gain levels, the picture may flicker slightly. The 36.0 dB gain level in particular, allows you to shoot video with a higher sensitivity but is more prone to the appearance of video noise and artifacts (white dots, vertical streaks or blocking).
- When the GAIN dial is set to A (automatic gain control) you can activate the gain limit to prevent the camcorder from setting a level higher than a preset limit between 3 dB and 15 dB. Open the menu and select [CAMERA SETUP]. Select [AGC LIMIT], set the maximum gain level and close the menu.

White Balance

The camcorder uses an electronic white balance process to calibrate the picture for accurate color display under different lighting conditions. In addition to the fully automated mode, white balance modes include an indoor mode, an outdoor mode, a color temperature setting and two user-defined custom preset values.

WHITE BALANCE dial	Use
AWB	Automatic adjustment of white balance.
☀️ (outdoor)	Bright sunlight (5,600 K).
💡 (indoor)	Incandescent light (3,200 K).
📏 (color temperature)	Setting depending on the hue of a specific lighting (2,000 - 15,000 K in 100 K increments).
Custom Preset A, B	Custom preset (3,200 - 5,600 K).



Selecting the White Balance Setting

1. Set the POWER dial to a recording program other than .
2. Push the WHITE BALANCE dial so that it pops out.
3. Set the WHITE BALANCE dial to the desired white balance setting.

You can fine-tune the preset ☀️/💡 settings. Press the WHITE BALANCE button so the preset icon and the neutral value ±0 start flashing. Adjust the white balance with the SELECT dial to a value between -9 and +9 and press the WHITE BALANCE button again.

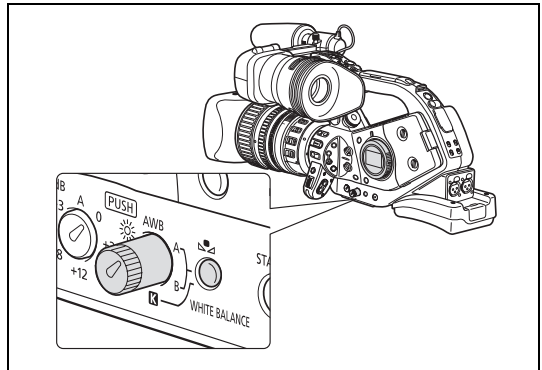

Recording

Setting the Color Temperature

1. Set the POWER dial to a recording program other than .
2. Set the WHITE BALANCE dial to .
- The color temperature currently set will be displayed.
3. Press the WHITE BALANCE button.
- The color temperature display will start flashing.
4. Turn the SELECT dial to set the desired color temperature.
5. Press the WHITE BALANCE button again.
- The color temperature display stops flashing and stays on.

Setting a Custom White Balance



1. Set the **POWER** dial to a recording program other than .
2. Press the **WHITE BALANCE** dial so that it pops out.
3. Set the **WHITE BALANCE** dial to one of the custom preset positions, **A** or **B**.
4. Point the camcorder at a white object and zoom in until it fills the whole screen.

Keep the camcorder zoomed at the white object until step 5 is completed.

5. Press the **WHITE BALANCE**  button.

 and the corresponding letter will stop flashing and stay on when the setting is completed.



- When you set the custom white balance: Very rarely and depending on the light source,  may keep flashing. The result will still be better than with the AWB setting.
- As long as the built-in rechargeable lithium battery is charged, the camcorder retains the custom white balance setting even if you turn it off.
- The following custom preset settings take precedence, and will override the white balance set with the procedure above: The color matrix [CMX] setting, the 3 R/G/B gain settings, and the 6 R/G/B matrix settings ( 98).
- The custom white balance may provide better results in the following cases:
 - Changing lighting conditions
 - Close-ups
 - Subjects in a single color (sky, sea or forest)
 - Under mercury lamps or certain types of fluorescent lights
- Perform the custom white balance setting procedure in a sufficiently well lit place.
- Readjust the custom white balance if you turn the ND filter on/off (lenses with a built-in ND filter) or when the light source has changed.

Recording with a Custom White Balance Previously Set

1. Set the **POWER** dial to a recording program other than .
2. Turn the **WHITE BALANCE** dial to the desired custom preset, **A** or **B**.

The custom white balance set in advance is activated.

Zebra Pattern

This camcorder has a zebra pattern feature that shows black and white diagonal stripes over the areas that are overexposed. The zebra pattern is only displayed on the screen and will not affect your recordings. The zebra pattern will not be displayed while the Peaking function is activated (📖 44).

Available zebra pattern settings: 70 IRE, 75 IRE, 80 IRE, 85 IRE, 90 IRE, 95 IRE, and 100 IRE.



Selecting the Zebra Pattern Level

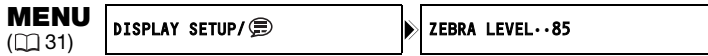

Open the menu and select [DISPLAY SETUP/🗨️]. Select [ZEBRA LEVEL], select a setting option and close the menu.

Activating the Zebra Pattern

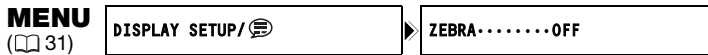

Open the menu and select [DISPLAY SETUP/🗨️]. Select [ZEBRA], set it to [ON] and close the menu.

Color Correction

With the color correction function you can set the camcorder to detect the characteristics of a certain color or pattern (color phase, chroma, area and Y level) and correct them automatically when recording. You can set the color correction for up to two different colors (A and B).

When determining the color to be corrected, targeted areas will be identified on the screen by zebra pattern alternating with the normal picture. On a connected monitor or computer, targeted areas will be identified by white areas alternating with the normal picture.



Determining the Color to be Corrected

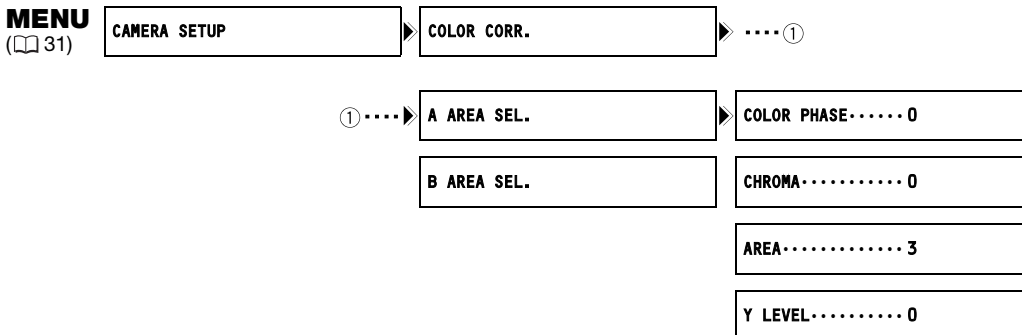

1. Open the menu and select **[CAMERA SETUP]**. Select the **[COLOR CORR.]** submenu and then select **[A AREA SEL.]** or **[B AREA SEL.]**.

2. Select each setting option, adjust the levels as necessary and close the menu.

[COLOR PHASE]: Select the basic color phase (0-15) of the color to be detected. Use the following values as an approximate reference: 0=purple, 3=red, 6=orange, 9=green, 12=blue.

[CHROMA]: Adjust the color saturation for the color to be detected. 13 levels (-6 to 6) are available; set higher levels to detect areas with richer colors.

[AREA]: Adjust the color range for the color to be detected. 4 levels (1 to 4) are available; set higher levels to detect a wider color range.

[Y LEVEL]: Adjust the brightness for the color to be detected. 13 levels (-6 to 6) are available; set higher levels to detect brighter areas.

Adjusting the Color Correction

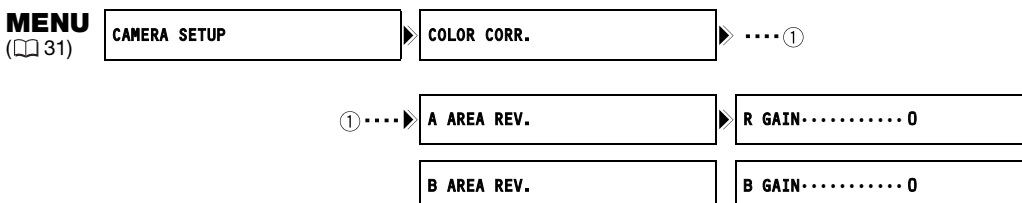

1. Open the menu and select **[CAMERA SETUP]**. Select the **[COLOR CORR.]** submenu and then select **[A AREA REV.]** or **[B AREA REV.]**.

2. Select the color gain options, adjust the levels as necessary and close the menu.

[R GAIN]: Adjust the red gain of the detected area. 13 levels (-6 to 6) are available; set [+] values to increase red tones or [-] values to increase cyan tones.

[B GAIN]: Adjust the blue gain of the detected area. 13 levels (-6 to 6) are available; set [+] values to increase blue tones or [-] values to increase yellow tones.

Activating the Color Correction



1. Open the menu and select **[CAMERA SETUP]** and select the **[COLOR CORR.]** submenu.
2. Select **[CORRECT]**, select a correction mode and close the menu.
 - You can correct only the predefined A area, only the predefined B area or both.
 -  appears.

Skin Detail Function

With the skin detail function you can set the camcorder to detect the characteristics of a certain color or tone. Detail in the targeted areas will be softened in order to conceal skin imperfections. Targeted areas will be identified on the screen by a zebra pattern alternating with the normal picture. On a connected monitor or computer, targeted areas will be identified by white areas alternating with the normal picture. You can adjust the hue, chroma, area and Y level as required, to determine the areas that will be detected as skin areas.



Determining the Tone to be Detected as Skin Area

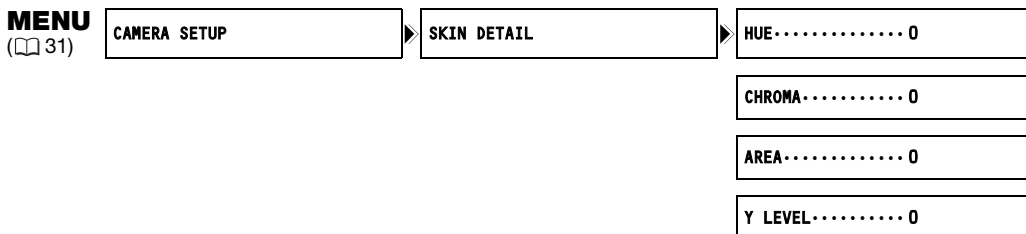

1. Open the menu, select [CAMERA SETUP] and then select the [SKIN DETAIL] submenu.
2. Select each setting option, adjust the levels as necessary and close the menu.
 - [HUE]: Adjust the hue for detection of the skin area. 13 levels (-6 to 6) are available; set [+] values to detect hues closer to red or [-] values to detect hues closer to green.
 - [CHROMA]: Adjust the color saturation for detection of the skin area. 13 levels (-6 to 6) are available; set higher levels to detect areas with richer colors.
 - [AREA]: Adjust the color range for detection of the skin area. 13 levels (-6 to 6) are available; set higher levels to detect a wider color range.
 - [Y LEVEL]: Adjust the brightness for detection of the skin area. 13 levels (-6 to 6) are available; set higher levels to detect brighter areas.

Activating the Skin Detail Function



1. Open the menu and select [CAMERA SETUP]. Select the [SKIN DETAIL] submenu and then select [EFFECT LEVEL].
2. Select a setting option and close the menu.
 - You can select the strength of the effect from low, middle or high.
 -  appears.

S-NR Selective Noise Reduction

With the selective noise reduction function you can set the camcorder to detect the characteristics of a certain color or tone and automatically reduce noise in the targeted areas. This is particularly useful for chroma keying, as targeting the selective noise reduction to the color of the background green or blue screen will result in a smoother composite picture.

Targeted areas will be identified on the screen by a zebra pattern alternating with the normal picture. On a connected monitor or computer, targeted areas will be identified by white areas alternating with the normal picture.



Determining the Area to be Corrected

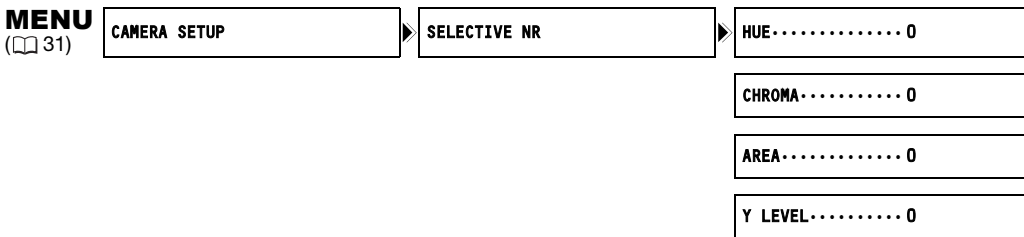

1. Open the menu, select [CAMERA SETUP] and then select the [SELECTIVE NR] submenu.
2. Select each setting option, adjust the levels as necessary and close the menu.
 - [HUE]: Select the base hue (-6 to 6) of the color to be detected. Use the following values as an approximate reference: -6=blue-violet, 0=cyan, 6=yellowish green.
 - [CHROMA]: Adjust the color saturation for the color to be detected. 13 levels (-6 to 6) are available; set higher levels to detect areas with richer colors.
 - [AREA]: Adjust the color range for the color to be detected. 13 levels (-6 to 6) are available; set higher levels to detect a wider color range.
 - [Y LEVEL]: Adjust the brightness for the color to be detected. 13 levels (-6 to 6) are available; set higher levels to detect brighter areas.

Activating the Selective Noise Reduction

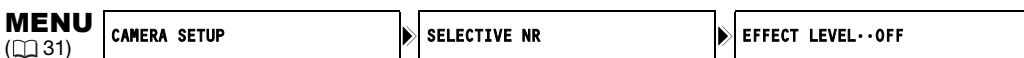

1. Open the menu and select [CAMERA SETUP]. Select the [SELECTIVE NR] submenu and then select [EFFECT LEVEL].
2. Select a setting option and close the menu.
 - You can select the strength of the effect from low, middle or high.
 - S-NR appears.

Clear Scan

This feature allows you to record a computer's CRT screen or other equipment without displaying black band or flicker on the screen. You can adjust the frequency from 50.2 Hz to 200.3 Hz.

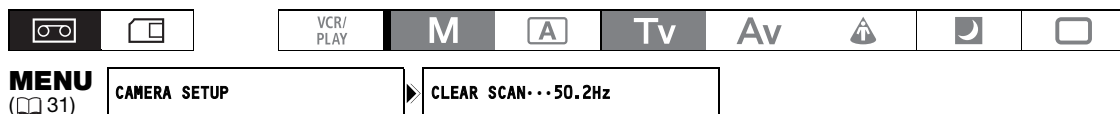

1. Set the **POWER** dial to **Tv** or **M**.
 2. Repeatedly press the **SHUTTER ▲** button to set the shutter speed to "CS".
 3. Open the menu and select [**CAMERA SETUP**]. Select [**CLEAR SCAN**], adjust the frequency and close the menu.
- Adjust the frequency so that the black band does not appear.

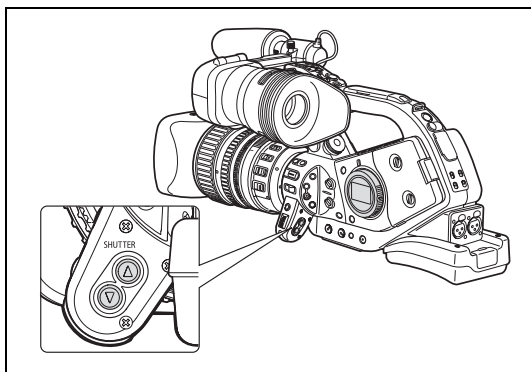

Custom Keys

You can assign frequently used functions to the custom keys. The custom keys can have different functions assigned to them in each of the operating modes.

Default settings:

	CAMERA	VCR/PLAY	CAMERA · CARD	VCR/PLAY · CARD
CUSTOM KEY 1	TIME CODE	TV SCREEN	ZEBRA	TV SCREEN
CUSTOM KEY 2	INDEX WRITE	DATA CODE	TV SCREEN	EVF BW MODE

To check the current custom key settings:

In a recording mode: Open the menu and select [DISPLAY SETUP/☰]. Select [GUIDE INFO], set it to [CUSTOM KEYS] and close the menu.

In a playback mode: Open the menu and select [DISPLAY SETUP/☰]. Select [CUSTOM KEY], set it to [ON] and close the menu.

The following functions can be assigned to the custom keys:

<p>CAMERA</p> <p>Time code Index write ² Zebra pattern VCR stop ² TV screen Time code hold ² Audio level Viewfinder's B&W mode MAGN. button lock</p>	<p>SHUTTER button lock AE SHIFT dial lock EXP. LOCK button lock CP backward key ^{1,2} Flange back adjustment Flip EVF ² SDI output ³ Focus limit</p>	<p>VCR/PLAY</p> <p>Time code TV screen Data code Audio level Time code hold ² Viewfinder's B&W mode SDI output ³</p>
<p>CAMERA · CARD</p> <p>Zebra pattern TV screen Viewfinder's B&W mode MAGN. button lock SHUTTER button lock AE SHIFT dial lock</p>	<p>EXP. LOCK button lock CP backward key ^{1,2} Flange back adjustment Flip EVF ² SDI output ³ Focus limit</p>	<p>VCR/PLAY · CARD</p> <p>TV screen Viewfinder's B&W mode SDI output ³</p>

¹ Can only be assigned to Custom Key 2.

² This function can only be operated with a custom key. (Index write can also be operated with the wireless controller.)

³ **XL-H1S** only.

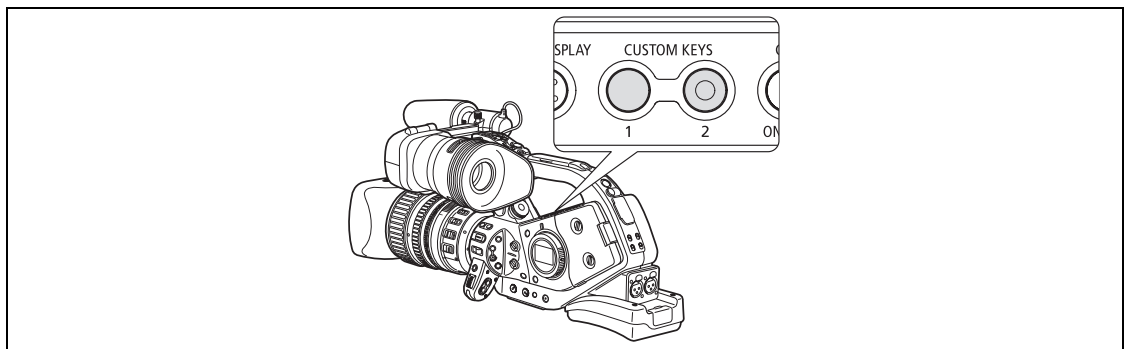

Changing the Custom Keys Setting

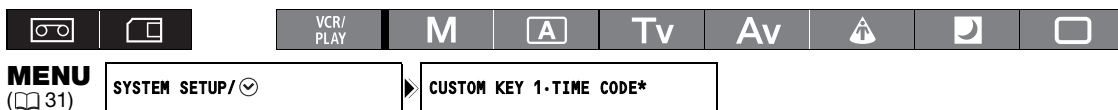

* Default value in **CAMERA** mode.

Open the menu and select **[SYSTEM SETUP/☑]**. Select **[CUSTOM KEY 1]** or **[CUSTOM KEY 2]**, select the function you wish to assign to the custom key and close the menu.

When you do not wish to use the custom keys, select **[(NONE)]**.

Activating the Functions with the Custom Key

[TIME CODE] Time Code (31 49) **CAMERA** **VCR/PLAY**

Press the **CUSTOM KEY (1 or 2)** button.

The time code setting menu appears.

[INDEX WRITE] Index Write **CAMERA**

You can add an index signal to your recording for easy search in **VCR/PLAY** mode (31 112).

Press the **CUSTOM KEY (1 or 2)** button.

- **IX** will appear while the index signal is being recorded (approx. 6.5 seconds).
- When the camcorder is in record pause mode, the index signal will be written when you start recording.
- An index signal cannot be added or erased later.

[ZEBRA] Zebra Pattern (31 69) **CAMERA** **CAMERA·CARD**

Press the **CUSTOM KEY (1 or 2)** button.

The zebra pattern is activated. Press the button again to cancel it.

[VCR STOP] VCR Stop (31 35) **CAMERA**

When the camcorder is in record pause mode, you can turn off the recorder section. Even if **[SYSTEM SETUP/☑]** **[POWER SAVE]** is set to **[OFF]**, you can take your time adjusting the camera settings, while the recorder section of the camcorder is powered off so you do not need to worry about the tape or the video heads.

VCR Stop can only be operated with the custom keys.

Press the **CUSTOM KEY (1 or 2)** button.

The VCR Stop mode is activated. Press the button again to return to record pause mode. You can also start recording by pressing the Start/Stop button directly in VCR Stop mode.

[TV SCREEN] TV Screen **CAMERA** **VCR/PLAY** **CAMERA·CARD** **VCR/PLAY·CARD**

You can show the camcorder's displays on a connected external monitor or TV.

Press the **CUSTOM KEY (1 or 2)** button.

[TC HOLD] Time Code Hold **CAMERA** **VCR/PLAY**

You can press the custom key button to freeze the display of the time code. The time code will continue running normally even while the time code display is on hold.

Time code hold can only be operated with the custom keys.

Press the CUSTOM KEY (1 or 2) button.

- Pressing the custom key button again will reactivate the normal display of the time code.
- While on hold, the time code will be displayed with an **H** next to it and “HOLD” will appear on the side panel.
- The time code being output from the TC-OUT*, HD/SD SDI*, **L** (LANC) and HDV/DV terminals will not be put on hold. The time code superimposed on the video signal output from the COMPONENT OUT, VIDEO IN/OUT and **S** IN/OUT (S-Video) terminals will be put on hold. (* **EXTRA** only.)
- The time code hold will be canceled when you turn the camcorder on/off, change the operating mode between recording and playback or change the position of the **C**/**T** (card/tape) switch.

[AUDIO LEVEL] Audio Level Indicator **CAMERA** **VCR/PLAY****Press the CUSTOM KEY (1 or 2) button.**

The audio level indicator appears. Press the button again to hide the audio level indicator.

[EVF BW MODE] Viewfinder's B&W mode**CAMERA** **VCR/PLAY** **CAMERA · CARD** **VCR/PLAY · CARD****Press the CUSTOM KEY (1 or 2) button.**

The image on the screen will be shown in black & white (on-screen displays and indicators will still be displayed in color). Press the button again to return to color display.

[MAGN.B.LOCK] MAGN. Button Lock **CAMERA** **CAMERA · CARD****Press the CUSTOM KEY (1 or 2) button.**

Pressing the button will lock the EVF MAGNIFYING button to prevent its accidental operation. Press the custom key button again to reactivate the EVF MAGNIFYING button.

[SHTR B.LOCK] SHUTTER Button Lock **CAMERA** **CAMERA · CARD****Press the CUSTOM KEY (1 or 2) button.**

Pressing the button will lock the SHUTTER buttons to prevent their accidental operation. Press the custom key button again to reactivate the SHUTTER buttons.

[AE D.LOCK] AE SHIFT Dial Lock **CAMERA** **CAMERA · CARD****Press the CUSTOM KEY (1 or 2) button.**

Pressing the button will lock the AE SHIFT dial to prevent its accidental operation. Press the custom key button again to reactivate the AE SHIFT dial.

[E.LCK B.LCK] EXP. LOCK Button Lock **CAMERA** **CAMERA · CARD****Press the CUSTOM KEY (1 or 2) button.**

Pressing the button will lock the EXP. LOCK button to prevent its accidental operation. Press the custom key button again to reactivate the EXP. LOCK button.

[CP BKWD KEY] Custom Preset Backward Key **CAMERA** **CAMERA · CARD**

Press the CUSTOM KEY 2 button.

Usually, pressing the CUSTOM PRESET SELECT button will cycle forwards to the following custom preset file. Pressing the custom key button instead will cycle backwards to the preceding custom preset file. CP backward key can only be operated with the custom keys.

[FB] Flange Back Adjustment **CAMERA** **CAMERA · CARD**

Press the CUSTOM KEY (1 or 2) button.

The flange back adjustment menu appears. (Will have no effect if flange back adjustment is not available with the lens attached.)

[FLIP EVF] Flip EVF **CAMERA** **CAMERA · CARD**

Press the CUSTOM KEY (1 or 2) button.

Activating the function will reverse the displayed image both upside/down and right/left. This affects only the display, and the video signal being output from all terminals will not change.

- When using XL lenses designed for HDV recording, the Flip EVF function will be deactivated while displaying the menu screens.
- Flip EVF can only be operated with the custom keys.

XLH13 [SDI OUTPUT] SDI Output **CAMERA** **VCR/PLAY** **CAMERA · CARD** **VCR/PLAY · CARD**

Press the CUSTOM KEY (1 or 2) button.

The SDI output setup menu appears.

[FOCUS LIMIT] Focus Limit (📖 46) **CAMERA** **CAMERA · CARD**

Press the CUSTOM KEY (1 or 2) button.

The focus limit is activated. Press the button again to cancel it.

[DATA CODE] Data Code (📖 113) **VCR/PLAY**

Press the CUSTOM KEY (1 or 2) button.

The data code appears. Press the button again to hide the data code.

Color Bars/Audio Reference Signal





You can generate and record color bars signals and a 1 kHz audio reference signal.

With the customized functions (☐ 100) you can choose between EBU ([TYPE 1]) and SMPTE color bars ([TYPE 2]) and you can also select the strength of the audio signal (-12 dB, -18 dB, or -20 dB).



1. Select the standard of the color bars signal [COLOR BARS] and the strength of the audio reference signal [1kHz TONE] with the customized functions (☐ 100).

2. Press the BARS/FADE SELECT button to display the  (color bars) icon.

- Repeatedly pressing the button will cycle through the options in the following order: , , , no display.
-  starts flashing.

3. Press the BARS/FADE ON/OFF button.

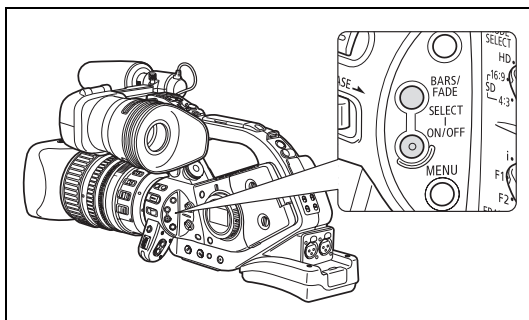

- The color bars appear and the audio reference signal is emitted (if activated). Press the Start/Stop button to record the signal.
- If you set the custom function [1kHz TONE] to [OFF], the current audio input (microphone, line in, etc.) will be recorded as the audio signal.





Faders

You can choose to fade to/from white or to/from black.



1. While recording or in record pause mode, press the BARS/FADE SELECT button to display the  (white fader) or  (black fader) icon.

- Repeatedly pressing the button will cycle through the options in the following order: , , , no display.
- The icon of the selected fader type starts flashing.

2. Press the BARS/FADE ON/OFF button.

The icon stops flashing.

3. Press the Start/Stop button.

- In record pause: the recording will fade in and start. While recording: the recording will fade out and stop.
- After the fade-in/out the icon will start flashing again. To activate the fader again, press the BARS/FADE ON/OFF button (step 2).

Video Signal Output Standards

The standard of the video signal output from the HD/SD SDI (**XLH13** only), COMPONENT OUT and HDV/DV terminals depends on the standard used for recording (or the standard of the recording on the tape being played back) and on various menu settings. Video output from the VIDEO OUT or  IN/OUT (S-Video) terminal will always be in 576/50i standard.

Standard of Video Output while Recording

XLH13 While recording in high definition, video output from the HD/SD SDI terminal will be an uncompressed HD, YPbPr signal. You can down-convert the video output with the respective menu settings.

Recording standard and frame rate	HD/SD SDI terminal ¹		COMPONENT OUT terminal		HDV/DV terminal
	Unchanged	Down-converted ^{2, 5, 6}	Unchanged	Down-converted ^{3, 5}	
HD 50i	1080/50i	576/50i	1080/50i	576/50i	1080/50i
HD 25F	1080/50i	576/50i ⁸	1080/50i	576/50i ⁸	1080/25p

Standard of Video Output during Playback

XLH13 When playing back a tape recorded in HDV standard, video output from the HD/SD SDI terminal will be a signal modified from the HDV video. You can down-convert the video output with the respective menu settings.

Standard of the tape	[LETTERBOX] setting	HD/SD SDI terminal ¹		COMPONENT OUT terminal		HDV/DV terminal	
		Unchanged	Down-converted ^{2, 5}	Unchanged	Down-Converted ^{3, 5}	Unchanged	Down-Converted ^{4, 7}
HDV 1080/50i	[OFF]	1080/50i	576/50i	1080/50i	576/50i	1080/50i	576/50i
	[ON]	576/50i		576/50i			
HDV 1080/25p	[OFF]	1080/50i ⁸	576/50i	1080/50i ⁸	576/50i	1080/25p	576/50i
	[ON]	576/50i ⁸		576/50i ⁸			

¹ **XLH13** only.

² [SIGNAL SETUP] ▶ [SDI SPEC.] set to [SD LOCKED].

³ [SIGNAL SETUP] ▶ [COMP.OUT] set to [576i].

⁴ [SIGNAL SETUP] ▶ [HD DOWN-CONV] set to [ON].

⁵ 16:9 picture is horizontally squeezed to a 4:3 aspect ratio.

⁶ On-screen displays will not be embedded in the video output even if [SIGNAL SETUP] ▶ [SDI OUTPUT] is set to [ON(OSD)].

⁷ On-screen displays will not be embedded in the video output even if [DISPLAY SETUP/] ▶ [TV SCREEN] is set to [ON].

⁸ Converted to 50i.

Connecting to a Monitor/TV

The different recording modes and the corresponding output terminals are given in the table below:

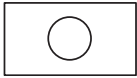
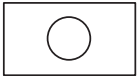
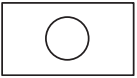
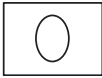
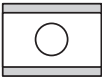
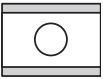
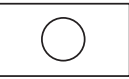
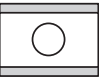
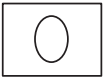
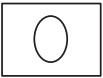
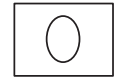
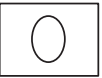
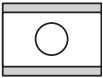
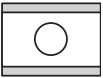
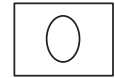
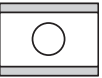
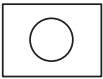
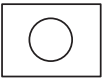
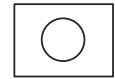
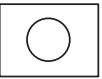
		HD/SD SDI Terminal*	COMPONENT OUT Terminal	HDV/DV Terminal	VIDEO and [®] Terminals
HD	[LETTERBOX] set to [OFF]	1920x1080 	D3 (1440x1080) 	MPEG TS 	
	[LETTERBOX] set to [ON]	SD SDI 	D1 (SD) 	MPEG TS 	
SD 16:9	[LETTERBOX] set to [OFF]	640x480 	D1 (SD) 	DV (SD) 	
	[LETTERBOX] set to [ON]	SD SDI 	D1 (SD) 	DV (SD) 	
SD 4:3		640x480 	D1 (SD) Normal 	DV (SD) 	

* **EX-LHS** only.

Displaying the Viewfinder's Screen on an External Monitor

The screen of an external monitor or viewfinder connected to the EVF2 socket will show the exact same picture as displayed on the camcorder's viewfinder screen. Use the supplied external monitor cable to connect to a monitor or TV equipped with component video inputs.

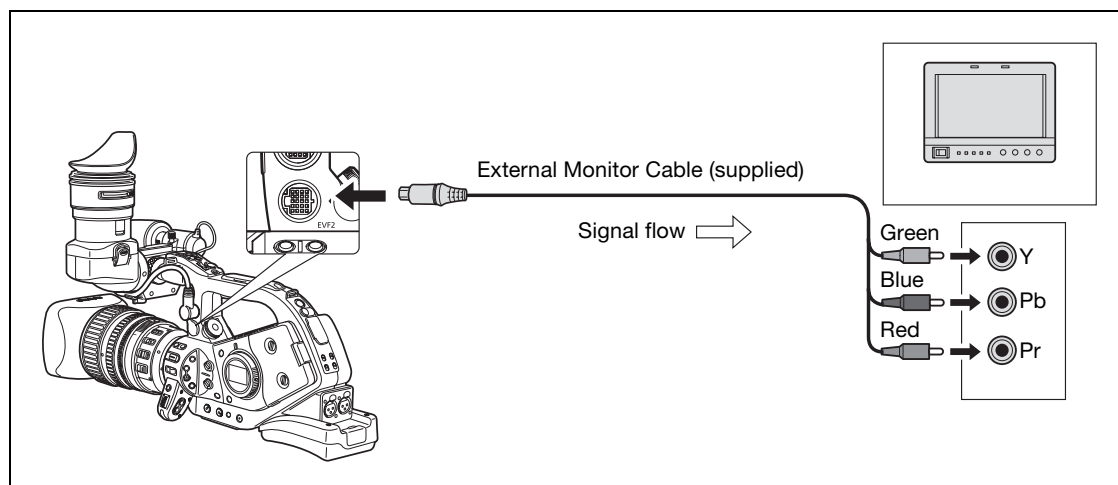

Connection to a High Definition Monitor or HDTV

1 **XLH13** Using the HD/SD SDI Terminal

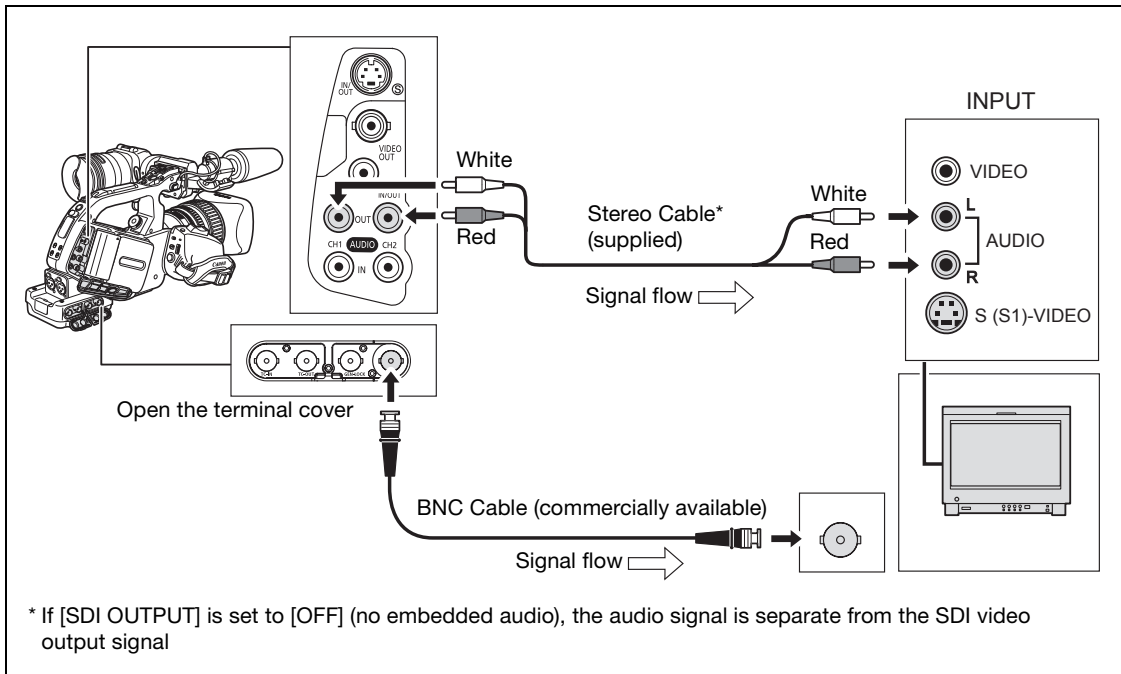

Activate the HD/SD SDI output and select the appropriate video output option (HD or SD).

1. Set the **POWER** dial to VCR/PLAY .
2. Open the menu and select [SIGNAL SETUP]. Select [SDI OUTPUT] and set it to [ON] or [ON(OSD)].
3. From the same [SIGNAL SETUP] submenu select [SDI SPEC.]. Select [AUTO] or [SD LOCKED] to match the video output you wish to use.
4. Close the menu.



When [SDI OUTPUT] is set to [ON(OSD)], **SDI** will appear on the screen and on-screen displays will be included in the video signal output from the SDI terminal.



When [SDI OUTPUT] is set to [ON(OSD)]:

- The on-screen displays included in the video output signal are determined by the display level selected with the EVF DISPLAY button (□ 37). Markers (safety zone guide, level/grid markers, etc.) are never included in the video signal output.
- The [SIGNAL SETUP] ▶ [COMP.OUT] setting is not available.

2 Using the COMPONENT OUT Terminal

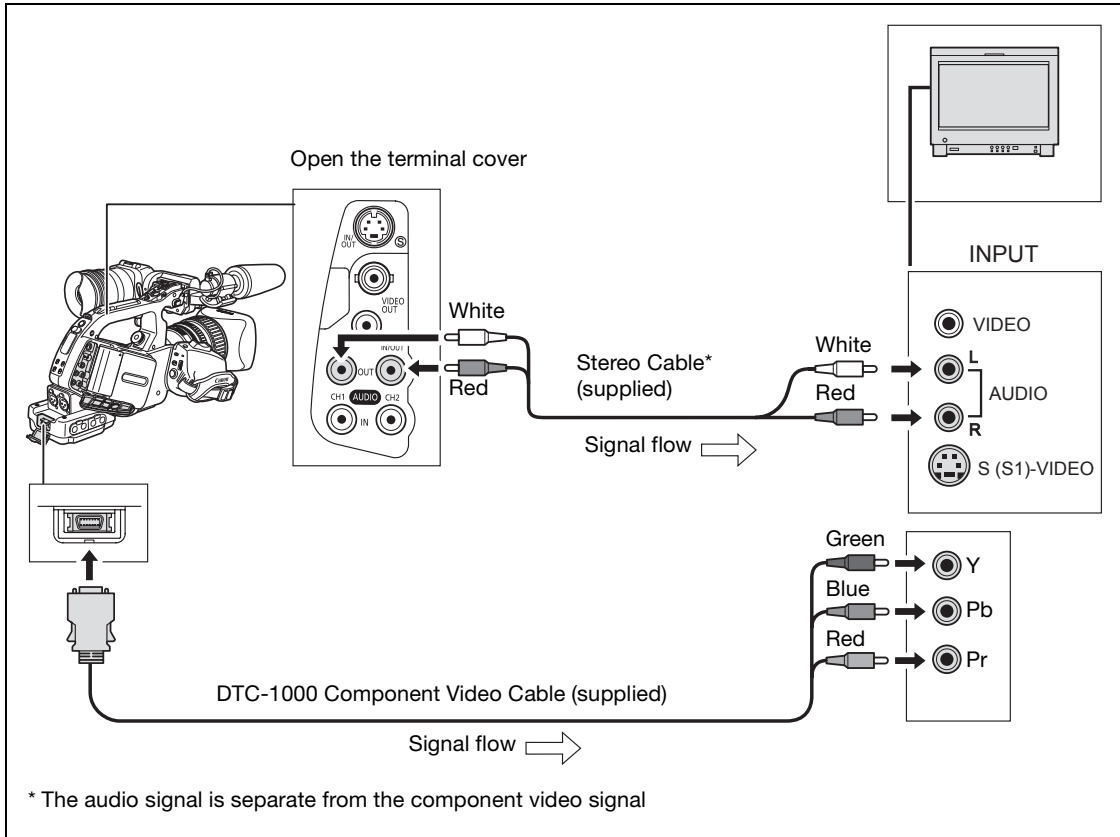

Select the appropriate component video signal depending on the TV or monitor you connect.

Open the menu and select [SIGNAL SETUP]. Select [COMP.OUT], select a setting option and close the menu.

3 Using the HDV/DV Terminal

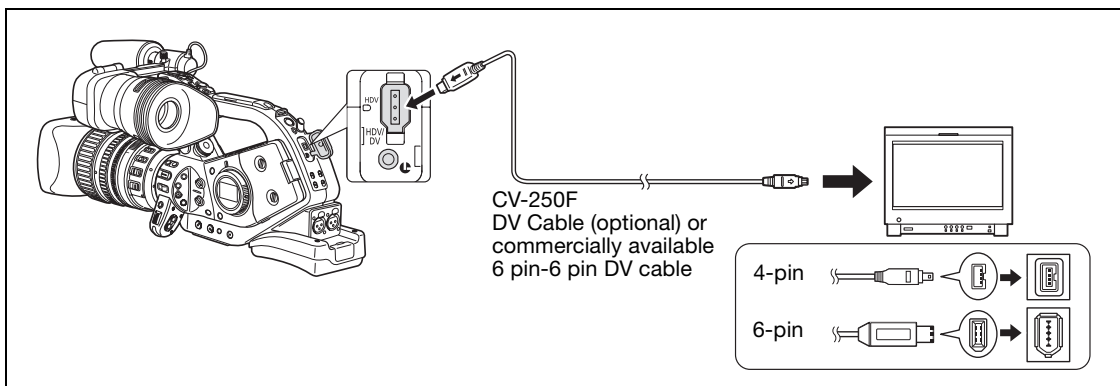

- When connecting the camcorder to a monitor or TV that supports DV input, you may need to carry out a procedure on the monitor or TV to recognize the camera.
- If necessary, turn on the DV conversion and select whether to convert a tape recorded in HD to SD with the following procedure.

Open the menu and select [SIGNAL SETUP]. Select [HD DOWN-CONV], select a setting option and close the menu.

4 Using the VIDEO IN/OUT or $\text{\textcircled{S}}$ (S-Video) IN/OUT Terminal

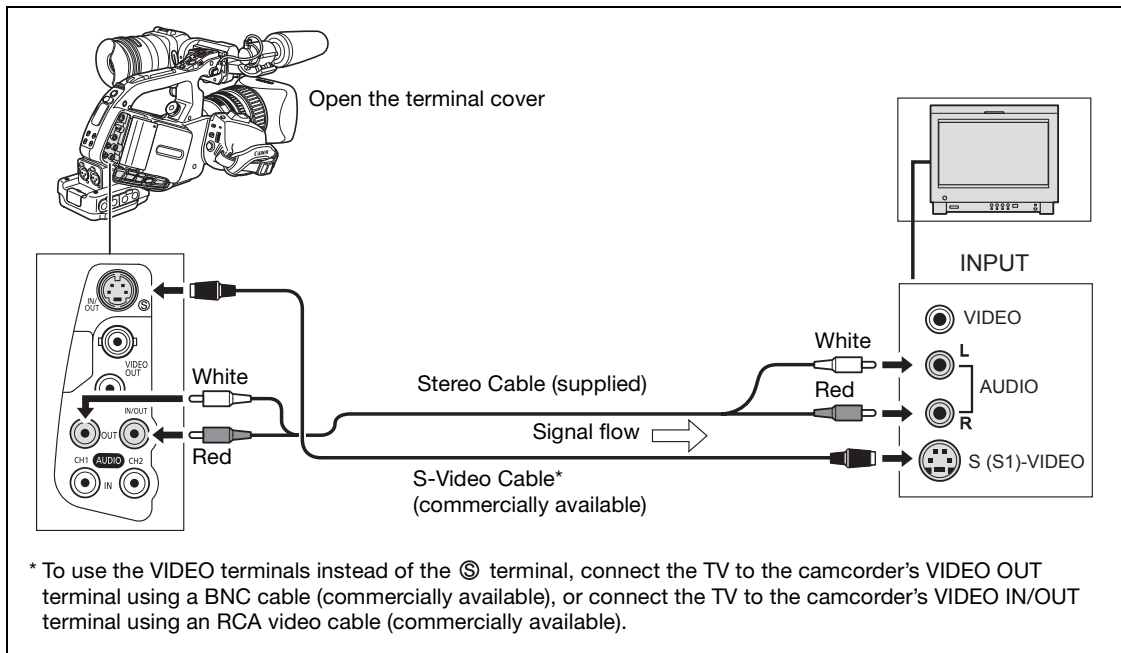

- i** We recommend powering the camcorder from a household power outlet.
- TV sets equipped with the WSS System:** Recordings made with a 16:9 aspect ratio (38) will be played automatically in widescreen mode whether you connect the camcorder to the TV using the S (S1-) VIDEO terminal or the VIDEO terminal.
- During fast forward playback, rewind playback and reverse playback of a tape recorded in HDV standard, the picture may be distorted.

Connection to a Standard Definition TV or Monitor

1 Using the COMPONENT OUT Terminal

- Refer to the connection diagram in the previous section (83).
- Select the appropriate component video signal depending on the TV or monitor you connect.
Open the menu and select [SIGNAL SETUP]. Select [COMP.OUT], select a setting option and close the menu.

2 Using the VIDEO IN/OUT or $\text{\textcircled{S}}$ (S-Video) IN/OUT Terminal

- Refer to the connection diagram in the previous section (84).
- If connecting to a TV set with a 4:3 aspect ratio, change the [LETTERBOX] setting appropriately.
Open the menu and select [SIGNAL SETUP]. Select [LETTERBOX], set it to [ON] and close the menu.

3 Using the SCART Adapter

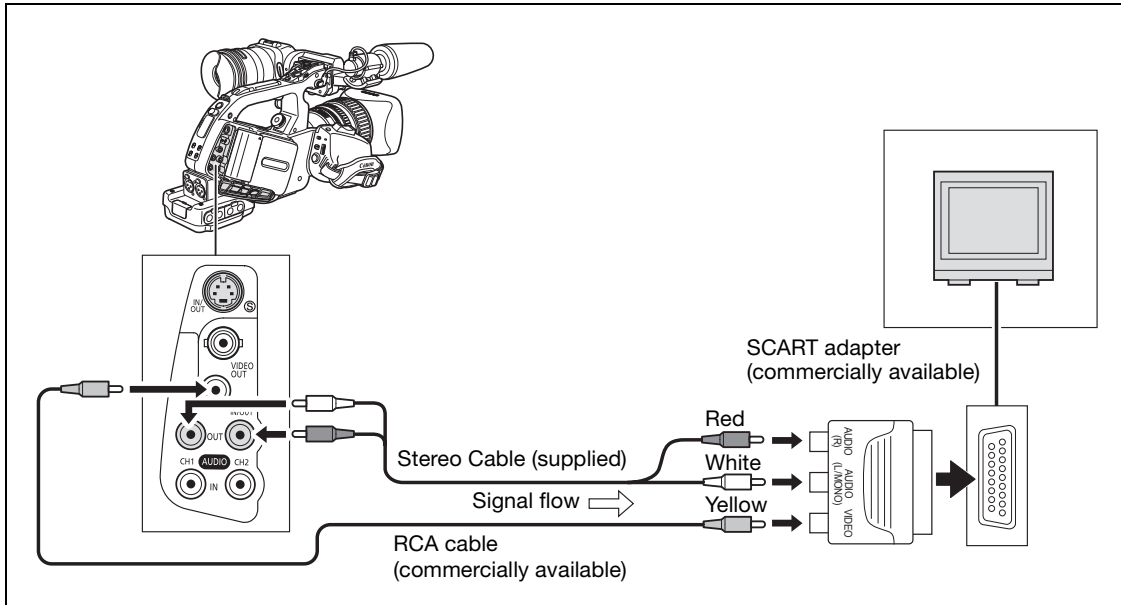

- If connecting to a TV set with a 4:3 aspect ratio, change the [LETTERBOX] setting appropriately.

Open the menu and select [SIGNAL SETUP]. Select [LETTERBOX], set it to [ON] and close the menu.



- We recommend powering the camcorder from a household power outlet.
- **TV sets equipped with the WSS System:** Recordings made with a 16:9 aspect ratio (□ 38) will be played automatically in widescreen mode whether you connect the camcorder to the TV using the S (S1-) VIDEO terminal or the VIDEO terminal.
- During fast forward playback, rewind playback and reverse playback of a tape recorded in HDV standard, the picture may be distorted.

Audio Output

Selecting the Audio Channel

You can select the channel for audio signal output from the **AUDIO** CH1/CH2 and the  (headphone) terminals.



Repeatedly press the **AUDIO OUTPUT CH** button to change the audio channel.

- Pressing the button will cycle between the audio channels in the following order: CH1/CH2 → CH1/CH1 → CH2/CH2 → ALL CH/ALL CH → CH1/CH2.
- During playback of a tape recorded with 4-channel audio (using another device) or while recording external video with 4-channel audio from the HDV/DV terminal, the output channels will be: CH1-3/CH2-4 → CH1-3/CH1-3 → CH2-4/CH2-4 → ALL CH/ALL CH.

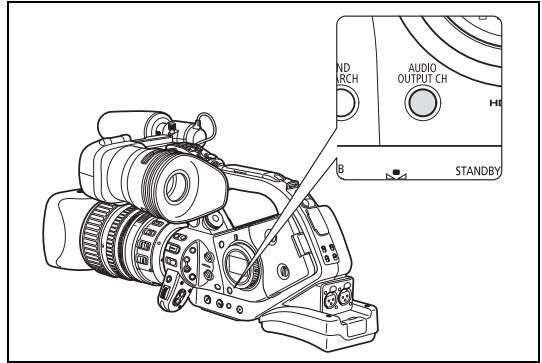

Selecting the Audio Output Level

You can boost the level of the audio output signal from the **AUDIO** CH1/CH2 terminals from 1 Vrms to 2 Vrms (+6 dB).

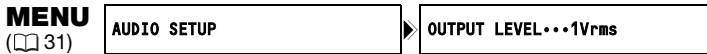

Open the menu and select **[AUDIO SETUP]**. Select **[OUTPUT LEVEL]**, select a setting option and close the menu.

Selecting the Audio Monitor

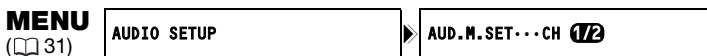

Open the menu and select **[AUDIO SETUP]**. Select **[AUD.M.SET]**, select a setting option and close the menu.

- You can also select the audio monitor using the wireless controller.
- If you selected **[MIX/VAR.]**, adjust the mix balance with the **[MIX BALANCE]** setting or using the **MIX BALANCE** buttons on the wireless controller.

Audio Output Selected	Audio Recordings on 2 Channels	Audio Monitor [AUD.M.SET]	Audio Recordings on 4 Channels
CH1/CH2 CH3/CH4 CH1-3/CH2-4	Left Output: L or CH1 Right Output: R or CH2	CH 1/2	Left Output: CH1 Right Output: CH2
		CH 3/4	Left Output: CH3 Right Output: CH4
		MIX/FIXED	Left Output: CH1+CH3 Right Output: CH2+CH4 Mix balance fixed at 1:1
		MIX/VAR.	Left Output: CH1+CH3 Right Output: CH2+CH4 Mix balance can be adjusted
CH1/CH1 CH3/CH3 CH1-3/CH1-3	Left Output: L or CH1 Right Output: L or CH1	CH 1/2	Both Outputs: CH1
		CH 3/4	Both Outputs: CH3
		MIX/FIXED	Both Outputs: CH1+CH3 Mix balance fixed at 1:1
		MIX/VAR.	Both Outputs: CH1+CH3 Mix balance can be adjusted
CH2/CH2 CH4/CH4 CH2-4/CH2-4	Left Output: R or CH2 Right Output: R or CH2	CH 1/2	Both Outputs: CH2
		CH 3/4	Both Outputs: CH4
		MIX/FIXED	Both Outputs: CH2+CH4 Mix balance fixed at 1:1
		MIX/VAR.	Both Outputs: CH2+CH4 Mix balance can be adjusted
ALL CH/ALL CH	Left Output: All channels Right Output: All channels	CH 1/2	Both Outputs: All channels
		CH 3/4	Both Outputs: All channels
		MIX/FIXED	Both Outputs: All channels Mix balance fixed at 1:1
		MIX/VAR.	Both Outputs: All channels Mix balance can be adjusted

Digital Video Control

This feature enables the camcorder to control the record and stop functions of an external digital device connected to the camcorder through the HDV/DV terminal. The device must comply with the IEEE1394 AV/C protocol. Use the optional CV-250F (4 pin-6 pin) DV cable or a commercially available 6 pin-6 pin DV cable to connect the external device.

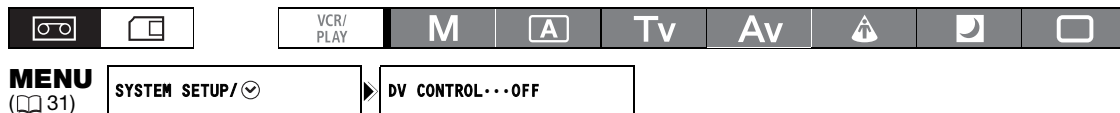

1. Open the menu and select [SYSTEM SETUP/☺]. Select [DV CONTROL], set it to [ON 

2. Press the Start/Stop button.

If the button was pressed while the camcorder was in record pause mode:

Camcorder and external device: start recording.





If the button was pressed while the camcorder was recording:

Camcorder and external device: stop recording (record pause mode).

If the button was pressed while the camcorder was not ready to start recording:

Camcorder: no change; External device: starts/stops recording following the camcorder's control. If you press the Start/Stop button again after solving the problem on the camcorder (inserting a cassette, etc.), the camcorder will start recording as the external device continues recording.



- While both this camcorder and a connected device are recording, if this camcorder stops recording because of a condition other than pressing the Start/Stop button (e.g., if the tape has reached its end), the connected device will continue recording.
- When this camcorder stops recording you may notice a brief interruption of the audio on the connected device.
- The status of the connected device is indicated as follows.
 -  ● Connected device is recording
 -  ■ Connected device is in record pause or stop mode
 -  --- Connected device is in a mode other than record pause or stop
 -  [DV CONTROL] is set to [ON 
- As long as the built-in rechargeable lithium battery is charged, the camcorder retains the DV control setting even if you turn the power off. Make sure to check the setting after using the DV control function, as the tape in the connected device may be overwritten.
- When connecting two DV Control-compatible Canon camcorders with a DV cable, make sure to set [DV CONTROL] on the other connected camcorder to [OFF].
- Up to 2 other devices can be connected to this camcorder for DV control.
- With some non-Canon devices the DV control may not work properly depending on the connected device.

Recording an External Video Signal (HDV/DV In, Analog Line-In)

You can record on the tape an external video signal, either from the HDV/DV input (SD or HD standard) or from the analog video input (SD standard).



HDV/DV In

When recording from an external digital device you can select the time code to be used for the recording made with this camcorder. Select [COPY] to keep the original time code of the video source, or [REGEN.] to use instead this camcorder's internal time code.

1. Open the menu, select [SIGNAL SETUP] and then select the [TIME CODE] submenu.
2. Select [HDV/DV IN], select a setting option and close the menu.
3. Connect the camcorder to the external video device.
For the connection diagram to a digital device refer to Section 3 of *Connecting to a Monitor/TV* (83).
4. Press the ● and || buttons (or the REC PAUSE button on the wireless controller).
 - The camcorder enters the record pause mode. In this mode you can monitor the picture on the screen.
 - If you press only the ● button, recording will start immediately.
5. Press the || button (or the PAUSE || button on the wireless controller) when the scene you wish to record appears.
Recording starts.
6. Press the ■ button to stop recording.

Analog Line-In

1. Open the menu and select [AUDIO SETUP]. Select [DV AUDIO], select a setting option and close the menu.
2. Connect the camcorder to the analog video device.
For the connection diagram to an analog device refer to Section 4 of *Connecting to a Monitor/TV* (84). Connect the supplied Stereo Cable to the AUDIO IN terminals on the camcorder.
3. Press the ● and || buttons (or the REC PAUSE button on the wireless controller).
 - The camcorder enters the record pause mode. In this mode you can monitor the picture on the screen.
 - If you press only the ● button, recording will start immediately.
4. Press the || button (or the PAUSE || button on the wireless controller) when the scene you wish to record appears.
Recording starts.
5. Press the ■ button to stop recording.

Concerning Copyright

Copyright Precaution

Certain pre-recorded video tapes, films and other materials, as well as some television programs are copyrighted. Unauthorized recording of these materials may violate copyright protection laws.

Copyright Signals

During playback: If you try to play back a tape that contains copyright control signals for protection of software, "COPYRIGHT PROTECTED PLAYBACK IS RESTRICTED" appears for a few seconds and the camcorder displays a blank blue screen. You cannot playback the contents of the tape.

During recording: If you try to record from software that contains copyright control signals for protection of software, "COPYRIGHT PROTECTED DUBBING RESTRICTED" appears. You cannot record the contents of the software.

You cannot record copyright protection signals to a tape using this camcorder.



We recommend powering the camcorder from a household power outlet.

Converting Analog Signals into Digital Signals (Analog-Digital Converter)

Using the camcorder you can convert analog video input signals to a digital video signal (SD standard) and output it through the HDV/DV terminal.

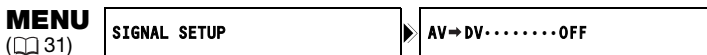

Open the menu and select **[SIGNAL SETUP]**. Select **[AV→DV]**, set it to **[ON]** and close the menu.



- Depending on the signal sent from the connected device, the conversion from analog to digital signals might not work properly (e.g., signals that include copyright protection signals or anomalous signals such as ghost signals).
- For normal use, set **[AV→DV]** to **[OFF]**. If it is set to **[ON]**, digital signals cannot be input via the camcorder's HDV/DV terminal.
- Depending on the software and the specifications of your computer, you may not be able to transfer converted signals via the HDV/DV terminal.



- We recommend powering the camcorder from a household power outlet.
- You can also press the **AV→DV** button on the wireless controller. Pressing the button will toggle the **AV→DV** conversion on and off.

Connecting to a Computer

To connect the camcorder to a computer you will need a computer equipped with an IEEE1394 (DV) terminal and video editing software with video capturing capability installed. Use the optional CV-250F (4 pin-6 pin) DV cable or a commercially available 6 pin-6 pin DV cable. For the minimum system requirements for video editing, refer to the instruction manual of the video editing software.

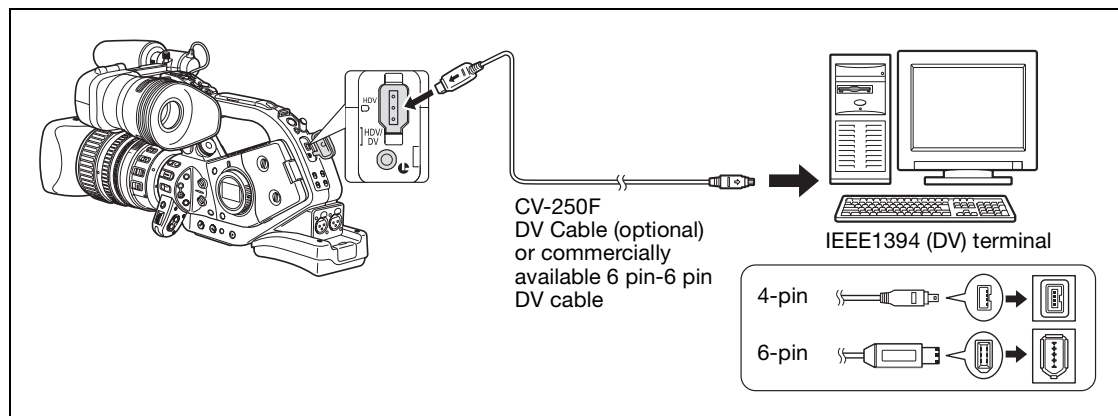

- Operation may not work correctly depending on the software and the specifications/settings of your computer.
- If the computer freezes while the camcorder is connected, disconnect and reconnect the DV cable. Should the problem persist, disconnect the cable, turn both the camcorder and the computer off and then on again and reconnect them.
- Make sure that the computer's video capturing system is compatible with the video signal standard you are using. If the computer is not compatible with the camcorder's video output signal, the camcorder may not be correctly detected or may not operate properly.



- Refer also to the instruction manual of the computer and the editing software.
- Adjust the [SIGNAL SETUP] ► [PLAYBACK STD] and [HD DOWN-CONV] settings in accordance with the video signal standards of the connected computer.
- For video output from the camcorder to the computer:
 - [HDV] output: Set [PLAYBACK STD] to [HDV] and [HD DOWN-CONV] to [OFF].
 - [DV] output: Set [PLAYBACK STD] to [DV].
 - [DV] output of a recording originally made in HDV standard: Set [PLAYBACK STD] to [HDV] and [HD DOWN-CONV] to [ON].
- For video input from the computer to the camcorder:
 - [HDV] input: Set [PLAYBACK STD] to [HDV] and [HD DOWN-CONV] to [OFF].
 - [DV] input: Set [PLAYBACK STD] to [DV].

Custom Preset Settings

You can select preset level for a number of picture-related parameters (23 parameters when recording movies, 17 when recording still images). A list of the parameters is given in the following table and you can find more detailed descriptions on page 97. After changing individual parameters to your preference, you can save the whole set as a custom preset file. You can also embed the data of the custom preset parameters currently in use within a still image recorded on the memory card.

Up to 9 different custom preset files can be saved on the camcorder* and up to 20 custom preset files can be saved on a memory card. Custom preset files can be copied between the camcorder and memory card.

Custom preset files saved with a Canon XL H1, XH G1 or XH A1 can be used with this camcorder. Custom preset files saved with this camcorder can be used on a Canon XH G1 or XH A1.

* Custom preset files 7 to 9 on the camcorder are predefined custom preset files, especially designed for specific scenes.

Custom Preset Parameters

GAM	Gamma curve**	Group 1 Parameters related to light and gradation
KNE	Knee point	
BLK	Black stretch/Black press	
PED	Master pedestal**	
SET	Setup level**	
SHP	Sharpness	Group 2 Parameters related to noise and definition of contour lines
HDF	Horizontal detail frequency	
DHV	Horizontal/vertical detail frequency	
COR	Coring	
NR1	Noise reduction 1**	
NR2	Noise reduction 2**	
CMX	Color matrix**	Group 3 Parameters related to color direction and intensity
CGN	Color gain	
CPH	Color phase	
RGN	Red gain	
GGN	Green gain	
BGN	Blue gain	
RGM	R-G matrix	Group 2 Parameters related to change in color
RBM	R-B matrix	
GRM	G-R matrix	
GBM	G-B matrix	
BRM	B-R matrix	
BGM	B-G matrix	

** Available only when recording movies.

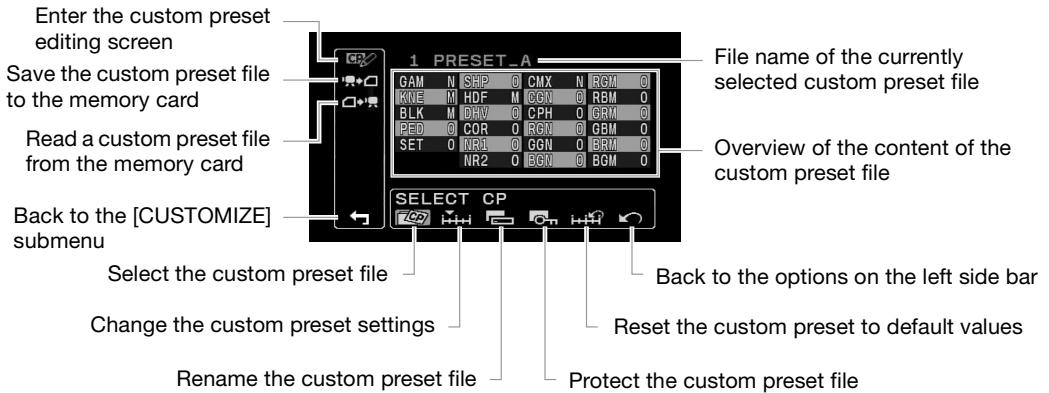

Changing Custom Preset Parameters



- 1. Open the menu, select [CUSTOMIZE] and then select the [CUSTOM PRESET] submenu.**
 The custom preset submenu appears.
- 2. Select [EDIT] from the column on the left.**
 The cursor will move to the bottom bar of the custom preset editing screen. To return one level back to the options on the column on the left, select [RETURN] and press the SET button.
- 3. From the bottom bar, select [SELECT CP] and then select the name of the custom preset file you want to change.**
 The overview display shows in shortened form the current settings of the parameters of the custom preset file selected.
- 4. From the bottom bar, select [TUNE].**
 The first parameter ([GAM]) of the custom preset file will be highlighted in blue.
- 5. Turn the SELECT dial to select a parameter you want to adjust and press the SET button. Make the adjustment or the selection as necessary and press the SET button.**

 - During the adjustment you can verify the effect on the screen.
 - Repeat this step to adjust all the parameters you want to change.
- 6. When you finish adjusting all the parameters you want to change in the custom preset file, select [RETURN], press the SET button and close the menu.**

- The custom preset parameters appear in one screen as 3-letter abbreviations followed by the current setting value. As you move between the items with the SELECT dial, the full name of the currently selected item and its current value will be displayed at the bottom of the screen.
- Protected custom preset files cannot be changed. If you attempt to change a protected file, the SELECT dial will start flashing.

Renaming a Custom Preset File

Follow steps 1-3 in *Changing Custom Preset Parameters* (□ 93) to select the custom preset file you want to rename.

1. From the bottom bar, select [RENAME].

The first character of the custom preset file name will start flashing.

2. Turn the SELECT dial to select a number, letter or punctuation mark and press the SET button.

- The next character of the custom preset file name will start flashing.
- Set the rest of the custom preset file name in the same way.

3. When you finish renaming the custom preset file, press the SET button.



You will return to the custom preset editing screen.

4. Close the menu.

Protecting a Custom Preset File

Follow steps 1-3 in *Changing Custom Preset Parameters* (□ 93) to select the custom preset file you want to protect.

1. From the bottom bar, select [PROTECT].

- The protection mark  will appear next to the custom preset file name.
- To cancel the protection, repeat the procedure for a custom preset file with the  mark.

Resetting a Custom Preset File

Follow steps 1-3 in *Changing Custom Preset Parameters* (□ 93) to select the custom preset file you want to reset to default values.

1. From the bottom bar, select [RESET].

A confirmation screen will appear.

2. Select [EXECUTE] and press the SET button.

You will return to the custom preset editing screen.

3. Close the menu.



Protected custom preset files cannot be reset. If you attempt to reset a protected file,  will start flashing.

Activating the Custom Preset Settings

1. Press the CUSTOM PRESET SELECT button.

- Repeatedly pressing the button will cycle through the available custom preset files. You can also set a custom key as [CP BKWD KEY] to cycle through the custom preset files in reverse order (from last to first) (75).
- When you are not using the custom preset settings, set the camcorder to **CP Off**.
- **CP** and the name of the selected custom preset file will flash on the screen. After 4 seconds, the file name will be replaced by the custom preset file number.

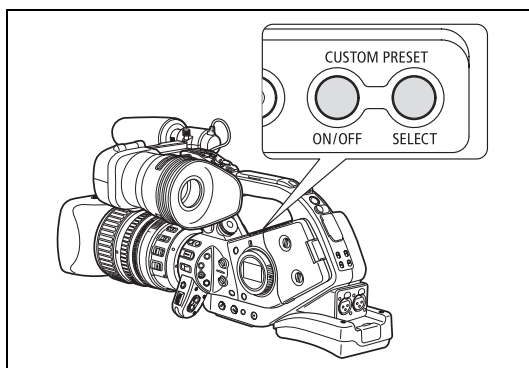

2. Press the CUSTOM PRESET ON/OFF button.

- **CP** and the name of the selected custom preset file will stay on and the custom settings will be activated. After 4 seconds, the file name will be replaced by the custom preset file number.

Copying a Custom Preset File to the Memory Card

1. Open the menu, select [CUSTOMIZE] and then select the [CUSTOM PRESET] submenu.

2. Select [**!>** CAMERA → CARD] from the column on the left.

3. From the bottom bar, select [**CP** SELECT CP] and then select the name of the custom preset file you want to copy to the card.

4. Select [**CP** SAVE POSITION] and select the file name under which you want to store the file on the memory card.

- Up to 20 custom preset files can be stored on the memory card. If you try to save more than 20 custom preset files one of the files on the card will be overwritten (you can select which file to overwrite).
- If there are no custom preset files saved on the memory card, the default file name will be "NEW_FILE".

5. Select [**→** EXECUTE] and in the confirmation screen select [EXECUTE] to copy the file.

6. Close the menu.

Reading a Custom Preset File from the Memory Card

1. Open the menu, select [CUSTOMIZE] and then select the [CUSTOM PRESET] submenu.

2. Select [**←** CARD → CAMERA] from the column on the left.

3. From the bottom bar, select [**CP** IMPORT] and then select the name of the custom preset file you want to read to the camcorder.

4. Select [**CP** SELECT POSITION] and select the preset number under which you want to store the file in the camcorder.

5. Select [**→** EXECUTE] and in the confirmation screen select [EXECUTE] to load the file.

6. Close the menu.

Reading a Custom Preset File from a Still Image

With the custom function [PHOTO BUTTON] (📖 100) you can select to save the custom preset settings currently in use along with a still image recorded in **CAMERA** mode (simultaneous recording, 📖 118). This is very useful when you want to load the custom preset file later by selecting the still image captured from a specific scene.



1. Select the still image that contains the custom preset file you want to read.

Use the **CARD** + / - buttons to move between the still images.

2. Open the menu, select [CUSTOMIZE] and then select [META DATA CP].

3. Select [📷➡️📷 CARD → CAMERA] from the column on the left.

4. From the bottom bar, select [👁️ SELECT POSITION] and select the preset number under which you want to store the file on the camcorder.

5. Select [➡️📷 EXECUTE] and in the confirmation screen select [EXECUTE] to load the file.

6. Close the menu.



Custom preset files 7 to 9 are predefined settings designed for specific scenes.

- These 3 custom preset files are protected and, as long as the protection is not removed, cannot be overwritten.
- Even if you deleted or changed the sample custom preset files, you can reset them to the original values by resetting all the camcorder's settings. Open the menu and select [SYSTEM SETUP/👇]. Select [RESET ALL] and select [YES] in the confirmation screen.
- After resetting custom preset files 1 to 6 with the [🔧 RESET] option, they will all contain the same default settings.

Custom Preset [7 VIDEO.C]	For playback on a consumer-level monitor. [BLK] = [PRESS], [PED] = -2, [SET] = -2
Custom Preset [8 CINE.V]	For playback on a monitor TV with a film-like feel. [GAM] = [CINE1], [KNE] = [LOW], [BLK] = [STRETCH], [SHP] = -4, [CMX] = [CINE1], [CGN] = -20, [CPH] = 5, [RBM] = -5, [GRM] = -5 [GBM] = -5, [BRM] = 5, [BGM] = 12
Custom Preset [9 CINE.F]	For video transfer to film. [GAM] = [CINE2], [KNE] = [LOW], [BLK] = [STRETCH], [SHP] = 6, [CMX] = [CINE2], [RGN] = -8

*All other settings are left at their neutral values.

[GAM] Gamma Curve

The gamma curve changes the overall look of the image. You can select from **[NORMAL]**, **[CINE1]** or **[CINE2]**.
[NORMAL]: standard gamma setting suitable for video.
[CINE1]: appropriate for video telecined from film.
[CINE2]: appropriate for transfer to film.

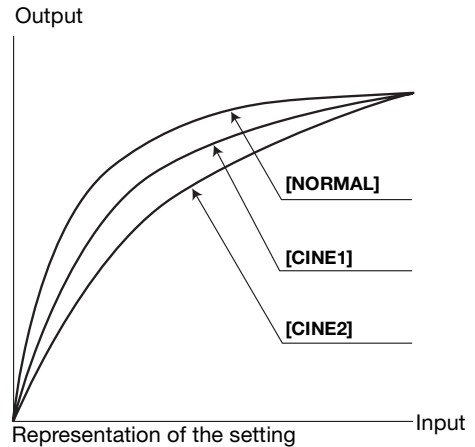

[KNE] Knee Point Adjustment

Adjust the dynamic range (knee point) in the highlight area of the image to prevent overexposure. You can select from **[AUTO]**, **[HIGH]**, **[MIDDLE]** or **[LOW]**.

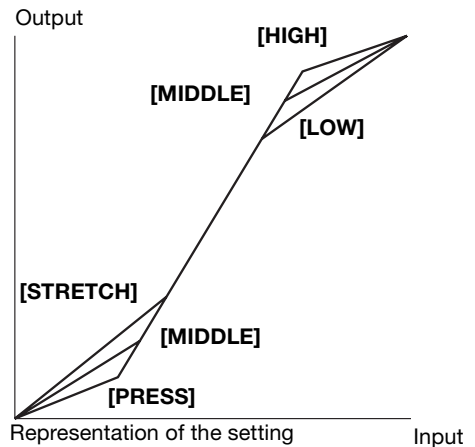

[BLK] Black Stretch/Black Press

Adjust the dynamic range in the shadow area of the image. You can select from **[STRETCH]**, **[MIDDLE]** or **[PRESS]**.
[STRETCH]: emphasizes contrast in the dark area.
[PRESS]: enhances or deepens darkness.



[PED] Master Pedestal

Adjust the master pedestal level in the range -9 to +9. The master pedestal lowers or raises the baseline of the luminance signal affecting only the shadow areas. Set [-] values to subdue the dark areas, or set [+] values to get more detail in the shadows.

[SET] Setup Level

Adjust the setup level in the range -9 to +9. The setup level lowers or raises the whole gamma curve controlling the darkest level of black in the image. Set [-] values to get a darker image, or set [+] values to get a brighter image.

- Depending on the value set for the master pedestal **[PED]**, the setup level may not be able to take a negative value. As a result, adjusting the setup value within a certain value range will have no effect.

[SHP] Sharpness

Adjust the sharpness level in the range -9 to +9. Noise artifacts caused by too-high sharpness settings can be reduced using the coring setting.

[HDF] Horizontal Detail Frequency

Select the horizontal definition of the image from [HIGH], **[MIDDLE]** or [LOW].

[DHV] Horizontal/Vertical Detail Balance

Adjust the balance between horizontal and vertical definition of the image in the range -9 (only horizontal) to +9 (only vertical).

[COR] Coring

Adjust the coring level in the range -9 to +9. Set higher coring values to help reduce the noise artifacts caused by high sharpness levels.

[NR1] Noise Reduction 1

You can select from **[OFF]**, [HIGH], [MIDDLE] or [LOW] to reduce the noise caused by shooting in dark places or by increasing the gain too much.

- When picture noise is already low due to the gain settings, the noise reduction function may not be noticeable.



When activated (settings other than [OFF]), moving subjects may leave a trailing afterimage.

[NR2] Noise Reduction 2

You can select from **[OFF]**, [HIGH], [MIDDLE] or [LOW] to reduce the noise caused by shooting fast moving objects. Results in an effect similar to applying the skin detail function over the whole picture.

- Unlike with the NR1 setting, a trailing afterimage will not appear.

[CMX] Color Matrix

Color mix affects the fundamental color settings and affects the feel of the whole image. You can select from **[NORMAL]**, [CINE1] or [CINE2].

[CGN] Color Gain

Adjust the color intensity in the range -50 to +50.

[CPH] Color Phase

Adjust the color phase in the range -9 to +9. Color phase affects the overall balance of the colors in the picture. Set [-] values to adjust the colors toward violet/red tones, or set [+] values to adjust the colors toward green/blue tones.

[RGN] R Gain 

Adjust the intensity of red tones in the range -50 to +50.

[GGN] G Gain 

Adjust the intensity of green tones in the range -50 to +50.

[BGN] B Gain 

Adjust the intensity of blue tones in the range -50 to +50.

[RGM] R-G Matrix 

The R-G matrix changes the tint of the picture along the cyan/green and red/magenta gradations without affecting blues. Adjust the level in the range -50 to +50.

[RBM] R-B Matrix 

The R-B matrix changes the tint of the picture along the cyan/blue and red/yellow gradations without affecting greens. Adjust the level in the range -50 to +50.

[GRM] G-R Matrix 

The G-R matrix changes the tint of the picture along the magenta/red and green/cyan gradations without affecting blues. Adjust the level in the range -50 to +50.

[GBM] G-B Matrix 

The G-B matrix changes the tint of the picture along the magenta/blue and green/yellow gradations without affecting reds. Adjust the level in the range -50 to +50.

[BRM] B-R Matrix 

The B-R matrix changes the tint of the picture along the yellow/red and blue/cyan gradations without affecting greens. Adjust the level in the range -50 to +50.

[BGM] B-G Matrix 

The B-G matrix changes the tint of the picture along the yellow/green and blue/magenta gradations without affecting reds. Adjust the level in the range -50 to +50.

Customized Functions

You can customize to your personal preferences many aspects of the operation of the camcorder, most of them governing how the camcorder operates in **CAMERA** mode. You can adjust up to 3 different custom function files and save them on the camcorder or to a memory card. By just reading the custom function file saved on the memory card with another XL H1S / XL H1A, you will instantly get a camcorder configured to operate in the same familiar manner you prefer.

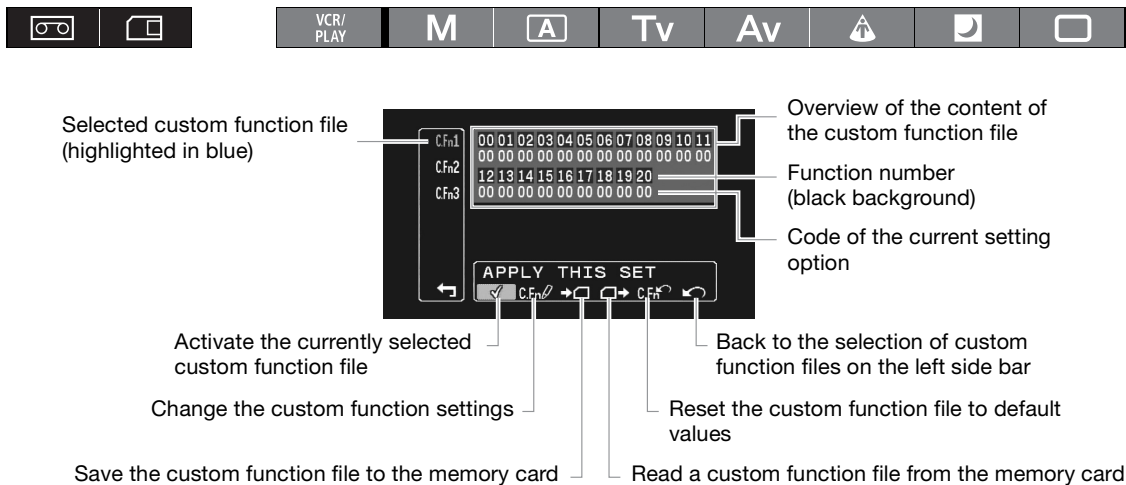

Changing the Custom Function Settings

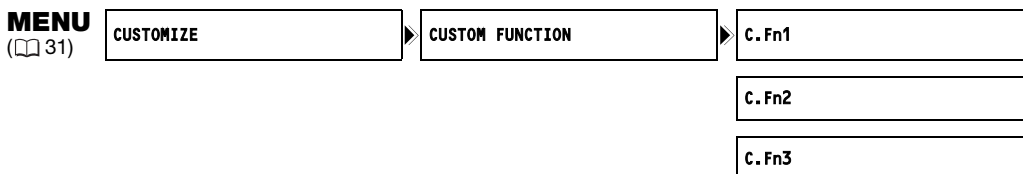

- Open the menu, select [CUSTOMIZE] and then select the [CUSTOM FUNCTION] submenu.**
The custom function editing screen appears.
- From the column on the left, select one of the 3 custom function files [C.Fn1] - [C.Fn3].**
 - The overview display shows the current settings of the custom function file currently selected.
 - The cursor will move to the bottom bar of the custom function editing screen. To return one level back to the options on the column on the left, select [RETURN] and press the SET button.
- From the bottom bar, select [C.Fn1 TUNE].**
The first function (00) of the custom function file will be highlighted in blue.
- Turn the SELECT dial to select a function you want to adjust and press the SET button. Make the selection as necessary and press the SET button.**
Repeat this step to adjust all the functions you want to change.
- When you finish adjusting all the functions in the custom function file, select [RETURN], press the SET button and close the menu.**



Custom functions appear in one screen represented only by the function number on the top (numbers 00 - 20 with a black background), and the code of the current setting immediately under it.

Resetting a Custom Function File

1. Open the menu, select [CUSTOMIZE] and then select the [CUSTOM FUNCTION] submenu.
2. From the column on the left select the custom function file you want to reset.
3. From the bottom bar select [CFn^o RESET].
4. Select [OK], press the SET button and close the menu.

Activating a Custom Function File

Even if you define a custom function file, as long as you do not activate it, the camcorder will function according to default settings.

1. Open the menu, select [CUSTOMIZE] and then select the [CUSTOM FUNCTION] submenu.
2. From the column on the left select the custom function file you want to activate.
3. From the bottom bar select [✓ APPLY THIS SET].
4. Select [ACTIVE] and press the SET button.
 - ✓ will appear next to the custom function file currently activated.

Copying a Custom Function File to the Memory Card

1. Open the menu, select [CUSTOMIZE] and then select the [CUSTOM FUNCTION] submenu.
2. From the column on the left select the custom function file you want to copy to the memory card.
3. From the bottom bar select [→□ SAVE TO CARD].
4. Select the destination file on the memory card [→□ 1] - [→□ 3].
5. Select [OK], press the SET button and close the menu.

When the operation is finished, "TASK COMPLETED" will appear on the screen.

Reading a Custom Function File from the Memory Card

1. Open the menu, select [CUSTOMIZE] and then select the [CUSTOM FUNCTION] submenu.
2. From the column on the left select the custom function file to which you want to read the settings from the memory card.
3. From the bottom bar select [□→ READ FROM CARD].
4. Select the source file on the memory card [□ 1 →] - [□ 3 →].
5. Select [OK], press the SET button and close the menu.

When the operation is finished, "TASK COMPLETED" will appear on the screen.



Custom function files saved with a Canon XH G1 or XH A1 cannot be used with this camcorder.

Availability of custom functions in each recording program/playback mode (Video)

Custom Function		M	A	Tv	Av				VCR/ PLAY
00	SHCKLSS WB/GN	WHITE BALANCE	●			●		– (OFF)	–
		GAIN	●		●		– (OFF)	–	
01	ZOOM RING CTRL ¹	●			●			– (NORMAL)	–
02	ZOOM SPEED ¹	●			●			– (NORMAL)	–
03	FOCUS RING CTRL ¹	●				●			–
04	BUTTONS OPER.1	MAGN.	●			●		–	–
		WB SET	●			●		–	–
05	BUTTONS OPER.2	REC REVIEW	●				●		–
		BARS/FADE	●				●		–
		END SEARCH	●				●		–
		GAIN SET	●		●			–	–
06	RINGS DIRECTION	ZOOM ¹	●			●			–
		FOCUS ¹	●			●			–
		IRIS	●	● ²	● ²	●		–	–
07	OPER.DIRECTION	CURSOR	●				●		●
		SHUTTER	●	● ²	●	● ²		–	–
08	IRIS LIMIT ¹	●	● ²	● ²	●		–	–	
09	PHOTO BUTTON	PHOTO + CP DATA	●				●		–
		PHOTO	●				●		–
		MAGNIFYING	●			●		–	–
10	MARKER LEVEL	MARKER	●				●		–
		ASPECT	●				●		–
		SAFETY	●				●		–
11	FAST BW-MOD	MAGN.	●			●		–	–
		PEAKING	●			●		–	–
12	OBJ DST UNIT ¹	●				●		–	
13	ZOOM INDICATOR ¹	●				●		–	
14	COLOR BARS	●				●		–	
15	1kHz TONE	●				●		–	
16	WIRELESS REMOTE	●				●		●	
17	LANC AE SHIFT	AE SHIFT	–		●			–	–
		IRIS	●		●			–	–
18	TALLY LAMP	● ³				● ³		● ³	
19	LED	●				●		●	
20	CUSTOM REC	CHARACTER REC	●			●			–
		MAGNIFYING REC	●			●		– (OFF)	–

¹ Only with a lens that supports this function.

² Only during exposure lock.

³ Only if [LED] is set to a setting other than [OFF]. When [LED] is set to [OFF], this function will be set to [OFF] as well.

Availability of custom functions in each recording program/playback mode (Still Images)

Custom Function		M	A	Tv	Av				VCR/ PLAY
00	SHCKLSS WB/GN	WHITE BALANCE	– (OFF)			– (OFF)			–
		GAIN	– (OFF)			– (OFF)			–
01	ZOOM RING CTRL	REC REVIEW	●		●			– (OFF)	–
02	ZOOM SPEED ¹		– (FAST)		– (FAST)				–
03	FOCUS RING CTRL ¹		●		●				–
04	BUTTONS OPER.1	MAGN.	●		●			–	–
		WB SET	●		●			–	–
05	BUTTONS OPER.2	REC REVIEW	–		–				–
		BARS/FADE	–		–				–
		END SEARCH	–		–				–
		GAIN SET	●		●		–		–
06	RINGS DIRECTION	ZOOM ¹	●		●				–
		FOCUS ¹	●		●				–
		IRIS	●	● ²	● ²	●		–	–
07	OPER.DIRECTION	CURSOR	●		●				●
		SHUTTER	●	● ²	●	● ²		–	–
08	IRIS LIMIT ¹		●	● ²	● ²	●		–	–
09	PHOTO BUTTON		–		–				–
10	MARKER LEVEL	MARKER	●		●				–
		ASPECT	–		–				–
		SAFETY	–		–				–
11	FAST BW-MOD	MAGN.	●		●			–	–
		PEAKING	●		●			–	–
12	OBJ DST UNIT ¹		●		●			–	
13	ZOOM INDICATOR ¹		●		●			–	
14	COLOR BARS		–		–			–	
15	1kHz TONE		–		–			–	
16	WIRELESS REMOTE		●		●			●	
17	LANC AE SHIFT	AE SHIFT	–		●			–	–
		IRIS	●		●			–	–
18	TALLY LAMP		–		–			–	
19	LED		●		●			●	
20	CUSTOM REC		–		–			–	

¹ Only with a lens that supports this function.

² Only during exposure lock.

List of Custom Functions and Setting Options

The default value for all items is the option assigned to 00.

00 [SHCKLSS WB/GN] Shockless White Balance/Gain

The shockless setting will ensure a softer transition when changing the white balance or gain.

[CAMERA] mode: Shockless gain will not function when changing the gain setting from/to -3 dB or +36 dB.

Setting Options: [WHITE BALANCE] Shockless white balance: **[OFF]**, [ON]

[GAIN] Shockless gain: **[OFF]**, [ON]

01 [ZOOM RING CTRL] Zoom Ring Control

Selects the sensitivity of the response when operating the zoom ring.

Setting Options: **[NORMAL]**, [SLOW], [FAST]

02 [ZOOM SPEED] Zoom Speed

Selects the set of 16 constant zoom speeds that will be available when the ZOOM SPEED switch is set to CONSTANT.

- When the zoom speed is too fast (less than 2 seconds end-to-end), the camcorder will have more trouble focusing automatically while zooming.

Setting Options: [NORMAL], [SLOW], [FAST]

03 [FOCUS RING CTRL] Focus Ring Control

Selects the sensitivity of the response when operating the focus ring.

Setting Options: [NORMAL], [SLOW], [FAST].

04 [BUTTONS OPER.1] Buttons Operation (1/2)

You can set that a long press be required to activate various buttons to prevent their accidental operation. When you select [LONG PUSH], keep the button pressed for more than 1 second.

Setting Options: [MAGN.] EVF MAGNIFYING button: [ONE PUSH], [LONG PUSH]
[WB SET] WHITE BALANCE  button: [ONE PUSH], [LONG PUSH]

05 [BUTTONS OPER.2] Buttons Operation (2/2)

You can set that a long press be required to activate various buttons to prevent their accidental operation. When you select [LONG PUSH], keep the button pressed for more than 1 second.

Setting Options: [REC REVIEW]  (record review) button: [ONE PUSH], [LONG PUSH]
[BARS/FADE] BARS/FADE buttons: [ONE PUSH], [LONG PUSH]
[END SEARCH] END SEARCH button: [ONE PUSH], [LONG PUSH]
[GAIN SET] SET button for gain fine-tuning: [ONE PUSH], [LONG PUSH]

06 [RINGS DIRECTION] Rings Direction

Changes the direction of the adjustment when turning the camcorder's rings.

Setting Options: [ZOOM] Zoom ring:

[NORMAL] - turn up for wide angle **W**, [REVERSE] - turn down for wide angle **W**.

[FOCUS] Focus ring:

[NORMAL] - turn up to focus closer, [REVERSE] - turn down to focus closer.

[IRIS] Iris ring:

[NORMAL] - turn up to close the aperture, [REVERSE] - turn down to close the aperture.

07 [OPER.DIRECTION] Operation Direction

Changes the direction of the adjustment when pressing the SHUTTER buttons or when operating the SELECT dial as a cursor (for example, while selecting setting options in the menu screens or in the index screen).

Setting Options: [CURSOR] SELECT dial for menu navigation:

[NORMAL] - turn up to move left in the menu, [REVERSE] - turn down to move left in the menu.

[SHUTTER] Shutter buttons:

[NORMAL] - press the ▲ button for a faster shutter speed, [REVERSE] - press the ▼ button for a faster shutter speed.

08 [IRIS LIMIT] Iris Limit

Activates the iris limit. With the HD 20x L IS III lens, when set to [ON] you can close the aperture down to F9.5; when set to [OFF] you can close the aperture down to F22 (or completely -[CLOSE]- in **M** Manual mode, **Av** mode or during exposure lock).

Setting Options: [OFF], [ON]

09 [PHOTO BUTTON] Photo Button

Selects the function of the PHOTO button in **CAMERA** mode. You can enable recording still images while recording video (simultaneous recording) or assign to the PHOTO button the same function as the EVF MAGNIFYING button. When set to [PHOTO + CP DATA] the custom preset settings currently in use will be recorded along with the still image.

Setting Options: [PHOTO + CP DATA], [PHOTO], [MAGNIFYING], [OFF]

10 [MARKER LEVEL] Markers' Intensity Level  

Changes the intensity of the markers displayed on the screen to 40% (gray) or 100% (white).
 Setting Options: [MARKER] Level/center/grid markers: **[100%]**, [40%]
 [ASPECT] Aspect ratio guides: **[100%]**, [40%]
 [SAFETY] Safety zone guides: **[100%]**, [40%]

11 [FAST BW-MOD] Focus Assist Function B&W Display Mode  

Changes the display mode to black & white while the focus assist functions are activated.
 Setting Options: [MAGN.] While the Magnifying function is active: **[OFF]**, [ON]
 [PEAKING] While the Peaking function is active: **[OFF]**, [ON]

12 [OBJ DST UNIT] Object Distance Units Display  

Selects the units meters or feet for the display of the distance to the object.
 Setting Options: **[m (meter)]**, [ft (feet)]

13 [ZOOM INDICATOR] Zoom Indicator Display  

Selects the display of the zoom indicator between a graphic bar and a numeric display.
 Setting Options: **[BAR]**, [NUMBER]





14 [COLOR BARS] Color Bars Signal  

Selects the type of signal to use to produce the color bars: EBU color bars (type 1) or SMPTE color bars (type 2).
 Setting Options: **[TYPE 1]**, [TYPE 2]

15 [1kHz TONE] 1 kHz Reference Audio Signal  

Selects the strength of the audio signal.
 Setting Options: **[OFF]**, [-12dB], [-18db], [-20dB]

16 [WIRELESS REMOTE] Wireless Remote Controller  

Selects the remote sensor mode that the camcorder will accept. When set to [OFF ] the camcorder will not accept commands from wireless controllers.
 Setting Options: [ 1], [ 2], [OFF ]

17 [LANC AE SHIFT] AE SHIFT Dial on a  Controller  

Selects the function of the AE SHIFT dial on the optional ZR-2000 Zoom Remote Controller so you can use it to adjust the exposure compensation or the aperture value.
 Setting Options: **[AE SHIFT]**, [IRIS]

18 [TALLY LAMP] Tally Lamp  

Selects the operation of the tally lamp. Even if set to [OFF], the tally lamp will turn on when receiving a command from the wireless controller.
 Setting Options: **[ON]**, [BLINK], [OFF]

19 [LED] LED Indicators  

Selects the operation of the LED indicators on the camcorder. When set to [TYPE 1], all LED indicators (including that of the HDV/DV terminal) will be on. When set to [TYPE 2] all LED indicators will be on, except for that of the HDV/DV terminal.
 Setting Options: **[TYPE 1]**, [TYPE 2], [OFF]

20 [CUSTOM REC] Custom Recording  

Selects whether to embed the on-screen character displays (date and time) as part of the video recording and whether to record on the tape the enlarged image when using the Magnifying focus assist function.

- When [CHARACTER REC] is set to [ON], the menu option [TV SCREEN] will not be available and [COMP.OUT] will automatically be set to [1080i/576i] and you will not be able to select [576i].

Setting Options: [CHARACTER REC] Recording of superimposed on-screen displays: **[OFF]**, [ON]
 [MAGNIFYING REC] Recording of enlarged image while the Magnifying function is active: **[OFF]**, [ON]

Customized On-Screen Displays

You can customize which icons to display on the screen according to your personal preferences and needs. You can save your personal settings as a custom display file on the camcorder or on the memory card. To activate the on-screen displays at the level that you customized, repeatedly press the EVF DISPLAY button (□ 37).

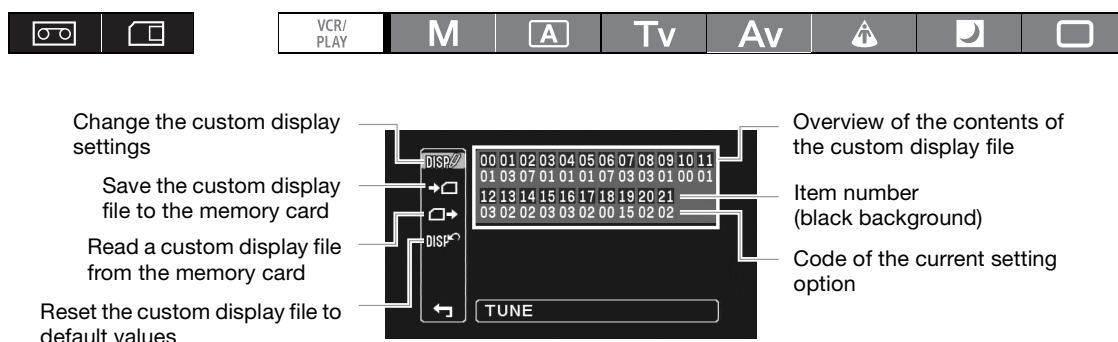

Changing the Custom Display Settings

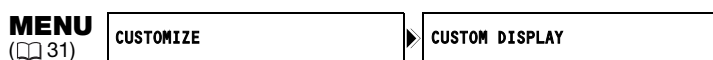

1. **Open the menu, select [CUSTOMIZE] and then select [CUSTOM DISPLAY].**
The custom display editing screen appears. The overview display shows the current settings of the custom display file.
2. **From the column on the left, select [DISP/TUNE].**
The first item (00) of the custom display file will be highlighted in blue.
3. **Turn the SELECT dial to select a display item you want to change and press the SET button. Make the selection as necessary and press the SET button.**
Repeat this step to adjust all the items you want to change.
4. **When you finish changing all the items in the custom display file, select [RETURN], press the SET button and close the menu.**
5. **Repeatedly press the EVF DISPLAY button to select the display level you customized.**

i Custom display items appear in one screen represented only by the item number on the top (numbers 00 – 21 with a black background), and the code of the current setting immediately under it.

Resetting a Custom Display File

1. **Open the menu, select [CUSTOMIZE] and then select [CUSTOM DISPLAY].**
2. **From the column on the left select [DISP/RESET].**
3. **Select [OK], press the SET button and close the menu.**

Copying a Custom Display File to the Memory Card

1. **Open the menu, select [CUSTOMIZE] and then select [CUSTOM DISPLAY].**
2. **From the column on the left select [SAVE TO CARD].**
3. **Select [OK], press the SET button and close the menu.**

When the operation is finished, "TASK COMPLETED" will appear on the screen.

Reading a Custom Display File from the Memory Card

1. Open the menu, select [CUSTOMIZE] and then select [CUSTOM DISPLAY].
2. From the column on the left select [□→READ FROM CARD].
3. Select [OK], press the SET button and close the menu.

When the operation is finished, "TASK COMPLETED" will appear on the screen.



Custom display files saved with a Canon XH G1 or XH A1 cannot be used with this camcorder.

List of Custom Display Items and Setting Options

00 [REC PROGRAMS] Recording Mode Icon

Setting Options: [OFF], [ON]

01 [CAMERA DATA1] Camera Data (1/2)

Setting Options: [F NUMBER]* Aperture value display: [OFF], [ON]
[SHUTTER SPEED] Shutter speed display: [OFF], [ON]

* Setting applicable only when using lenses with iris control.

02 [CAMERA DATA2] Camera Data (2/2)

Setting Options: [EXPOSURE] Exposure indicator and exposure displays: [OFF], [ON]
[WHITE BALANCE] White balance icons and displays: [OFF], [ON]
[GAIN] Gain icons and displays: [OFF], [ON]

03 [ZOOM] Zoom Indicator

You can select to display the zoom indicator* permanently or only when operating the zoom.

Setting Options: [OFF], [ON(NORMAL)], [ON(ALWAYS)]

* Setting applicable only when using lenses with zoom control (variable focal length).

04 [FOCUS] Focus Distance Display

You can select to display the focusing distance* permanently or only when operating the focus.

Setting Options: [OFF], [ON(NORMAL)], [ON(ALWAYS)]

* Setting applicable only when using lenses with autofocus function.

05 [ND] ND Filter displays

Setting Options: [OFF], [ON]

* Setting applicable only when using lenses with a built-in ND filter.

06 [IMAGE EFFECTS] Image Effects

Setting Options: [SKIN DETAIL] Skin detail icon: [OFF], [ON]
[SELECTIVE NR] Selective NR icon: [OFF], [ON]
[COLOR CORRECTION] Color correction icon: [OFF], [ON]

07 [F.ASSIST FUNC.] Focus Assist Functions

Setting Options: [PEAKING] Peaking function icon: [OFF], [ON]
[MAGNIFYING] Magnifying function icon: [OFF], [ON]

08 [CUSTOMIZE] Customized Functions

Setting Options: [CUSTOM PRESET] Icon of the custom preset file currently active: [OFF], [ON]
[CUSTOM FUNCTION] Icon of the custom function file currently active: [OFF], [ON]

09 [RECORDING STD] HD Standard Icon

Setting Options: [OFF], [ON]

10 [DV REC MODE] Recording Mode in Standard Definition

Setting Options: [OFF], [ON]

11 [FRAME RATE] Frame Rate Display

Setting Options: [OFF], [ON]

12 [TAPE] Tape-Related Icons and Displays

Setting Options: [TIME CODE] Time code display: [OFF], [ON]
[OPERATION MODE] Icon of the current tape operation: [OFF], [ON]
[DV CONTROL] DV control icon: [OFF], [ON]

13 [TAPE REMAINDER] Remaining Time on the Tape

You can select to display the tape remainder permanently or only the warning when the tape is about to end.
Setting Options: [OFF], [NORMAL], [WARNING]

14 [TAPE/CARD] Tape/Card-Related Displays

Setting Options: [EXT CONTROL] Icon of the external control mode (**POWER** dial set to EXT. CONTR.): [OFF], [ON]
[BARS/FADE] Icon of the color bars or fader: [OFF], [ON]
[IMG SIZE/QUALITY] Icon of the size and quality of the still image: [OFF], [ON]

15 [LIGHT METERING] Light Metering-Related Displays

Setting Options: [SPOT AE POINT] Bracketing frames when Spot AE metering is active: [OFF], [ON]
[LIGHT METERING] Icon of the metering mode currently active: [OFF], [ON]

16 [CARD] Icons Related to Recording Still Images

Setting Options: [DRIVE MODE] Icon of the drive mode currently active: [OFF], [ON]
[FLASH] Icon of the flash mode currently active: [OFF], [ON]

17 [CARD REMAINDER] Remaining Still Images on the Memory Card

You can select to display the information regarding the number of still images available on the memory card permanently or only the warning when the memory card is about to get full.
Setting Options: [OFF], [NORMAL], [WARNING]

18 [AUDIO] Audio-Related Displays

Setting Options: [WIND SCREEN] Icon of the wind screen function: [OFF], [ON]
[AUDIO MODE] Icon of the audio mode: [OFF], [ON]
[OUTPUT CH] Icon of the audio channel output: [OFF], [ON]

19 [WARNING/STATUS] Warning and Status Icons

Setting Options: [LENS] Lens-related warning icon: [OFF], [ON]
[CONDENSATION] Condensation warning icon: [OFF], [ON]
[CHARACTER REC] Character recording warning icon: [OFF], [ON]
XLH13 [SDI] Warning icon when on-screen displays are embedded in the SDI output:
[OFF], [ON]

20 [BATTERY] Battery-Related Displays

You can select to display the information regarding the battery pack permanently or only the warning when the battery is almost empty.
Setting Options: [OFF], [NORMAL], [WARNING]

21 [WIRELESS REMOTE] Wireless Remote Display

You can select to display the information regarding the wireless controller permanently or only related warnings.
Setting Options: [OFF], [NORMAL], [WARNING]

Location of the Custom Displays

CAMERA / EXT. CONT.

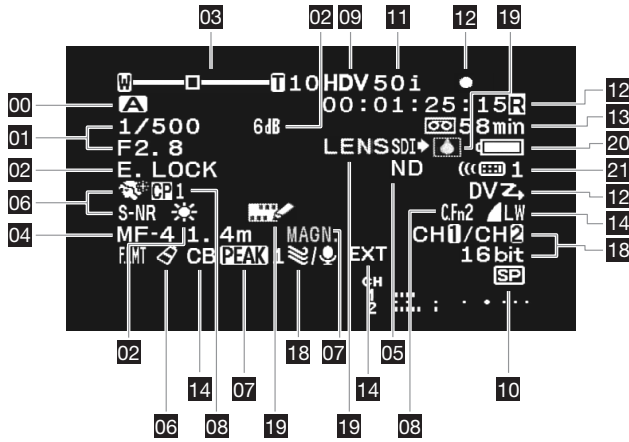

CAMERA · CARD

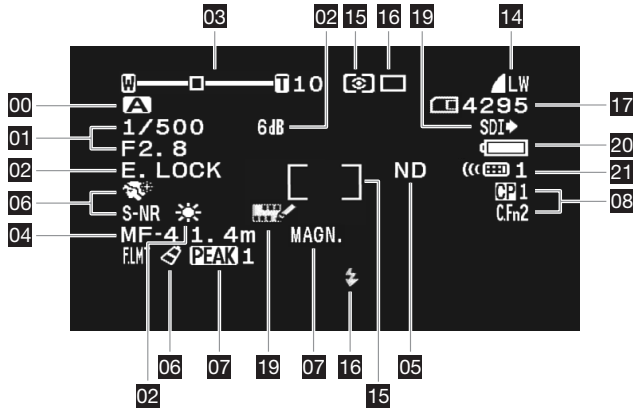

Customization

Playing Back a Tape

If the playback picture is distorted, clean the video heads using a Canon DVM-CL video head cleaning cassette or a commercially available digital video head cleaning cassette (☐ 144).

Select a playback standard according to the tape you wish to play back.

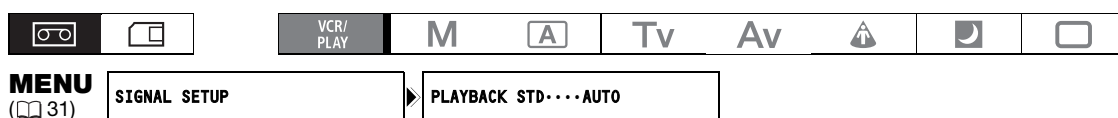
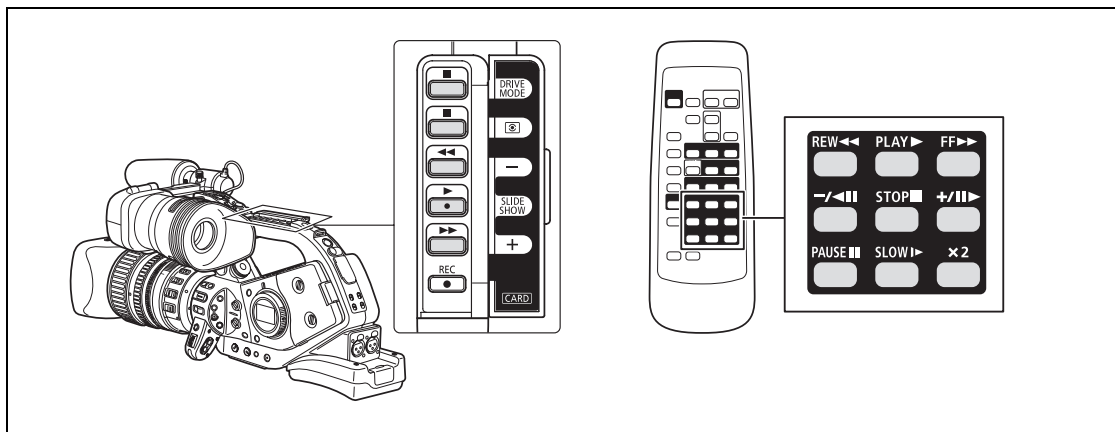

1. Set the **POWER** dial to **VCR/PLAY**.
2. Open the menu and select **[SIGNAL SETUP]**. Select **[PLAYBACK STD]** and set it to **[AUTO]**, **[HDV]** or **[DV]** to match the tape you wish to playback.
3. Close the menu.

Special Playback Modes

All special playback modes except for fast forward playback, rewind playback and playback pause can only be operated with the wireless controller.

(HDV)

▶|| (playback pause)

To pause playback, press the **||** button on the camcorder or the **PAUSE ||** button on the wireless controller during normal playback.

◀◀ (rewind playback) / ▶▶ (fast forward playback)

Press down and hold the **◀◀** or **▶▶** button on the camcorder or the **REW ◀◀** or **FF ▶▶** button on the wireless controller during normal playback, rewind or fast forward to enter the fast playback at 8x the normal playback speed.

◀ x1 (reverse playback)

Press the **-/◀||** button on the wireless controller during normal playback. Press the **▶** (play) button to return to normal playback.

▬▬ (frame advance)

Plays back frame-by-frame. Repeatedly press the button on the +/▬▬ wireless controller during playback pause. Hold the button pressed down to enter the continuous frame advance playback.

▬▬ (slow forward)

Plays back at about 1/3 normal speed. Press the SLOW ▬▬ button on the wireless controller during normal or reverse playback. Press the ► (play) button to return to normal playback.



▬▬ (playback pause)

To pause playback, press the ▬▬ button on the camcorder or the PAUSE ▬▬ button on the wireless controller during normal playback.

◀◀ (rewind playback) / ▶▶ (fast forward playback)

Plays back the tape at 11.5 times normal speed (forward or reverse). Press down and hold the ◀◀ or ▶▶ button on the camcorder or the REW ◀◀ or FF ▶▶ button on the wireless controller during normal playback, rewind or fast forward to enter the fast playback.

◀▬▬ (frame reverse) / ▬▬ (frame advance)

Plays back frame-by-frame. Press the -/◀▬▬ or +/▬▬ button on the wireless controller repeatedly during playback pause. Hold the button pressed down to enter the continuous frame advance/reverse playback.

◀▬ (slow reverse) / ▬▬ (slow forward)

Plays back at about 1/3 normal speed. Press the SLOW ▬▬ button on the wireless controller during normal or reverse playback. Press the ► (play) button to return to normal playback.

◀ x1 (reverse playback)

Press the -/◀▬ button on the wireless controller during normal playback. Press the ► (play) button to return to normal playback.

◀ x2 (reverse x2 playback) / x2 ▶ (forward x2 playback)

Plays back at 2 times normal speed. Press the X 2 button on the wireless controller during normal or reverse playback. Press the ► (play) button to return to normal playback.



- The sound will be muted during special playback modes.
- The picture may become distorted during some special playback modes.
- The camcorder stops the tape automatically after 4 minutes 30 seconds in playback pause mode to protect the tape and video heads.
- During fast forward playback, rewind playback and reverse playback of a tape recorded in HDV standard, the picture may be distorted.
- The picture may be slightly distorted at the switch point between recordings in HDV and DV standards on the tape.

Returning to a Pre-marked Position

If you wish to return to a particular scene later, mark the point with the zero set memory, and the tape will stop at that point when you rewind/fast forward the tape.

This function is operated with the wireless controller.



1. During playback, press the ZERO SET MEMORY button at the point you wish to return to later.

- The tape counter is reset to 0:00:00 and the **M** mark appears.
- To cancel, press the ZERO SET MEMORY button again.

2. Stop the playback.

3. Rewind the tape.

- If the tape counter shows a negative value, fast forward the tape instead.
- The tape stops automatically at "0:00:00" and the **M** mark disappears.
- The tape counter changes to time code.



- The zero set memory may not function correctly if the time code has not been recorded consecutively.
- The zero set memory function may not work correctly if you mix recordings in HDV and DV standards on the same tape.

Index Search

With the index search you can locate any point you have marked beforehand with an index signal (□ 76). This function is operated with the wireless controller.



1. Press the SEARCH SELECT button to display the icon.

2. Press the or button to begin searching.

- Press more than once to search for further index signals (up to 10 times).
- Press the STOP  button to stop searching.



- Playback may start slightly before or after the index signal.
- The index search function may not work correctly if you mix recordings in HDV and DV standards on the same tape.

Date Search

You can locate the change of the date/time zone with the date search function.

This function is operated with the wireless controller.



1. Press the **SEARCH SELECT** button to display the icon.

2. Press the **◀◀** or **▶▶** button to begin searching.

- Press more than once to search for further date changes (up to 10 times).
- Press the **STOP** button to stop searching.



- A recording of longer than a minute per date/time zone is required.
- The date search may not function if the data code is not correctly displayed.
- The date search function may not work correctly if you mix recordings in HDV and DV standards on the same tape.

Data Code

The camcorder maintains a data code containing the recording date and time and other camera data such as shutter speed, gain and exposure (f-stop).



Selecting the Data Code

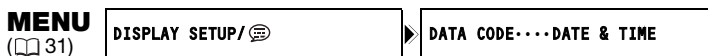

Open the menu and select **[DISPLAY SETUP/ⓘ]**. Select **[DATA CODE]**, select a setting option and close the menu.

Displaying the Data Code

Press the **DATA CODE** button on the wireless controller.



If you turn off the camcorder, the data code will not appear the next time you turn it on.

Six-Second Auto Date

The date and time appear for 6 seconds when you begin playback, or to indicate that the date or time zone in the recording has changed.

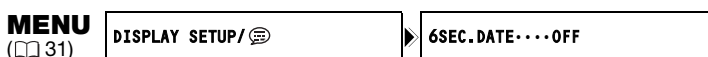

Open the menu and select **[DISPLAY SETUP/ⓘ]**. Select **[6SEC.DATE]**, set it to **[ON]** and close the menu.

Remote Sensor Mode

Two remote sensor modes and an off setting are available to prevent interference from other Canon wireless controllers being used nearby.

To change the remote sensor mode of the camcorder

Change the custom function [WIRELESS REMOTE] (☐ 105).

To change the remote sensor mode of the wireless controller

While holding the REMOTE SET button pressed down, press and hold the ZOOM T button for more than 2 seconds to change the wireless controller to mode 2.

To change the wireless controller to mode 1, press and hold the REMOTE SET and ZOOM **W** buttons instead.



- Make sure that the camcorder and wireless controller are set to the same mode. Display the camcorder's mode by pressing any button on the wireless controller (except the REMOTE SET button) and set the wireless controller's mode to the same mode. Change the batteries if the wireless controller still does not work.
- The wireless controller returns to mode 1 when you replace the batteries. Change the mode if necessary.

Selecting the Still Image Quality/Size

Changing the Still Image Quality

You can choose from Super fine, Fine and Normal.



* Only when playing back a tape.

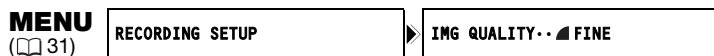

Open the menu and select **[RECORDING SETUP]**. Select **[IMG QUALITY]**, select a setting option and close the menu.

Changing the Still Image Size

Available image sizes will depend on the operating mode and the recording standard settings.

Recording still images in CAMERA·CARD mode	Simultaneous recording of a still image in CAMERA mode	Capturing a still image in VCR/PLAY mode
LW 1920x1080 SW 848x480	[HD] or [SD16:9]: LW 1920x1080 SW 848x480	From a recording made in [HD]: LW 1920x1080 SW 848x480
L 1440x1080 S 640x480	[SD4:3]: L 1440x1080 S 640x480	From a recording made in [SD16:9]: SW 848x480 From a recording made in [SD4:3]: S 640x480



* Only when playing back a tape.



Open the menu and select **[RECORDING SETUP]**. Select **[IMAGE SIZE]** (**[HD IMG SIZE]** in **VCR/PLAY** mode), select a setting option and close the menu.



Still images are recorded on the memory card using JPEG compression.

Number of still images that can be recorded on a memory card

Image size	Image quality	Memory card			File size per image
		16 MB	128 MB	512 MB	
LW 1920 x 1080	Super Fine	9	90	350	1360 kB
	Fine	14	135	525	910 kB
	Normal	28	265	1035	460 kB
SW 848 x 480	Super Fine	50	455	1770	280 kB
	Fine	70	645	2510	190 kB
	Normal	140	1295	5030	100 kB
L 1440 x 1080	Super Fine	12	120	470	1020 kB
	Fine	19	180	700	690 kB
	Normal	38	350	1370	350 kB
S 640 x 480	Super Fine	65	595	2320	215 kB
	Fine	95	865	3350	149 kB
	Normal	170	1555	6035	82 kB

- These figures are approximate. They vary according to recording conditions and the subject.
- The total number of still images that can be recorded will decrease if you store custom preset files on the card.

File Numbers

Still images are automatically assigned file numbers from 0101 to 9900, and stored in folders containing up to 100 images. Folders are numbered from 101 to 998.

[RESET]: Image numbers will restart from 101-0101 every time you insert a new memory card.

[CONTINUOUS]: Image numbers will continue from the number following that of the last image recorded with the camcorder. If the memory card you insert already contains an image with a larger number, a new image will be assigned a number one higher than that of the last image on the memory card. There will be no duplication of file numbers. This is useful for organizing images on a computer.



* Only when playing back a tape.

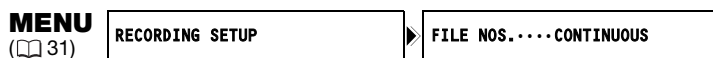

To change the setting, open the menu and select [RECORDING SETUP]. Select [FILE NOS.], select a setting option and close the menu.

Recording Still Images on a Memory Card

You can record still images directly on the memory card. You can also record still images on the memory card simultaneously while recording video on the tape and capture still images while playing back a tape.

Using a lens specially designed for HDV recording is required to be able to record still images. As of March 2008, only the following lenses can be used to record still images: HD 6x L, HD 20x L IS II and HD 20x L IS III.

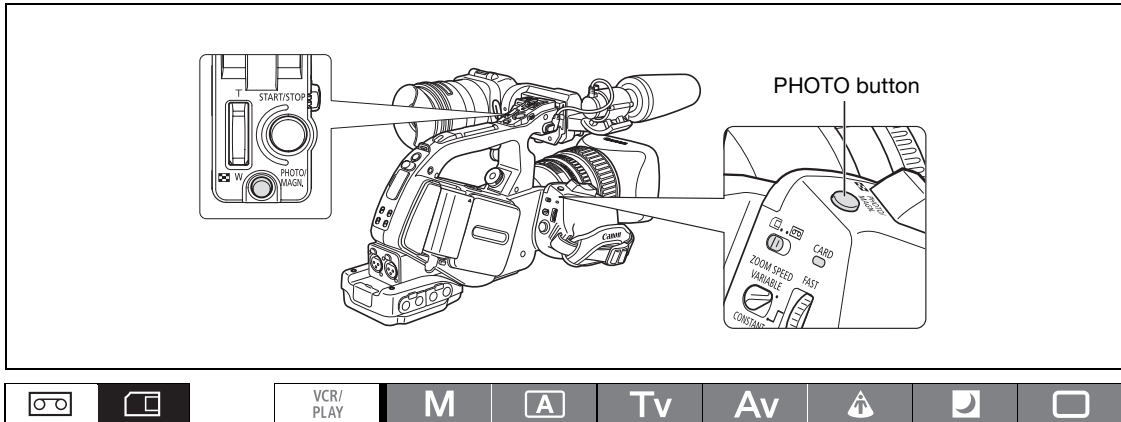

1. Turn the **POWER** dial to a recording program and set the (card/tape) switch to .

2. Press the **PHOTO** button halfway.

- turns green once the focus is adjusted and exposure is locked. The picture may appear out of focus for a moment while the camcorder is focusing.
- While the PHOTO button is half-pressed you can also use the focus ring to adjust the focus.
- When you press the PHOTO button on the wireless controller, the still image is recorded immediately.

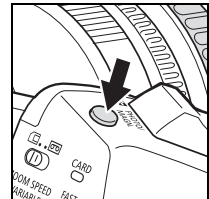

3. Press the **PHOTO** button fully.

- disappears.
- The CARD access indicator flashes and the card access display appears.

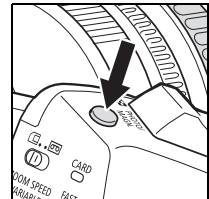

- When you are using an SDHC or SD memory card, make sure that the protect switch is set to allow recording. If you attempt to record a still image on a write-protected memory card the message “THE CARD IS SET FOR ERASURE PREVENTION” will be displayed.
- Observe the following precautions while the card access display () appears on the screen or the CARD access indicator is on or flashing. Failing to do so may result in permanent data loss.
 - Do not remove the memory card.
 - Do not change the position of the (card/tape) switch or the **POWER** dial.
 - Do not turn off the camcorder, remove the battery pack or disconnect the power supply.



○ If [CAMERA SETUP] ► [FOCUS PRI.] is set to [ON]:

When you press the PHOTO button fully, before ● turns green, it may take up to 2 seconds (4 seconds in Night mode) until the focus is adjusted.

If the subject is not suitable for autofocus, the camcorder locks the focus. In that case, adjust the focus manually with the focus ring.

○ If [CAMERA SETUP] ► [FOCUS PRI.] is set to [OFF]:

In step 2, ● turns green and the focus and exposure are locked.

○ About the Power Save function:

In [CAMERA CARD] mode: In order to save power when the camcorder is powered with a battery pack, the camcorder will automatically enter the power save mode if you do not operate it for 5 minutes. You can turn off the power save function with the [SYSTEM SETUP] ► [POWER SAVE] setting (132). To resume recording if the camcorder shut off automatically because of the power save function, press the STANDBY button or turn the [POWER] dial to OFF and then back to a recording mode.

Recording a Still Image on a Memory Card While Recording Movies on a Tape

With the custom function [PHOTO BUTTON] (100) you can select to activate the simultaneous recording of a still image while recording movies on the tape. If you select [PHOTO + CP DATA] you can also save the custom preset settings currently in use embedded within the still image. This is very useful when you want to read the custom preset file later by selecting the still image captured from a specific scene.



1. Activate the simultaneous recording of still images with the custom function [PHOTO BUTTON] (104).

2. While you are recording the movie, press the PHOTO button.



○ Simultaneous still images cannot be recorded while a fader is in use.

○ [OFF] appears if you press the PHOTO button when the custom function [PHOTO BUTTON] is set to [OFF].

Capturing a Still Image from a Tape

With the custom function [PHOTO BUTTON] (100) you can select to activate the capturing of a still image during playback pause.



1. Activate the capturing of still images with the custom function [PHOTO BUTTON] (104).

2. In playback pause, press the PHOTO button to record the frame as a still image on the memory card.



○ Still images cannot be captured from a tape when [SIGNAL SETUP] ► [LETTERBOX] is set to [ON].

Screen Displays during Still Image Recording

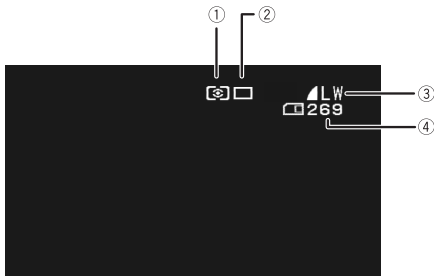

① Metering Mode Icon (121)

Indicates the metering mode currently selected for recording still images.

② Drive Mode Icon (120)

Indicates the drive mode currently selected for recording still images.

③ Image Quality and Size

Indicates the quality and size currently selected for recording still images.

④ Remaining Number of Still Images that can be Recorded on the Memory Card

- flashing in red: No card
- in green: 6 or more images
- in yellow: 1 to 5 images
- in red: No more images

- The indication may not decrease even though a recording has been made, or may decrease by 2 images at once.

- All indicators are displayed in green when a memory card is played back.

“▶” Card Access Display

Indicates that the camcorder is writing on the memory card.

Reviewing a Still Image right after Recording

You can select to display a still image for 2, 4, 6, 8 or 10 seconds after it has been recorded.

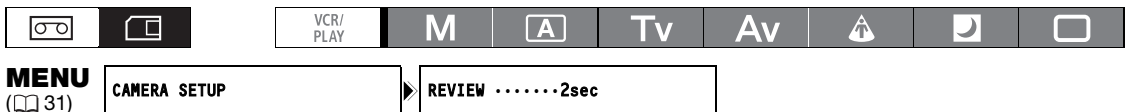

Open the menu and select [CAMERA SETUP]. Select [REVIEW], select a setting option and close the menu.



- Regardless of the [REVIEW] setting, a still image is displayed as long as you hold the PHOTO button after recording.
- The still image operations menu appears when you press the SET button while you are reviewing a still image or right after recording one. In this menu, you can protect (126) or erase (125) the image.
- The [REVIEW] setting is only available when the drive mode is set to (single).

Drive Mode

Drive mode	Use
Continuous Shooting	Captures a quick series of still images while you hold the PHOTO button pressed down. For the number of shots per second, refer to the table below.
High-Speed Continuous	
AEB (Auto Exposure Bracketing)	The camcorder records a still image in three different exposures (dark, normal, light in 1/2 EV steps).
Single	Records a single still image when you press the PHOTO button.



Changing the Drive Mode

1. Set the **POWER** dial to a recording program other than and move the (card/ tape) switch to .

2. Press the **DRIVE MODE** button to switch between the drive modes.

Pressing the button will cycle through the drive modes. The icon of the selected drive mode will appear on the screen.

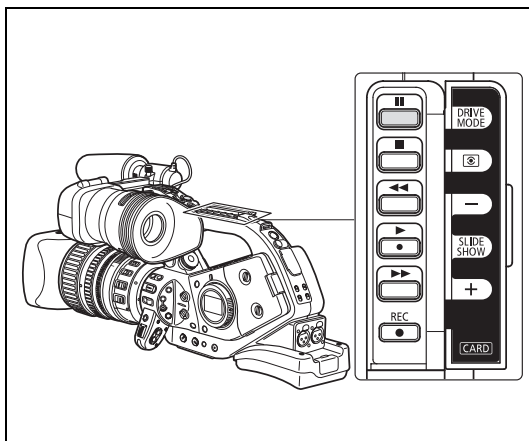

Continuous Shooting/High-Speed Continuous Shooting

Press and hold the **PHOTO** button.

A series of still images will be recorded as long as you hold the PHOTO button pressed down.



Maximum number of continuous shots:

Shots per second		Maximum number of continuous shots
Normal speed	High speed	
2.5 images	4.1 images	60 images

- These figures are approximate and vary depending on the recording conditions and subject.
- Sufficient space on the memory card is required. Continuous shooting will stop when the card is full.

Auto Exposure Bracketing

Press the **PHOTO** button.

Three still images in different exposures are recorded on the memory card. Make sure that there is sufficient space on the memory card.

Metering Mode

Metering mode	Use
<input checked="" type="checkbox"/> Evaluative	Appropriate for standard shooting conditions, including backlit scenes. The camcorder divides images into several metering zones. It evaluates the position and brightness of the subject, background, direct light or backlight, and adjusts the exposure of the main subject accordingly.
<input type="checkbox"/> Center-weighted average	Averages the light metered from the entire screen, giving more weight to the subject in the center.
<input checked="" type="checkbox"/> Spot AE	Meters the area within the Spot AE frame.



1. Set the **POWER** dial to **A**, **Tv**, **Av** or **M**, and set the (card/tape) switch to .

2. Press the button.

- Pressing the button will cycle through the metering modes. The icon of the selected metering mode will appear on the screen.
- If you selected Spot AE, the Spot AE frame appears in the center of the screen.

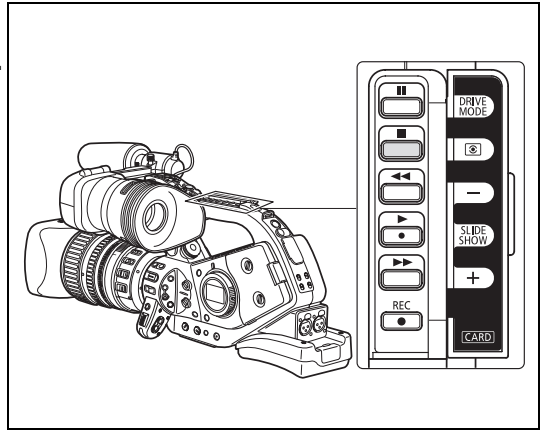

Using an Optional Flash

You can use E-TTL II-compatible Canon Speedlite flashes designed for use with Canon SLR cameras, including the 420EX/430EX/550EX/580EX/580EX II models, to record natural still images under low light conditions. Refer also to the instruction manual of the Speedlite flash.

The following procedures are explained using a Canon 580EX II Speedlite Flash.

Connecting a Speedlite Flash

When connecting a Canon Speedlite flash you cannot use the Off-Camera Shoe Cord designed for Canon EOS SLR cameras.

Always turn off the camcorder when connecting or removing the flash.

1. Slip the flash's mounting foot all the way into the camcorder's hot shoe.
2. Slide the lock lever on the mounting foot to the right until it clicks in place.



To remove the flash:

Press and hold the lock-release button and slide the lock lever to the left and then remove the flash from the hot shoe.

Using the Flash



1. Set the **POWER** dial to a recording mode other than **M** and turn on the flash.

- While the Speedlite flash is charging, the  indicator will flash in white. Once charged, the  indicator will stay on in green.
- If the  indicator keeps flashing in white for a long time, replace the flash's batteries.



2. Press the **PHOTO** button to record a still image.





- Wait until the flash is charged before recording the still image. You can record a still image while the flash is charging, but the flash will not go off.
- Turn off the Speedlite flash when you are not using it.
- The flash will not go off during exposure lock and in the **M** Manual mode.
- While using the flash, the shutter speeds that can be set in **Tv** mode are 1/4 – 1/500.
- The camcorder does not support the Bounce Flash function or the Wireless Multiple Flash System function of the Speedlite 420EX/430EX/550EX/580EX/580EX II flashes.
- The camcorder does not support the ST-E2 Wireless Speedlite Flash Transmitter or the Wireless Master/Slave Control function of the Speedlite 420EX/430EX/550EX/580EX/580EX II flashes.
- When recording under very dark conditions, as you keep the PHOTO button pressed halfway, the AF assist lamp of the Speedlite flash may light up (only when recording using autofocus and with [CAMERA SETUP] ► [FOCUS PRI.] set to [ON]).
- The Speedlite flash will not go off when the drive mode is set to  Auto Exposure Bracketing.

Playing Back Still Images from a Memory Card

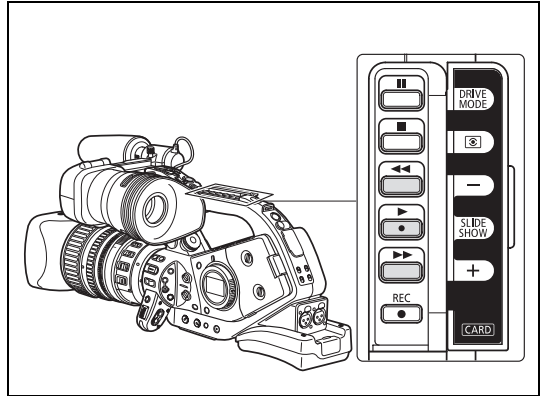

1. Turn the **POWER** dial to **VCR/PLAY** and set the  /  (card/tape) switch to .
2. Press the **CARD** + or – button to move between images.



- Still images not recorded with this camcorder, uploaded from a computer, edited on a computer and still images whose file names have been changed, may not be played back correctly.
- Observe the following precautions while the card access display appears on the screen or the CARD access indicator is on or flashing. Failing to do so may result in permanent data loss.
 - Do not remove the memory card.
 - Do not change the position of the  /  (card/tape) switch or the **POWER** dial.
 - Do not turn off the camcorder, remove the battery pack or disconnect the power supply.

Slideshow

Press the **SLIDESHOW** button.

- Still images are played back one after another.
- Press the button again to stop the slideshow.

Index Screen

1. Move the zoom lever toward **W**.

Up to 6 still images appear.

2. Turn the **SELECT** dial to select an image.

- Move  to the still image you wish to view.
- You can switch between index pages by pressing the **CARD** + or – button.

3. Move the zoom lever toward **T** or press the **SET** button.

The selected still image is displayed.

Image Jump Function

You can locate still images without displaying them one by one. The number in the upper right of the screen indicates the number of the current still image out of the total number of still images.

Press and hold the **CARD + or – button.**

When you release the button, the still image corresponding to the number that appears on the screen is displayed.

Displaying the Recording Data

You can select whether to display all the recording data stored when the still image was recorded (histogram, Exif camera information, etc.).

Repeatedly press the EVF DISPLAY button to display the recording data.

Erasing Still images

You can erase still images one at a time or all at once.



- Be careful when erasing still images. Erased still images cannot be recovered.
- Erasing a still image that had a custom preset file embedded (recorded with the [PHOTO + CP DATA] setting) will erase the still image and the embedded custom preset file.



Protected still images (🔒 126) cannot be erased.

Erasing a Single Still Image

1. Select the still image you wish to erase.
2. Press the SET button to open the still image operations menu.
In **CAMERA CARD** mode, the menu appears when you press the SET button while you are reviewing a still image, or immediately after recording a still image.
3. Select **[IMAGE ERASE]**.
4. Select **[ERASE]**.
The image is erased and the previous image appears.
5. Select **[↩CLOSE]** to close the menu.

Erasing All Images



1. Open the menu and select **[CARD OPERATIONS]**.
2. Select **[ERASE ALL IMAGES]**.
3. Select **[YES]** and close the menu.
All still images except the protected ones are erased.

Protecting Still images

You can protect important still images from accidental erasure when displaying a single image or the index screen.



If a memory card is initialized, all still images, even protected ones, will be erased permanently.

Protecting a Single Still Image

1. Select the still image you wish to protect.
2. Press the SET button to open the still image operations menu.
In **CAMERA·CARD** mode, the menu appears when you press the SET button while you are reviewing a still image, or immediately after recording a still image.
3. Select [**OFF** PROTECT].
4. Select [**ON**].
To remove the protection select [OFF] instead.
5. Select [**↵**CLOSE] to close the menu.
ON appears and now the image cannot be erased.

Protecting Still Images from the Index Screen

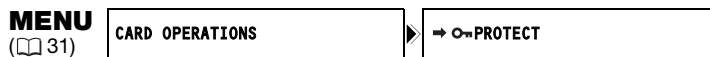

1. Move the zoom lever toward **W**.
Up to 6 still images appear.
2. Open the menu and select [**CARD OPERATIONS**]. Select [**⇒ ON-PROTECT**] and press the SET button.
3. Select the image you wish to protect and press the SET button.
 - **ON** appears on the image.
 - Select additional images with the SELECT dial and protect them in the same way.
4. Close the menu to return to the index screen.

Initializing a Memory Card

Initialize new memory cards, or when you get the message “CARD ERROR”. You can also initialize a memory card to erase all data recorded on it. The regular initialization option [INITIALIZE] will clear the file allocation table but will not physically erase the stored data. If you need to completely erase all the data, select instead the complete initialization option [COMPL.INIT.].



- Initializing a memory card erases all data, including protected still images and custom preset files.
- Still images and custom preset files erased as a result of initializing the card cannot be recovered.
- We recommend using the [COMPL.INIT.] option when you feel that the time it takes to record an image on or read an image from the memory card has become too long.
- Depending on the memory card, the complete initialization may take up to a few minutes.
- If you use a memory card other than the supplied one, initialize it with the camcorder.

MENU
(31)



1. Open the menu and select [CARD OPERATIONS].
2. Select [INITIALIZE] and select the initialization method.
3. [INITIALIZE]: Select [YES].
[COMPL.INIT.]: Select [YES] and, in the confirmation screen, select [YES] again.
 - The card initialization starts.
 - The complete initialization can be canceled while still in progress by pressing the SET button. All the image files will be erased and the memory card can be used without any problem.

Print Order Settings

You can select still images for printing and set the number of copies. These print order settings are compatible with the Digital Print Order Format (DPOF) standards and can be used for printing on DPOF-compatible printers. A maximum of 998 still images can be selected.



Selecting Still Images for Printing (Print Order)

1. Select the still image you wish to print.
2. Press the **SET** button to open the still image operations menu.
3. Select [**PRINT ORDER**].
4. Select the number of copies.
To cancel the print order, set the number of copies to 0.
5. Select [**CLOSE**] to close the menu.

Setting Print Orders from the Index Screen

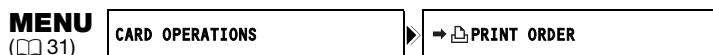

1. Move the zoom lever toward **W**.
Up to 6 still images appear.
2. Open the menu, select [**CARD OPERATIONS**] and select [**PRINT ORDER**].
3. Select the still image you wish to print and press the **SET** button.
4. Set the number of copies with the **SELECT** dial and press the **SET** button.
 - appears on the image.
 - To cancel the print order, set the number of copies to 0.
5. Close the menu to return to the index screen.

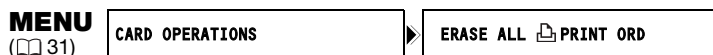

Erasing All Print Orders









1. Open the menu and select [**CARD OPERATIONS**].
2. Select [**ERASE ALL PRINT ORD**] and select [**YES**].
All disappear.
3. Close the menu.

Menu Options and Default Settings

In the following tables, default settings are shown in boldface and the availability of menu settings in different operating modes is indicated with the following icons:

CAMERA: CAMERA MENU (**POWER** dial set to one of the recording modes, / switch set to )

VCR/PLAY: VCR/PLAY MENU (**POWER** dial set to , / switch is set to )

CAMERA-CARD: CARD CAMERA MENU (**POWER** dial set to one of the recording modes, / switch set to )

VCR/PLAY-CARD: CARD PLAY MENU (**POWER** dial set to , / switch set to )

■ SIGNAL SETUP

Menu item	(Submenu item and)	Setting options	CAMERA	VCR/PLAY	CAMERA-CARD	VCR/PLAY-CARD	
TIME CODE	COUNT-UP	REC-RUN , REC-RUN PS., FREE-RUN	●	●	–	–	49
	START VALUE	00:00:00:00 (SET, RESET)	●	●	–	–	49
	HDV/DV IN	REGEN. , COPY	–	●	–	–	89
GENLCK ADJUST ¹	0000 (-1023 to 1023)		●	–	●	–	50
PLAYBACK STD	AUTO , HDV, DV		–	●	–	–	110
COMP.OUT	576i, 1080i/576i		●	●	●	●	83
SDI OUTPUT ¹	ON(OSD), ON, OFF		●	●	●	●	82
SDI SPEC. ¹	AUTO , SD LOCKED		●	●	●	●	82
AV → DV	ON, OFF		–	●	–	–	90
HD DOWN-CONV	ON, OFF		–	●	–	–	83
LETTERBOX	ON, OFF		–	●	–	–	81

¹ **EXTRA** only.







[HD DOWN-CONV]: Selects whether to down-convert the video signal output from the HDV/DV terminal while playing back a tape recorded in HDV standard.

Standard of the tape being played back	[HD DOWN-CONV] Setting	[PLAYBACK STD] Setting		
		[AUTO]	[HDV]	[DV]
HDV	[ON]	DV	DV	No output
	[OFF]	HDV	HDV	No output
DV	[ON]	DV	No output	DV
	[OFF]	DV	No output	DV



○The down-converted output video signal will always be 50i, regardless of the frame rate of the original recording.

○Even if the audio was originally recorded using all 4 channels (with another camcorder), only channels 1 and 2 will be output.

■ CAMERA SETUP

Menu item	(Submenu item and) Setting options	CAMERA	VCR/PLAY	CAMERA-CARD	VCR/PLAY-CARD		
AGC LIMIT	OFF(18dB) , 15dB, 12dB, 9dB, 6dB, 3dB	●	–	●	–	66	
SKIN DETAIL	EFFECT LEVEL	●	–	●	–	72	
							OFF , LOW  , MIDDLE  , HIGH 
	HUE						0 (-6 to 6)
	CHROMA						0 (-6 to 6)
	AREA						0 (-6 to 6)
	Y LEVEL	0 (-6 to 6)					
SELECTIVE NR	EFFECT LEVEL	●	–	●	–	73	
							OFF , LOW  , MIDDLE  , HIGH 
	HUE						0 (-6 to 6)
	CHROMA						0 (-6 to 6)
	AREA						0 (-6 to 6)
	Y LEVEL	0 (-6 to 6)					
COLOR CORR.	CORRECT	●	–	●	–	70	
	A AREA SEL., B AREA SEL.						COLOR PHASE: 0 (0 to 15)
							CHROMA: 0 (-6 to 6)
							AREA: 3 (1 to 4)
							Y LEVEL: 0 (-6 to 6)
	A AREA REV., B AREA REV.	R GAIN: 0 (-6 to 6)					
		B GAIN: 0 (-6 to 6)					
F SPEED PSET	4 (4 to 1)	●	–	●	–	45	
CLEAR SCAN	50.2Hz (50.2Hz to 200.3Hz)	●	–	–	–	74	
FB	➔ AF ADJUST, ➔ MF ADJUST, SET DEFAULT	●	–	●	–	26	
FOCUS PRI.	ON , OFF	–	–	●	–	117	
REVIEW	OFF, 2sec , 4sec, 6sec, 8sec, 10sec	–	–	●	–	119	
FOCUS LIMIT	ON  , OFF	●	–	●	–	46	

■ RECORDING SETUP

Menu item	Setting options	CAMERA	VCR/PLAY	CAMERA-CARD	VCR/PLAY-CARD	
DV REC MODE	SP , LP	● ¹	●	–	–	107
UB REC	INT.USR-BIT , EXT.USR-BIT	●	–	–	–	52
UB SELECT	00 00 00 00 , TIME, DATE	●	●	–	–	52
IMG QUALITY	 SUPER FINE,  FINE ,  NORMAL	●	●	●	–	115
IMAGE SIZE	MODE SELECT switch at HD or SD 16:9: LW 1920x1080 , SW 848X480	●	–	–	–	115
	MODE SELECT switch at SD 4:3: L 1440x1080 , S 640X480	–	–	●	–	
HD IMG SIZE	LW 1920x1080 , SW 848X480	–	●	–	–	118
FILE NOS.	RESET, CONTINUOUS	●	●	●	–	116

¹ Available only when recording in standard definition (SD).

[DV REC MODE]: When recording in standard definition (SD mode) only, you can choose between SP (standard play) and LP (long play). LP extends the tape usage by 1.5 times.

- Depending on the tape and its usage condition, picture and sound recorded in LP mode may be distorted. We recommend using SP mode for important recordings.
- If you record in both SP and LP modes on the same tape, the playback picture may become distorted, and the time code may not be written correctly.
- If you play back on this camcorder, a tape that was recorded in LP mode with another digital device or vice versa, the picture and sound may become distorted.

■ AUDIO SETUP

Menu item	Setting options	CAMERA	VCR/PLAY	CAMERA-CARD	VCR/PLAY-CARD	
AUD.M.SET	CH 1/2 , CH 3/4 , MIX/FIXED, MIX/VAR.	–	●	–	–	55
MIX BALANCE	1/2 ————— 3/4	–	●	–	–	86
DV AUDIO	16bit , 12bit	● ¹	●	–	–	53
MONITOR SEL.	NORMAL , LINE OUT	●	–	–	–	86
WIND SCREEN	ON , OFF	●	–	●	–	53
MIC SENSIT.	NORMAL , HIGH	●	–	●	–	53
XLR 1 TRIM	+12dB, +6dB, 0dB , -6dB, -12dB	●	–	●	–	55
XLR 2 TRIM						
OUTPUT LEVEL	1Vrms , 2Vrms	●	●	●	–	86
XLR ALC LINK	LINK, SEP	●	–	●	–	55
AUD.LIMITER	ON, OFF	●	–	●	–	55

¹ Available only when recording in standard definition (SD).



[OUTPUT LEVEL]: Select the amplitude of the audio output signal.

■ CARD OPERATIONS

Menu item	Setting options	CAMERA	VCR/PLAY	CAMERA-CARD	VCR/PLAY-CARD	
ERASE ALL PRINT ORD	NO , YES	–	–	–	●	128
ERASE ALL IMAGES	NO , YES	–	–	–	●	125
INITIALIZE	CANCEL , INITIALIZE, COMPL.INIT.	–	–	–	●	127
After opening the menu from the index screen:						
⇒ PROTECT	–	–	–	–	●	126
⇒ PRINT ORDER	–	–	–	–	●	128
After pressing the SET button:						
IMAGE ERASE	CANCEL , ERASE	–	–	● ¹	●	125
PROTECT	OFF, ON	–	–	● ¹	●	126
PRINT ORDER	0 COPIES	–	–	–	●	128
SLIDESHOW	CANCEL , START	–	–	–	●	123

¹ Available only when you press the SET button within the time set for the [CAMERA SETUP] ▶ [REVIEW] setting (or immediately after recording if it is set to [OFF]).

■ DISPLAY SETUP/

Menu item	(Submenu item and) Setting options	CAMERA	VCR/PLAY	CAMERA - CARD	VCR/PLAY - CARD		
EVF SETUP	EVF BW MODE	ON, OFF	●	●	●	●	22
	BRIGHTNESS	0 (-23 to 22)					
	CONTRAST	0 (-23 to 22)					
	COLOR	0 (-3 to 3)					
	SHARPNESS	2 (1 to 4)					
PEAKING SETUP	PEAKING1	GAIN: 8 (OFF to 15)	●	–	●	–	44
		FREQUENCY: 2 (1 to 4)					
	PEAKING2	GAIN: 15 (OFF to 15)					
		FREQUENCY: 1 (1 to 4)					
LANGUAGE 	DEUTSCH, ENGLISH , ESPAÑOL, FRANÇAIS, ITALIANO, POLSKI, РУССКИЙ, 简体中文, 日本語	●	●	●	●	33	
MARKERS	OFF , LEVEL MARK., CENT.MARK., GRID MARKER	●	–	●	–	–	
ASPECT GUIDE	OFF , 4:3, 13:9, 14:9, 1.66:1, 1.75:1, 1.85:1, 2.35:1	●	–	–	–	–	
SAFETY ZONE	OFF , 80%, 90%	●	–	–	–	–	
ZEBRA	ON, OFF	●	–	●	–	69	
ZEBRA LEVEL	70, 75, 80, 85 , 90, 95, 100	●	–	●	–	69	
TV SCREEN ¹	ON , OFF	●	●	●	●	76	
AUDIO LEVEL	ON , OFF	●	●	–	–	55	
GUIDE INFO	OFF , CUSTOM KEYS, D/T DISPLAY	●	–	●	–	37	
CUSTOM KEY	ON, OFF	–	●	–	●	75	
DATA CODE	DATE, TIME, DATE & TIME , CAMERA DATA, CAM.& D/T	–	●	–	–	113	
6SEC.DATE	ON, OFF	–	●	–	–	113	
UB DISPLAY	ON, OFF	●	●	–	–	52	

¹ In playback modes the default setting is [OFF].

[MARKERS]: You can display the on-screen markers to help you accurately frame your subject. Select from a center marker, a horizontal level marker or a grid. You can also adjust the intensity of the markers display ( 105).

[ASPECT GUIDE]: Use the aspect ratio guides as a reference to accurately frame subjects. You can select to display the aspect guides for 4:3, 13:9, 14:9, 1.66:1, 1.75:1, 1.85:1 or 2.35:1 (Cinemascope).

[SAFETY ZONE]: The safety zone guide shows a frame including 80% or 90% of the screen area. Use it as a reference to accurately frame subjects.

■ SYSTEM SETUP/

Menu item	(Submenu item and) Setting options	CAMERA	VCR/PLAY	CAMERA - CARD	VCR/PLAY - CARD	
CUSTOM KEY1	TIME CODE , INDEX WRITE, ZEBRA, VCR STOP, TV SCREEN, TC HOLD, AUDIO LEVEL, EVF BW MODE, MAGN.B.LOCK, SHTR B.LOCK, AE D.LOCK, E.LCK B.LCK, FB, FLIP EVF, SDI OUTPUT ¹ , FOCUS LIMIT, (NONE)	●	–	–	–	75
	TIME CODE, TV SCREEN , DATA CODE, AUDIO LEVEL, TC HOLD, EVF BW MODE, SDI OUTPUT ¹ , (NONE)	–	●	–	–	75
	ZEBRA , TV SCREEN, EVF BW MODE, MAGN.B.LOCK, SHTR B.LOCK, AE D.LOCK, E.LCK B.LCK, FB, FLIP EVF, SDI OUTPUT ¹ , FOCUS LIMIT, (NONE)	–	–	●	–	75
	TV SCREEN , EVF BW MODE, SDI OUTPUT ¹ , (NONE)	–	–	–	●	75

■ SYSTEM SETUP/☑ (cont.)

Menu item	(Submenu item and) Setting options	CAMERA	VCR/PLAY	CAMERA - CARD	VCR/PLAY - CARD		
CUSTOM KEY2	TIME CODE, INDEX WRITE , ZEBRA, VCR STOP, TV SCREEN, TC HOLD, AUDIO LEVEL, EVF BW MODE, MAGN.B.LOCK, SHTR B.LOCK, AE D.LOCK, E.LCK B.LCK, CP BKWD KEY, FB, FLIP EVF, SDI OUTPUT ¹ , FOCUS LIMIT, (NONE)	●	–	–	–	75	
	TIME CODE, TV SCREEN, DATA CODE , AUDIO LEVEL, TC HOLD, EVF BW MODE, SDI OUTPUT ¹ , (NONE)	–	●	–	–	75	
	ZEBRA, TV SCREEN , EVF BW MODE, MAGN.B.LOCK, SHTR B.LOCK, AE D.LOCK, E.LCK B.LCK, CP BKWD KEY, FB, FLIP EVF, SDI OUTPUT ¹ , FOCUS LIMIT, (NONE)	–	–	●	–	75	
	TV SCREEN, EVF BW MODE , SDI OUTPUT ¹ , (NONE)	–	–	–	●	75	
POWER SAVE	ON , OFF	●	–	●	–	35	
D/TIME SET ☑	T.ZONE/DST	●	●	●	●	32	
	DATE/TIME						–
	DATE FORMAT						YMD (2008.1.1 AM12:00), MDY (JAN.1.2008 12:00AM) DMY (1.JAN.2008 12:00AM)
DV CONTROL	ON DV  , OFF	●	–	–	–	88	
MAGN.B.LOCK	DISABLED , ACTIVE	●	–	●	–	44	
SHTR B.LOCK	DISABLED , ACTIVE	●	–	●	–	63	
AE D.LOCK	DISABLED , ACTIVE	●	–	●	–	65	
E.LCK B.LCK	DISABLED , ACTIVE	●	–	●	–	65	
ALL DISPLAY	ENABLE , DISABLE	●	–	●	–	37	
RESET ALL	NO , YES	●	●	●	●	146	
CAM.F.VER.	Current version of the camcorder's firmware.	–	–	–	●	–	
LENS F.VER.	Current version of the lens' firmware.	–	–	–	●	–	

¹ **EXT-1TB** only.

■ CUSTOMIZE

Menu item	Submenu item	CAMERA	VCR/PLAY	CAMERA - CARD	VCR/PLAY - CARD	
CUSTOM PRESET	EDIT	●	–	●	–	92
	CAMERA → CARD					
	CARD → CAMERA					
	← RETURN					
META DATA CP	CARD → CAMERA	–	–	–	●	92
	← RETURN					
CUSTOM FUNCTION ¹	C.Fn1	●	●	●	●	100
	C.Fn2					
	C.Fn3					
	← RETURN					
CUSTOM DISPLAY	Refer to the table on page 136.	●	–	●	–	106

¹ In **(VCR/PLAY)** mode, this will appear on the main menu and not under the [CUSTOMIZE] menu.

■ Custom Preset Submenu (CUSTOMIZE ► CUSTOM PRESET)

Submenu item	Action	(Parameter and) Setting Options																																														
EDIT	SELECT CP	1 PRESET_A, 2 PRESET_B, 3 PRESET_C, 4 PRESET_D, 5 PRESET_E, 6 PRESET_F, 7 VIDEO.C, 8 CINE.V, 9 CINE.F																																														
	TUNE	<table border="1"> <tr> <td>[GAM] GAMMA*</td> <td>NORMAL, CINE1, CINE2</td> </tr> <tr> <td>[KNE] KNEE</td> <td>AUTO, LOW, MIDDLE, HIGH</td> </tr> <tr> <td>[BLK] BLACK</td> <td>STRETCH, MIDDLE, PRESS</td> </tr> <tr> <td>[PED] MASTER PED. *</td> <td>0 (-9 to 9)</td> </tr> <tr> <td>[SET] SETUP LEVEL*</td> <td>0 (-9 to 9)</td> </tr> <tr> <td>[SHP] SHARPNESS</td> <td>0 (-9 to 9)</td> </tr> <tr> <td>[HDF] H DTL FREQ</td> <td>LOW, MIDDLE, HIGH</td> </tr> <tr> <td>[DHV] DTL HV BAL</td> <td>0 (-9 to 9)</td> </tr> <tr> <td>[COR] CORING</td> <td>0 (-9 to 9)</td> </tr> <tr> <td>[NR1] NR1*</td> <td>OFF, LOW, MIDDLE, HIGH</td> </tr> <tr> <td>[NR2] NR2*</td> <td>OFF, LOW, MIDDLE, HIGH</td> </tr> <tr> <td>[CMX] COLOR MAT. *</td> <td>NORMAL, CINE1, CINE2</td> </tr> <tr> <td>[CGN] COLOR GAIN</td> <td>0 (-50 to 50)</td> </tr> <tr> <td>[CPH] COLOR PHASE</td> <td>0 (-9 to 9)</td> </tr> <tr> <td>[RGN] R GAIN</td> <td>0 (-50 to 50)</td> </tr> <tr> <td>[GGN] G GAIN</td> <td>0 (-50 to 50)</td> </tr> <tr> <td>[BGN] B GAIN</td> <td>0 (-50 to 50)</td> </tr> <tr> <td>[RGM] RG MATRIX</td> <td>0 (-50 to 50)</td> </tr> <tr> <td>[RBM] RB MATRIX</td> <td>0 (-50 to 50)</td> </tr> <tr> <td>[GRM] GR MATRIX</td> <td>0 (-50 to 50)</td> </tr> <tr> <td>[GBM] GB MATRIX</td> <td>0 (-50 to 50)</td> </tr> <tr> <td>[BRM] BR MATRIX</td> <td>0 (-50 to 50)</td> </tr> <tr> <td>[BGM] BG MATRIX</td> <td>0 (-50 to 50)</td> </tr> </table>	[GAM] GAMMA*	NORMAL , CINE1, CINE2	[KNE] KNEE	AUTO, LOW, MIDDLE , HIGH	[BLK] BLACK	STRETCH, MIDDLE , PRESS	[PED] MASTER PED. *	0 (-9 to 9)	[SET] SETUP LEVEL*	0 (-9 to 9)	[SHP] SHARPNESS	0 (-9 to 9)	[HDF] H DTL FREQ	LOW, MIDDLE , HIGH	[DHV] DTL HV BAL	0 (-9 to 9)	[COR] CORING	0 (-9 to 9)	[NR1] NR1*	OFF , LOW, MIDDLE, HIGH	[NR2] NR2*	OFF , LOW, MIDDLE, HIGH	[CMX] COLOR MAT. *	NORMAL , CINE1, CINE2	[CGN] COLOR GAIN	0 (-50 to 50)	[CPH] COLOR PHASE	0 (-9 to 9)	[RGN] R GAIN	0 (-50 to 50)	[GGN] G GAIN	0 (-50 to 50)	[BGN] B GAIN	0 (-50 to 50)	[RGM] RG MATRIX	0 (-50 to 50)	[RBM] RB MATRIX	0 (-50 to 50)	[GRM] GR MATRIX	0 (-50 to 50)	[GBM] GB MATRIX	0 (-50 to 50)	[BRM] BR MATRIX	0 (-50 to 50)	[BGM] BG MATRIX	0 (-50 to 50)
	[GAM] GAMMA*	NORMAL , CINE1, CINE2																																														
	[KNE] KNEE	AUTO, LOW, MIDDLE , HIGH																																														
	[BLK] BLACK	STRETCH, MIDDLE , PRESS																																														
	[PED] MASTER PED. *	0 (-9 to 9)																																														
	[SET] SETUP LEVEL*	0 (-9 to 9)																																														
	[SHP] SHARPNESS	0 (-9 to 9)																																														
	[HDF] H DTL FREQ	LOW, MIDDLE , HIGH																																														
	[DHV] DTL HV BAL	0 (-9 to 9)																																														
	[COR] CORING	0 (-9 to 9)																																														
	[NR1] NR1*	OFF , LOW, MIDDLE, HIGH																																														
	[NR2] NR2*	OFF , LOW, MIDDLE, HIGH																																														
	[CMX] COLOR MAT. *	NORMAL , CINE1, CINE2																																														
	[CGN] COLOR GAIN	0 (-50 to 50)																																														
	[CPH] COLOR PHASE	0 (-9 to 9)																																														
	[RGN] R GAIN	0 (-50 to 50)																																														
	[GGN] G GAIN	0 (-50 to 50)																																														
	[BGN] B GAIN	0 (-50 to 50)																																														
	[RGM] RG MATRIX	0 (-50 to 50)																																														
	[RBM] RB MATRIX	0 (-50 to 50)																																														
	[GRM] GR MATRIX	0 (-50 to 50)																																														
	[GBM] GB MATRIX	0 (-50 to 50)																																														
	[BRM] BR MATRIX	0 (-50 to 50)																																														
	[BGM] BG MATRIX	0 (-50 to 50)																																														
	RENAME	–																																														
	PROTECT	–																																														
RESET	CANCEL, EXECUTE																																															
CAMERA ⇒ CARD	SELECT CP	1 PRESET_A, 2 PRESET_B, 3 PRESET_C, 4 PRESET_D, 5 PRESET_E, 6 PRESET_F, 7 VIDEO.C, 8 CINE.V, 9 CINE.F																																														
	SAVE POSITION	–																																														
	EXECUTE	CANCEL, EXECUTE																																														
CARD ⇒ CAMERA	IMPORT	–																																														
	SELECT POSITION	1 PRESET_A, 2 PRESET_B, 3 PRESET_C, 4 PRESET_D, 5 PRESET_E, 6 PRESET_F, 7 VIDEO.C, 8 CINE.V, 9 CINE.F																																														
	EXECUTE	CANCEL, EXECUTE																																														

* Available only when recording movies.

■ Custom Function Submenu (CUSTOMIZE ► CUSTOM FUNCTION)

Submenu item	Action	(Custom Function and)	Setting Options
C.Fn1, C.Fn2, C.Fn3	APPLY THIS SET	DISABLED, ACTIVE	
	TUNE	00 SHCKLESS WB/GN	00 (00 to 03)
		01 ZOOM RING CTRL	00 NORMAL , 01 SLOW, 02 FAST
		02 ZOOM SPEED	00 NORMAL , 01 SLOW, 02 FAST
		03 FOCUS RING CTRL	00 NORMAL , 01 SLOW, 02 FAST
		04 BUTTONS OPER.1	00 (00 to 03)
		05 BUTTONS OPER.2	00 (00 to 15)
		06 RINGS DIRECTION	00 (00 to 07)
		07 OPER.DIRECTION	00 (00 to 03)
		08 IRIS LIMIT	00 OFF , 01 ON
		09 PHOTO BUTTON	00 PHOTO + CP DATA , 01 PHOTO, 02 MAGNIFYING, 03 OFF
		10 MARKER LEVEL	00 (00 to 07)
		11 F.AST BW-MOD	00 (00 to 03)
		12 OBJ DST UNIT	00 m(meter) , 01 ft(feet)
		13 ZOOM INDICATOR	00 BAR , 01 NUMBER
		14 COLOR BARS	00 TYPE 1 , 01 TYPE 2
		15 1kHz TONE	00 OFF , 01 -12dB, 02 -18dB, 03 -20dB
		16 WIRELESS REMOTE	00 1, 01 2, 02 OFF
		17 LANC AE SHIFT	00 AE SHIFT , 01 IRIS
		18 TALLY LAMP	00 ON , 01 BLINK, 02 OFF
		19 LED	00 TYPE 1 , 01 TYPE 2, 02 OFF
		20 CUSTOM REC	00 (00 to 03)
		SAVE TO CARD	CANCEL, OK
	READ FROM CARD	CANCEL, OK	
	RESET	CANCEL, OK	

■ Custom Displays

Menu item	Action	(Custom Display and)	Setting Options
CUSTOM DISPLAY	TUNE	00 REC PROGRAMS	00 OFF, 01 ON
		01 CAMERA DATA1	03 (00 to 03)
		02 CAMERA DATA2	07 (00 to 07)
		03 ZOOM	00 OFF, 01 ON(NORMAL) , 02 ON(ALWAYS)
		04 FOCUS	00 OFF, 01 ON(NORMAL) , 02 ON(ALWAYS)
		05 ND	00 OFF, 01 ON
		06 IMAGE EFFECTS	07 (00 to 07)
		07 F.ASSIST FUNC.	03 (00 to 03)
		08 CUSTOMIZE	03 (00 to 03)
		09 RECORDING STD	00 OFF, 01 ON
		10 DV REC MODE	00 OFF , 01 ON
		11 FRAME RATE	00 OFF, 01 ON
		12 TAPE	03 (00 to 07)
		13 TAPE REMAINDER	00 OFF, 01 NORMAL, 02 WARNING
		14 TAPE/CARD	02 (00 to 07)
		15 LIGHT METERING	03 (00 to 03)
		16 CARD	03 (00 to 03)
		17 CARD REMAINDER	00 OFF, 01 NORMAL, 02 WARNING
		18 AUDIO	00 (00 to 07)
		19 WARNING/STATUS	15 (00 to 15)
		20 BATTERY	00 OFF, 01 NORMAL, 02 WARNING
		21 WIRELESS REMOTE	00 OFF, 01 NORMAL, 02 WARNING
		SAVE TO CARD	CANCEL, OK
READ FROM CARD	CANCEL, OK		
RESET	CANCEL, OK		

Settings Memorized and Retained

The following lists show the settings that are memorized and retained under different circumstances like turning off the camcorder, setting it to standby or changing operating modes. If the built-in lithium button battery discharges completely, all settings will be erased.

CAMERA / CAMERA · CARD Modes	Power Off	STANDBY Mode	Changing between HD and SD*
Shutter speed setting in Tv mode		●	
Aperture setting in Av mode		●	
Aperture, shutter speed setting in M Manual mode		●	
Custom white balance		●	
Exposure lock	Returns to off		●
Aperture, shutter speed setting during exposure lock	Reset		●
Color bars setting*	Reset		●
Color bars on/off*	Reset		●
Faders setting*	Reset		●
Faders on/off*		Reset	●
CAMERA , CAMERA · CARD MENU settings		●	
TV SCREEN on/off		●	
On-screen display settings		●	
EVF display	Returns to normal display		●
Side panel light	Returns to off		●
Gain fine tuning		●	
Gain limit		●	
Iris limit		●	

CAMERA / CAMERA · CARD Modes	Changing from <input type="checkbox"/> Easy Recording to other programmed AE mode	Changing the programmed AE mode to <input type="checkbox"/> Easy Recording	Changing the frame rate*
Shutter speed setting in Tv mode		●	
Aperture setting in Av mode		●	
Aperture, shutter speed setting in M Manual mode		●	
Custom white balance		●	
Exposure lock		Returns to off	
Aperture, shutter speed setting during exposure lock		Reset	
Color bars setting*		●	
Color bars on/off*		●	
Faders setting*	●	Reset	●
Faders on/off*	●	Reset	●
CAMERA , CAMERA · CARD MENU settings		●	
TV SCREEN on/off		●	
On-screen display settings		●	
EVF display		●	
Side panel light		●	
Gain fine tuning		●	
Gain limit		●	
Iris limit		●	

* **CAMERA** mode only.

Screen Displays

Screen Displays during Recording

You can find additional explanations on pages 36 and 119. Most of the on-screen displays and icons can be customized using the custom displays (106).

CAMERA

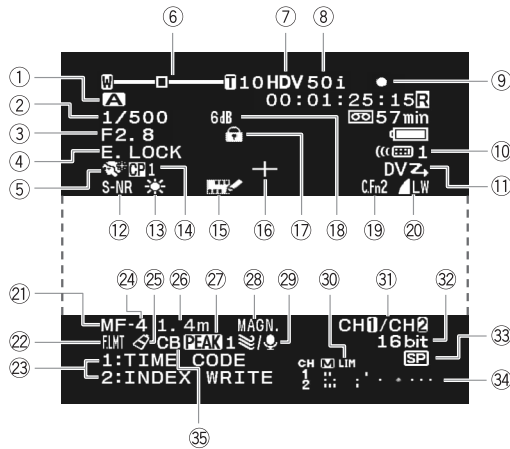

CAMERA · CARD

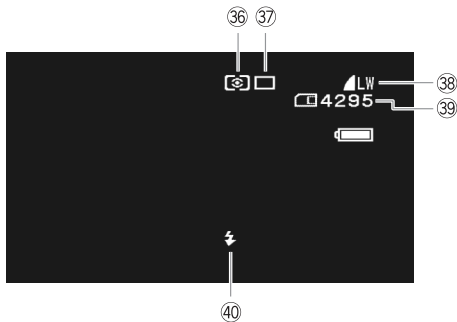

- ① Programmed AE (158)
- ② Shutter speed* (63, 61)
- ③ Aperture* (64, 61)
- ④ Exposure lock (65)/ AE shift (65)
- ⑤ Skin detail (72)
- ⑥ Zoom position/Zoom speed (40)/ Exposure level (61)
- ⑦ Recording standard (38)
- ⑧ Frame rate (48)
- ⑨ Tape operation
 - Recording
 - || Record pause
 - Stop
 - ▲ Eject
- ⑩ Remote sensor mode (114)
- ⑪ DV control (88)
- ⑫ Selective noise reduction (73)
- ⑬ White balance (67)
- ⑭ Custom preset file (92)
- ⑮ Superimposed character recording (105)
- ⑯ Center marker (132)
- ⑰ Button/dial used is locked
- ⑱ Gain (66)
- ⑲ Custom function (100)
- ⑳ Still image size/quality (simultaneous recording) (115)
- ㉑ Manual focus (43)
- ㉒ Focus limit (46)
- ㉓ Custom keys (75)/ Date and time (32)
- ㉔ Focus preset speed (45)
- ㉕ Color correction (70)
- ㉖ Focusing distance (43)
- ㉗ Peaking (44)
- ㉘ Magnifying (44)
- ㉙ Wind screen (53)
- ㉚ Audio peak limiter (55)
- ㉛ Audio output (86)
- ㉜ (SD) Audio mode (53)
- ㉝ (SD) Recording mode (130)
- ㉞ Audio level indicator (55)
- ㉟ Color bars (79)
- ㊱ Metering mode (121)
- ㊲ Drive mode (120)
- ㊳ Still image size/quality (115)
- ㊴ Available still images on the card (115)
- ㊵ Flash (122)

* In **M** Manual mode.

Screen Displays during Playback

VCR/PLAY

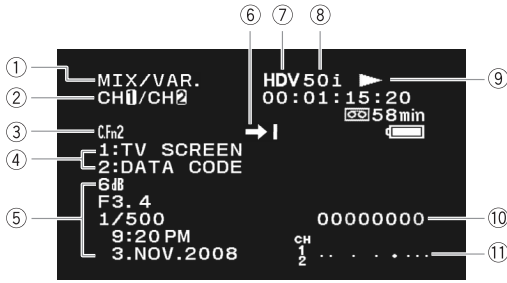

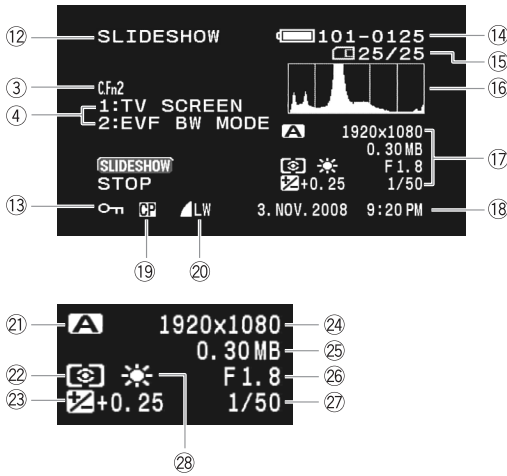

VCR/PLAY · CARD

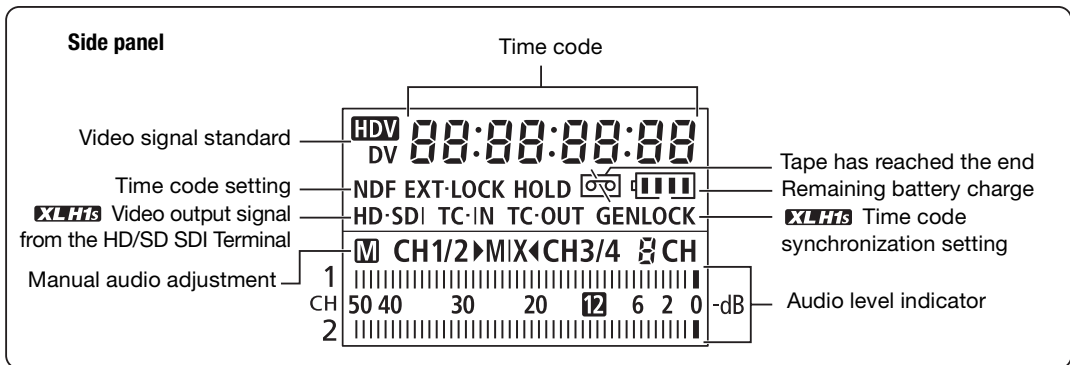

- ① Audio monitor (86)
- ② Audio output (86)
- ③ Custom function (100)
- ④ Custom keys (75)
- ⑤ Data code (113)
- ⑥ Date search (113)/ Index search (112)/ End search (39)
- ⑦ Recording standard (38)
- ⑧ Frame rate (48)
- ⑨ Tape operation (110)
 - Recording
 - || Record pause
 - Stop
 - ▲ Eject
 - ▶ Playback
 - ▶|| : Playback pause
 - ▶▶ : Fast forward
 - ◀◀ : Rewind
 - ◀▶/▶◀ : Fast forward playback/rewind playback
 - ×2▶/◀×2 : Playback (double speed)
 - ×1▶/◀×1 : Playback (normal speed)
 - ▶/◀ : Frame advance/reverse
- ⑩ User bit (52)
- ⑪ Audio level indicator (55)
- ⑫ Slideshow (123)
- ⑬ Image protected (126)
- ⑭ Image number (116)
- ⑮ Current image/total number of still images (115)
- ⑯ Histogram (124)
- ⑰ Exif information icons (124)
- ⑱ Date and time of recording
- ⑲ Custom preset data embedded with the still image (95)
- ⑳ Still image quality/size
- ㉑ Programmed AE (58)
- ㉒ Metering mode (121)
- ㉓ AE shift (65)
- ㉔ Still image size (115)
- ㉕ File size
- ㉖ Aperture (61, 64)
- ㉗ Shutter speed (61, 63)
- ㉘ White balance (67)



List of Messages (in alphabetical order)

Message	Explanation	
CARD ERROR	A memory card error occurred. The camcorder cannot record or play back the image. The error may be temporary. If the message disappears after 4 seconds and  flashes in red, turn the camcorder off, remove the card and reinsert the card. If  changes to green, you can continue recording/playback.	–
CARD FULL	No remaining capacity on the memory card. Replace with another card or erase images.	–
CHANGE THE BATTERY PACK	Battery pack is exhausted. Replace or charge the battery pack.	15
CHECK THE HDV/DV INPUT	DV cable is not connected, or the connected digital device is turned off.	89
CHECK THE LENS	Lens is not correctly mounted. Turn the lens until it clicks. If the message does not disappear, unmount and remount the lens.	–
CONDENSATION HAS BEEN DETECTED	Condensation has been detected in the camcorder.	144
COPYRIGHT PROTECTED DUBBING RESTRICTED	You attempted to dub a copyright protected tape. May also appear when an anomalous signal is received during analog line-in recording, or during analog-digital conversion of a copyright protected tape.	90
COPYRIGHT PROTECTED PLAYBACK IS RESTRICTED	You attempted to play back a copyright protected tape.	90
ENTERING "POWER STANDBY"	Appears for 1 second when you press the STANDBY button.	–
HD INCOMPATIBLE LENS	You mounted a lens that does not support HDV recording.	
HEADS DIRTY, USE CLEANING CASSETTE	Video heads are dirty. Clean the video heads.	144
INCORRECT TAPE SPECIFICATION PLAYBACK IS RESTRICTED	You attempted to play back a tape recorded in a standard different than the one to which is the camcorder is set.	–
INPUT SIGNAL NOT SUPPORTED	You attempted to input a video signal incompatible with the camcorder (for example 720p).	89
NAMING ERROR	The folder and file numbers have reached their maximum value.	–
NO CARD	Memory card not inserted into the camcorder.	30
NO IMAGES	No images are recorded on the memory card.	–
PLAYBACK STD LOCKED INCOMPATIBLE VIDEO INPUT	When the playback standard is already set in the camcorder, you attempted to input a video signal in a standard different from that set.	89
PLAYBACK STD LOCKED PLAYBACK IS RESTRICTED	When the playback standard is already set in the camcorder, you attempted to play back a tape in a video standard different from that set.	110
REMOVE THE CASSETTE	Camcorder stopped operating to protect the tape. Remove the cassette and reinsert it.	29
SET THE TIME ZONE, DATE AND TIME	You have not set the time zone, date and time. This message appears each time you turn the power on until you set the time zone, date and time.	32
TAPE END	Tape reached the end. Rewind the tape or replace the cassette.	–
THE CARD IS SET FOR ERASURE PREVENTION	SD/SDHC memory card is set for erasure prevention. Replace the card or change the position of the LOCK switch.	30
THE MEMORY CARD COVER IS OPEN	Close the memory card cover.	
THE TAPE IS SET FOR ERASURE PREVENTION	Cassette is protected. Replace the cassette or change the position of the protect switch.	143
THIS LENS HAS NO STILL SHOOTING CAPABILITY	You mounted a lens that does not support still image recording.	
UNIDENTIFIABLE IMAGE	Image is not recorded with JPEG compression, or with a compression not compatible with the camcorder, or the image file is corrupted.	–

Maintenance/Others

Camcorder Handling Precautions

- Do not carry the camcorder by the viewfinder, the microphone or its cable.
- Do not leave the camcorder in places subject to high temperatures, such as a sun-heated car, and high humidity.
- Do not use the camcorder in places subject to strong electromagnetic fields such as near TV sets, plasma TVs, radio transmitters or portable communication devices.
- Do not point the lens or viewfinder at strong light sources. Do not leave the camcorder pointed at a bright subject.
- Do not use the camcorder in dusty or sandy places. Dust or sand getting inside the cassette or camcorder may cause damage. Dust and sand can also damage the lens. Attach the lens cap after use.
- The camcorder is not waterproof. Water, mud or salt getting inside the cassette or camcorder may cause damage.
- Be careful of heat generated by lighting equipment.
- Do not disassemble the camcorder. If the camcorder does not function properly, consult qualified service personnel.
- Handle the camcorder with care. Do not subject the camcorder to shocks or vibration as this may cause damage.
- Avoid sudden changes in temperature. Moving the camcorder rapidly between hot and cold temperatures may cause condensation to form on its internal surfaces (144).

Storage

- If you do not intend to use the camcorder for a long time, store it in a place free of dust, with low humidity, and at temperatures not higher than 30 °C.
- Before using the camcorder after a long storage period, check the functions of your camcorder to make sure that the camcorder is still working properly.

Cleaning

Camcorder Body and Lens

- Use a soft, dry cloth to clean the camcorder body and lens. Never use chemically treated cloth or volatile solvents such as paint thinner.

LCD Screen

- Clean the LCD screen using a commercially available lens cleaning cloth.
- Condensation may form on the surface of the screen when the temperature changes suddenly. Wipe it with a soft dry cloth.

Viewfinder

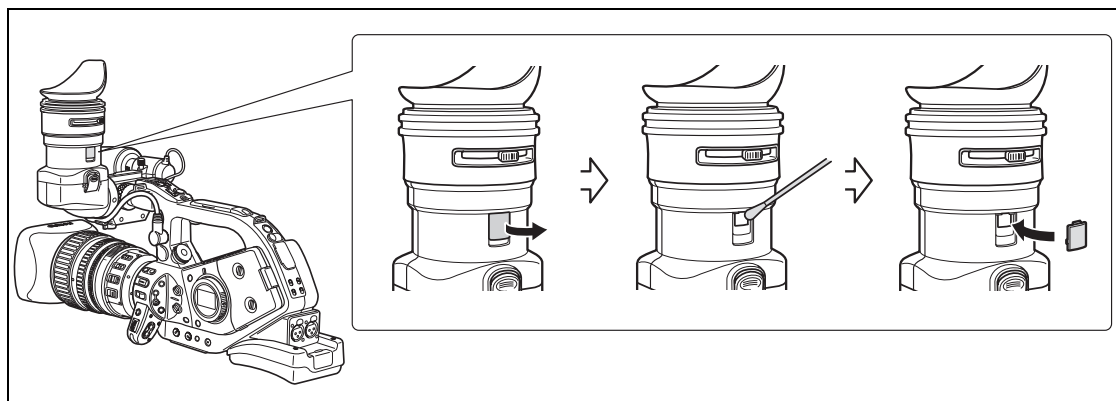

1. Open the protecting cover (e.g. using a flathead screwdriver).
2. Clean the glass with a cotton swab.
3. Reattach the protecting cover.



Be careful not to scratch the glass when cleaning it.

Battery Pack Handling Precautions

DANGER!

Treat the battery pack with care.

- Keep it away from fire (or it might explode).
- Do not expose the battery pack to temperature higher than 60 °C. Do not leave it near a heater or inside a car in hot weather.
- Do not try to disassemble or modify it.
- Do not drop or knock it.
- Do not get it wet.

- Charged battery packs continue to discharge naturally. Therefore, charge them on the day of use, or the day before, to ensure a full charge.
- Attach the terminal cover whenever a battery pack is not in use. Contact with metallic objects may cause a short circuit and damage the battery pack.
- Dirty terminals may cause a poor contact between the battery pack and the camcorder. Wipe the terminals with a soft cloth.
- Since storing a charged battery pack for a long time (about 1 year) can shorten its lifecycle or affect performance, we recommend to discharge the battery pack fully and to store it in a dry place at temperatures no higher than 30 °C. If you do not use the battery pack for long periods, charge and discharge it fully at least once a year. If you have more than one battery pack, perform these precautions at the same time for all battery packs.
- Although the battery pack's operating temperature range is from 0 °C to 40 °C, the optimal range is from 10 °C to 30 °C. At cold temperatures, performance will temporarily decline. Warm it in your pocket before use.
- Replace the battery pack if the usable time after full charge diminishes substantially at normal temperatures.

About the battery terminal cover

The battery terminal cover has a [□]-shaped hole. This is useful when you wish to differentiate between charged and uncharged battery packs. For example, with charged battery packs, attach the terminal cover so that the [□]-shaped hole shows the blue label.

Back side of the battery pack

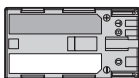

Terminal cover attached
Charged



Uncharged



Cassette Handling Precautions

- Rewind tapes after use. If the tape is loose or damaged, it may cause picture and sound distortion.
- Return cassettes to their case and store them upright. Rewind tapes from time to time if they are stored for a long time.
- Do not leave the cassette in the camcorder after use.
- Do not use spliced tapes or nonstandard cassettes as they may damage the camcorder.
- Do not use tapes that have been jammed as video heads may become dirty.
- Do not insert anything into the small holes of the cassette, or cover them with cellophane tape.
- Handle cassettes with care. Do not drop or subject them to severe impact as this may damage the cassettes.
- With cassettes equipped with a memory function, metal plated terminals may become dirty with use. Clean the terminals with a cotton swab after about 10 times of loading/unloading. The memory function is not supported by the camcorder.

Protecting Tapes from Accidental Erasure

To protect your recordings from accidental erasure, slide the tab on the cassette to the left. (This switch position is usually labeled SAVE or ERASE OFF.)

If you load a protected cassette in recording mode, the message “THE TAPE IS SET FOR ERASURE PREVENTION” appears for approx. 4 seconds and  starts flashing. If you wish to record on that cassette, slide the tab back to the right.

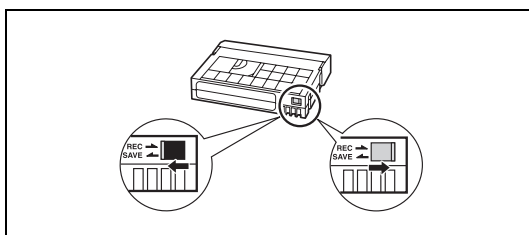

Memory Card

- To transfer the still images recorded on the memory disc to a computer, use a commercially available card reader or PC/PCMCIA memory card adapter.
- Initialize new memory cards with the camcorder. Memory cards initialized with other devices such as a computer may not operate correctly.
- We recommend backing up memory card images to your computer's hard drive or other external memory device. Image data may be corrupted or lost due to memory card defects or exposure to static electricity. Canon makes no warranties for corrupted or lost data.
- Do not use memory cards in places subject to strong magnetic fields.
- Do not leave memory cards in places subject to high humidity or high temperature.
- Do not disassemble memory cards.
- Do not bend, drop, or subject memory cards to shocks and do not expose them to water.
- Moving a memory card rapidly between hot and cold temperatures may cause condensation to form on its external and internal surfaces. If condensation forms on the card, put it aside until the droplets have evaporated completely.
- Do not touch or expose the terminals to dust or dirt.
- Check the direction before inserting the memory card. Forcing a memory card backwards into the slot may damage the memory card or the camcorder.
- Do not remove the label from the memory card, or attach other labels to the memory card.
- When you erase image files or initialize the memory card, only the file allocation table is altered and the data itself is not actually deleted. Take the necessary precautions when you dispose of the memory card, for example by physically damaging it to prevent the leakage of private data.
- SD/SDHC memory cards have a physical switch to prevent writing on the card so as to avoid the accidental erasure of the card's content. To write-protect the memory card set the switch to the LOCK position.



Built-in Rechargeable Lithium Battery

The camcorder has a built-in rechargeable lithium battery to keep the date/time and other settings. The built-in lithium battery is recharged while you use the camcorder; however, it will become totally discharged if you do not use the camcorder for about 3 months.

To recharge the built-in lithium battery:

Connect the compact power adapter to the camcorder and leave it connected for 24 hours with the camcorder off.

Video Heads

- When the message “HEADS DIRTY, USE CLEANING CASSETTE” appears, when the playback picture becomes distorted, or if during playback of a tape recorded in HDV standard the picture and/or sound stops momentarily (about 0.5 seconds) the video heads need to be cleaned.
- To maintain the best picture quality, we recommend cleaning the video heads frequently with the Canon DVM-CL Digital Video Head Cleaning Cassette or a commercially available dry cleaning cassette.
- Tapes already recorded with dirty video heads may not be played back correctly even after cleaning the video heads.
- Do not use wet type cleaning cassettes as this may damage the camcorder.
- If the playback picture does not improve after cleaning the video heads it may indicate a malfunction. Consult a Canon Service Center.



Condensation

Moving the camcorder rapidly between hot and cold temperatures may cause condensation (water droplets) to form on its internal surfaces. Stop using the camcorder if condensation is detected. Continued use may damage the camcorder.



Condensation may form in the following cases:

- When the camcorder is moved from an air-conditioned room to a warm, humid place
- When the camcorder is moved from a cold place to a warm room
- When the camcorder is left in a humid room
- When a cold room is heated rapidly

How to avoid condensation:

- Unload the cassette, place the camcorder in an airtight plastic bag and let it adjust to temperature changes slowly before removing it from the bag.

When condensation is detected:

- The camcorder stops operating, and the warning message “CONDENSATION HAS BEEN DETECTED” appears for approx. 4 seconds and  starts flashing.
- If a cassette is loaded, the warning message “CONDENSATION HAS BEEN DETECTED REMOVE THE CASSETTE” appears and  starts flashing. Remove the cassette immediately and leave the cassette compartment open. Leaving the cassette in the camcorder may damage the tape.
- A cassette cannot be loaded when condensation is detected.

Resuming use:

○It takes about 1 hour until the water droplets evaporate. After the condensation warning stops flashing, wait for 1 more hour before resuming use.

Using the Camcorder Abroad

Power Sources

You can use the compact power adapter to operate the camcorder and to charge battery packs in any country with power supply between 100 and 240 V AC, 50/60 Hz. Consult a Canon Service Center for information on plug adapters for overseas use.

Playback on a TV Screen

You can only play back your recordings on TVs compatible with the PAL system. The PAL system is used in the following countries/areas:

Algeria, Australia, Austria, Bangladesh, Belgium, Brunei, China, Croatia, Czech Republic, Denmark, Finland, Germany, Hong Kong Special Administrative Region, Iceland, India, Indonesia, Iran, Iraq, Ireland, Israel, Italy, Jordan, Kenya, Kuwait, Liberia, Malaysia, Malta, Montenegro, Mozambique, the Netherlands, New Zealand, North Korea, Norway, Oman, Pakistan, Poland, Portugal, Qatar, Romania, Serbia, Sierra Leone, Singapore, Slovakia, Slovenia, South Africa, Spain, Sri Lanka, Swaziland, Sweden, Switzerland, Tanzania, Thailand, Turkey, Uganda, Ukraine, United Arab Emirates, United Kingdom, Yemen, Zambia.

Troubleshooting

If you have a problem with your camcorder, refer to this checklist. Consult your dealer or a Canon Service Center if the problem persists.

Power Source

Problem	Cause	Solution	📖
Camcorder will not turn on.	Battery pack is not correctly attached.	Attach the battery pack correctly.	15
The camcorder switches off by itself.	Power save function has been activated.	Turn on the camcorder.	35
The screen switches on and off.	Battery pack is exhausted.	Replace or charge the battery pack.	15

Recording/Playback

Problem	Cause	Solution	📖
Buttons will not work.	Cassette is not loaded.	Load a cassette.	29
🔊 flashes on the screen.	Condensation is detected.	See reference page.	144
“REMOVE THE CASSETTE” appears on the screen.	Camcorder stopped operating to protect the tape.	Remove the cassette and reinsert it.	29
The wireless controller will not work.	Camcorder and wireless controller are not set to the same remote sensor mode.	Change the remote sensor mode.	114
	Batteries of the wireless controller are exhausted.	Replace the batteries.	28
Abnormal characters appear on the screen. The camcorder does not operate properly.	This camcorder uses a microcomputer. External noise or static electricity may cause abnormal characters to appear on the screen.	Disconnect the power source and reconnect it after a short time. If the problem still persists, disconnect the power source and press the RESET button with a pointed item. Pressing the RESET button resets all settings. You can also reset all the camcorder's settings to default values using the [SYSTEM SETUP/👍] ▶ [RESET ALL] setting.	–

Recording

Problem	Cause	Solution	📖
The POWER dial is not in the OFF position but the POWER indicator is off.	The LED indicators option in the customized functions is set to [OFF].	Set the [LED] setting to one of the other types.	105
Image will not appear on the screen.	The POWER dial is not set to a recording program.	Set the POWER dial to a recording program.	34
“SET THE TIME ZONE, DATE AND TIME” appears on the screen.	Time zone, date and time are not set, or the built-in rechargeable lithium battery is exhausted.	Set the time zone, date and time. If necessary, power the camcorder with the compact power adapter and leave it connected with the POWER dial set to OFF for at least 24 hours to recharge the built-in battery before making the settings.	32
Pressing the Start/Stop button will not start recording.	Cassette is not loaded.	Load a cassette.	29
	The POWER dial is not set to a recording program.	Set the POWER dial to a recording program.	34
	The lock switch is set to prevent the operation of the controls on the carrying handle.	Slide the lock switch to the left to enable the operation of the carrying handle controls.	35
Camcorder will not focus.	Autofocus does not work on that subject.	Focus manually.	43
	Viewfinder is not adjusted.	Adjust the viewfinder with the dioptic adjustment lever.	21
	Lens is dirty.	Clean the lens.	141
The tally lamp will not light up.	The tally lamp option in the customized functions is set to [OFF].	Set the [TALLY LAMP] setting to [ON] or [BLINK].	105

Recording

Problem	Cause	Solution	
A vertical light bar appears on the screen.	Bright light in a dark scene may cause a vertical light bar (smear) to appear. This is not a malfunction.	Record in Av mode with an aperture value in the range F5.6–F8.0.	64
Viewfinder picture is blurred.	Viewfinder is not adjusted.	Adjust the viewfinder with the dioptic adjustment lever.	21
Audio is not recorded.	The input channel selection switch is not set to the correct position.	Set the INPUT SELECT switch to the correct position.	54
	Microphone connected to the XLR terminal needs to be powered by the phantom power.	Set the +48V switch to ON.	54
Audio is recorded in a very low level.	The REC LEVEL switch is set to M, and recording level is set too low.	Adjust the audio level correctly.	55
	Microphone attenuator is turned on.	Set the FRONT MIC ATT. switch or the XLR MIC ATT switch to OFF.	55

Playback

Problem	Cause	Solution	
Pressing the playback button does not start playback.	Camcorder is turned off, or is not set to VCR/PLAY mode.	Set the camcorder to VCR/PLAY mode.	110
	Cassette is not loaded.	Load a cassette.	29
Tape is running, but image will not appear on the TV screen.	Video heads are dirty.	Clean the video heads.	144
	You attempted to play back or dub a copyright protected tape.	Stop playback/dubbing.	–
	The video output cable is not connected correctly.	Verify that the video cable is connected properly.	–
While playing back a tape recorded in HDV standard there are brief stops in the playback picture.	Video heads are dirty.	Clean the video heads with a dry cleaning cassette.	144

Memory Card Operations

Problem	Cause	Solution	
Memory card cannot be inserted.	Memory card was not facing the correct direction.	Turn the memory card over and try inserting it again.	30
Memory card cannot be recorded.	No memory card.	Insert a memory card.	30
	Memory card is full.	Replace the memory card or erase images.	125
	Memory card is not initialized.	Initialize the memory card.	127
	The folder and file numbers have reached their maximum value.	Set [FILE NOS.] to [RESET] and insert a new memory card.	116
Memory card cannot be played back.	The POWER dial or (card/tape) switch are not set to the correct position.	Set the POWER dial to VCR/PLAY and the (card/tape) switch to .	123
Image cannot be erased.	Image is protected.	Cancel the protection.	143
	On an SDHC or SD memory card, the write-protect switch is set to the locked position.	Change the position of the write-protect switch on the memory card to unlock it.	
flashes red.	Card error occurred.	Turn off the camcorder. Remove and reinsert the memory card. Initialize the memory card if flashing persists.	127

Others

Lenses with built-in image stabilizer: Detected air bubbles inside the lens.	Sometimes air bubbles may form inside the lens in airplanes or on high mountains. This is not a malfunction. The air bubbles disappear in about 1 week.	–
------------------------------------------------------------------------------	---------------------------------------------------------------------------------------------------------------------------------------------------------	---

About the LCD screen

The LCD screen is produced with extremely high-precision manufacturing techniques, with more than 99.99% of the pixels operating to specification. Less than 0.01% of the pixels may occasionally misfire or appear as black, red, green or blue dots. This has no effect on the recorded image and does not constitute a malfunction.

System Diagram (Availability differs from area to area)

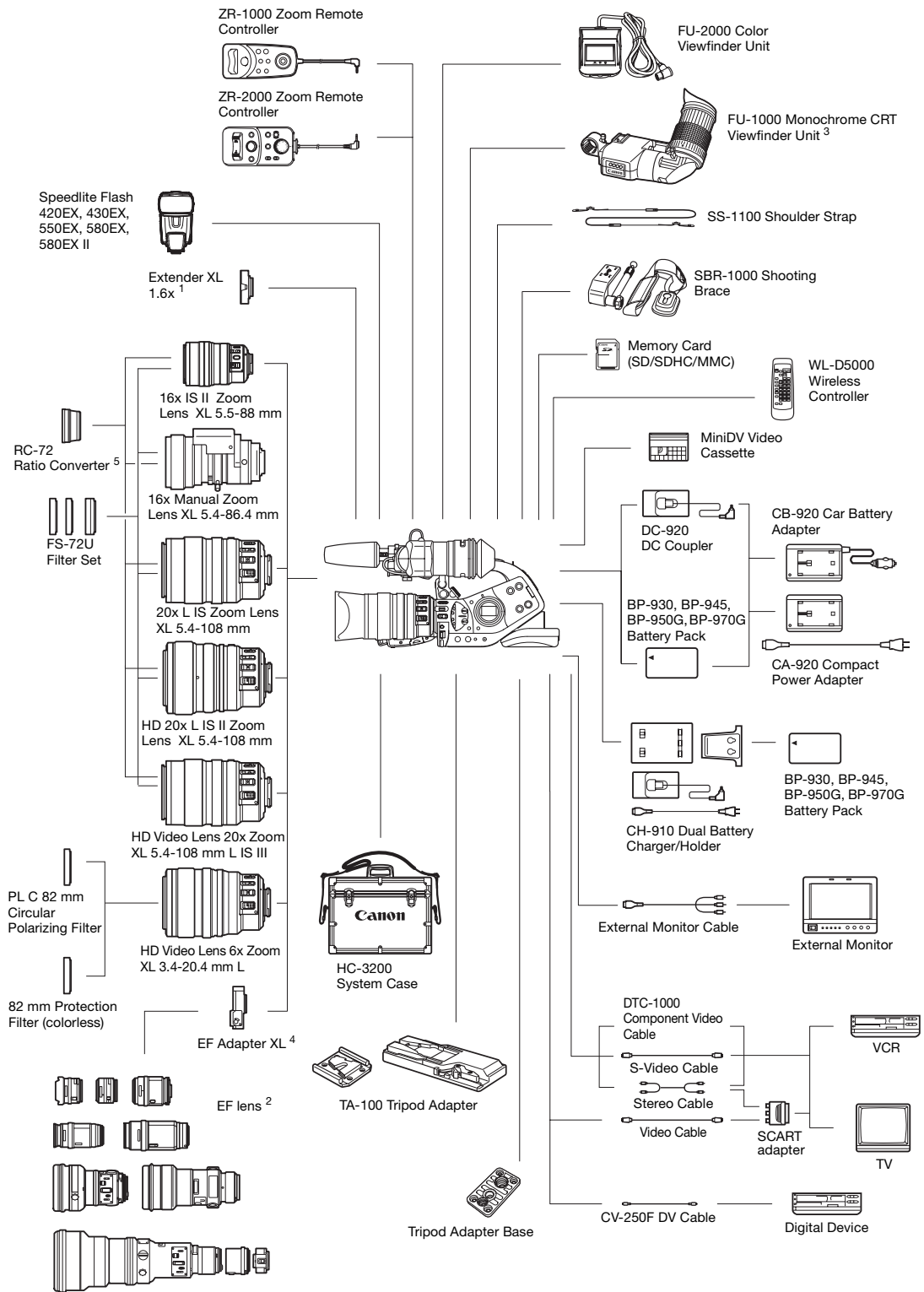

- ¹ Can be attached to the HD 20x L IS III, HD 20x L IS II, HD 6x L, 20x L IS, 16x IS II and 16x manual zoom lenses (only for recording in SD mode).
- ² EF-S lenses cannot be used.
- ³ When you use the FU-1000 Monochrome CRT Viewfinder with this camcorder you can use the compact power adapter or the optional CB-920 Car Battery Adapter as the power source. You cannot use the battery adapter supplied with the FU-1000; instead, connect the DC coupler directly to the camcorder and connect it to the compact power adapter or the car battery adapter.
Also, you cannot use the microphone protector supplied with the FU-1000 when using it with this camcorder.
- ⁴ When attaching EF lenses to the camcorder, the approximate 35 mm equivalent of the effective focal length is as follows: 4:3 - approx. 8.8x / 16:9 - approx. 7.2x.
- ⁵ Only when recording in SD 4:3 mode.

Optional Accessories

Use of genuine Canon accessories is recommended.

This product is designed to achieve excellent performance when used with genuine Canon accessories. Canon shall not be liable for any damage to this product and/or accidents such as fire, etc., caused by the malfunction of non-genuine Canon accessories (e.g., a leakage and/or explosion of a battery pack). Please note that this warranty does not apply to repairs arising out of the malfunction of non-genuine Canon accessories, although you may request such repairs on a chargeable basis.

Battery Packs

The BP-950G is also available as an optional accessory. The optional BP-970G provides over 35% more recording time than the BP-950G.

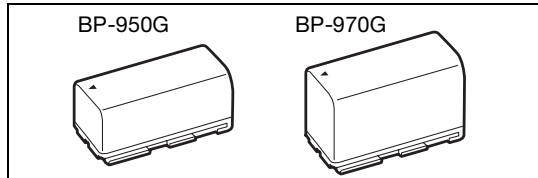

Car Battery Adapter CB-920

Use the car battery adapter to power the camcorder or charge battery packs on the move. The car battery adapter plugs into your car's cigarette lighter socket and runs off a 12-24V DC negative ground battery.

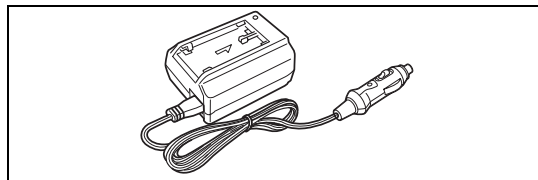

FS-72U Filter Set

Ultraviolet, neutral density and circular polarizing filters to help you take control of difficult lighting conditions.

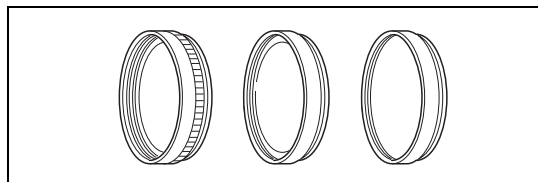

HC-3200 System Case

A solid, lockable case that provides safe and stylish protection for the camcorder during transportation and storage.



16x Manual Zoom Lens XL 5.4-86.4 mm

A high-resolution zoom lens with two zoom modes (manual and powered), built-in ND filter and AE functions.

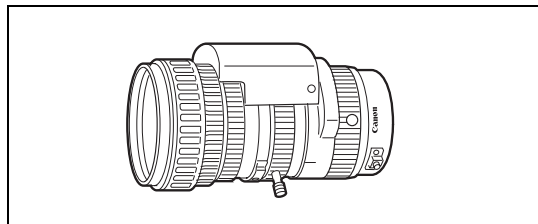

Extender XL 1.6x

Attach this extender between a Canon XL lens and the camcorder to boost the focal length of the lens by 1.6x.

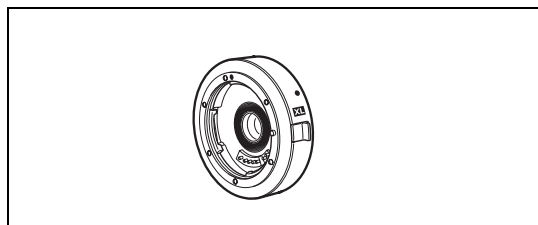

EF Adapter XL

This allows you to attach Canon EF lenses to the camcorder. The difference in size between the camcorder's 1/3-inch CCD's and 35 mm film means that the effective focal length of still camera lenses is multiplied by 8.8x (4:3)/7.2x (16:9).

- Consult your local service outlet to make sure there are no compatibility problems with your chosen lens.

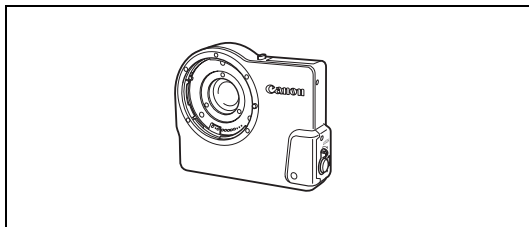

FU-1000 Monochrome CRT Viewfinder Unit

Professional quality B&W viewfinder with a 1.5-inch CRT.

- When you use the FU-1000 with this camcorder, you can supply power from the CA-920 or optional CB-920. The battery adapter supplied with the FU-1000 is not required. Attach the DC Coupler directly to the camcorder, and connect it with the CA-920/CB-920.

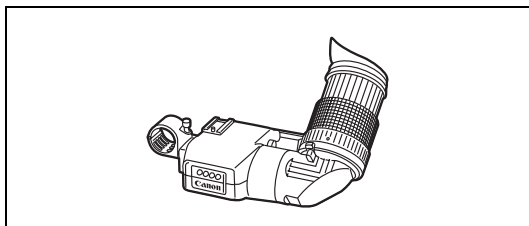

TA-100 Tripod Adapter

The TA-100 allows you to quickly mount/unmount the camcorder on/from a tripod.

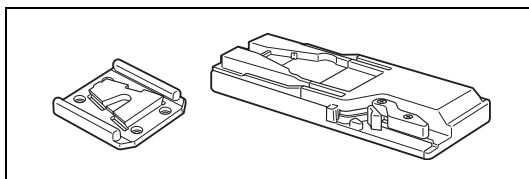

SBR-1000 Shooting Brace

Using the SBR-1000 for additional support of the camcorder with the neck strap will significantly lighten the load of the camera's weight while shooting.

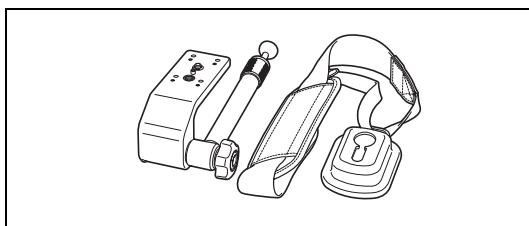

CH-910 Dual Battery Charger/Holder

The CH-910 can charge two battery packs consecutively. You can also power the camcorder by connecting the CH-910 with charged battery packs to the camcorder. When you attach two battery packs, a battery pack can be exchanged without interrupting the power supply.

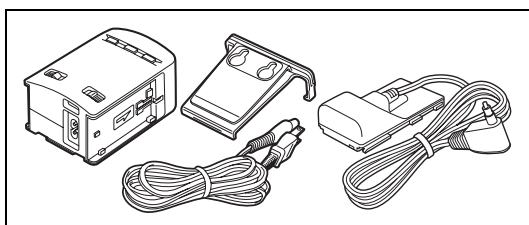

Battery Pack	Charging Time
BP-950G	280 min.
BP-970G	380 min.

Charging time varies according to the charging condition.

ZR-2000 Zoom Remote Controller

When the ZR-2000 is connected to the LANC  terminal of a Canon camcorder, it is possible to control functions such as the start and stop of recording, the zoom and the focus functions while reviewing the picture on the local display without touching the camcorder. This is particularly useful while the camcorder is mounted on a tripod and you want to ensure maximum stability of a shot.

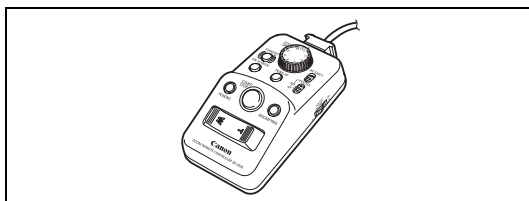

FU-2000 Color Viewfinder Unit

When the FU-2000 is connected to the color viewfinder socket of the camcorder, it is possible to review the on screen picture without having to be next to the camcorder. Also, by connecting the FU-2000 to the optional ZR-2000 Remote Zoom Controller you can have complete control of the main operations of the camcorder while reviewing the on-screen picture without touching the camcorder.

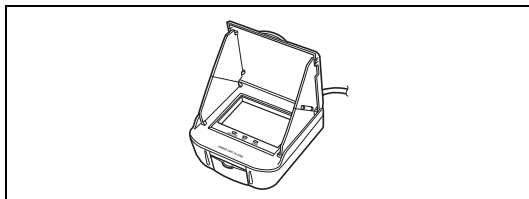

This mark identifies genuine Canon video accessories. When you use Canon video equipment, we recommend Canon-brand accessories or products bearing the same mark.

Specifications

XL H1S / XL H1A

System

Video Recording System	Rotary head, helical scanning, digital component recording (HDV) High Definition Video 1080i (DV) Consumer digital VCR SD system
Audio Recording System	(HDV) MPEG-1 audio layer 2, 16 bit (48 kHz), Transfer rate: 384 kbps (2CH) (DV) PCM digital sound, 16 bit (48 kHz) or 12 bit (32 kHz)
Television System	(HD) High Definition Video (HDV) 1080/50i (SD) CCIR standard (625 lines, 50 fields) PAL color signal
Tape Format	Videocassettes bearing the "MiniDV" mark.
Tape Speed	(HDV) 18.83 mm/s (DV) SP: 18.83 mm/s, LP: 12.57 mm/s
Maximum Recording Time (60 min. cassette)	(HDV) 60 min. (DV) SP: 60 min., LP: 90 min.
Fast Forward/Rewind Time	Approx. 2 min. 20 sec. (with a 60 min. cassette)
Image Sensor	1/3-inch CCD x 3 (horizontal pixel shift), approx. 1,670,000 pixels Effective pixels: HD approx. 1,560,000 SD16:9 approx. 1,560,000 SD4:3 approx. 1,170,000
Viewfinder	2.4 in. wide, 16:9 aspect ratio, TFT color, approx. 215,000 pixels, RGB delta configuration
Microphone	M/S Stereo electret condenser microphone
Lens Mount	XL interchangeable mount system
AF System	TTL autofocus, manual focusing with focus ring (with the HD 20x L IS III lens)
White Balance	Auto white balance, pre-set white balance (indoor, outdoor), custom white balance, or color temperature setting
Minimum Illumination	0.4 lx (with HD 20x L IS Lens, 50i/25F mode, Manual mode, Shutter speed 1/3, F1.6, Gain 18 dB)
Recommended Illumination	More than 100 lx
Subject Illumination Range	0.4 to 100,000 lx (50i/25F)

Memory Card

Recording media	SDHC (SD High Capacity) memory card, SD memory card, MultiMedia Card (MMC)*
Size of Images on the Card	1920 x 1080, 1440 x 1080, 848 x 480, 640 x 480 pixels
File Format	Design rule for Camera File system (DCF), Exif 2.2** compliant, DPOF compliant
Image Compression Method	JPEG compression (Super Fine, Fine, Normal)

* The camcorder's operations have been tested with SD/SDHC memory cards up to 16 GB. Performance cannot be guaranteed for all memory cards.

** The camcorder supports Exif 2.2 (also called "Exif Print"). Exif Print is a standard for enhancing the communication between camcorders and printers. By connecting to an Exif Print-compliant printer, the camcorder's image data at the time of shooting is used and optimized, yielding extremely high quality prints.

Terminals

XLH1S HD/SD SDI Terminal	BNC jack, output only, 0.8 Vp-p/75 ohms, unbalanced SDI 576/50i: ITU-R BT.656, SMPTE 272M, SMPTE RP 188 (LTC) HD SDI: SMPTE 292M, SMPTE 299M, SMPTE RP 188 (LTC)
HDV/DV Terminal	Special 6-pin connector (IEEE1394 compliant) input/output
COMPONENT OUT Terminal	1080i (D3)/576i (D1) compatible
S-video Terminal	4-pin mini-DIN jack 1 Vp-p/75 ohms (Y signal), 0.3 Vp-p/75 ohms (C signal)
Video Terminal	VIDEO IN/OUT - RCA jack (input/output), VIDEO OUT - BNC jack (output only) 1 Vp-p/75 ohms unbalanced
Audio Out Terminals	RCA jacks (L, R) -12 dBV (47 kohm load, output level 1Vrms, full-scale -12 dB)/3 kohms or less
🎧 (headphone) Terminal	∅ 3.5 mm stereo mini-jack, -∞ to -12 dBV (16 ohm load, volume range Min to Max) / 50 ohms or less
Audio In Terminals	FRONT MIC: ∅ 3.5 mm stereo mini jack (unbalanced), ATT: 20 dB sensitivity: -61 dBV (manual volume center, normal sensitivity, full scale -12 dB) / 600 ohms AUDIO IN: RCA jack (unbalanced) sensitivity: -12 dBV (47 kohm load, full scale -12 dB) INPUT CH1/CH2: XLR jack (pin1: shield, pin2: hot, pin3: cold), ATT: 20 dB, 2 sets sensitivity: XLR MIC: -60 dBu (manual volume center, normal sensitivity, full scale -18 dB) / 600 ohms XLR LINE: 4 dBu (manual volume center, normal sensitivity, full scale -18 dB) / 10 kohms
XLH1S GENLOCK Terminal	BNC jack, input only, 1 Vp-p/75 ohms
XLH1S TC-IN Terminal	BNC jack, input only, 0.5 V-18 Vp-p/10 kohms
XLH1S TC-OUT Terminal	BNC jack, output only, 1 Vp-p/75 ohms
🎧 (LANC) Terminal	∅ 2.5 mm stereo mini-jack
EVF 1, 2 Terminals	20 pin connector EVF2 terminal for monochrome viewfinder unit or external monitor (component video)

Power/Others

Power supply (rated)	7.4 V (battery pack)
Power consumption	XLH1S 8.4 W; XLH1A 7.9 W (recording using the color viewfinder, autofocus, HD 20x L IS III lens, HD mode)
Operating temperature	0 – 40 °C
Dimensions (W x H x D)	226 x 220 x 496 mm excluding the gripbelt
Weight	With the viewfinder unit and microphone attached: XLH1S 2,560 g XLH1A 2,500 g

Lens

The lens' angle of view may change when it is mounted on the XL H1S / XL H1A. Refer to the following table.

	Angle of View		Field Size at Closest Focusing Distance	
	Wide Angle	Telephoto	Wide Angle	Telephoto
HD 20x L IS II Lens	51° 36' x 30° 29' (16:9)	2° 46' x 1° 34' (16:9)	[20 mm]	[1 m]
HD 20x L IS III Lens	39° 51' x 30° 29' (4:3)	2° 05' x 1° 34' (4:3)	64.8 x 35.4 mm (16:9) 47.7 x 35.4 mm (4:3)	70.5 x 39.7 mm (16:9) 52.9 x 39.7 mm (4:3)
HD 6x L Lens	75° 01' x 46° 48' (16:9) 59° 52' x 46° 48' (4:3)	14° 35' x 8° 15' (16:9) 10° 58' x 8° 15' (4:3)	[20 mm] 86.4 x 47.5 mm (16:9) 63.8 x 47.5 mm (4:3)	[0.5 m] 149.9 x 84.6 mm (16:9) 112.5 x 84.6 mm (4:3)
20x L IS Lens	51° 36' x 30° 29' (16:9) 39° 51' x 30° 29' (4:3)	2° 46' x 1° 34' (16:9) 2° 05' x 1° 34' (4:3)	[20 mm] 64.8 x 35.4 mm (16:9) 47.7 x 35.4 mm (4:3)	[1 m] 70.5 x 39.7 mm (16:9) 52.9 x 39.7 mm (4:3)
16x Manual Zoom Lens	51° 36' x 30° 29' (16:9) 39° 51' x 30° 29' (4:3)	3° 28' x 1° 57' (16:9) 2° 36' x 1° 57' (4:3)	[50 mm] 81.9 x 44.6 mm (16:9) 60.1 x 44.6 mm (4:3)	[1 m] 55.8 x 31.7 mm (16:9) 42.0 x 31.7 mm (4:3)
16x IS II Zoom Lens	50° 46' x 29° 57' (16:9) 39° 11' x 29° 57' (4:3)	3° 24' x 1° 55' (16:9) 2° 33' x 1° 55' (4:3)	[20 mm] 61.7 x 33.7 mm (16:9) 45.3 x 33.7 mm (4:3)	[1 m] 79.3 x 44.7 mm (16:9) 59.4 x 44.7 mm (4:3)

CA-920 Compact Power Adapter

Power supply	100 – 240 V AC, 50/60 Hz
Rated output	Adapter: 7.2 V DC, 2.0 A, 35 VA (100 V AC) - 47 VA (240 V AC) Charger: 8.4 V DC, 1.5 A, 29 VA (100 V AC) - 40 VA (240 V AC)
Operating temperature	0 – 40 °C
Dimensions	75 x 99 x 51 mm
Weight	215 g excluding the power cable

BP-950G Battery Pack

Battery type	Rechargeable lithium ion battery
Rated voltage	7.4 V DC
Operating temperature	0 – 40 °C
Battery capacity	5,200 mAh
Dimensions	38.2 x 40.3 x 70.5 mm
Weight	210 g

Weight and dimensions are approximate. Errors and omissions excepted. Subject to change without notice.

A	
Abroad, using the camcorder	145
Accessories	8, 150
AE shift	65
AEB - Auto exposure bracketing	120
Analog line-in	89
Analog/digital (A/D) converter	90
Aperture	61, 64
Aspect guides	132
Aspect ratio	38
Audio level indicator	55
Audio mode (SD)	53
Audio output	86
Audio peak limiter	55
Audio recording	53
Audio reference signal	79
Auto (programmed AE mode)	58
Av (programmed AE mode)	64
B	
Battery pack	15, 142
Black level	97
Built-in backup battery	16
C	
Clear scan	74
Color bars	79
Color correction	70
Color gain	98
Color matrix	98
Color phase	98
Compact power adapter	15
COMPONENT OUT terminal	83
Condensation	144
Connection to a computer	91
Connection to a High Definition TV (HDTV)	82
Connection to a TV	81, 84
Continuous shooting	120
Coring	98
Custom displays	136
Custom functions	100, 135
Custom keys	75
Custom presets	92, 134
D	
Data code	113
Date and time	32
Date format	33
Date search	113
DC coupler	16
Drive mode	120
DV control	88
E	
Easy recording (programmed AE mode)	59
Embedded audio*	56
End search	39
Erasing still images	125
Error messages	140
Exposure	65
Exposure lock	65
External synchronization*	50
External video input	89
F	
Faders	79
File numbers	116
Flange back adjustment	26
Flash	122
Focus	42
Focus assist functions	44
Focus limit	46
Focus preset	45
Frame rate	48
Free-run (time code)	49
G	
Gain	66
Gain fine-tuning	66
Gamma	97
Genlock*	50
H	
HD 20x L IS III Lens	25
HD/SD SDI terminal*	82
HD/SD video signal standards	5
HDV/DV tape recording standards	5
HDV/DV terminal	83, 89, 91
I	
Image stabilizer	57
Index search	112
Index write	76
Initializing the memory card	127
K	
Knee	97
L	
Language	33
Lens hood	26
Low-angle recording	35
M	
Macro shooting	46
Magnifying (focus assist)	44
Manual (programmed AE mode)	61
Manual focus	43
Markers	132
Master pedestal	97
Memory card	30, 143
MENU settings	31, 129
Metering mode	121
Microphone	23, 54
Microphone attenuator	54, 55
N	
ND filter	47
Night (programmed AE mode)	58
NR (noise reduction)	98
P	
Peaking (focus assist)	44
Phantom power (microphone)	54
Playback - Movies	110
Playback - Still images	123
POWER dial	9

Power save	35
Print order	128
Programmed AE	58
Protecting still images	126

R

Record review	37
Recording - Movies	34
Recording - Still images	117
Recording mode (SD)	131
Rec-run (time code)	49
Rec-run preset (time code)	49
Remaining battery	36
Remaining tape	36
Remote sensor	28
RESET	146
Reviewing still images (Review)	119

S

Safety zone	132
Screen displays	138
SD/SDHC memory card	30
Selective NR	73
Setup level	97
Sharpness	98
Shutter speed	61, 63
Side panel	139
Signal standard	38
Simultaneous recording	118
Skin detail	72
Slideshow	123
Specifications	153
Spotlight (programmed AE mode)	58

Standby mode	35, 137
Still image quality	115
Still image size	115

T

Tape protection	143
Temporary autofocus (Push AF)	42
Temporary automatic exposure (Push AE)	62
Time code	49
Troubleshooting	146
Tv (programmed AE mode)	63

U

User bit	52
----------------	----

V

VCR Stop	35
Video heads, cleaning	144
Video output standards	80
Videocassettes	29, 143
Viewfinder	19

W

White balance	67
Wireless controller	14, 28, 114

Z

Zebra pattern	69
Zero set memory	112
Zoom	40
Zoom preset	41
Zoom speed	40



DIE-308

Canon

Canon Europa N.V.

Bovenkerkerweg 59-61, 1185 XB Amstelveen, The Netherlands

Canon UK Ltd.

CCI Service Centre, Unit 130

Centennial Park, Borehamwood, Hertfordshire, WD6 3SE, England

Telephone 0870-241-2161

Canon Australia Pty. Ltd.

Info-Line: 131383

www.canon.com.au

Canon New Zealand Ltd.

Customer Care: (09) 489 0470

www.canon.co.nz

Canon Singapore Pte. Ltd

1 HarbourFront Avenue, #04-01 Keppel Bay Tower, Singapore 098632

Tel: (65) 6799 8888

Fax: (65) 6799 8882

Canon Hongkong Company Ltd

19/F, The Metropolis Tower, 10 Metropolis Drive,

Hunghom, Kowloon, Hong Kong

Canon Latin America, Inc.

Sales & Enquiries: 703 Waterford Way, Suite 400, Miami, FL 33126 USA

The information in this manual is verified as of March 2008.