

Panasonic

ideas for life

NTSC/PAL

2007/4

3CCD Convertible Cameras
Pan-tilt Systems
Compact Live switchers



Panasonic camera systems for a wide range of locations



An extensive lineup enabling configuration of the optimum

You can configure peripheral components around a high image quality 3CCD convertible camera to achieve the ideal system for any application.

High resolution, high image quality

Original key devices such as the 12-bit A/D converter enable sophisticated image processing.

Flexible system configuration

The extensive lineup lets you create a system boasting Panasonic's

Broad selection of peripherals

Enables optimum system configuration

3CCD Convertible Camera

Panasonic's camera offers high quality images by advanced

2/3-inch Bayonet Mount

AW-E860



16:9/4:3 Switchable Wide Image Shooting Camera

- 2/3" 3CCD high image quality
- Switchable 16:9/4:3 aspect ratios
- Horizontal resolution: 850 lines
- Signal to noise ratio: 65 dB (NTSC)/ 63 dB (PAL) (DNR on)
- High sensitivity: 2 000 lx, F11
- Minimum illumination: 0.4 lx, (F1.7, Night Eye H)
- Wide dynamic range: 600 %
- Compact size, light weight and low power consumption

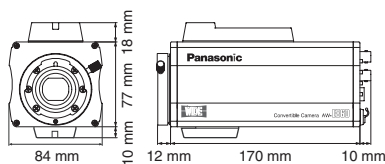

Power supply	DC12 V
Power consumption	Approx.15.4 W
Dimensions (W x H x D)	3-5/16 " x 3-3/4 " x 7-9/16 " (84 mm x 95 mm x 192 mm)
Weight	Approx.2.5 lbs (1.15 kg)

AW-E750



High Sensitivity, Wide Dynamic Range Camera

- 2/3" 3CCD high image quality
- Horizontal resolution: 850 lines
- Signal to noise ratio: 67 dB (NTSC)/ 65 dB (PAL) (DNR on)
- High sensitivity: 2 000 lx, F14
- Minimum illumination: 0.005 lx, 0.00005 lx (2-second CCD charge accumulation)
- Wide dynamic range: 600 %
- Compact size, light weight and low power consumption

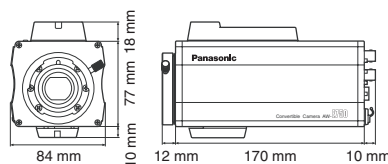

Power supply	DC12 V
Power consumption	Approx.12.6 W
Dimensions (W x H x D)	3-5/16 " x 3-3/4 " x 7-9/16 " (84 mm x 95 mm x 192 mm)
Weight	Approx.2.4 lbs (1.1 kg)

1/2-inch Bayonet Mount

AW-E655



Camera Equipped with Motor-driven Optical Filter

- 1/2" 3CCD high sensitivity
 - Horizontal resolution: 850 lines
 - Signal to noise ratio: 67 dB (NTSC)/ 65 dB (PAL) (DNR on)
 - High sensitivity: 2 000 lx, F14
 - Minimum illumination: 0.005 lx, 0.00005 lx (2-second CCD charge accumulation)
 - Motor-driven optical filter (3 200 K, 1/16ND, 1/64ND, IR through)
- The AW-E655's optical filter rotates to facilitate its use as an infrared camera capable of shooting completely dark scenes from a distance.

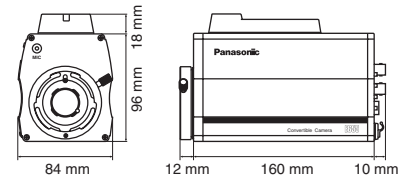

Power supply	DC12 V
Power consumption	Approx.12 W
Dimensions (W x H x D)	3-5/16 " x 4-1/2 " x 7-3/16 " (84 mm x 114 mm x 182 mm)
Weight	Approx.2.6 lbs (1.2 kg)

2/3" Lenses for AW-E860/E750

AW-LZ17MD9A

- 17x MD zoom lens
- Focal length: 9 mm-153 mm (F1.9-2.6)



AW-LZ17ST9A

- 17x studio zoom lens
- Focal length: 9 mm-153 mm (F1.9-2.6)



1/2" Lenses for AW-E655/E650

AW-LZ16MD73

- 16x MD zoom lens
- Focal length: 7.3 mm-117 mm (F1.9-2.3)



system for your needs.

exceptional reliability throughout.

for a wide range of applications including program production.



DSP(Digital Signal Processing) with clean DNR(Digital Noise Reduction) and 12 vector matrix masking.

AW-E650



High Sensitivity, High Image Quality Camera

- 1/2" 3CCD high image quality
- Horizontal resolution: 850 lines
- Signal to noise ratio: 67 dB (NTSC)/ 65 dB (PAL) (DNR on)
- High sensitivity: 2 000 lx, F14
- Minimum illumination: 0.005 lx, 0.00005 lx (2-second CCD charge accumulation)
- Compact size, light weight and low power consumption

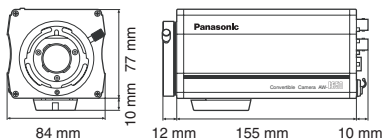

Power supply	DC12 V
Power consumption	Approx.11.8 W
Dimensions (W x H x D)	3-5/16 " x 3-1/32 " x 6-15/16 " (84 mm x 77 mm x177 mm)
Weight	Approx.2.02 lbs (0.92 kg)

1/3-inch C-Mount

AW-E350



Cost Effective C-Mount Lens Camera

- 1/3" 3CCD C-mount lens camera
- Horizontal resolution: 850 lines
- Signal to noise ratio: 66 dB (NTSC)/ 64 dB (PAL) (DNR on)
- High sensitivity: 2 000 lx, F9.5
- Minimum illumination: 0.015 lx, 0.00015 lx (2-second CCD charge accumulation)
- Compact size, light weight and low power consumption

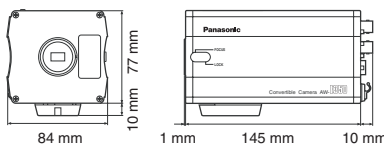

Power supply	DC12 V
Power consumption	Approx.11.3 W
Dimensions (W x H x D)	3-5/16 " x 3-1/32 " x 6-1/8 " (84 mm x 77 mm x 156 mm)
Weight	Approx.1.5 lbs (0.7 kg)

Feature Cards

SDI Card AW-PB504

Digital connecting card for video equipment with SDI input jack

- Output: Serial digital interface (SMPTE259M [4:2:2 SDI])
- Zoom/focus of the MD lens can be controlled by contact closure type pan-tilt head control or a controller without a pan-tilt head.

*Lens control is not servo type control.



Studio Card AW-PB305A

Studio camera system card

- Output: RGB, Y/Pr/Pb, Y/C, VBS
- 4-inch EVF (Zebra, safety zone, and center marker are included), and intercom input and output, and tally output compatible
- EVF interface bracket is included



SDI Studio Card AW-PB506A

Studio and SDI Cards are integrated into one.

- SDI Output: SMPTE259M compatible
- View finder connector is mounted
- Intercom jack and intercom audio volume mounted on the EVF interface bracket
- EVF interface bracket is included



Lens Control kit

AW-LK30

- For MD (Motor Drive) Lenses
- Cable Length: 190 cm



WV-LK36

- For Studio Zoom Lens AW-LZ17ST9A AW-LZ17ST66



WV-LK35

- For Canon Zoom Lens

AW-LK50

- For Studio Zoom Lens AW-LZ16ST55



AW-LZ17ST66

- 17x studio zoom lens
- Focal length: 6.6 mm-114 mm (F1.5-1.9)



1/3" Lenses for AW-E350

AW-LZ16MD55

- 16x MD zoom lens
- Focal length: 5.5 mm-88 mm (F1.4-1.8)



AW-LZ16ST55

- 16x studio zoom lens
- Focal length: 5.5 mm-88 mm (F1.4-1.8)



Pan-tilt Head

Multiple types of pan-tilt heads are available for professional camera applications both indoors and outdoors.

Indoor



High Performance Pan-tilt Head

AW-PH400

A high performance, high speed, quiet pan-tilt head

- Pan range: 400 ° Tilt range: 190 °
- Maximum pan/tilt speed: 90 ° /sec (variable speed)
- Stop accuracy: Maximum 30 seconds (Approx.0.008 degrees)
- Noise: Under NC30 (at 30 ° /sec)
- Maximum load: 17.6 lbs (8 kg)
- 10 tracing memories (Maximum time: 600 seconds)
- RS-232C controllable (Through AW-RP400)
- Tally lights are available
- Maximum control distance: 1 640 ft. (500 m) from AW-RP400 (Maximum 3 280 ft. (1 000 m) using protocol converter AW-IF400)
- Last position can be stored.
- Diagonal motion is possible.
- Optional camera rolling unit (AW-RL400) is available
- Teleprompter output
- Both broadcast and industrial motor driven lenses are acceptable.
- Power Supply (standard accessory) can be installed in pan-tilt head.



With Camera Rolling Unit

Camera Rolling Unit

AW-RL400

- Power is supplied from AW-PH400.
- Convertible cameras are mountable
- Controlled by AW-RP400.

Power supply	DC24 V, Approx.24 W
Maximum load	8.8 lbs (4 kg)
Rotation range	380 ° (±190 °)
Maximum speed	60 ° /s
Weight	Approx.8.8 lbs (3.9 kg)
Dimensions(W x H x D)	8-1/16 " x 7-13/16 " x 10-1/4 " (205 mm x 198 mm x 260 mm)

Indoor Pan-tilt Head

AW-PH405

A compact pan-tilt head for heavy load



- High pan-tilt speed: 45 ° /sec
- Quiet motion: Noise level under NC35 (at 30 ° /sec)
- Accuracy (±3 minutes) (0.05 degrees)
- Maximum load: 33.1 lbs (15 kg) (using with a camera, a lens and a teleprompter)
- Pan range: 300 ° Tilt range: 300 °
- 50 preset positions and 10 tracing memories (Maximum time: 300 sec) are available when using the pan-tilt head controller AW-RP655.*
- Up to five camera systems can be controlled using Panasonic controllers (AW-RP655/RP555/RP400**)
- Maximum control distance: 4 920 ft. (1 500 m)...AW-RP400 + AW-IF400 (optional protocol converter) 3 280 ft. (1 000 m)...AW-RP655/RP555
- A removable tally light is available on the pan-tilt head.
- RS-232C controllable (through Panasonic controllers)
- Professional motor drive lenses and broadcast ENG lenses*** can be connected.

* You can't use tracing memories if you use the AW-RP400 in combination with the AW-IF400.

** Use together with the AW-IF400 if you use the AW-RP400.

*** Use an optional cable if you use a broadcast ENG lens.



Indoor Pan-tilt Head

AW-PH360

A compact pan-tilt head with a wide pan-tilt range

- Pan angle: 300 ° Tilt angle: 190 °
- High performance: Quiet (Under NC30)
- Pan speed (30 ° /sec) / Tilt speed (25 ° /sec)
- Accuracy (±3 minutes) (0.05 degrees)
- Smooth starts and stops with soft landing function
- 50 preset memories
- Maximum load: 8.8 lbs (4 kg)
- Maximum control distance 1 640 ft. (500 m) from AW-RP400* 3 280 ft. (1 000 m) from AW-RP655/RP555
- RS232C interface

* AW-PH360 requires Power Supply AW-PS300A.

Power Supply

AW-PS300A

Power supply	AC120 V 4.9 A (NTSC)/AC220 V to 240 V (PAL)
Dimensions(W x H x D)	8-1/4 " x 2 " x 10-13/16 " (210 mm x 51 mm x 275 mm)
Weight	Approx.4.8 lbs (2.2 kg)

Outdoor



Outdoor Pan-tilt Head

AW-PH650

Waterproof design for stable shooting despite the rain

- Pan angle: 320 ° (±160 °) Tilt angle: +50 ° -90 °
- High performance: Quiet (Under NC40)
- Pan speed (20 ° /sec) Tilt speed (20 ° /sec)
- In addition to zooming, panning and tilting functions, heater, wiper and defroster functions for the housing can also be controlled by the controller.
- 50 preset memories
- Maximum load: 22 lbs (10 kg)
- Maximum control distance: 3 280 ft. (1 000 m)
- Camera housing, power supply and cables are included with the AW-PH650.
- Accessories: power cable (approx. 98 ft. (30 m), control cable (approx. 32.8 ft. (10 m), camera cable (approx. 1 .312 ft. (0.4m) for C-CAM/AK-HC910/HC1500)

Housing	
Dimensions(W x H x D)	26-15/16 " x 10-7/16 " x 9-5/8 " (685 mm x 265 mm x 245 mm)
Weight	Approx.41.9 lbs (19 kg)
Power Supply	
Dimensions(W x H x D)	7-7/8 " x 4-3/4 " x 11-1/16 " (200 mm x 121 mm x 280 mm)
Weight	Approx.9 lbs (4.5 kg)

Control Panel

Pan-tilt systems for multiple cameras ready for a wide range of applications.

Multi-function Controller

Multi-function Controller **AW-RP655**



(Rear view)

High performance multi-function controller with full camera control function

- Controls maximum five cameras and five pan-tilt heads without hub unit.
- Full camera control by LCD menu
- Control speed can be adjusted by the angle of the operation lever and high speed and low speed mode can be switched.
- 50 pre-set memories per camera
- Ergonomically designed joystick controller
- Maximum 300 seconds tracing memory
- Maximum control distance from controller to pan-tilt head: 3 280 ft. (1 000 m) (AW-PH360,AW-PH650) This controller can control an AW-PH400 by using a protocol converter (AW-IF400).
- The motion direction of the operation lever can be reversed.
- Two additional controllers can be connected.
- This controller can be placed on a desk or mounted in a rack.
- Power Supply AW-PS505A is required.

Power supply	DC12 V (DC10.8 V to 16 V)
Power consumption	Approx.9.0 W
Dimensions(W x H x D)	16-1/2 " x 2-1/16 " x 8-11/16 " (420 mm x 52 mm x 220 mm)
Weight	Approx.7.7 lbs (3.5 kg)
Accessories	Rack mounting adapters (5U) x 2 Mounting screws (M4 x 8 mm) x 4

Compact Size Controller

Compact size controller **AW-RP555**



(Rear view)

Compact controller with full camera control function

- Controls up to five cameras and five pan-tilt heads.
- Full camera control by camera menu
- Speed of controls can be adjusted by the angle of the operation lever.
- 10 pre-set memories per camera
- Maximum control distance from pan-tilt head to controller: 3 280 ft. (1 000 m) (AW-PH360,AW-PH650)
- With a protocol converter (AW-IF400), this controller can control the AW-PH400.
- The motion direction of the operation lever can be reversed or changed.
- This controller can be placed on a desk or mounted in a rack. (The position of input and output connectors can be changed by 90 degrees)
- Power Supply AW-PS505A is required.

Power supply	DC12 V (DC10.8 V to DC16 V)
Power consumption	Approx.9.0 W
Dimensions(W x H x D)	8-1/4 " x 2-5/16 " x 8-15/16 " (210 mm x 58 mm x 177 mm)
Weight	3.08 lbs (1.4 kg)
Accessories	Rack mounting adapters (5U) x 2 Mounting screws (M4 x 8 mm) x 4

Pan-tilt Controller

Pan-tilt Controller **AW-RP400**

Joystick controller can be changed for seesaw controller. (Standard accessory)



Seesaw controller



(Rear view)

High performance controller for professional and broadcast use

- Changeable zoom/focus controller (joystick/seesaw)
- Joystick with camera roll control
- 50 preset positions
- 5 pan-tilt heads control
- Zoom/Focus/Pan/Tilt speed control
- Tally/Intercom function
- 10 minutes tracing memory (60 seconds x 10 positions)*
- RS232C interface
- Maximum control distance:1 640 ft. (500 m)**
- Cross control by two controllers
- Camera control inputs (AW-CB400)
- +DC12 V operation (Power Supply AW-PS505A is required.)

* This function does not work for AW-PH405/PH650.

** Maximum 3 280 ft. (1 000 m) by using the Protocol Converter AW-IF400.

Power supply	DC12 V
Power consumption	Approx.13 W
Weight	Approx.8.4 lbs (3.8 kg)
Dimensions(W x H x D)	8-1/4 " x 3-7/16 " x 6-15/16 " (210 mm x 88 mm x 177 mm)
Accessories	Rack mounting plate x 2 Mounting screws (M4 x 8 mm) x 4 Seesaw controller

Camera Controller/Switcher

Remote Operation Panel

Remote Operation Panel AW-CB400



Remote control panel enabling full control of up to 5 cameras

- Controls five cameras
- Full camera control
- +DC12 V operation*
- Tally/Intercom function**

* Power is supplied from AW-RP400.
Power supply AW-PS505A is required for controlling cameras directly
(Maximum control distance: 3 280 ft. (1 000m).
** Intercom function is not available if the AW-CB400 is connected directly to the camera.

Power supply	DC12 V, Approx.3.8 W
Weight	Approx.3.08 lbs (1.4 kg)
Dimensions(W x H x D)	3-5/16 " x 3-3/8 " x 10-7/16 " (100 mm x 85 mm x 266 mm)
Accessories	Pan-tilt controller connection cable (32.8 ft. (10 m))

Remote Control Unit (RCU)

Remote Control Unit AW-RC600

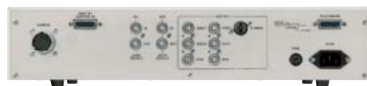

Basic camera controls on the front panel and full camera control by camera menu

- Composite, Y/C and component (Y/Pb/Pr, R/G/B) outputs
- By using RCU cable (AW-CA50A26) and extension cables (WV-CA26T26, WV-CA26U/15/30/100), this unit can control a camera at a maximum distance of approx. 328 ft. (100 m) (with viewfinder AW-VF64)
- Camera power can be supplied by this RCU.
- Equipped with tally/intercom, AUX (for line view) inputs, and contact-closure type pan-tilt head control input terminal (15-pin D-sub)

Power supply	AC120 V (NTSC)/AC220 V to 240 V (PAL)
Power consumption	Approx.67 W
Dimensions(W x H x D)	16-1/2 " x 3-7/16 " x 9-13/16 " (420 mm x 88 mm x 250 mm)
Weight	Approx.13.2 lbs (5.6 kg)
Accessory	4P connector for tally/intercom, Display panel, Mounting bracket, Rack mount screw x 4

Cable Compensation Unit

Cable Compensation Unit AW-RC400



- Five channels compensation
- Composite, Y/C, Y/Pb/Pr, R/G/B (Composite, Y/C, Y/Pb/Pr, R/G/B video signals can be compensated by maximum 1 640 ft. (500 m))
- +DC12 V operation (Power Supply AW-PS505A is required.)

Power supply	DC12 V, Approx.9 W
Weight	Approx.8.14 lbs (3.7 kg)
Dimensions(W x H x D)	16-1/2 " x 3-7/16 " x 9-13/16 " (420 mm x 88 mm x 250 mm)
Accessories	Screw (M4 x 8 mm) x 3

Compact Live Switcher

Compact Live Switcher AW-SW350



High quality 5-input live switcher for multi use

- 5 inputs (composite and YC) in compact body (half rack size)
- Three program outputs and one preview output
- Selectable bus switching system
- 10 bit, 5-channel frame synchronizer/genlock system are switchable
- Frame capture, soft wipe and linear key
- +DC12 V operation
- Tally and intercom function
- Power Supply AW-PS505A is required.

Power supply	DC12 V
Power consumption	Approx.1.35 A (16 W)
Dimensions(W x H x D)	8-1/4 " x 3-3/8 " x 6-15/16 " (210 mm x 86 mm x 176 mm)
Weight	Approx.4.8 lbs (2.2 kg)
Accessories	Tally/Intercom connector x 5, Rack mounting clamp x 2, Connection bracket, Screw kit, Image transfer setup CD

Cable/Other Peripheral

Cables

Name	Number	Connection apparatus		Length	Note
Cable joint adapter	WV-CA26T26	AW-E750 etc.	WV-CA26U15 etc.		Connects AW-CA50A26 to longer lengths
Studio cable (26P-26P)	WV-CA26U15 / 30 / 100	AW-E750 etc.	AW-RC600	15 m, 30 m, 100 m	
Lens extension cable	AW-CA12T12A	AW-E750 etc.		0.15 m	12P-12P
RCU cable	AW-CA50A26	AW-E750 etc.	AW-RC600	15 m	
RGB cable	AW-CA50T6	AW-E750 etc.	Moniator, VTR etc.	5 m	BNCx5 + S terminal
RS-232C pan-tilt cable	AW-CA28T9	AW-PH360	PC.	5 m	A pan-tilt head is controlled by a PC.
RS-232C camera control cable	AW-CA50T9	AW-E750 etc.	PC.	10 m	A camera is controlled by a PC.
Camera control cable	AW-CA50T8	AW-E750 etc.	AW-CB400	10 m	
Pan-tilt cable kit	AW-CAK4H1	AK-HC1500	AW-PH400/PH405	0.7 m/3 m	Pan-tilt cable: 0.7 m, Control cable: 3 m
Pan-tilt cable	AW-CA15H29	AK-HC1500	AW-PH400/PH405	0.7 m	
Lens cable for Fujinon ENG lens	AW-CA4FLZ	Fujinon ENG (RD) lens	AW-PH400/PH405	0.8 m	for AK-HC1500/AW-E860
Lens cable for Canon digital lens	AW-CA4DLZ	Canon ENG digital lens	AW-PH400/PH405	0.8 m	for AK-HC1500/AW-E860
Lens cable for Canon analog lens	AW-CA4ALZ	Canon ENG analog lens	AW-PH400/PH405	0.8 m	for AK-HC1500/AW-E860
Pan-tilt control extension cable	AW-CA24T24	AW-PH650	AW-RP655/RP555/RP400	20 m	

Other Peripherals

Protocol Converter

Protocol Converter AW-IF400



- High performance pan-tilt head (AW-PH400) can be controlled by controllers (AW-RP555, AW-RP655) by using this protocol converter (AW-IF400). (Max.control distance: 4 920 ft. (1 500 m))
- Outdoor pan-tilt head (AW-PH650) can be controlled by a high performance controller (AW-RP400) by using this protocol converter (AW-IF400). (Max.control distance: 4 920 ft. (1 500 m))
- By using protocol converter AW-IF400, control distance between AW-PH400 & AW-RP400 can be extended up to 3 280 ft. (1 000 m).
- Power Supply AW-PS505A is required.

Power supply	DC12 V (DC10.8 V to DC16 V)
Power consumption	Approx.1.5 W
Dimensions(W x H x D)	5-11/16 " x 1-3/16 " x 3-3/8 " (145 mm x 30 mm x 85 mm)
Weight	Approx.0.88 lbs (0.4 kg)

Public Telephone Line Connecting Adapter/ RS232C Distribution Adapter

AW-DU600

Enables remote control of camera and pan-tilt head



- Power Supply AW-PS505A is required.
- Using a public telephone line enables remote control of camera and pan-tilt head through the AW-RP555/ RP655 series models and a PC.
- Up to 5 sets of camera and pan-tilt heads can be controlled with the distribution function.
- Directly controllable pan-tilt and zoom/focus.

* The product is not available in some areas.
** A modem is required.

Power Supply AW-PS505A

The unit can supply power to Convertible cameras, Live switchers, the AW-RP655, AW-RP555, AW-DU600 and other units.



Power supply	AC120 V (NTSC)/AC220 V to 240 V (PAL)
Power consumption	Approx.76 W
Dimensions (W x H x D)	5-3/16 " x 2 " x 10-13/16 " (132 mm x 51 mm x 275 mm)
Weight	Approx.3.5 lbs (1.6 kg)
Accessories	DC cable with 4-pin Canon connector (for AW-RP400.etc.): Approx.6.5 ft. (2 m) DC cable with ø5.5 plug (for AW-RC400.etc.): Approx.9.8 ft. (3 m) DC cable with ø6.5 plug (for convertible cameras): Approx.9.8 ft. (3 m)

4" B/W Viewfinder AW-VF64



* Aspect ratio: 4:3 only

Power supply	DC12 V (supplied from camera head)
Power consumption	Approx.9 W
Dimensions (W x H x D)	5-1/16 " x 6-1/4 " x 12-15/16 " (128 mm x 158 mm x 330 mm)
Weight	Approx.3.5 lbs (1.6 kg)
Accessories	Mounting base x 1, Mounting screw x 2

Indoor Event Shooting

Quiet, accurate and high speed pan-tilt motion for event shooting

Key points

- Compact size camera and pan-tilt head
- Quiet, accurate and high speed pan-tilt head
- Pre-set memory function
- Multi-function control
- Maximum control distance: 3 280 ft. (1 000 m)

Parliament/Hall

Many cameras and quiet pan/tilt-heads can be controlled from several control rooms.



Convertible cameras (AW-E750/E655/E650) can shoot in dark settings such as parliament, halls or theaters thanks to high sensitivity (Minimum illumination: 0.005 lx). A total of 250 pre-set memories (50 presets per camera) can memorize 250 seats in a conference hall when 5 cameras are used.

System example

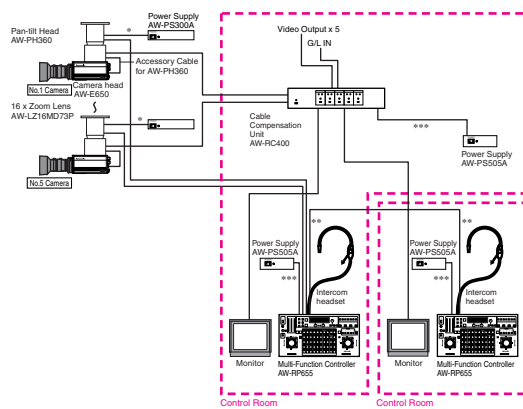

* Local procurement
 ** 10 BASE-T Straight cable x 1
 *** Accessory Cable for AW-PS505A (2 m)

- Camera Head AW-E650.....5
- 16 x Zoom Lens AW-LZ16MD73.....5
- Pan-tilt Head AW-PH360.....5
- Power Supply AW-PS300A.....5
- Multi-function Controller AW-RP655.....2
- Power Supply AW-PS505A.....3
- Cable Compensation Unit AW-RC400.....1

Address/Sports Relay

Compact size camera and pan-tilt head can be controlled in small event shooting spaces.



Quiet indoor pan-tilt system with no disturbing noise. The pan-tilt head and camera are compact, as well as extremely quiet. The videographer does not need to move around the hall, and is able to shoot without disturbing the scene. Ideal for wedding or religious ceremonies where the atmosphere and mood are very important.

System example

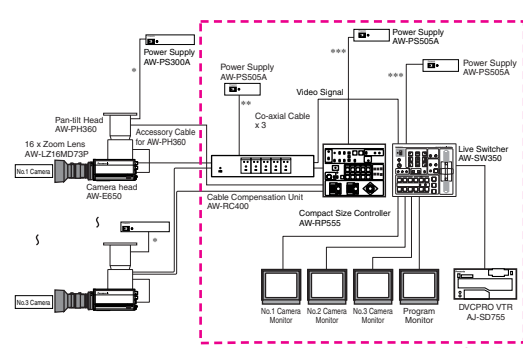

* Local procurement
 ** Accessory Cable for AW-PS505A (3 m)
 *** Accessory Cable for AW-PS505A (2 m)

- Camera Head AW-E650.....3
- 16 x Zoom Lens AW-LZ16MD73.....3
- Pan-tilt Head AW-PH360.....3
- Power Supply AW-PS300A.....3
- Multi-function Controller AW-RP655.....1
- Power Supply AW-PS505A.....3
- Cable Compensation Unit AW-RC400.....1
- Compact Live Switcher AW-SW350.....1
- DVCPRO VTR AJ-SD755.....1

Remote Studios

Content production at small, cost effective studios

Key points

- Many cameras can be used in a small studio.
- SDI video system by SDI card (AW-PB504)
- One operator can control many cameras and pan-tilt heads.
- Quiet pan-tilt motion for shooting in a quiet studio

Remote Studio

A single camera operator can control three cameras in a quiet studio.



One control panel controls three cameras and pan-tilt heads in the studio. By using compact pan-tilt heads, many cameras can be controlled in a small studio. Using the compact live switcher AW-SW350 also enables an operator to produce independently creative images with wipe and other special effects.

System example

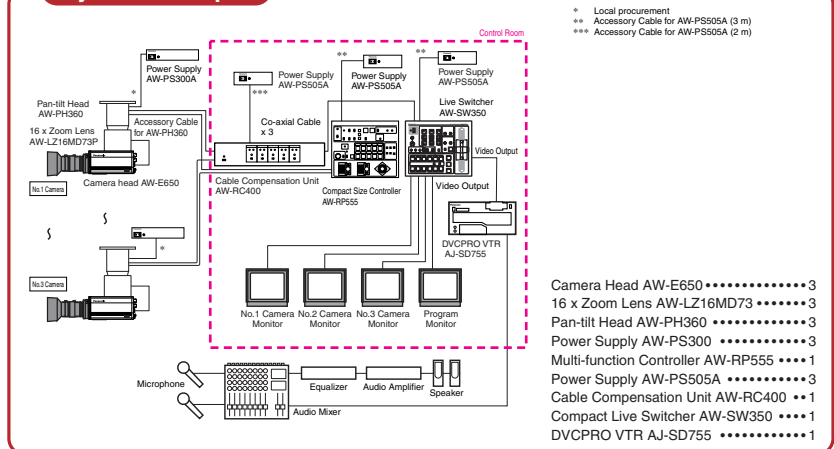

CATV Studio

High quality image SDI recording system for minimizing deterioration of video images.



It can be incorporated in a high quality picture SDI system that records video with little degradation. Inserting SDI output, along with connection to digital equipment, allows video recording without loss of image quality, which is ideal for CATV solutions and professional studios that place importance on picture quality.

System example

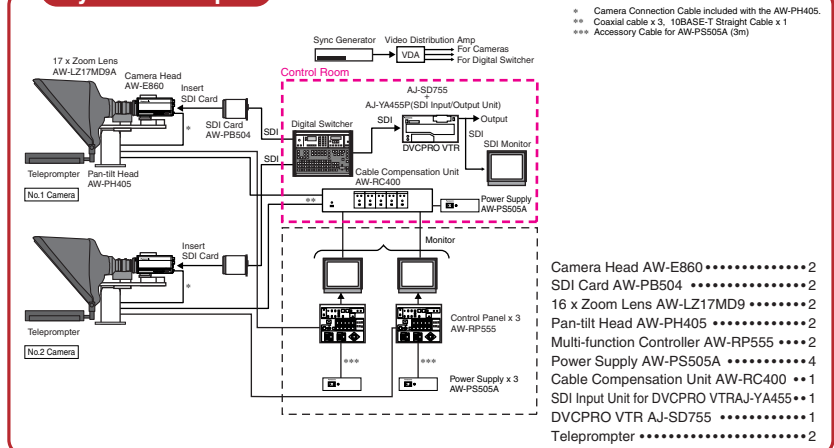

Production systems

Studio systems can be configured using optional studio cards.

Key points

- 3CCD (2/3", 1/2" or 1/3") high quality camera Resolution: 850lines, S/N 67 dB (NTSC)/ 65 dB (PAL)(DNR)
- Two types of studio card: Analog (Composite, Component) output card/ SDI output card
- Intercom, viewfinder, lens control kit and RCU (remote control kit) can be used for studio system.

Production Studio

A convertible camera can be used as a production studio camera by inserting an SDI studio card.



The 2/3" high quality camera AW-E860 or AW-E750 with the SDI studio card AW-PB506A (with two SDI outputs) can be used as high quality studio cameras in production houses or community stations.

System example

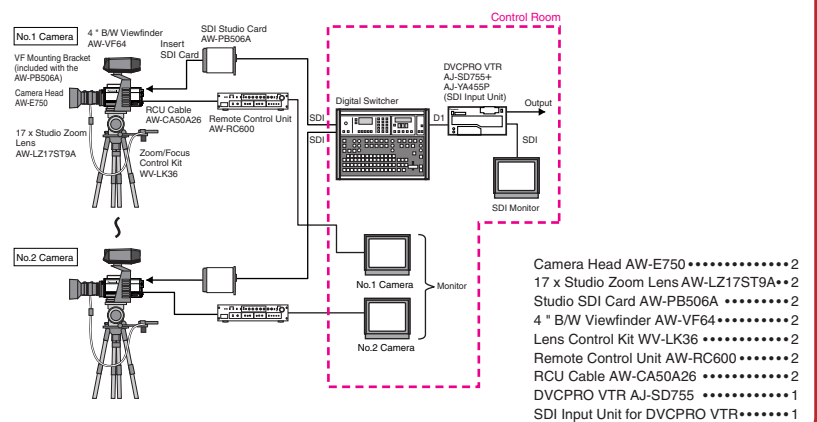

College Studio

A simple, cost effective studio system can be configured by inserting a Studio card.



A compact, easy to operate, low-cost system can be set up by inserting a Studio card into the camera, which is ideal for small size studios in schools, companies, etc.

System example

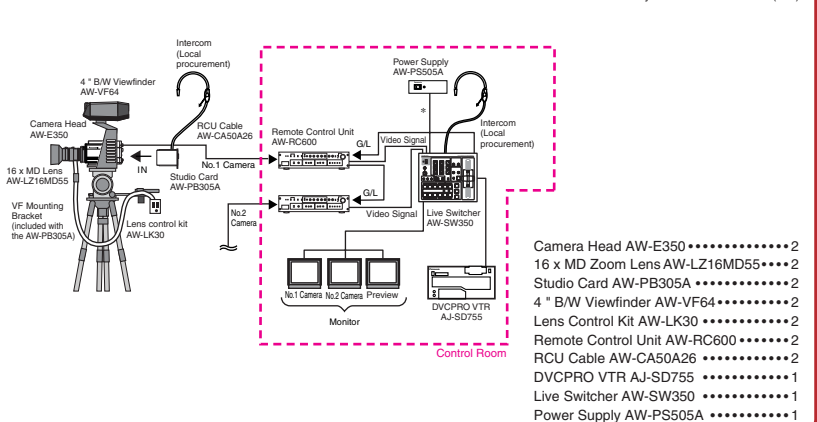

Multi-purpose systems

High quality images indoors and out make them ideal for everything from live sports coverage to use as ceiling cameras.

High speed pan-tilt system

High speed and accurate camera operation can be achieved.



By using the high speed (90degree/ s) pan-tilt head AW-PH400 and high quality controller AW-RP400, high-level camera operation for sports relays or music video production can be achieved.

System example

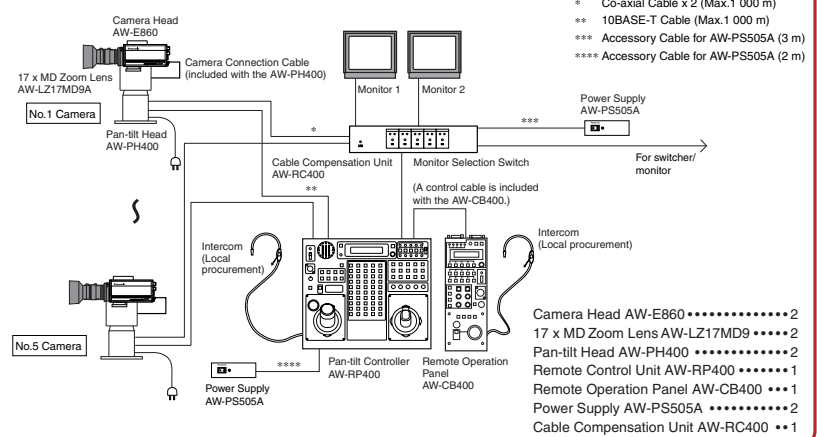

Weather/traffic information camera

High quality images can be supplied in any weather conditions.



Weather/traffic camera system with a waterproof, outdoor pan-tilt head. The camera can be operated by remote control via a PC connection to enable projection of faraway situations on the monitor.

System example

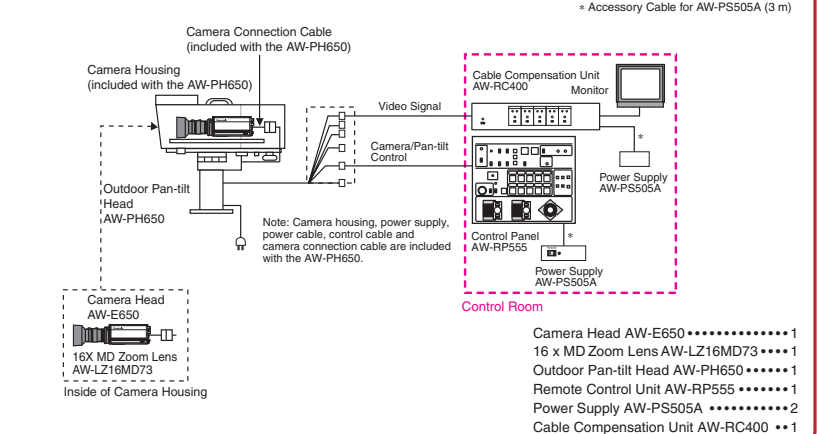

Product configuration diagram

Shooting section

Lens Controller

Lens

Viewfinder

Camera/ Card

Pan-Tilt Head

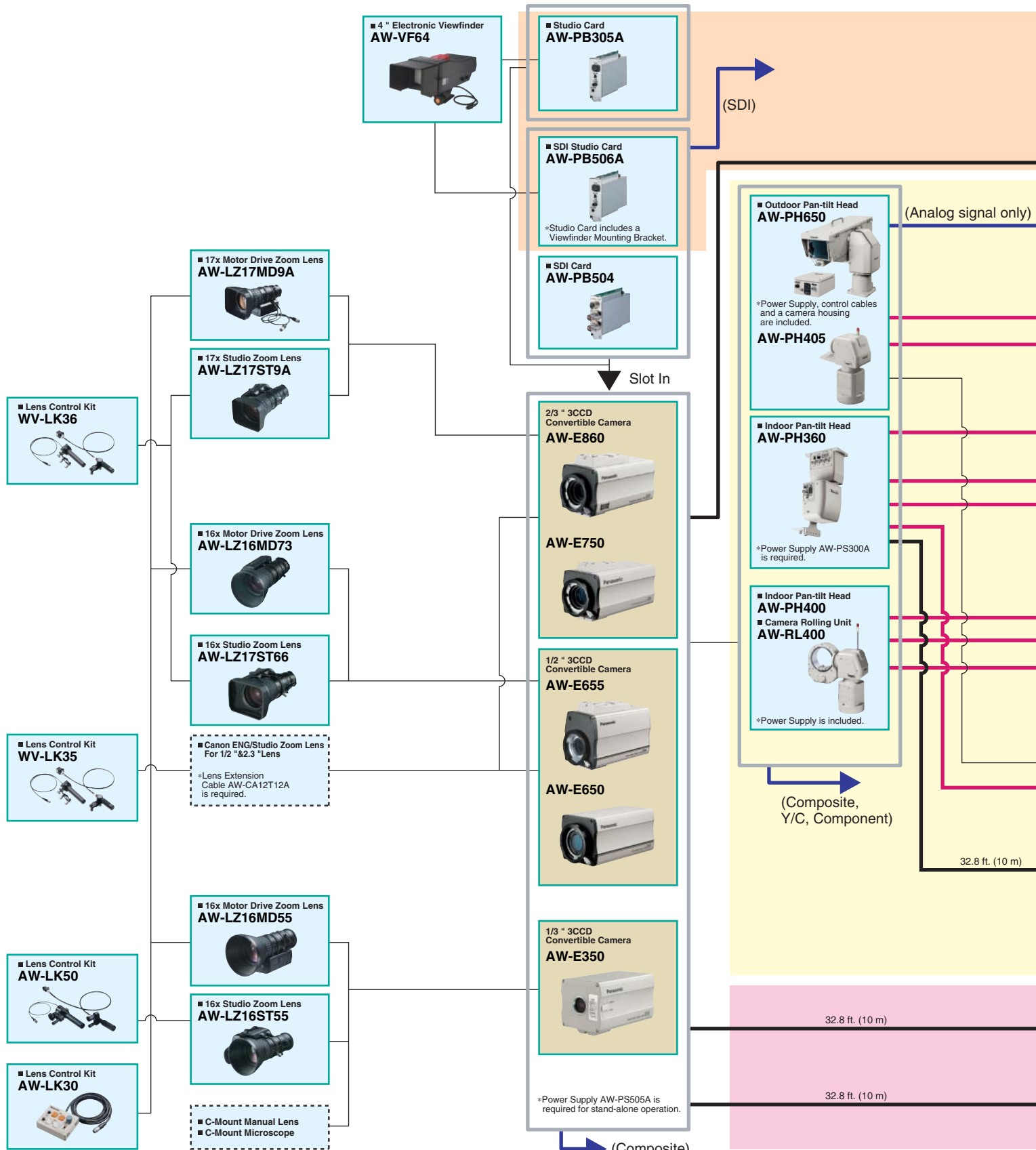

HD camera system

Panasonic also makes it easy to switch from conventional

As the demand for HD production systems continues to grow, Panasonic is there to support you. Models in the lineup offer the flexibility for use with conventional SD systems, while making you more familiar with the HD production environment.



2/3-inch Bayonet Mount

Multi-purpose HD Box Camera **AK-HC1500**



Global multi-format HD/SD compatibility in a compact unit designed for a wide range of applications.

The camera is compatible with multiple formats at home and overseas. What's more, original Panasonic devices such as the 14-bit A/D converter, newly developed DSP and 2/3-inch IT-3CCD assure exceptional image quality and reliability. As well as being ideal for a wide range of applications, this high cost performance HD camera helps assure an easy transition from an SD system to an HD system.

* This camera can be mounted with Fujinon HD 2/3" bayonet mount lenses or Canon HD 2/3" bayonet mount lenses.

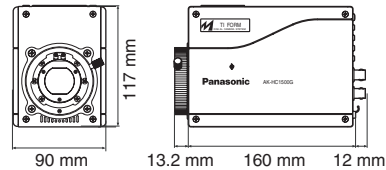

For more details please consult a separate brochure.

Multi-format HD/SD Live Switcher **AV-HS300**



A compact, multi-purpose unit compatible with global HD and SD formats.

Multi-format HD/SD compatibility lets you meet changing needs as production switches to HD worldwide. It also helps assure a trouble-free transition from conventional SD operation to HD operation. Better still, the main unit and control panel are integrated in a compact body while DC 12 V external power operation assures easy maneuverability when producing in the field.

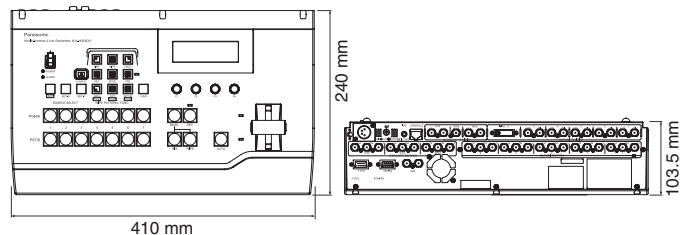

For more details please consult a separate brochure.

SD systems to an HD production environment.

News remote studio camera



Sports relays



System example

HD camera ideal for live sports coverage and other broadcast applications.

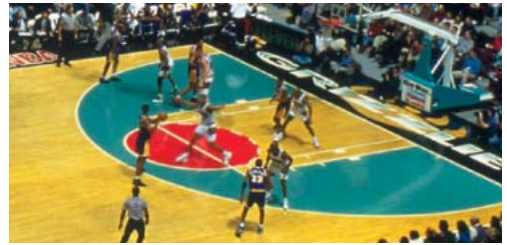

Combining the AK-HC1500 HD Multi-Format Camera with the high-speed, exceptionally quiet AW-PH400 Pan-Tilt System lets you shoot and record high-definition, broadcast-quality images. And with the AV-HS300 Live Switcher, you can use transitions and versatile titling effects for results with incredible presence.

System example

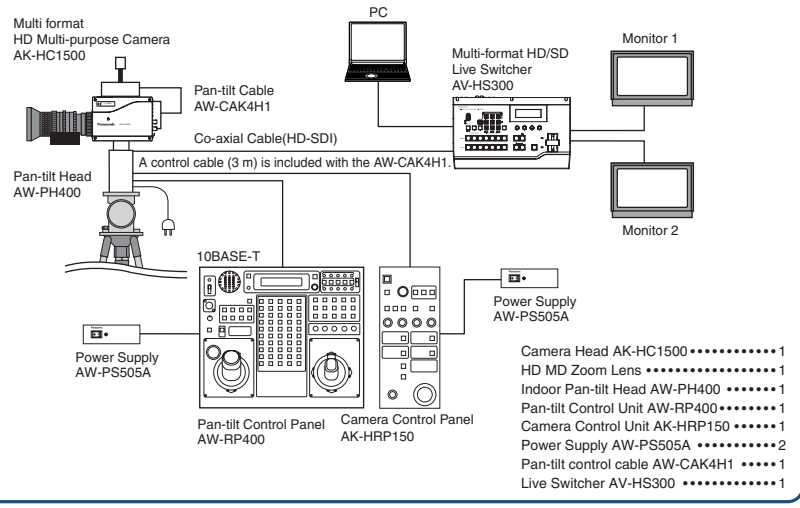

AK-HC1500 specifications

CCD	2/3" 1.0-megapixel IT-3CCD
Image sensing method	GBR Image sensing method
Total number of pixels	1 370(H)x744(V)
Effective number of pixels	1 280(H)x720(V)
Optical prism	F1.4 Prism
Optical filter	(ND) 100 %, 25 %, 6.3 %, 1.6 %
Lens mount	2/3" Bayonet type
Output format	1080: 60i/59.94i/50i/30psF/29.97psF/25psF/24psF/23.98psF 720: 60p/59.94p/50p
Sensitivity	F10.0 at 2 000 lx
Minimum Illumination	0.015 lx (F1.4 / 68 dB)
Gain	72 dB
S/N	54 dB
Smear	Less than -130 dB
M.T.F.	45 % (27.5 MHz, 720 p / 60 p)
Synchronize System	Internal and external synchronization (Tri-level SYNC/Black Burst)
Input	GENLOCK: BNC x 1, Interface: Mini D-sub 15pin terminal
Output	HD-SDI: BNC x 1
Input/output	Lens aperture connector, lens zoom focus connector
Storage temperature	-4 °F to 140 °F (-20 °C to +60 °C)
Operating temperature	32 °F to 104 °F (0 °C to +40 °C)
Power consumption	Approx. 17 W (DC12 V)
Dimensions(WxHxD)	Approx. 3-9/16" x 4-10/16" x 6-5/16" (90 mm x 117 mm x 160 mm)
Weight	Approx. 3.3 lbs (1.5 kg)

AV-HS300 specifications

Video processing	Video format	SD (480: 59.94i, 576: 50i), HD (1080: 59.94i/50i, 720: 59.94p/50p)
	Video processing	Y;Cb;Cr, 4:2:2 10bit RGB, 4:4:4 8bit
Input	SDI	5 inputs (with active through output)
	RGB	DVI-I x 1 (SXGA 1280x1024, XGA 1024/768 (60 Hz))
	HD analog component	5 inputs (Y,Pb,Pr: HD only) *Option
	Key	Possible to assign to a desired input among 5 SDI inputs
	Reference	Black burst/TRI (Loop through) x 1
Output	SDI	3 outputs (PGM x 2, PVW x 1, AUX x 2)
	HD analog component	3 inputs (Y,Pb,Pr: HD only)
	Reference	Loop through x 1 (Gen-lock)/Black burst x 2 (internal synchronization)
Effect	Transition	Cut, Mix, Wipe (9 patterns, 3 directions)
	Key synthesis	Self key, Linear key
Interface	Ethernet	100 Mbps/10 Mbps x 1
	Serial (EDITOR)	Dsub 9pin x 1: RS422A
	Tally output	Dsub 9pin x 1: 6 ch, open collector output
	GPI	1 (auto take)
Operating temperature		32 °F to 104 °F (0 °C to +40 °C)
Humidity		10 % to 90 % (non condensing)
Power		DC 12 V/5 A 46.8 W
Dimensions(WxHxD)		16-1/8" x 4-1/8" x 9-1/2" (410 mm x 103.5 mm x 240 mm) *Excluding protrusions
Weight		Approx. 7.1 lbs (3.2 kg)

* Features and specifications are subject to change without notice due to continual improvements.

■ Camera specifications (NTSC<PAL>)

	AW-E860	AW-E750	AW-E655	AW-E650	AW-E350
Image elements	2/3" IT-3CCD		1/2" IT-3CCD		1/3" IT-3CCD
Pixels	Total elements	Approx.510 000 <595 728>			
	Effective elements	Approx.410 000 <470 000>			
Imaging area (H x V)	9.6 mm x 5.4 mm (2/3" 16:9) (16:9/4:3 switchable)	8.8 mm x 6.6 mm (equivalent to 2/3")	6.4 mm x 4.8 mm (equivalent to 1/2")		4.8 mm x 3.6 mm (equivalent to 1/3")
Scanning system	2:1 interlaced NTSC system <2:1 interlaced PAL system>				
Scanning frequency	Horizontal=15.734 kHz, Vertical=59.94 Hz <Horizontal=15.625 kHz, Vertical=50 Hz>				
Lens mount	2/3" Bayonet Mount		1/2" Bayonet Mount		1/3" C Mount *
Optical filter	None		1/16ND, 1/64ND, 3 200 K, IR Through		None
Synchronize system	Internal/external synchronization				
Standard illumination	2 000 lx, F11		2 000 lx, F14		2 000 lx, F9.5
Minimum illumination	0.4 lx (F1.7, Night Eye H)	0.005 lx (F1.4) 0.00005 lx (F1.4) (2-sec. CCD accumulation)			0.015 lx (F1.4) 0.00015 lx (F1.4) **
Signal-to-noise ratio	65 dB (DNR on) <63 dB (DNR on)>		67 dB (DNR on) <65 dB (DNR on)>		66 dB (DNR on) <64 dB (DNR on)>
Horizontal resolution	850 lines				
Registration	0.05 %				
Image enhancer	Horizontal/vertical				
White balance	A/B 2 memory AWC, ATW				
Black balance	Self-adjusting				
Color bar	SMPTE color bar (setup 0/7.5IRE) <EBU color bar>				
Shutter speed	OFF, 1/100 <1/120>, 1/250, 1/500, 1/1 000, 1/2 000, 1/4 000, 1/10 000 Synchro-scan ELC				
Gain	Manual: max. 42 dB (0 to 30 dB in steps, Night Eye H/L) Auto: max. 42 dB (AGC 0 to 30 dB, Night Eye/H)	Manual: max. 72 dB (0 to 30 dB in steps, Night Eye/H, Digital Gain 0 to 30 dB in 6 dB steps) Auto: max. 42 dB (AGC 0 to 30 dB, Night Eye/H)			
Iris	Auto (Manual by RCU control)				
Video output	Composite: 1 V p-p/75 Ω (BNC, 50P connector) YC: Y 1 V p-p, C 0.286V p-p <0.3 Vp-p> (50P connector) Component: Y 1.0 V p-p, Pr/Pb 0.7 Vp-p, RGB 0.7 Vp-p/75 Ω (50P connector)				
Power	DC 12 V				
Power consumption	Approx. 15.4 W	Approx. 12.6 W	Approx. 12 W	Approx. 11.8 W	Approx. 11.3 W
Operating temperature	14 °F to 113 °F (-10 °C to +45 °C)				
Weight	Approx. 2.5 lbs (1.15 kg)	Approx. 2.4 lbs (1.1 kg)	Approx. 2.6 lbs (1.2 kg)	Approx. 2.02 lbs (0.92 kg)	Approx. 1.5 lbs (0.7 kg)
Dimensions (W x H x D)	3-5/16" x 3-3/4" x 7-9/16" (84 mm x 95 mm x 192 mm)	3-5/16" x 3-3/4" x 7-9/16" (84 mm x 95 mm x 192 mm)	3-5/16" x 4-1/2" x 7-3/16" (84 mm x 114 mm x 182 mm)	3-5/16" x 3-1/32" x 6-15/16" (84 mm x 77 mm x 177 mm)	3-5/16" x 3-1/32" x 6-1/8" (84 mm x 77 mm x 156 mm)

* The lens should be within 4.3 mm from the lens mount face. Otherwise, there is a risk of damaging the camera unit.

** 2-sec. CCD charge accumulation.

■ Pan-tilt head specifications

	Indoor pan-tilt head			Outdoor pan-tilt head
	AW-PH400	AW-PH405	AW-PH360	AW-PH650
Pan-tilt range/speed	Pan: 400 °(90 °/s), Tilt: 190 °(90 °/s)	Pan: 300 °(45 °/s), Tilt: 300 °(45 °/s)	Pan: 300 °(30 °/s), Tilt: 190 °(25 °/s)	Pan: 320 °(20 °/s), Tilt: 145 °(20 °/s)
Repeatability	±30 seconds (0.008 degrees)	±3 minutes (0.05 degrees)	±3 minutes (0.05 degrees)	—
Noise level	Under NC30 (at 30 °/s)	Under NC35 (at 30 °/s)	Under NC30	—
Maximum load	17.6 lbs (8 kg)	33.1 lbs (15 kg)	8.8 lbs (4 kg)	22.2 lbs (10 kg)
Maximum control distance	1.5 km(AW-RP655/RP555 with AW-IF400), 1 km(AW-RP400 with AW-IF400), 500 m(AW-RP400)	1.5 km(AW-RP400 with AW-IF400), 1 km(AW-RP655/RP555)	1 km(AW-RP655/RP555), 500 m(AW-RP400), 1 km(AW-RP400 with AW-IF400)	1.5 km(AW-RP400 with AW-IF400), 1 km(AW-RP655/RP555)
Power	AC120 V(NTSC), AC220 V to 240 V(PAL)	AC120 V(NTSC), AC220 V to 240 V(PAL)	DC12 V	AC120 V(NTSC), AC220 V to 240 V(PAL): Power Supply
Power consumption	Approx. 145 W	Approx. 120 W	0.7 A(pan-tilt head only)	Approx. 120 W
Operating temperature	32 °F to 113 °F(0 °C to 45 °C)	23 °F to 113 °F(-5 °C to 45 °C)	14 °F to 113 °F(-10 °C to 45 °C)	-4 °F to 113 °F(-20 °C to 45 °C)
Dimensions(W x H x D)	12-3/8" x 21" x 7-3/8" (315 mm x 534 mm x 188 mm)	12-9/16" x 16-3/8" x 6-5/8" (319 mm x 416 mm x 168 mm)	5-1/8" x 9-5/8" x 7-9/16" (130 mm x 244 mm x 192 mm)	Head: 9-5/16" x 20-1/8" x 8-3/8" (237 mm x 511 mm x 213 mm)
Weight	22.4 lbs (10.2 kg)	22.4 lbs (10.2 kg)	7.7 lbs (3.5 kg)	Head: 41.9 lbs (19 kg)

* Features and specifications are subject to change without notice due to continual improvements.

* Weight and dimensions shown are approximate.

Panasonic

Panasonic Broadcast & Television Systems Co.

Unit of Panasonic Corporation of North America

www.panasonic.com/broadcast

Government Sales: phone: 201-348-7587

Headquarters: 3 Panasonic Way, 4E-7, Secaucus, NJ 07094; phone: 201-348-5300

Eastern Zone: 3 Panasonic Way, 4E-7, Secaucus, NJ 07094; phone: 201-348-7196

Western Zone: 3330 Cahuenga Blvd. West, Los Angeles, CA 90068; phone: 323-436-3608

AW-JACCONSOL-3



Printed in Japan