

7" 2200NIT FIELD MONITOR

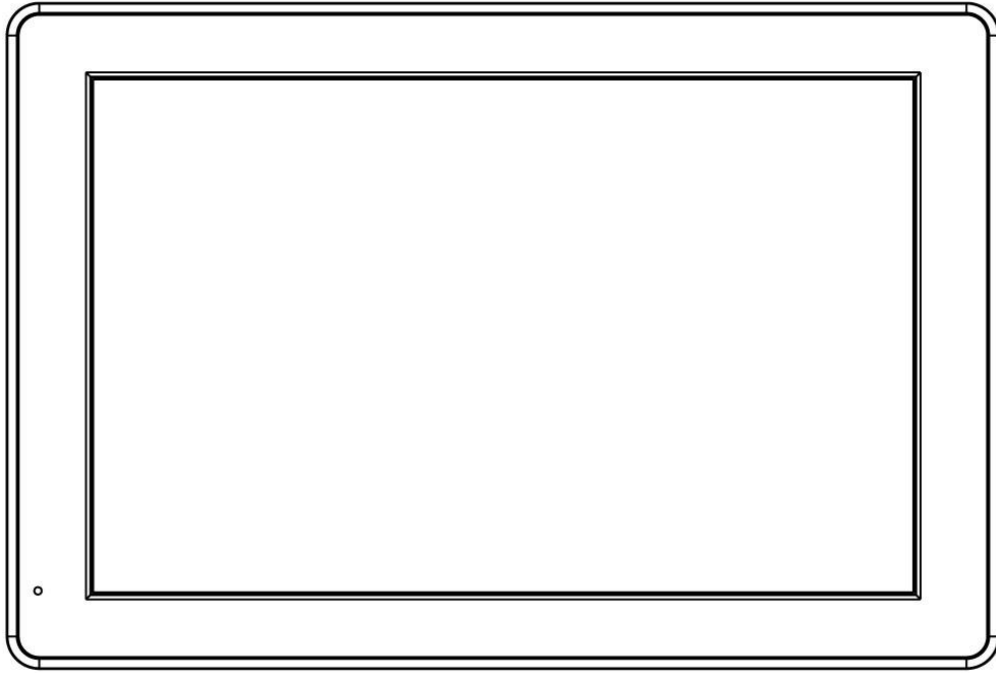

User Manual

CONTENTS

Foreword	1
Cautions	1
Key Features	1
Product Overview	2
Power Supply Way	4
Connection Method and Cautions for Monitor and Camera	5
Installation of Mini Mount Adapter	8
Installation of Sunshade	10
Menu Operation Instruction	11
Menu Interface and Function Instructions	12
How to Import Custom LUT	19
Firmware Update	20
Technical Parameters	21
Trouble Shooting	22

Foreword

Thank you for using our 7- inch 2000nit ultra-bright monitor. Please read this manual carefully before using the unit. Have a great experience!

Cautions

1. Please avoid drop onto the ground and lead to the device broken when move the product.
2. The screen of this product is made of glass, please keep away from injury if the screen is broken.
3. Keep the product away from the heat source. Avoid the prolonged exposures to the sun as the LCD screen will be damaged.
4. To avoid damaging the product, please do not take apart or repair the unit by yourself without the adjustable components in the unit.

- To protect the screen or housing better, please follow these ways as below to avoid the damages:

Please refrain from using the hard objects to hit the screen

Please do not force to wipe the screen or housing

Please do not use the chemical solutions to clean the screen or housing

Please do not spray any detergent on the screen or housing

Please do not write on the screen directly

Please do not stick anything on the screen or housing

Please simply wipe with a clean soft cloth and make sure no water on the screen or housing

Key Features

- FHD 1920x1200 IPS, view details with confidence
- Intuitive button operation, easy to use
- 2000nit ultra brightness, daylight viewable

- Rugged and durable aluminium housing
- Equipped with 4K 60Hz HDMI,3G-SDI (optional) input and output
- Load custom 3D-LUT, preview film look
- HDR monitoring, what you see is what you get
- Waveform, Vector, Histogram and audio meter can moveable horizontally and vertically
- 4-group user switching, quickly access the already set menu
- 3.5mm earphone output for real-time monitoring

Product Overview

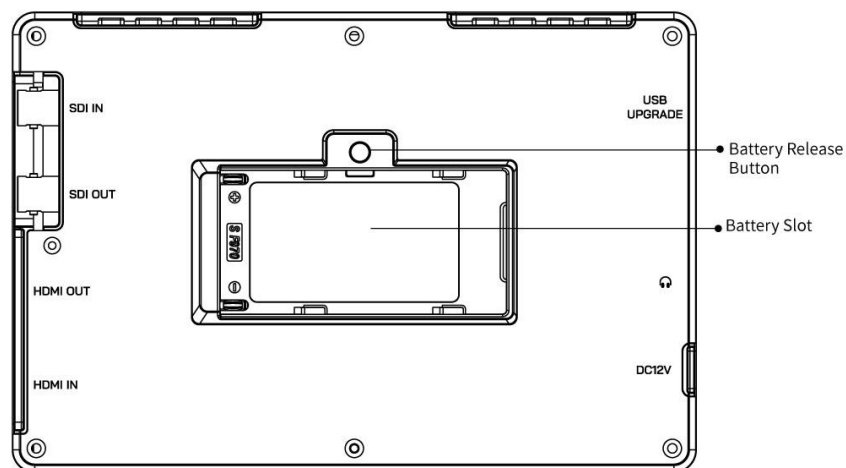
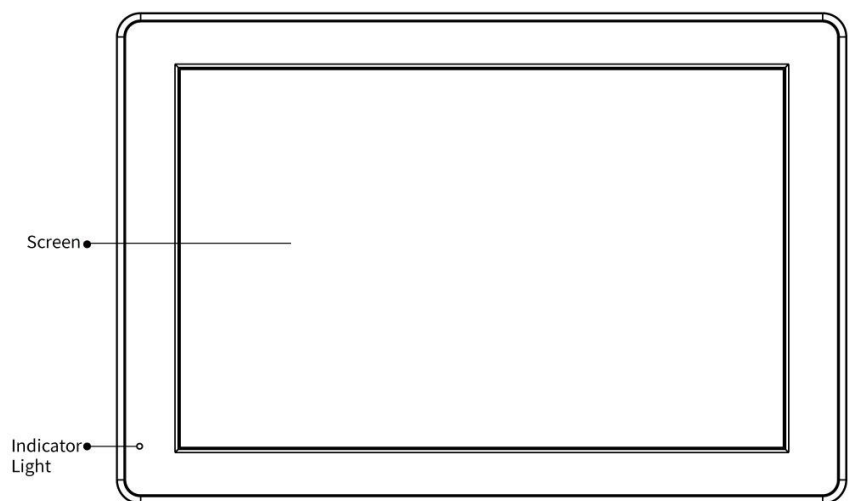

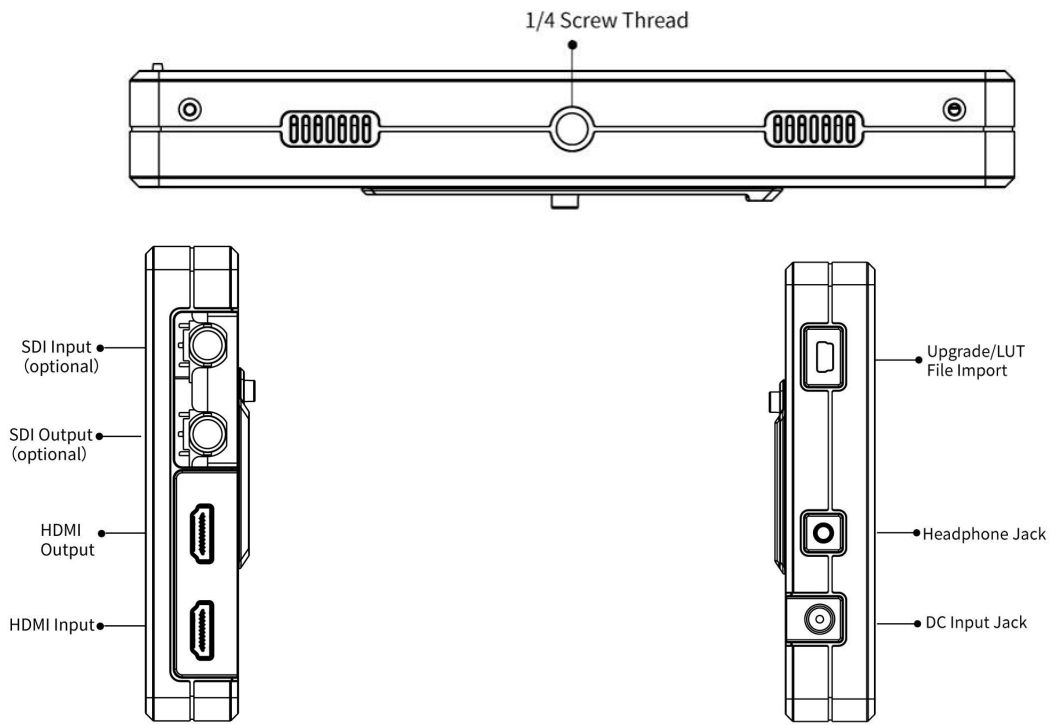

SDI Version:

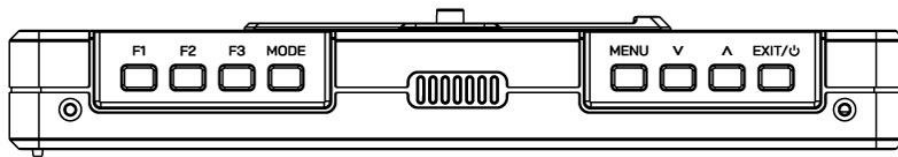

W/O SDI Version:

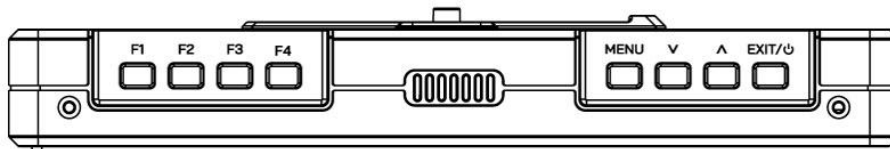

Button	Function when OSD is not displayed	Function when OSD is displayed
F1	Custom button F1	/
F2	Custom button F2	/
F3	Custom button F3	/
MODE (SDI version)	Signal Input Selection	/
F4 (W/O SDI version)	Custom button F4	/
MENU	Display OSD Main	Confirm

	menu	
∨	Decrease the volume or backlight	Select next menu item; Decrease or adjust value of selected parameter
∧	Increase the volume or backlight	Select previous menu item; Increase or adjust value of selected parameter
EXIT/⏻	Power On/Off button; Return/Exit Menu	

Power Supply Way

There are two power supply ways to the monitor:

- A. Barrel (5.5mm outer, 2.1mm inner) at the left side of the monitor, DC 7~24V Input. It is recommend to use 12V/2A power adapter
- B. The rear cover of the monitor is equipped with NP-F battery slot, it can be installed the NP-F series battery

The battery models including F970 F960 F950 F930 F770 F750 F730 F570 F550 F530 and other specifications.

● Installation and remove of battery

1. Insert the battery gently in the direction indicated, then slide it to the left (without releasing). A clicking sound indicates that the battery is securely in place.

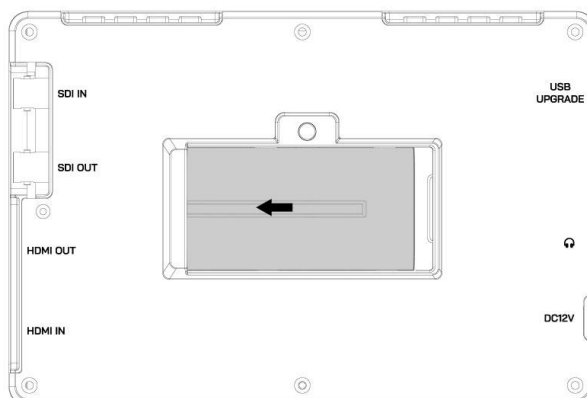

2. To remove the battery, press and hold the battery release button while slide the battery to the right, then remove it.

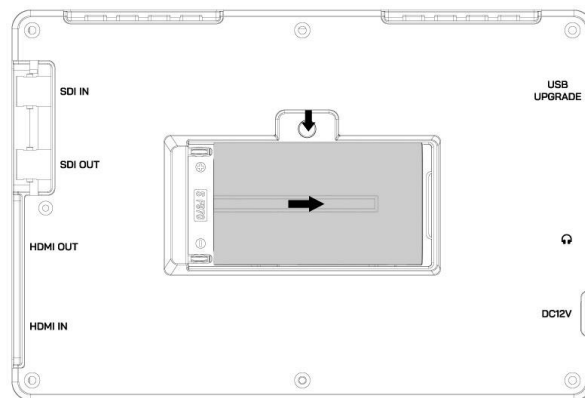

Remark: It is recommended to use standard original F970 batteries. Different specifications of the battery have different capability. The working time for the monitor will be different. Higher capability (working time) will be longer. Please take off the battery from the monitor if you don't use the monitor in a long time.

Connection Method and Cautions for Monitor and Camera

Preparing before connecting

- Ensure that both the camera/camcorder and monitor are turned off
- Check if the HDMI/SDI interface and cables are clean and intact
- Prepare anti-static wristbands or discharge by touching metal object first
- Ensure that the workbench is clean and stable

Connection of HDMI cable

1. Using the accompanied HDMI/Micro HDMI cable to connect the HDMI IN of the monitor and the HDMI Out of the camera (please purchase extra HDMI cable if the HDMI cable is not long enough)
2. Fix the wire to avoid hanging or pulling it
3. Turn on the camera first, and then turn on the monitor. The image of camera viewfinder will be displayed on the screen of the monitor.

Please set it to Auto or 16:9 if the camera is designed with an HDMI output setting function.

4. When shutting down, first turn off the monitor, wait for it to completely shut down, and then turn off the camera.

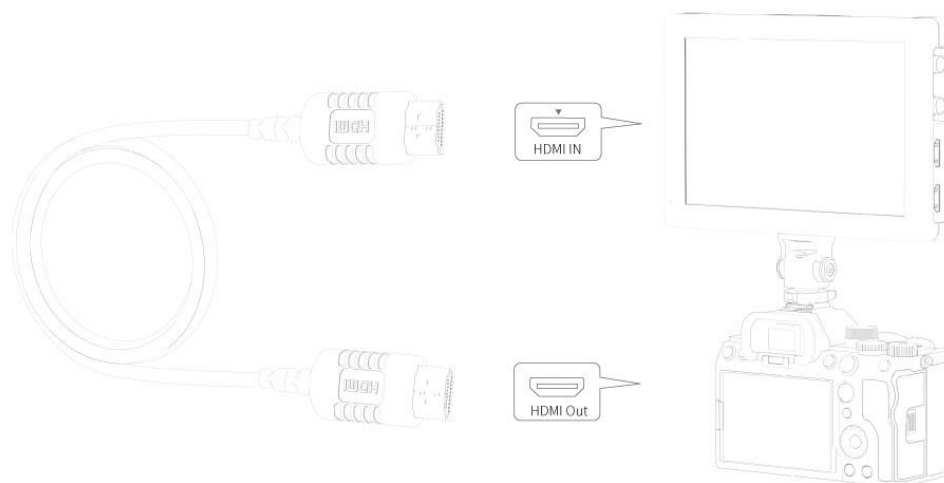

Connection of SDI cable (only for SDI version, available separately)

1. Using the accompanied SDI cable to connect the SDI IN of the monitor and the SDI Out of the camcorder.
2. Fix the wire to avoid hanging or pulling it

3. Turn on the camcorder first, and then turn on the monitor. The image of camcorder will be displayed on the screen of the monitor.
4. When shutting down, first turn off the monitor, wait for it to completely shut down, and then turn off the camera.

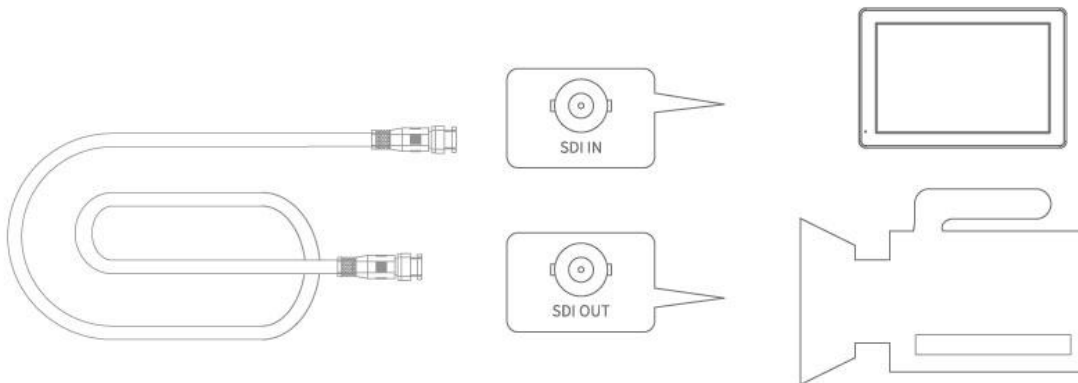

Using cautions

- When moving the device, be careful not to trip over the wires, which may cause hot plugging or unplugging
- Regularly check whether the HDMI/SDI interface and HDMI/SDI cables are worn or blocked by foreign objects
- It is recommended to disconnect when not in use to protect the cables and interfaces

Physical protection measures

- Use HDMI cable fixing clips or brackets
- The wire should have an appropriate margin to avoid being too tight
- Consider using an L-shaped HDMI connector to reduce the pressure on the HDMI interface

-You can use an HDMI adapter to protect the HDMI interface on the camera and avoid damage to the HDMI interface caused by frequent plugging and unplugging

Regular maintenance

-Check if there is dust accumulation on the interface

-Is the equipment voltage stable

-Confirm that the wire is not damaged or bent

-Is the fixing device still securely fastened

-Are all screws securely fastened

These measures can significantly reduce the risk of equipment damage and extend its service life.

Installation of Mini Mount Adapter

1. Select the direction in which the adapter is mounted according to the shape of hot shoe on the camera

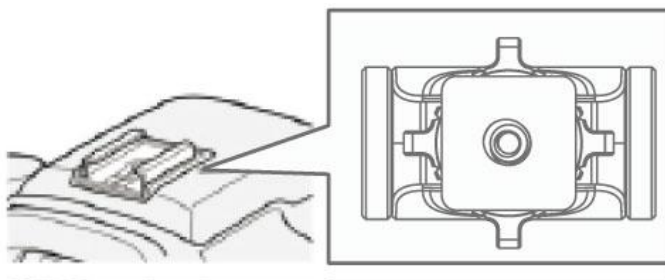

2. Align the 1/4 screw of the adapter with the 1/4 screw hole on the device.

3. Tighten the adjustment knob of the adapter

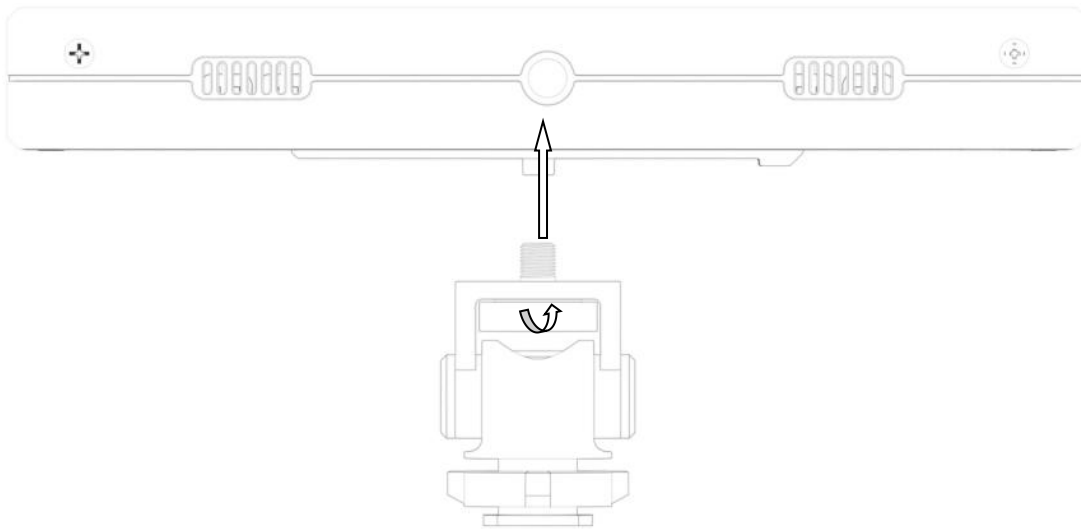

4. ① Fully insert the base of the adapter into the universal hot shoe base in the direction shown in the figure.
- ② Tighten the rotary table of the adapter to fix it on the camera

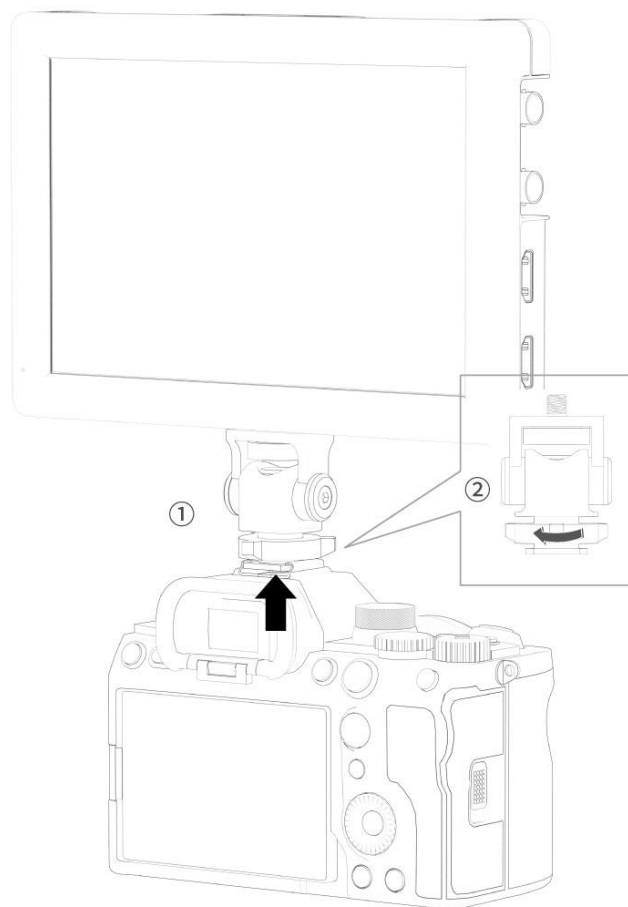

Note: If using a camera with a pop-up built-in flash, please turn off the built-in flash of camera. If the camera is designed with a built-in auto flash function, please turn off this function.

Please remove this device from the camera before using the flash.

Installation of Sunshade

1. Put the monitor on the brackets of the frame, and then gently buckle it (buckle the bottom first then buckle the top) to complete the installation of the frame.



2. Open the sunshade, and then align the Velcro on the inside with the Velcro around the frame, and stick it tightly.



Menu Operation Instruction

After correctly connect to the power supply (red indicator),the monitor default to turn on automatically, the indicator turns Yellow, and then input HDMI signal, the indicator will turn Green from Yellow.

You can also set the power to Manually in menu **System--Power setting**. After setting, you need to long press EXIT/⏻ to turn on the monitor when plug the power supply.

1 When the menu is not displayed, directly press the "∨" or "∧"button to adjust the volume or backlight. You can set in the **Left Right Key**



Set  of menu **User Option** 



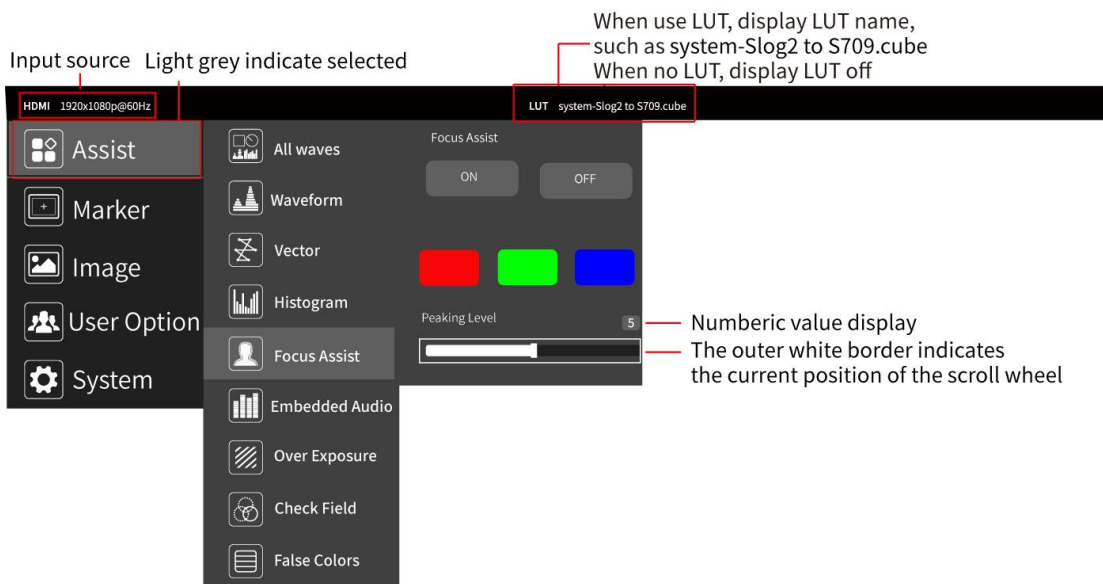

2. Press "MENU" button to enter OSD main menu, press "∨"or "∧"button to select.
3. Press "MENU" button to enter secondary menu, then press "∨"or "∧"button to select items, after selected press MENU button to confirm and enter function menu, press "∨"or "∧"button to select the corresponding function or adjust the parameters, press MENU to confirm finally.
4. Press EXIT/⏻ button to return / exit the menu



Menu Interface and Function Instructions



Assist



 <p>All Waves</p>	<p>On, Off</p> <p>After turning on, waveform, vector, histogram and embedded audio will be shown.</p>
 <p>Waveform</p>	<p>On, Off</p> <p>Mode : RGB, YUV, Y</p> <p>Position X: 0~100 (moving the waveform horizontally)</p> <p>Position Y: 0~100 (moving the waveform vertically)</p> <p>Waves Trans. : Off, 25%, 50%, 75%</p> <p>This essential feature assists with the calibration of professional video cameras. It shows the overall brightness of the image assisting the video professional in correcting exposure. The waveform feature also checks the evenness of the lighting when lighting a chromakey or background.</p>
 <p>Vector</p>	<p>On, Off</p> <p>Position X: 0~100 (moving the Vector horizontally)</p> <p>Position Y: 0~100 (moving the Vector vertically)</p>



	shows how saturated the image is and where the pixels in the image land on the color spectrum.
 <p>Histogram</p>	<p>On, Off</p> <p>Mode: RGB1、RGB2、Y</p> <p>Position X: 0~100 (moving the histogram horizontally)</p> <p>Position Y: 0~100 (moving the histogram vertically)</p> <p>RGB Histogram:It can display the graphic of color tone distribution, can intuitively display the exposure status of the image, and display overlapping histograms in red, green, and blue channels</p> <p>Y Histogram: A quantitative tool to check the picture brightness, display different color for different brightness.</p>
 <p>Focus Assist</p>	<p>On, Off</p> <p>Color : (Red, Green, Blue)</p> <p>Peaking Level : you can adjust the peaking level after turning on (1 ~ 10)</p> <p>It highlights the areas that are in focus so you are able to quickly focus the camera and not miss crucial shots.</p>
 <p>Embedded Audio</p>	<p>On, Off</p> <p>Position X: 0~100 (moving the audio level horizontally)</p> <p>Position Y: 0~100 (moving the audio level vertically)</p> <p>The Audio Level Meters provide numerical indicators and headroom levels.</p>
 <p>Over Exposure</p>	<p>On, Off</p> <p>Exposure Level : you can adjust the exposure level after turning on (10~100)</p> <p>Areas of the image over a certain threshold are filled with a striped pattern to dramatically highlight areas where too much light is falling on the image sensor.</p>

 <p>Check Field</p>	<p>On, Off</p> <p>Mode : Red, Green, Blue, Mono</p> <p>When enabled, hue and saturation adjusted quickly and accurately</p>
 <p>False Colors</p>	<p>On, Off</p> <p>Mode: Normal, ARRI</p> <p>An image that depicts an object in colors that differ from those a photograph (a true color image) would show.</p>
 <p>Time Code</p>	<p>On, Off</p> <p>Mode: LTC, VITC</p>







Marker



 <p>Grid</p>	<p>On, Off</p> <p>Mode: 2x2,3x3,4x4,5x5,6x6,7x7,8x8,9x9, Custom</p> <p>Rows: 2~9</p> <p>Columns: 2~9</p> <p>When selecting Custom, you can custom the rows and columns of the grid</p> <p>Color: Red, Green, Blue, Black, White, Gray</p> <p>The area of the picture can be divided into 4, 9, 16, 25, 36, 49, 64, 81 equal grids.</p>
 <p>Safe Frames</p>	<p>On, Off</p> <p>Mode: 80%, 85%, 90%, 93%, 96%, 2.35:1, 9:16</p> <p>Color: Red, Green, Blue, Black, White, Gray</p>

 Center Marker	On, Off Color : Red, Green, Blue, Black, White, Gray
 Ratio Marker	On, Off Mode: 4:3、 13:9、 14:9、 15:9、 16:9、 1.85:1、 2.35:1、 9:16 Color: Red, Green, Blue, Black, White, Gray Modified Mark : 0~5





Image



 Scan Mode	Under Scan, Over Scan
 Aspect Ratio	Auto, 16:9, 16:10, 4:3, 5:4, 1.85:1, 2.35:1, Full Screen Provides a wide variety of aspect ratio to match different camera anamorphic lenses.
 Anamorphic	On, Off Mode: 1.33X, 1.6X, 2.0X, 2.0X MAG, User Under the User , can be customized (1.20X~2.00X) Allows you to use anamorphic lenses or adapters and see the image unsqueezed, even if your camera does not de-squeeze in camera.
 Image Flip	On, Off Mode: H Flip, V Flip, H_V Flip
 Zoom Mode	On, Off Mode: 2X、 4X、 9X、 16X、 User Under the User , can be customized (100%~200%)



	It is HD signal in any part, an amplification for high quality close-up.
 Image Freeze	On, Off
 P2P	On, Off Enable the filmmaker to check the image from the 1:1 signal source without scaling. This feature is essential for capturing optimum detail.



User Option



 LUT	On, Off After the LUT Switch is turned on, you can use the Lut (SLOG2, SLOG3, LOGC, VLOG) . Lut Import: Confirm Lut Table Show the 4 built-in Lut and the custom load Lut (up to 32) The Lut item is displayed after the Lut Switch is turned on. LUT is a table for quickly looking up and output specific color data. By loading different 3D-LUT tables, it can quickly recombine color tone to form different color styles
 HDR	On, Off Mode: HLG1, HLG2, HLG3 HDR can provide more dynamic range and the details of image, it is better to reflect the visual effects in the real environment.







 <p>Display Adjustment</p>	<p>Backlight: 0~100 Adjust the screen brightness</p> <p>Brightness: 0~100 Adjust the image brightness</p> <p>Contrast: 0~100 Adjustment of the ratio between the brightest and darkest parts of the image . When adjusting, pay attention to the sense of hierarchy in the image. If the proportion is too large or too small, it can cause the image to lose its colorful appearance.</p> <p>Saturation: 0~100 Adjustment of color concentration</p> <p>Tint: 0~100</p>
 <p>Color Adjustment</p>	<p>Display Range: Auto, Limit, Full This feature allows for the selection of a grayscale range. The Limited grayscale range is 16-235, and the Full grayscale range is 0-255. (Grayscale represents changes in image brightness, using varying gray levels to depict brightness in different image areas. In grayscale, brightness increases from black to white, typically denoted by a numerical range from 0 to 255, where 0 signifies black and 255 indicates white, and intermediate numbers indicate varying grayscale levels.)</p> <ol style="list-style-type: none"> 1. If the dark part of the picture lost, the details cannot be seen clearly. For example, the input signal is in the range of 0-255, but the monitor is set Auto or Limit, the brightness of 0-15 and 236-255 is removed, resulting the dark part details unclear. You can set to Full. 2. If the picture is gray, the black part turned gray. For example, the input signal is in the range of 16-235, but the monitor is set Full , resulting the black part turn gray. At this time,you can set to Auto or Limit.

	<p>Color Temp.: 5600K, 6500K, 9300K, User</p> <p>Under the User, the red, green and blue of the image can be adjusted (0~255), made the colors of the image achieve your favorite.</p>
<p></p> <p>Shortcut Key</p>	<p>All Waves, Waveform, Vector, Histogram, Embedded Audio, Center Marker, Safe Frames, Grid, Focus Assist, False Colors, Over Exposure, Anamorphic, Image Freeze, Check Field, Zoom Mode, Image Flip, Aspect Ratio, Ratio Marker</p> <p>To set the shortcut custom buttons on the panel e.g.: enter the main menu, choose User Option --  shortcut key-- F1 to show pop-up function items, select one of them, such as All Waves. The cursor will be changed to gray color after selected.</p> <p>Directly press F1 button of monitor panel to open All Waves</p> <p>Same setting for other shortcut buttons</p>
<p></p> <p>Left Right Key Set</p>	<p>Volume, Backlight</p>



System

<p></p> <p>User Switch</p>	<p>User Switch: 1~4</p> <p>you can save the set menu as 1-4 and can be called directly next time</p>
<p></p> <p>Language</p>	<p>English, 简体中文, Español, Português, Français, Nederlands、Deutsch, 日本語, 繁體中文, 한국어로, русский язык, Italiano</p>
	<p>OSD Time: Off, 15Sec, 30Sec, 45Sec</p>

 OSD Option	<p>Select the display time of the menu on the screen</p> <p>OSD Trans: Off, 25%, 50%, 75%</p> <p>Adjust the transparency of the menu picture background on the screen</p> <p>No Signal: Red, Green, Blue, Black, White, Gray</p> <p>Can be change the background color of screen when no signal</p>
 EDID Settings	<p>EDID Settings: 2.0, 1.4</p> <p>Compatible with resolution of different camera/device</p> <p>Default to 2.0 (if set 1.4 manually, then input 4K60 signal, you need to set to 2.0 again)</p>
 Volume	<p>On, Off</p> <p>0~100</p> <p>Adjusting the speaker volume</p>
 Power Settings	<p>Power on: Auto, Manual</p> <p>Default to Auto. If set Manual, please press EXIT/⏻ key to turn on after the power plug in.</p>
 Reset	<p>Select Reset and press MENU button Confirm, the system back to original setting.</p>
 Firmware Update	<p>Firmware Version (display the version number)</p> <p>Firmware Update</p> <p>Confirm</p>

How to Import Custom LUT

1. USB flash driver format
 - Supports FAT32
2. Max Files Limit Maximum 32 Lut files
3. File requirements

- The LUT file format suffix should be **.cube**
- Single file not exceeded to 7.9Mb
- Support LUT-3D-Size **16,17,32,33,64,65**

Remark: LUT file name must be English or Arabic numerals

4. Steps for loading

4.1 Make sure the USB flash driver correctly connect to the monitor via the accompanied Mini USB to USB cable

4.2 Enter main menu **User Option--LUT-- LUT Import -- Confirm** to load

the monitor will auto detect the USB flash driver

If there is valid lut file in USB flash driver, the monitor will load LUT files and show “[n] name. The [n] shows the quantity number. The “name” should in LUT files’ name. If load successful, the screen will show “complete[n]”. [n] Stands for the quantity number for LUT files should under 32.

PS: How to clear up the imported LUTs?

Insert a empty USB flash driver to the monitor, enter main menu **User Option--LUT-- LUT Import -- Confirm**, the imported LUTs will be clear up.

Firmware Update

We usually do not recommend to upgrade casually.If really need, please connect after-sale or other person to get the relevant upgrade file

1. Use a FAT32 format USB drive , copy the upgrade file to the USB drive and plug it to the USB interface of the accompanied Mini USB to USB cable

2. Turning on the monitor, take the mini USB part of the mini USB to USB cable insert to the mini USB interface of the monitor
3. Enter the menu, select **System--Firmware Update--Confirm**, press MENU key to confirm to upgrade.
4. After loading, the monitor will shut down automatically, please reboot manually
5. Check whether the latest version

Technical Parameters

Panel Size	7" IPS
Resolution	1920x1200 pixels
Dot Pitch	0.07875(W) x 0.07875 (H)mm
Aspect Ratio	16:10
Brightness	2000cd/m ²
Contrast	1200:1
Viewing Angle	80°/80°(L/R) 80°/80°(U/D)
Backlight	LED
Input	SDI (Optional), HDMI
output	SDI (Optional), HDMI
Audio	3.5mm Stereo Headphone
Other Interface	Mini USB (Firmware update/LUT file import)
SDI Support Format	720p (60/59.94/50/30/29/25/24/23.98) 1080i (60/59.94/50) 1080p(60/59.94/50/30/29.97/25/24/24sF/23.98/23.98sF)

HDMI Input / Output Support Format	480i/576i/480p/576p 720p(60/59.94/50/30/29/25/24/23.98) 1080i(60/59.94/50) 1080p(60/59.94/50/30/29.97/25/24/24sF/23.98/23.98sF) 4K 3840×2160p (60/50/30/29.97/25/24/23.98) 4K 4096×2160p (60/50/30/29.97/25/24/23.98)
Input Voltage	DC7~24V
Power Consumption	≦ 18W
Unit Size	182.8x122.8x24 (mm)
Unit Weight	370g(SDI version) 336g(w/o SDI version)
Mount Points	1/4"-20 Thread Point (bottom)
Working Temperature	- 20°C ~ 55°C
Storage Temperature	- 30°C ~ 65°C

Trouble Shooting

1. Only black and white or monochrome picture

- ① please check saturation, brightness & contrast adjustment.
- ② Please check "Check Field" is in black, white or monochrome image or other condition.

2. NO Image after put on the power

- ① Check if signal cable connecting is in good condition, and if monitor is synchronized with the input signal.
- ② Check signal cable connecting, and make sure to use the standard adapter to connect the monitor. If power is supplied by battery, please check if the battery is fully charged.

3. No sound

- ① Check if Volume control does not open, try to increase the volume.
- ② Check the signal input source is normal or not.

- If there are still other problems, please contact with our related technologists.
- ★As we are improving product features and product performance, so if there is any change on the specification without prior notice.