



Products and
accessories

BOSE®
PANARAY®
620M
Multi-Position
Floor Monitor

BOSE® PROFESSIONAL SYSTEMS DIVISION – COMPLETE COMMERCIAL SOLUTIONS

Customer
focus

Acoustic
design

Listen before
you buy

Project
management

Products
and accessories

Installation
services

After sales
services

BOSE

BOSE®

BOSE® PANARAY® 620M Multi-Position Floor Monitor



PRODUCT OVERVIEW

The BOSE® PANARAY® 620M Multi-Position Floor Monitor is a high-performance compact solution that delivers multiple coverage options for a variety of professional and commercial applications. Its unobtrusive design and recessed NL4 connectors allow for easy cable concealment, which reduces clutter on stage. The frequency response and controlled coverage of the 620M floor monitor allow it to be used with many types of sources and applications.

An innovative combination of cabinet shape and unique Bose technology allows this model to be used in almost any type of floor-monitoring application. These include individual mixes, orchestra pits and public speaking engagements. It also can be used for group mixes for stage performances, choirs and almost any other application where common performers require a reference point.*

PRODUCT INFORMATION

Each PANARAY® 620M floor monitor is a full-range device that includes six 2.25" (57mm) mid-high frequency drivers in a proprietary Articulated Array® speaker design, combined with two 5.25" (133mm) woofers. The benefit of this technology is smooth, even coverage throughout the listening area.

Although compact, the 620M floor monitor provides high SPL with a maximum continuous SPL of 113 dB (119 dB peak) and wide bandwidth (70 Hz - 16 kHz). This allows the floor monitor to be used in a variety of different applications, from voice only to full range on both small and large stages.

The 620M floor monitor utilizes the internal passive crossover network, which does not require active equalization.

The 620M floor monitor is made out of molded polyethylene and includes a powder-coated steel grille. The result is a cabinet that is both lightweight and durable.

KEY FEATURES

- Proprietary Articulated Array speaker design provides smooth response and even coverage
- Three-in-one cabinet design covers multiple floormonitor applications
- Wide bandwidth with extension to 70 Hz
- Compact design with integrated handles
- Recessed rear NL4 connectors
- Lightweight, only 22lb (10kg)
- Rear bumper prevents unwanted movement
- Durable molded polyethylene cabinet with a steel grille
- Available in black or white

APPLICATIONS

The PANARAY® 620M Multi-Position Floor Monitor is well-suited for professional installations such as:

- Houses of worship
- Auditoriums
- Performing arts
- Municipal multi-facilities purpose spaces

And small- to medium-sized stage applications such as:

- School performances
- Orchestra pits
- Public speaking/corporate events

DETAILED PRODUCT SPECIFICATIONS

Power Handling ¹	200W
Impedance	8Ω
Sensitivity ² (at 1W @ 1m)	90 dB-SPL
Maximum SPL ³ (pink noise @1m @ rated power)	113 dB-SPL 119 dB-SPL (Peak)
Internal Crossover	250 Hz
Frequency Range ⁴ (± 3 dB)	70 Hz - 16 kHz
Beamwidth	
45° position (individual mix)	Horizontal: 40°; Vertical: 120°
60° position (group mix – deep stage)	Horizontal: 120°; Vertical: 40°
40° position (group mix – shallow stage)	Horizontal: 120°; Vertical: 40°

1-4 See "How our loudspeakers are measured" on page 5.

PANARAY® 620M COVERAGE OPTIONS

An innovative combination of cabinet shape and unique BOSE® technology allows each model to be used in almost any type of floor-monitoring application.

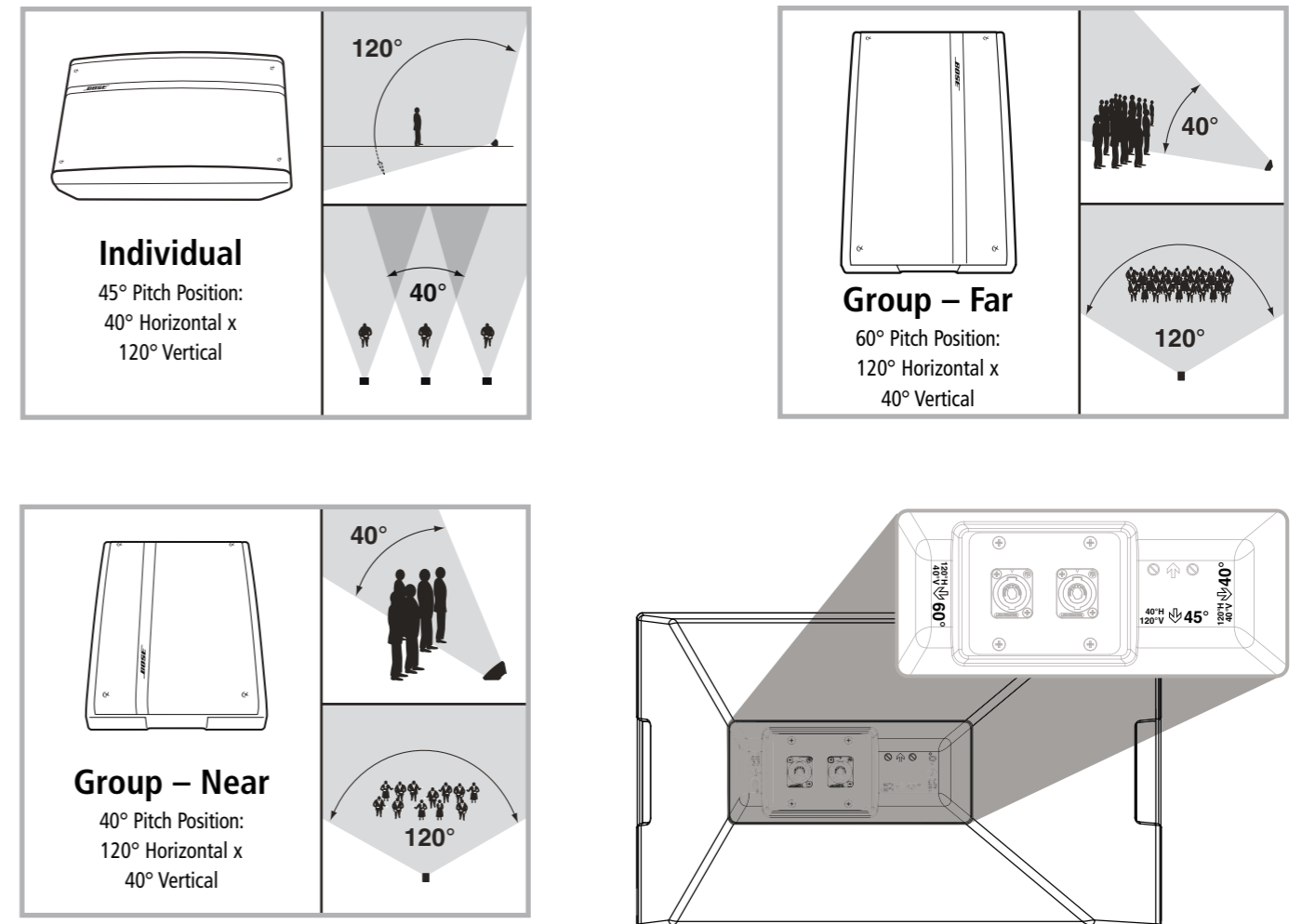

The three coverage options are clearly indicated on the rear of the PANARAY® 620M.

*See next page for coverage illustrations.

Driver complement:

Two 5.25" (133mm) driver
Six 2.25" (57mm) drivers

Construction features:

Each loudspeaker is made of molded textured polyethylene material with a powder-coated steel grille.

Color:

Black or white

Dimensions:

20.6" H x 12.5" W x 10.5" D
(552mm x 318mm x 266mm)

Product weight:

22lb (10kg)

Shipping weight:

28lb (13kg)

Connectors:

Two Neutrik® NL4 connectors wired in parallel

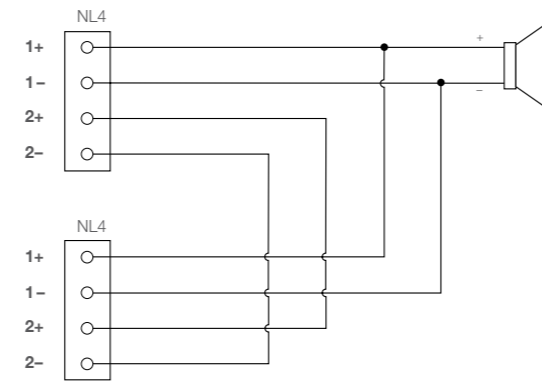
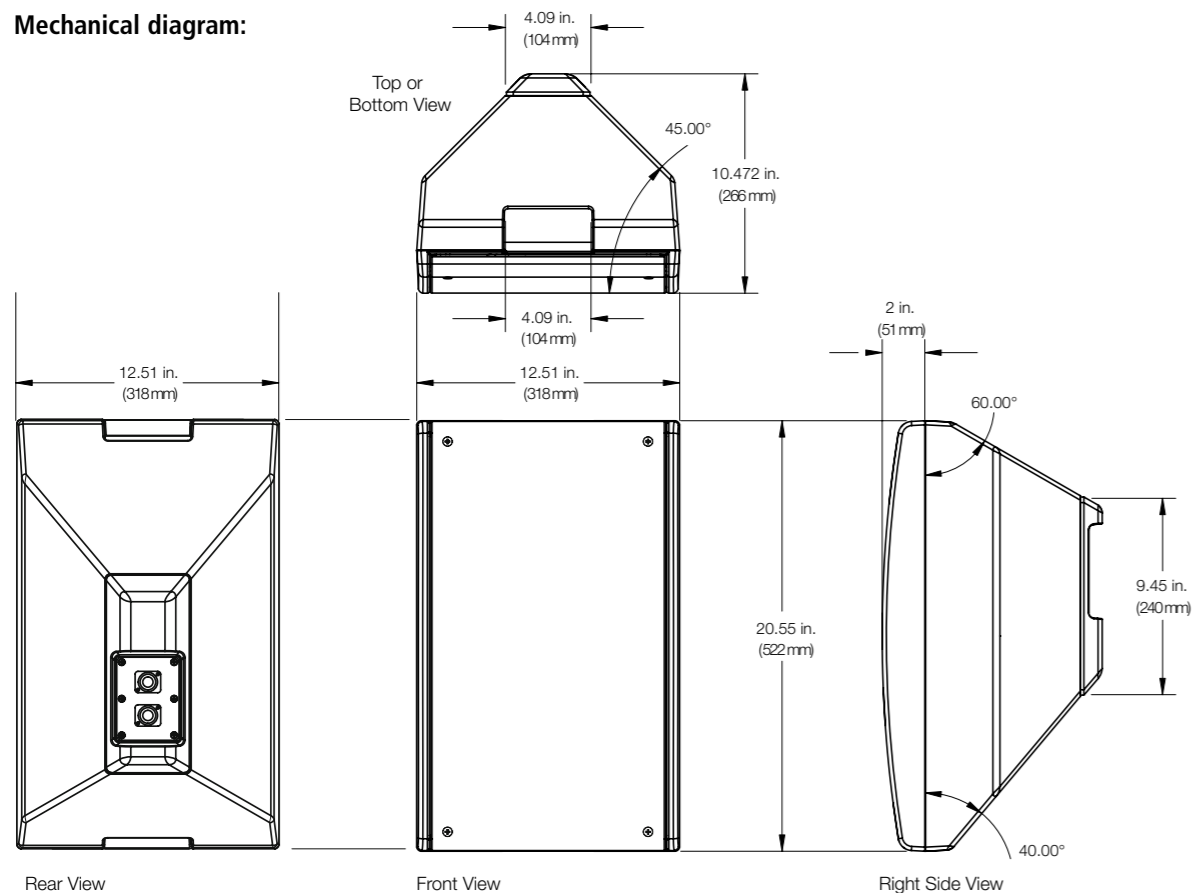
NL4 wiring diagram:**Mechanical diagram:****BOSE® PANARAY® 620M Multi-Position Floor Monitor****ENGINEERS' AND ARCHITECTS' SPECIFICATIONS**

The loudspeaker shall be a multiple driver, full-range speaker. The transducer complement shall consist of two low-frequency drivers of 5.25" (133mm) diameter, mounted symmetrically in pairs, with six 2.25" (57mm) drivers in an Articulated Array® speaker design. The speaker shall have a cabinet shape to enable the floor monitor to be used in three different floor positions.

The multi-position floor monitor shall have a rated nominal impedance of 8 ohms. The loudspeaker system sensitivity shall be 90 dB-SPL in the 70 Hz - 16 kHz frequency range, with measurements referenced to 1W (2.85V) pink noise input at 1m. The dispersion shall be 40°H by 120°V in the individual position, 120°H by 40°V in the group-near position and 120°H by 40°V in the group-far position. The power-handling capacity of the loudspeaker shall be 200W IEC band-limited, from 70 Hz - 16 kHz.

The input connectors of the multi-position floor monitor shall consist of two parallel Speakon® NL4 receptacles. The enclosure of the 620M floor monitor shall be composed of linear, low-density polyethylene. Its outer dimensions shall be 20.6" H x 12.5" W x 10.5" D (522mm x 318mm x 266mm). Its weight shall be 22lb (10kg). The floor monitor is packaged one per carton.

The loudspeaker shall be the PANARAY® 620M Multi-Position Floor Monitor.

TECHNICAL LITERATURE

The PANARAY® 620M Multi-Position Floor Monitor Installation Guide is available at pro.bose.com

SAFETY AND REGULATORY COMPLIANCE

The PANARAY® 620M Multi-Position Floor Monitor complies with ANSI/EIA 636, Loudspeaker Safety EMC Directive 89/336/ Article 10 (1) of the compliance with EN50081-50082-1, as signified by the CE mark.

LIMITED WARRANTY

The PANARAY® 620M Multi-Position Floor Monitor is covered by a transferable 5-year limited warranty.

PRODUCT CODES

PANARAY® 620M	Black	PC 039917
PANARAY® 620M	White	PC 039918

REPLACEMENT PARTS

620M grille kit	Black	PN 293305-001
620M grille kit	White	PN 293305-002

HOW OUR LOUDSPEAKERS ARE MEASURED**1. Power Handling**

Full-bandwidth pink noise, meeting the IEC Standard #268-5, is applied to the loudspeaker and amplified to a level at the loudspeaker terminals corresponding to the power handling of the loudspeaker. The loudspeaker must show no visible damage or measurable loss of performance after 100 hours of continuous testing.

2. Sensitivity

Full-bandwidth pink noise is applied to the loudspeaker and amplified to a level at the loudspeaker terminals corresponding to 1 watt as referenced to the nominal impedance. The average sound pressure level (dB-SPL) is measured at 1 meter from the speaker ground plane in an anechoic environment.

3. Maximum SPL

Full-bandwidth pink noise is applied to the loudspeaker and amplified to a level at the loudspeaker terminals corresponding to the long-term rated power handling of the speaker. The average sound pressure level (dB-SPL) is measured at 1 meter from the speaker ground plane in an anechoic environment.

4. Frequency Range

Sine waves are injected into the loudspeaker, and the level is adjusted to 1 watt, as referenced to the nominal impedance, and the level measured at 1 meter. Resulting graph is smoothed by 0.05 octave-band.

All information subject to change without notice. © 2006 Bose Corporation. BOSE®, PANARAY™ and ControlSpace™ are trademarks of Bose Corporation. Other marks are the property of their owners.

