

**SWIT®**

**SWIT Electronics Co., Ltd.**

Model: CM-S73H

---

7" Full HD High Bright LCD Monitor

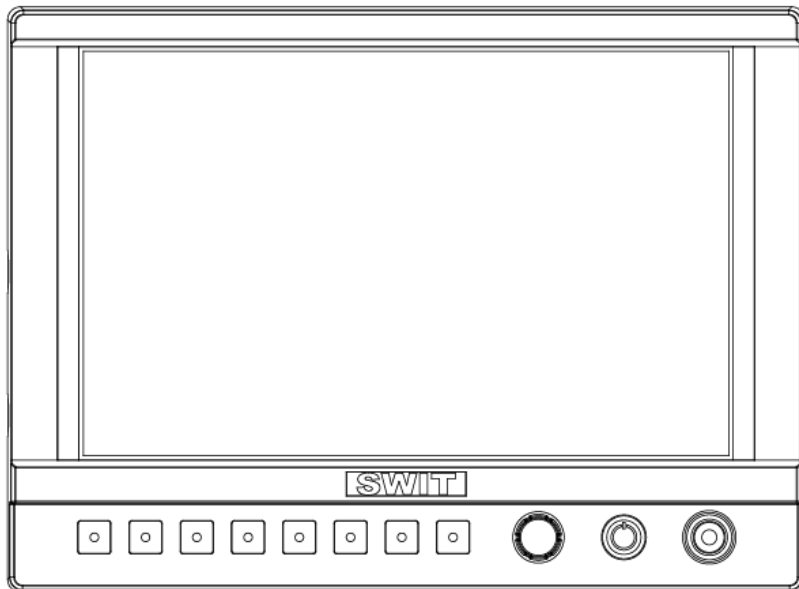

# User Manual

Ver: A

Please read this User Manual  
throughout before using

# Preface

---

1. All internal technologies of this product are protected, including device, software and trademark. Reproduction in whole or in part without written permission is prohibited.
2. All brands and trademarks of SWIT Electronics Co., Ltd. are protected and other relative trademarks in this user manual are the property of their respective owners.
3. Due to constant effort of product development, SWIT reserves the right to make changes and improvements to the product described in this manual without prior notice.
4. The warranty period of this product is 2 years, and does not cover the following:
  - (1) Physical damage to the surface of the products, including scratches, cracks or other damage to the LCD screen or other externally exposed parts;
  - (2) The LCD dot defects are not over three;
  - (3) Any damage caused by using third-party power adaptors;
  - (4) Any damage or breakdown caused by use, maintenance or storage not according to the user manual.
  - (5) The product is disassembled by anyone other than an authorized service center.
  - (6) Any damage or breakdown not caused by the product design, workmanship, or manufacturing quality, etc.

\* Any sales personnel have no rights to provide additional warranty.
5. For any suggestions and requirements on this product, please contact us through phone, fax, Email, etc.

---

## **SWIT Electronics Co., Ltd.**

Address: 10 Hengtong Road, Nanjing Economic and Technological Development Zone,  
Nanjing 210038, P.R.China

Phone: +86-25-85805753

Fax: +86-25-85805296

Email: [contact@swit.cc](mailto:contact@swit.cc)

Website: <http://www.swit.cc>

# Maintenance

---

## Warning

1. In order to reduce the risk of fire and electrical shock, do not lay this product in rain or damp places.
2. Please keep away from the strong magnetic field; it may cause the noise of the video and audio signals.

## The power

1. Please use the power adapter provided or recommended by the manufacturer in order to avoid damage.
2. For a third party power adapter, please make sure the voltage range, supplied power, and polarity of power lead are fit.
3. Please disconnect the power cable under the following situations:
  - (A). If you do not operate this monitor for a period of time;
  - (B). If the power cable or power adaptor is damaged;
  - (C). If the monitor housing is broken.

## The monitor

1. Please don't touch the screen with your fingers, which would probably deface the screen.
2. Please don't press the screen; the LCD is extremely exquisite and flimsy.
3. Please don't lay this product on unstable place.

## Cleaning

1. Please clean the screen with dry and downy cloth or special LCD cleanser.
2. Please do not press hard when cleaning the screen.
3. Please do not use water or other chemical cleanser to clean the screen.  
The chemical may damage the LCD.

## Contents

---

Preface .....	2
Maintanance .....	2
Contents .....	3
Packing list.....	4
Introduction .....	4
Operation Instruction .....	5
Screen display.....	6
Zoom-in and mapping .....	7
Main Menu .....	9
Specification.....	17
Trouble shooting .....	18

# Packing list

---

CM-S73H offers the standard package and luxury package for option.

## Standard package includes:

- 1、 User manual
- 2、 Warranty card
- 3、 Cold shoe / Screw ball head
- 4、 D-tap to lockable DC cable
- 5、 S-7006 (U/F/D/C) /S-7006(A/S)

## Luxury package includes:

- 1、 User manual
- 2、 Warranty card
- 3、 Articulating arm trestle
- 4、 AC-DC power adaptor
- 5、 Power cable
- 6、 LCD protective film
- 7、 BNC SDI cable
- 8、 HDMI cable
- 9、 D-tap to lockable DC cable
- 10、 S-7006 (U/F/D/C) / S-7006(A/S)
- 12、 Carrying case

## Introduction

---

CM-S73H adopts TFT LCD panel, with resolution 1920×1200 and wide viewing angle H160°/V120°. It supports 2 x 3GSDI (Level A/B), 1 x HDMI2.0 (4K display) input. It also supports 1x 3GSDI, 1 x HDMI and 1 x analog audio loop through output.

### Features:

- 3000nit super high brightness
- Support HDMI 4K display
- Camera Log conversion
- Support 3DLut cube
- Support multiple Aspect Ratio and scan modes
- Support multiple Marker selection (Marker, Safety Area)
- Powerful audio and video analysis functions
- Support multiple functions user-defined (Source ID, function keys)
- Multiple power supply methods to meet different requirements
- USB firmware upgrade

# Operation Instruction

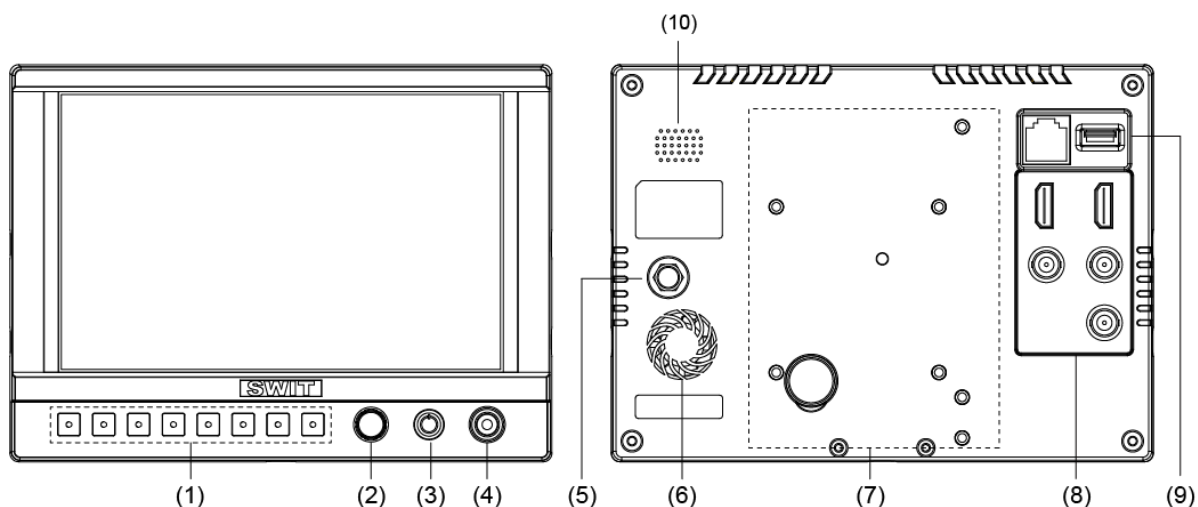

## (1) Button

Source: Signal selection button (HDMI、SDI1、SDI2)

User definable function keys (F1~F3)

User can set F1~F3 keys to corresponding function for quick operation according to their needs.

For example: User can set F1 to “Focus Assistant”, and press F1 to directly switch the focus assistant parameter, the sequence is “Red→Blue→Off”.

Quick function keys support multi definition, for details please refer to “4.Function key settings” in the “MENU” section.

BACKLIGHT: Quickly adjust the brightness level. There are four levels of “Off”, “Low”, “Medium” and “High” optional.

Note: When set to “Off”, the user can adjust the “Backlight” parameter value under “Picture” submenu according to the requirements.

DISPLAY: Press “DISPLAY” to turn on or turn off relevant status information, audio and video analysis assistant Pattern.

When main menu is activated, press “DISPLAY” to quit menu.

## (2) Main menu settings

When no menu is opened, user can directly press the knob, and open the main menu on the left top of the screen;

Rotate the knob, select corresponding submenu; the corresponding item is highlighted in yellow;

Press the knob, enter the submenu;

Rotate the knob to select items; the corresponding item is highlighted in yellow;

Press the knob, the parameter of the item is highlighted in yellow;

Rotate the knob to select the parameter and press to save the settings.

## (3) POWER: Power on/off

## (4) PHONE: 3.5mm earphone socket, for SDI/HDMI embedded audio and analog audio monitoring.

## (5) DC 6.5-17V IN: Round head DC power supply interface (Outer: Negative, Inner: Positive)

## (6) Silent fan

## (7) Battery mount connector

## (8) Video Signal Interface

HDMI-IN: HDMI input (HDMI-A connector)

HDMI-OUT: HDMI output (HDMI-A connector)

SDI-IN1: 3G/HD/SD SDI input (BNC connector)

SDI-IN2: 3G/HD/SD SDI input (BNC connector)

SDI-OUT: 3G/HD/SD SDI output (BNC connector), the monitor choose fixed SDI-IN1 signal to loop output.

(9) External interface control

GPI: GPI control socket

USB: For firmware upgrade

(10) Speaker

Monitor HDMI, SDI embedded audio and analog audio monitoring. (when connecting 3.5mm audio output, the speaker is off).

### • Screen display

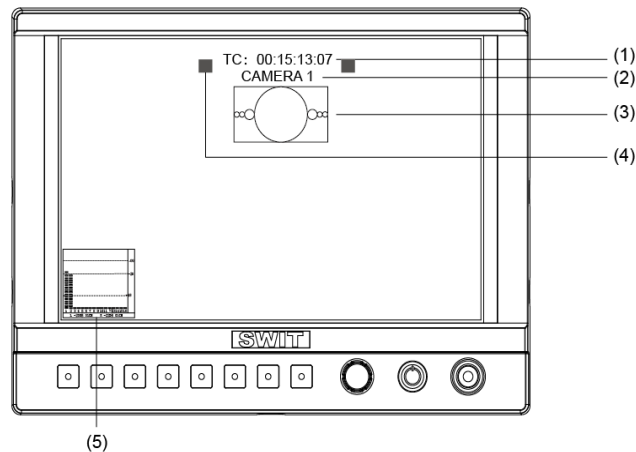

(1)、Timecode (SDI)

Under SDI input, it can display Timecode. If no Timecode information is detected, it will be displayed as “TC: UNLOCKED”.

User can set function keys F1~F3 as “Timecode” to turn on or off this function

(2)、UMD

Display the source title. Set up the UMD under “UMD” submenu.

(3)、AFD (SDI)

User can set function keys F1~F3 as “AFD” to turn on or off this function. If no relevant information is detected, it will be displayed as “AFD: UNLOCKED”.

(4)、Soft Tally

When connected with TALLY control devices and set TALLY port in GPI, the screen will display soft TALLY signal, flashing in Red, Green or Yellow. Refer to “Main Menu—5. GPI”.

(5)、Audio

Monitor the audio information. User can set function Keys F1~F3 as “Audio” to turn on or off this function

The relevant parameters like position, audio channels and blending, etc can be changed under “Audio” submenu.

## • Zoom-in and mapping

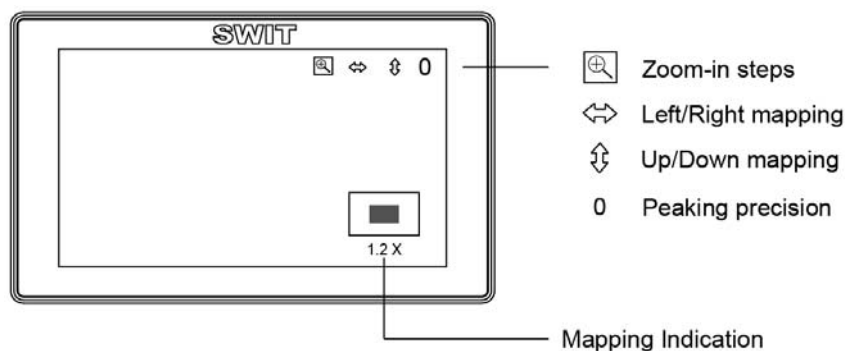

Set “Zoom-in” to function keys, and enable zoom-in mode, the OSD displays as above.

### 1、 Zoom-in steps operation

Scroll the menu key up and down you can quickly zoom in the video by the following rates: 1.2x, 1.5x, 1.8x, 2.0x, 2.4x, 2.6x, 2.8x, 3.0x, without black waiting. The zoom-in indication window is displayed on bottom right of the screen.

Press the menu key to switch to Left/Right mapping function, and press again to switch to Up/Down mapping, and so on.

### 2、 Left and Right mapping

Press Menu key, the ⇔ button is highlighted. Scroll the Menu key up and down to move the video left and right.

### 3、 Up and Down mapping

Press Menu key again, the ⇕ button is highlighted. Scroll the Menu key up and down to move the video up and down.

### 4、 Peaking precision adjust

Press Menu key again, the peaking precision number is highlighted. Scroll the Menu key up and down to adjust the peaking focus assist precision from 0-9.

### 5、 Mapping indication window

Under zoom-in mode, the mapping indication window is displayed on bottom right of the screen, and indicates the zoom-in rate, up/down/left/right position.

## Introduction of audio and video functions

### ◆ 16-ch embedded audio meters

Under 3G/HD/SD SDI, it displays 16 channels embedded audio meters. Under HDMI, it displays 2 channels embedded audio meters. The audio meter is green, and will turn yellow when audio exceeds -20dB, and turn red when audio exceeds -9dB.

### ◆ Audio alarm

If the embedded audio value is too low or no embedded audio, it will display “MUTE” or “UNLOCKED” in the audio bar.

### ◆ Time code (SDI)

Under SDI input, it can display the SMPTE time code (VITC1, VITC2 or LTC) on the top of the screen, which is used extensively for synchronization, and for logging and identifying material in recorded media. If no Time code information is detected, it will be displayed as “UNLOCKED”.

◆ **Internal Color Bar**

Under SDI and HDMI input, it has 100% internal color bar which helps to analyze the monitor color and adjust the display parameter.

User can set function Keys F1~F3 or GPI pins as “color bar” to turn on or off this function.

◆ **Peaking focus assist (red/blue switch)**

The Peaking focus assist function is to mark the sharpest edges of the image with red or blue color under SDI and HDMI input, for users to check if the subjects are focused.

User can set function Keys F1~F3 or GPI pins as “Focus Assist” to turn on or off this function.

◆ **Zebra stripes**

Zebra Stripes are used to check if the image is over exposed or not by showing black and white lines on the monitor. It is considered over exposed when luminance value exceeds 90%.

User can set function Keys F1~F3 or GPI pins as “Zebra” to turn on or off this function.

◆ **Freeze Frame**

The freeze frame is to capture and display the current broadcast frame.

User can set function Keys F1~F3 or GPI pins as “Freeze Frame” to turn on or off this function

◆ **R/G/B/Mono**

R/G/B/Mono is to display only the blue/red/green primary signal or the luminance signal only so as to monitor the image noise.

User can set function Keys F1~F3 or GPI pins as “R/G/B/Mono” to turn on or off this function.

◆ **False Color**

The false color is used to aid in the setting of camera exposure. Under false color mode, there’s a color chart on the bottom of screen for reference. The color from the dark to the bright will be displayed as blue, cyan, green, yellow, orange and red in a consecutive way. User can set function Keys F1~F3 or GPI pins as “False color” to turn on or off this function.

◆ **AFD (SDI)**

It is the abbreviation of active format description. AFD is to display the SDI embedded AFD information graphically on the screen.

◆ **H/V Delay (SDI)**

Under SDI input, H/V Delay can be used to display line/field blanking signal, and to observe the horizontal and vertical synchronous signal.

◆ **Image flip**

◆ Horizontal, vertical, horizontal and vertical two-way image flip function.

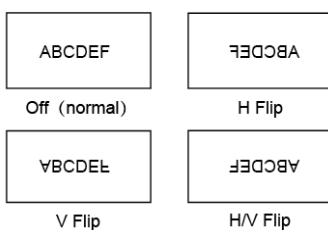

# Main menu

CM-S73H has OSD to adjust the parameters and settings, for example: Picture, color temp., function keys, etc.

1. Press “MENU” button, the main menu will popup from the left top of the screen. The selected main menu highlights in yellow.

Main Menu	Status
Exit&Status	HDMI XXX
Picture	User Profile XX
Color Temp	Color Temp XXXX
Function Key	Scan Mode XXX
GPI	Freeze Frame XX
UMD	Odd/Even Frame XX
Marker	F1 XX
Audio	F2 XX
Vector	F3 XX
Waveform	F4 XX
Display	F5 XX
System	F6 XX
Color Measure	System Version XX
OSD	
VGA	
Key Inhibit	

2. Revolve “MENU” to select submenu, the selected submenu highlights in yellow, press “MENU” to apply and enter into the selected submenu’s items.

3. Revolve “MENU” to select the item which needed to adjust, press “MENU”, the selected item and its parameters will be highlighted in yellow.

Main Menu	Marker
Exit&Status	Exit
Picture	Marker < XXX >
Color Temp	Marker Select < 15:9 >
Function Key	Safety Area < XXX >
GPI	Fit Marker < XX >
UMD	Center Marker < XX >
Marker	Marker Color < XX >
Audio	Marker Ourside < XX >
Vector	
Waveform	
Display	
System	
Color Measurement	
OSD	
VGA	
Key Inhibit	

4. Revolve “MENU” to change the selected item’s parameter, press “MENU” to apply and save the settings.

5. Revolve “MENU” to select “Exit”, press “MENU” to quit submenu. Select “Exit & Status” under the Main Menu and press to quit Main Menu.

Notice:

- \* The items in gray can not be set up.
- \* If there is no operation under the set time, the menu will automatically save settings and quit.
- \* If the key inhibit function is turned on, except key inhibit function, all other items are in grey. Please turn off the key inhibit function to adjust the items.

Submenu introduction (the default values are marked with underline )

### 1. Exit & Status

Displays the current status, the details are as down below:

Exit&Status	—	HDMI* <sup>1</sup>	1080p@50Hz
	—	User Profile	Factory
	—	Color Temp	6500K
	—	Scan Mode	Normal
	—	Freeze Frame	Off
	—	Odd/Even Frame	Off
	—	F1* <sup>2</sup>	Time code
	—	F2	Focus Assist
	—	F3	Zebra
	—	F4	Max Backlight
	—	F5	Freeze Frame
	—	F6	Scan Mode
	—	System Version	VXXX-XX

\*1 Display the current video signal and format

\*2 Display the current function keys setup

### 2. Picture

To adjust picture parameters

Picture	—	Exit	
	—	Contrast	0-100, <u>50</u>
	—	Brightness	0-100, <u>50</u>
	—	Saturation	0-100, <u>50</u>
	—	Sharpness	50
	—	Tint	50
	—	Backlight	0-100, <u>50</u>
	—	Aspect Ratio	<u>Auto</u> ,4:3,16:9,Full
	—	Scan Mode	<u>Normal</u> ,Native
	—	Zoom Mode	<u>Off</u> ,On
	—	Scaling Position	Center
	—	Flip Mode	<u>Off</u> ,H Flip,V Flip,H/V Flip
	—	Freeze Frame	<u>Off</u> ,On

### 3. Color Temp

To select different color temperature or setup user-defined color parameters.

Color Temp	—	Exit	
	—	Gamma	2.2, <u>2.4</u> ,2.6
	—	Color Temp	<u>6500K</u> ,5600K,9300K,3200K,User
	—	Red Gain	0-255,128
	—	Green Gain	0-255,128
	—	Blue Gain	0-255,128
	—	Red Bias	0-255,128
	—	Green Bias	0-255,128
	—	Blue Bias	0-255,128

\* Only “Color Temp” is set to “User”, the Red/Blue/Green Gain or Red/Blue/Green Bias can be adjusted.

## 4. Function key

To define the F1~F3 function keys

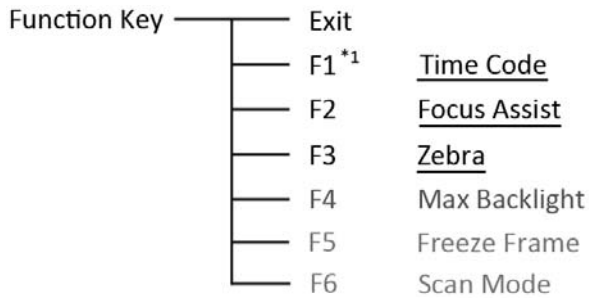

\*1 Function keys F1-F3 can be set as the down below functions:

Time code, Zebra, Audio Bar, False Color, AFD, H/V Delay, R/G/B/Mono, Marker, Color Bar, UMD, Audio Alarm, Focus Assist, Aspect Ratio, Scan Mode, Zoom Mode, Mute, Freeze Frame, Flip Mode, Color Temp.

For example: Set F3 to “R/G/B/Mono” under “Function key” submenu. User can press F3 on the front panel to adjust the parameters of “R/G/B/Mono”, and the “R/G/B/Mono” will change and follow the sequence: Blue Only →Red Only →Green Only →Mono →Off.

## 5. GPI

User can set GPI pins 1-4 to relevant functions to turn on or off this function.

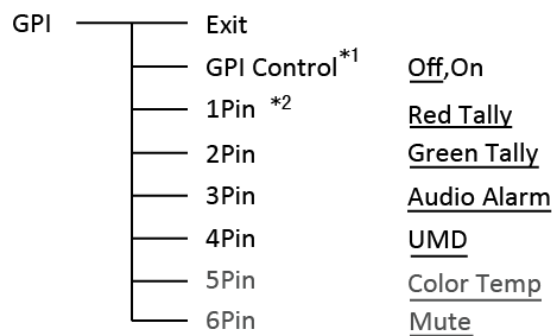

\*1 When “GPI control” is set to “On”, the monitor can be operated through external GPI control unit.

\*2 The GPI pins can be set to the down below functions:

Red Tally, Green Tally, Yellow Tally, Aspect Ratio, Scan Mode, Zoom Mode, Mute, Freeze Frame, Flip Mode, Color Temp, Time code, Zebra, Vector, Audio Bar, False Color, AFD, H/V Delay, R/G/B/Mono, Marker, Color Bar, UMD, Audio Alarm, Max backlight, Focus Assist.

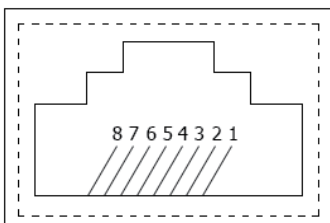

Pin	1	2	3	4
GPI	GPI_1	GPI_2	NC	GPI_3
Pin	5	6	7	8
GPI	GPI_4	NC	NC	GND

When connecting the GPI pin with ground, the setted function will be turned on, and goes out when disconnecting.

Example 1: Under “GPI” submenu, set “GPI control” to “On”, set “2 Pin” to “Red Tally”, when the pin 2 of the external GPI control unit is connected with ground, the Tally light will display on the front panel which will flashes in red around every second. When disconnected, the monitor will not display tally light information.

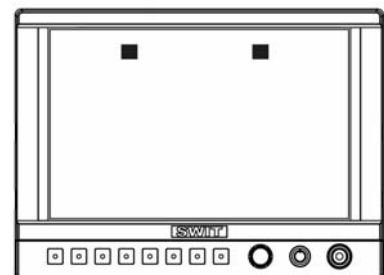

Example 2: Under “GPI” submenu, set “GPI control” to “On”, set “4 Pin” to “Scan Mode”, when the pin 4 of the external GPI control unit is connected with ground, the Scan mode will change and follow the sequence: “Normal” →”Overscan”→”Native” .

## 6. UMD

UMD	Exit	
	RS485 Address	1
	Position	<u>Top</u> ,Bottom
	Size	Normal
	Color	<u>Red</u> ,White,Black,Blue,Green,Yellow
	Display Type	Source ID
	Baud Rate	38400
	Parity	Even
	Serial Port	RS485
	Source ID	<u>CAMERA 1</u>

Set "UMD":

(1) Select "Source ID"

(2) The underline flashes as a reminder on the bottom of the first letter. Revolve "MENU" to select the letters; the letter will follow the sequence of the down below if clockwise revolved:

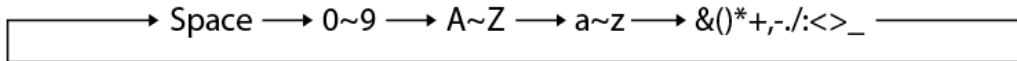

(3) Press "MENU" to save the current settings letter and then start to set the next letter.

(4) Repeat step (2) and step (3), max 8 letters are supported.

(5) Press "Exit" to quit and save the settings.

## 7. Marker

Marker	Exit	
	Marker	<u>Off</u> ,On
	Marker Select	Off,4:3,13:9,14:9,15:9,16:9,1.85:1, <u>2.35:1</u>
	Safety Area	Off,80%,85%,90%, <u>93%</u> ,95%
	Fit Marker *1	<u>Off</u> ,On
	Center Marker	Off, <u>On</u>
	Marker Color	<u>White</u> ,Red,Green,Blue,Black,Gray
	Marker Outside	Off, <u>Gray</u> ,Black

\*1 When "Fit Marker" is "Off", the size of safety area is benchmarked against the actual display screen, accounting for 80% ~ 95% of actual display screen. When "Fit Marker" is "On", the size of safety area is benchmarked against the area inside the scales marker, accounting for 80% ~ 95% of the area inside the scales marker.

**Example:**

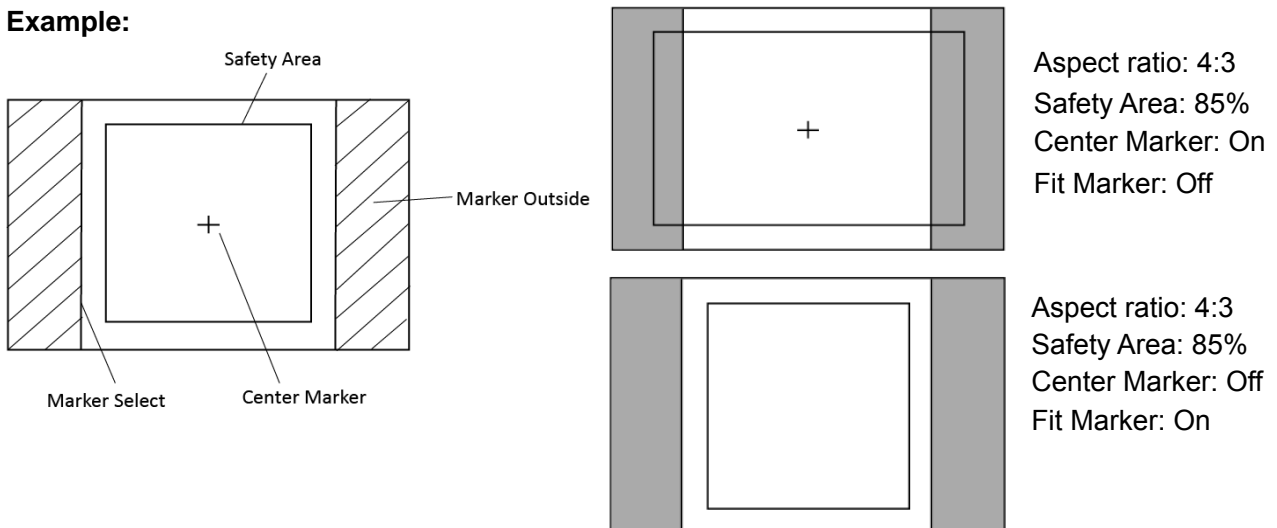

## 8. Audio

Audio	Exit	
	Audio Bar	<u>Off</u> ,On
	Bar Frame *1	Off, <u>On</u>
	Bar Position	<u>Top Right</u> ,Bottom Left,Bottom Right,Top Left
	Bar Blending	<u>Low</u> ,Off,High
	Audio Alarm *2	<u>Off</u> ,On
	Select Channel *3	<u>Channel 1-2</u> ,1-8,1-16
	Left Channel *4	CH1-CH16, <u>CH1</u>
	Right Channel	CH1-CH16, <u>CH2</u>

\*1 When "Bar Frame" is set to "Off", only the audio meter will be displayed.  
When "Bar Frame" is set to "On", frame and real-time audio value will be displayed.

\*2 Select Channel  
Under HDMI signal, channel1-2 can be selected.  
Under SDI signal, channel 1-2, 1-8 and 1-16 can be selected.

\*3 When "Audio Alarm" is set to "On", if no embedded audio is detected, the audio bar will display "UNLOCKED". If the audio value is too low, the audio bar will display "MUTE".

\*4 Audio channels can be selected to output according to the requirements.  
When the current "Select Channel" is set to "Channel1-2", the left channel and right channel output can be selected from Channel1 or channel 2.

When the current "Select Channel" is set to "Channel1-8", the left channel and right channel output can be selected from Channel1 to channel 8.

When the current "Select Channel" is set to "Channel1-16", the left channel and right channel output can be selected from Channel1 to channel 16.

In audio bar, the left channel information will be in green, and the right channel information will be in red.

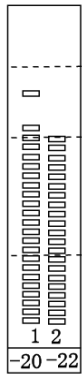

Channel 1~2

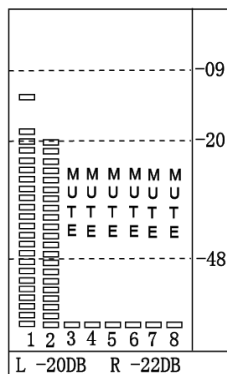

Channel 1~8

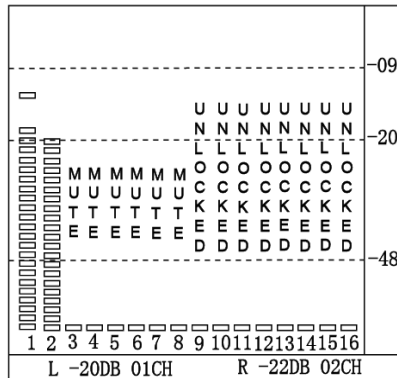

Channel 1~16

## 9. Display

Display	Exit	
	Waveform	Off
	Audio Bar	<u>Off</u> , On
	Vector	Off
	Zebra	<u>Off</u> , On
	Focus Assist	<u>Off</u> , Blue, Red
	Time Code	<u>Off</u> , On
	Histogram	Off
	False Color	<u>Off</u> , On
	AFD	<u>Off</u> , On
	H/V Delay	<u>Off</u> , On
	R/G/B/Mono	<u>Off</u> , Blue Only, Red Only, Green Only, Mono
	Color Bar	<u>Off</u> , On
	Marker	<u>Off</u> , On
	UMD	<u>Off</u> , On

## 10. System

System	Exit	
	Recall Profile	<u>Factory</u> , User1, User2, User3
	Save Profile	<u>User1</u> , User2, User3
	EDID Switch	<u>EDID 2.0</u> , EDID 1.4
	Odd/Even Frame	Off
	Source Scan *1	On, Off
	Logo *2	<u>On</u> , Off
	Green Mode	Black Backlight
	Idle Duration	2Hours
	Update Driver *3	<u>No</u> , Yse
	Update Kernel *4	<u>No</u> , Yes

### \*1 Source Scan

When set to "On", after turn on the monitor, the signal will be inspected and follow the sequence of "SDI1→SDI2→HDMI".

For example: if channel is selected to SDI1, SDI1-IN has no input, and HDMI has input. When turn on the monitor, after automatic inspection, SDI1 has no recognized signal, and HDMI has recognized signal, then the input signal will be HDMI.

When set to "Off", update model will not be supported.

### \*2 Logo

When powered on, the screen will display SWIT logo.

### \*3.\*4 Update Driver/ Kernel

(1) Open the power supply, plug the U disk with upgrading programma into the USB port on the rear of the monitor;

(2) Press "MENU" rotary knob, open the main menu, enter the "system" submenu, select "Driver/Kernel";

(3) Set the parameter to "Yes", and press "MENU" rotary knob to begin upgrading;

(4) While upgrading, there will be a progress bar displaying on the screen (Note: Do not power off when upgrading);

(5) After upgraded, the monitor will automatically reboot.

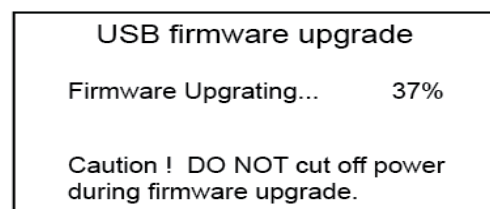

## 11. Color Measure

Color Measure	Exit	
	Log Mode* <sup>1</sup>	<u>Off</u> ,J-Log1,Log-C,S-Log2,C-Log, V-Log,RedlogFilm,User-Log
	HDR	<u>Off</u> ,PQ_709,HLG_709,S-Log3
	1DLut	<u>Default</u> ,User1,User2
	Color Measurement * <sup>2</sup>	<u>Off</u> ,On
	Import * <sup>3</sup>	<u>3DLut.cube</u> ,J-Log1.cube,Log-C.cube, S-Log2.cube,S-Log3.cube,C-Log.cube, V-Log.cube,RedLogFilm.cube, User-Log.cube,PQ_709.cube,HLG_709.cube, 1DLutUser1.csv,1DLutUser2.csv
	Reset * <sup>4</sup>	<u>3DLut.cube</u> ,J-Log1.cube,Log-C.cube, S-Log2.cube,S-Log3.cube,C-Log.cube, V-Log.cube,RedLogFilm.cube,User-Log.cube, PQ_709.cube,HLG_709.cube

### \*1 Camera Log conversion

When shooting with Log mode of the camera, you can select the corresponding Log conversion LUT, to convert the log mode video to standard ITU Rec.709 mode to monitor. A "User-Log" is provided for user defined LUT converting to Rec.709.

### \*2 HDR

CM-S73H supports three HDR modes: PQ\_709、HLG\_709、S-Log3.

### \*3 Color measurement

Set the Color measurement parameter to "On" before color calibration, make sure the parameter set to "Off" after color calibration. When reboot, the Color measurement parameter automatically set to "Off".

### \*4 Import 3DLUT cube file

(1) Use a color analysis instrument and calibration software, and set to 6500K, Gamma2.4 for color calibration, this will generate a correct cube file (recommended Konica Minolta color analyzer CA-310 and Spectracal CalMAN software);

(2) Rename the cube file to "3DLut.cube" (attention to the cap letters) , and copy to USB stick;

(3) Insert USB stick to the rear panel of the monitor. Select Operate Menu – Color Measurement – "Import" – "3DLut.cube" – "Yes" to import

(4) Import user needed Log Lut, User-log file and 1DLut by USB stick.

### \*5 Reset to factory cubes

For any wrong cubes imported that caused wrong display colors, you can reset the cubes to factory cubes here.

## 12. OSD

OSD	Exit	
	OSD Language	<u>English</u> , Chinese
	OSD Blending	<u>Low</u> , Medium, High, Off
	OSD Duration	<u>10Sec</u> , 15Sec, 30Sec, 60Sec
	OSD Zoom	Off
	Key Led Brightness	Low, <u>Medium</u> , High, Off
	Tally-R Brightness	High
	Tally-G Brightness	High
	Soft-Tally Position	Top
	Soft-Tally Blinking	On

## 13. Key Inhibit

Key Inhibit	Exit	
	Key Inhibit	<u>Off</u> , On

When the “Key inhibit” is set to “on”, there is no response when all the buttons except ” MENU” is pressed, the sreen will be displayed as ” Key Inhibit”.

User can set “Key inhibit” to off under the “Key inhibit” submenu, restore the function of all keys.

# Specification

LCD Performance		
Size	7 inch	
Display area	151.2×94.5 mm	
Resolution	1920×RGB×1200	
Color	8 bit	
Aspect ratio	16:9 / 4:3	
Brightness	3000 cd / m <sup>2</sup>	
Contrast	1200:1	
Viewing angle	Horizontal / Vertical: 160°/120°	
Input/Output		
Input	HDMI×1	HDMI input
	BNC×2	3G/HD/SD-SDI input
	USB×1	
Output	HDMI×1	HDMI output
	BNC×1	3G/HD/SD-SDI loop output
	3.5mm×1	SDI/HDMI embedded audio output
Video format		
HDMI	480i / 576i / 480p / 576p	
	1080i (60 / 59.94 / 50)	
	720p (60 / 59.94 / 50)	
	1080p (60 / 59.94 / 50 / 30 / 29.97 / 25 / 24 / 23.98)	
	1080psf (30 / 29.97 / 25 / 24 / 23.98)	
	4096X2160 (60 / 50 / 30 / 25 / 24) 3840X2160 (60 / 50 / 30 / 25 / 24)	
SDI	SMPTE-425M-A/B	1080p (60 / 59.94 / 50)
	SMPTE-274M	1080i (60 / 59.94 / 50)
		1080p (30 / 29.97 / 25 / 24 / 23.98)
	SMPTE-RP211	1080psf (30 / 29.97 / 25 / 24 / 23.98)
	SMPTE-296M	720p (60 / 59.94 / 50)
	SMPTE-125M	480i (59.94)
	ITU-R BT.656	576i (50)
SMPTE-2048-2	2048×1080p (23.98 / 24 / 25 / 29.97 / 30 / 50 / 59.94 / 60) 2048×1080i (50 / 59.94 / 60)	
General		
Input voltage	DC / Battery: 6.5V~17V	
Power consumption	≤26W	
Working temperature	-10℃~+50℃	
Working humidity	10%~90%	
Storage temperature	- 15℃~ + 60℃	
Storage humidity	10%~90%	
Dimensions	187×137×41mm	
Net weight (main body)	500 g	

# Trouble-shooting

symptom	Possible causes	Solution
No display	The power is not turned on	Please check if the power is connected, and then press "POWER" button to turn on the monitor
	Unstable power voltage	Reconnect to power supply
	BNC or HDMI cable loose contact or not correctly connected	Check and correctly connect the BNC or HDMI cable
	The attached battery is no power	Change battery
	Using DIY power supply but the polarity is reversed	Refer to the provided power supply, reconnect the power.
Image or color abnormal	Bad contact of BNC or HDMI cable	Change cable
	Video signal has Interference	Remove the interference source(s)
	Improper adjustment of the color parameters	Adjust the "Recall profile" to "Default" under "System" submenu
	Distortion of the image	Reset the Aspect ratio
	Set to Red/Green/Blue only or Mono	Turn the Blue only/ Red Only/ Green Only/Mono off under R/G/B/Mono submenu
	Turn on the "Focus Assist" function	Turn off the "Focus Assist" function
	Turn on the "False Color" function	Turn off the "False Color" function
	Signal can not correctly recognize color space, wrong set of HDMI color space.	Set to the correct color space mode
No audio output	Set to Mute	Turn off MUTE or revolve "MENU/ENTER" to adjust the volume
	Bad contact of signal cable	Connect to the correct input socket

**SWIT®**