

SONY®

Digital Video Camera

DXC-D50 Series



DXC-D50
DXC-D50P
DXC-D50WS
DXC-D50WSP



The Next-Generation DXC Camera, for High-Picture-Quality Video Acquisition

Since the first models, the Sony DXC-series of production video cameras have been widely accepted for use in a number of professional video-acquisition applications because of their superb picture quality and operational performance.

The DXC-D50/D50WS is the next-generation in the DXC-series of cameras, designed for even greater picture quality and operational convenience. These cameras are offered in two different versions: the DXC-D50 4:3 model and DXC-D50WS 16:9/4:3-switchable model. Both feature the high-performance Power HAD™ EX CCD sensor and precise 12-bit A/D conversion built into a highly sophisticated LSI.*

The result is superior picture quality, high sensitivity, plus low noise and smear characteristics over previous models.

A variety of automatic functions have also been included, allowing easy and convenient operation in any shooting scenario.

Another important aspect of Sony DXC-D50/D50WS cameras is their excellent system versatility. Two types of camera control units are available; the CCU-D50, for multi-core CCU operation, and the CCU-TX50, for Triax CCU operation. The RCP-D50/D51 Remote Controllers can also be used with either system.

With a host of sophisticated features, the DXC-D50/D50WS provides an ideal solution for small studio operations at an affordable price.

*In this brochure, the DXC-D50 refers to both DXC-D50 for NTSC and DXC-D50P for PAL, while the DXC-D50WS refers to both DXC-D50WS for NTSC and DXC-D50WSP for PAL.

FEATURES

High-Quality Pictures

Power HAD EX CCDs *fig 1*

The DXC-D50/D50WS camera is equipped with state-of-the-art three-chip 2/3-inch type Power HAD EX CCDs, offering high horizontal resolutions of 920* TV lines. A high sensitivity of F11 (at 2000 lx, 3200K), an excellent S/N ratio of 65 dB (NTSC)/63 dB (PAL), and a remarkable low smear level of -140 dB (typical) are achieved.

*On DXC-D50/D50P models

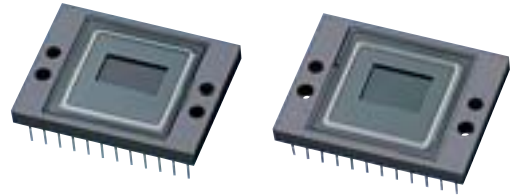

fig 1 Power HAD EX CCDs

12-bit A/D Conversion *fig 2*

The Sony DXC-D50/D50WS incorporates a high-integrity 12-bit A/D LSI, so that the high quality images captured by the Power HAD EX CCDs are processed with greater precision than conventional 10-bit A/D LSIs. In particular, this higher bit resolution allows the contrast to be reproduced more faithfully in mid-tone areas of the picture.

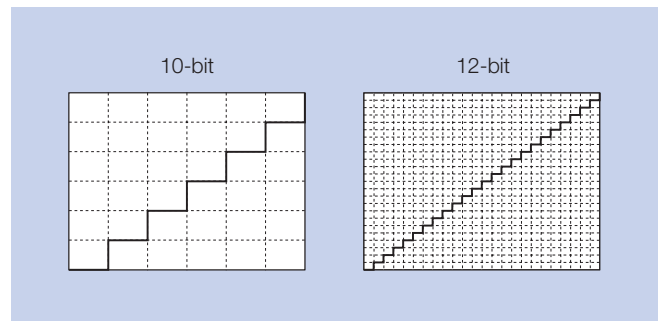

fig 2 High-Intergrity 12-bit A/D Conversion

Advanced Digital Signal Processing (DSP) *fig 3*

Another key to quality in a DSP camera is how many bits are used in its nonlinear processes, such as gamma correction.

The DXC-D50/D50WS camera uses more than 30 bits, minimizing round-off errors to maintain the CCD's high quality. The DSP LSI of the DXC-D50/D50WS also enables highly sophisticated image controls, such as Knee Saturation, and Adaptive Highlight Control functions.

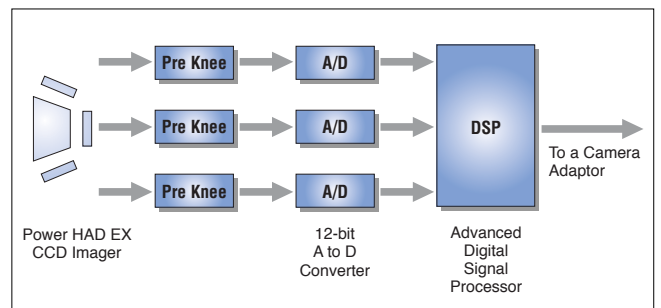

fig 3 High-Performance Digital Signal Processing

CREATIVE IMAGE CONTROL



fig 4 Knee Saturation Control Off Knee Saturation Control On

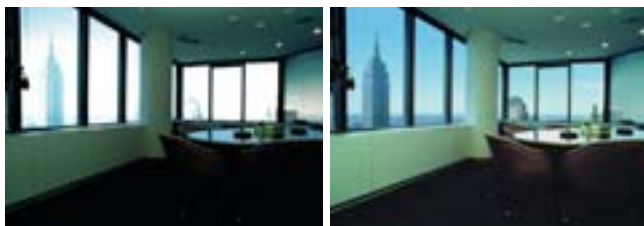

fig 5 Knee Saturation Control Off Knee Saturation Control On

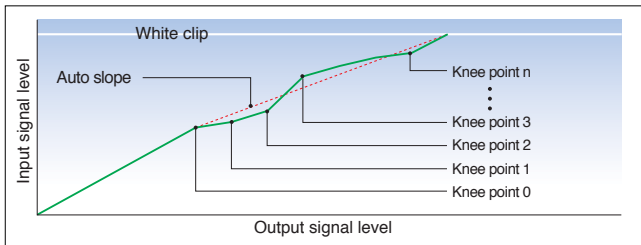

fig 5 Knee Curve Image

Natural Color Reproduction with Knee Saturation Control *fig 4*

Traditionally, shooting very bright portions of an object (such as key light reflections from a person's forehead) can reduce color saturation and change the hue in highlight areas.

The DXC-D50/D50WS cameras adopt a Knee Saturation Control function in which this 'washed-out' effect on saturation and hue change is reduced to a minimum, and far more natural color reproduction in highlight areas is achieved.

Adaptive Highlight Control *fig 5*

In conventional cameras, only a single knee-point/slope is available for contrast control over highlights. The DXC-D50/D50WS camera, however, provides multiple knee-points/slopes for superior overexposure control.

The camera analyzes the highlight areas of a scene and automatically sets and optimizes multiple knee points/slopes accordingly. This allows the reproduction of extremely difficult images (such as an interior scene that includes a brightly sunlit window) with much more overexposure latitude. This function applies only to input video levels in excess of the knee point - the middle and low luminance parts of the video signal are unaffected by this control.

Low Key Saturation *fig 6*

With traditional cameras, low-light areas can be subject to reduced saturation, resulting in the color in these areas being "washed-out". The Low Key Saturation function on the DXC-D50 series helps eliminate this problem by optimizing the amplification of color saturation at low light levels, providing more natural color reproduction.



fig 6 Low Key Saturation Off

Low Key Saturation On

Cross-Color Suppression *fig 7*

Separating the luminance and chrominance components of a composite signal can be a difficult task, even with the most advanced comb-filtering techniques. In order to keep cross color and cross luminance to a minimum, the DXC-D50 series virtually eliminates frequency components that may result in such artifact being generated prior to the signal output. These frequency components are virtually eliminated from the Y/R-Y/B-Y signals within the camera head through sophisticated digital three-line (NTSC)/five-line (PAL) comb filtering, resulting in a great reduction of the cross color and dot crawl normally seen on picture monitors fed with a composite video signal.

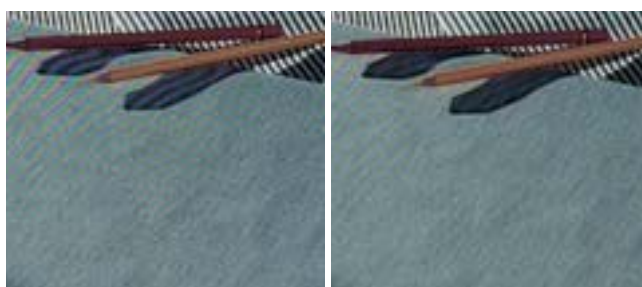

fig 7 Cross Color Suppression Off

Cross Color Suppression On

Skin-Tone Detail Control *fig 8*

The Skin-Tone Detail function on the DXC-D50/D50WS allows softer detail correction to be applied in the facial area, while maintaining the sharpness of other parts of the picture.

The Skin-Tone Detail area can be selected simply and quickly using the Area-Detect Cursor in the viewfinder screen. The color range for the Skin-Tone Detail (and skin detail level) can also be selected manually using the viewfinder menu system.



fig 8 Skin-Tone Detail Control Off

Skin-Tone Detail Control On

OPERATING CONVENIENCE

EZ Functions

Recognizing the importance of making camera operation as quick and straightforward as possible, the DXC-D50/D50WS camera provides two highly convenient "EZ Functions", enabling operators to start shooting with minimum setup procedures, and in less time.

EZ Mode

Settings for key camera parameters are instantly set to the standard or auto position by simply pressing the EZ Mode button - making the camera instantly ready for shooting. This feature is very convenient when operators require fast camera setup within a limited time frame.

EZ Focus

The EZ Focus function allows accurate focus adjustments without manually opening the lens iris. Simply by pushing the EZ Focus button, the iris automatically opens to reduce the depth of field and make focusing significantly easier. At the same time, the electronic shutter is automatically set to obtain the correct exposure.

Supplied DXF-801 Viewfinder

The DXC-D50/D50WS is equipped with a 1.5-inch* type Black and White viewfinder, which includes the following features.



VF Light

- Automatic scan-size switching between 16:9 and 4:3
- VF light (LED)
- Time, camera ID, and color temperature display
- Display switch - turns off character superimposition on the viewfinder
- Vertical and horizontal detail-level control via peaking potentiometer
- Tally lamp levels (high/low/off)
- Two red REC tally lamps
- Diecast aluminum body
- Wide range of diopter adjustments

*Viewable area measured diagonally.



Optical ND Filter and Electronic CC Filter

Using the DXC-D50/D50WS, optimum light and color control is easily achieved using an optical ND (Neutral Density) filter wheel and electronic Color Correction. The use of electronic Color Correction allows all filters in the filter wheel to be of the ND type, providing the operator with greater flexibility in depth-of-field and exposure control. Electronic Color Correction can also be controlled using a remote controller, for even easier operation.

Auto-Tracing White Balance (ATW)

The DXC-D50/D50WS camera features a convenient Auto-Tracing White Balance (ATW) function, which automatically adjusts white balance as lighting conditions change. This function is very useful when shooting in rapidly changing lighting conditions, such as when moving from indoor to outdoor locations.

Backlit Switch Panel

The switch panel is backlit, allowing operators to see switch positions in dark environments.

File Operation Using "Memory Stick"™ Media Storage

The DXC-D50/D50WS incorporates the Sony Memory Stick system, enabling you to store and recall setup-parameter files for individual scene or camera setup preferences. The setup parameter files stored on a Memory Stick media card can be transferred to another DXC-D50/D50WS camera or a RCP-D50/D51 remote control unit, allowing quick, easy setup in multiple camera systems. What's more, the setup files can be loaded to a PC equipped with a Memory Stick slot, enabling them to be e-mailed as attachments and share them with cameras at remote locations.



Clear Scan™ (CLS) Function

The Clear Scan function allows operators to shoot computer displays without the horizontal bands or flickers they usually create on screen. This is achieved by activating the Clear Scan function to select a shutter speed, which then precisely matches the scanning frequency of the computer display. Shutter speeds are available ranging from 60.1 (NTSC)/50.2 (PAL) Hz to 6000 Hz.

Factory-Preset Matrix

Factory-Preset Matrix files are provided, allowing operators to instantly set up camera parameters that match common lighting situations, such as STANDARD, HIGH SATURATION, FLORESCENT, etc.

Adjustable Shoulder Pad

The position of the shoulder pad can be adjusted - either forwards and backwards - to provide the operator with a comfortable, well-balanced camera, both when docked with a camera adaptor or with a dockable VTR.



Other Features

- Programmable gain (-3/0/3/6/9/12/18/24/30/36 dB)
- Variable-speed electronic shutter
- Monitor output
- Built-in 1 kHz audio reference
- Date-and-time superimposition on the video signal and viewfinder
- Enhanced Vertical-Definition System (EVS)
- Auto iris mode (spot, backlight)
- Mic low cut
- Dual zebra

SYSTEM VERSATILITY

The DXC-D50/D50WS can be used with a variety of peripheral equipment including camera adaptors, camera control units, dockable VTRs and remote controllers, allowing operators to flexibly build systems according to their needs both in the studio and out in the field. The DXC-D50/D50WS can be configured in four core operation styles: Multicore CCU, Triax CCU, camcorder, and portable-VTR operation.

An easy-to-use range of remote controllers - the RCP series - is also available for added operational convenience.



Multi-Core CCU Operation - for End-to-End Digital Systems CCU-D50 and CA-D50

With the CA-D50 Camera Adaptor attached, the DXC-D50/D50WS can be remotely controlled from the CCU-D50/D50P Multicore Camera Control Unit using a CCZ-A cable (26-pin).

The video and audio output of the CA-D50 Camera Adaptor are transferred to the CCU-D50/D50P Camera Control Unit as a component digital-SDI signal*¹ through a CCZ-A cable up to 75 m long. This combination allows to the establishment of a full digital-acquisition system.

The CCU-D50/D50P system supports the following features:

- Digital or analog signal transmission (switchable)
- 75 m cable compensation for component digital-SDI transmission via a CCZ-A cable (26-pin)

- 200 m cable compensation for component digital-SDI transmission using a separate low-loss coaxial video cable in addition to a CCZ cable
- Analog transmission for longer control distances of up to 300 m via a CCZ-A cable
- Analog composite output and one of the following outputs:
SDI, Y/R-Y/B-Y, RGB, Y/C
- Wide variety of control functions
- Compatibility with remote-control panels, including the RCP-D50, RCP-D51 and RM-M7G
- Support for major intercom systems (two-wire/four-wire/RTS/Clearcom)
- Teleprompter support
- Red/Green tally indication*²
- Fan alarm LED*²

*¹ Embedded audio is not supported.

*² The tally and fan alarm share the same LED.



CCU-D50 Front Panel



CCU-D50 Rear Panel



Triax CCU Operation
- for Wide-Bandwidth Transmission
CCU-TX50 and CA-TX50

With the CA-TX50/TX50P Triax Camera Adaptor attached, the DXC-D50/D50WS can be remotely controlled from the CCU-TX50/TX50P Camera Control Unit using a Triax cable, the use of which enables sophisticated remote control over extended operating distances. The wide-bandwidth transmission system is employed, enabling the higher resolution of DXC-D50/D50WS camera to be transmitted with virtually no drop in resolution.

The CCU-TX50/TX50P supports the following features:

- Wideband transmission
(10 MHz for Y and 4.5 MHz for R-Y/B-Y)
- High-quality analog component video transmission
- Long-distance transmission
(ex. 1500 m via a ø 14.5 mm cable)
- Compact design - half rack width and 3U height
- Wide range of advanced control functions
- Compatibility with the RCP-D50 and RCP-D51 Remote Control Panels
- Three SDI outputs or three composite outputs
- One component output (Y/R-Y/B-Y or R/G/B selectable)
- Three inputs for return video (BNC type)
- Teleprompter support
- Red/Green tally indication
- Support for major intercom systems
(four-wire/RTS/Clearcom)
- Program audio input
- Two-channel microphone system
(two XLR connectors)



CCU-TX50 Front Panel

Camcorder Operation



DSR-1 (DVCAM™ VTR)

The DSR-1/1P is a dockable recorder that allows 4:1:1 (NTSC)/4:2:0 (PAL), 8-bit DVCAM digital recordings. This configuration provides a long recording time and supports both DVCAM Mini and Standard cassette types.

- Compact and lightweight: 3.1 kg (6 lb 13 oz) including battery
- Support for both Mini and Standard cassettes
- Superb picture quality of the DVCAM format
- Playback capability of DV-recorded tapes (SP mode only)
- Long recording time of 184 (Standard cassette)/40 (Mini cassette) minutes



PVV-3 (Betacam SPT™ VTR)

By combining the DXC-D50/D50WS with the PVV-3/3P Betacam SP recorder, you can easily configure a Betacam SP camcorder system.

- Compact and lightweight: 3.5 kg (7 lb 11 oz) including battery
- Superb picture quality of the Betacam SP format
- More than 30 minutes recording time



CCU-TX50 Rear Panel

Remote Controllers

For remote operation of the DXC-D50 camera, three types of remote controllers are available, each offering direct control of the DXC-D50/D50WS camera.

RCP-D50 (Joystick Type)

RCP-D51(Dial Type)

The RCP-D50 and RCP-D51 have been designed for use with Sony DXC-D50/D50WS cameras. The RCP-D50 is a joystick-type controller, while the RCP-D51 is a dial-type controller. Both are equipped with a 3.5-inch* color touch panel LCD screen and offer extensive control of camera functions through easy-to-use menu-based operations. The LCD also allows the incoming camera image to be monitored - a feature that comes in handy when identifying which RCP is controlling which camera in multi-camera systems.

Another convenient feature is the Memory Stick system, which allows various scene files to be stored on and recalled from the Memory Stick media and loaded to either a different RCP-D50/D51 controller, or to a DXC-D50 camera.

*Viewable area measured diagonally.

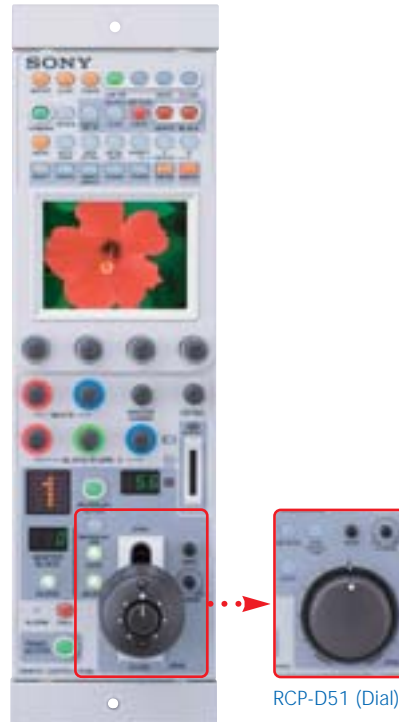

RCP-D50 (Joystick)

RCP-D51 (Dial)

RM-M7G

The RM-M7G controller is a compact, handheld-type remote controller ideal for use in the field, or for basic remote control.

*Cannot be used with CCU-TX7/TX7P.



RM-M7G

OPTIONAL ACCESSORIES



DSR-1/1P
DVCAM Digital Recorder
(photo shows DSR-1 with
BP-L40A)



PVV-3/3P
Betacam SP 2000 PRO Recorder



CA-D50
Camera Adaptor



CA-TX50/TX50P
Camera Adaptor



CCU-D50/D50P
Camera Control Unit



CCU-TX50/TX50P
Camera Control Unit



RCP-D50
Remote Control Panel



RCP-D51
Remote Control Panel



RM-M7G
Remote Control Unit



BP-GL95/GL65/L60S
Rechargeable Li-ion Battery Pack



BC-M150
Battery Charger for
BP-GL95/GL65/L60S



BC-M50
Battery Charger for
BP-GL95/GL65/L60S



AC-DN10
AC Adaptor



ECM-672/670
Electret Condenser Microphone
(photo shows ECM-672)



CAC-12
Microphone Holder



WRT-847A/847B*1
UHF Synthesized Transmitter



WRT-822A/822B
UHF Synthesized Transmitter



WRR-861A/861B*2
UHF Synthesized Tuner



WRR-862A/862B*2
UHF Synthesized Tuner



DXF-51
5-inch Monochrome Viewfinder



VCT-U14
Tripod Adaptor



CCZ-A5/A10/A25/A50/A100
Connecting Cable (26-pin - 26-pin)



LC-421
Hard Carrying Case



LCR-1
Rain Cover

Lenses



A13 x 6.3 BERM/BRM
(Fujinon)



A20 x 8.6 BERM/BRM
(Fujinon)



YJ12 x 6.5 IRS/KRS
(Canon)



YJ19 x 9B IRS/KRS
(Canon)

*1 Microphone capsule is optional.

*2 When a lithium-ion battery (BP-GL95/GL65/L60S) is mounted on a DSR-1/1P or PVV-3/3P, a mounting bracket (A-8278-057-A) is required.

PRODUCT CONFIGURATION

	DXC-D50K/D50PK	DXC-D50L/D50PL DXC-D50WSL/D50WSPL	DXC-D50H/D50PH
Camera Head	Yes	Yes	Yes
Camera Handle	Yes	Yes	Yes
DXF-801 Viewfinder (includes microphone holder)	Yes	Yes	Option
VCT-U14 Tripod Adaptor	Yes	Yes	Option
External Microphone	Yes	Yes	Option
Zoom Lens	Yes	Option	Option

SYSTEM CONFIGURATION

ECM-670/ECM-672
(External Mic.)



DXF-51
(Large Viewfinder)

CAC-12
(Mic. Holder)

Mic. Cable

DXC-D50/D50P or
DXC-D50WS/D50WSP
(Camera Head)

Zoom Lens

VCT-U14
(Tripod Adaptor)

CCA-7

RM-M7G
(Remote Controller)

RCP-D50/D51
(Remote Control Panel)

LC-421
(Carrying Case)

LCR-1
(Rain Cover)

Use as a portable camera

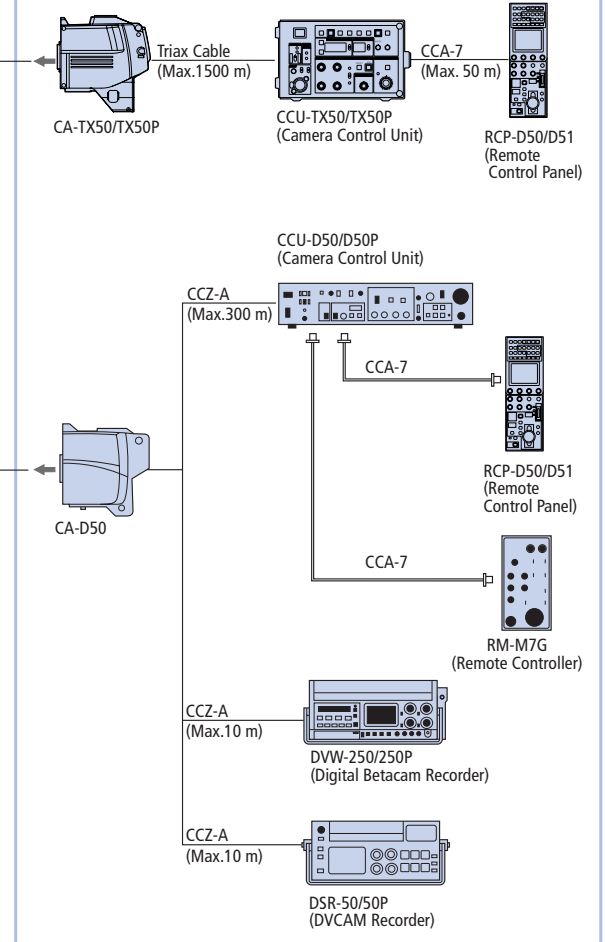

Camcorder operation

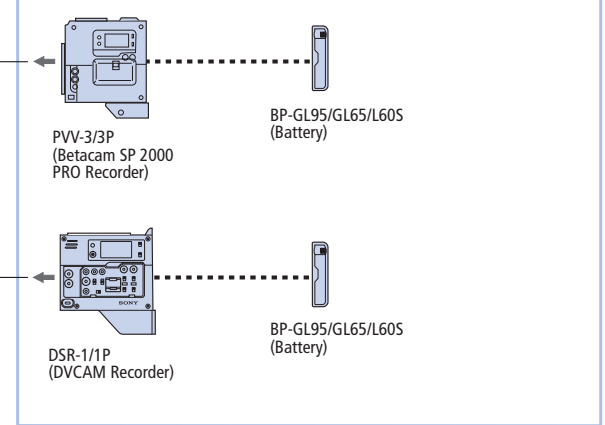

*The RCP-D50/D51 and RM-M7G cannot be used together.

SPECIFICATIONS

	DXC-D50	DXC-D50P	DXC-D50WS	DXC-D50WSP
General				
Power requirements	DC 12 V (10.5 to 17 V)			
Power consumption	14 W			
Operating temperature	-10 °C to 45 °C (14 °F to 113 °F)			
Storage temperature	-20 °C to 60 °C (-4 °F to 140 °F)			
Operating humidity	Less than 85%			
Mass (camera head only)	2.2 kg (4 lb 13 oz)			
Dimensions (W x H x D)	126 x 258 x 265 mm (5 x 10 1/4 x 10 5/8 inches), camera head only			
Signal inputs/outputs				
Video output	Analog composite	BNC, 1.0 Vp-p, sync negative		
Monitor output	Analog composite	BNC, 1.0 Vp-p, sync negative		
Microphone input	XLR-3-pin			
Other inputs/outputs				
Camera/VTR interface	Pro 76-pin Digital, Pro 50-pin			
Lens	12-pin			
VF	20-pin			
Remote	10-pin			
Camera performance				
Pickup device	3-chip 2/3-inch, Power HAD EX CCD			
Aspect ratio	4:3			16:9/4:3 switchable
Total picture elements (H x V)	1038 x 1008	1038 x 1188	1038 x 1008	1038 x 1188
Effective picture elements (H x V)	980 x 494	980 x 586	980 x 494	980 x 586
Optical system	F1.4 medium index prism system			
Built-in filters	1: Clear, 2: 1/4ND, 3: 1/16ND, 4: 1/64ND			
Lens mount	Sony 2/3-inch Bayonet mount			
Signal system	NTSC color system	PAL color system	NTSC color system	PAL color system
Scan format	2:1 interlaced, 525 lines, 60 fields/s	2:1 interlaced, 625 lines, 50 fields/s	2:1 interlaced, 525 lines, 60 fields/s	2:1 interlaced, 625 lines, 50 fields/s
Horizontal scan frequency 15.734 kHz	15.625 Hz	15.734 kHz	15.625 Hz	
Vertical scan frequency	59.94 Hz	50 Hz	59.94 Hz	50 Hz
Sync system	Internal and External with the VBS or BS signal			
A/D conversion	12 bits			
Sensitivity	F11 at 2000 lx (3200 K, 89.9% reflectance) (typical)			
Minimum illumination	0.5 lx with F1.4, Hyper gain (36 dB), 0.8 lx with F1.8, Hyper gain (36 dB)			
Video S/N ratio (typical)	65 dB	63 dB	65 dB	63 dB
Horizontal resolution	920 TV lines		850 TV lines (4:3 mode),	800 TV lines (16:9 mode)
Vertical resolution	400 TV lines (without EVS) 450 TV lines (with EVS)	480 TV lines (without EVS) 530 TV lines (with EVS)	400 TV lines (without EVS) 450 TV lines (with EVS)	480 TV lines (without EVS) 530 TV lines (with EVS)
Shutter speed	OFF, 1/100, 1/250, 1/500, 1/1000, 1/2000 s	OFF, 1/60, 1/250, 1/500, 1/1000, 1/2000 s	OFF, 1/100, 1/250, 1/500, 1/1000, 1/2000 s	OFF, 1/60, 1/250, 1/500, 1/1000, 1/2000 s
Clear scan	60.1 to 6000 Hz			
Gain selection	-3, 0, 3, 6, 9, 12, 18, 24, 30, 36 dB			
Registration	0.05% (all zones, without lens)			
Geometric distortion	Below measurable level			
Viewfinder: DXF-801 (supplied with DXC-D50K/D50PK/D50L/D50PL/D50WSL/D50WSPL package)				
CRT	1.5-inch monochrome, 4:3/16:9 switchable			
Indicators	REC TALLY (2), TAKE TALLY, BATT, SHUTTER, GAIN UP			
Horizontal resolution	600 TV lines			
Power requirements	DC 12 V			
Power consumption	2.1 W			
Mass	620 g (1 lb 9 oz)			
Dimensions (W x H x D)	240 x 91 x 196 mm (9 1/2 x 3 5/8 x 7 3/4 inches) including protruding parts projection			

DIMENSIONS

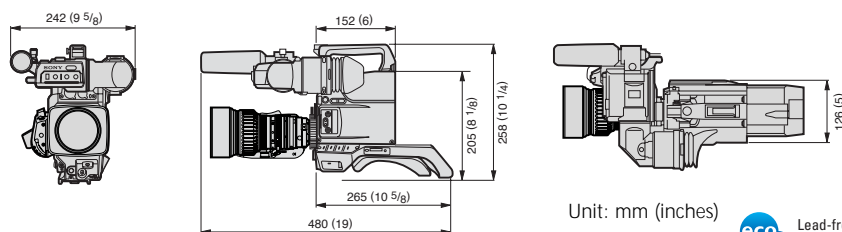

Lead-free solder is used for soldering.

Halogenated flame retardants are not used in the cabinets and the printed wiring boards.

Distributed by

©2004 Sony Corporation. All rights reserved.
 Reproduction in whole or in part without written permission is prohibited.
 Designs, features, and specifications are subject to change without notice.
 All non-metric weights and measures are approximate.
 Some images in this brochure are simulated.
 Sony, Betacam SP, Clear Scan, DVCAM, Memory Stick and Power HAD are trademarks of Sony Corporation.