

datavideo

Product Guide
2016
2017



Vision Mixers | Video Recorders | Chromakey | Virtual Studio |
PTZ Cameras | Monitors | Studio Equipment | Streaming Solutions |

CONTENTS

Mobile Rack Systems 4	Converters 52	Teleprompters 62	Power Centers 70
OBV-2800-CCU	DAC-70	TP-150	PD-2A
CCU-100P/ S/ J	DAC-60	TP-300	PD-4A
CR-43/44/45/49	DAC-50S	TP-500	PD-6
MS-2800	DAC-9P	TP-600	
Portable Video Studios 15	DAC-8P	HC-500/ 600	DC to DC Converter 70
HS-2850	DAC-7	DVP-100	DDC-4012H
HS-2800			Audio Converters 71
HS-2200	Accessories 53	Video Streaming Server 64	DAC-90
HS-1500T	RMK-2	NVS-25	DAC-91
HS-1200	MB-4/ 5/ 6	DV Streaming Server 65	DAC-80
Digital Video Switchers 27	Digital Video Recorders 54	DVS-100P	BAC-03
SE-2850	HRS-30	IP Video Decoders 65	Cables 72
SE-2800	HDR-60	NVD-20/ 25	CB-60/ 61/ 62
SE-2200	HDR-70	Network Media Player 65	CB-46/ 47/ 50
SE-1200 (SE-1200MU+RMC-260)	HDR-10	NVP-20	CB-30/ 31
SE-700	RMC-400	Intercom/Tally Systems 66	CB-22H/ 23H
SE-650		ITC-100	Distribution Amplifiers 74
SE-500HD	Character Generators 56	ITC-100SL	VP-597
SE-600	TC-200+CG-200	HP-1/ 2A	VP-445
SE-500	CG-500	Chromakey 67	Repeaters 74
4K Multi-Channel Unit 46	CG-350	DVK-300HD	VP-781
KMU-100	CG-250	Accessories 67	VP-737
Video Commanders 48	PTZ Cameras 58	MAT-2/ 5	VP-634/ 633
MTX-100/ 200	PTC-150T/ PTC-150TW	TA-1/ 2	VP-605H
Video Monitors 50	PTC-150/ PTC-150W	PLK-300	Virtual Studio Systems 76
TLM-170P/ PM/ PR	RMC-180	PLK-400	TVS-1000/ 1200
TLM-170G/ GM/ GR	HDBaseT Receiver/ Transmitter Box 60		RMC-220
TLM-702HD	HBT-11	Test & Measurement 68	TVS-AUX
TLM-700HD	HBT-10	VS-100	Virtual Interactive Board Systems 79
TLM-434H	Camera Controllers 61	VS-150	VGB-1000F/ R
TLM-430	MCU-100P/ S/ J	VSM-100	LBK-1
	MCU-200P/ S/ J	VSM-200	MS-VGB1K
	AD-1P/ S/ J	Audio Delay/ Audio Mixers 69	IEPEN
	RMC-230	AD-200	FS-210
		AD-100M	



OBV-2800CCU



MRS-2800



MS-2800A/B/C/D



HS-2850



HS-2800



HS-2200



HS-1500T



HS-1200

Mobile Rack Systems



OBV-2800-CCU



MRS-2800



MS-2800



HD/SD 12-Channel Mobile Video Studio
OBV-2800CCU

OBV-2800
 Product Video



Datavideo OBV-2800-CCU is a PPU (Portable Production Unit), designed to fit into the back of a small van to provide complete mobile production facilities. It's a transportable

solution for broadcasters and professionals for both in-studio and on-location productions.



Built around the latest HD/SD switcher, it supports up-to 12 channels of HD/SD-SDI, HDMI or composite video signals. The system is integrated, compact, and sturdy with a metal framework for great stability and protection yet provides room for future expansion.

With power-efficient modules, OBV-2800-CCU can be powered by a DC 12V supply. Datavideo OBV-2800 is easy to install and a cost-effective solution for live video production.

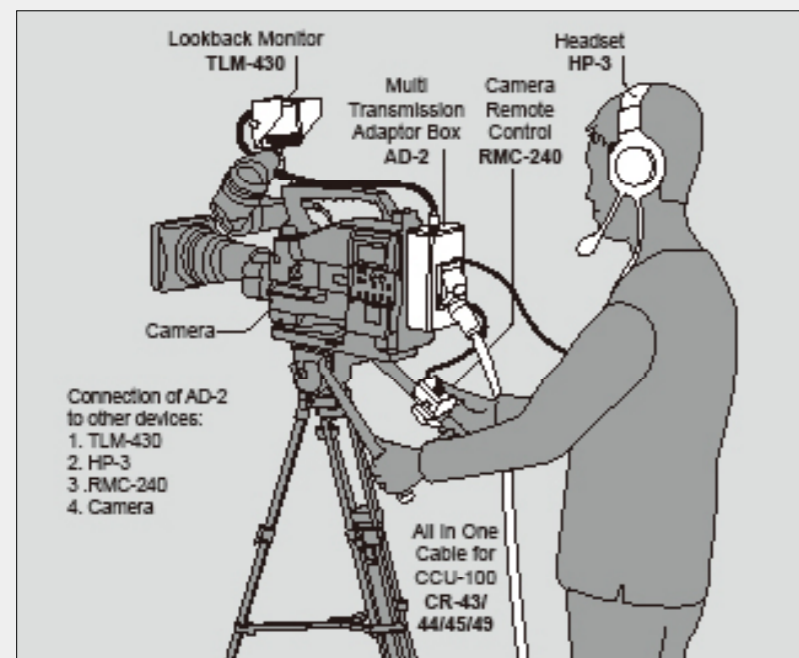
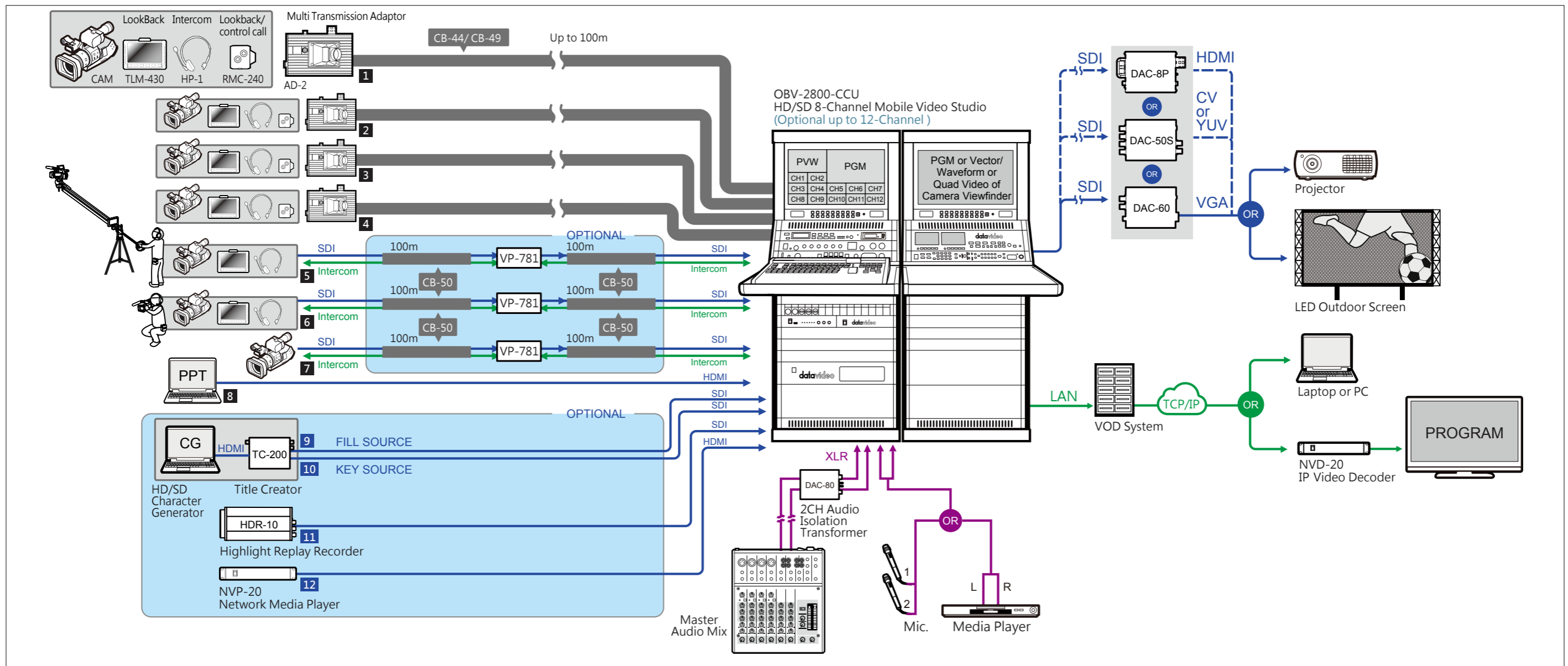

OBV-2800CCU is compact but fully equipped with functions such as intercom, video transmission, camera control, video recording, etc. Datavideo offers a complete product line for all broadcast tasks. The most unique part of the OBV-2800-CCU design is the AD-2 Camera CCU adaptor, which is connected to OBV-2800-CCU using proprietary CR-43/44/45/49 all-in-one cable to eliminate the hassles of complex long cable connection.

AD-2 Camera CCU Adaptor uses CR-43/44/45/49 CCU proprietary all-in-one cable to connect to the rear panel of the CCU-100 four-camera control center.



AD-2 is attached to the rear of the camera directly. The multi-function CB cable plugs directly into the AD-2.

CR-43/44/45/49 is connected to the CCU-100 Four-Camera Control Center on the rack.

AD-2 can be connected to the camera using short cables without having to worry about tangled cabling.

Camera Control Unit CCU-100



The CCU-100 camera control unit packs multiple signals into one cable. Camera power, camera signal, camera control, intercom and lookback are all carried by a single cable.

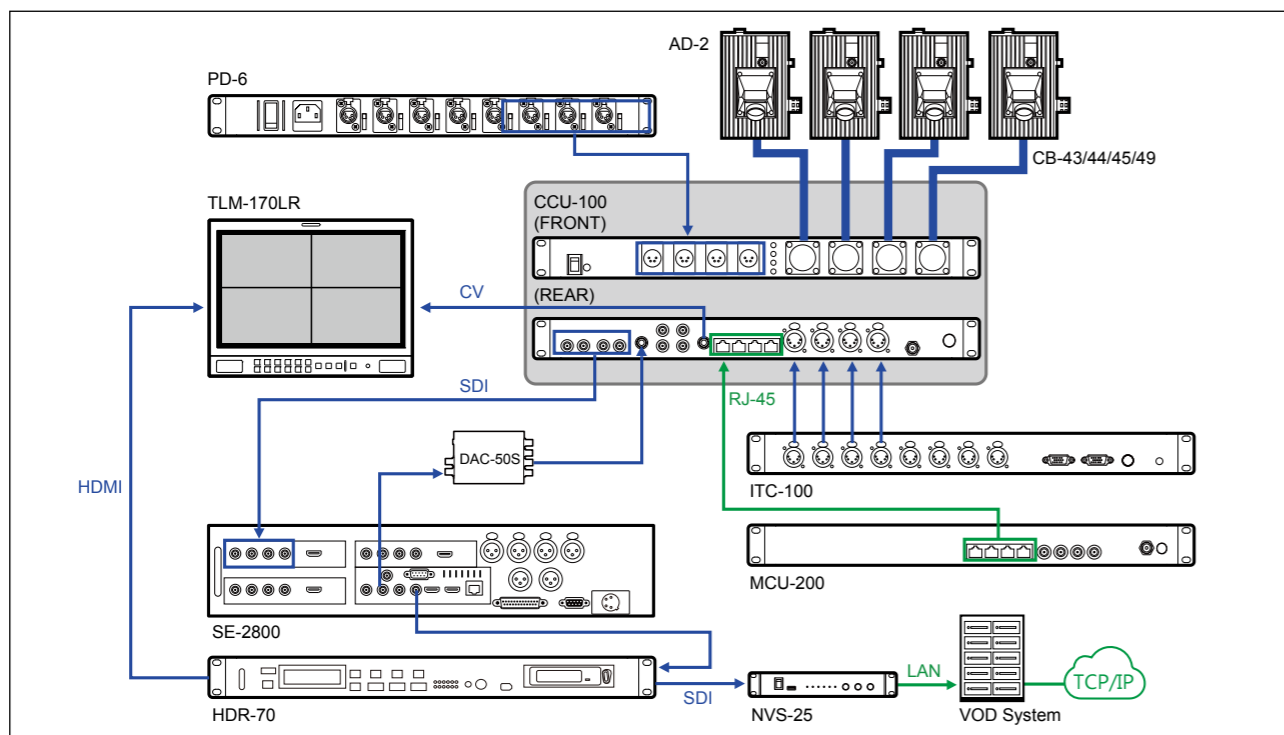

Multi Transmission Adaptor Box AD-2P/2S/2J



The camera control system CCU-100, AD-2 and CR-43/44/45/49 provide a robust 30-100m all-in-one cable link between a professional camera and a digital video switcher system. The system simultaneously transports digital SDI and analog signals as well as camera control, look back, camera data, tally and intercom call signals between the camera and switcher system.

All in One Cable for CCU-100 CR-43/44/45/49



Datavideo offers the user four choices of CCU proprietary cable: 30m, 50m, 80m and 100m.

- CB-43:30m
- CB-44:50m
- CB-45:80m
- CB-49:100m



CB-43/44/45/49



CR-1



Camera Control Systems

The most unique part of the OBV-2800-CCU design is the AD-2 Camera adaptor, which is connected to OBV-2800-CCU using the proprietary CR-43/44/45/49 all-in-one cable in order to eliminate the hassles of complex long cable connection.



All in one cable for CCU-100
CR-43/44/45/49

AD-2 series			OBV-2800-CCU				
Intercom System	Composite Look Back Video	SDI Video	SE-2800 HD/SD 12-Channel Digital Video	TLM-170GR 17.3" HD/SD TFT LCD Monitor	AD-200 Audio Delay Box with Level Adjustment	MCU-200 Multi-camera Control Unit	CCU-100 Camera Control Unit
Camera Control	Camera Power Supply	Viewfinder Video	PD-6 Camera Power Center	TLM-170GR 17.3" HD/SD TFT LCD Monitor (Look Back Quad Split Multiviewer)	HDR-70 HD/SD Digital Video Recorder	VSM-100 Sampling Vector Scope Monitor	PD-2A AC Power Distributor

Sled SLD-1(optional)

With Datavideo's SLD-1, you can mount your camcorder and Datavideo's Multi Transmission Adaptor AD-2.



HD/SD 12-Channel Mobile Video Studio
MS-2800

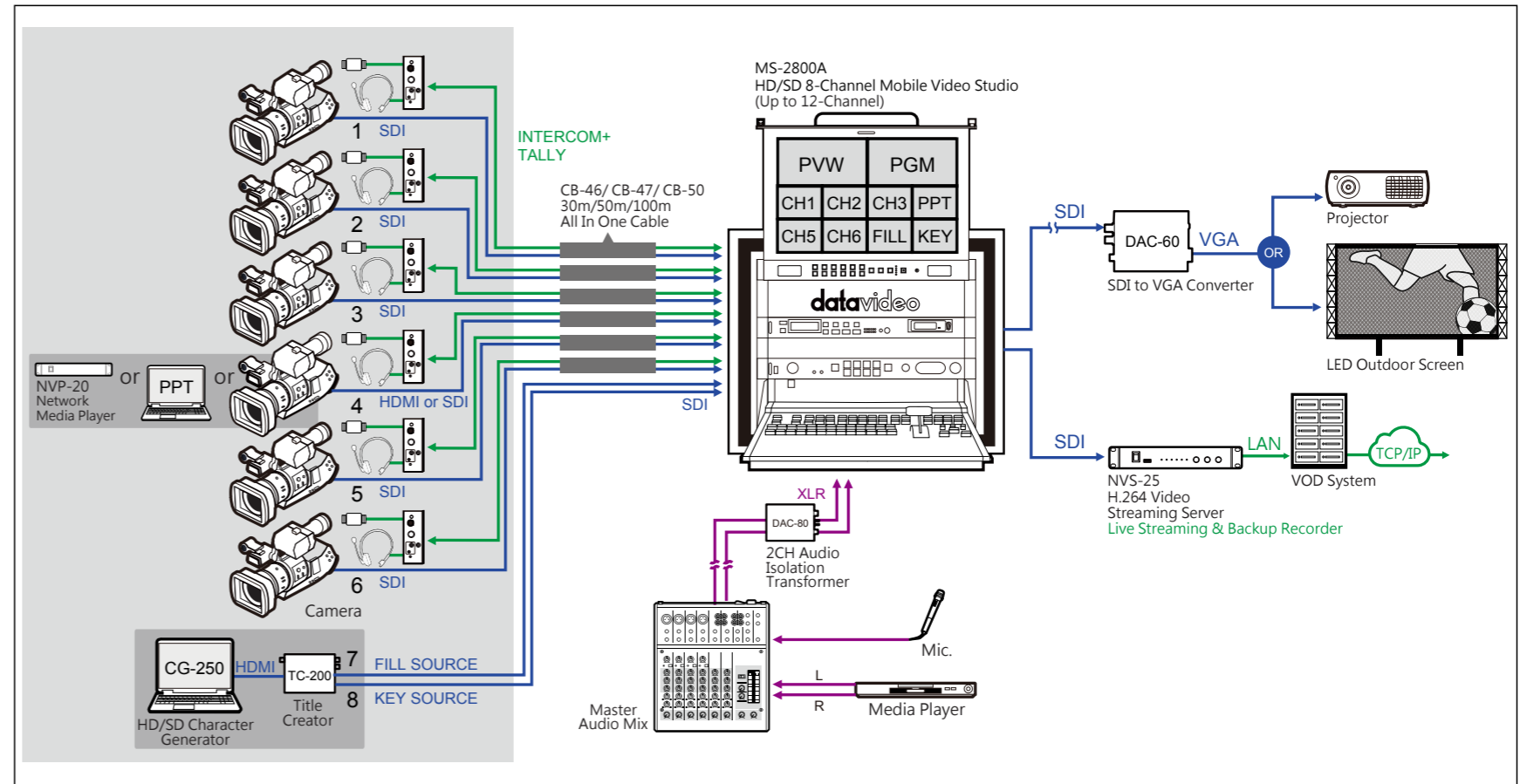



Live in seconds!

Datavideo MS-2800 HD/SD mobile video studio is a ready to go solution. It is designed around the SE-2800 HD/SD 8-channel (upgradeable to 12 channels) broadcast-quality video switcher. It is perfect for outdoor events, conferences, education, places of worship and many more applications. Producing superb quality pictures with versatile input/output configurations, the SE-2800 also has powerful, easy to use effects, such as dual picture in picture, downstream keyer (DSK) and logo insertion.

The switcher is integrated with the essential elements required for live production including a player/recorder, multi-view monitor and intercom system.



Portable Video Studios

Model	OBV-2800-CCU	MRS-2800	MS-2800
			
Description	OBV Rack System with CCU 8/12-CH HD/SD-SDI inputs 27RU Mobile Rack System (x2)	Mobile Rack System 8/12-CH HD/SD-SDI inputs 27RU Mobile Rack System	Mobile Video Studio 8/12-CH HD/SD-SDI inputs 8RU Flight Case
Configuration			
Digital Video Switcher	SE-2800-8/12	SE-2800-8/12	SE-2800-8/12
17.3" Rack Mount LCD	TLM-170GR x2	TLM-170GR x1	TLM-170GM x1
HD/SD SDI Recorder	HDR-70 x1	HDR-70 x1	HDR-70 x1
Intercom/Tally system	ITC-100 w/4 Belt Pack	ITC-100 w/4 Belt Pack	ITC-100 w/4 Belt pack
SDI Vector Scope	VSM-100	---	VSM-100(MS-2800B/D)
Audio Delay Mixer	AD-200	AD-200	AD-100M (MS-2800A/ B) AD-200 (MS-2800C/ D)
Power distributor (8-way)	PD-2A	PD-2A	PD-2A
Return Video (8-CH CV)	---	---	RP-64
Camera Control System	CCU-100+AD-2+CB-45	---	---
Multi-Camera System	MCU-200	MCU-200	MCU-200
Camera Power Distributor	PD-6	---	PD-6 (MS-2800 B/D)
H.264 Video Streaming Server	NVS-25	---	---
HD/SD SDI Amplifier	VP-445 x1	VP-445 x1	VP-445 x1(MS-2800B/D)
Rack System Integration	27RU Mobile Rack System x 2	27RU Mobile Rack System x 1	8RU Flight Case
Weight	85KG	42KG	65KG
Options			
SDI Vector Scope	---	VSM-100	VSM-100 (MS-2800A/ C)
Return Video (8-CH CV)	---	RP-64	RP-64(MS-2800A/C)
Camera Power Distributor	---	PD-6	PD-6 (MS-2800A/ C)
Camera Power Regulator	DDC-4012H (9-30V to DC12V)	DDC-4012H (9-30V to DC12V)	DDC-4012H (9-30V to DC12V)
Redundant Power (360W)	PD-4A	PD-4A	PD-4A(MS-2800A/C)
Return Video LCD (CV)	TLM-430 with Ball head	TLM-430 with Ball head	TLM-430H with Ball head
SDI/CV/ITC/DC cable	CB-22H/CB-23H (30m/50m)	CB-22H/CB-23H (30m/50m)	CB-22H/ CB-23H(30m/ 50m)
CB-22H/23H Repeater	VP-605H	VP-605H	VP-605H
SDI/CV/ITC/Cat-5 cable	CB-30/31 (30/50m)	CB-30/31 (30/50m)	CB-30/31 (30/50m)
SDI/ITC cable	CB-46/47/50 (30/50/100m)	CB-46/47/50 (30/50/100m)	CB-46/47/50 (30/50/100m)
ITC/Tally cable	CB-3/CB-4 (20m/50m)	CB-3/CB-4 (20m/50m)	CB-3/CB-4 (20m/50m)
100m SDI Repeater	VP-633/VP-634	VP-633/VP-634	VP-633/VP-634
Distribution Amplifier	---	---	VP-445 (MS-2800B/ D)

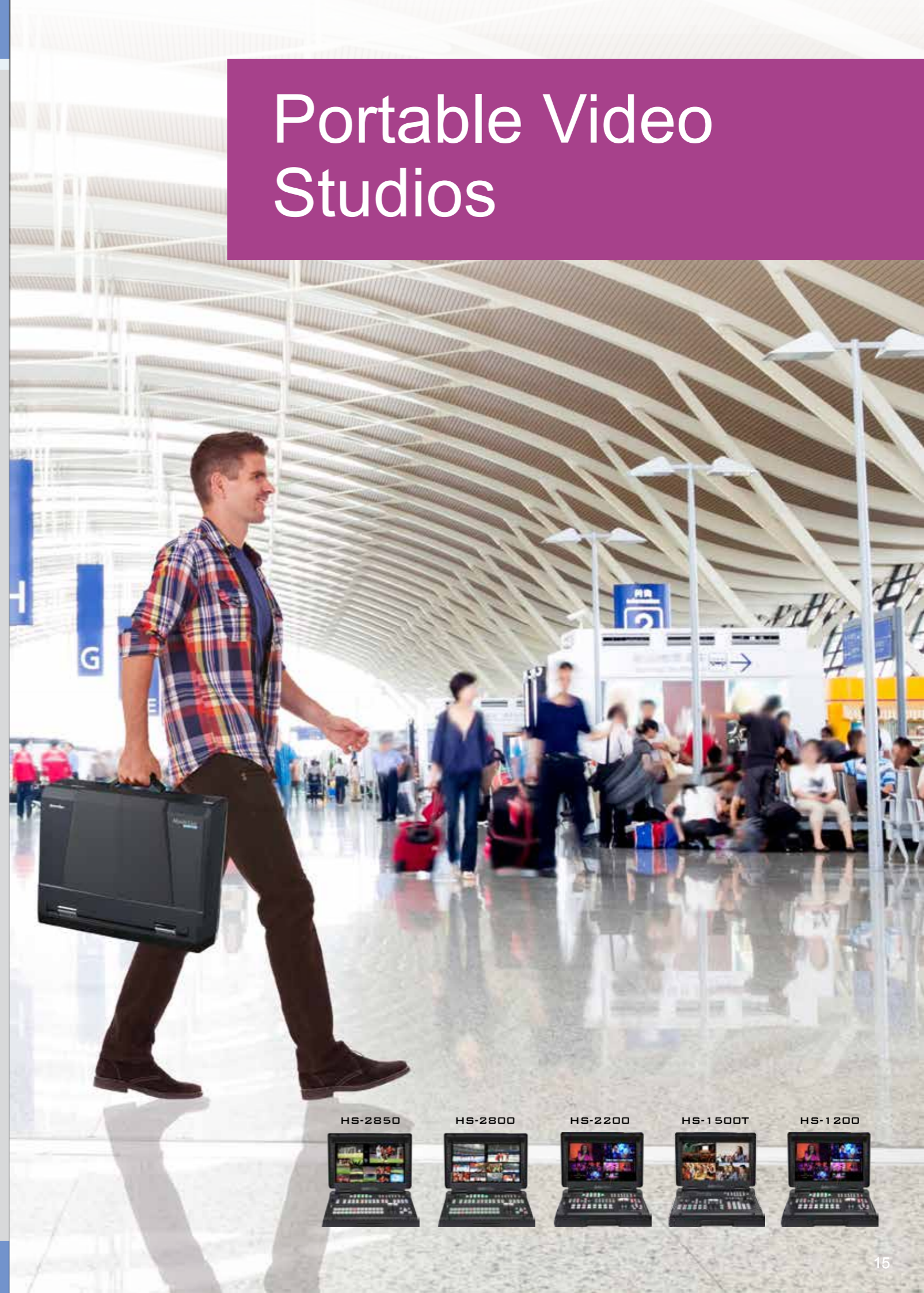

HD/SD 12-Channel Portable Video Studio
HS-2850



Re-defining mobile production

HS-2850 is a 12 channel 10-bit broadcast-quality hand carry mobile switcher, which supports 1080p resolution video. Featuring 12 digital inputs, it is designed for live events and TV programs that need to mix a variety of video and audio sources.

The HS-2850 is a lightweight, portable and powerfully featured mobile studio solution.

As a complete AV package, the HS-2850 mobile studio enables users to switch seamlessly between video and audio

sources and blend high-quality digital content on the fly. Advanced features include an integrated 17.3-inch video monitor, which displays the multi-view. The multi-view includes all the input sources, as well as preview and program. The built-in title creator works with a laptop to provide low cost CG.

The system is equipped with an eight way intercom system and is supplied with four belt packs, headsets, and tally lights for effective communication among the whole production crew.

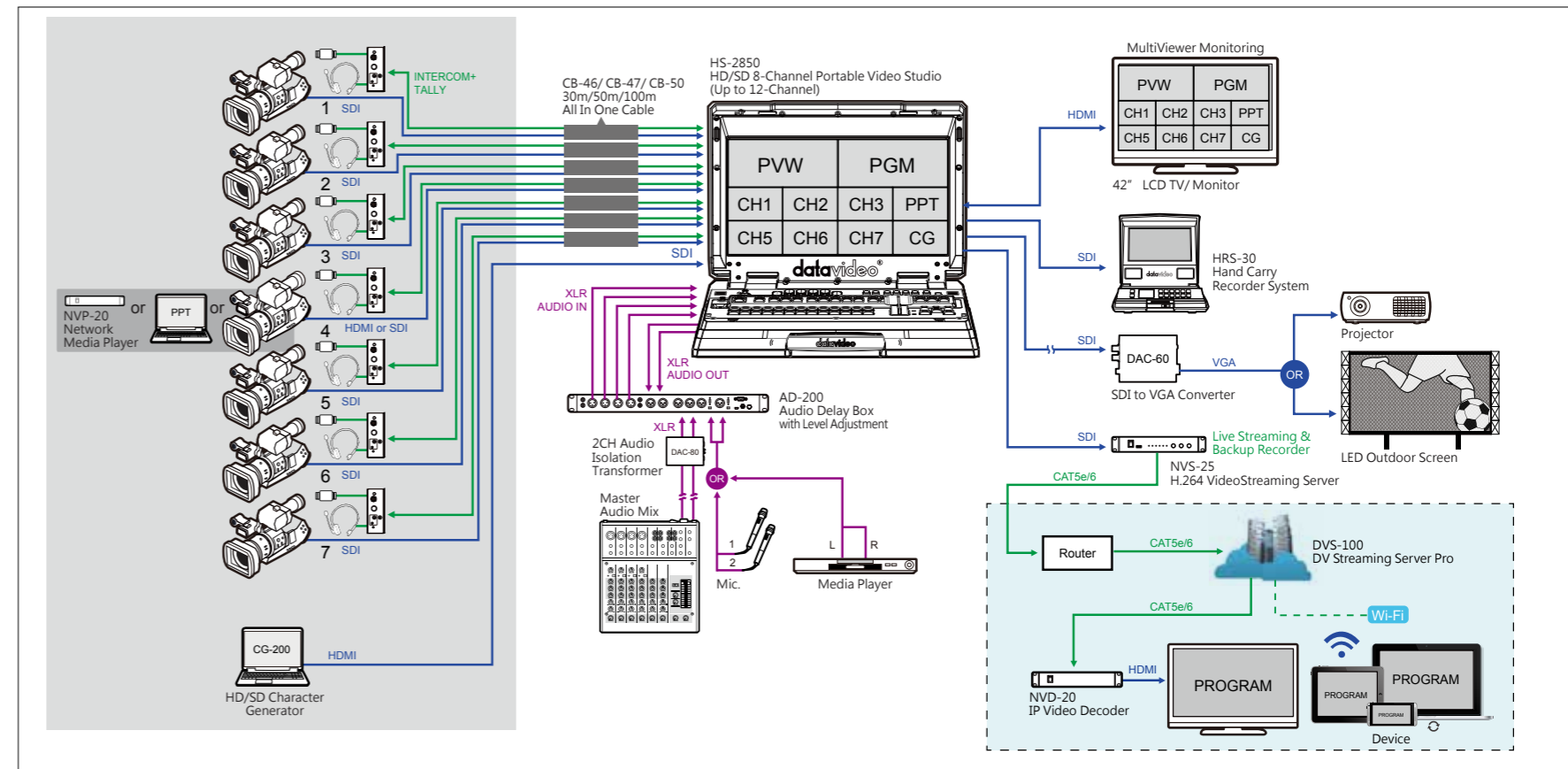

■ Video System

- Support FHD 1080P
- Standard 8 video input channels; expandable to 12 input channels by purchasing optional boards
- Supports 8 or 12 HD or SD Inputs in a variety of configurations:
 - HD Mode
 - (1) 8 / 12 HD-SDI (2) 6 / 9 HD-SDI + 2 / 3 HDMI
 - SD Mode
 - (1) 8 / 12 SD-SDI (2) 6 / 9 SDI + 2 / 3 HDMI
 - (3) 4 SDI + 4 CVBS (4) 4 SDI + 2 CVBS + 2 HDMI
- Video output: 3 x SDI-PGM or configurable to PGM, PVW, Clear PGM, and AUX with two channel down-converter to SD-SDI
- One channel for HDMI-Multiview output and can also be set to PGM-OUT
- Supports audio-embedded SDI input and XLR de-embedded port outputs XLR balance audio
- 4 x XLR analogue audio inputs and 2 x XLR analogue audio outputs
- Audio delay for each de-embedded audio source
- SMPTE/ EBU Audio selectable via OSD
- Black burst PAL or Tri-Level Sync Reference
- Supports GPI

■ Special Effects

- Built-in title overlay system (TC-200) that works with CG systems
- Dual PiP for news reporting and lecture recording
- Cut, Mix and Wipe with border

- XPT (Cross Point Assignment)
- Two channels of downstream key for applying subtitle and graphic effects; can also be set to Luma Key
- Two channel logo display with one channel for animated logo
- Audio-follow-Video switching for a synchronized audio-video switching during live news interview
- Three user defined HD/SD-SDI outputs

■ Intercom System

- Full-duplex system, which allows connection of external headset or microphone; high audio quality with low noise
- 8-way intercom with 4 belt-packs
- Bidirectional communication system and bi-color tally light indicators
- One-to-one or one-to-many communication mode
- Independent audio level adjustment on the main system and handsets

■ Monitor System

- Built-in 17.3 inch LCD screen, allowing the switcher to change the displayed video by switching between multiview, PGM and HDMI inputs
- Three screen color temperature settings: 9300, 7500 and 6500
- In multiview mode, the inputs and the PVW are equipped with dual track audio volume indicator and PGM is equipped with quad track audio volume indicator displayed on the screen
- PGM may be displayed in 4:3 or 16:9 mode when connected to an external HDMI display with the display of internal amplifier, audio volume, monitor video and monitor audio
- One 17.3-inch with a resolution of 1600x900 dots

HD/SD 12-Channel Portable Video Studio
HS-2800

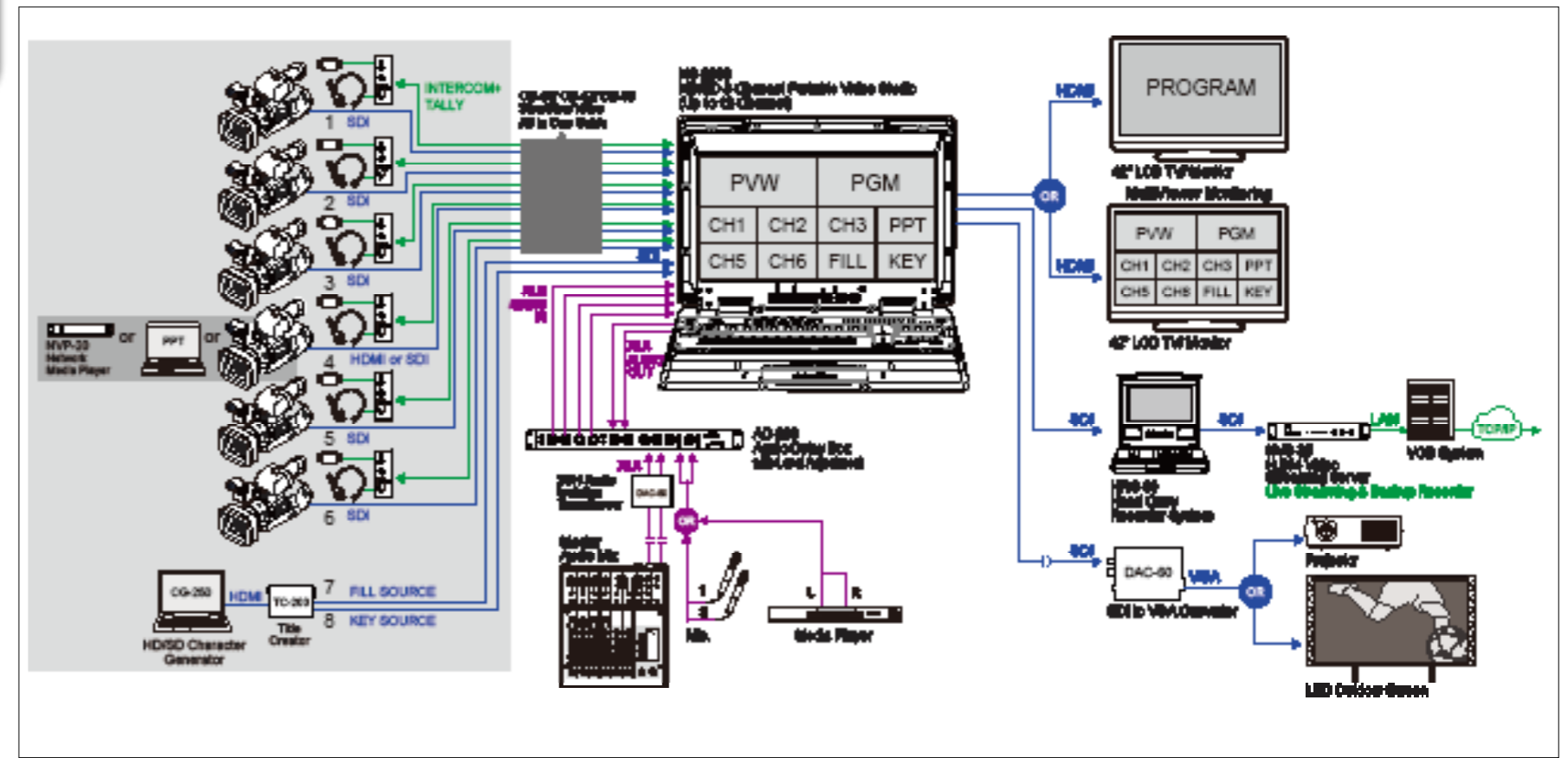

The complete HD mobile switcher

Multi-camera production is a required setup in most events, especially live broadcast of sporting events, concerts, and conferences. The switcher system must be equipped with more than 10 input channels as well as a character generator so as to deliver an engaging real-time experience

to the audience. The HS-2800 is a switcher equipped with 12 inputs and two built-in DSK channels, and can thus fully satisfy the requirement of any multi-camera events. The HS-2800 also has two channels for PIP to facilitate live remote broadcast of events or news programs.



■ Video System

- Standard 8 video input channels; expandable to 12 input channels by purchasing optional boards
- Video format: SDI, and HDMI inputs
- Video output: 2xSDI-PGM or configurable to PGM, PVW, Clear PGM, and AUX with two channel down-converter to SD-SDI
- One channel for HDMI-Multiview Output and can also be set to PGM-OUT
- Supports Audio-embedded SDI input and XLR De-Embedded port outputs XLR Balance Audio
- 4 Channels of XLR external LINE audio input, which can be embedded into SDI PGM output

■ Special Effects

- Dual PiP for news reporting and lecture recording
- Two channels of downstream key for applying subtitle and graphic effects; can also be set to Luma Key; the luma key function must be paired with PPT to generate basic subtitle effect
- Two channels logo display with one channel for animated logo ; TV station logo and program logo can be displayed at the same time and 8 logo files can be saved beforehand
- Audio-follow-Video switching for a synchronized audio-video switching during live news interview

■ Intercom System

- Full-duplex system, which allows connection of external headset or microphone; high audio quality with low noise
- 8-way intercom with 4 belt-packs
- Bidirectional communication system and bi-color tally light indicators
- One-to-one or one-to-many communication mode
- Independent audio level adjustment on the main system and handsets

■ Monitor System

- Built-in 17.3 inch LCD screen, allowing the switcher to change the displayed video by switching between multiview, PGM and HDMI inputs
- Three screen color temperature settings: 9300, 7500 and 6500
- In multiview mode, the inputs and the PVW are equipped with dual track audio volume indicator and PGM is equipped with quad track audio volume indicator displayed on the screen
- PGM may be displayed in 4:3 or 16:9 mode when connected to an external HDMI display with the display of internal amplifier, audio volume, monitor video and monitor audio

HD 6-Channel Portable Video Studio
HS-2200

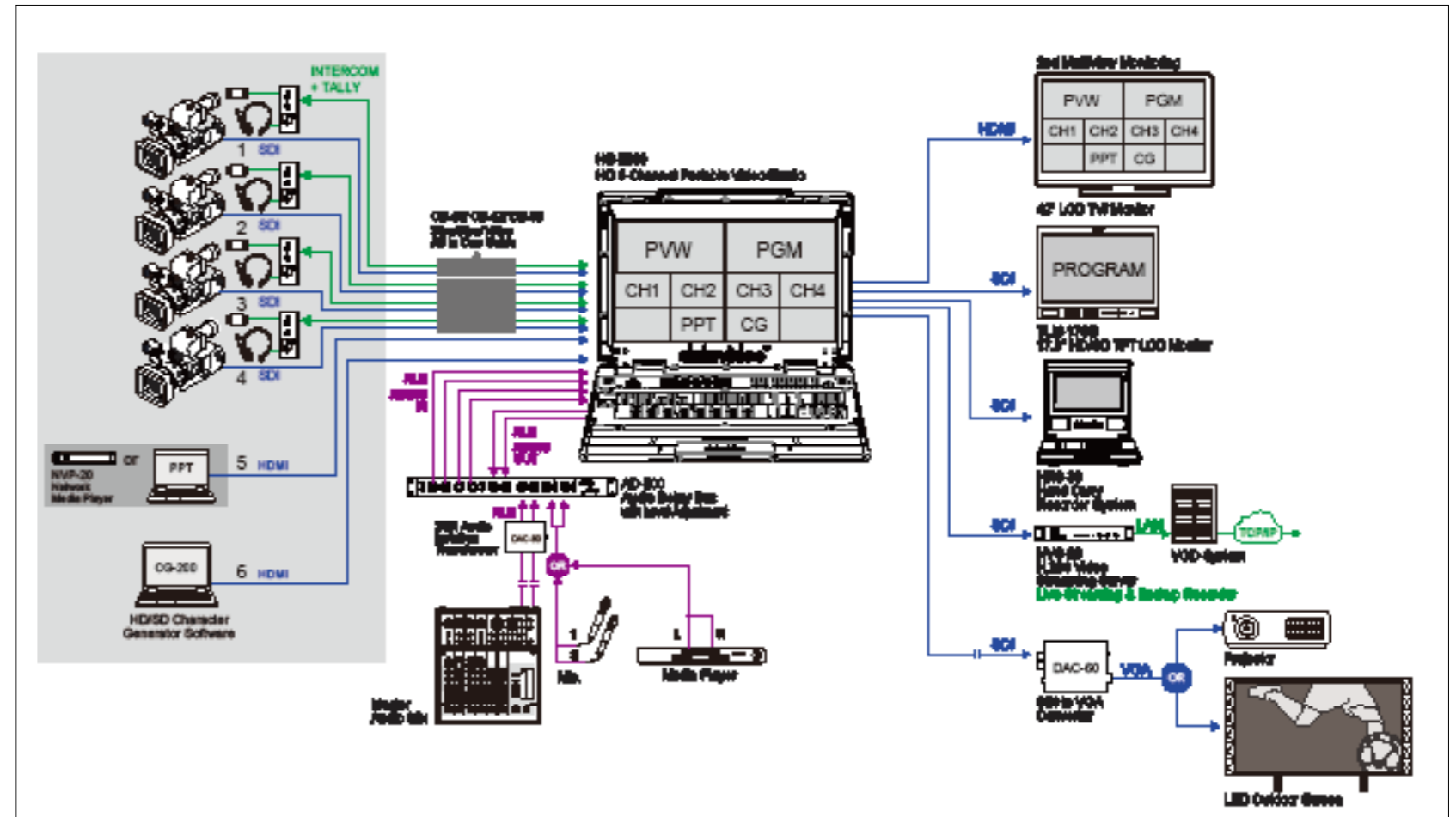

The first portable switcher with built-in CG!

HS-2200 is the flexible and versatile hand carry version of Datavideo SE-2200 switcher. With a 17.3" built-in monitor and 8 channel talkback/tally system, the whole system is packed into a durable case. HS-2200 is a convenient and powerful portable video studio for use in the most rough environments, and even runs on an optional external battery.

This production system integrates all the key components for live TV, video and AV programs. This includes source switching, visual or video mixing, crew comms, tally lights and the ability to feed live graphics and titles from any HDMI-enabled laptop. Small, portable and rugged, it's a design that's very well thought out for mobile production applications.



■ Video System

- 8 video inputs, select 6 at one time
- Video inputs of HD/SD System: 6xHD-SDI, 4xHD-SDI and 2xHD-HDMI
- Video outputs: 5xSDI assignable AUX 1-4, PGM, PVW or Clean PGM
- 2 key signals for setting DSK or Luma Key to create subtitle effects
- 2 PIP signals for setting the location and size of picture in picture
- Transition effects: CUT, WIPE and MIX with configurable transition countdown
- Built-in CG function paired with CG-200 Character Generator software; connect notebook computer to HS-2200 via HDMI interface (Optional CG-250 for more functions)

■ Audio System

- Built-in SDI audio de-embedding function; can be configured to de-embed from different switchable video inputs or de-embed from a single video channel
- 2 XLR terminals for audio output of audio de-embedded from video

- 4 XLR output terminals for connecting four external audio channels embedded into SDI video channel

■ Intercom System

- Full-duplex system, which allows connection of external headset or microphone; high audio quality with low noise
- 8-way intercom with 4 belt-packs
- Bidirectional communication system and bi-color tally light indicators
- One-to-one or one-to-many communication mode
- Independent audio level adjustment on the main system and handsets

■ Monitor System

- One 17.3-inch with a resolution of 1600x900 dots
- Screen has a built-in gray scale display for detecting external noise and provide video calibration
- In different environments, color temperature can be configured to 6500K, 7500K, 9300K or custom
- 16:9 or 4:3 display adjustable for camera shooting
- Editing or CG can be configured to 80% or 90% safe frame

HD/SD 4-Channel Portable Video Studio
HS-1500T

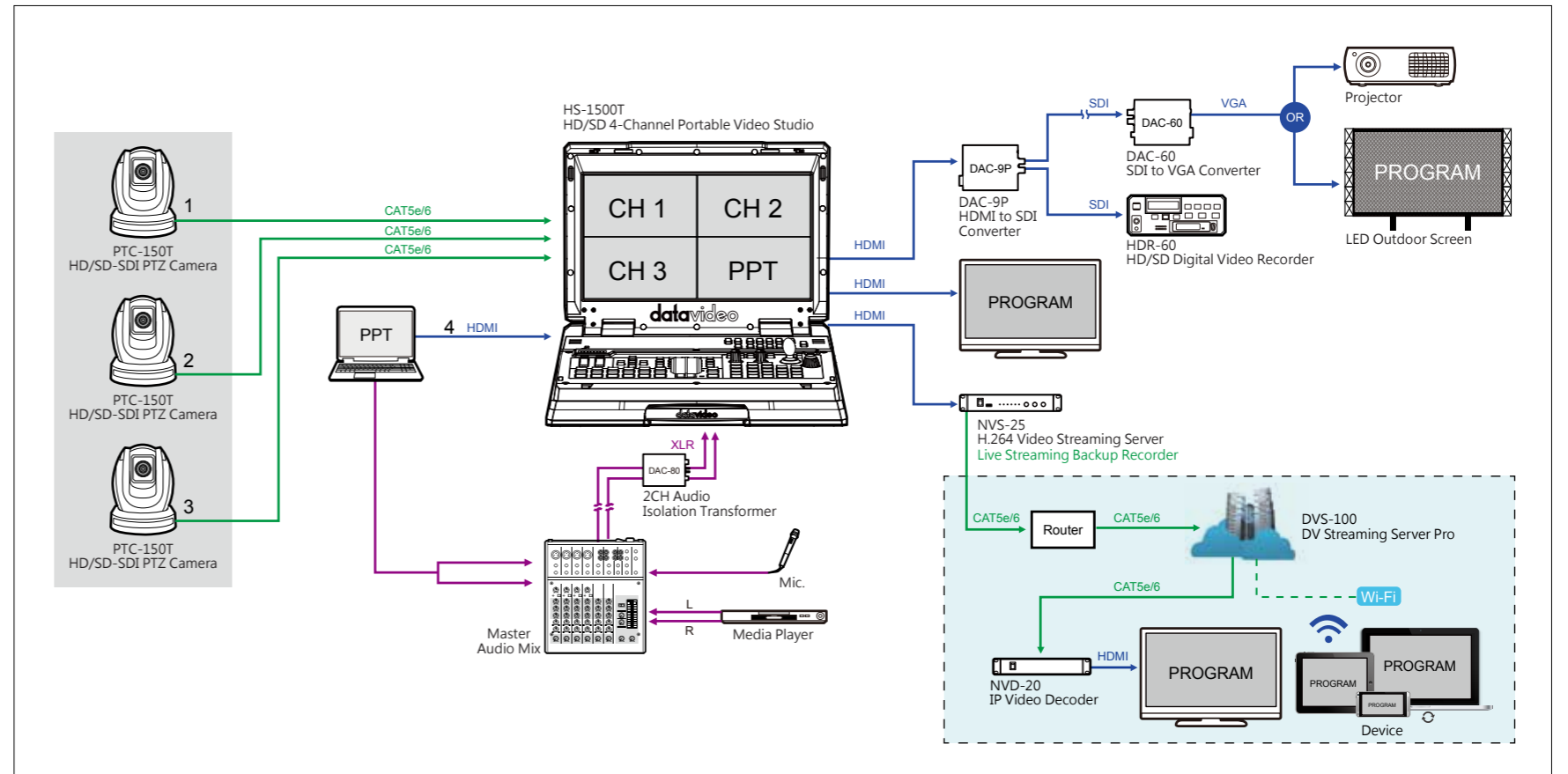

The world's first portable HDBaseT switcher

Datavideo's HS-1500T hand-carry mobile switcher supports full 1080P video and is designed for broadcast of live events and TV programs which use a wide variety of video and audio sources. The HS-1500T is also a highly valuable solution for the religion, education and AV markets.

Its built-in HDBaseT technology allows receiving of 1080p signals from three PTC-150T HDBaseT PTZ cameras via CAT5e or CAT6 cable. It features PoE to provide power to three PTC-150T devices, making camera installation fast and flexible.

The HS-1500T also features an audio mixer with balanced XLR inputs and unbalanced RCA audio inputs; other features include PIP, wipe generator and tally.

The HS-1500T joystick allows the user to pan, tilt and zoom the PTC-150T cameras. In addition, the HS-1500T also allows the user to adjust the PTC-150T's focus, iris and other settings remotely.



- Support FHD 1080P
- Built-in HDBaseT technology to control up to three Pan, Tilt and Zoom PTC-150Ts, and power to PTC-150Ts by PoE.
- Pan, tilt and zoom with speed control by Joystick
- 4 video inputs (RJ-45 x 3 + HDMI x 1)
- 3 video outputs (HDMI x 3)
- Audio inputs: XLR Analogue x 2 + RCA Analogue (L/R) x 2
- Flexible Mix/Effects : PIP, WIPE, Mix, Fade
- Tally Output
- One 17.3-inch with a resolution of 1600x900 dots

HD 6-Channel Portable Video Studio
HS-1200

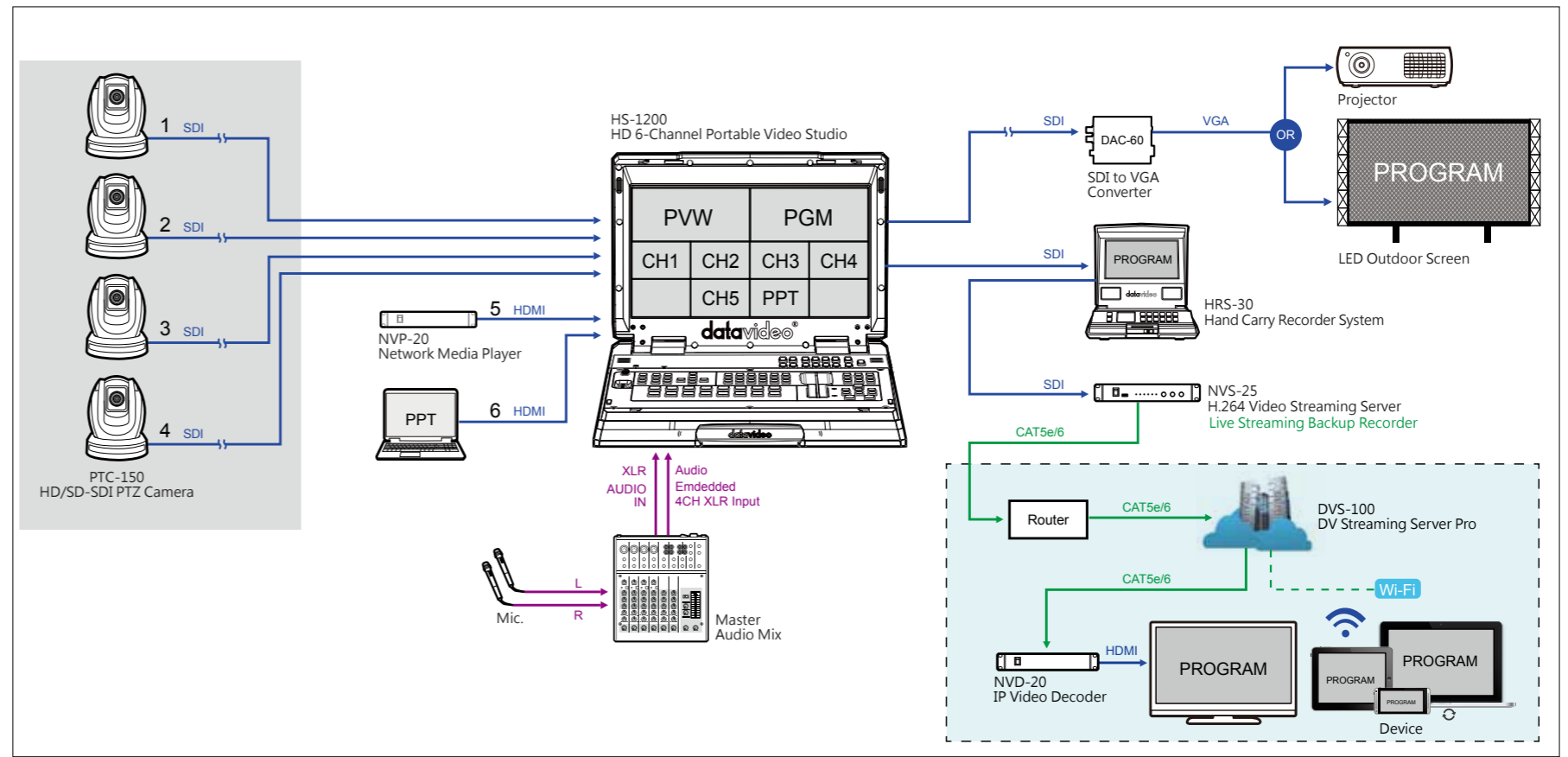

Portable switcher with dual channel chromakeyer

HS-1200 is the flexible and versatile hand carried version of Datavideo SE-1200 switcher. With a 17.3" built-in monitor and 6 channel HD vision mixer packed into a durable case, HS-1200 is a convenient and powerful portable video studio for use in any environment. It features a superb chromakey tool to add a whole new level of creativity to your production.

HS-1200 is designed for live events and TV programs that need to mix a variety of video and audio sources. It supports SDI and HDMI workflows and delivers high quality HD output.



■ Video System

- Video inputs: 6 (SDI x 4 + HDMI x 2)
- Video output: 3 (SDI x 2 + HDMI x 1)
- 2 up stream Keyers: Chromakey & Linear/ Luma Key
- 2 down stream Keyers: Linear & Luma Key
- 1 PIP (assignable to any of the 4 keyers)
- Transition effects: 32 Wipe Patterns, Cut and Mix
- Frame Store (Still's Store) from any Input (1-6)
- Assignable Outputs
- XPT (Cross Point Assignment)

■ Audio System



- 2 x XLR Analogue Audio Inputs
- Audio Indicator on MultiView

■ Monitor System

- 17.3-inch 1600x900 resolution monitor
- Color temperature can be configured to 6500K, 7500K, and 9300K or custom setting
- Adjustable 16:9 or 4:3 display
- CG can be configured to 80% or 90% safe frame

Digital Video Switchers

Model	HS-2850	HS-2800	HS-2200
			
Product name	HD/SD 12-Channel Portable Video Studio	HD/SD 12-Channel Portable Video Studio	HD/SD 6-Channel Portable Video Studio
Video Standard	HD & SD	HD & SD	HD & SD
Video Format	3G/HD/SD input : 1080i 50/59.94/60Hz 1080p 25/30/59.94/60Hz HD Output :1080i 50/59.94/60Hz SD: 576i 50Hz, 480i 59.94Hz	1080i 50/59.94/60Hz 576i 50Hz, 480i 59.94Hz	1080i 50/59.94/60Hz 720p 50/59.94/60 Hz 576i 50Hz, 480i 59.94Hz
Input Routable / Crosspoint	All 12, repeatable	Fixed	All 6, repeatable
Video Input	Standard: 8x SDI, 2x HDMI, 4x CV Max: 12x SDI, 3x HDMI, 6x CV	Standard: 8x SDI, 2x HDMI, 4x CV Max: 12x SDI, 3x HDMI, 6x CV	6x HD-SDI, 2x HDMI (on CH5 & 6)
Computer Graphic Interface	Max 3 via HDMI	Max 3 via HDMI	2 via HDMI
Down-converted output	2x SDI	2x SDI	N/A
Video output	3x SDI assignable: PGM, PVW, AUX & Clean Out 1x HDMI assignable: PGM & multi-view	2x SDI assignable: PGM, PVW, AUX & Clean Out 1x HDMI assignable: PGM & multi-view	5x SDI Outputs assignable: AUX 1-4, PGM, PVW, PGM Clean or multi-view 1x HDMI assignable: PGM or multi-view
Audio input	4x Balanced XLR	4x Balanced XLR	4x Balanced XLR
Audio output	2x Balanced XLR	2x Balanced XLR	2x Balanced XLR
Embedded audio support	Input up to 16 channels, Output 4 channels	Input up to 16 channels, Output 4 channels	Input up to 16 channels, Output 4 channels
Audio Delay Calibration	Up to 8 frames for SDI inputs	Up to 8 frames for SDI inputs	N/A
A+V switching	Yes	Yes	Yes
USK	N/A	N/A	N/A
DSK	2x DSK support Lumakey & Linear key (Key / Fill)	2x DSK support Lumakey & Linear key (Key / Fill)	1x DSK support Lumakey & Linear key (Key / Fill)
Picture in Picture	2	2	2
Logo Insertion	2 (or 1 logo + 1 clock)	2 (or 1 logo + 1 clock)	2 (or 1 logo + 1 clock)
Built-in Audio Mixer	N/A	N/A	N/A
Built-in Monitor Display		17.3" HD TFT LED back-lit, 1600x900 pix	
Built-in Intercom & Tally	8 channels (4 belt-packs incl.)	8 channels (4 belt-packs incl.)	8 channels (4 belt-packs incl.)
Dimension (LxWxH)		455 x 355 x 134 mm	
Weight	19.6 Lbs (9 Kg), Reinforce Plastic Case	19.6 Lbs (9 Kg), Reinforce Plastic Case	19.6 Lbs (9 Kg), Reinforce Plastic Case
Accessory		CB- 46/ 47/ 50	

Model	HS-1500T	HS-1200
		
Product name	HD/SD 4-Channel Portable Video Studio	HD 6-Channel Portable Video Studio
Video Standard	HD & SD	HD
Video Format	1080p 50/59.94/60Hz , 1080i 50/59.94/60Hz 720p 50/59.94/60Hz , 576i 50Hz , 480i 59.94Hz	1080i 50/59.94/60Hz 720p 50/59.94/60Hz
Input Routable / Crosspoint	N/A	All 6, repeatable
Video Input	3 x HDBaseT , 1 x HDMI	4x HD-SDI , 2x HDMI
Computer Graphic Interface	1 via HDMI	2 via HDMI
Down-converted output	N/A	N/A
Video output	3x HDMI assignable:PGM or multi-view	1 HDMI + 2 SDI assignable: AUX 1-6, PGM, PVW, PGM Clean or multi-view
Audio input	2x Balanced XLR , 1x Stereo RCA (L/R) , De-embedded Digital Audio	2x Balanced XLR
Audio output	1x Stereo headphone	1x Stereo headphone
Embedded audio support	2 ch Audio embedded	2 ch Audio embedded
Audio Delay Calibration	N/A	N/A
A+V switching	N/A	N/A
USK	1x USK	2x USK support Chromakey
DSK	N/A	2x DSK support Lumakey & Linear key (Key / Fill)
Picture in Picture	1	1
Logo Insertion	N/A	N/A
Built-in Audio Mixer	Yes	selectable audio follow video master gain control
Built-in Monitor Display		17.3" HD TFT LED back-lit, 1600x900 pix
Built-in Intercom & Tally	N/A	N/A
Dimension (LxWxH)		455 x 355 x 134 mm
Weight	18 Lbs (9 Kg), Reinforce Plastic Case	17.6 Lbs (8 Kg), Reinforce Plastic Case
Accessory	N/A	CB-22H/23H/46/47/50

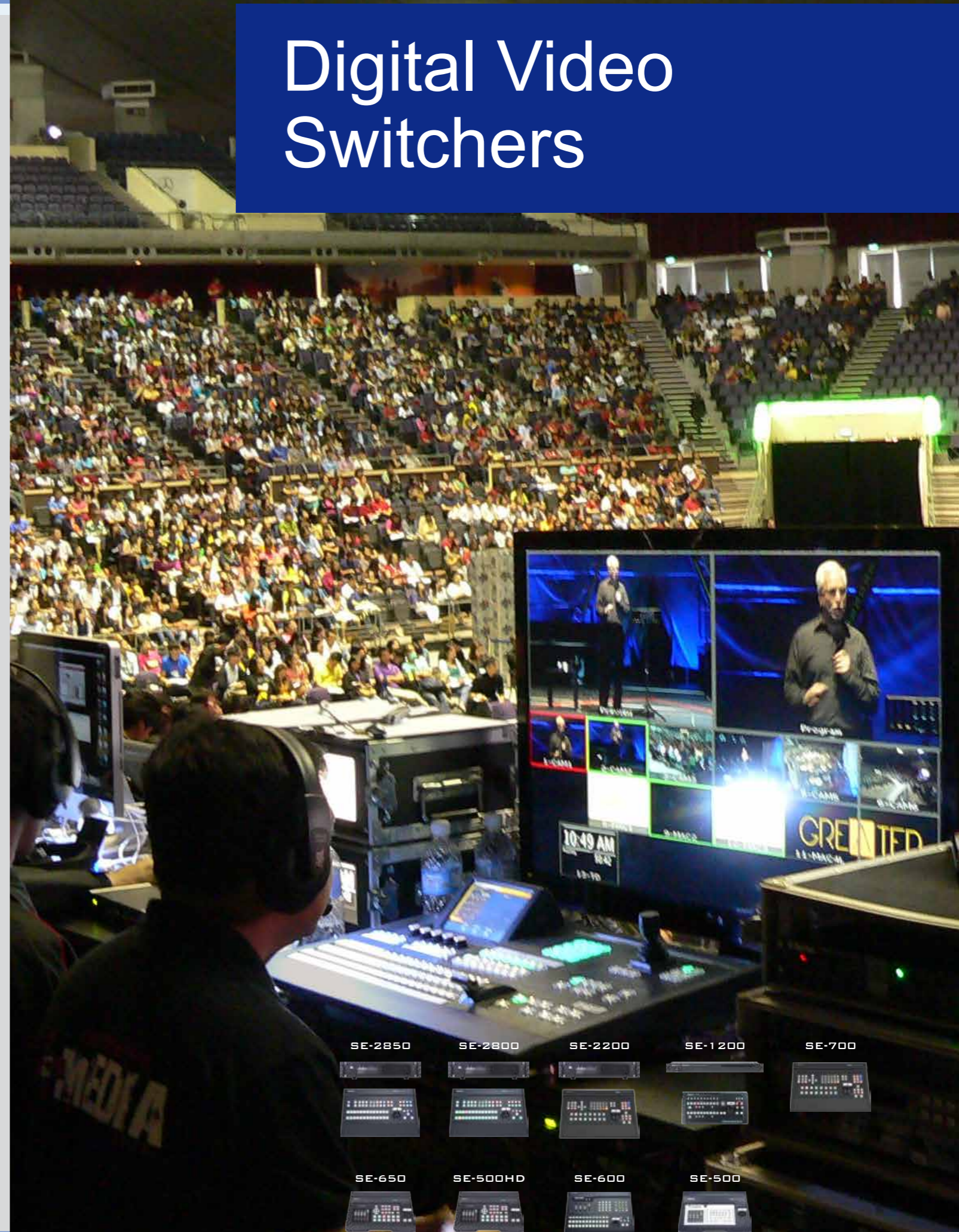

HD/SD 12-Channel Digital Video Switcher SE-2850

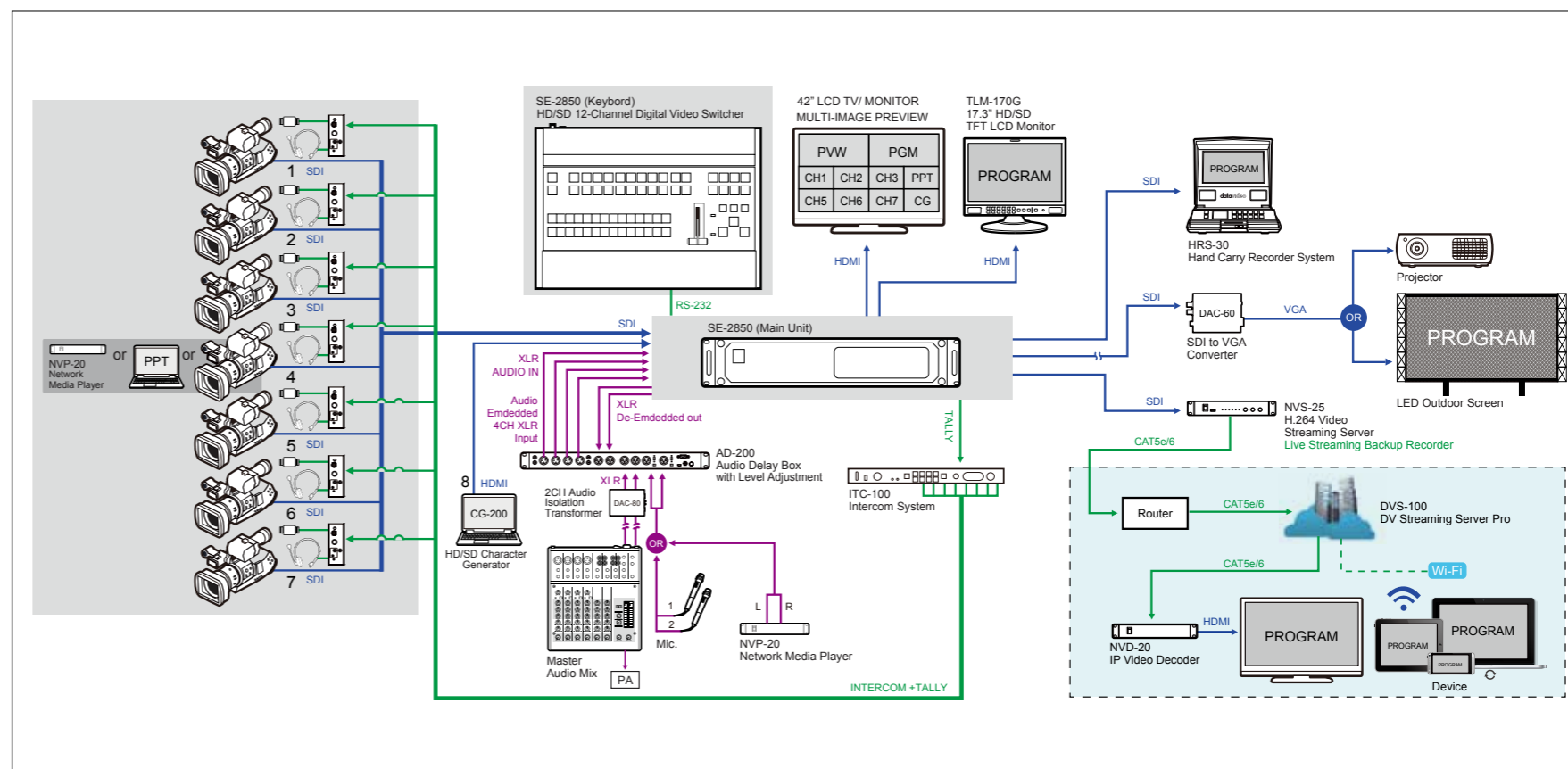

Flexible and updated 8-12 channel HD/SD switcher!

The SE-2850 is equipped with 12 input channels (standard: 8 channels; optional: 12 channels) and is compatible with HD or SD production. The two-piece design allows easy system integration into standard equipment racks. The SE-2850 is a cost-effective switcher system for use in live events, sub-control rooms or outdoor broadcast vans. SE-2850 is equipped with 3G-SDI input and two HDMI outputs, which allow four types of multiview modes: the

operator can customize their own output configuration. There is an audio volume indicator displayed on each input screen for the operator to monitor video and audio at the same time. SE-2850 has built-in Datavideo TC-200 CG interface, which supports CG system by a laptop computer into one of the HDMI inputs.

- 8 or 12 video inputs (3G/HD/SD-SDI, HDMI & CVBS)
- 4 assignable SDI outputs + 2 assignable HDMI outputs
- Video Input :
 - 3G/HD/SD input :
 - 1080i 50/59.94/60Hz
 - 1080p 25/30/59.94/60Hz
 - HD Output :1080i 50/59.94/60Hz
 - SD: 576i 50Hz, 480i 59.94Hz
- Built-in Datavideo TC-200 CG interface, supports CG system by a laptop computer
- Flexible Mix/Effects Processor with:
 - Dual PIP effect
 - 2 DSK : Alpha channel & Luma Key Modes
- Logo: 2 independent Logos and 1 dynamic logo or moving image sequence.
- XPT (Cross Point Assignment)
- Frame store (Stills Store): Each input channel
- Real-time clock and count down on multiview screen
- Up to 8 frames audio delay for each de-embedded audio from input source
- 4 x XLR balance Audio input (Line level), 4-CH embedded SDI Audio output
- Audio indicator display on multiview screen
- Support Audio cross point (Audio XPT) or Audio-follow-Video mode (A+V)
- Selectable SMPTE/ EBU Audio via OSD Menu
- 2 GPI mode: Level /Pulse trigger selectable
- RS-422/RS-232 remote control interface
- Tally output
- Separated control panel and processor unit for flexible installation
- External Sync/Genlock: Black Burst & Tri-level

HD/SD 12-Channel Digital Video Switcher SE-2800

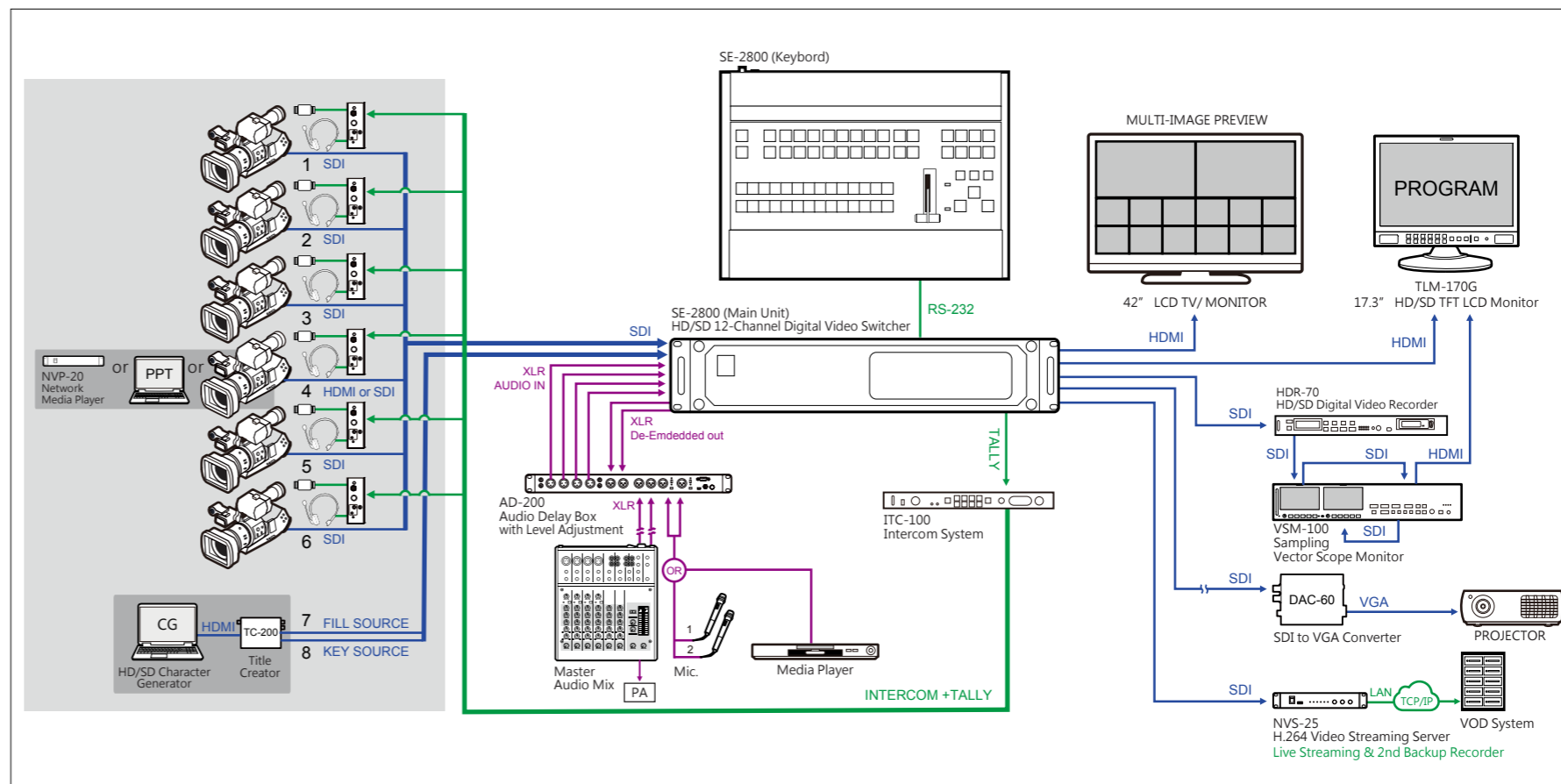

Flexible 8-12 channel HD/SD switcher!

The SE-2800 is equipped with 12 input channels (standard: 8 channels; optional: 12 channels) and is compatible with HD or SD. The two-piece design allows easy system integration into standard equipment racks. Despite this level of functionality, SE-2800 is surprisingly affordable. The SE-2800 is a cost-effective switcher system for use in live events, sub-control rooms or outdoor broadcast vans. SE-2800 is equipped with

two HDMI outputs, which allow four types of multiview modes: the operator can customize their own output configuration. There is an audio volume indicator displayed on each input screen for the operator to monitor video and audio at the same time.



- 8 or 12 video inputs (HD/SD-SDI, HDMI & CVBS)
- 3 assignable SDI outputs + 2 HDMI outputs for multi-view monitoring
- Flexible Mix/Effects Processor with:
 - Dual PIP effect
 - 2 DSK : Alpha channel & Luma Key Modes
- Logo: 2 independent Logos and 1 dynamic logo or moving image sequence.
- Frame store (Stills Store): Each input channel
- Real-time clock and count down on multiview screen
- Up to 8 frames audio delay for each de-embedded audio from input source
- 4 x XLR balance Audio input (Line level), 4-CH embedded SDI Audio output
- Audio indicator display on multiview screen
- Support Audio cross point (Audio XPT) or Audio-follow-Video mode (A+V)
- 2 GPI mode: Level /Pulse trigger selectable
- RS-422/RS-232 remote control interface
- Tally output
- Separated control panel and processor unit for flexible installation

HD/SD 6-Channel Digital Video Switcher SE-2200

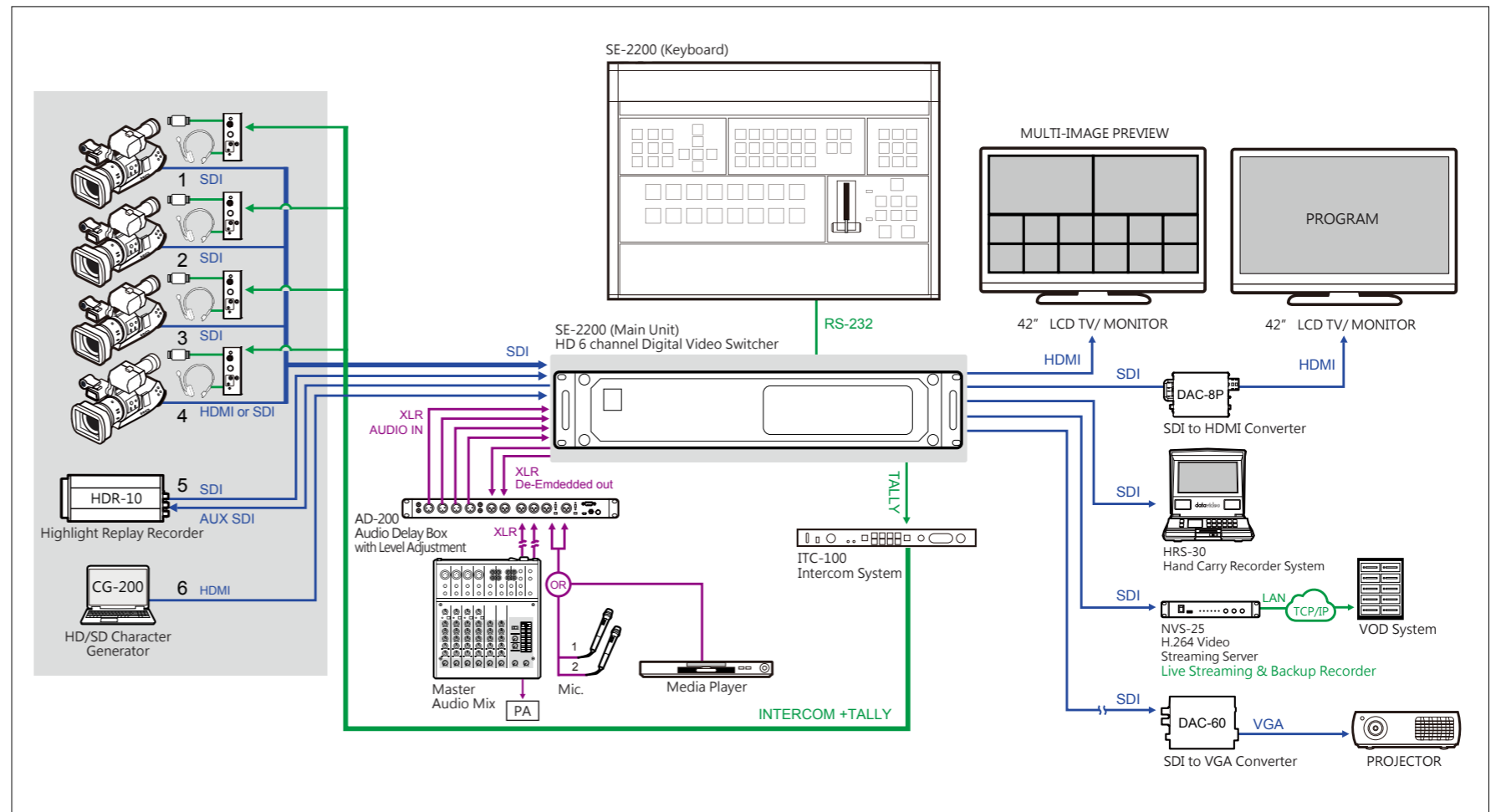

HD/SD switcher with effortless graphic overlay!

There are more and more peripheral devices to be integrated into the production system. Even the switcher equipment used in small-scale productions require multiple input and output ports and should be able to accept various input signal formats. The SE-2200 is a video switcher designed specifically for small-scale events, lecture

recording, and studio applications, equipped with 6 HD/SD input ports with two configurable to HDMI input ports to allow connection of computers to the switcher. Built-in Datavideo TC-200 CG interface, supports CG system by a laptop computer into one of the HDMI inputs.



- 6 video inputs (SDI x 6 or SDI x 4 + HDMI x 2)
- 6 assignable SDI outputs + 2 HDMI outputs
- Built-in Datavideo TC-200 CG interface, supports CG system by a laptop computer
- Flexible Mix/Effects Processor with:
 - 1 DSK : Luma Key
 - 2 PIP
 - 17 Wipe and Fade; a total of 18 transition modes
 - Wipe, Mix & Cut Transitions

- Allows SDI-Embedded input; internal de-embedding of audio from video and output via XLR port
- Four external audio input ports, embed audio into SDI to achieve a four-audio-track output
- RS-422/RS-232 remote control interface
- Tally output
- Separated control panel and processor unit for flexible installation

HD 6-Channel Digital Video Switcher

SE-1200

SE-1200MU+RMC-260

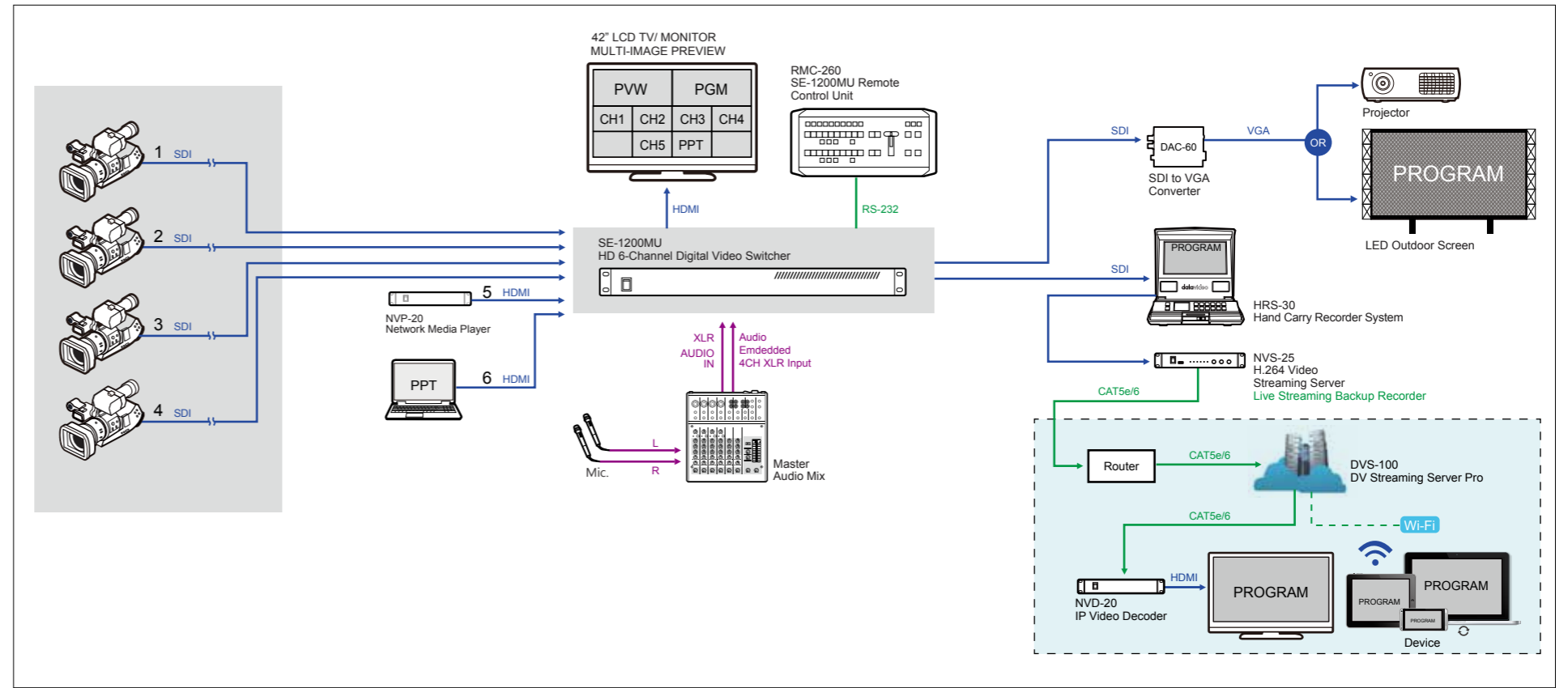

Video everywhere with Remote Control

Whether you are filming a seminar or conference, producing a live event or shooting in a production studio, the Datavideo SE-1200MU HD video switcher enables you to switch seamlessly between video sources and blend high-quality digital content on the fly.

SE-1200MU is a small, portable computer controlled 1RU rack mountable switcher. It features 6-channel HD video inputs and is incredibly reliable, unlike PC-based systems that are prone to crashing mid production. SE-1200MU streams out multi-view video in real-time to a PC for monitoring and controlling remotely. It is designed to be fully controlled from any Windows Laptop / PC and Android tablet / iPad / Mac with the included SE-1200 software or via an

optional hardware control panel. SE-1200MU includes four SDI and two HDMI inputs and an internal frame synchronizer so you can use sources without genlock such as consumer HDMI cameras or even computers for live PowerPoint presentations. The system includes two assignable SDI and two HDMI outputs for connecting an HD recorder, monitor and a streaming encoder, plus two balanced XLR audio inputs for connecting an external audio mixers. Other features include chromakey, lumakey, DSK, PIP, still stores, tally and RJ-45/ RS-232 remote control interface. The RMC-260 hardware controller is designed specifically for controlling the SE-1200MU. The RS-232 interface allows direct plug-and-play connection without any network configuration.



SE-1200MU Key Functions

- 6 video inputs (SDI x 4 + HDMI x 2)
- 2 assignable SDI outputs + 2 HDMI assignable outputs
- Flexible Mix/Effects Processor with:
 - 2 Chromakey
 - 2 DSK, supporting Linear & Luma Key Modes
 - 1 PIP : assignable to any of the 4 keys
 - Wipe Generator: 32 Wipe Patterns
 - Stinger transition
 - Wipe, Mix & Cut Transitions
 - Full M/E Preview function
- Frame store (Stills Store): 1000+ images stored on SD Card
- XPT (Cross Point Assignment)
- PC & Tablet control
- Remote streaming of multiview out using built-in Motion JPEG Streaming processor
- Tally output
- GPI output
- 1U rack mount
- Multi-language

RMC-260 Key Functions

- A switcher style keyboard for SE-1200MU operation
- Support keys enable and function assignment quickly
- Save user behavior to user memory keys and load them quickly
- XPT (Cross Point Assignment)
- Take button to switch between PVW and PGM views
- FTB button fades the PGM view to a black screen
- Still Grab function captures the instantaneous video image
- RS-232 interface for communication between RMC-260 and SE-1200MU

HD 4-Channel Digital Video Switcher SE-700

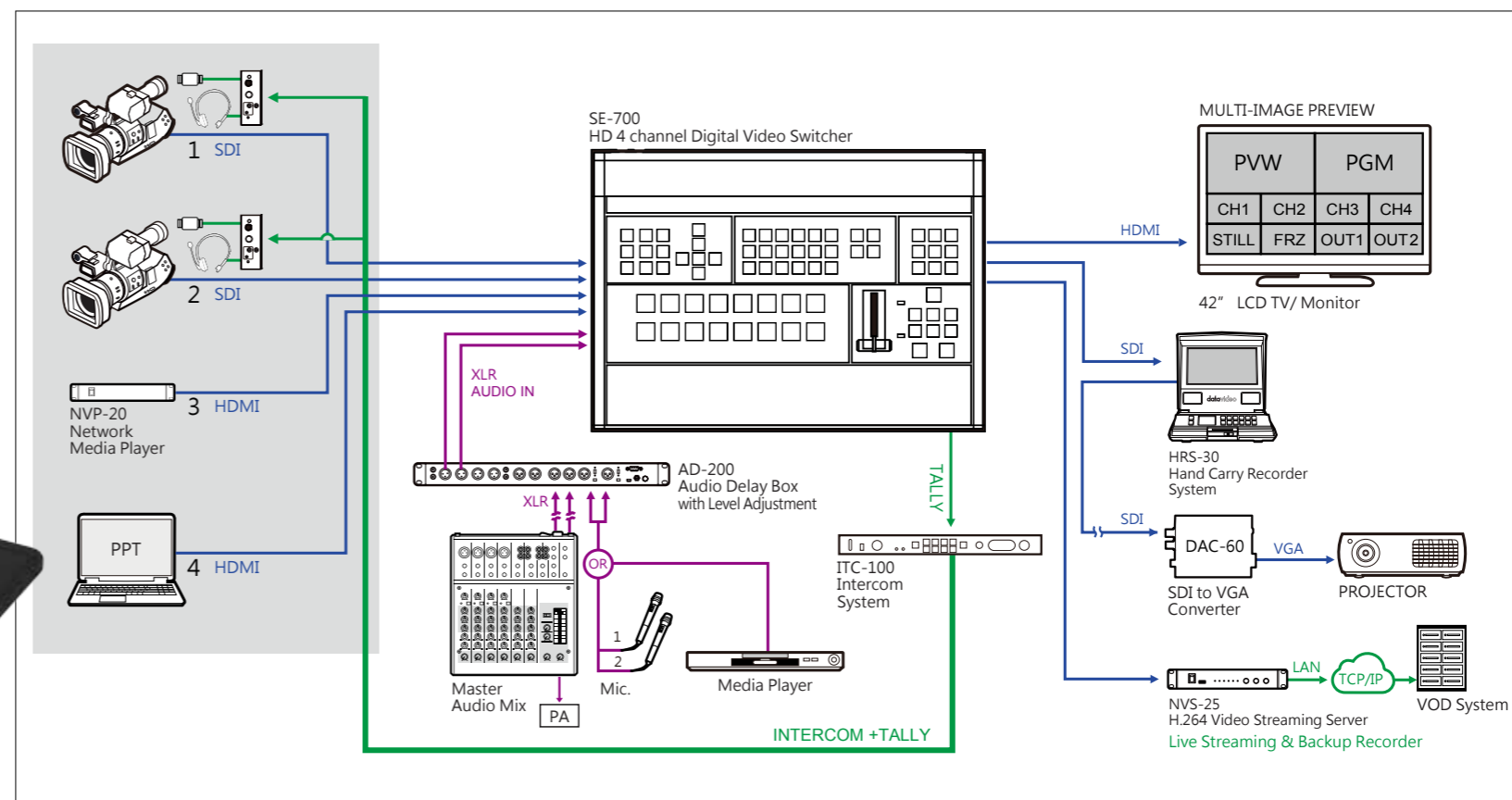

Cost-Effective 4-input HD Switcher with chromakeyer

Video switching technology has come a long way over the years. No longer is it necessary to have a giant console full of confusing controls. Much can be accomplished these days using only a computer, webcams and a software-based switcher. However, most live producers still need a dedicated hardware panel for quick and accurate switching. That's where the Datavideo SE-700 comes in. SE-700 comes with a total of four video inputs, two SDI and two HDMI, all with XPT function (Cross Point Assignment), There's one upstream keyer, supporting chromakey and linear/lumakey as well as one upstream PIP, supporting chromakey and lumakey modes as well as unkeyed mode. For transitions, SE-700 comes with

a wipe generator that contains 32 patterns, with borders and softness control, along with cut and mix options. It also features one DSK and a full M/E preview function. A built-in frame store has a dedicated stills buffer with up to 24 images stored on an SD card. 2xSDI and 1xHDMI outputs are available on SE-700. Each SDI output can be switched in the menu as: Program (w/ DSK), clean program (w/o DSK), clean preview (w/o DSK), multi-screen or input 1-4. An on-screen menu system gives easy access to settings, tally and GPI outputs, and the SE-700 has additional control options that can be accessed from a tablet or computer.



- 4 video inputs (SDI x 2 + HDMI x 2)
- 2 assignable SDI outputs + 1 HDMI assignable output
- Flexible Mix/Effects Processor with:
 - 1 Chromakey
 - 1 DSK, supporting Linear & Luma Key Modes
 - 1 PIP : assignable to any of the 4 keys
 - Wipe Generator: 32 Wipe Patterns
 - Stinger transition
 - Wipe, Mix & Cut Transitions
 - Full M/E Preview function
- 12 user-defined custom configurations
- 2 audio Input (Balanced XLR x 2)
- XPT (Cross Point Assignment)
- 1000+ Frame store
- Tally output
- Multi-language

HD 4-Channel Digital Video Switcher SE-650



Complete and compact HD switcher with built-in audio mixer

The Datavideo SE-650 is a small, cost-effective, professional HD digital video switcher. It offers two HD-SDI and two HDMI inputs and supported video formats up to 1080P. It features two HDMI outputs, a user assignable HD-SDI output and an Ethernet port for streaming. The SE-650 is the perfect device for small scale video production using professional cameras and HDMI equipment.

The SE-650 also features audio mixer with microphone and unbalanced RCA audio inputs, and advanced tools including Chromakey, Luma key, PiP, wipe generator, still store and tally.

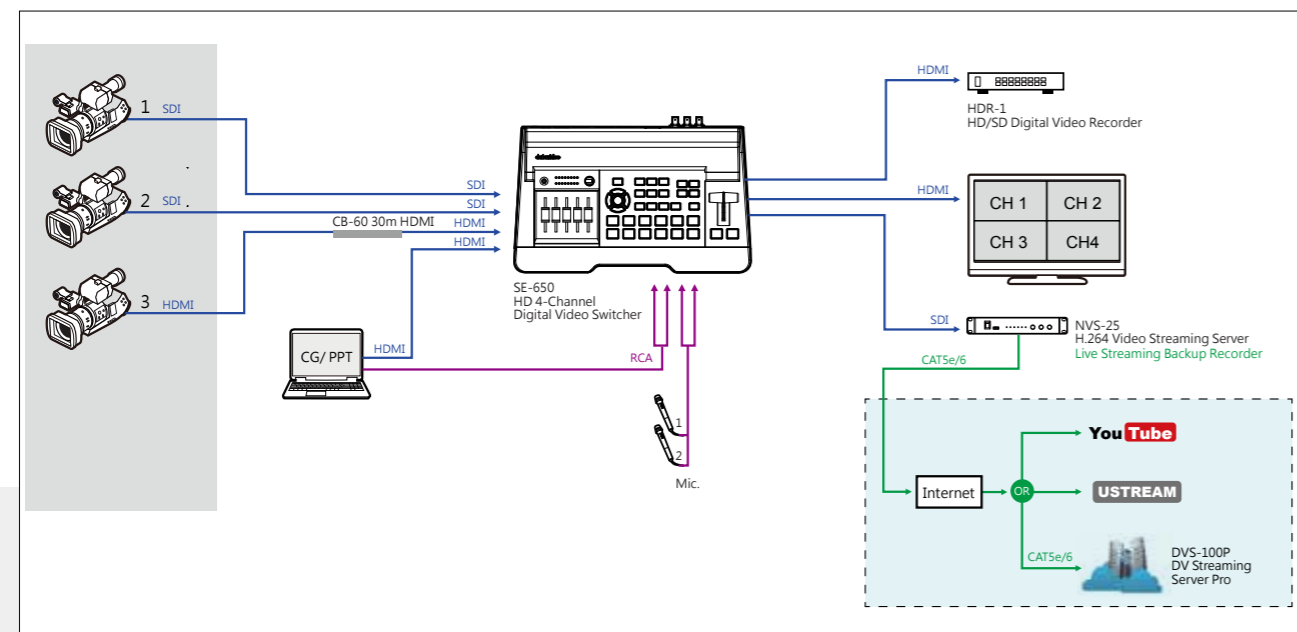

- 4 video Input : HD-SDI x 2 + HDMI x 2
- 3 Video Output : HD-SDI x 1 + HDMI x 2
- Any Input can be used as a Frame store (Stills Store)
- Assignable Outputs
 - Program (w/ DSK)
 - Clean Program (w/o DSK)
 - Clean Preview (w/o DSK)
 - Multiview
- Frame Sync on each input
- Flexible Mix/Effects Processor with
- 1 Upstream Keyer, supporting Chromakey & Linear/Luma Key
- 1 Upstream PIP, supporting Chromakey & Luma Key
- Full M/E Preview function

- Wipe Generator: 32 Wipe Patterns, including Circle & Heart - Borders & Softness Control
- Logo insertion (Animation logo, X/Y size)
- XPT (Cross Point Assignment)
- Tally Output
- 6 Channel Audio Mixer
- Audio input : RCA Analogue (L/R) x 2 + Microphone x 2
- Audio output : RCA Analogue (L/R) x 2 + Stereo head-phone mini Jack x 1
- Audio em-bedded function
- 4:2:2 10 bit
- 1000+ Frame Store
- Audio follow video
- Multi-language

HD/SD 4-Channel Digital Video Switcher SE-500HD



Fast and effective HDMI switching!

The Datavideo SE-500HD is a small, cost-effective and easy-to-use HD/SD digital video switcher. It offers 4 HDMI inputs and 2 HDMI outputs, and supports video formats up to Full HD 1080P. The SE-500HD is the perfect companion for smaller productions using HDMI cameras and other HDMI equipment.

The SE-500HD features an audio mixer with microphone and unbalanced RCA audio inputs, RCA audio outputs. Other features include PiP, wipe generator and tally.

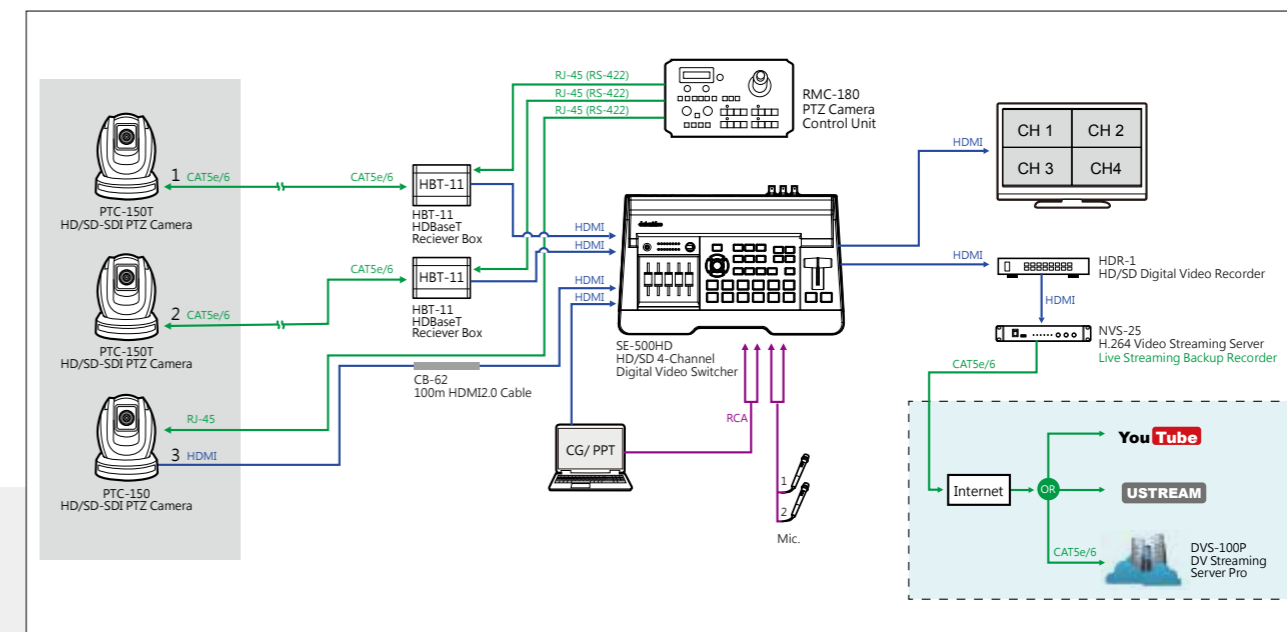

- Support FHD 1080P
- 4 video input : HDMI x 4
- 2 video output: HDMI x 2
- Frame Sync on each input
- PIP (Picture-in-Picture)
- Flexible Mix/Effects Processor with:
 - Wipe, Mix & Cut Transitions
- Full M/E Preview function

- Tally Output
- 4 Channel Audio Mixer
- Audio input :
 - RCA Stereo x 1 + Microphone x 2
- Audio output :
 - RCA Stereo x 1 + Stereo head- phone mini Jack x 1
- Audio em-bedded function

SD 8-Channel Digital Video Switcher
SE-600

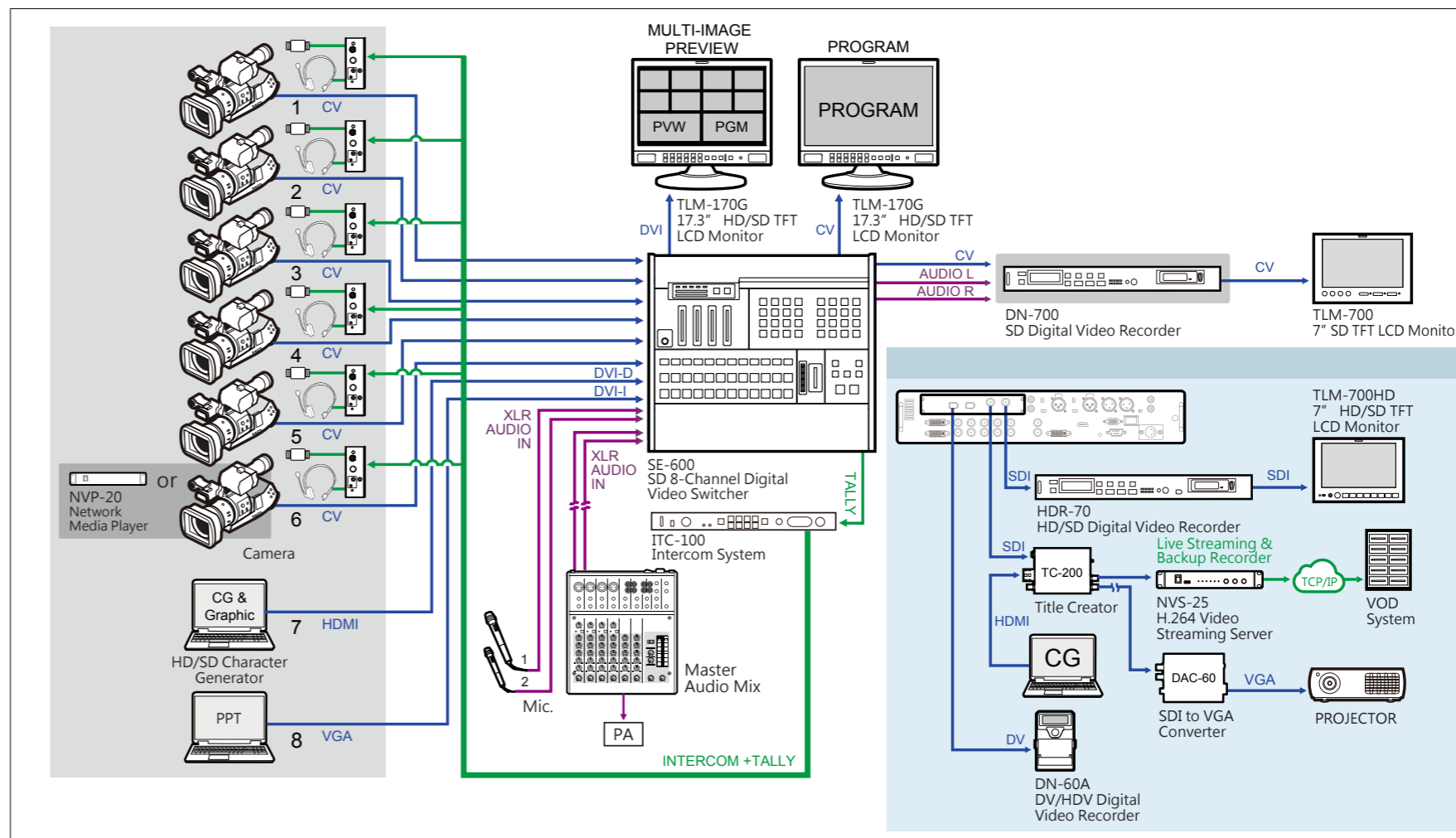

6-input SD switcher with built-in audio mixer

Even though video transmission via SDI has already become mainstream, there are still many analog cameras in use today. Yet few manufacturers offer professional switchers with sufficient analog connections. The SE-600 is designed for analog workflows with of 6 composite video (CV) inputs. In

order to satisfy applications involving computer and other external video sources, two additional DVI input ports are included. As for audio, two XLR or RCA input ports are available as well as a sound mixer to process audio in real time during live production.



- 8 video inputs (CV x 6 + DVI-D or HDMI x 1 + DVI-I or VGA x 1)
- 8 video outputs
- Support of 16:9 and 4:3 aspect ratio
- Flexible Mix/Effects Processor with:
 - 2 PIP
 - 1 DSK, supporting Luma Key
- Wipe Generator: 14 Wipe Patterns
- FTB, Wipe, Mix, Cut, Mosaic, Paint, and Monochrome transitions
- Optional Digital Output Board: 2 x DV25 (IEEE-1394) and 2 x SDI.
- 4 audio Input (Balanced XLR x 2 + Unbalanced RCA x 2)
- 4 audio output (Balanced XLR x 2 + Unbalanced RCA x 2)
- Audio-follow-Video mode (A+V)
- Hot key functions
- Dual logo store
- Tally output
- RS-422 and GPI output for controlling external devices

SD 4-Channel Digital Video Switcher
SE-500

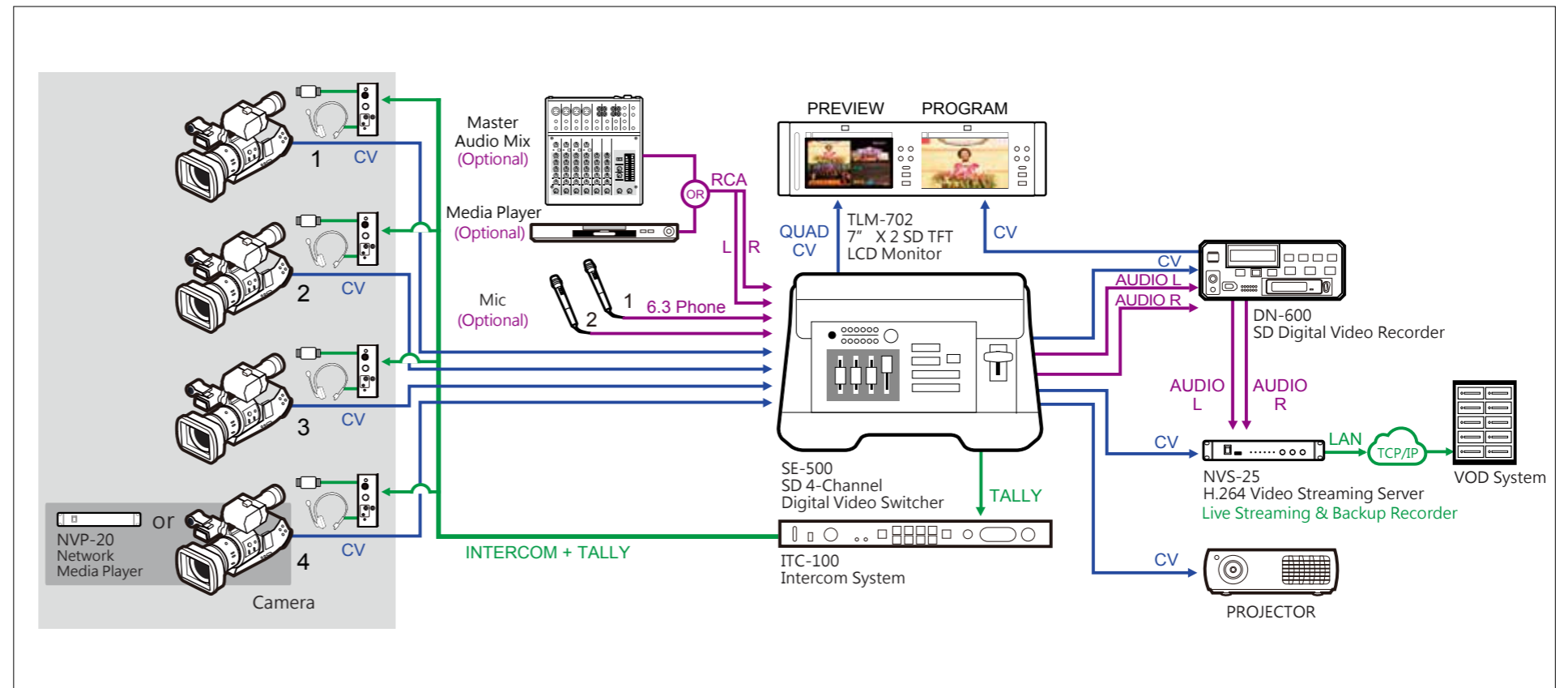

All time classic composite switcher!

It typically takes at least three cameras to produce live events. This is the case whether the production takes place in a school, sports event, seminar, studio or conference room. Two cameras are used to shoot the speaker on the stage from different angles and another camera shoots the audience. The videos captured by the three different cameras are played alternately to achieve a complete

broadcast-style programming. The SE-500 quickly switches between cameras. The operator should first choose the required shooting image of a desired angle and the images are switched using different ways, ultimately recording them on the hard disk in a pre-determined sequence.



Key Functions

Four-split multiview preview output requires only one monitor cutting down the cost of three screens

The SE-500 has a multiview preview that allows the user to save the cost of three preview monitors. This multiview preview function is able to output tally light signals and display transition effects simultaneously thus allowing the production team to operate the SE-500 while monitoring the input source, shooting cameras and control transition effect. The small-size SE-500 is equipped with the features of a high-end switcher at an affordable price.

Quad split screen

Tally and special effect mode display



Two microphones and one audio input port, allow live voice to be captured by the microphone and prevent noises from being captured by the camera.

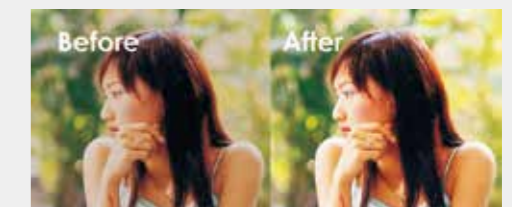









Image quality adjustment; video inputs can be adjusted to match for consistent output.

Model	SE-2850	SE-2200	SE-1200MU	SE-700
				
Video Standard	HD & SD	HD & SD	HD	HD
Video Format	3G/HD/SD input : 1080i 50/59.94/60Hz 1080p 25/30/59.94/60Hz HD Output :1080i 50/59.94/60Hz SD: 576i 50Hz, 480i 59.94Hz	1080i 50/59.94/60Hz 720p 50/59.94/60 Hz 576i 50Hz, 480i 59.94Hz	1080i 50/59.94/60Hz 720p 50/59.94/60Hz	1080i 50/59.94/60Hz 720p 50/59.94/60Hz
Video Processing	SDI: 4:2:2 HDMI: YUV 4:2:2 10 bit, RGB 4:4:4	SDI: 4:2:2 HDMI: YUV 4:2:2 10 bit, RGB 4:4:4	SDI: 4:2:2 HDMI: YUV 4:2:2 10 bit, RGB 4:4:4	SDI: 4:2:2 HDMI: YUV 4:2:2 10 bit, RGB 4:4:4
Input Routable / Crosspoint	All 12, repeatable	All 6, repeatable	All, repeatable	All 4, repeatable
Video Input	Standard: 8x SDI, 2x HDMI, 4x CV Max: 12x SDI, 3x HDMI, 6x CV	6x HD-SDI, 2x HDMI (on CH5 & 6)	4x HD-SDI 2x HDMI (RGB/ YUV/1080i/1080p/720p)	2xHD-SDI 2xHDMI
Mix HD & SD source	Yes	N/A	N/A	N/A
Computer Graphic Interface	Max 3 via HDMI	2 via HDMI	2 via HDMI	2 via HDMI
Video output	4x SDI assignable: PGM, PVW, AUX1-3 & Clean Out 2x HDMI assignable: PGM & multi-view	6x SDI Outputs assignable: AUX 1-4, PGM, PVW, PGM Clean & multi-view 2x HDMI	2x HD-SDI & 2x HDMI assignable: PGM(w/DSK 1&2), PGM(w/DSK 1),PGM Clean, PVW(w/o DSK), multi-view, Input 1-6	2x HD-SDI & 1x HDMI assignable: PGM(w/DSK),PGM Clean, PVW (w/o DSK),multi-view, Input 1-4 PVW+DSK1, Still, Freeze
Down-converted output	Yes, 2x SDI (CH2 & CH3)	N/A	N/A	N/A
Built-in Multi-view monitoring out	2x HDMI	2x HDMI	HDMI, SDI assignable & MPEG Streaming thru Ethernet	HDMI
Audio input	4x Balanced XLR	4x Balanced XLR	2x Balanced XLR	2x Balanced XLR
Audio output	2x Balanced XLR	2x Balanced XLR	N/A	N/A
Embedded audio support	Input up to 16 channels, Output 4 channels	Input up to 16 channels, Output 4 channels	embedded 2-CH audio output from XLR input	embedded 2-CH audio output from XLR input
Audio Delay Calibration	Up to 8 frames (* SDI input audio only)	N/A	N/A	N/A
A+V switching	Yes	Yes	N/A	N/A
Chroma key	N/A	N/A	2 Keyers	1
Title Creator	Yes	Yes	N/A	N/A
USK	N/A	N/A	2x USK support Chroma Key & Linear/ Luma Key	2x USK supports M/E Keyer & PIP
DSK	2x DSK support Lumakey & Linear key (Key/ Fill)	1x DSK support Lumakey & Linear key (Key / Fill)	2x DSK support Lumakey & Linear key (Key / Fill)	1
Picture in Picture	2	2	1	1
Logo Insertion	2 (or 1 logo + 1 clock)	2 (or 1 logo + 1 clock)	N/A	N/A
Still Store	12	6	1000+	1000+
Effects	FTB, Cut, 8 Wipe with border	FTB, Cut, 8 Wipe with border	FTB, Cut, 32 Wipe with border	FTB, Cut, 32 Wipe with border
Transition on Preview	PIP & DSK	PIP & DSK	Full transitions preview	Full transitions preview
Sync / Reference In/Out	Built-in Genlock . Support external sync with loop thru	Built-in Genlock	Built-in Genlock	Built-in Genlock
Tally Output	1x D-sub 25pin, dual color	1x D-sub 25pin, dual color	1x D-sub 15pin, dual color	1x D-sub 15pin, dual color
PC Remote Control	Via Ethernet or RS-422 / RS- 232	Via Ethernet or RS-422 / RS- 232	Via Ethernet or RS-232	Via Ethernet
Built-in Audio Mixer	N/A	N/A	N/A	N/A
Special Features	2-CH SD downconvert output Built in TC-200 CG system Selectable SMPTE/ EBU Audio level	6x 6 Matrix seamless switch, Built in TC-200CG interface	Motion JPEG Multi-view streaming (120 memory preset, BGD Transition on/off option)	12 Macro Memory Preset
Chassis	2 units, rack-mount mainframe	2 units, rack-mount mainframe	2 units, rack-mount mainframe	Unibody
Power	DC 12V 48W	DC 12V 32W	DC 12V 30W	DC 12V 23W
Accessory	CB-46/ 47/ 50 (30/ 50/ 100m)			

Model	SE-650	SE-500HD	SE-600	SE-500
				
Video Standard	HD	HD & SD	SD	SD
Video Format	1080i 50/59.94/60Hz 720p 50/59.94/60Hz	1080p 50/59.94/60Hz 1080i 50/59.94/60Hz 720p 50/59.94/60Hz 576i 50Hz 480i 59.94Hz	NTSC 480i 59.94Hz PAL 576i 50Hz	NTSC 480i 59.94Hz PAL 576i 50Hz
Video Processing	SDI: 4:2:2 HDMI: YUV 4:2:2 10 bit, RGB 4:4:4	HDMI: YUV 4:2:2 10 bit, RGB: 4:4:4		4:2:2
Input Routable / Crosspoint	All 4, repeatable	N/A	All 8, repeatable	Fixed
Video Input	2xHD-SDI 2xHDMI	4x HDMI	6x CV, 1x DVI-D (or HDMI) 1x DVI-I (or VGA)	4x CV or 4x Y/C
Mix HD & SD source	N/A	Yes	2 built-in down-converter on DVI-D & DVI-I input	N/A
Computer Graphic Interface	2 via HDMI	4 via HDMI	2 via DVI-D, HDMI or VGA	N/A
Video output	2 x HDMI (1 is MV, 1 is Assignable) 1 x HD-SDI (Assignable)	2 x HDMI (1 is MV, 1 is PGM)	2x CV + 1x Y/C or 1x CV + 1x YUV: PGM 2x CV: AUX 1 2x CV: AUX 2 2xDVI-D: multi-view Option: 2x DV & 2x SDI	2x CV & 1x Y/C or 1x CV & 1x YUV 1x CV Quad Preview
Down-converted output	N/A	N/A	N/A	N/A
Built-in Multi-view monitoring out	HDMI	HDMI	2x DVI-D	1x CV
Audio input	1 x Stereo RCA (L/R) 2 x Mono Microphone De-embedded Digital Audio (2 CH)	1 x Stereo RCA (L/R) 2 x Mono Microphone De-embedded Digital Audio (2 CH)	2x Balanced XLR (Line / Mic) 2x Unbalanced RCA (pair)	2x 1/4" Mic jack 2x Unbalanced RCA (pair)
Audio output	1 x Stereo RCA (L/R) 1 x Stereo headphone (Mini Jack with volume control) Embedded Digital Audio (2 CH / Channel 1 & 2)	1 x Stereo RCA (L/R) 1 x Stereo headphone (Mini Jack with volume control) Embedded Digital Audio (2 CH)	2x Balanced XLR 2x Unbalanced RCA (pair)	2x Unbalanced RCA (pair)
Embedded audio support	embedded 2-CH digital audio	embedded 2-CH digital audio	Output only (optional SDI & DV out)	N/A
Audio Delay Calibration	N/A	N/A	Up to 700ms / 17 frames	N/A
A+V switching	N/A	N/A	Yes	N/A
Chroma key	1 Keyers	N/A	N/A	N/A
Title Creator	N/A	N/A	N/A	N/A
USK	2x USK supports M/E Keyer & PIP	N/A	N/A	N/A
DSK	N/A	N/A	1x Lumakey	N/A
Picture in Picture	1	1	2	1
Logo Insertion	1	N/A	2	N/A
Still Store	1000+	N/A	2	N/A
Effects	FTB, Cut, 32 Wipe with border	FTB, Cut, Wipe with border	FTB, Cut, Mosaic, Paint, Monochrome, 14 Wipe with border	Quad, Split, 11 Wipe with border
Transition on Preview	Full transitions preview	N/A	Transition & Effect	Yes
Sync / Reference In/Out	Built-in Genlock	Built-in Genlock	Built-in Genlock	Built-in Genlock
Tally Output	1x D-sub 15pin, dual color	1x D-sub 15pin, dual color	2x D-sub 15pin, dual color	1x D-sub 15pin, dual color
PC Remote Control	Via Ethernet (free Window software)	N/A	Via RS-422	Via RS-232
Built-in Audio Mixer	4 channels	4 channels	3 channels	3 channels
Special Features			3 Macro Memory Preset	N/A
Chassis	Unibody	Unibody	Unibody	Unibody
Power	DC 12V 23W	DC 12V	DC 12V 33W	DC 12V 18W
Accessory	CB-46/ 47/ 50 (30/ 50/ 100m)			

4K Multi-Channel Unit KMU-100



Datavideo's multi-award winning KMU-100 is an affordable 4K multi-camera production solution that delivers multiple virtual full HD (up to 1080p) scaled camera angles with minimal installation cost and simple operation. The basic concept is straightforward: the output of one or two 4K/UHD cameras is connected to KMU-100, which then displays up to four 16x9 user-defined cropped windows that are sent out as four separate HD signals through 3G-SDI.

These user defined windows can be scaled to zoom in on a particular subject that you would like to highlight on the 4K signal. An additional 4K camera could be connected to allow up to eight HD outputs from the two 4K signals. As an option, a hardware panel with joystick controller can be added to easily pan, tilt, and zoom to create each HD window. You can set up these shots in advance and save them as presets, or you can do it in real-time.

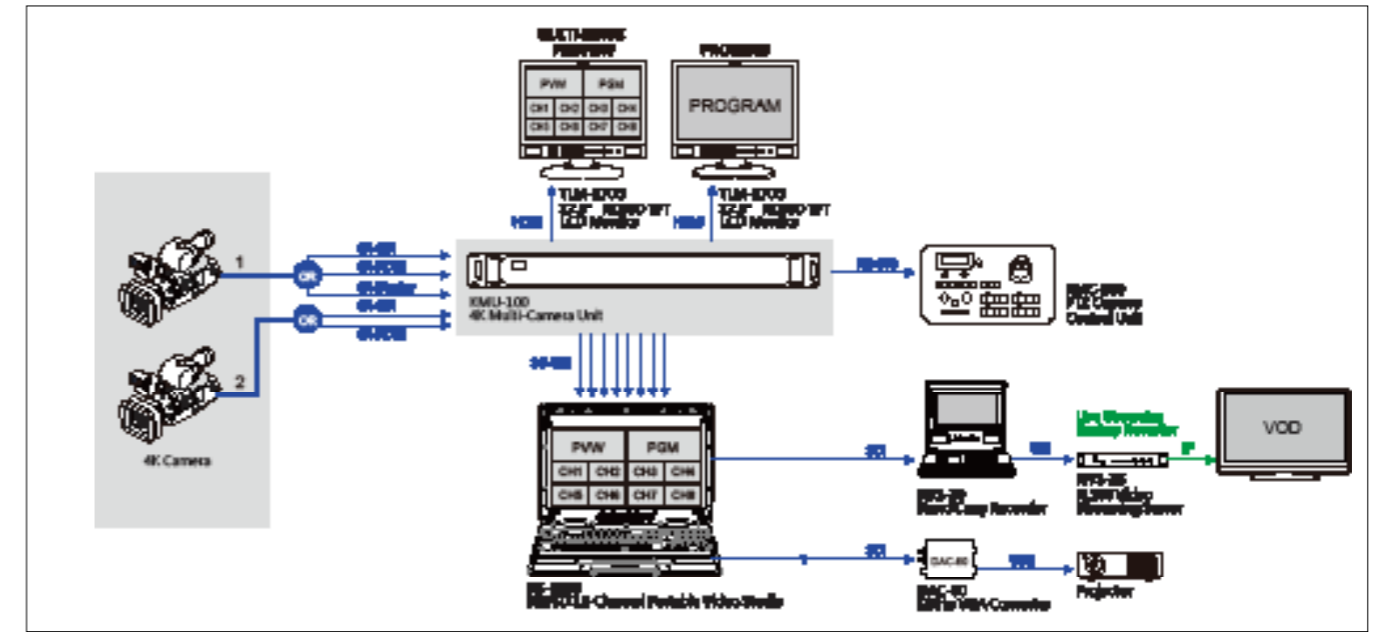

- Video Inputs
 - Quad SDI, 6G-SDI or 12G-SDI
 - HDMI 2.0 video input with support for 2160p60
 - DisplayPort video input with support for 2160p60
- SDI Video Outputs
 - 8 x 3G-SDI
- Monitoring
 - 2 x HDMI 1.4
- Audio
 - SDI Audio Input (16 Channels)
- SDI Audio Output (16 Channels)
 - Sync Input (Genlock)
 - Blackburst or TrinSync
 - Computer Interface
 - Ethernet RJ45 for control, configuration and updates (for laptop)
 - RS-232/ RS-422 x 1

Applications



Live Events
Turn your four or eight camera concert into a one or two 4K camera production with 8 unique angles. With the use of the RMC-180 you can pan your shot to the bass player, to a lead singer or zoom in on the drummer all with the scaling power of KMU-100. Impress your client by producing a high quality production on a small budget.



Worship
Small worship productions usually only need a few camera angles on stage; for example, a close up of the pastor, the choir, a shot of the chorister, and a wide shot of the stage. Now with KMU-100 you can get all those camera angles with just one 4K camera.



Broadcast
Setting up for a press conference has never been easier than with the KMU-100. Set up one camera and get multiple angles of those at the podium, conference table, and get a wide shot of the setting without a camera operator.



Video Commander
MTX-100/ 200



The MTX is a modular matrix switcher that incorporates multiple signal switching and monitoring. The unit is housed in a 2RU/3RU enclosure. It offers high-speed video and audio routing, flexible KVM switching, and multiviewing capabilities through various I/O card combinations.

The "Surfer" feature allows users to manage a variety of inputs and outputs across multiple monitors and seamlessly switch control to any of the system.

MTX's GUI enables the user to control switching and configure signal routing, as well as offering real-time monitoring of source/output. Additionally, users can remotely access all system menus directly on the GUI, for effective centralized administration solution.

Key Features

Modular Card-Based Design

- 2RU/3RU enclosure with hot-swappable I/O cards and field-serviceable fan modules
- 12x8 (MTX-100) / 20x16 (MTX-200) matrix architecture for video, embedded audio and mouse/keyboard switching
- Redundant power supply ensures mission-critical reliability (works with Avitech Power Supply Station)

Flexible I/O And Workstation Configuration

- Wide selection of I/O cards for multi-format signal routing, quad/dual multiview monitoring and KVM switching
- Auto-senses HDMI/DVI and SDI (3G/HD/SD) / CVBS (NTSC/PAL) source signals
- HDMI I/O cards are HDCP compliant with support of videos with 8-channel embedded audio
- Adaptive video equalization extends cabling distance up to 40m for 1080p/60 HDMI source signal with Deep Color
- Output cards provide mouse/keyboard connectivity for direct system control (up to 4 systems from a quad multiviewer card)

- Output grouping and "Surfer" empower streamlined workstation operation (control up to 16 systems across 4 screens via one set of mouse and keyboard)
- **Intuitive Control And System Administration**
- In-system GUI facilitates switching and configuring grouped workstation via a local monitor, USB mouse and keyboard ; no additional software required
- Real-time monitoring of any 2 images drag-and-drop to customizable preview/confirmation windows; enables remote control of source systems directly on the GUI
- Control Board (CB) provides local system connection allowing switch of operation between the GUI and local system
- Supports 100m HDBaseT extension for GUI/local system control at the remote administration station
- Front push-button panel provides an alternate switching/ routing control



MTX-100



MTX-200



4.3" Look-Back Monitor
TLM-430



Lookback monitor with tally light
Datavideo TLM-430 4.3" look-back monitor with built-in tally lamp enables the cameraman to monitor the video program in real time. The lightweight design (less than 210 grams) makes it easy to handle.

7" HD/SD TFT LCD Monitor
TLM-700HD



The Datavideo TLM-700HD features a standard V-Mount enabling you to power the monitor using a standard battery from a range of manufacturers. Perfect for use in the field.

Model	Description
TLM-700HD-C	TLM-700H w/ Canon Battery Mount (compatible with Canon BP series DV batteries)
TLM-700HD-A	TLM-700H w/ Anton Bauer Battery Mount (Gold mount plate with a 14.4V D-tap output socket for Gold mount battery applicable)
TLM-700HD-P	TLM-700H w/ Panasonic Battery Mount (compatible with Panasonic CGA series DV batteries.)
TLM-700HD-S1	TLM-700H w/ Sony Battery Mount (S-7000U) (for SONY EX1 / EX3 camcorder's battery/ compatible with SONY BP-U60, BP-U30 DV batteries)
TLM-700HD-S2	TLM-700H w/ Sony Battery Mount (S-7000F) (e.g For SONY Z5 camcorder's battery/ compatible with SONY NP-F770/970/960/950 DV battery applicable)

Model	TLM-170P/PM/PR	TLM-170G/GM/GR	TLM-702HD
Screen	17.3" LED Back-Lit	17.3" LED Back-Lit	2x7" LED Back-Lit
Chassis	Tabletop (170P) 1RU Pull-Out (170PM) 7RU Rack Mount (170PR)	Tabletop (170G) 1RU Pull-Out (170GM) 7RU Rack Mount (170GR)	3RU Rack Mount
Panel Resolution	1920x1080	1920x1080	800x480
Viewing Angle	(H) +80/-80° (V) +60/-80°	(H) +70/-75° (V) +60/-60°	(H) +70/-70° (V) +50/-70°
Luminance/Contrast	400cd/m² 600:1	300cd/m² 400:1	300cd/m² 500:1
Video Inputs	1x 3G/HD/SD-SDI 2x HDMI 1x HD/SD-YUV 2x Composite Video	1x 3G/HD/SD-SDI 2x HDMI	2x HD/SD-SDI 2x HD/SD-YUV 2x HDMI 2x Composite Video
Loop Through	1x 3G/HD/SD-SDI 1x Composite Video	1x 3G/HD/SD-SDI	N/A
Supported Input Resolutions	1080p(23.98/24/25/30/50/59.95/60Hz), 1080i(50/59.94/60Hz), 720p(50/59.94/60Hz), 480i (NTSC), 576i (PAL)	1080p(23.98/24SF/24/25/29.97/30/50/59.95/60Hz), 1080i(50/59.94/60Hz), 720p(50/59.94/60Hz), 480i (NTSC), 576i(PAL)	1080i(50/60Hz), 720p(50/60Hz) 480i(NTSC), 576i(PAL)
Aspect Ratio	16:9, 4:3	16:9, 4:3	16:9, 15:9, 4:3
Tally LED	Live (Red) Cued (Green)	Live (Red) Cued (Green)	Live (Red) Cued (Amber)
Audio In/Out	Embedded Audio on SDI and HDMI 3 x Mono RCA Inputs Stereo Speakers	Embedded Audio on SDI and HDMI	Embedded Audio on SDI and HDMI Audio Level Indicator 2x Stereo Headphone Jack
Special Features	3G-SDI Support, Picture-in-Picture, Blue Only, Audio Level Indicator, Safe Frame, Pixel Zoom up to 8x, Network IP Remote, SDI Time Code Display	3G-SDI Support, Blue Only, Safe Frame, Pixel Zoom up to 8x	Blue Only, Safe Frame, SDI Time Code Display, Audio Level Indicator, Safe Frame
Power	DC 12V, 30 watts	DC 12V, 18 watts	DC 12V, 30 watts

Model	TLM-700HD	TLM-434H	TLM-430
Screen	7" LED Back-Lit	4x4.3" TFT LCD	4.3" TFT LCD
Chassis	Camera Mount	2RU Rack Mount	Camera Mount
Panel Resolution	800x480	480x272	480x272
Viewing Angle	(H) +70/-70° (V) +50/-70°	(H) +80/-80° (V) +80/-80°	(H) +70/-70° (V) +50/-70°
Luminance/Contrast	300cd/m² 500:1	320cd/m² 400:1	500cd/m² 500:1
Video Inputs	1x HD/SD-SDI 1x HD/SD-YUV 1x HDMI 1x Composite Video	4x HD/SD-SDI 4x HDMI	2x Composite Video
Loop Through	N/A	4x HD/SD-SDI	N/A
Supported Input Resolutions	1080i(50/60Hz) 720p(50/60 Hz) 480i(NTSC) 576i(PAL)	1080i(50/60Hz) 720p(50/60 Hz) 480i(NTSC) 576i(PAL)	480i(NTSC) 576i(PAL)
Aspect Ratio	16:9, 15:9, 4:3	16:9, 4:3	16:9, 4:3
Tally LED	Live (Red) Cued (Amber)	Live (Red) Cued (Amber)	Live (Red) Cued (Green)
Audio In/Out	Embedded Audio on SDI and HDMI Audio Level Indicator, 1x Stereo Headphone Jack	Embedded Audio on SDI and HDMI, Audio Level Indicator, 4x Stereo Headphone Jack	N/A
Special Features	Blue Only, Safe Frame, SDI Time Code Display, Audio Level Indicator, Safe Frame, Image Flip, Can powered by batteries (Not Included)	Blue Only, Embedded Time Code Indicator, Safe Frame	Can be powered by DC adaptor, Sony batteries or D-TAP. TLM-43LB Camera look back system (with RMC-200 and control cable)
Power	DC 12V, 18 watts	DC 12V, 15 watts	DC 12V, 6 watts

Up/ Down/ Cross Converter

DAC-70

Datavideo DAC series has a rugged metal housing for use in even the roughest conditions. DAC-70 is our most popular and versatile converter.

DAC-70 up/down/cross converter is designed to convert video signals from VGA, HDMI, SDI with Audio input to 3G/HD/SD SDI outputs.

Perfect for connecting a VGA/HDMI output from computer to SDI devices over long distance SDI cable.



DAC-70 Product Video



Input		Output	
3G-SDI/ HDMI	1080p 60 / 50	VGA/ HDMI	800x600@60Hz
	1080p 59.94		1024x768@60Hz
HD-SDI/ HDMI	1080p 30 / 25 / 24		1280x1024@60Hz
	1080p 29.97		1366x768@60Hz
	1080p23.98		1400x1050@60Hz
	1080i 60 / 50		1600x1200@60Hz
	1080i 59.94		
	720p 60 / 50		
SD-SDI/ HDMI	720p 59.94		
	NTSC(525i)		
	PAL(625i)		

Up/Down/Cross

Model	DAC-70	DAC-60	DAC-50S
Conversion	VGA/HDMI/SDI to HDMI/SDI Multi-format Up/Down/Cross	3G/HD/SD-SDI to VGA	3G/HD/SD-SDI to Analog Down Converter
Video Inputs	Sel.: 1x VGA, 1x HDMI, 1x 3G/HD/SD-SDI	1x 3G/HD/SD-SDI	1x 3G/HD/SD-SDI
Loop Through	Yes	Yes	Yes
Video Outputs	2x 3G/HD/SD-SDI with embedded Audio	1x VGA	YUV + Composite or Y/C + 2x Composite
Audio Inputs	2x RCA (Stereo Pair), 2x HDMI Audio embedded	2x SDI Audio embedded	2x SDI Audio embedded
Audio Outputs	External 2-CH unbalanced Audio input or 8-CH from embedded Audio input	N/A	2x RCA (Stereo Pair)
Supported Video Input Format	800x600 (60Hz), 1024x768(60Hz), 1280x1024(60Hz), 1366x768(60Hz), 1400x1050(60Hz), 1600x1200(60Hz), 480i (NTSC), 576i (PAL), 1080p (23.98/24/25/29.97/ 30/50/59.94/60Hz), 1080i (50/59.94/60Hz)	480i (NTSC), 576i (PAL), 720p (50/59.94/60Hz), 1080i (50/59.94/60Hz), 1080p (23.98/24/25/29.97/ 30/50/59.94/60Hz)	720p (50/59.94Hz), 1080i(50/59.94Hz), 1080p(50/59.94Hz), 480i, 576i
Output Resolutions	480i, 576i, 720p (50/59.94/60Hz) 1080i (50/59.94/60Hz) 1080p (23.98/24/25/29.97/30/50/59.94/60Hz)	800x600 (60Hz), 1024x768 (60Hz), 1280x800 (60Hz), 1280x1024 (60Hz), 1366x768 (60Hz), 1400x1050 (60Hz), 1600x1200 (60Hz), 1920x1080 (60Hz), 1920x1200 (60Hz)	480i, 576i
Equalizer	Yes	N/A	Yes
Reclock	Yes	Yes	N/A
SDI Cable Drive	Yes	Yes	N/A
Power	DC 12V, 6 watts	DC 12V, 3.6 watts	DC 12V, 6.0 watts
Remarks	- Heavy duty design, robust metal casing - Low power consumption (30 ~ 50% less than regular converters) - Low heat dissipation, ideal for long hour operation in normal ventilated environment - Supports wide range of 3G video formats including 1080p 50/59.94/60Hz (DAC-8P/9P/50S/60/70) - Supports YUV and RGB color space (DAC-8P/9P/70) - Can be rackmounted using optional RMK-2 2RU Rackmount Kit - Can be used with DAC accessories: MB-4 DAC Series Battery Holder, and MB-5 DAC Series Tripod Mount		

2RU Rackmount Kit

RMK-2

- Rackmount Frame to hold up to 8 DAC Converters
- Built in power distributor for up to 8 converters
- Suitable for all Datavideo converters, distributors or other peripherals using the same housing



RMK-2 Product Video



DAC Series Battery Holder

MB-4



DAC Series Tripod Mount

MB-5



VS-100 Battery Mount Kit

MB-6



Battery Model	SONY NP-F970	SONY NP-F770	SONY BP-U60	SONY BP-U30	Panasonic CGA-D540	Canon BP-975	JVC BN-VF823
	7.2V / 5400mAh	7.2V / 3000mAh	14.4V / 5200mAh	14.4V / 2600mAh	7.2V / 5400mAh	7.4V / 7350mAh	7.2V / 2190mAh
DAC-7	12W 190min	100min	190min	180min	190min	270min	70min
DAC-8P	4W 580min	320min	1120min	560min	580min	815min	230min
DAC-9P	5W 460min	250min	890min	440min	460min	650min	180min
DAC-50S	18W 120min	70min	240min	120min	120min	180min	50min
DAC-60	6W 380min	210min	740min	370min	385min	540min	150min
DAC-70	7.2W 320min	180min	620min	310min	320min	450min	130min
VS-100	3.6W 640min	360min	1240min	620min	640min	900min	380min

Model	DAC-9P	DAC-8P	DAC-7
Conversion	HDMI to 3G/HD/SD-SDI	3G/ HD/SD-SDI to HDMI	SD Analog to SD-SDI
Video Inputs	1x HDMI	1x 3G/HD/SD-SDI	Sel.: 1x CV, 1x YUV, 1x S-Video
Loop Through	N/A	Yes	N/A
Video Outputs	2x 3G/HD/SD-SDI with embedded Audio	1x HDMI with embedded Audio	2x SD-SDI with embedded Audio
Audio Inputs	2x HDMI Audio embedded	2x RCA (Stereo Pair) 2x SDI Audio embedded	2x RCA (Stereo Pair) 2x XLR (Stereo Pair)
Audio Outputs	2x SDI Audio embedded	2x HDMI Audio embedded	2x SDI Audio embedded
Supported Video Input Format	480i (NTSC), 576i (PAL), 720p (50/59.94/60Hz), 1080i (50/59.94/60Hz), 1080p (23.98/24/25/29.97/ 30/50/59.94/60Hz)	480i (NTSC), 576i (PAL), 720p (50/59.94/60Hz), 1080i (50/59.94/60Hz), 1080p (23.98/24/25/29.97/ 30/50/59.94/60Hz)	480i(NTSC), 576i(PAL)
Output Resolutions	Automatically matches the SD, HD and 3G HDMI video input	Automatically matches the SD, HD and 3G SDI video input	Automatically matches the NTSC, PAL video input
Equalizer	N/A	Yes	N/A
Reclock	N/A	Yes	N/A
SDI Cable Drive	Yes	Yes	Yes
Power	DC 12V, 5 watts	DC 12V, 4 watts	DC 12V, 2.4 watts
Remarks	- Heavy duty design, robust metal casing - Low power consumption (30 ~ 50% less than regular converters) - Low heat dissipation, ideal for long hour operation in normal ventilated environment - Support wide range of 3G video formats including 1080p 50/59.94/60Hz (DAC-8P/9P/50S/60/70) - Support YUV and RGB color space (DAC-8P/9P/70) - Can be rackmounted using optional RMK-2 2RU Rackmount Kit - Can be used with DAC accessories: MB-4 DAC Series Battery Holder, and MB-5 DAC Series Tripod Mount		

Fieldside Hand Carry Recorder HRS-30



HRS-30 is a portable recording and playback system which provides instant preview of recorded footage, mark points during live recording, highlight clips to replay in slow motion and batch playback of all marked highlight clips in the same folder.

Model	HRS-30	HDR-60/ 70
Product Name	Fieldside Hand Carry Recorder	HD/SD Digital Video Recorder
Video Standard	HD & SD	HD & SD
Video Format	1080p 23.97/24Hz, 1080i 50/59.94/60Hz, 720p 50/59.94/60Hz, 576i 50Hz, 480i 59.94Hz	1080P 23.97/24Hz, 1080i 50/59.94/60Hz, 720P 50/59.94/60Hz, 567i 50Hz, 480i 59.94Hz
Supported Video Input Signal	1x SDI	1x SDI
Monitoring/ Playback output	1x SDI (input loop thru), 1x HDMI, 1x SDI (Out)	1x SDI (input loop thru), 1x HDMI, 1x SDI (Out)
Analog Audio Input & Audio Output	N/A (input), 3.5Ø phone jack (output)	2x Balanced mini XLR (Stereo pair)
Embedded Audio	SDI Input / Output (8CH), HDMI Output (8CH)	Both In & Out (8-CH on SDI & HDMI)
Storage Medium	SSD: 120GB / 256GB / 512GB	2.5" Hard Drive / SSD*, Max capacity 750GB
Estimated Record Time (min per 10GB)	SD: 22 (50Mbps) ~ 75 (8Mbps), HD: 10 (125Mbps) ~ 68 (10Mbps)	SD: 19 (50Mbps) ~ 70 (8Mbps), HD: 8 (125Mbps) ~ 62 (10Mbps)
How to Retrieve Recorded Content	Removable Hard Drive / SSD	Removable Hard Drive / SSD, transfer data via USB2.0
Storage File System	NTFS	NTFS (read only)
Recorded File Format	MXF OP1A, MOV	MXF OP1A, MOV
Video Recording Bit Rate/ Color Sampling	MPEG2 Long GOP HD: 1. 10Mbps 4:2:0 1440x1080/1280x720, 2. 25Mbps 4:2:0 1440x1080/1280x720, 3. 35Mbps 4:2:2 1920x1080/1280x720, 4. 50Mbps 4:2:2 1920x1080/1280x720, 5. 65Mbps 4:2:2 1920x1080/1280x720, 6. 120Mbps 4:2:2 1920x1080/1280x720, MPEG2 Long GOP SD 1. 8Mbps 4:2:0 720x480/720x576 (to be F/W upgrade), 2. 15Mbps 4:2:2 720x480/720x576, 3. 30Mbps 4:2:2 720x480/720x576, 4. 50Mbps 4:2:2 720x480/720x576 MPEG2 I-Frame Only HD 1. 80Mbps 4:2:2 1920x1080/1280x720 2. 100Mbps 4:2:2 1920x1080/1280x720 3. 125Mbps 4:2:2 1920x1080/1280x720 MPEG2 I-Frame Only SD 1. 25Mbps 4:2:2 720x480/720x576 2. 50Mbps 4:2:2 720x480/720x576	MPEG2 Long GOP HD: 1. 10Mbps 4:2:0 1440x1080/1280x720, 2. 25Mbps 4:2:0 1440x1080/1280x720, 3. 35Mbps 4:2:2 1920x1080/1280x720, 4. 50Mbps 4:2:2 1920x1080/1280x720, 5. 65Mbps 4:2:2 1920x1080/1280x720, 6. 120Mbps 4:2:2 1920x1080/1280x720, MPEG2 Long GOP SD 1. 8Mbps 4:2:0 720x480/720x576 (to be F/W upgrade), 2. 15Mbps 4:2:2 720x480/720x576, 3. 30Mbps 4:2:2 720x480/720x576, 4. 50Mbps 4:2:2 720x480/720x576 MPEG2 I-Frame Only HD 1. 80Mbps 4:2:2 1920x1080/1280x720 2. 100Mbps 4:2:2 1920x1080/1280x720 3. 125Mbps 4:2:2 1920x1080/1280x720 MPEG2 I-Frame Only SD 1. 25Mbps 4:2:2 720x480/720x576 2. 50Mbps 4:2:2 720x480/720x576
Audio Recording Format	Uncompressed PCM	Uncompressed PCM Sampling rate 48KHz 24bit
Time code in/out	Yes	Yes
External Sync/Genlock	Black Burst & Tri-level w/loop thru	Black Burst & Tri-level with loop thru
Power Failure Protection	Content saved up to last second before power failure	Content saved up to last second before power failure
Chassis	Desktop	Desktop (HDR-60) 1RU 19" rack-mountable (HDR-70)

Highlight Replay Recorder HDR-10

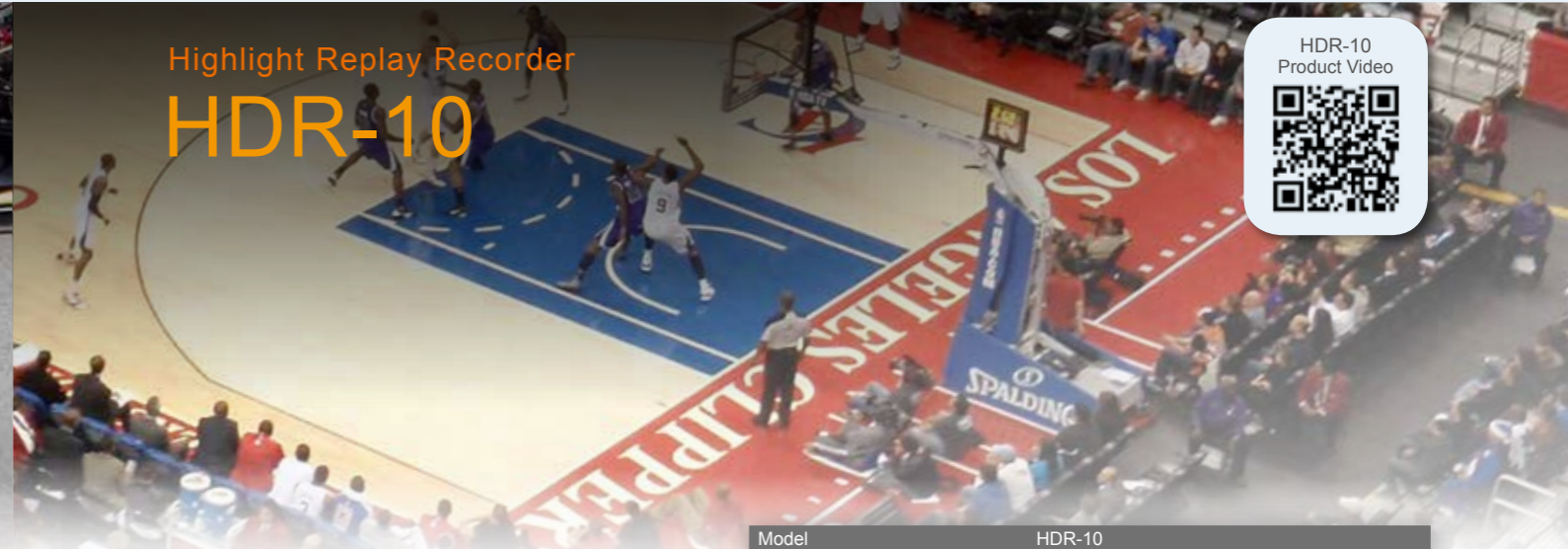

Model	HDR-10
Product Name	Highlight Replay Recorder
Video Standard	HD
Video Format	720p 50/59.94/60, 1080i 50/59.94/60, 1080p 50/59.94/60
Supported Video Input Signal	1xSDI
Monitoring/ Playback output	2xSDI
Analog Audio Input & Audio Output	N/A
Embedded Audio	SDI Input
Storage Medium	Internal 4GB Buffer
Estimated Record Time (min per 10GB)	N/A
How to Retrieve Recorded Content	Removable Hard Drive / SSD
Storage File System	NTFS (read only)
Recorded File Format	MOV
Video Recording Bit Rate/ Color Sampling	Uncompressed 10-bit 4:2:2
Audio Recording Format	Uncompressed PCM
Time code in/out	Via embeded SDI only
External Sync/Genlock	LISN (Local Interconnect Synchronous Network)
Power failure protection	N/A
Chassis	Rack-mountable with RMK-2 2U Rackmount Kit

Replay Control Center RMC-400



Adding instant replay to any sports productions has never been this easy. The cost-effective workflow of Datavideo's HDR-10 highlight replay unit combined with a brand new RMC-400 controller makes instant replay an option for all level of production.

The RMC-400 can control up to four HDR-10 highlight replay units, allowing you to have instant replay with slow motion and up to four different camera angles. Easily mark your in and out points using the jog shuttle dial to create a highlight clip, then press one button to replay. You can use the T-bar to control the speed. As you can connect multiple HDR-10s to the RMC-400, you can start off with 1-2 cameras and expand to 4 cameras for larger productions.

- Control up to 4 HDR-10 replay units at the same time through USB
- Short-cut keys to allow mark-in/out points and save clips
- T-bar allows speed of replay
- Jog wheel allows you to find in and out points of the replay
- Support GPI

Portable CG Solution

HD / SD Character Generator Kit

TC-200+CG-200

The combination of the TC-200 overlay unit and CG-200 brings broadcast-quality live titling to the laptop. Users can now create beautiful motion graphics in real-time without the need for a dedicated workstation - it's a significant breakthrough.

- Includes TC-200 (Title Creator) & CG-200 (Character Generator Software)
- Supports DSK function (via HDMI) or SDI overlay function
- Support HD/SD SDI input and output in Overlay mode
- Supports HD video with 1080i 50/59.94/60; 720p 50/59.94/60
- Compatible with Windows 7/8
- Supports all Windows fonts
- Multi-language support
- Supports animation including JPG, TAG, GIF, BMP, PNG
- Title editing patterns include Slide, Reveal, etc.
- Supports scrolling



- Easy logo set up
- TC-200 working voltage is 7-15V. It can be used with 7.2 V & 14.4 V batteries

HD/SD Graphic & Character Generator

CG-500

The Windows based Datavideo CG-500 graphics, titling, and character generator software is a powerful multi-layer, real-time solution for live programming and post production. It is compatible with widely available professional video hardware and supports the flexible play-out of multiple playlists, or Datavideo's TC-200 device while titles are being created. CG-500 can be used for SD or HD news, reports, weather forecasts, and entertainment programming. Hundreds of key frame based GPU effects, such as Swirl, Explode, and Linear Light can be rendered in real-time. The software features innovative group and text playing by character, by line, and by text, with fully dynamic textures.

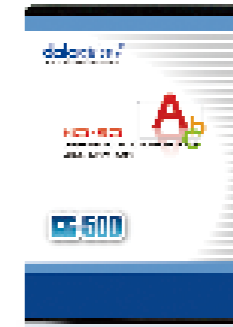

Applications

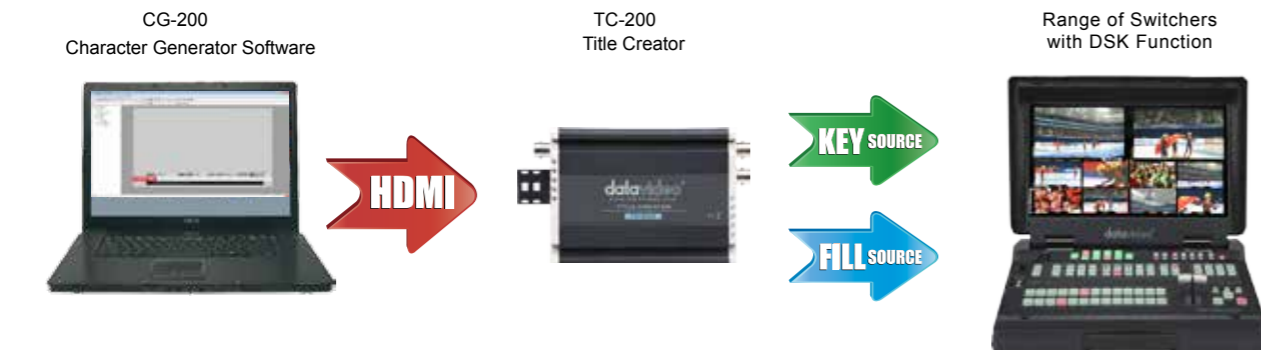

CG-250 (Optional)

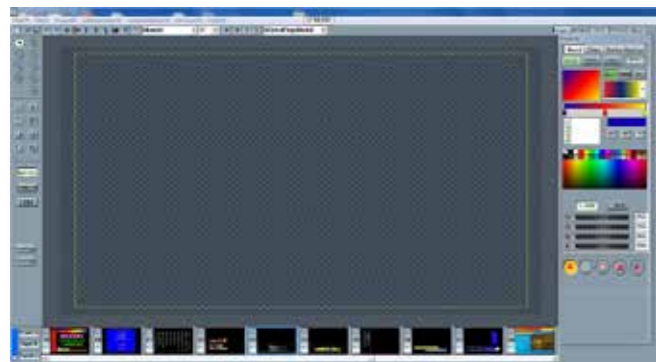

Special Features of CG-250

- A variety of CG templates and text font choices
- Supports Live 3D graphic
- Key frame control
- Supports countdown clock and sport scoreboard

CG-200 Example



CG-250 Example



Model	CG-500	CG-350	CG-250	CG-200
SD resolution	•	•	•	•
HD resolution	•	•	•	•
Manual playout control	•	•	•	•
Playlists	•	•	•	•
Animated logo / sequence	•	•	•	•
Scheduling	•	•	•	•
Dynamic Data integration	•	•	•	•
Database integration	•	•	•	•
Live 3D graphics	•	•	•	•
Fast graphics rendering	•	•	•	•
Template-based	•	•	•	•
Media library	•	•	•	•
Keyframe control	•	•	•	•
Capture Video Frame	•	•	•	•
Recommended Video Card for both Internal/External key	Datavideo TC-200 Decklink 4K Extreme	Datavideo TC-200 Decklink 4K Extreme	Datavideo TC-200	Datavideo TC-200

HD/SD-SDI PTZ Camera
**PTC-150T/
 PTC-150TW**



The PTC-150T HD/SD Video Camera is a PTZ camera that is equipped with HDBaseT Technology. HDBaseT delivers video signals, tally, camera control and power over a single Ethernet connection, making installations very fast and very easy. The camera captures HD video at 1920 x 1080 resolution, and features wide dynamic range with backlight compensation. PTC-150T has a receiver box that allows the user to control the camera at a remote location with just one Ethernet cable. The camera supports Sony VISCA protocol for PTZ control using RS-422 interface over the unit's RJ-45 port.

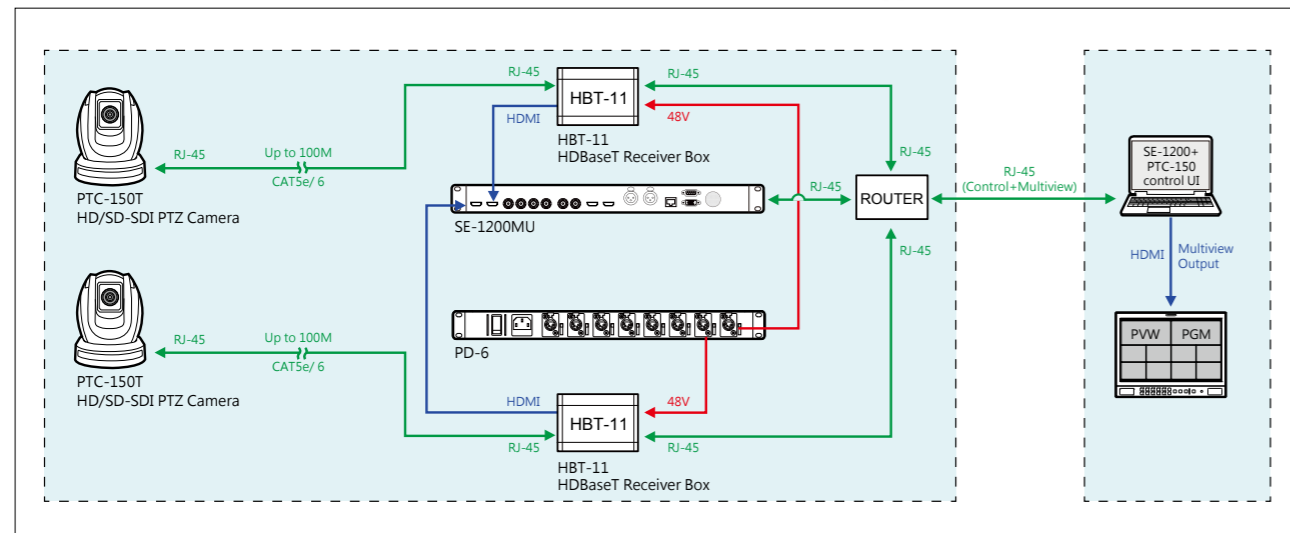

HBT-11 HDBaseT Receiver Box



HBT-11 HDBaseT Receiver Box is equipped with HDBaseT Port, which connect PTC-150T Camera HDBaseT Port by using a CAT5e/6 Cable. This allows user to transmit video source, control single and power just by using CAT5e/6 Cable that can be transmit up to 100m.

HD/SD-SDI PTZ Camera
**PTC-150/
 PTC-150W**



PTC-150 is ideal for AV production, automated TV studios, fixed rig production, lecture recording, conference and meetings and houses of worship. Its unique position tracking function is able to output frame accurate PTZ positions in real time. With a large tally light, 3G 1080p50/60 resolution, and 2m Pixels, PTC-150 can satisfy applications that require high image quality. Our innovative removable lens on the PTZ camera allows the user to use 52-mm filter lenses or wide angle lenses in order to suit every type of production.

PTZ Camera Control Unit
RMC-180

1-4 Camera Control



Maximum Camera Control	4
Present Position	4 for each camera
Control Protocol	Sony VISCA
Connection to Cameras	Point to Point

Model	PTC-150T	PTC-150TW	PTC-150	PTC-150W
Video format	1080p 59.94/50/29.97/25 Hz 1080i 59.94/50 Hz 720p 59.94/50 Hz 480i, 576i (on CVBS)			
Image Sensor	1/2.8" type progressive scan CMOS sensor			
Effective Pixels (approx.)	2.14 Mega pixels			
Min. Illumination	Color : 0.4 lx B/W : 0.03 lx (F1.6, 1/30 sec, 50IRE, Gain: High)			
Electronic Shutter	1/50 (1/60), 1/120 (1/100), 1/250, 1/500, 1/1000 sec			
Zoom Ratio	30x Optical zoom			
Gamma Control	Off / Normal / Standard Mode 1-4			
Iris Control	Auto / Manual			
Digital Noise Reductions	Yes			
White Balance	AWB / MWB / One push WB / Outdoor / Indoor / Fluorescent			
AGC / Gain Control	Auto / Manual Max. Gain Limit			
Mirror / Flip Image	Yes			
Focus Mode	Auto / Manual			
Panning/Tilting Range	Pan: 270° , Tilt: +90° to -20°			
Panning/Tilting Speed	Manual: 1~150°/Sec Swing: 1~150°/Sec			
Preset	50 Position			
Field of View (Horizontal, Wide)	Approx. 63.7 degrees (WIDE END) / 2.3 degrees (TELE END)			
Image Compensation	Day & Night function			
Video Output	3G-SDI x 1, HDMI x 1, CVBS x 1, HDBaseT x 1 to PTC-150T Receiver Box		3G-SDI x 1, HDMI x 1, CVBS x 1	
Tally LED	Dual color (Red, Green)			
Filter	Yes			
Remote Control Interface	RS-422, HDBaseT (RJ-45) ; DVIP on Reciver Box		RS-422, DVIP (RJ45)	
Camera Control Unit color	dark blue	white	dark blue	white

HDBaseT Receiver Box
HBT-11



HDBaseT Transmitter Box
HBT-10



The HBT-10 and HBT-11 HDBaseT transmitter and receiver provide a maximum transmission distance of 100 meters. The pair supports video transmission up to 4K resolutions over Ethernet. With a 48V power source connected to one end of the HBT-11 HDBaseT receiver, the HBT-11 can also remotely power the transmitter using Power over Ethernet (PoE).

On the transmitter end, there is also a 12V/30W DC output serving to supply power to external devices. DVIP control can be achieved over the same Ethernet cable. In other words, HDMI video, DVIP control signals and Power over Ethernet (PoE) can be transmitted between the transmitter and the receiver using a single Ethernet cable.

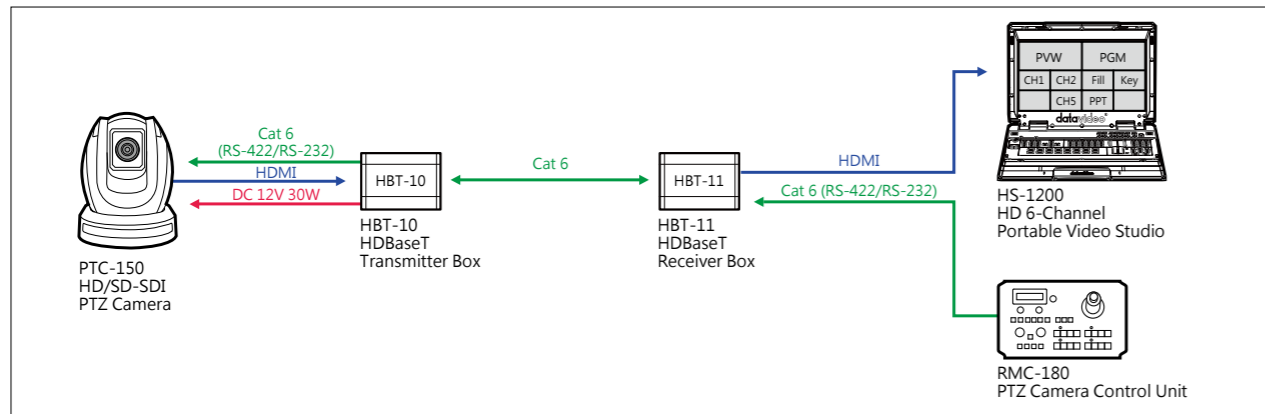

- Transmit up to 4K video from HBT-10 Transmitter Box to HBT-11 Receiver Box
- Extend video transmission up to 100m from HBT-10 Transmitter Box to HBT-11 Receiver Box
- Transmit video, audio, DVIP Ethernet control, RS-422/232 and POE by a single Cat.5e/6/6a/7 cable
- POE Power supply 48V input from HBT-11 Receiver side.
- 12V 30W DC output at HBT-10 Transmitter Box side
- Supports DVIP Control Protocol
- Supports RS-422/232 Control Protocol

Model Name	HBT-10	HBT-11
Product Name	HDBaseT Transmitter Box	HDBaseT Receiver Box
Video/Audio Input	HDMI x1	HDBaseT RJ-45 x1
Video/Audio Output	HDBaseT RJ-45 x1	HDMI x1
DVIP Ethernet	RJ-45 x1	
RS-422/ RS-232	Phoenix terminal. Pitch 3.50mm	
Power	DC OUT: DC 12V	DC IN: DC 48V
Dimension	131.8x85x45.2mm	
HDBaseT Distance	Up to 100m by Cat.6 cable	

Multi-camera Control Unit

MCU-100P for Panasonic
MCU-100S for Sony
MCU-100J for JVC

MCU-100 and MCU-200 are designed to control up to four camcorders in studio multi-camera configuration, giving the producer the ability to match and manage the settings of multiple cameras.



Model	MCU-100P/200P	MCU-100S/200S	MCU-100J/200J
Support functions	Record and Playback Camera User memory functions Camera OSD Menu Navigation Shutter speed and degree functions Iris adjustment AWB & ABB functions White Balance A, B and Preset functions Camera Knee & Bars functions Camera Gain adjustment RGB / R & B gain and Master Pedestal controls	Record and Playback Camera User memory functions Camera OSD Menu Navigation Shutter adjustment Iris adjustment AWB & ABB functions White Balance A, B and Preset functions Knee & Bars functions Gain adjustment RGB / R & B gain and Master Pedestal controls	Record and Record Review Control of Camera User memory Control of Shutter / Focus / Zoom function Iris adjustment AWB & ABB functions White Balance A, B and Preset functions Knee & Bars functions Camera Gain adjustment Assign function RGB / R & B gain and Master Pedestal controls
Camera side adapter	AD-1P	AD-1S	AD-1J
Camera controlled Qty	4	4	4
CAM remote interface	10 Pin remote connector	8 Pin remote connector	PS/2 Multicore & LANC
Composition monitoring to view the camera's own LCD/OSD menus	YES	YES	N/A
Compatible Camera Models	AG-HPX255, AG-HPX300, AG-HPX301, AG-HPX302, AG-HPX304, AG-HPX370, AG-HPX371, AG-HPX372, AG-HPX500, AG-HPX502, AG-HPX600, AJ-PX800G, AJ-HDX900, AJ-HPX2700G, AJ-HPX3000	PMW EX3, PMW 300K2, PMW 350K, PMW F5, PDW-510, HDW-F900R, PMW 300K1, PMW EX350, PDW-F55, PMW 400, PMW-320, PMW-400K, PMW-510, PXW-X320	GY-HM890U (LANC / PS/2), GY-HM850U (LANC / PS/2), GY-HM650U(LANC), GY-HM600U(LANC), GY-LS300CHU (LANC), GY-HM200U (LANC)
Connection Distance	300M	300M	300M

Multi-camera Control Unit

MCU-200P/200S/200J



We also provide multi-camera control unit in rack mount style.

Camera Remote Adaptor

AD-1P/1S/1J (4 units included)

Connecting the MCU-100P/100S/200P/200S
Connect AD-1 adaptor to the camera's camera remote port. Connect an ethernet cable from the AD-1 to the MCU. Parameters can viewed by connecting monitors to each AD-1 adaptor using a CVBS cable. MCU-100 and MCU-200 utilize locking power connectors.



Iris/Shutter Control Box

RMC-230

In multi-angle shoots with quickly changing lighting, the RMC-230 allows the director to manage the iris and shutter settings of multiple cameras.

Iris adjustment using a T-Bar is very fast and accurate - it is far more effective than buttons, sliders and knobs. RMC-230 connects to a MCU-100/200 master control unit, to give only an enhanced way of operating the MCU.

*RMC-230 only works on Sony



DV Prompter
TP-600



Protective Cases



HC-600

HC-500



The dv prompter application is available to download Free from Apple™ App Store™ & Google Play.



Wireless Controller - WR-500

The wireless version uses Bluetooth technology and can be charged over USB. It can also be tethered to a device via a USB cable.

Model	TP-150	TP-300	TP-500	TP-600
Product Name	Prompter kit for PTZ camera	Tablet Prompter (HD/SD Camcorders used)	DSLR Prompter	ENG Prompter
Device Used	Apple iPads Android Tablets	Apple iPads Android Tablets	Apple iPads Android Tablets	Apple iPads Android Tablets
Camera-Mount Interface	PTZ Prompter Frame	Prompter Frame	Adjustable Camera Plate	Prompter Rail
Smartphone/ Tablet Size	Min. Tablet Width: 145mm Max. Tablet Width: 265mm	Min. Tablet Width: 110mm Max. Tablet Width: 220mm	Min. Tablet Width: 110mm Max. Tablet Width: 220mm	Min. Tablet Width: 110mm Max. Tablet Width: 220mm
Multi-language support	Device dependent including Arabic and Asian languages such as Chinese, Japanese, Korean, Hindi, Tamil and more			
Hood Dimension/ Prompter Size	Not applicable - No hood supplied Below lens prompting only	Width: 250mm Height: 160mm Depth: 240mm	Width: 265mm Height: 160mm Depth: 120mm	Width: 415mm Height: 210mm Depth: 300mm
Remote Control	Wired Remote (inclusive) with headset jack input for Apple iOS devices and some Android devices *Optional Universal Bluetooth Wireless Remote (with USB cable adapter for charging purposes)			
Net Weight	0.78 Kg	1.82 Kg	1.28 Kg	3.28 Kg

DV Prompter Pro Wireless Prompting System
DVP-100



DVP-100 is a wireless teleprompting system designed to centrally control prompter screens. The DV Prompter Pro server creates its own WiFi hotspot ready for you to connect multiple screens, tablets and computers devices and start prompting. Once connected, you simply need to select if the device is to be a controller or a prompter screen. Up to 6 devices can be connected to the server simultaneously. The controller can create and load new scripts, control the scrolling and perform live edits on all prompter screens in real time. All scripts and settings are stored on the dvPrompter server not the devices themselves.

- Multiple prompter screens kept in perfect sync
- Remote control & script management over WiFi
- IOS App available
- Compatible with any device that has a HTML5 compliant web browser
- Embedded rich text editor
- Perform live edits
- Control multiple prompters from one controller
- Scripts are stored on the dv Prompter server's internal storage
- Multiple users can collaborate to the scripts library over IP
- Built in dual band WiFi
- Compatible with WR-450 Bluetooth controller to facilitate talent script control
- Small form factor, rack mountable using RMK-2
- 12V DC input

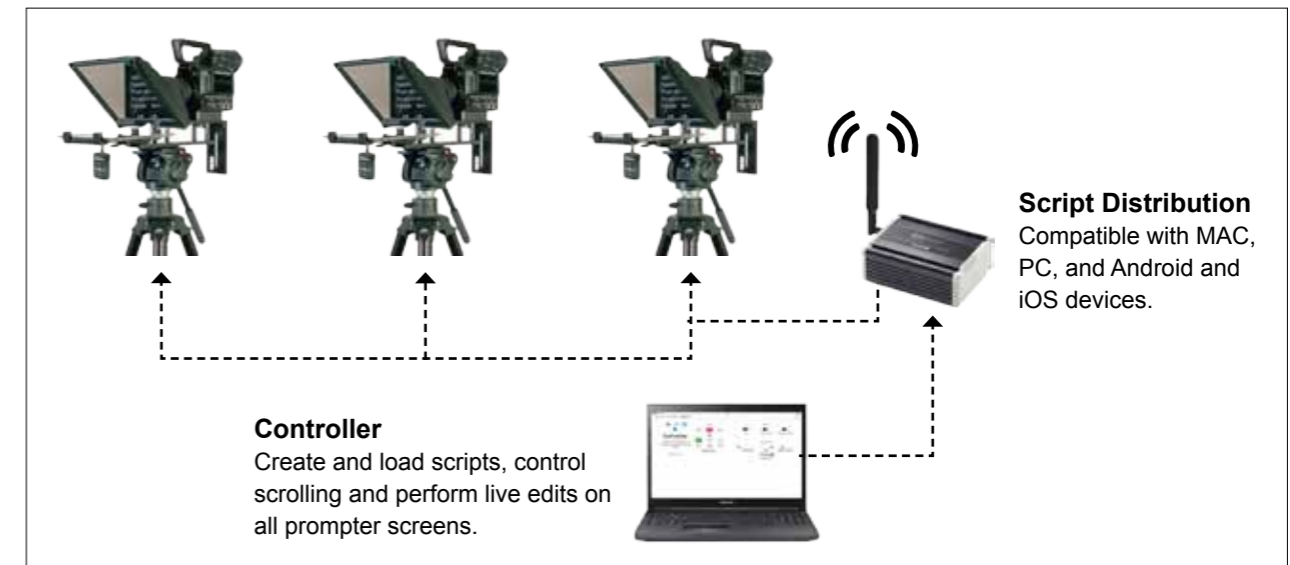

Applications



Corporate, AV and Education

Create programming with two presenters. Each anchor can have their own script with a teleprompter to guide them every step of the way. DVP-100 is controlled by a single operator who can easily manage and monitor the prompting scripts.



Broadcast

Ideal for live multi-presenter programs. Simply load up your script to the DV Prompter server and the DVP-100 allows you to sync up multiple teleprompters for seamless script delivery.

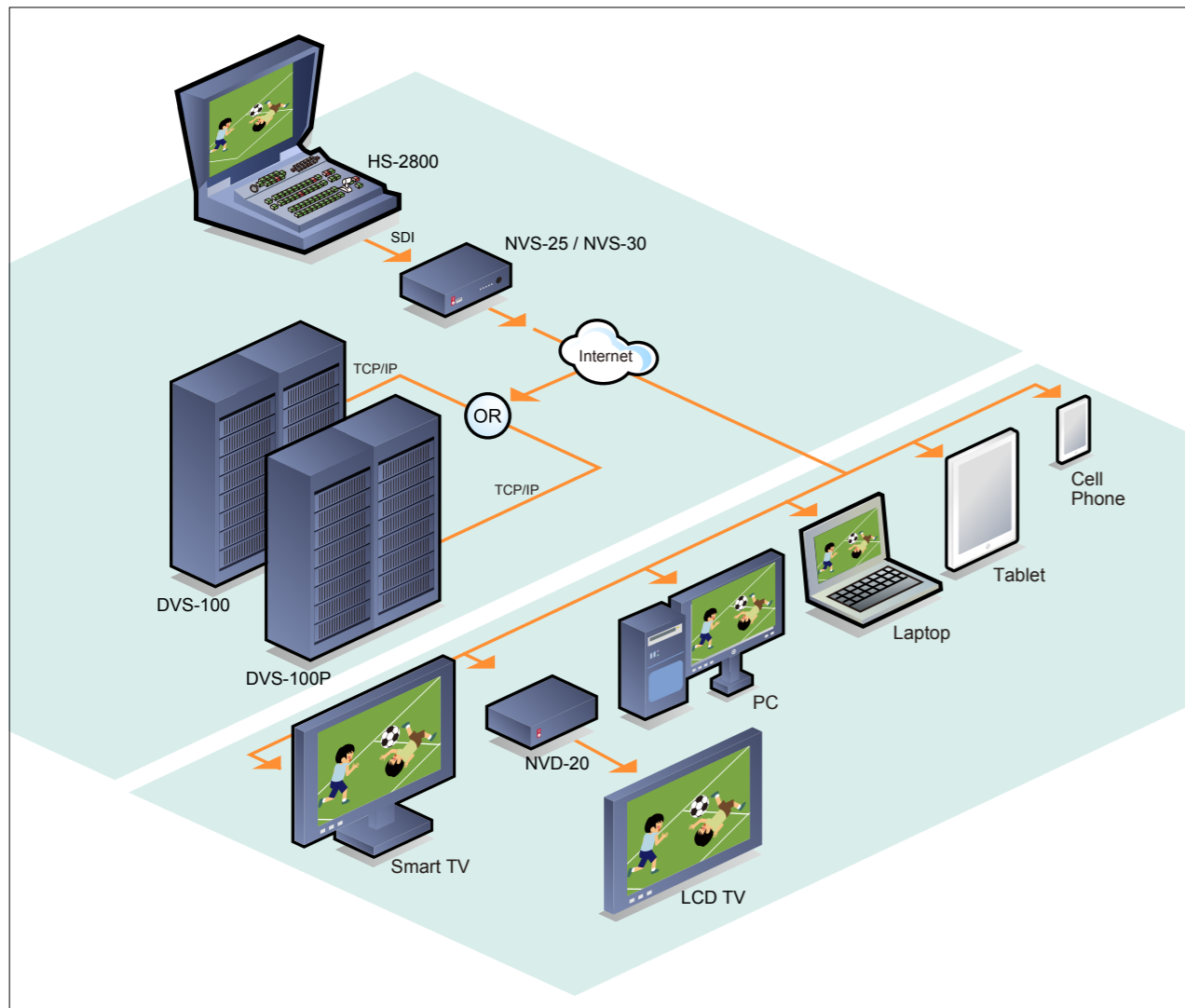

H.264 Video Streaming Server NVS-25

H.264



NVS-25 is a small, easy-to-use video streaming and recording appliance designed for professional video producers who need to simultaneously stream a live event and record for post-event editing. From any HDMI / SDI / CVBS input source such as a camera or switcher, NVS-25 generates an H.264-encoded stream compliant with RTSP / RTMP / HLS protocols. While encoding the video for live streaming, NVS-25 can simultaneously record a MP4 or .TS file to a USB storage device. NVS-25 is remotely controlled using a Windows / Apple PC or mobile device with a web browser. Designed for use on the desktop or in a rack.

- Broadcast quality HD / SD H.264 network streaming
- H.264 / AVC video CODEC, up to High Profile Level 4.0

- Input source: NVS-25 can accept SDI / HDMI / CVBS source input
- Flexible source input: Analog audio input for 2 channels (Audio input selectable Analogue <balanced/ unbalanced> or SDI/HDMI embedded source.) SDI and HDMI can also select
- Network feature: Support DHCP Client, RTSP over TCP/UDP/HTTP with MPEG TS. RTMP, HLS protocols. Unicast Only
- Flexible video scaler presets for streaming
- Supports 3 types of GOP structure: IBBP, IPPP and IBP
- Web UI for system configuration and FW upgrade
- Support De-interlaced video streaming output
- Storage by USB device (Up to 1TB storage device)

DV Streaming Server Pro DVS-100P

DVS-100P is a private streaming network that gives content owners and producers complete control over their media. Video can be viewed live or on demand by audiences, while the producer has complete control over the look of the channel and access to the media. The DVS-100P software is easily installed within a few clicks onto a local server or into the cloud. DVS-100P is designed to work seamlessly with Datavideo NVS and NVD encoders.

Chargeable upgrade for DV Stream Server. License per instance (i.e. per Cloud or Local Server). Adds the following features :

- Auto / Manual Record of Streams
- VOD
- Channel List Publish (2 lists : Live, On Demand) – upload your own files for playback
- Embedded Video Player
- Restrict viewing of certain channels to registered account holders



IP Video Decoder NVD-20/25



A wired IP video decoder with HDMI, Composite and analogue audio outputs. The NVD-20 decodes all common IP streams and can output HD/SD video at resolutions up to 1080p60. The NVD-20/25 is the perfect partner to the Datavideo NVS-25 IP encoder allowing full HD point to point video links over Ethernet, WiFi or the Internet.

- Operates on standard 10/100Mb Ethernet networks
- Excellent image quality with very low delay
- Unicast and multicast support
- Supports RTSP over UDP (Unicast/Multicast), RTSP over TCP, RTSP over HTTP, MPEG-TS over UDP, RTMP over TCP, UDP raw (Unicast/Mu1HLS over HTTP)

- Feature-rich WebUI for configuration and control
- Built in video scaler
- Simultaneous digital embedded and analogue audio output
- IR Control (via optional USB IR adapter kit, inc. IR Remote)
- Channel List Download from DV Stream Server Pro
- Channel Select and Volume Control (with optional IR adapter kit)
- Application to control multiple NVD units remotely over IP
- Output:
 - NVD-20: HDMI & CV
 - NVD-25: SDI & CV
- 12V DC input

Network Media Player NVP-20



The Datavideo NVP-20 is a fully automated remotely controlled H.264 video player. Video files can be added to the media player by copying to a USB device or can be transferred over the network using FTP.

The user can create and load playlists as well as remotely controlling video playback. With the addition of a USB keyboard, the NVP-20's on screen display means the unit can be used without IP control.

Video playback can also be triggered via GPI.

- Operates on standard 10/100Mb Ethernet networks
- Support multiple playlists

- Excellent image quality up to 1080p60
- Supports mp4, H.264, .mkv, .mov, .ts
- IP control supports play next clip, play all clips, loop play all clips, pause, resume and seek
- Supports NTFS and FAT/FAT32 formatted USB storage
- Feature-rich WebUI for configuration and control
- Built-in video scaler
- HDMI and Composite video output
- Supports simultaneous digital embedded and analogue audio output
- 12V DC input

Intercom System ITC-100



Good communication is vital in any production studio; keeping communication between the director, camera crew, lighting engineer and control room is essential to produce a polished end result. The Datavideo ITC-100 Intercom system provides 8-way talkback and tally indicators. The producer can talk to an individual channel or to all channels simultaneously. High S/N ratio makes the communication crisp and clear. The ITC-100 is a standard 19/1U rack design, so it is easy to integrate into any rack system for using in the field or studio.

- Standard 19/1RU rack design
- Supports 8-Way talkback (standard package includes 4 sets of ITC-100SL with belt-pack accessories)
- Additional external earphone and microphone interface
- Dual color tally light indicator
- Selectable channel talk, broadcast to all or mute
- Enables clean and clear communication between the camera crew and the director
- Communication distance up to 200m
- Supplied complete with gooseneck mic and light

HP-1 & HP-2A Headsets (Optional)

ITC-100 comes with the standard MC-1 Headsets. Also available are the special HP-1 and HP-2A Headsets.

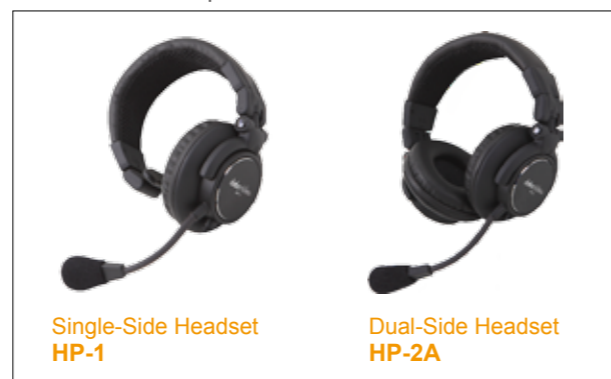

ACCESSORIES (INCLUDED)



ITC-100SL

Intercom belt pack
4 x ITC-100SL cameraman unit including carry case



CB-3/ CB-4

20m/50m 5-Pin Intercom Cable
4 x 20m/50m XLR to XLR intercom cable



TD-3

Tally Indicator
Supplied with 4 x camera-mounted tally lights



CB-7

1.2m GPI Cable
Connection TD-3 tally light with ITC-100 belt pack



MC-1

Microphone Headset
ITC-100 - supplied with 4 headsets.



MC-2/ LP-1

Gooseneck Microphone/ Gooseneck Light
XLR gooseneck mic & light

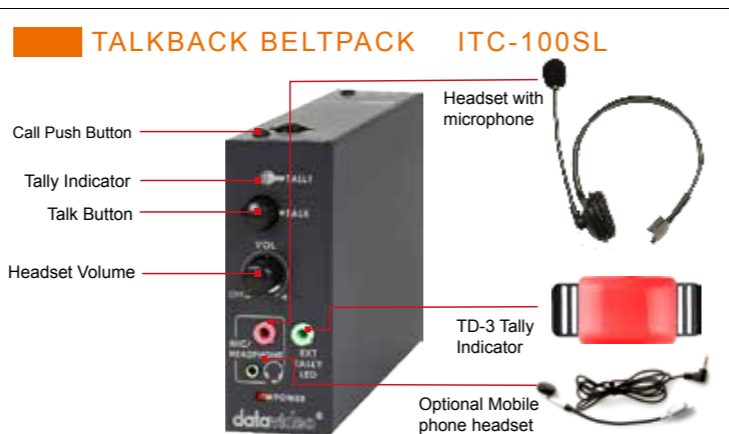

REAR VIEW

5 pin XLR connector provides bi-directional communication, tally signal and power in one cable

Dual Color Tally Light TD-3



TD-3 tally light provides the camera operator and the talent with clear information

HD/SD Chromakeyer DVK-300HD



DVK-300HD is easy and intuitive to use, delivering great results even in the most challenging environments.

Most HD chromakey systems are either complex computer-based solutions or are included in vision mixers with limited keying features. The DVK-300HD is ideal for users that simply need professional featured and affordable live keying in a portable device. DVK-300HD can be controlled by a computer directly or remotely over an IP network.

HDMI and SDI inputs make the DVK-300HD perfect in any live environment.

Model	DVK-300HD
Video Standard	3G/HD/SD
Video Format	1080p (25/30/50/59.94/60 Hz), 1080i (50/59.94/60 Hz), 720p (50/59.94/60 Hz), 480i (NTSC), 576i (PAL), Autodetect
Foreground Inputs	1x 3G/HD/SD-SDI, 1x HDMI (1.4)
Background Inputs	1x 3G/HD/SD-SDI, 1x DVI-I
Loop Through	N/A
Output	2x 3G/HD/SD-SDI, 1x HDMI
Keying Options	Chromakey Green / Blue, Lumakey
Key Mask/ Spill Correction/ Edge Correction	Yes
Color Processor	Foreground: Brightness, Contrast, Saturation, Ambient Intensity
Noise Reduction	Yes
User Preset	4
GPI In/Out	N/A
Controlled Via	Ethernet/ RS-232
Chassis	1RU 19" Rack-mount Design

Green Color Plastic Mat MAT-2/ 5

MAT series plastic mat is for floor use. It is water proof and easy to clean.

Plastic Mat	Color	Size (m x m)	Thickness
MAT-2	Green	1.8x27	0.6 mm
MAT-5	Green	1.8x54	0.35 mm



Green Color Tape TA-1/ 2



Tape	Color	Size (mm x m)
TA-1	Green	48x25
TA-2	Green	96x25

3 Light Portable Lighting Kit PLK-300



- 3 x 308 LED Bi-Colour Lights
- 3 x Lighting Stands
- Wheeled hard case

4 Light Portable Lighting Kit PLK-400



- 3 x 308 LED Daylight Lights
- 1 x 160 LED Bi-Colour Light
- 4 x Lighting Stands
- Wheeled hard case

Model	PLK-300	PLK-400
308 LED	3x Bi-Colour	3x Day Lights
160 LED	N/A	1x Bi-Colour
Mains Power Supplies	N/A	4
Lighting Stands	3	4
Wheeled Hard Case	Yes	Yes

Sampling Vector Scope Monitor VSM-100



Accurate video signal analysis and calibration has always been crucial to any live production.

Datavideo VSM-100 and VSM-200 waveform / vectorscope monitor series seamlessly integrate into a compact 19 rack system to ensure consistent and legal color and luminance video levels. At 2RU, they are perfect for use in a production van or any space-limited setup.

VSM-100 has a single waveform / vectorscope unit while VSM-200 features dual scopes. Both models come with two LCD screens, thus no external monitors are required; as such it's highly cost effective.

- VSM-100: one waveform / vectorscope unit with two 4.3-inch HD monitor screens
- VSM-200: two waveform / vectorscope unit with two 4.3-inch HD monitor screens
- Sampling vectorscope
 - HD/SD-SDI input
 - HDMI and HD/SD-SDI output, SDI output can be assigned as video source loop out or vectorscope display
 - Auto-detect NTSC, PAL and HD signals
 - Support four analysis modes: waveform, vectorscope, parade (YCrCb & RGB) and histogram

- Save and Recall traces for easy comparison of different video signals
- Video input thumbnail with selectable 16:9/4:3 aspect ratio
- Vectorscope reticle can be toggled between 75% and 100%
- Waveform detail can be zoomed 20%, 40%, 60% and 100% - adjusting horizontal delay to view parts of the waveform
- Support embedded audio with on-screen audio level meter for up to 8 selecteable channels

- Monitor screens
 - Each monitor has one HDMI and one HD/SD-SDI input with loophrough output
 - Auto-detect NTSC, PAL and HD input signal
 - Individual adjustments of brightness, contrast, color saturation and back light level for each monitor
 - Support blue only function, safe area marking and Timecode display
 - Support embedded audio on SDI, HDMI
 - Audio monitoring via on-screen audio level indicator and front panel headphone jacks
 - 4:3 & 16:9 display mode switching
- Standard 19-inch rack size, 2RU height, easy for system integration



	VS-100	VS-150	VSM-100	VSM-200
Product Name	Waveform/ Vector Scope	Waveform/ Vector Scope	Waveform/ Vector Scope	Waveform/ Vector Scope
Video Inputs	1x HD/SD-SDI	1x HD/SD-SDI	1x HD/SD-SDI	2x HD/SD-SDI
Video Outputs	1x HDMI	1x HDMI	1x HD/SD-SDI, 1x HDMI	2x HD/SD-SDI, 2x HDMI
Loop Through	1x HD/SD-SDI	1x HD/SD-SDI	N/A	N/A
Audio Inputs	Embedded Audio through SDI interface			
Audio Outputs	1x 2-Channel 3.5mm stereo phone jack			
Input Resolutions	1080i (50, 59.97, 60Hz), 1080p (24, 25, 30Hz), 720p (25, 29.97, 30, 50, 59.97, 60Hz), 576i, 480i			
Additional I/O	---		LCD 1 & LCD 2 input: SDI, SDI Loop thru & HDMI	

Audio Delay Box with Level Adjustment AD-200



Datavideo AD-200 combines 6-channel audio delay with a matrix mapping function for its 4-channel output audio mixer. The system is made up of a front panel and main unit, 2 separate 1RU units which can be easily installed in an OB Van or customized rack.

AD-200 features a 6-CH audio mixer with level adjustment

and audio delay capabilities. The matrix-type audio mapping function allows a combination of multiple audio input channels into one or more output channels. Up to 3 seconds of delay are available to synchronize audio with video.

AD-200 is user-friendly with a clear OLED display and supports 2 audio inputs for a microphone or line input.

Audio Delay Box with Microphone Input AD-100M



AD-100M is a single channel audio delay box, enabling synchronisation of audio and video.

The unit features RCA (phono) connector as well as XLR type connection. Built in a rugged metal housing for use in the field or studio.

- RCA (phono) connector as well as XLR type
- Output volume attenuating 0-60dB
- Audio delay time from 0-700ms 1KHz tone output
- 1x XLR mic in

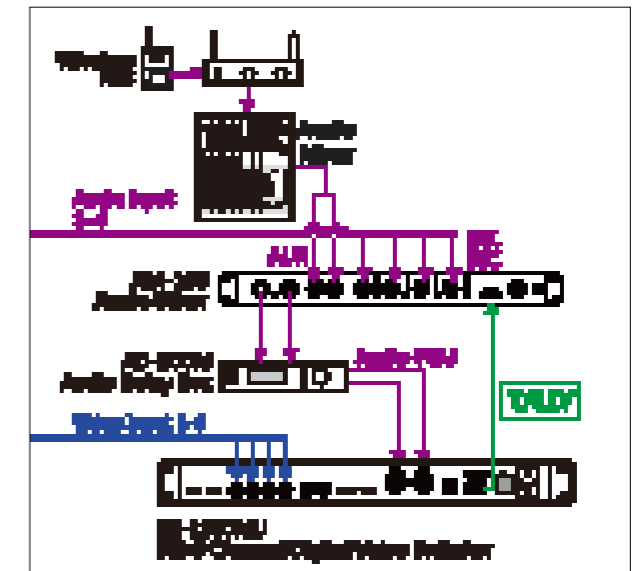

Model	AD-200	AD-100M
Audio Input	6x XLR, 2x RCA	3x XLR (2 for Line-in, 1 for Mic-in), 2x RCA
Audio Output	4x XLR, 2x RCA, 1x 3.5mm	2x XLR, 2x Unbalanced RCA
Audio Indicator	1.77" Color OLED	SMT LCD
Audio Delay	Up to 3 Seconds	Up to 700ms
Special Feature	Audio Delay and Mix, delay by channel	N/A
Chassis	2 units, rack-mount mainframe	Rack-mountable with RMK-1 Rackmount Kit
Power	DC 12V 19W (front) / DC 12V 16W (rear)	DC 12V 18W

Camera Power Center

PD-6



PD-6 is a 19-inch, rack mountable, universal AC to DC Power Distribution Center, designed to supply steady and sequenced voltage for production kit while on location or in the studio. Perfect for use in conjunction with studio equipment and the CB-22H / CB-23H via a single power cable. Each of the eight outputs can be configured individually, DC48V, 24V, 14.4V & 12V, with a total power consumption of 360W. PD-2A 400 watts 1RU 19 rack Power Distribution Center provides a steady power supply for studio

equipment, such as the video switcher, monitors, recorders and intercom system. It features auto-switchable inputs of AC 110V/220, a UPS interface and DC 12V ports. PD-2A has 4 12V/3A terminals, two 12V/5A terminals, two 12V/10A terminals (shared)

and XLR DC outputs. It provides up to 400 Watts. The PD-2A adds reliability to studio equipment and consolidates power supplies and cabling. Datavideo PD-4A Power Distribution Center comes with two AC power supplies to provide instant fail-over redundancy. PD-4A provides multiple DC 12V outputs. The automatic port control sequencer intelligently initiates each output to ensure the power supply on start-up. The PD-4A can also be powered from a regulated DC 12V power source. It can run from a car or van's power outlet with the use of a suitable regulator.

Model	PD-2A	PD-4A	PD-6
Product Name	Studio Power Distributor	Redundant Power Centertributor	Camera Power Distributor
AC input	100~240 VAC (50Hz or 60Hz) AC input outlet: One AC input with Power Switch	100~240 VAC (50Hz or 60Hz) AC input outlet: Two AC inputs & Two Power Switches	100~240 VAC (50Hz or 60Hz) AC input outlet: One AC input with Power Switch
DC Backup Input	One DC 12V/32A supports non-regulated DC 12V output	One DC 12V/25A supports non-regulated DC 12V output	N/A
DC Outputs	8 12V±5%, 3A XLR DC Female Jack x4 12V±5%, 5A XLR DC Female Jack x2 12V±5%, 10A XLR DC Female Jack x2	5 12V±5%, 5A XLR DC Female Jack x3 12V±5%, 10A XLR DC Female Jack x1 (share of two XLR DC Jack)	8 30W:12V(2.5A), 14.4V(2A), 24V(1.25A), 48V(0.6A) 60W:12V(5A), 14.4V(4A), 24V(2.5A), 48V(1.25A) PIN 1:GND PIN 2:DC OUT PIN3/4:NC
Max. Power Rating	400W	360W	360W
DC Overload	DC overload protection, auto-recovery fuses on each DC output terminal	DC overload protection, auto-recovery fuses on each DC output terminal	Protection type: Recovery automatically after fault condition is removed
AC Overload	non-recovery fuse on the AC input outlet	non-recovery fuse on the AC input outlet	non-recovery fuse on the AC input outlet
LED Indicator	8 DC output LED indicators	Green LED: Unit under working condition Red twinkle: AC Input failed 1~4 XLR DC outputs LED indicator	LED Color Indicator: Red:48V, Weak Red:24V, Green:14.4V, Blue:12V
Power source Input	Selectable of Auto/AC input switch Select AUTO/AC	Selectable of Auto/AC input switch	N/A

DC to DC 12/8.4/7.2V 4A Converter

DDC-4012H



A stable power supply is vital for safely operating cameras on external power. Datavideo DDC-4012H DC to DC converter is a solution that converts DC 15V~50V to 12/8.4/7.2V power output in order to protect camcorder with stable power

- Aluminium housing
- DC12V +/- 3%
- Velcro for mount on tripod

DDC-4012H		
Input	Voltage Range	15V~50V DC
	Efficiency(Typ.)	UP TO 85%
Output	DC Voltage	7.2V / 8.4V / 12V
	Voltage Tolerance	±3%
	Rated Current	4 A
	Current Range	0~4 A
	Rated Power	48W
	Ripple & Noise(Max)	<400mV
Protection	Over Load	105%~150% rated output power
		Protection type: Recovery automatically after fault condition is removed
Connector	DC Input (4Pin XLR Male)	PIN 1:GND, PIN 2: DC IN, PIN3/4: NC
	DC Output(4Pin XLR Female)	PIN 1:GND, PIN 2/3:NC, PIN4: DC OUT
	DC Output (5.5Mm DC Jack)	Center: DC OUT , Shell: GND
Environment	Working Temp	0°C to 40°C (32°F to 102°F)
	Working Humidity	10% to 90% (non condensing)
	Storage Temp.humidy	-40°C to +85°C, 10~95% RH
Others	Dimension	115 mm x 50 mm x 35 mm (L x W x H)
	Weight	Approx. 0.3 kg/ 0.66 lbs
	Cable	UL 2464 , 18AWG, L=1M
	Slide Switch	Selected 7.2V or 12V output
	LED Lamp	RED:DC out 12V, Green: DC out 7.2V, Orange: DC out 8.4V

SDI Audio De-embedded Box

DAC-90



DAC-90 is an audio de-embedder box that allows users to de-embed 16 analog audio signals (4 at a time) from SDI video signal. It features 3G/HD/SD-SDI to support up to 1080p/60 video, automatically detecting and switching between different formats, and provides 4 mini XLR audio connectors for outputting analog audio to audio devices such as, recorders, switchers, and audio mixers. The Audio box also has SMPTE and EBU settings.

SDI Audio Embedded Box

DAC-91



DAC-91 is an audio embedder that allows users to embed 2 channels of analog audio into an SDI video signal. It features 3G/HD/SD-SDI to support up to 1080p/60 video, automatically detecting and switching between different formats, and provides mini XLR and RCA audio connectors for inputting embedded analog audio. The audio box also has audio level adjustment.

Model	DAC-90	DAC-91
product name	SDI Audio De-embedder	SDI Audio Embedder
SDI Video Input	3G/HD/SD SDI x 1	3G/HD/SD SDI x 1
SDI Video Output	3G/HD/SD SDI x 1 (Re-clocked Loop through)	3G/HD/SD SDI x 2
Analog Audio Input	N/A	Mini XLR (balanced) x 2 ,RCA (unbalanced) x 2 * Mini XLR1 & RCA1 mixed to CH1 * Mini XLR2 & RCA2 mixed to CH2
Analog Audio Output	Mini XLR (Balanced) x 4	N/A
Indicator	Power LED x 1 Audio Level LED : 4 rows	Power LED x 1 Audio LED : 2 rows
Updates and Configuration	Mini USB x 1	Mini USB x 1
Audio Format Selection	SMPTE, EBU	SMPTE, EBU
Gain	N/A	Yes

Audio Isolation Transformer

DAC-80



DAC-80 is designed to remove hum and buzz created by ground loops. Voltage differences between different pieces of equipment cause small AC power currents to flow within the shield of audio cables. Capacitance issues can also introduce small current flows within the cable shield. Both problems will create hum in audio signals. DAC-80 delivers the clean audio signal you need, yet remains transparent within the production chain.

Balanced/ Unbalanced Audio Converter

BAC-03



- Stereo Balanced Audio In / Out via XLR Sockets
- Stereo Unbalanced Audio In / Out via Phono Sockets
- Robust Metal Construction
- DC12V Power Adapter

HDMI 30m/50m/100m Active Optical Cable

CB-60/ 61/ 62



CB-60/61/62 are HDMI active optical cable (AOC) with high performance, low power consumption and low cost. Using optical fiber to replace copper wire as the high-speed signal transmission medium, the cable can perfectly transmit 4K@60Hz UHD image up to more than

100 meters. Compared with the traditional copper wire, the cable is much longer, softer, more slim, with better signal quality and perfect EMI/EMC feature. The cable is easy to use, has perfect compatibility and no external power supply needed.

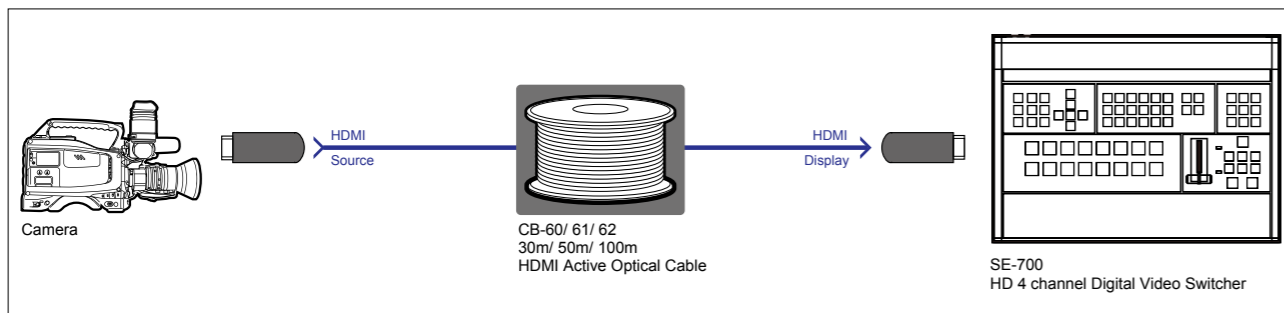

HD/SD 30m/50m/100m 2-in-1 Cable (HD-SDI/ITC)

CB-46/ 47/ 50

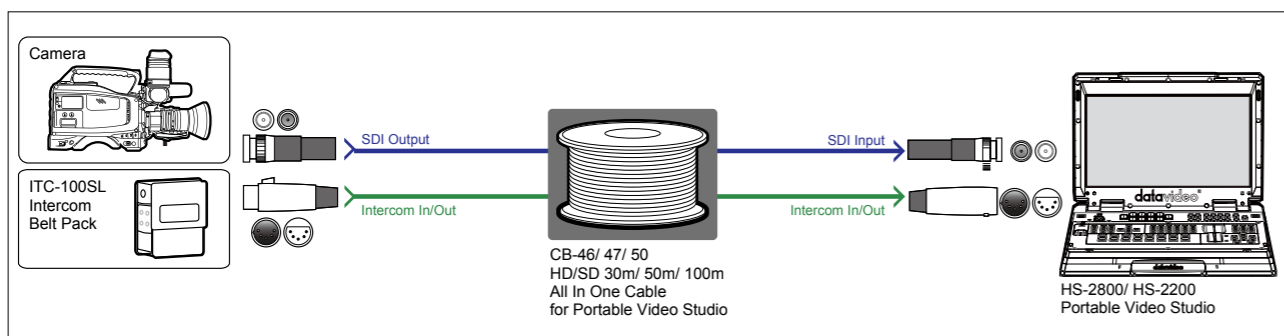

HD/SD 30m/50m 4-in-1 Cable for Multi-Camera Control (HD-SDI/ITC/CV/Cat-5)

CB-30/ 31

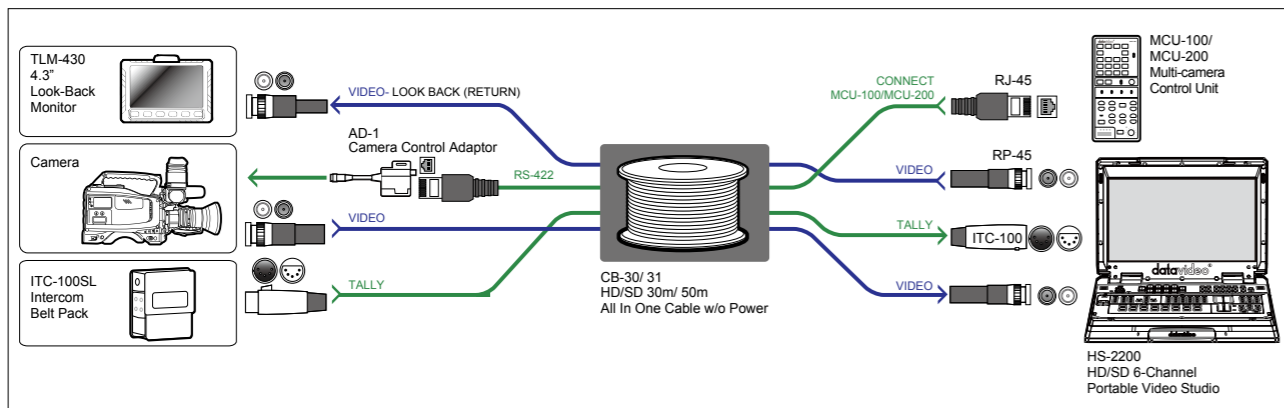

HD/SD 30m/50m 4-in-1 Cable (HD-SDI/ITC/CV/DC Power)

CB-22H/ 23H

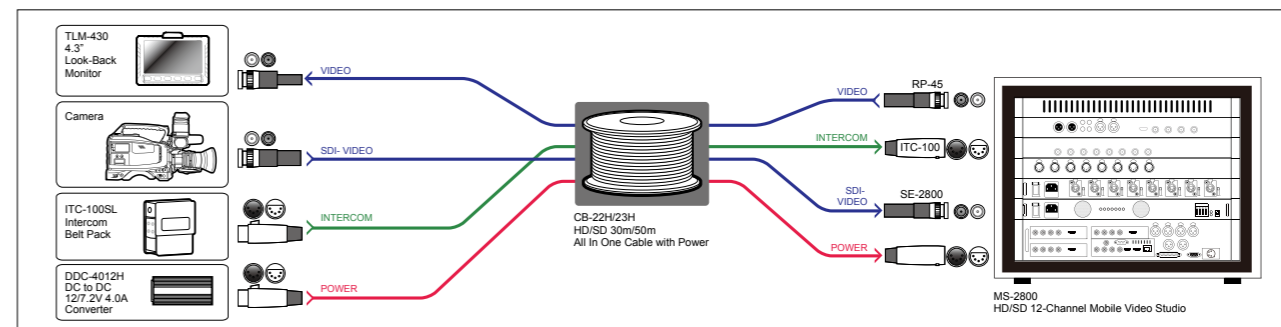

Model	CB-22H/ 23H	CB-30/ 31	CB-46/ 47/ 50
Product Name	HD/SD All In One Cable with Power	HD/SD All In One Cable w/o Power	HD/SD All In One Cable for Portable Video Studio
Interface	- 1 x 4-pin XLR power cable - 1 x 5-pin XLR ITC/Tally cable - 1 x 75Ω BNC for HD/SD SDI video - 1 x 75Ω BNC for CV return video	- 1 x 5-pin XLR ITC/Tally cable - 1 x 75Ω BNC for HD/SD SDI video - 1 x 75Ω BNC for CV return video - 1 x CAT-5 cable for Camera control	- 1 x 75Ω BNC for HD/SD-SDI video (3 C2V) (CB-46/ 47) - 1 x 75Ω BNC for HD/SD-SDI video (2.5 CHD) (CB-50) - 1 x 5-pin XLR ITC/Tally cable
Length	CB-22H: 30m, CB-23H: 50m	CB-30: 30m, CB-31: 50m	CB-46: 30m, CB-47: 50m, CB-50: 100m
Repeater	VP-605H	VP-633 and VP-634	VP-633, VP-634 and VP-781
Applications	- Intercom & Tally - DC Power 12~48V - Video (including HD-SDI) - Return video for Look Back monitor - Datavideo OBV or Mobile Studio	- EFP Multi-camera Operation - Mobile Video Studio	- Intercom & Tally - Video (including HD-SDI 1080p) - Range of Datavideo Mobile or Portable Video Studio

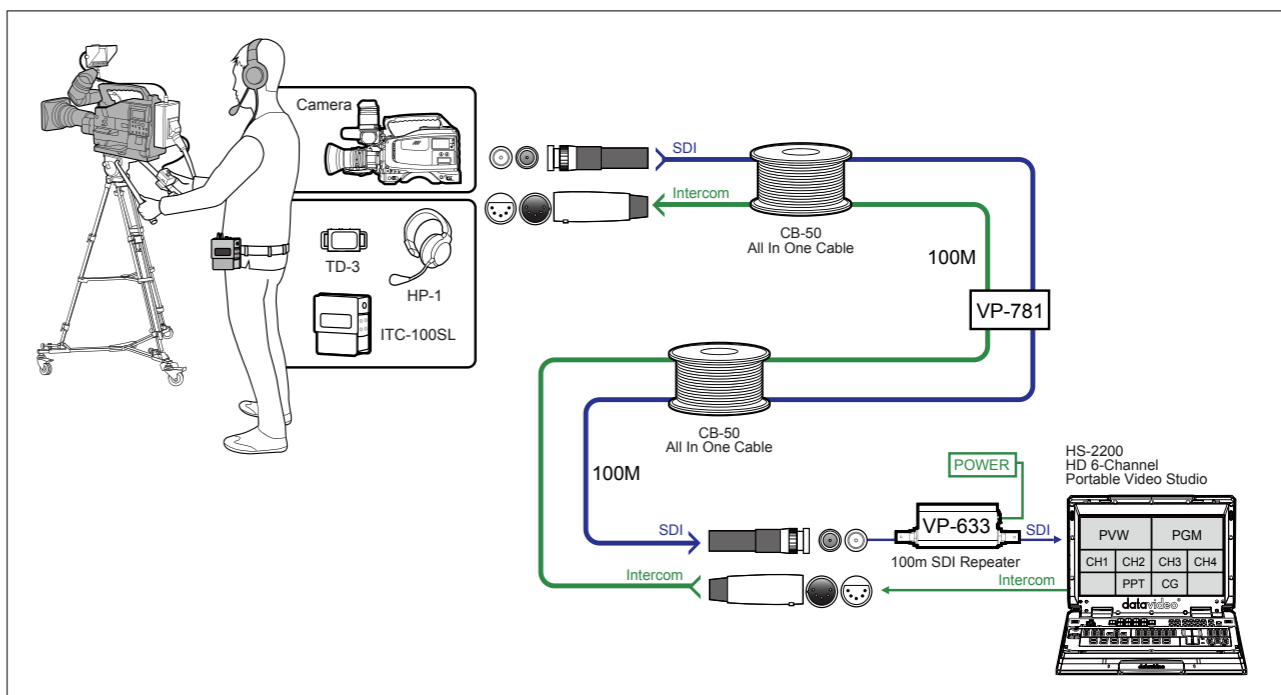

2x6 3G HD/SD-SDI Distribution Amplifier VP-597



- 2 x 3G/HD/SD-SDI inputs
- 6 x 3G/HD/SD-SDI distribution outputs
- Supports embedded audio SDI
- Supports video formats:
 - 3G-SDI | HD-SDI: 1080p 50/59.94/60/ 23.98/24/25/30
 - SD-SDI 1080i 50/59.4/60/525i /625i/720p/50/59.94/60
- Two input video sources can be controlled by A/B switch or GPI remote

1x4 HD/SD-SDI Distribution Amplifier VP-445



- Four way HD/SD-SDI distribution amplifier with embedded audio
- Supports Multi-Standard of HD-SDI (SMPTE 292M), SD-SDI (SMPTE 259M and SMPTE 334M)

HD/SD SDI and Intercom Repeater Box VP-781



The VP-781 HD/SD-SDI with Intercom repeater is designed to cascade CB-50 cables, extending the transmission range of video, audio and intercom signals. To connect VP-633 that the VP-781 is able to extend video up to 200M.

- Extend HD/SD-SDI, Intercom and Tally signal up to 200m
- Cascade CB-46/ 47/ 48/ 50 All in one cable for signal extension
- Incorporates VP-634 HD/SD SDI Repeater inside and 5Pin XLR Intercom pass-through

Composite Signal Repeater VP-737



Extend a composite signal up to 200 meters away over a Cat5e (or better) cable. With no software configuration requirements, the installation and setup is quick and hassle-free.

- Wired composite video transmission as far as 200 meters
- Completely adaptive - quick, easy installation and setup, no configuration required
- Cat5e extension design make use of existing Cat5e or better wiring infrastructure

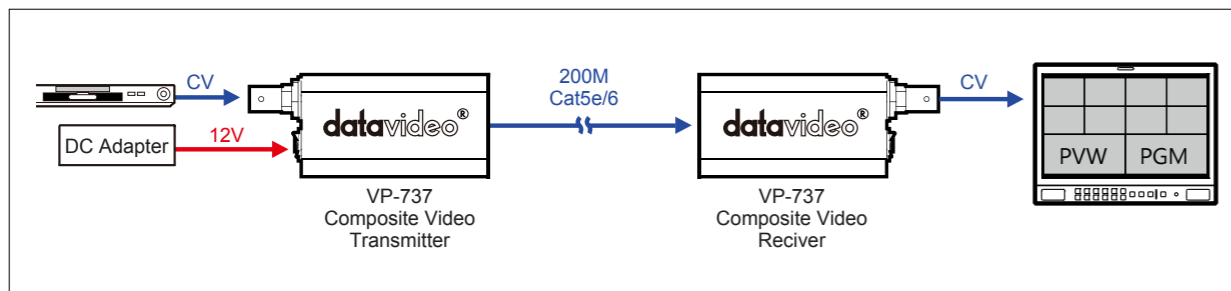

100m SDI Repeater (Unpowered/Powered) VP-634/ 633



VP-633/VP-634 SDI repeaters can significantly extend the maximum cable run of standard SDI cabling.

Up-to 4 SDI repeaters can be used in one chain, allowing runs of up to 1000m SDI video through good quality SDI cable.

Each run must contain a VP-633 as this has a power connection to supply power through the SDI cables which then powers the subsequent VP-634's (which do not require additional power). For applications where runs of a few hundred meters HD-SDI video are required (concert hall, sports stadium etc.), the Datavideo VP-633 & VP-634 are a very cost effective solution.

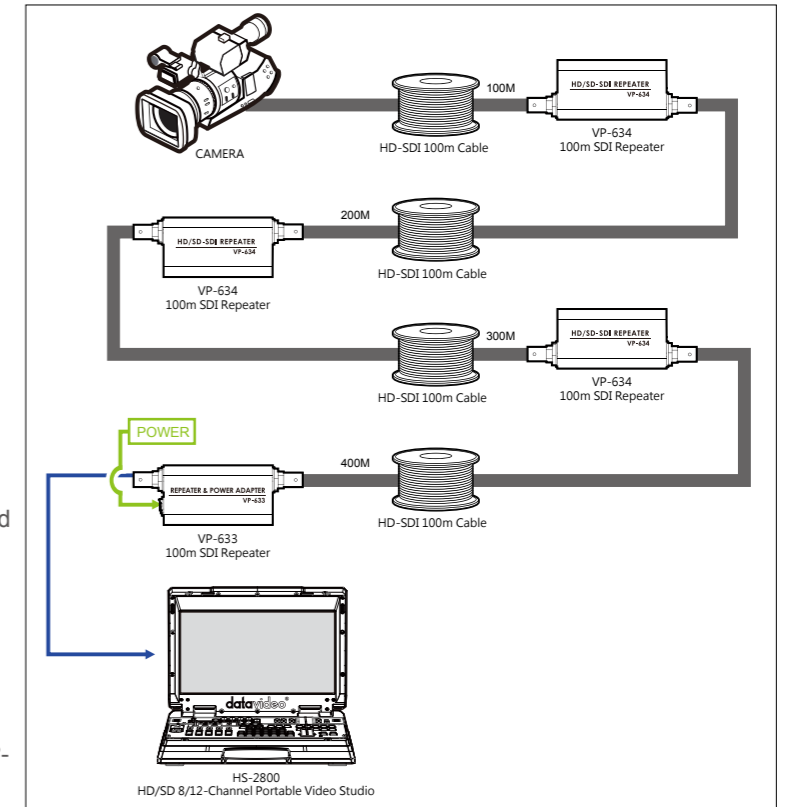

All In One Cable Extender VP-605H

The all-in-one signal repeater provides composite video, power, and intercom connections. It's perfect for use with the CB-22H / CB-23H cables.



Model	VP-605H	VP-633/634	VP-737	VP-781
Product Name	All In One Cable Extender	100m SDI Repeater	Composite Signal Repeater	HD/SD-SDI Repeater
Video and Signal	Input: HD/SD-SDI · CV · Talkback, Tally, DC in Output: HD/SD-SDI · CV · Talkback, Tally, DC out	Input: HD-SDI/SD-SDI Output: HD-SDI/SD-SDI	Transmitter - CV Input (BNC) - DC Input - CAT 5 Output (RJ-45) Receiver - CV Output (BNC) - CAT 5 Input (RJ-45)	Input: HD/SD-SDI, Talkback, Tally Output: HD/SD-SDI, Talkback, Tally
Standard	SD: SMPTE 259M HD: SMPTE 292M	SD: SMPTE 259M HD: SMPTE 292M	SD: SMPTE 259M	SD: SMPTE 259M HD: SMPTE 292M
Video Format	SD : 720x480i · 720x576i HD : 1280x720 50P / 59.94P / 60P 1920x1080 50i / 59.94i / 60i 1920x1080 24P / 25P / 30P	SD : 720x480i · 720x576i HD : 1280x720 50P / 59.94P / 60P 1920x1080 50i / 59.94i / 60i 1920x1080 24P / 25P / 30P	625i PAL, 525i NTSC	SD : 576i PAL, 480i NTSC HD : 1080p 24 / 25 / 30 1080i 50 / 59.94 / 60 720p 50 / 59.94 / 60
Audio	SDI Embedded Audio	SDI Embedded Audio	N/A	SDI Embedded Audio
Power	DC 25V ~ 48V	DC 12V ~ 25V (VP-633 only)	DC 12V	N/A

Trackless Virtual Studio System

TVS-1000 TVS-1200

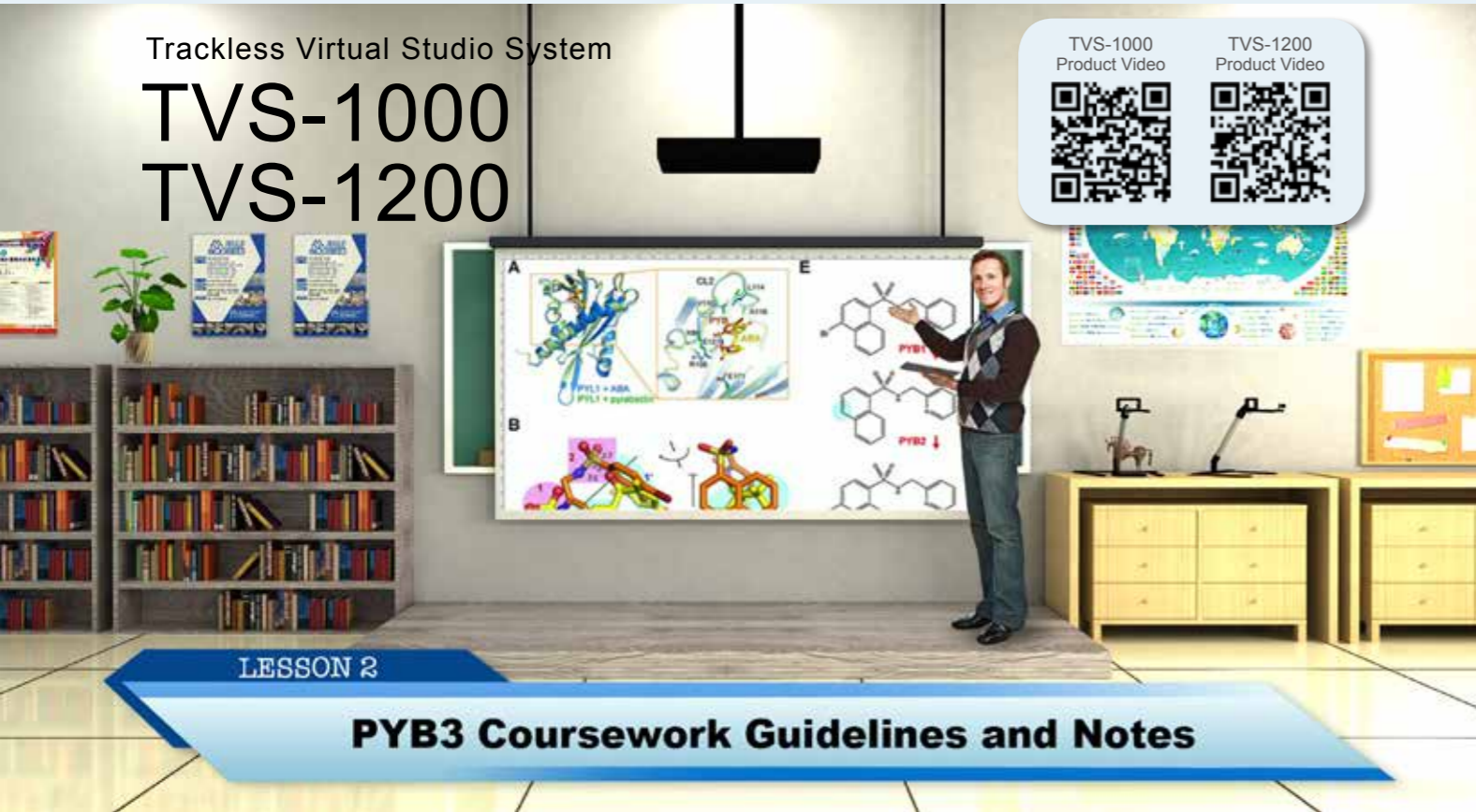

The TVS-1000 and TVS-1200 is a 5 in 1 design which consists of a trackless virtual studio system, video switcher, character generator, video recorder and web streaming encoder. It's a versatile, easy to use and cost-effective solution. TVS-1000 and TVS-1200 are suitable for production companies, corporate producers, users in education, small studios and TV stations. As a virtual studio solution, TVS-1000 and TVS-1200 support pan, tilt and zoom camera movements for dynamic effect. The built-in Virtualset Maker allows users to fully customize their sets: User can easily insert background images, add logos to any surface, and run video in the backdrop. In addition, user can download professional studio templates on <http://www.datavideovirtualset.com>

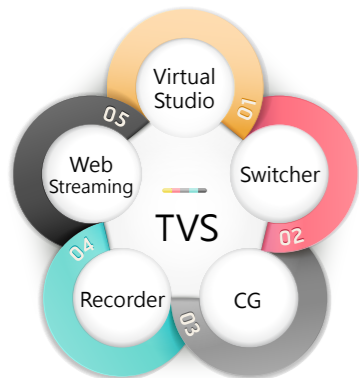

- Five in One: Virtual Studio, Switcher, Charter Generator, Recorder and Web Streaming
- 9-ch switcher by 1 HDMI camera input (TVS-1000) or 10-ch switcher by 2 SDI inputs (TVS-1200)
- 4 virtual camera operation, each camera supports 3 phases (pan, tilt, zoom movements)
- Support additional TVS-AUX Card to have one more input
- Mini phone jack audio input, audio embedded to PGM HDMI output
- 2 x DSK to add CG and animation to the scene
- Chromakey function delivers perfect keying
- 30 free virtual set backgrounds are included
- TVS-1000 control panel (RMC-220) included
- Virtualset maker software is included.

TVS Main Unit with Control Panel RMC-220

RMC-220 TVS control panel provides users with easy control of the TVS Virtual Studio System. RMC-220 equipped with 10 function keys, which can directly trigger the assigned function by pressing the corresponding key.



TVS-1000 and TVS-1200 Key Functions

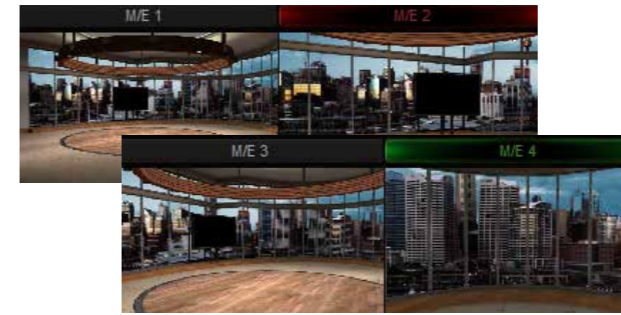

With one camera input (TVS-1000) or two camera inputs (TVS-1200), TVS trackless virtual technology can simulate up to four cameras with different shooting angles. Each camera has its own natural pan, tilt, zoom movement just like real camera actions.

TVS series includes the free virtual set maker software to create your own virtual set.



Live stream your show ! You just need to click one button, and your show is online. We have preset the most common streaming services. Alternatively, you can customize your preferred service profiles as well.

TVS-AUX card (Optional)

TVS-AUX capture card is specially designed for displaying media files via an HDMI port. It supports files from popular applications such as PowerPoint and various media players. The TVS-AUX card can be used by the TVS-1000 and TVS-1200 systems.

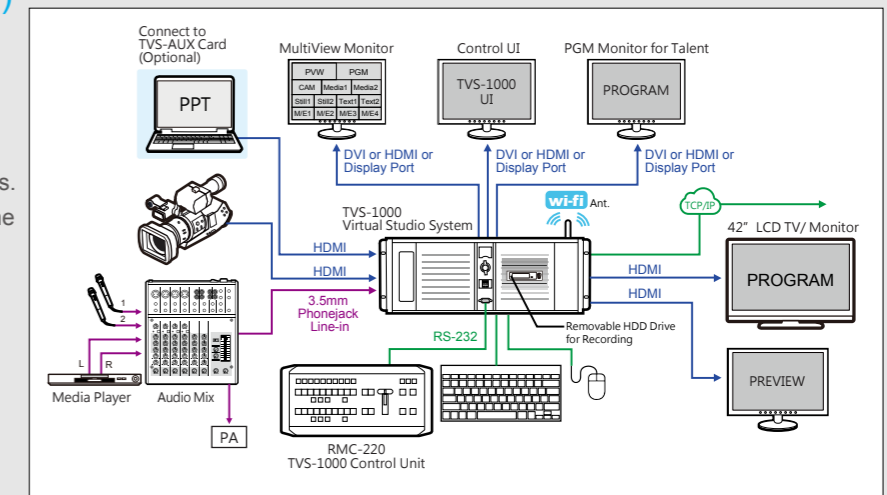

	TVS-1000	TVS-1200	TVS-AUX
Video Input	HDMI x1	SDI x 2	HDMI x1
Video Output	HDMI x 1	SDI x 2	HDMI x 1
Video Input Format	1080 30P/29.97P/25P 1080 60i/59.94i/50i 720 60P/59.94P/50p	1080p 60/59.94/50/29.97/25 1080i 60/59.94/50 720p 60/59.94/50	1080 30P/29.97P/25P 1080 60i/59.94i/50i 720 60P/59.94P/50p
Audio Input	Mini Phone Jack x 1 HDMI audio embedded	Mini Phone Jack x 1 SDI audio embedded x 2	Mini Phone Jack x 1 HDMI audio embedded
Tally	NO	YES	NO
Downstream Key	2	2	
Media	2(DDR)	2(DDR)	
Still Picture	2	2	
Still Text	2	2	
Keyer	Chromakey/ Luminance key	Chromakey/ Luminance key	
Recording Format	H.264/ MPEG-2 up to 25Mbps	H.264/ MPEG-2 up to 25Mbps	
Live Streaming	TS HTTP/ TS RTP/ TS UDP TS RTSP/ FLV HTTP/ FLV RTMP	TS HTTP/ TS RTP/ TS UDP TS RTSP/ FLV HTTP/ FLV RTMP	
System Capacity	1TB	1TB + 240G SSD	

TVS-1200 Key Applications

Two SDI camera inputs provide more flexibility and creative videos. TVS-1200 is perfect to use in talk shows and the broadcast market.

Two Cameras in Studio



Having two cameras in a virtual studio system can help you to make the show more vivid.



Free Virtual Set

datavideovirtualset.com
Download free virtual set backgrounds from datavideovirtualset.com

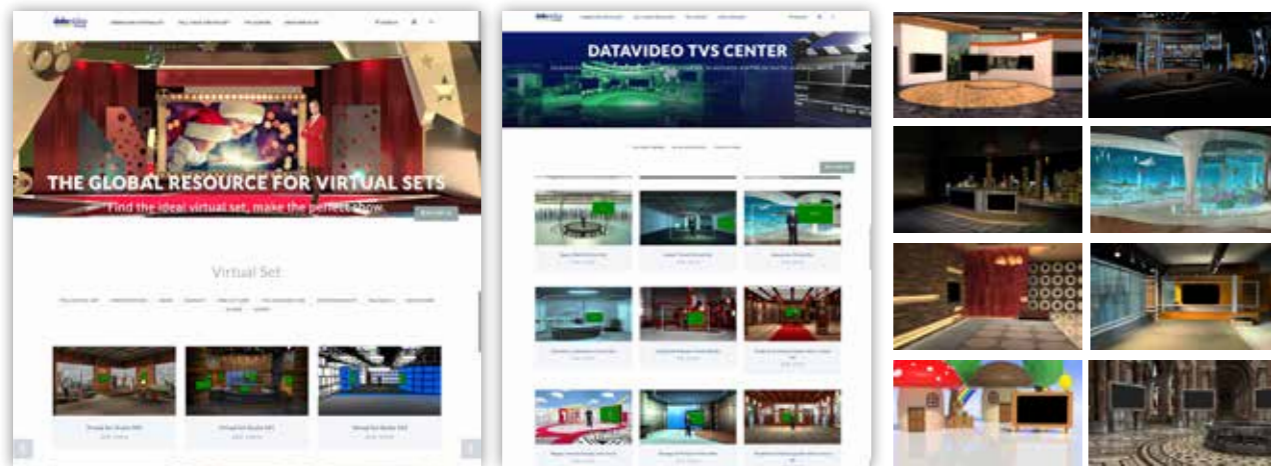

Virtual Interactive Green Board System

VGB-1000F/R



As long distance learning becomes a central part of modern education, the demand for advanced lecture recording equipment is increasing. Typically, teaching materials are recorded using a large LCD touch screen and an HD camera. This method is expensive yet images taken by the camera are washed out and can be difficult to read. Today, with the modern virtual studio and chromakey techniques, the user is able to achieve fantastic results that enhance the learning experience.

Stock Analysis



Weather Forecast



Chemistry Course

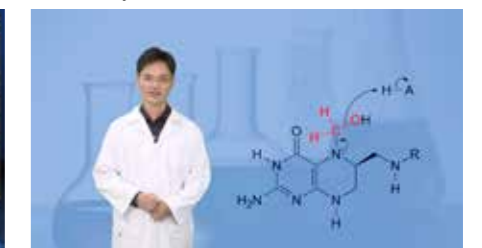

Lecture Recording



Lecture Recording



Technical Training



VGB-1000 Product Series

VGB-1000R Virtual Electronic Green Board System - PlanA



Datavideo's innovative RPK-1 rear projection kit allows you to use in any space so that any office can become a professional studio.

Rear View

VGB-1000R Virtual Electronic Green Board System - PlanB



Plan B is primarily focused on the dual purpose design. The bigger green backdrop is for taking the full shot of the talent. Hence, in addition to VGB applications, the VGB-1000R Plan B can also be used in taking various other full shots on the green backdrop, allowing you to achieve two things with just one product.

VGB-1000F Virtual Electronic Green Board System



The VGB-1000F front projection Virtual Electronic Green Board System is a simple design. All you need to do is install a projector on the wall to have a complete Green Board System. The installation is easy.

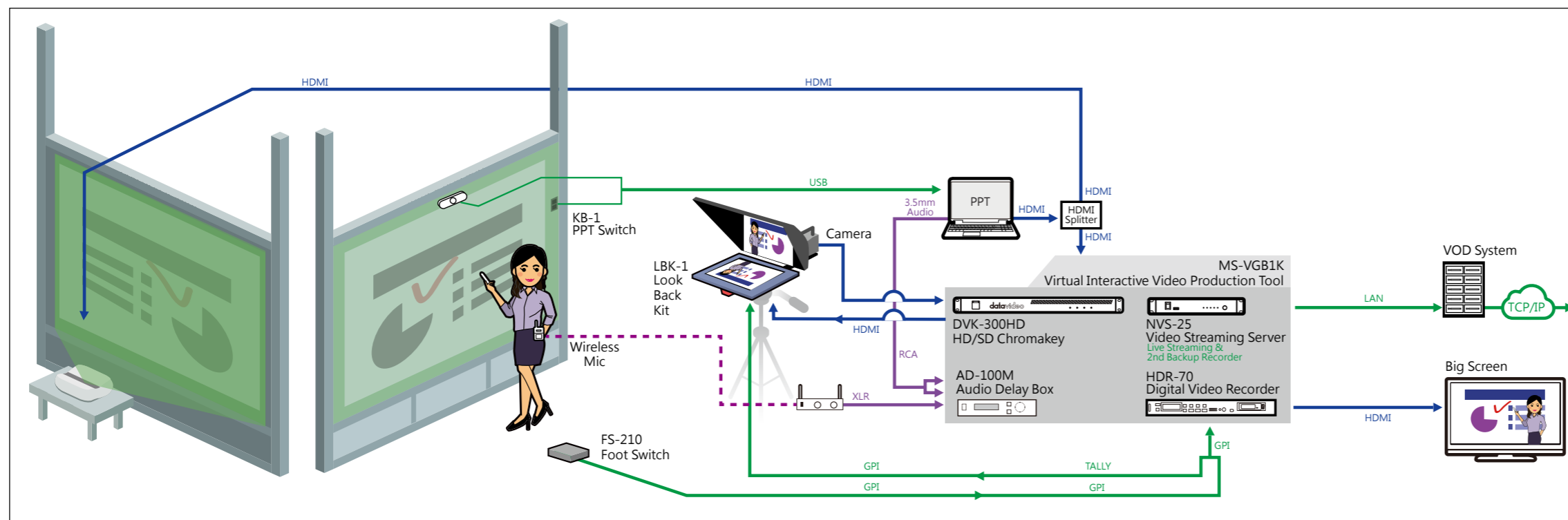

The VGB-1000R rear projection Virtual Electronic Green Board System projects PPT or the desired images onto the rear side of a green screen. The screen can be as large as 120 inch. Once linked with the interactive electronic pen, the talent will then be able to write on the board and talk at the same time. Not only that, the entire VGB-1000 Virtual Electronic Green Board System is easy-to-operate and the look back kit allows you to view what is being recorded. Streaming and recording can be done at the same time, allowing you to perform two jobs simultaneously.

Look Back Kit
LBK-1



LBK-1 allows users to see themselves within the virtual environment and to remain inside the set., there is a tally light indicator below the look back kit, allowing the talent to be aware when the program is recording.

Interactive Electronic Pen
IEPEN



1. Write and draw on PPT slides, flip PPT slides, and virtual buttons for controlling PPT slides.
2. An integrated virtual button for easier operation of PPT slides.
3. Immediate remote sharing of PPT slides.
4. Notes can be kept and stored with the entire lecture recording.

Virtual Interactive Video Production Tool
MS-VGB1K



MS-VGB1K lecture recording system, a 4RU rack integrates the Datavideo DVK-300 HD Chromakey, AD-100M Audio Calibration unit, NVS-25 H.264 Video Stream server, a HD recorder HDR-70 and a Foot Switch remote Controller FS-210.

Real-time Chromakey overlay of the Lecturer and PowerPoint on to the same video, HD live streaming and instant recording controlled by a foot switch, MS-VGB1K makes professional MOOC video production become easy.

Foot Switch
FS-210



The foot switch allows the teacher to start and stop the recording at any time. The foot switch indicator is above the tally light of the lookback kit.

Essential Items					
Model	MS-VGB1K	MAT-5	LBK-1	IEPEN	FS-210
Model Name	Virtual Interactive Video Production Tool	Green Color Plastic Mat 1.8x54m (WxH)	Look Back Kit	Interactive Electronic Pen	Foot Switch
Optional Items					
Model Name	HDMI Camcorder and Tripod	Short throw Projector	LED light sets	22" Look Back Monitor	Preview Monitors

Disclaimers of Product and Services

This brochure is intended as a guide only. We reserve the right to change specifications and availability without prior notice. While we strive for complete accuracy, be aware that it may contain errors and omissions. Prior to purchase, please check with your local Datavideo office or authorised distributor.

datavideo

www.datavideo.com

YouTube



DATAVIDEO WORLDWIDE OFFICES

China Shanghai
Datavideo Technologies China Co
101, NO.618, LiuYing Rd,
Zhabei District,
Shanghai, China
Tel: +86 21-5603 6599
Fax: +86 21-5603 6770
E-mail: service@datavideo.cn

China Beijing
Datavideo Technologies China Co
No. 812, Building B, Wankai Center,
No.316, Wan Feng Road, Fengtai District,
Beijing, China
Tel: +86 10-8586 9034
Fax: +86 10-8586 9074
E-mail: service@datavideo.cn

China Chengdu
Datavideo Technologies China Co
B-823, Meinian square, No.1388,
Middle of Tianfu Avenue, Gaixin District,
Chengdu, Sichuan
Tel: +86 28-8613 7786
Fax: +86 28-8513 6486
E-mail: service@datavideo.cn

China Fuzhou
Datavideo Technologies China Co
A1-2318-19 Room, No.8, Aojiang Road,
Taijiang District, Fuzhou, Fujian, China
Tel: 0591-83211756 · 0591-83210187
Fax: 0591-83211262
E-mail: service@datavideo.cn

France
Datavideo France s.a.r.l.
Cité Descartes 1, rue Albert Einstein
Champs sur Marne 774477 –
Marne la Vallée cedex 2
Tel: +33-1-60370246
Fax: +33-1-60376732
E-mail: info@datavideo.fr

Hong Kong
Datavideo Hong Kong Ltd
G/F., 26 Cross Lane
Wanchai, Hong Kong
Tel: +852-2833-1981
Fax: +852-2833-9916
E-mail: info@datavideo.com.hk

India Noida
Datavideo India Noida
A-132, Sec-63, Noida-201307,
India
Tel: +91-0120-2427337
Fax: +91-0120-2427338
E-mail: sales@datavideo.in

India Kochi
Datavideo India Kochi
2nd Floor- North Wing, Govardhan Building,
Opp. NCC Group Headquarters, Chittoor Road,
Cochin- 682035
Tel: +91 4844-025336
Fax: +91 4844-047696
E-mail: sales@datavideo.in

Netherlands
Datavideo Technologies Europe BV
Floridadreef 106
3565 AM Utrecht,
The Netherlands
Tel: +31-30-261-96-56
Fax: +31-30-261-96-57
E-mail: info@datavideo.nl

Singapore
Datavideo Visual Technology(S) Pte Ltd
No. 178 Paya Lebar Road #06-07
Singapore 409030
Tel: +65-6749 6866
Fax: +65-6749 3266
E-mail: info@datavideovirtualset.com

Singapore
Datavideo Technologies (S) PTE Ltd
No. 178 Paya Lebar Road #06-03
Singapore 409030
Tel: +65-6749 6866
Fax: +65-6749 3266
E-mail: sales@datavideo.sg

Taiwan
Datavideo Technologies Co. Ltd
10F. No. 176, Jian 1st Rd., Chung Ho
District, New Taipei City 235, Taiwan,
R.O.C.
Tel: +886-2-8227-2888
Fax: +886-2-8227-2777
E-mail: service@datavideo.com.tw

United States
Datavideo Corporation
7048 Elmer Avenue.
Whittier, CA 90602,
U.S.A.
Tel: +1-562-696 2324
Fax: +1-562-698 6930
E-mail: sales@datavideo.com

United Kingdom
Datavideo UK Limited
Units 1 & 2 Waterside Business Park
Hadfield, Glossop, Derbyshire
SK13 1BE, UK
Tel: +44-1457 851 000
Fax: +44-1457 850 964
E-mail: sales@datavideo.co.uk