

Operation Manual

DeckLink Series

Blackmagicdesign 

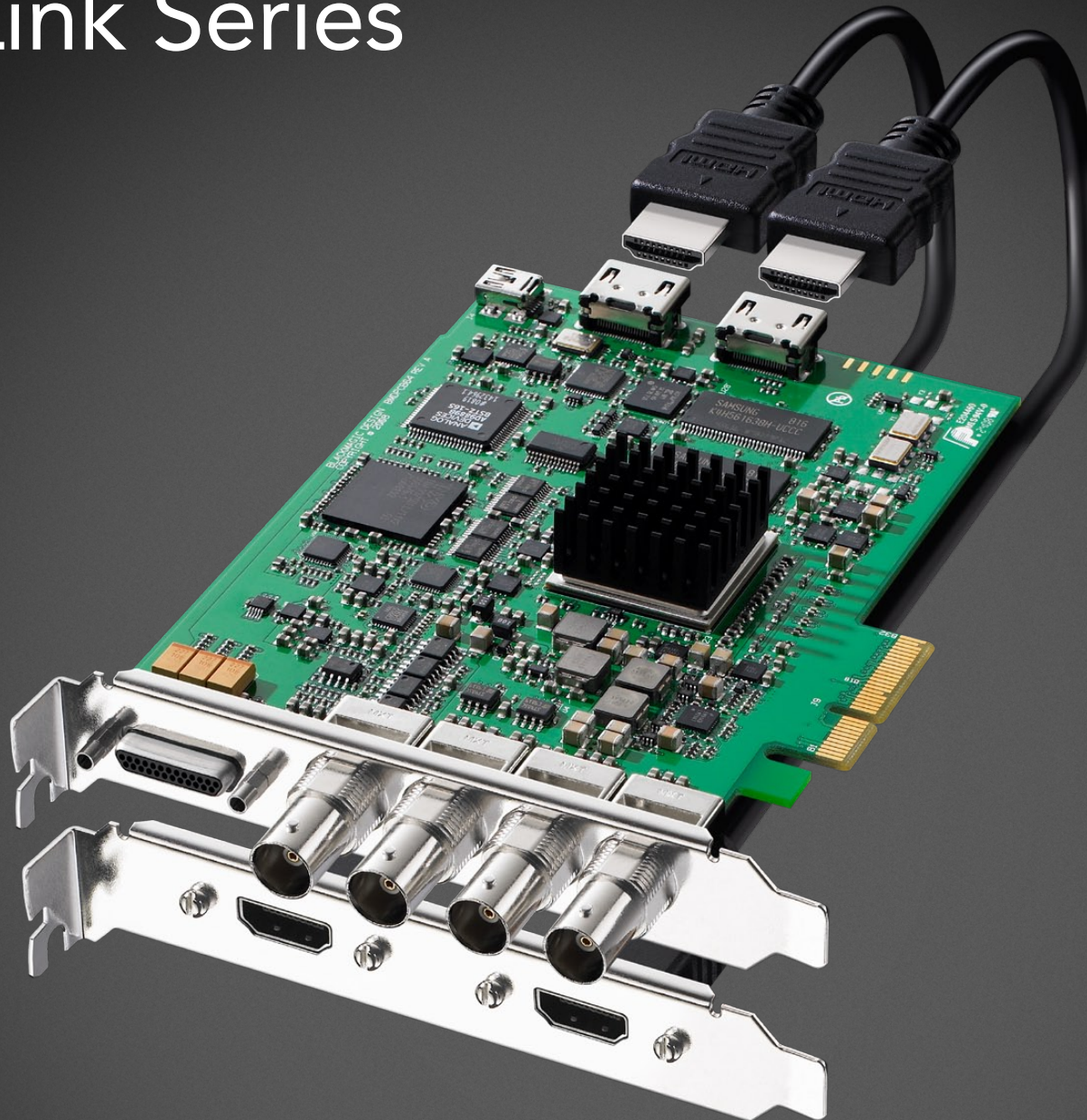

Windows™
February 2009

05 How to use your DeckLink Card

Before installing a DeckLink Card	6
PCI Slots and DeckLink Cards	6
Installation	7
Installing the HDMI bracket	7
Installing the Software	8
Testing your Installation	9
Blackmagic Software	10
Using Blackmagic Media Express	10
Using Blackmagic Framelink	13
Setting Blackmagic Preferences	14
Lookup Tables (LUTs) in DeckLink HD Extreme 2	19
Blackmagic Disk Speed Test	21
Disk arrays	21
Third Party Applications	22
Adobe Premiere Pro	22
Adobe After Effects	24
Adobe Photoshop	25
Supported File Formats	26
Troubleshooting Video Capture and Playback	27

28 Connection Diagrams

Betacam SP analog deck	29
SDI digital deck	30
Sony HDCAM SR deck in 4:2:2 DeckLink HD Extreme 3	31
Sony HDCAM SR deck in 4:4:4	32
NTSC/PAL monitor	33
Connecting to S-Video	34
YUV component monitor	35
Connecting to an HDTV	36
HDMI Workflow	37
Monitoring Via HDMI	38
2K Monitoring with HDLink Pro	39

40 Device Diagrams

DeckLink HD Extreme 3	41
DeckLink SDI	42
DeckLink Studio	43

44 Developer Information

Blackmagic 2K Format Overview	45
Blackmagic 2K Format Table	46

05 How to use your DeckLink Card

Before installing a DeckLink Card	6
PCI Slots and DeckLink Cards	6
Installation	7
Installing the HDMI bracket	7

47 Connection Diagrams

Betacam SP analog deck	48
SDI digital deck	49
Sony HDCAM SR deck in 4:2:2	50
Sony HDCAM SR deck in 4:4:4	52
NTSC/PAL monitor	53
Connecting to S-Video DeckLink HD Extreme 2	54
Connecting to S-Video DeckLink HD Extreme	55
YUV component monitor	56
Connecting to an HDTV	57
HDMI Workflow	58
Monitoring Via HDMI	59
2K Monitoring with HDLink Pro	60

61 Device Diagrams

DeckLink HD Extreme 2 and Professional Breakout Cable	62
DeckLink HD Extreme 2 and Consumer Breakout Cable	63
DeckLink HD Extreme and Professional Breakout Cable	64
DeckLink HD Extreme and Consumer Breakout Cable	65
DeckLink HD Pro PCIe	66
DeckLink HD Pro PCI-X	67
DeckLink Extreme	68
DeckLink Extreme PCIe	69
DeckLink SP	70
DeckLink SP PCIe	71
DeckLink Pro	72
DeckLink	73

74 12 Month Limited Warranty

Warranty Terms and Conditions	75
-------------------------------	----

4 Welcome



Thank you for purchasing a DeckLink broadcast video card.

We hope you share our dream for the television industry to become a truly creative industry by allowing anyone to have access to the highest quality video.

Previously high end television and post production required investment in millions of dollars of hardware, however with DeckLink cards, even 10 bit uncompressed is now easily affordable. We hope you get years of use from your new DeckLink card and have fun working with some of the world's hottest television and design software!

This instruction manual should contain all the information you'll need on installing your DeckLink capture card, although it's always a good idea to ask a technical assistant for help if you have not installed hardware cards into computers before. As DeckLink uses uncompressed video and the data rates are quite high, you'll need fast disk storage and a high-end Mac.

We think it should take you approximately 10 minutes to complete installation. Before you install DeckLink, please check our website at www.blackmagic-design.com and click the support page to download the latest updates to this manual and DeckLink driver software. Lastly, please register your DeckLink when downloading software updates. We would love to keep you updated on new software updates and new features for your DeckLink. Perhaps you can even send us your latest show reel of work completed on your DeckLink and any suggestions for improvements to the software. We are constantly working on new features and improvements, so we would love to hear from you!

Grant Petty

CEO Blackmagic Design

DeckLink Series Operation Manual

How to use your DeckLink Card

6 How to use your DeckLink Card

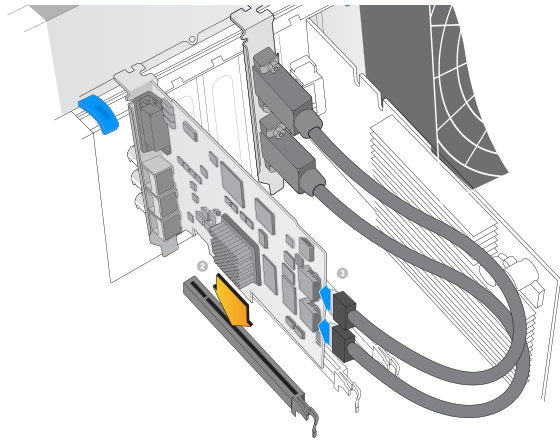

Install a DeckLink PCIe x1 or x4 lane card in a compatible PCI Express slot as shown in the above picture. The DeckLink HD Extreme 3 also has an HDMI bracket, which installs in any spare port, and connects to the rear of the card with the supplied HDMI cables.

Before installing a DeckLink card

1. Remove the power plug from the back of your PC. This is a safety precaution before opening your computer. Ensure that you are statically discharged by using a static strap.
2. Remove the side cover of your PC to gain access to the PCI slots.
3. Remove your DeckLink PCIe card from the protective static bag making sure you don't touch the gold connectors on the base of the card. These precautions should be taken when handling any PCI card.
4. Find a spare PCI, PCI-X or PCIe slot. Remove the metal port access cover, and screw, from the back of your PC.
5. Insert your DeckLink PCIe card and ensure that it clicks into place.
6. Secure the card by the screw or clamping device.
7. The procedure for installing a RAID controller card is similar to the above.
8. Now replace the side cover of your PC. Reconnect the power and start up the computer.

Note: DeckLink standard definition PCIe cards require a x1 lane PCI Express slot or faster. Some DeckLink high definition PCIe cards require a x4 lane PCI Express slot or faster and others only require a x1 lane PCI Express slot or faster. DeckLink HD Pro PCI-X requires a 133MHz PCI-X slot.

Please see www.blackmagic-design.com/support for the latest list of supported motherboards for use with DeckLink cards.

Installing a DeckLink PCIe card

1. Shutdown and remove the power plug from the back of your PC. This is a safety precaution before opening your computer. Ensure that you are statically discharged by using a static strap.
2. Remove the chassis cover of your PC to gain access to the PCI Express slots.
3. Remove your DeckLink PCIe card from the protective static bag making sure you don't touch the gold connectors on the base of the card. Although there are no electronics on this card, these precautions should be taken when handling any PCI Express card.
4. Find a spare PCIe slot within the PC. PCIe x1 lane cards should work in any slot. PCIe x4 lane cards require a x4 lane or faster PCI Express slot. Remove the metal port access cover and screw, from the back of your PC.

7 Installation

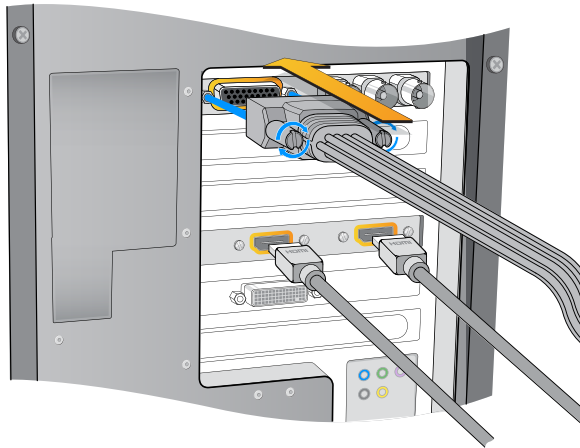

Attach the supplied DeckLink breakout cable to the DeckLink card. The DeckLink HD Extreme 3 card also includes a HDMI bracket as pictured above.

continued from previous page

5. Insert your DeckLink PCIe card and ensure that it clicks firmly into place.
6. Secure the card with the screw and replace the side cover of your PC.
7. After installing your DeckLink PCIe card and closing the side cover on your PC, attach the supplied DeckLink breakout cable to the external multi-pin connector on your DeckLink card. Some card models ship with both professional and consumer breakout cables for connecting to different video hardware. Attach the appropriate breakout cable for your needs.

Installing the HDMI bracket

The DeckLink HD Extreme 3 includes an HDMI bracket. After installing the DeckLink HD Extreme 3 card in a x4 lane PCIe slot, you will need a spare slot to install the HDMI bracket. Some PC's include a double-width graphics slot in the x16 lane slot. If you have a regular-width graphics card in this slot, you can install the HDMI bracket in the spare port which would have been used by a double-width graphics card. If that port is already occupied by a double-width graphics card, use a spare slot to install the HDMI bracket. If you don't need HDMI input and output, there is no necessity to install the HDMI bracket.

Some computer cases provide a PCI clamp which is designed to secure all PCI Express cards without the need for screws. The clamp does not always firmly secure the HDMI bracket and so we have included 6 screws with your DeckLink HD Extreme 3. Use these screws, in place of the PCI clamp, to firmly secure all your PCI Express cards, port access covers and the HDMI bracket belonging to DeckLink HD Extreme 3.

After installing and securing the HDMI bracket, loop the included HDMI cables around any other installed cards and plug them into the rear of the DeckLink HD Extreme 3 card. HDMI input is the lower connector and HDMI output is the upper connector. You may wish to secure any excess cable length by using a cable tie to neatly hold it in place.

Note: Connecting audio and video cables to the DeckLink can be done at any time while the unit is powered on or off. You can leave the PCI Express card in the computer when the PCI Express cable is disconnected. It will then be ready to reconnect quickly when you need to use DeckLink as a capture and playback device again.

Installation

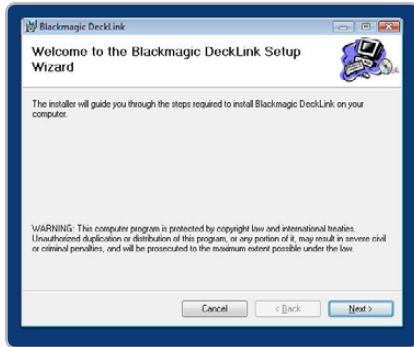

DeckLink Setup Wizard.

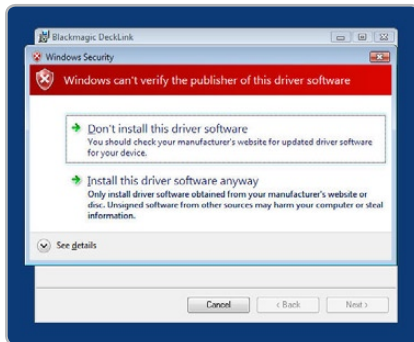

Click "Continue Anyway".

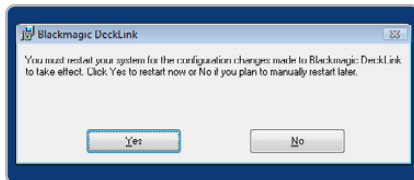

Restart your PC!

Installing the software

Contents

The DeckLink software installer will install the following components for you:

- Blackmagic DeckLink drivers
- Blackmagic Media Express application
- Blackmagic DeckLink Control Panel
- Blackmagic AVI and QuickTime™ codecs
- Project presets for Adobe Premiere Pro
- Blackmagic DirectShow™ SDK
- Blackmagic Disk Speed Test
- Blackmagic FrameLink
- DeckLink Utility

DeckLink software

1. The CD supplied with the DeckLink contains the DeckLink software. Before you install, ensure you have the very latest driver. Visit www.blackmagic-design.com/support
2. Open the "DeckLink Installer" folder and launch the "DeckLink Installer" application.
3. The drivers will now be installed on your system. A warning will appear that "Windows can't verify the publisher of this driver software" or about "logo certification". Click **Continue Anyway** to ignore this warning.
4. You will see a dialog bubble saying "found new hardware" and the hardware wizard will appear. Select "install automatically" and the system will find the required DeckLink drivers. You will then receive another dialog bubble saying "your new hardware is ready for use."
5. Now restart your machine to enable the new software drivers.

Automatic firmware updating

After your computer has restarted, the software will talk to the DeckLink to see what firmware is running in its hardware. If the firmware is not the same as the DeckLink software requires, you'll be asked to download the correct version. This is automatic, and all you need to do is click **OK** to start the update. After the firmware updates, restart your computer and to complete the process.

Programmable firmware let's us release new features and we can also update your DeckLink for greater compatibility with latest third party software tools.

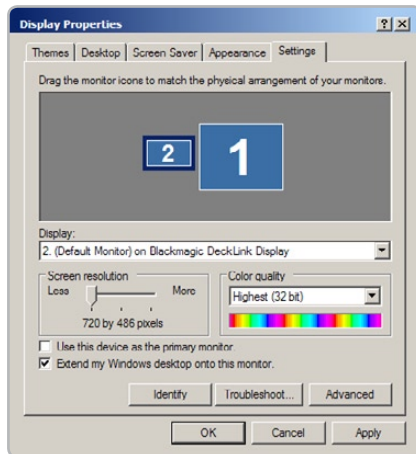

Display Properties.

Testing your installation

Testing

To check the installation has been successful on most DeckLink cards with Windows XP:

1. Go to the Control Panel and open **Display**. Click on the **Settings** tab. You should see an extra display which represents the extended desktop feature of your DeckLink. The size of the DeckLink display will appear differently to your computer display, and may be in HD or SD resolution. Select the second display. DeckLink models, which support high definition video with a x1 lane PCI Express card, do not include an extended desktop and will not show an extra display in the Settings tab.
2. Then enable **Extend my Windows desktop onto this monitor**
3. Go to the Control Panel and open **DeckLink**. Check the SDI, Analog Component, Composite NTSC/PAL, and the HDMI outputs for desktop video.

The DeckLink HD Extreme 3 has SDI, Component analog, Composite analog and HDMI video outputs as well as SDI, HDMI, XLR analog and AES digital audio outputs. Other models of DeckLink cards have some but not all of these video and audio outputs.

Note: You won't see any video on the composite analog NTSC/PAL outputs if the desktop is set to HD or 2K modes. You won't see any video on the component analog outputs if the desktop is set to 2K modes. A 2K monitoring solution, such as HDLink Pro and a 30" monitor, is required to view 2K-SDI video output from hardware such as DeckLink HD Extreme 3 and Multibridge Eclipse.

4. Check audio output channels 1 & 2 for audio playback. The same audio should be heard on all the audio outputs provided on your model of DeckLink card, eg: analog XLR, AES/SPDIF, HDMI and SDI. If this is all working well, you know your DeckLink is working correctly.

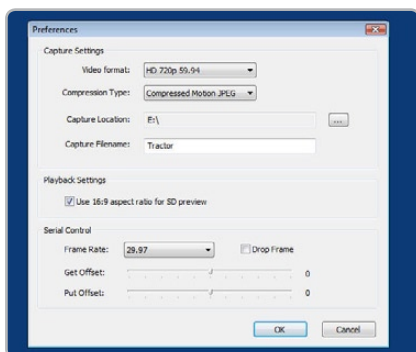

Media Express preferences.

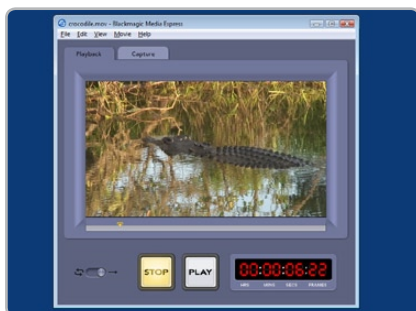

Media Express interface.

Using Blackmagic Media Express

Blackmagic Media Express is a simple utility for frame-accurate capture and playback with your broadcast tape deck. It uses the RS-422 port on DeckLink and DeckLink hardware to control the deck using the Sony™ RS-422 protocol.

It's great for use with applications such as Adobe After Effects™ and eyeon Fusion™ which do not include their own deck control capabilities.

Blackmagic Media Express supports capture and playback of AVI files in the following Blackmagic formats:

- Uncompressed 10-bit RGB (.avi)
- Uncompressed 10-bit YUV (.avi)
- Uncompressed 8-bit YUV (.avi)
- Compressed Motion JPEG (.avi)

Playback of the following formats is also supported:

- Windows Media Video (.wmv)
- Blackmagic QuickTime Uncompressed 10-bit RGB (.mov)
- Blackmagic QuickTime Uncompressed 10-bit YUV (.mov)
- Blackmagic QuickTime Uncompressed 8-bit YUV (.mov)

Playback of other video formats is likely to work as long as the relevant codec is present on the computer and the video is in a standard TV resolution and frame rate, eg 720 x 486 at 29.97 fps. Computer resolutions such as 640x480 cannot be used. Audio must use the television standard sample rate of 48Hz and 24 bit.

This simple utility can capture or play back one video clip at a time. **Put Clip**

Setting Up

1. Go to the Windows Start menu and select **All Programs > Blackmagic Design > DeckLink > Media Express.**
2. Open **Edit > Preferences** and select the desired video format and compression type from the drop down menu.
3. Set your disk array as the Capture Location and enter a Capture Filename to apply to any captured clips or frame grabs.

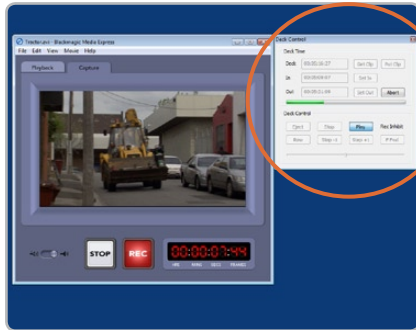

Media Express "Capturing to Disk".

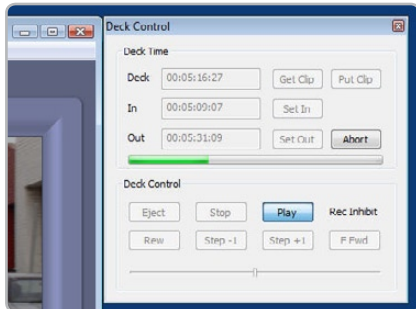

Deck Control interface.

Using Blackmagic Media Express

Playback

1. Click on the Playback tab.
2. Select **File > Open Media File** and choose the video file you wish to play back. Alternatively drag the desired video clip directly in to the Playback window. The movie will appear in the Playback window.
3. Click the Play and Stop buttons to start and stop playback. You can also use the standard keys used for video playback to start, stop, play forwards and play backwards at different speeds, i.e. "<spacebar>", "j", "k" and "l" keys.
4. You can also scrub the clip by dragging the playhead along the timeline.

Video playback can be set to loop playback, or play once, by setting the playback switch as desired.

Inserting to Tape

1. Connect an RS-422 cable between the video deck and the DeckLink or DeckLink RS-422 port to ensure that timecode is available.
2. Open the clip that you wish to print to tape.
3. Ensure that the video deck is configured to accept the video format of the clip, e.g. one cannot send a PAL clip to an NTSC-only deck.
3. From the View menu choose Deck Control. The Deck Control window will open.
4. Enter the timecode of the desired in-point. Blackmagic Media Express will use the clip duration to automatically calculate the out point.
5. Click Put Clip.

Capturing Clips

1. Click on the Capture tab
2. Connect an RS-422 cable between the video deck and the DeckLink or DeckLink RS-422 port to ensure that timecode is available.
3. Go to the Edit menu and choose Preferences.
4. Configure the capture settings to match the video format and compression type you intend to capture, e.g. HD 1080i 59.94 and Uncompressed 10-bit YUV. Set the capture location. Uncompressed video should always be captured to a disk array.
5. Click Put Clip.

There are two ways to capture clips:

A. Record Now

Captures video and audio instantly. (Control-R)

The REC button lights up during capture. Click the STOP button or press the Esc key on your keyboard to stop the capture.

B. Get Clip

Captures frame accurate timecode, video, audio to "in" and "out-points" set by the user.

From the View menu choose Deck Control. The Deck Control window will open.

Connect an RS-422 cable between the video deck and the DeckLink or DeckLink RS-422 port to ensure that timecode is available.

Click the Play and Stop buttons in the Deck Control window to start and stop playback of the video deck. Your video deck will respond to the standard keys used for deck control, i.e. spacebar, "j", "k" and "l" keys. In and Out points can be set using the "i" and "o" keys while playing the tape.

Grab Frame

Captures a frame of video from the video input.

1. Click on the Capture tab
2. Go to the Movie menu and choose Grab Frame As. (Control-G)
3. The frame grab will be captured as a .bmp file.

13 How to use your DeckLink Card Blackmagic Software

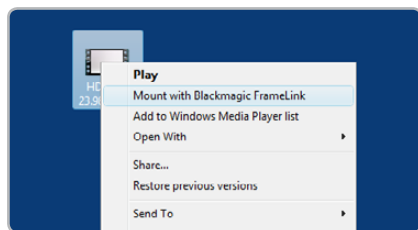

Mounting FrameLink volume.

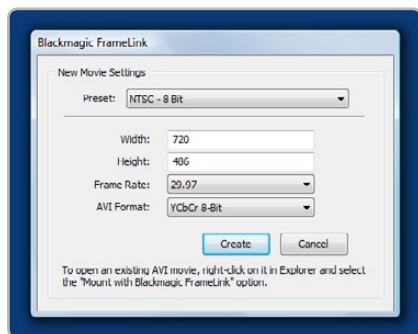

New FrameLink movie.

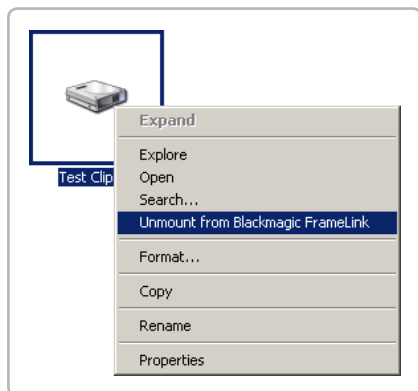

Unmounting FrameLink volume.

Using Blackmagic FrameLink

Blackmagic FrameLink™ provides seamless DPX support using uncompressed AVI movies.

The key to understanding FrameLink, is when you mount a movie file with FrameLink it appears as a virtual drive full of DPX frames from the movie. This virtual drive acts as a container for the DPX sequence. Any frames modified will be automatically written back into the movie when the frame is saved.

FrameLink totally eliminates the time wasted using simple movie to image-sequence conversion utilities. FrameLink is great for using software that only supports still frames, or simply open individual media file frames in Photoshop™ for dirt and scratch removal, then save the frames back into the movie file for instant playback. If an audio track is included with the media that you are converting to a DPX sequence, the length of the sequence cannot be modified. To add and remove DPX frames from a sequence, the audio tracks should be removed and restore later in your NLE.

Supported File Formats

Windows AVI and Blackmagic™ uncompressed QuickTime™ files can be used with FrameLink, including 8-bit & 10-bit YUV HD and SD, as well as 10-bit RGB 4:4:4 HD.

Mounting a FrameLink Volume

1. Right click on an AVI file and select **Mount with Blackmagic FrameLink**

The newly mounted drive will appear as next available drive letter. This volume will contain all the frames of the AVI movie in DPX format.

Creating a New Movie from DPX Files

1. Right click on the work area and select **New > Blackmagic FrameLink Movie** and format. (Matching the format of your existing DPX sequence.)

Note: New movie will appear both as a new network drive and as a file.

2. Copy the DPX file sequence to the appropriate drive letter.

Note: You can save your DPX files from any application to the FrameLink volume, or simply drag and drop the files into the FrameLink volume.

Unmounting a FrameLink Volume

1. Deselect network drive.
2. Right click drive letter and select **Unmount from Blackmagic FrameLink**

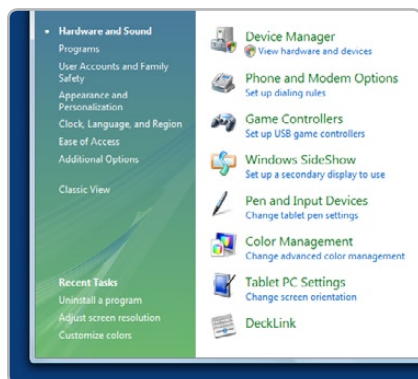

Control Panel.

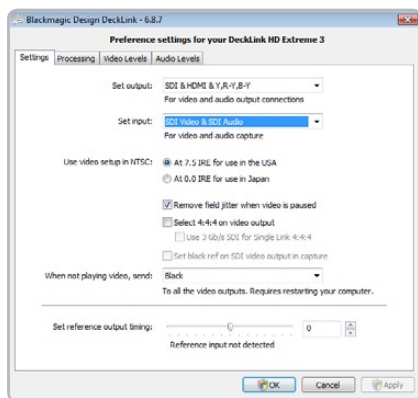

DeckLink Control Panel.

Setting Blackmagic Preferences

DeckLink preferences are located in the DeckLink Control Panel. Different DeckLink models have some different features. Any preferences not available to your DeckLink card will be grayed out and unavailable. The following preferences contain options for setting up your DeckLink.

Settings

- Input and Output connections
- NTSC Setup
- Field Jitter
- 4:4:4 color mode
- Black reference output during capture
- DeckLink Extended desktop
- Reference Output Timing (Genlock)

Processing

- Down conversion
- Up conversion
- Lookup Table
- VITC Reader A Frame - 3:2 Pulldown Removal
- VANC input

Video Levels

- Calibrate Analog Video In
- Calibrate Analog Video Out
- Betacam/SMPTE level switch

Audio Levels

- HiFi/Professional Audio Levels
- Analog Audio Input Levels
- Analog Audio Output Levels
- AES/EBU Input Reference Level
- AES/EBU Output Reference Level

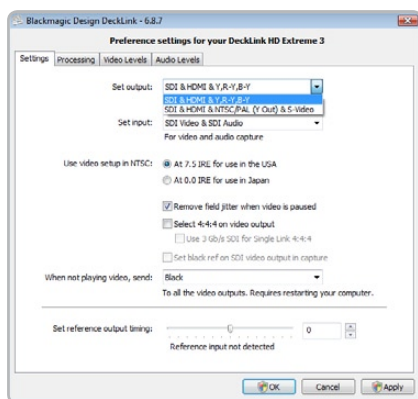

Video and Audio Output Connections.

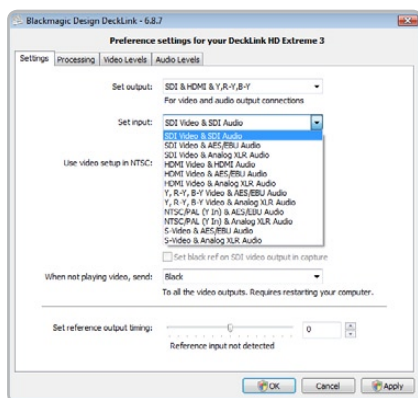

Video and Audio Input Connections.

Setting Blackmagic Preferences

DeckLink video and audio output connections

All of the video and audio outputs of DeckLink cards are active all of the time and the only choice you need to make on some models is between component (Y,R-Y,B-Y) analog video, S-Video or composite NTSC/PAL analog video as they use shared connectors.

The SDI, HDMI and component (Y,R-Y,B-Y) analog video outputs support HD and SD video. S-Video and composite analog video do not support high definition video and so you will not see video on these outputs when working with HD video.

S-video is supported on some HD models of DeckLink cards and may require the use of an inexpensive S-video adapter cable. See the connection diagrams for S-video towards the end of this manual.

DeckLink Studio switchable audio outputs

The DeckLink Studio has switchable audio outputs. You can choose to output:

- 4 analog and 2 AES/EBU audio channels, or
- 2 analog and 6 AES/EBU audio channels

DeckLink video and audio input connections

Your DeckLink model may support some or all of the following combinations:

- SDI Video & SDI Audio
- SDI Video & AES/EBU Audio
- SDI Video & Analog XLR Audio
- HDMI Video & HDMI Audio
- HDMI Video & AES/EBU Audio
- HDMI Video & Analog XLR Audio
- Y, R-Y, B-Y Video & AES/EBU Audio
- Y, R-Y, B-Y Video & Analog XLR Audio
- NTSC/PAL (Y In) & AES/EBU Audio
- NTSC/PAL (Y In) & Analog XLR Audio
- S-Video & AES/EBU Audio
- S-Video & Analog XLR Audio

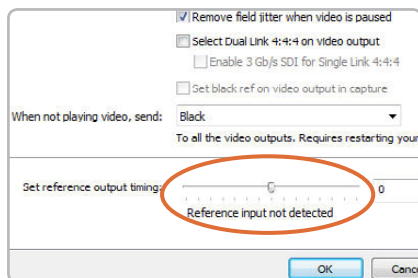

Genlock timing adjustment.

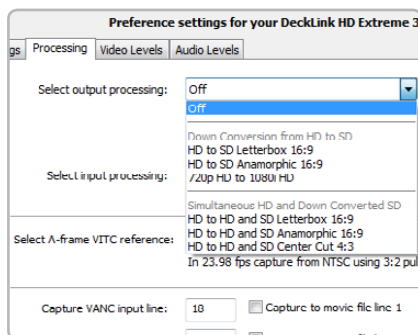

HDTV Up/Down Converter preferences.

Setting Blackmagic Preferences

Reference Output Timing

Genlock, also known as black burst, reference or house sync is used to lock various equipment in your facility to the same timing point. When two or more video devices are connected to the same sync signal, their video signals can be switched without jumping or rolling. This is critical when connecting equipment in large post production facilities and broadcast stations.

To change video to reference timing:

1. Open the **DeckLink** control panel.
2. Select the **Settings** tab and adjust the **Set reference output timing** for timed output until the picture locks and is no longer rolling on the display.

HDTV Up/Down Conversion

The software drivers included with DeckLink, can be used to downconvert high definition to NTSC or PAL video in real time during capture or playback. They also provide upconversion on capture. Select the desired option from the output or input processing menus under the Processing tab.

Output Processing

- HD to SD Letterbox 16:9
- HD to SD Anamorphic 16:9
- 720p HD to 1080i HD

Output Processing for DeckLink cards with permanent downconversion.

- HD to HD and SD Letterbox 16:9
- HD to HD and SD Anamorphic 16:9
- HD to HD and SD Center Cut 4:3

Note: Permanent down conversion introduces a 2 frame delay on the SD-SDI output. To ensure accuracy, adjust the playback/timecode offset options when performing an insert or assemble edit to tape with Premiere Pro or Blackmagic Media Express.

Input Processing

- 1080i HD to SD Letterbox 16:9
- 1080i HD to SD Anamorphic 16:9
- 720p HD to SD Letterbox 16:9
- 720p HD to SD Anamorphic 16:9
- SD Letterbox 16:9 to HD
- SD Anamorphic 16:9 to HD

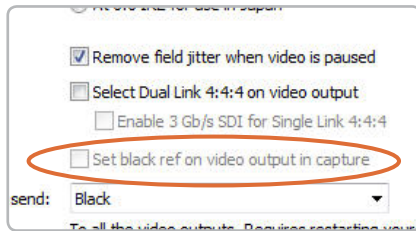

Black Video Output.

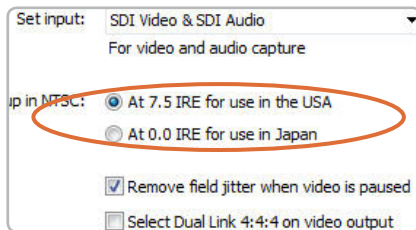

NTSC Setup.

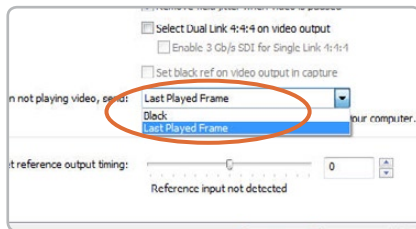

Video Desktop.

Setting Blackmagic Preferences

Black Video Output

This setting allows DeckLink to output a stable black signal on one video output, while outputting video on the other output. Black Video Output is used for video referencing a deck when you don't have a sync generator available. This allows the stable black video output to connect to the deck, and then by setting the deck to "input reference" you can operate without a sync generator. If you're not using this mode, disable this setting to enable audio monitoring during capture.

NTSC setup

The NTSC composite video used in the USA, and some other countries uses 7.5% setup. However setup is only used in composite video, but is never used in SDI video. Your DeckLink will handle adding and removing setup from NTSC video automatically for you. The USA and countries that use 7.5% setup should enable this setting; if you're working in Japan and countries that don't use this setup, leave this set to 0 IRE setup. The PAL and high definition standards do not use this setup.

Video Desktop

If your DeckLink card includes the extended desktop feature, this setting allows DeckLink to act as a display device with the desktop appearing out of the video outputs. This setting allows the desktop mode to be turned on and off and any change requires a restart. It's important that you set the desktop mode to the same standard as your video capture and playback, or you will get slower switching between capture and playback modes, as the monitors need to re-lock.

If you don't want to use the Extended Desktop feature, set this option to Black and then restart the computer.

If you're adjusting LUT's on some DeckLink models, set this option to Last Played Frame so you can observe the effect of any adjustment to LUT's.

The video desktop feature is supported in Windows XP™. It is not available in Windows Vista™.

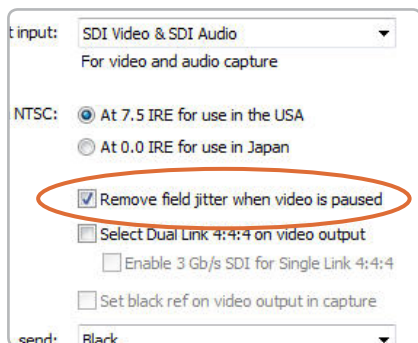

Video Output Behavior.

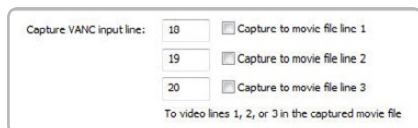

VANC preferences.

Setting Blackmagic Preferences

Video Output Behavior

Remove Filter Jitter

“Remove field jitter when video is paused” allows DeckLink to display only a single field when paused, while turning this mode off will display a complete frame in pause. Single field is similar to how Betacam SP decks work when paused, eliminating field flicker from paused images.

If you’re doing work without interlaced video, such as animation, then you can turn this mode off so you can see both fields in full resolution for best quality. Regardless of this setting, you always get the correct full frame dual field output when in playback mode, as this setting only effects paused video.

Preserving Blanking Data or VANC

This feature lets you use up to 3 video lines at the top of a captured movie file to store any 3 lines from vertical blanking. This allows 3 line timecode, VITC (vertical interval test signals) subtitle info or any other VANC data to be preserved during capture. These lines are then inserted back into the video blanking when the file is played back.

To preserve VANC data:

1. Open the **DeckLink** control panel.
2. Select the **VANC and 3:2 Pulldown** tab and tick the **On** check box for video line 1, 2 or 3 depending on how many blanking lines you want to capture.

Note: Video file line 1 needs to be enabled for lines 2 and 3 to work.

Because these lines can be passed to the application, a developer could write software to read the VANC data and use it for various purposes, e.g. 3-line timecode and audio chasing, or other uses.

An example of VANC data is 3-line timecode, which uses lines 18, 19, and 20 in NTSC or lines 19, 20 and 21 in PAL. 3-line timecode, as used in AATON™ equipped telecine suites, featuring audio timecode and keycode information along with the normal timecode numbers.

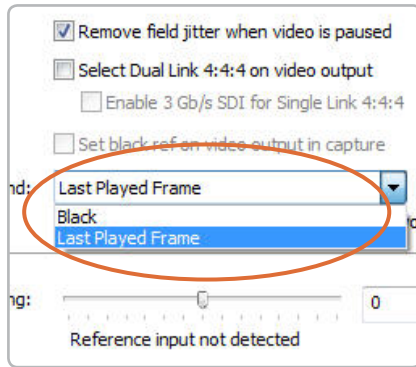

Enable Last Played Frame.

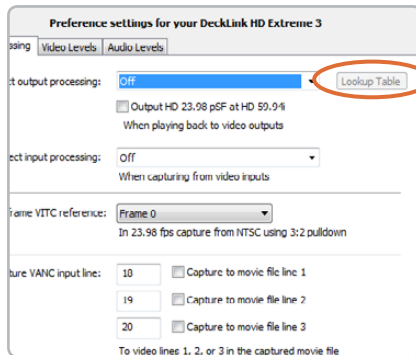

Click on the Lookup Table button.

Lookup Tables (LUT's) in DeckLink HD Extreme 2 for Windows

DeckLink HD Extreme 2 can use 1D or 3D LUT's during playback. Lookup tables can be used for standard definition and high definition video as well as 2K film.

1D LUT's are useful for altering the brightness of an image but do not affect color. They are often used when working with log video so that the image can be displayed on screen as normal linear video. Built-in 1D LUT's are provided for log to linear conversion when playing video captured from Panasonic Cinegamma™ and Viper Filmstream™ cameras.

3D LUT's provide the ability to increase and decrease the amount of color in each color channel, independently from brightness. This allows for precise color grading to ensure a video monitor matches the color printed to tape or film.

How to use Lookup Tables in DeckLink

When the System Preferences are opened to access the DeckLink lookup table settings, your broadcast monitor will usually stop showing any video being played and instead will show an extended desktop. It is possible to replace the extended desktop, with the last played frame of video, so that adjustments to lookup tables can immediately be seen on the frame of video.

To use this feature, open the DeckLink Control Panel. Under the Settings tab, look for, "When not playing video, send ... to all the video outputs." This setting is usually set to Extended Desktop or Black depending upon your personal preference. Switch it to "Last Played Frame" and then restart the computer.

After the computer has restarted, use your preferred video software application to play some video. The last played frame of video should remain on your broadcast monitor. Open the DeckLink Control Panel and then click on the Processing tab. A Lookup Table button is available for output processing and this can be used even when all other processing functions are set to "Off". Click on the output Lookup Table button and then activate the Enable Lookup Tables checkbox.

The lookup table interface in DeckLink can be adjusted using a method similar to that used for image adjustment with the Curves feature in Adobe Photoshop™. The horizontal axis of each graph represents the original color input values and the vertical axis represents the new colour output values. When first opened, each lookup table displays a straight diagonal line because the color values have not yet been changed.

Changes made to the lookup tables can immediately be seen on all SDI, analog and HDMI outputs of the DeckLink card. Changes are saved to the DeckLink preferences by clicking the OK button. Lookup tables can be reset to original values by clicking the Reset Unity button. Lookup table processing can be disabled by deselecting the Enable Lookup Tables checkbox.



Load Lookup Table from File.

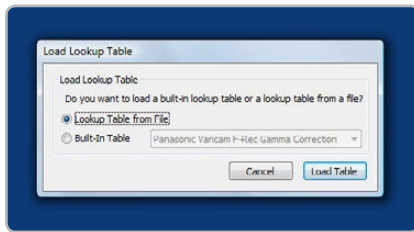

Load Built-In Lookup Table.



Lookup Table interface.

Importing and exporting 3D LUT's

DeckLink HD Extreme 2 supports the popular Autodesk .3dl, IRIDAS .itx and IRIDAS .cube lookup table formats when importing 3D LUT's.

3D LUT's can also be exported from DeckLink in the .cube format. DeckLink uses the .cube format to store 3D LUT's internally as this is a most memory efficient way to store complex lookup tables. Both 3D LUT's created with curves in the lookup table interface, and 3D LUT's imported from .3dl, .itx and .cube files, are exported from DeckLink in the .cube format.

The .cube file format is fully compatible with the following Blackmagic Design products which share the same LUT format: DeckLink HD Extreme 2, DeckLink Eclipse, DeckLink Pro (October 2007 model) and HDLink Pro.

Importing and exporting 1D LUT's

DeckLink HD Extreme 2 can import 1D LUT's. The 1D file format is any tab-delimited text file with red, green and blue values for each record and the first line (title line) is skipped. Lookup tables need to be 1024 records long with the first line reserved for the title line.

1D LUT's can also be exported from DeckLink HD Extreme 2 in the same text format mentioned above. Both 1D LUT's created with the curves in the lookup table interface, and 1D LUT's imported from text files, are exported from DeckLink in the same text format.

The 1D LUT text file format is fully compatible with the following Blackmagic Design products which share the same LUT format: DeckLink HD Extreme 2, DeckLink Eclipse, DeckLink Pro (October 2007 model), DeckLink Extreme (DVI output), HDLink Pro, HDLink and DeckLink HD Pro 4:4:4 (PCI-X).

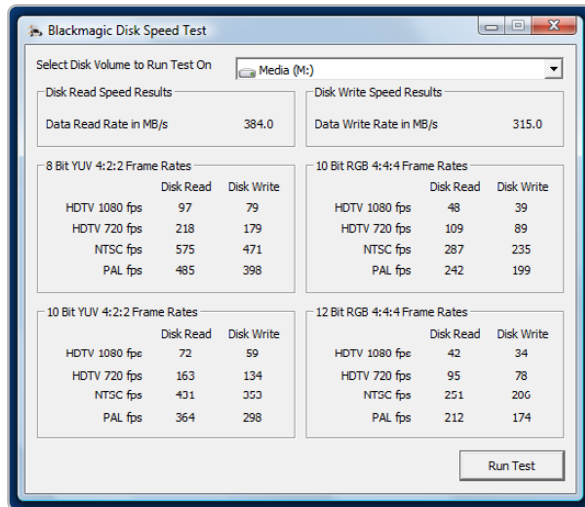

Disk Speed RAID results after testing a disk array.

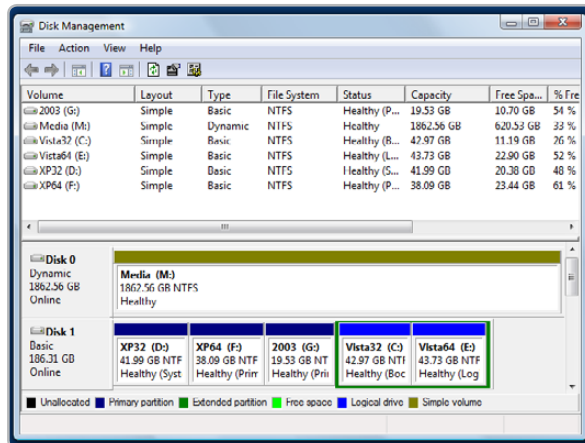

Disk Management.

Blackmagic Disk Speed Test

If you want to check your disk array speed, Blackmagic Disk Speed Test can be run to check the array speed, and to provide the results in video frame rates. This makes it much easier to understand how various disk arrays will handle video capture and playback at various video resolutions and frame rates.

Disk Speed Test provides more accurate results for large disk arrays, as often the manufacturer provided speed results only check small data blocks; so you only get an indication of the cache speed of the disk and not the sustained data rate of the disk. Video uses sustained data rates and only Disk Speed Test provides a long burst of data for more accurate results.

When using Disk Speed Test, you need to account for disk seeking, so it's best to add a healthy margin to the results. If a disk array tests at 32 frames per second HD 1080, it doesn't mean you can do 29.95 HD capture and playback, as the margin is too tight. However it should do 24 fps ok.

Disk arrays

If you intend to run your disk array as a software stripe, you will need to make sure that 'host RAID' is disabled. Use the "Disk Management" tool in "Computer Management" within Windows™ to set up your software RAID, or refer to third party instructions when using pre-configured hardware RAID.

Further information can be obtained via the Windows™ Help and Support. Search and review the section on "Dynamic Disks". This section will provide you with information on how to convert a basic disk to dynamic disk and configuration steps on striping your disk array.

22 How to use your DeckLink Card Third Party Applications

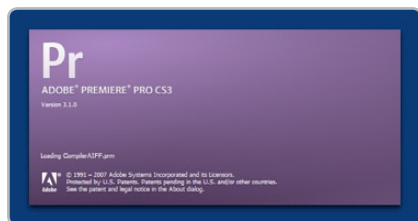

Adobe Premiere Pro.

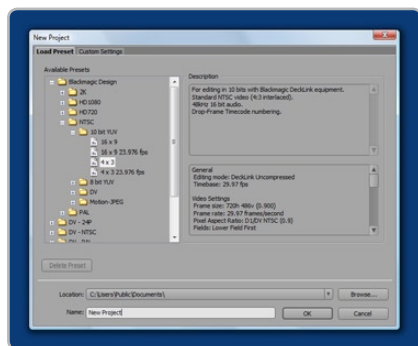

New Project.

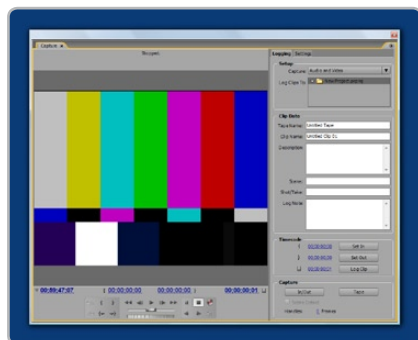

Capture.

Adobe Premiere Pro

Adobe Premiere Pro™ is a powerful real-time video and audio non-linear editing application. Full presets for Premiere Pro are included with DeckLink and will have been automatically loaded into your system during the installation process. Premiere Pro must be installed on your system before running the DeckLink installer.

Setting Up

1. Launch Premiere Pro.
2. Open a **New Project**
3. Select the appropriate Blackmagic preset for your project. e.g. **NTSC**, **PAL**, **HDTV** or **2K**.
4. Type the name of your project.
5. Select your disk array as the location for your media and click **OK**

Playback

As a quick test to make sure everything is connected correctly, use the Premiere Pro test media (bars and tone). Copy a test clip, which matches the format of your project to your disk array e.g. NTSC 8 bit. Take your media from within your Premiere Pro project and drop it into the timeline. You should now see the image on both your computer desktop and your DeckLink output. If you can't see any video on your DeckLink output, check the connections again and ensure you have the correct output settings configured in both the DeckLink and Displays control panels. SDI, HDMI and analog outputs are always active.

Capture

To capture choose: **File > Capture** (F5)

To immediately capture, click the red record button [G]. If you wish to log the clip, enter the desired "In and Out points" using either the "In" and "Out" buttons, or manually, by typing in the timecode and clicking "Log". The empty clip will now appear in the bin window. Repeat this until you have logged all of the clips you wish to batch capture.

Batch Capture

Select the clips you wish to capture by drag selecting or shift/click each clip.

Then go to and choose: **File > Batch Capture**. To set handles on the clips go to the batch capture window menu and type the number of additional frames you require at the start and end of each clip.

23 Third Party Applications

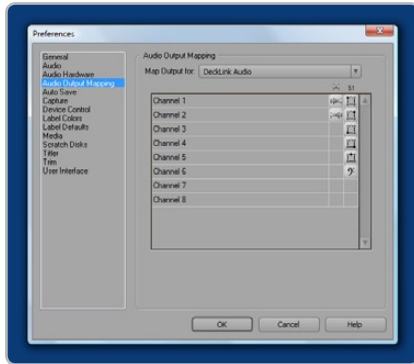

Audio Output Mapping.

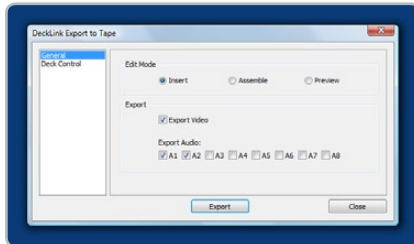

Export to Tape.

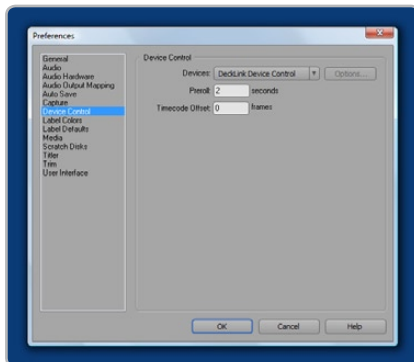

Device Control.

Adobe Premiere Pro

Audio

DeckLink features support for ASIO audio output drivers. This allows Premiere Pro to use DeckLink as an ASIO audio output device. When you first start your Premiere Pro project, make sure you select DeckLink Audio. This can be configured through **Edit > Preferences > Audio Hardware**

You can also select the mix of the multi-channel audio from the Audio Output Mapping menu.

Export to Tape

To export to tape, select the sequence you require **File > Export > Export to Tape**

Insert editing requires an unbroken timecode over the full length of the project you're laying to tape. This is referred to as "blacking the tape".

In **assemble mode** the tape needs only to be "blacked" until a point just beyond the start time of the project. As **assemble editing** erases the tape ahead of the record heads, it should not be used where other projects already exist on the tape after the out point of your edit.

When editing to tape, the software waits at the first frame of your program for the deck to drop into record at the predetermined timecode. At that exact moment, the program begins to play and the edit is completed. Should you find that either the first frame of your program is repeated or lost during the edit to tape procedure you will need to adjust the playback offset to bring the deck and your computer into sync. You should only need to do this once with any combination of deck and computer – and the setting will then stay correct.

Now, simply enter the desired in point and offsets if required, and click **OK**

Device Control

Selection of the Serial Device Control is configured via:

Edit > Preferences > Device Control

Set the Device Control to **DeckLink Device Control**. The Options button is disabled as these settings are automatically detected and configured when you choose DeckLink Device Control.

24 How to use your DeckLink Card Third Party Applications

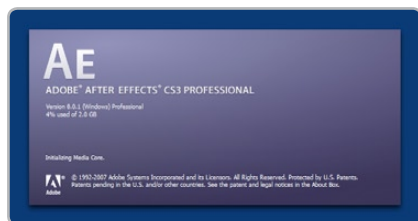

Adobe After Effects.

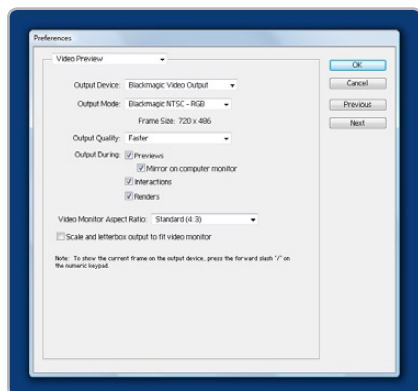

Video Preview preferences.

Adobe After Effects

It's very easy to setup playback and rendering in Adobe After Effects™ for a complete broadcast and design workstation that connects direct to decks for capture and playback of clips. DeckLink also supports real time preview while working on your compositions.

First, open Adobe After Effects™ and select the television standard frame size and frame rate you wish to work with.

How to use DeckLink as a Preview Output Frame Buffer

To allow your Adobe After Effects™ composition to be displayed in real-time from your DeckLink Card, go to **Edit > Preferences > Video Preview**. Set the Output Device to **Blackmagic Video Output** and then select the desired Blackmagic RGB output mode. This lets you view your Adobe After Effects™ compositions in video colorspace on your broadcast monitor as you work. This means you will always see the correct color and interlace when working, and you don't have to wait until your composition is rendered to see what it looks like when output as video.

Create a New Composition

Go to the "Composition" menu and select **Composition > New Composition** (Control + n) In the dialogue box, select an appropriate television standard from the pulldown menu. Click **OK**

- For NTSC 720 x 486, select lower field first
- For PAL 720 x 576, select upper field first for uncompressed video
- For PAL DV, select lower field first
- For HD 1080i select 1920 x 1080, select upper field first
- For HD 1080 PsF select 1920 x 1080, select No Fields
- For HD 720p select 1280 x 720, select No Fields

Rendering

When you have completed your composition, you will need to render to a pixel format supported by DeckLink. Below is a list of supported codecs:

- Blackmagic QuickTime™ RGB (10 bit uncompressed)
- Blackmagic QuickTime™ (10 bit uncompressed)
- Blackmagic QuickTime™ (8 bit uncompressed)
- Apple QuickTime™ PhotoJPEG (compressed)
- Apple QuickTime™ DV - NTSC (compressed)
- Apple QuickTime™ DV - PAL (compressed)

25 Third Party Applications

How to use your DeckLink Card

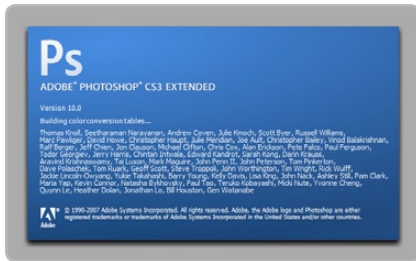

Adobe Photoshop.

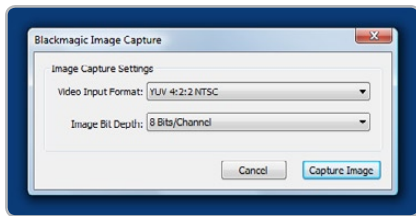

Image Capture.

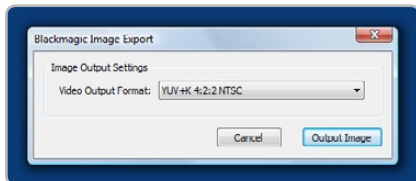

Image Export.

Adobe Photoshop

DeckLink includes Adobe Photoshop™ plug-ins, so you can directly capture and output still frames from within the Photoshop™ application itself.

If you're working with 10 bit HD/SD-SDI, you can even import and export 16 bit Photoshop™ images for full quality. Use DeckLink keying to export and key graphics from the video input using Photoshop™ alpha channels.

Import an image into Photoshop

1. From Photoshop select **File > Import > Blackmagic Image Capture**
2. Select the "Video Input Format" and the "Image Bit Depth" and select **Capture Image**.

Export an image from Photoshop

1. Select **File > Export > Blackmagic Image Export**
2. Select **Video Output Format** and then **Output Image**.

Note: Once you have set the options in the "Export" window, each subsequent Export will not display the window so you can output frames much faster. However, if you would like to change your export formats, hold the **Ctrl** key when selecting export.

Uncompressed data rates for capture and playback

The data rates for uncompressed video are quite high, and listed below are minimum recommended disk requirements for uncompressed standard definition and high definition video.

Uncompressed 10 bit YUV (4:2:2)			
Standard Definition			
Frame Size	MB per second	MB per minute	GB per hour
720x486/29.97fps	27	1 600	94
720x576/25fps	26	1 582	93
High Definition			
1280x720p/60fps	141	8 438	494
1920x1080/24PsF	127	7 594	445
1920x1080/50i	132	7 910	463
1920x1080/60i	158	9 482	556
Uncompressed 10 bit RGB (4:4:4)			
High Definition			
1280x720p/60fps	211	12 656	742
1920x1080/24PsF	190	11 391	667
1920x1080/50i	198	11 865	695
1920x1080/60i	237	14 238	834

Due to disk seeks, when calculating the data rates required for your disk system, it is a good idea to add a safety margin due to fluctuations in disk speed. Disk speeds can be increased by adding more disks.

Serial ATA (SATA) disks can reduce to half their speed as they become full, so in a 2-disk SATA array you should aim for a 100% safety margin. In an 8-disk SATA array, a 30% safety margin should be adequate. SCSI disk arrays seem to display less fluctuation and so a 20% safety margin should be adequate for an 8-disk SCSI array. Generally the more disks in the array, the better.

Note: Although other vendors and third parties may provide different data rates for uncompressed video, the above recommendations are tested for use with DeckLink.

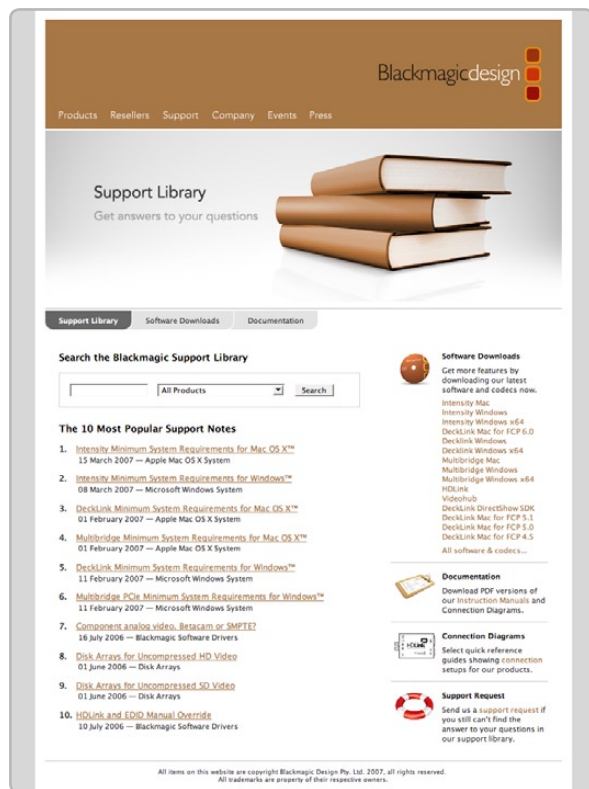

Using your DeckLink as a capture and playback solution when connected to a computer is exciting, but also complex due to the huge range of different software applications. Video data rates are also very high, so the disk array you use for video storage can have a big impact on your system's performance.

Information about a wide range of disk array solutions and compatible application software would be outside the scope of this manual, however there are three ways to get more information.

There are four steps to getting help.

1. Check out the Blackmagic Design website www.blackmagic-design.com/support for the latest support information. We have a huge number of technical notes covering all the common questions we are asked.
2. Call your reseller. Your reseller will have the latest technical updates from Blackmagic Design and should be able to give you immediate assistance. We also recommend you check out the support options your dealer offers as they can arrange various support plans based on your workflow requirements. Your reseller will also understand your disk array configuration, and as disk array problems account for around 90% of support questions with NLE systems, your reseller or disk array vendor will be able to provide expert help.
3. The next option is to email us with your questions using the web form at <http://www.blackmagic-design.com/support/contact>
4. Phone a Blackmagic Design support office. Please check our web site for current support phone numbers in your area. <http://www.blackmagic-design.com/company/>.

Note: Please provide us with as much information as possible regarding your technical problem and system specifications so that we may try to reproduce your problem quickly. Also please let us know how to reproduce any problem you're having, so we can try it on our test systems before replying to your email.

DeckLink Series Operation Manual

Connection Diagrams

29 Connection Diagrams

Connecting to a Betacam SP analog deck

This example shows DeckLink HD Extreme 3 connected to an analog deck for capture and playback to the deck. The HDMI and SDI outputs can be used for local monitoring.

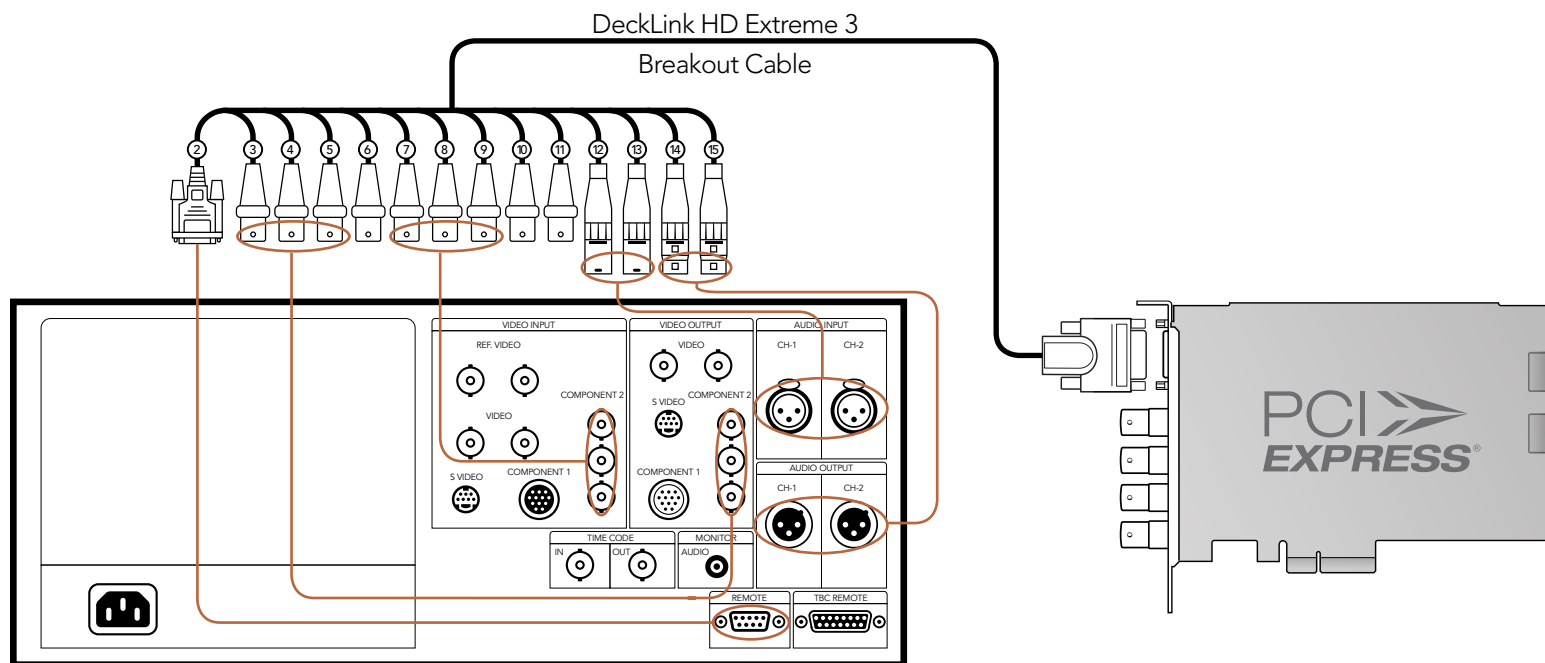

Cards which can be used in this workflow...

DeckLink Studio
DeckLink HD Extreme 3

Previous DeckLink cards

DeckLink SP
DeckLink SP PCIe
DeckLink Extreme
DeckLink Extreme PCIe
DeckLink HD Extreme
DeckLink HD Extreme 2

30 Connection Diagrams

Connecting to an SDI digital deck

This example shows DeckLink HD Extreme 3 connected to a digital deck in 4:2:2 SD mode for capture and playback to the SDI deck. The HDMI, spare SDI and analog outputs can be used for local monitoring.

Cards which can be used in this workflow...

- DeckLink SDI
- DeckLink Studio
- DeckLink HD Extreme 3

Previous DeckLink cards

- DeckLink
- DeckLink Pro
- DeckLink Extreme
- DeckLink Extreme PCIe
- DeckLink HD Pro PCI-X
- DeckLink HD Pro PCIe
- DeckLink HD Extreme
- DeckLink HD Extreme 2

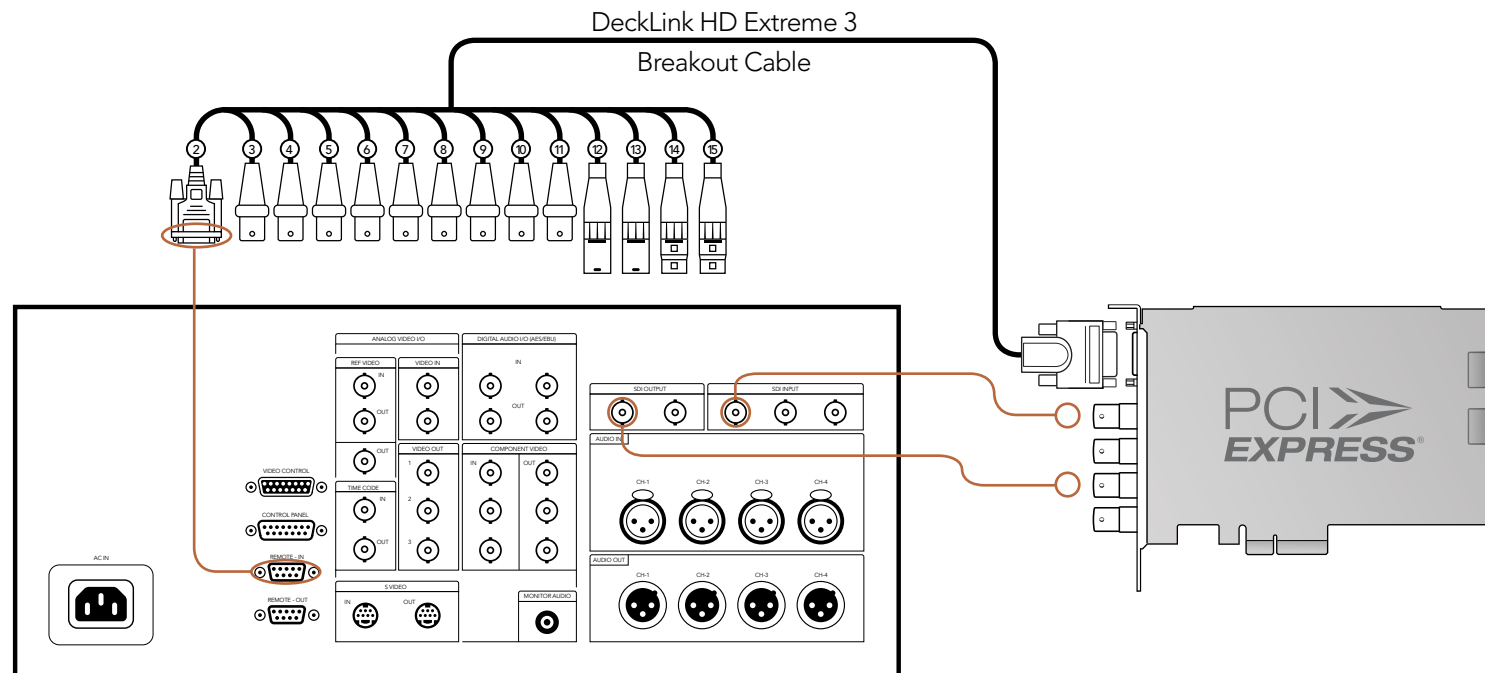

32 Connection Diagrams

Cards which can be used in this workflow...

DeckLink HD Extreme 3

Previous DeckLink cards

DeckLink HD Pro PCI-X

DeckLink HD Pro PCIe

Connecting to a Sony HDCAM SR deck in 4:4:4

This example shows DeckLink HD Extreme 3 connected to a Sony HDCAM SR™ series digital deck in 4:4:4 HD mode. In this case, 4 HD-SDI connections are used for dual-link HD-SDI 4:4:4 video in and out. The HDMI and component analog outputs can be used for local monitoring of 4:4:4 HD video.

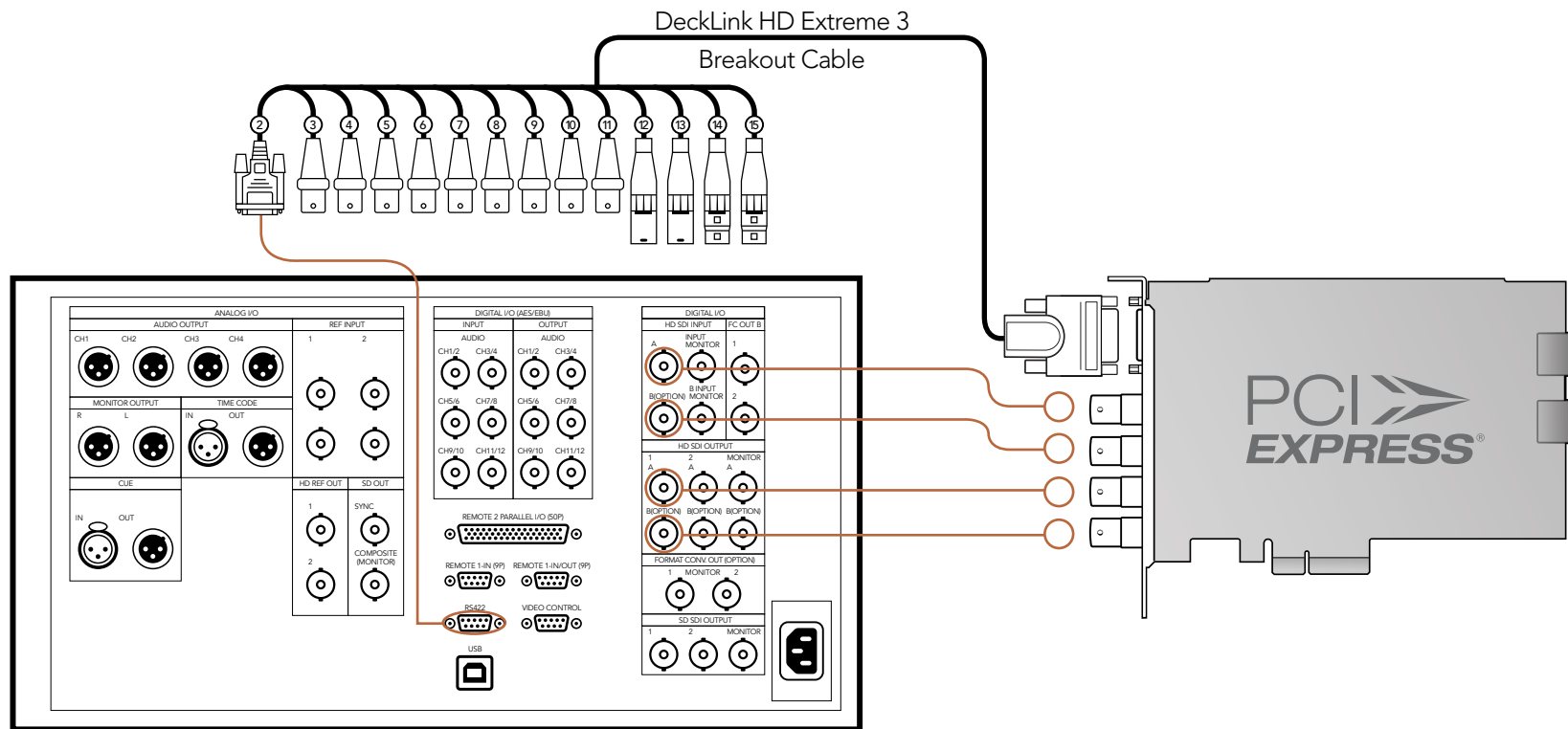

33 Connection Diagrams

Connecting to an NTSC/PAL monitor

This example shows DeckLink HD Extreme 3 connected to a standard definition Sony PVM monitor via composite analog video. Connect a BNC cable from DeckLink's Y output cable to the composite analog video input of the Sony PVM monitor. You can use this for SD capture and playback monitoring with analog, SDI and HDMI video sources.

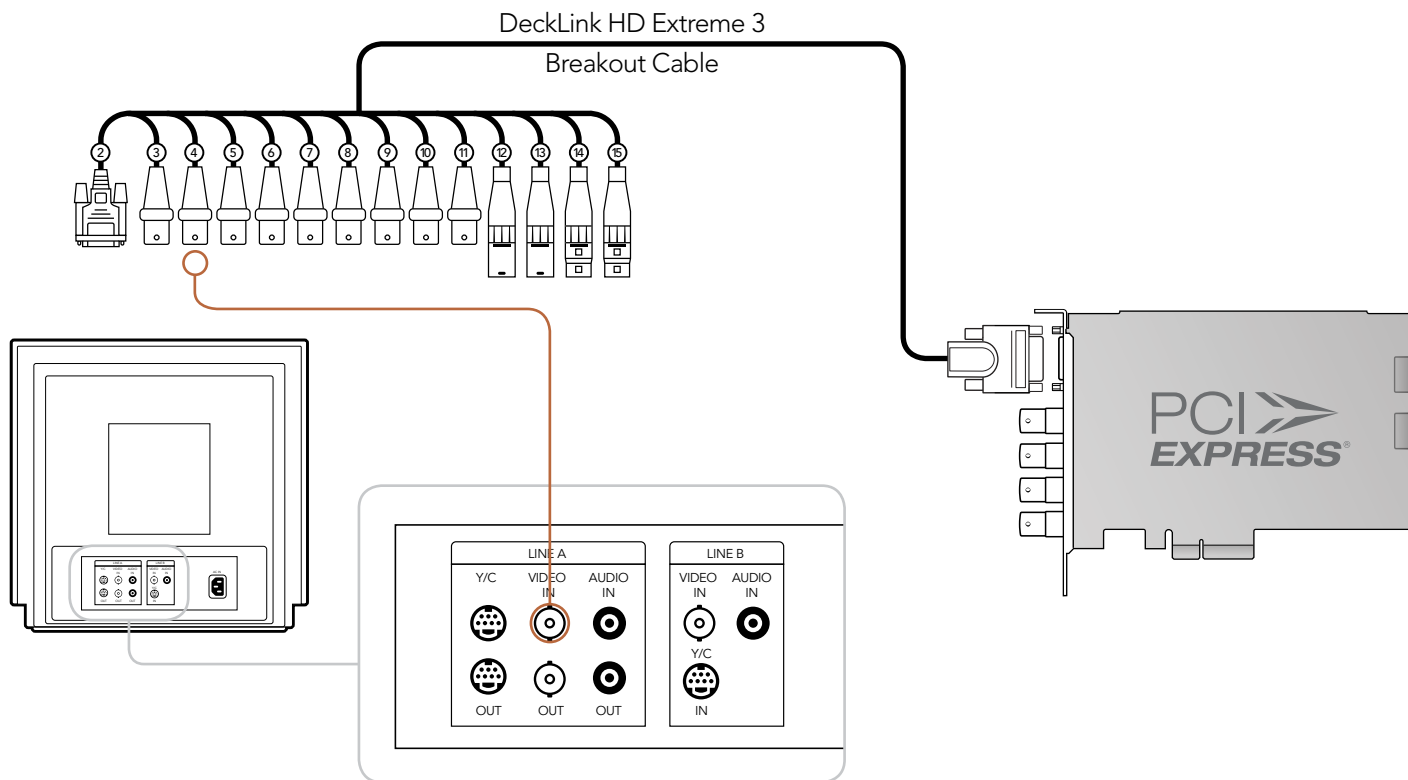

Cards which can be used in this workflow...

DeckLink Studio
DeckLink HD Extreme 3

Previous DeckLink cards

DeckLink SP
DeckLink SP PCIe
DeckLink Pro
DeckLink Extreme
DeckLink Extreme PCIe
DeckLink HD Pro PCI-X
DeckLink HD Pro PCIe
DeckLink HD Extreme
DeckLink HD Extreme 2

34 Connection Diagrams

DeckLink HD Extreme 3 - Connecting to S-Video

This example shows the DeckLink HD Extreme 3 Breakout Cable connecting to S-video adapter cables.

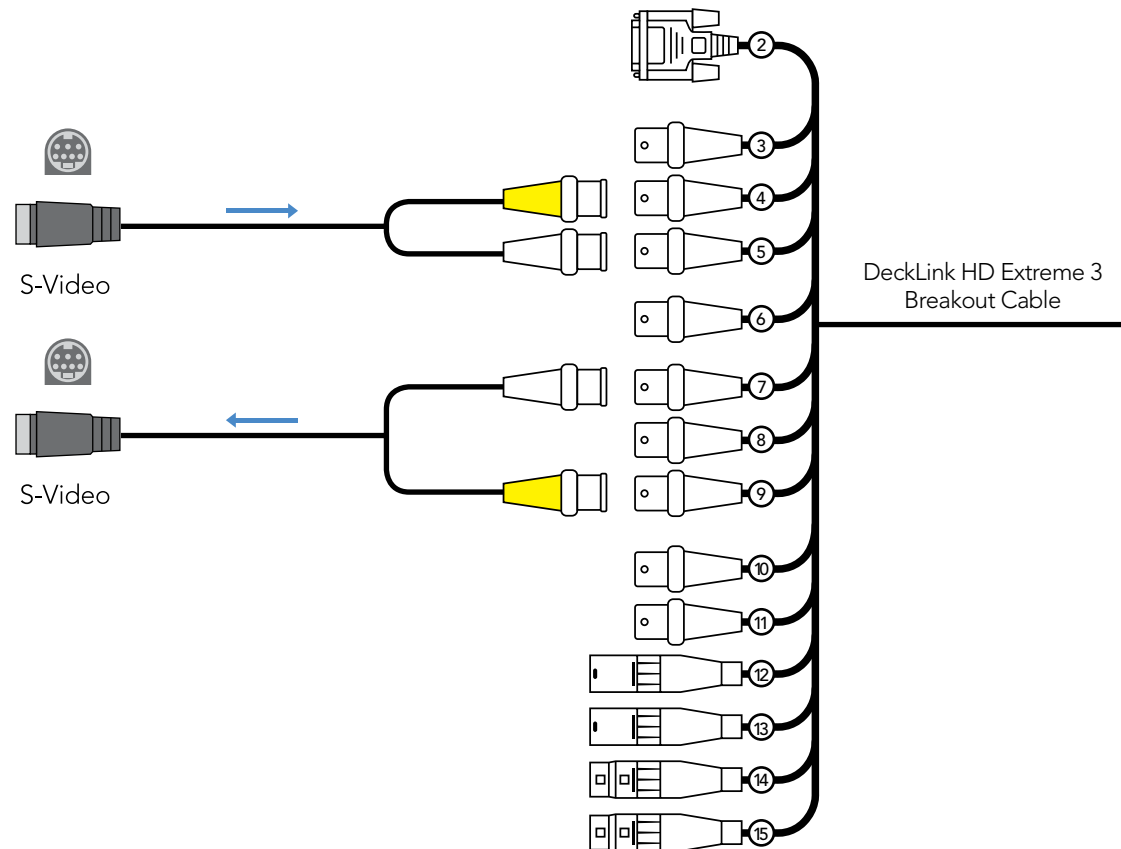

35 Connection Diagrams

Connecting to a YUV component monitor

This example shows DeckLink HD Extreme 3 connected to a multiformat Sony BVM monitor via component analog video. Connect three BNC cables from DeckLink's Y, B-Y and R-Y output cables to the corresponding component analog inputs of the Sony BVM monitor. You can use this for SD or HD capture and playback monitoring with analog, SDI and HDMI video sources.

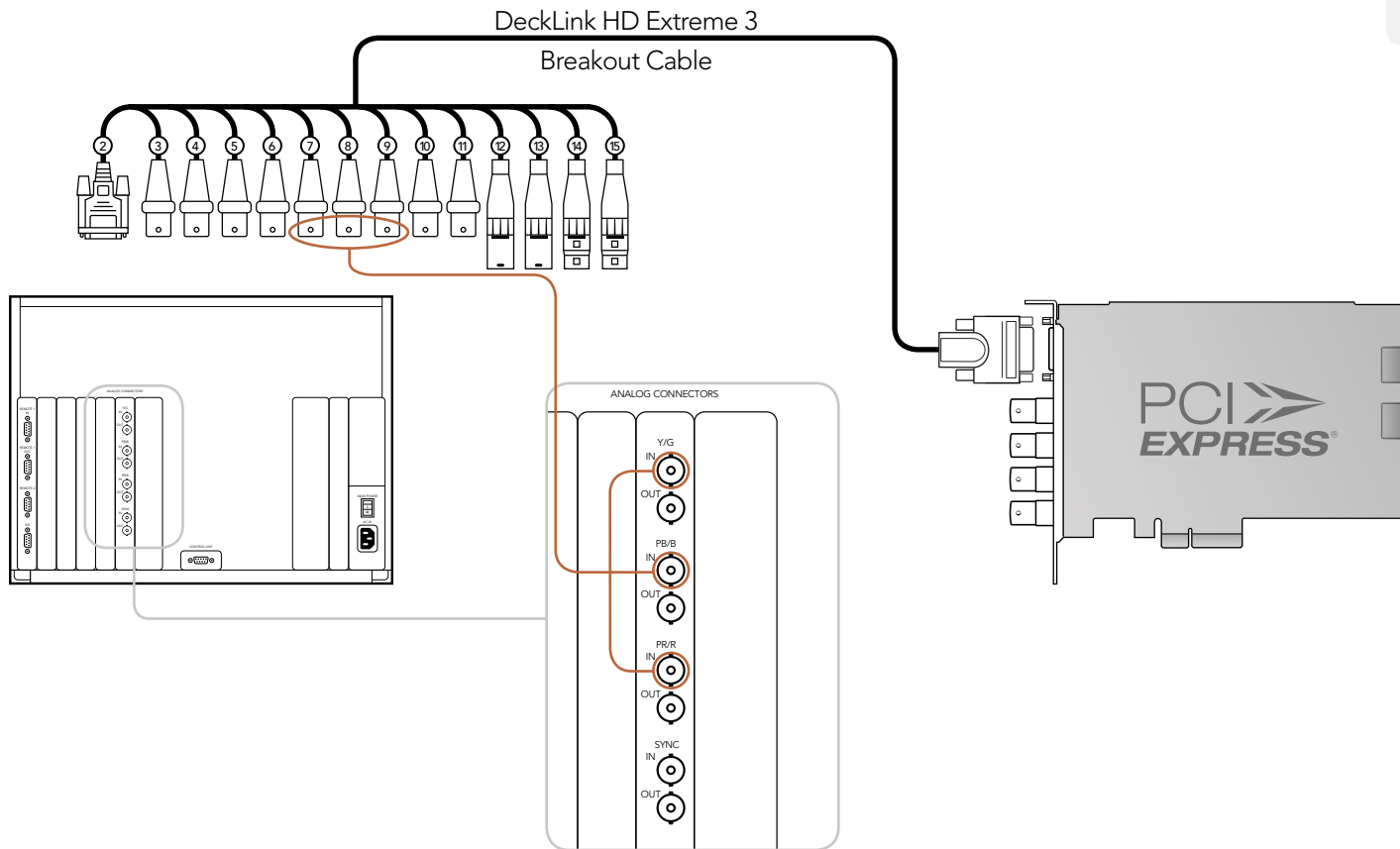

Cards which can be used in this workflow...

DeckLink Studio
DeckLink HD Extreme 3

Previous DeckLink cards

DeckLink SP
DeckLink SP PCIe
DeckLink Pro
DeckLink Extreme
DeckLink Extreme PCIe
DeckLink HD Pro PCI-X
DeckLink HD Pro PCIe
DeckLink HD Extreme
DeckLink HD Extreme 2

36 Connection Diagrams

Cards which can be used in this workflow...

DeckLink HD Extreme 3

Previous DeckLink cards

DeckLink HD Extreme 2

Connecting to an HDTV

This example shows DeckLink HD Extreme 3 connected to a consumer HDTV via HDMI. Connect a HDMI cable from DeckLink's HDMI output to the HDMI input of the HDTV. You can use this for SD or HD capture and playback monitoring of analog, SDI and HDMI video sources.

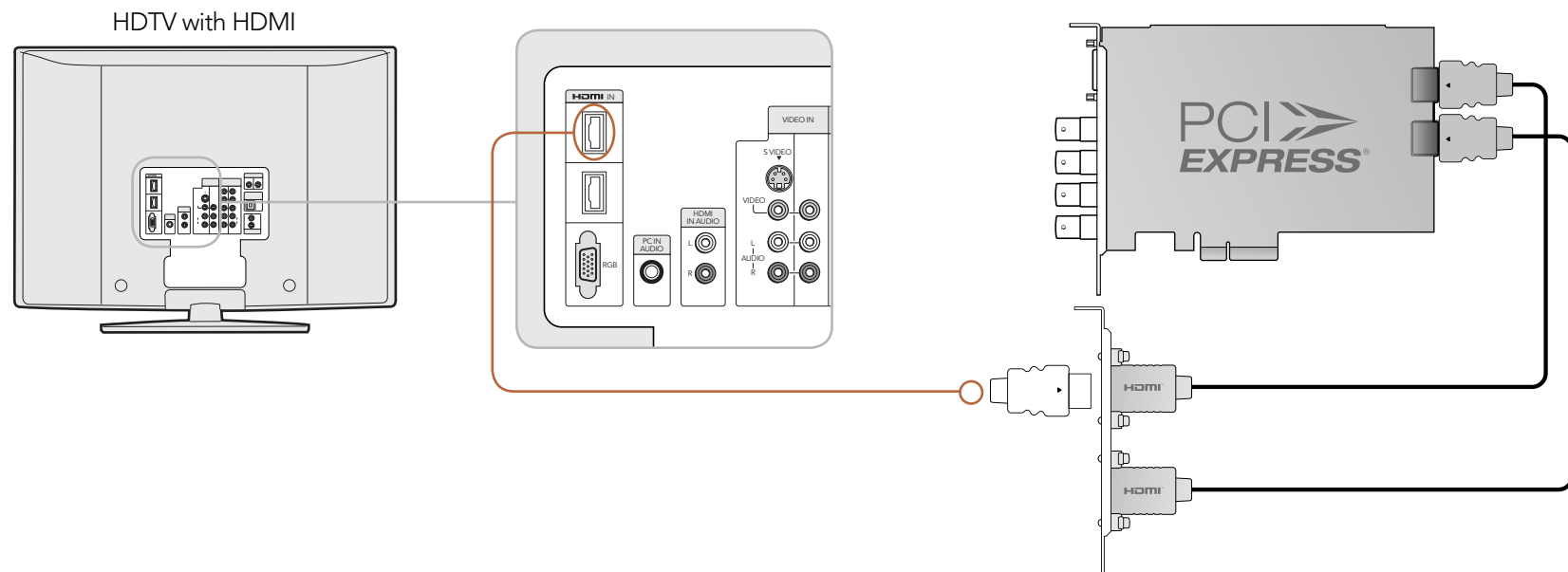

37 Connection Diagrams

HDMI Workflow

DeckLink HD Extreme 3 can use HDMI for connecting video cameras, televisions and projectors to your computer for use with popular editing and design applications. DeckLink HD Extreme 3 captures video in real-time directly from the HDMI output on HDV cameras, and will play back directly to large screen HDTVs or HD projectors for client-monitoring and editing.

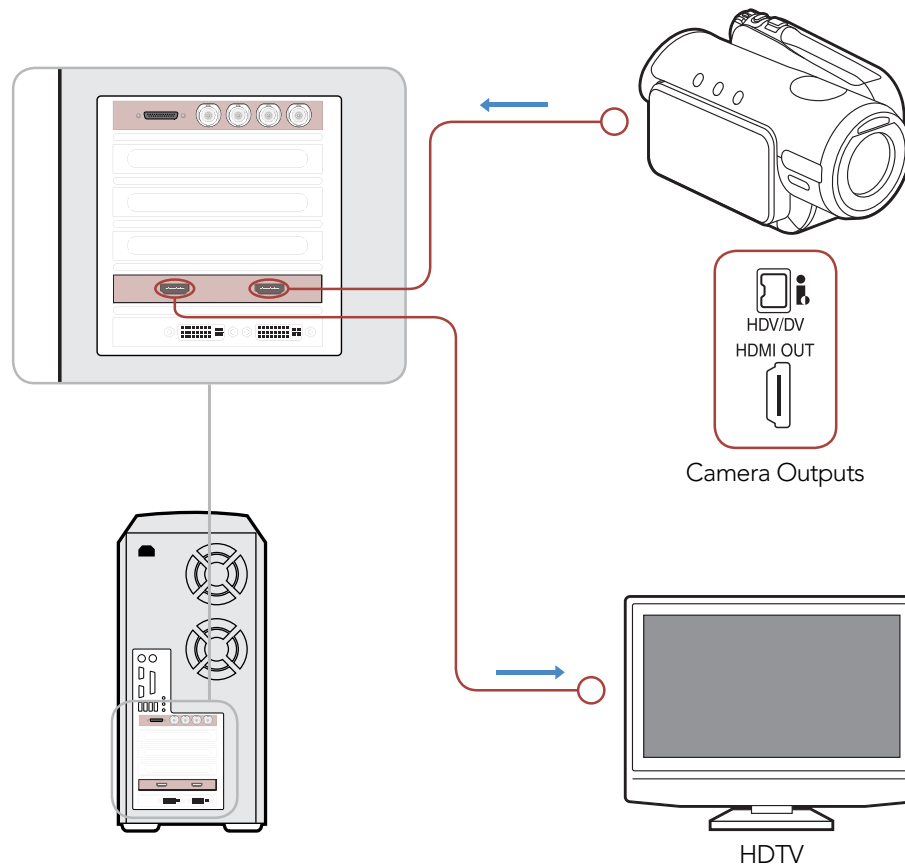

Cards which can be used in this workflow...

DeckLink HD Extreme 3

Previous DeckLink cards

DeckLink HD Extreme 2

38 Connection Diagrams

Cards which can be used in this workflow...

- DeckLink HD Extreme 3
- Previous DeckLink cards
- DeckLink HD Extreme 2

DeckLink HD Extreme 3 - Monitoring via HDMI

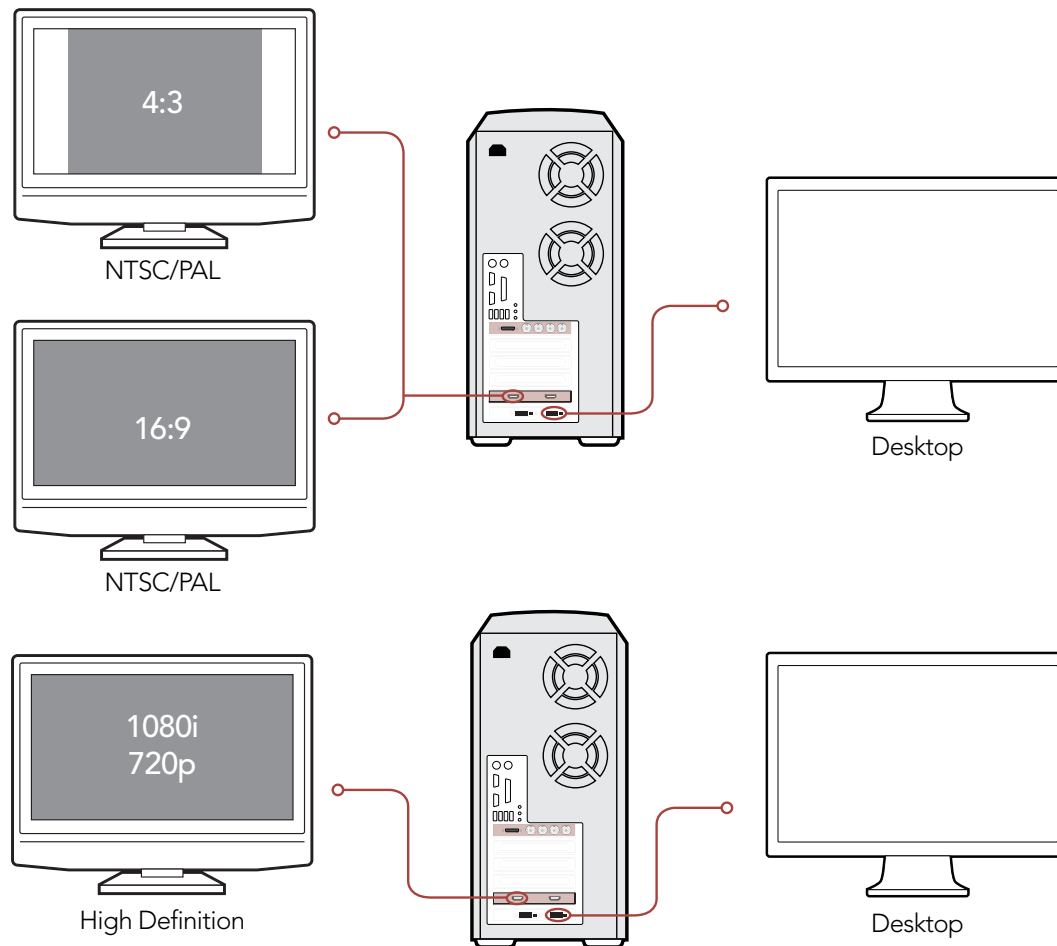

39 Connection Diagrams

DeckLink HD Extreme 3 - 2K Monitoring with HDLink Pro

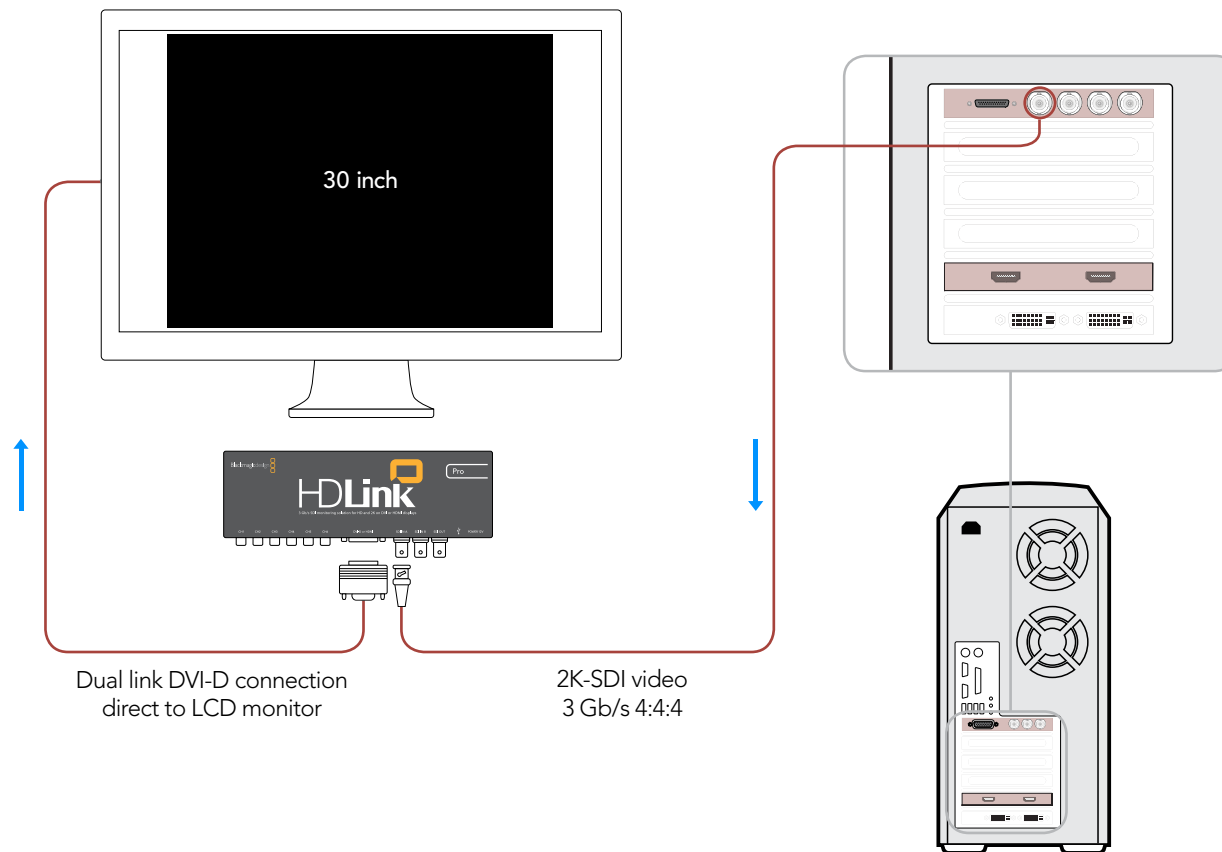

Cards which can be used in this workflow...

DeckLink HD Extreme 3

Previous DeckLink cards

DeckLink HD Extreme 2

DeckLink Series Operation Manual

Device Diagrams

41 Device Diagrams

DeckLink HD Extreme 3

All SDI inputs and outputs support 3 Gb/s SDI and 2K.

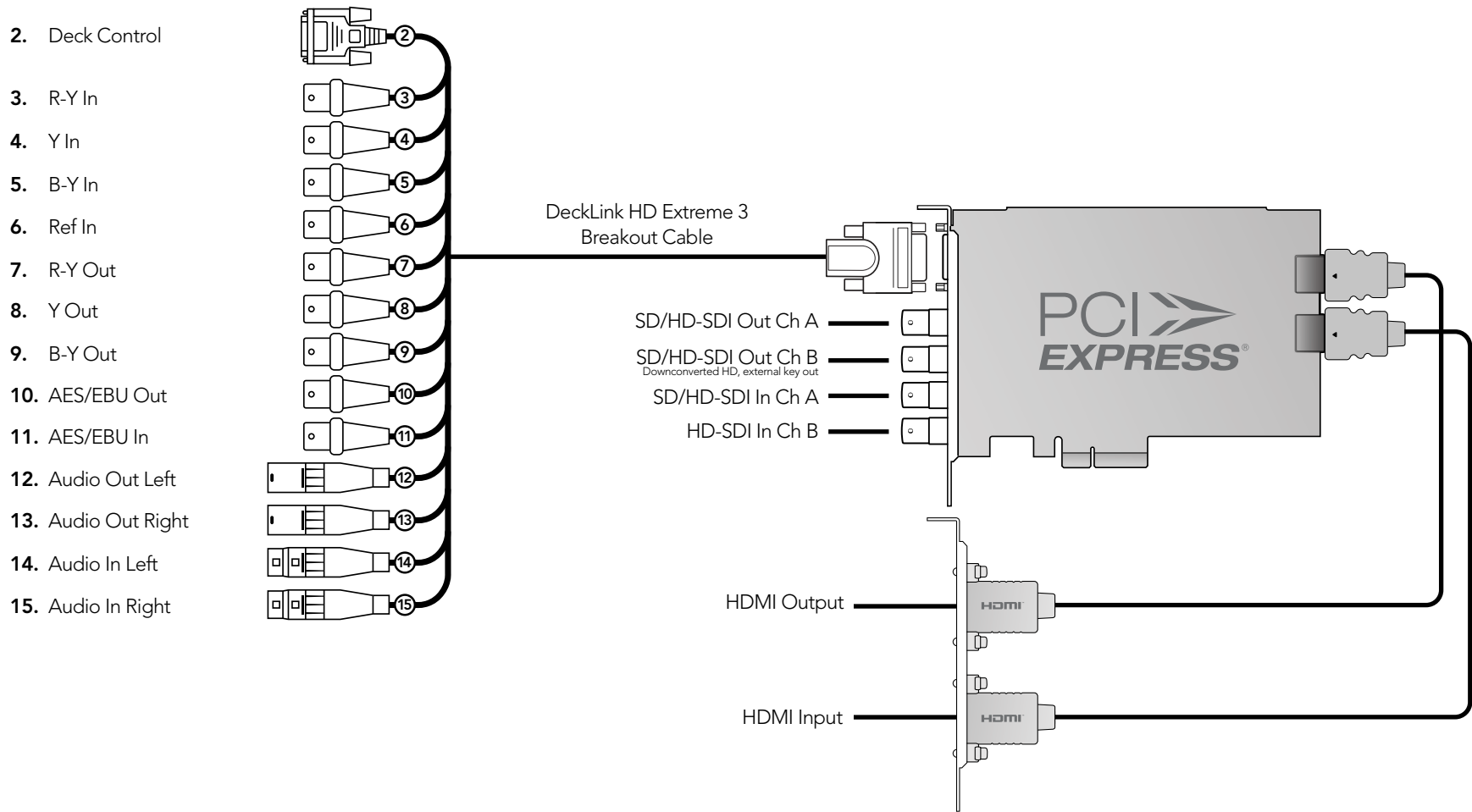

42 Device Diagrams

DeckLink SDI

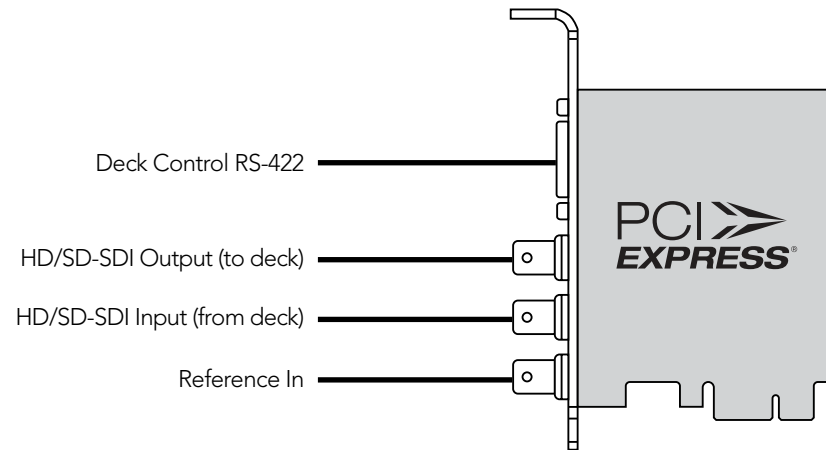

43 Device Diagrams

DeckLink Studio

2. RS-422 Deck Control

3. Component Out

4. Component Out

5. Component Out

6. Genlock Tri-Sync In

7. Component In

8. Component In

9. Component In

10. AES / EBU Out

11. AES / EBU In

12. Analog Audio Out 1

13. Analog Audio Out 2

14. Analog Audio Out 3 or AES / EBU Out

15. Analog Audio Out 4 or AES / EBU Out

16. Analog Audio In 1

17. Analog Audio In 2

18. Analog Audio In 3

19. Analog Audio In 4

20. Composite In

21. Composite Out

22. S-Video In

23. S-Video Out

24. Standard Definition SDI Out

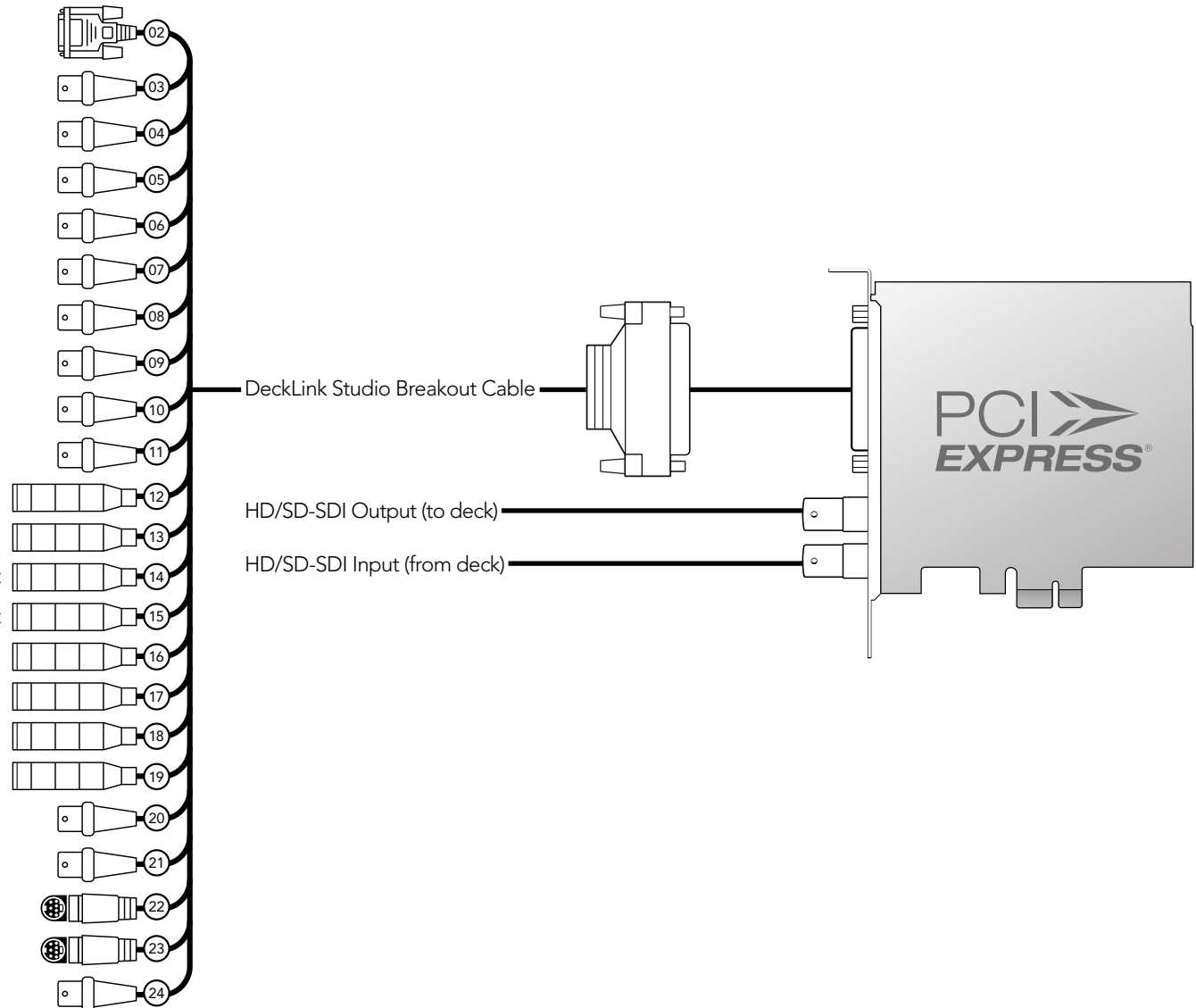

DeckLink Series Operation Manual

Developer Information

Blackmagic 2K Format

The latest Blackmagic Design products use the new 3 Gb/s SDI video, which allows twice the data rate of traditional HD-SDI video. We thought it would be a really nice idea to add 2K film support, via this new 3 Gb/s SDI technology, so we could simplify feature film workflows. With the popularity of Blackmagic Design editing systems worldwide, now thousands of people can benefit from a feature film workflow revolution.

This information includes everything product developers need to know for building native 2K SDI equipment. Of course, all Blackmagic products can be updated, so if the television industry adopts an alternative SDI-based film standard, we can add support for that too!

Frame Structure

- Transmitted at 23.98 or 24 frames per second as a Progressive Segmented Frame.
- Active video is 2048 pixels wide by 1556 lines deep.
- Total lines per frame : 1650
- Words per active line. One word consists of a sample on both data streams: 3072 (2048*3/2). See following page.
- Total active lines : 1556
- Words per total line : 3750.
- Fields per frame : 2, 825 lines each
- Active lines located on lines 16-793 (field 1) and 841-1618 (field 2).

Transport Structure

- Based on SMPTE S425M mapping structure 2.
- Timing reference signals, line number and line CRC insertion is the same as above.
- Optional ancillary data is inserted into both virtual interfaces.
- At present, only audio data is included: as per standard HD audio insertion (SMPTE S299M) the audio data packets are carried on data stream two and audio control packets are carried on data stream one.
- During active video, 10-bit Red, Green and Blue data is sent in the following sequence:
Data stream 1: Green₁, Red₁, Green₂, Green₃, Red₃, Green₄, ..., Green_{n-1}, Red_{n-1}, Green_n.
Data stream 2: Blue₁, Red₂, Blue₂, Blue₃, Red₄, Blue₄, ..., Blue_{n-1}, Red_n, Blue_n.

Diagrams on the following page show the vertical timing details with line numbers and Field, Vertical and Horizontal bits for the Timing Reference Signal codes.

Final diagram shows the data stream formats around the optional ancillary data section of the horizontal line. Note that each active pixel takes up three samples.

46 Developer Information

Blackmagic 2K Format

		Active Lines																												
FVH	101	100	111	110	111	110	011	010	011	010	011	010	011	010	011	010	001	000	001	000	001	000	001	000	011	010	011	010	011	010
TRS	E	S	E	S	E	S	E	S	E	S	E	S	E	S	E	S	E	S	E	S	E	S	E	S	E	S	E	S	E	S
LINE#	1618	1619...	1650		1	2	3...	14	15	16	17...	792	793	794...	824	825														

← FIRST FIELD →

		Active Lines																												
FVH	001	000	011	010	011	010	111	110	111	110	111	110	111	110	111	110	101	100	101	100	101	100	101	100	111	110	111	110	111	110
TRS	E	S	E	S	E	S	E	S	E	S	E	S	E	S	E	S	E	S	E	S	E	S	E	S	E	S	E	S	E	S
LINE#	823	824	825	826	827	828...	839	840	841	842...	1617	1618	1619...	1649	1650															

← SECOND FIELD →

DATA STREAM 1	DATA STREAM 2	WORD#
G2045	B2045	3745
R2045	R2046	3746
G2046	B2046	3747
G2047	B2047	3748
R2047	R2048	3749
G2048	B2048	3750
EAV(3FFh)	EAV(3FFh)	1
EAV(000h)	EAV(000h)	2
EAV(000h)	EAV(000h)	3
EAV(XYZh)	EAV(XYZh)	4
LN0	LN0	5
LN1	LN1	6
CR0	CR0	7
CR1	CR1	8
REPLACED BY OPTIONAL ANCILLARY DATA	REPLACED BY OPTIONAL ANCILLARY DATA	9-674
SAV(3FFh)	SAV(3FFh)	675
SAV(000h)	SAV(000h)	676
SAV(000h)	SAV(000h)	677
SAV(XYZh)	SAV(XYZh)	678
G1	B1	679
R1	R2	680
G2	B2	681
G3	B3	682
R3	R4	683
G4	B4	684
G5	B5	685
R5	R6	686

DeckLink Series Operation Manual

Previous DeckLink Cards– Connection Diagrams

Connection Diagrams

Connecting to a Betacam SP analog deck

This example shows DeckLink HD Extreme 2 connected to an analog deck for capture and playback to the deck. The HDMI and SDI outputs can be used for local monitoring.

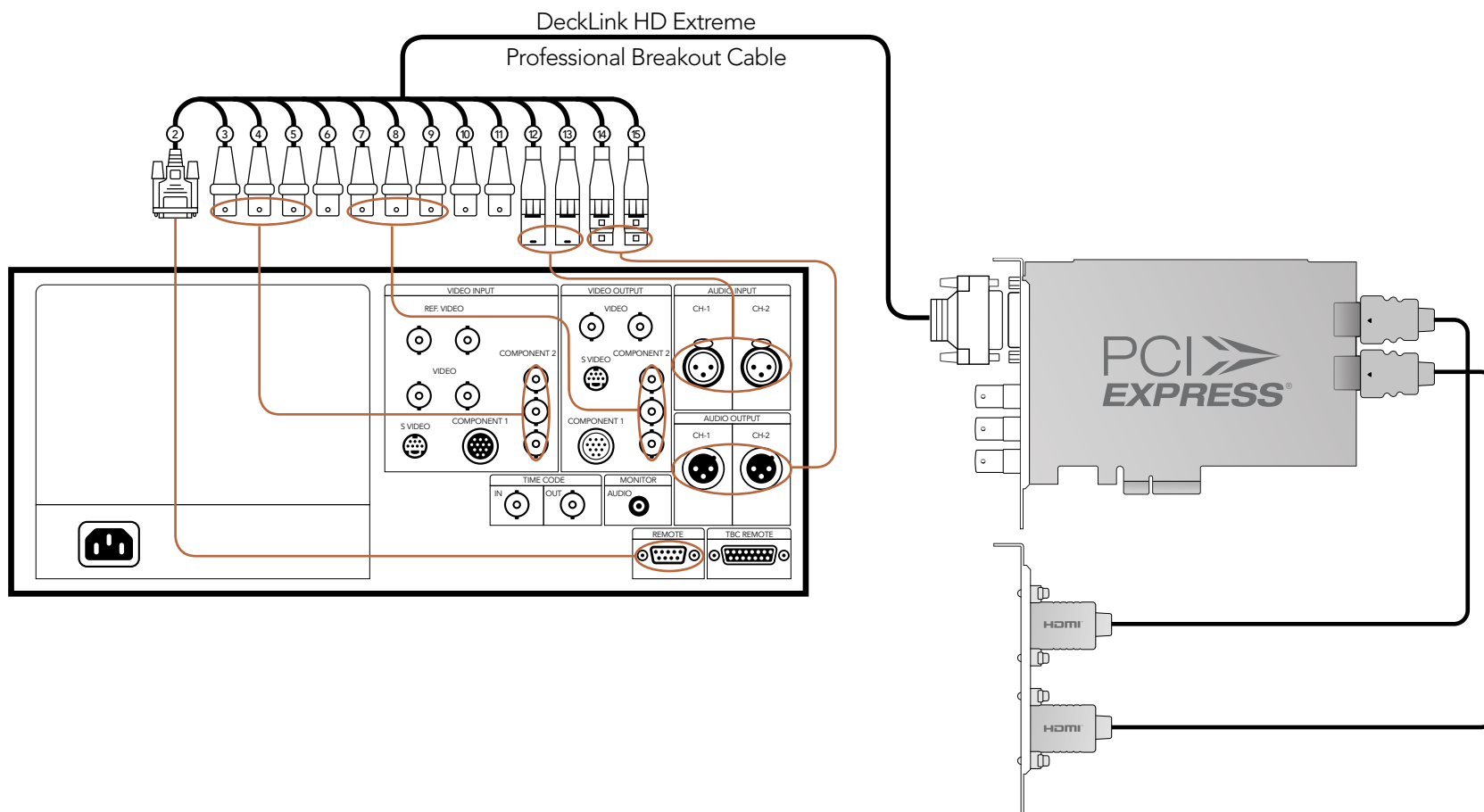

Cards which can be used in this workflow...

DeckLink Studio
DeckLink HD Extreme 3

Previous DeckLink cards

DeckLink SP
DeckLink SP PCIe
DeckLink Extreme
DeckLink Extreme PCIe
DeckLink HD Extreme
DeckLink HD Extreme 2

Connection Diagrams

Connecting to an SDI digital deck

This example shows DeckLink HD Extreme 2 connected to a digital deck in 4:2:2 SD mode for capture and playback to the SDI deck. The HDMI, spare SDI and analog outputs can be used for local monitoring.

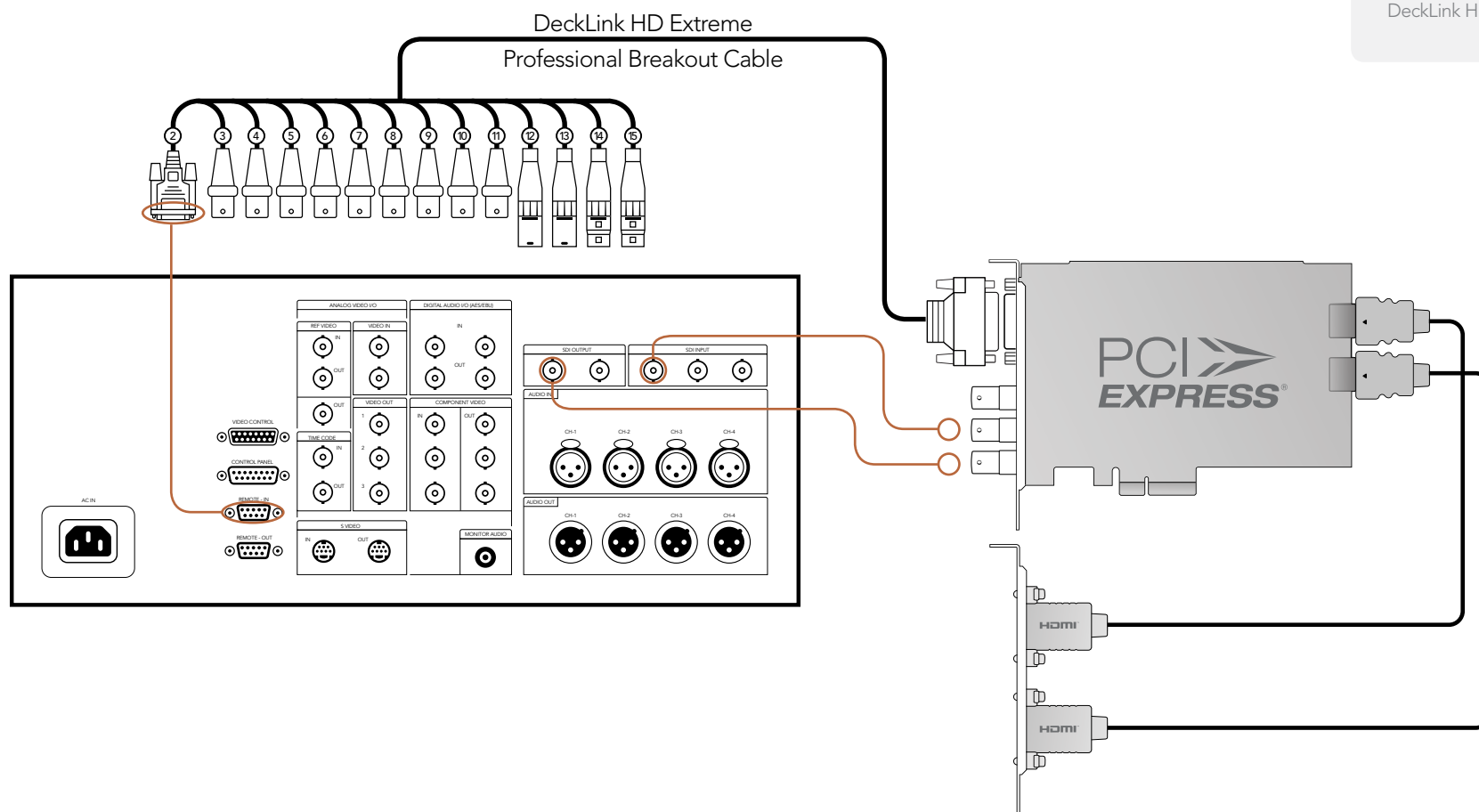

Cards which can be used in this workflow...

DeckLink SDI
DeckLink Studio
DeckLink HD Extreme 3

Previous DeckLink cards

DeckLink
DeckLink Pro
DeckLink Extreme
DeckLink Extreme PCIe
DeckLink HD Pro PCI-X
DeckLink HD Pro PCIe
DeckLink HD Extreme
DeckLink HD Extreme 2

Connection Diagrams

Connecting to a Sony HDCAM SR deck in 4:2:2

This example shows DeckLink HD Extreme 2 connected to a Sony HDCAM SR™ series digital deck in 4:2:2 HD mode for capture and playback to the HD-SDI deck. The HDMI, spare SDI and component analog outputs can be used for local monitoring of 4:2:2 HD video.

Cards which can be used in this workflow...

DeckLink SDI
DeckLink Studio
DeckLink HD Extreme 3

Previous DeckLink cards

DeckLink HD Pro PCI-X
DeckLink HD Pro PCIe
DeckLink HD Extreme
DeckLink HD Extreme 2

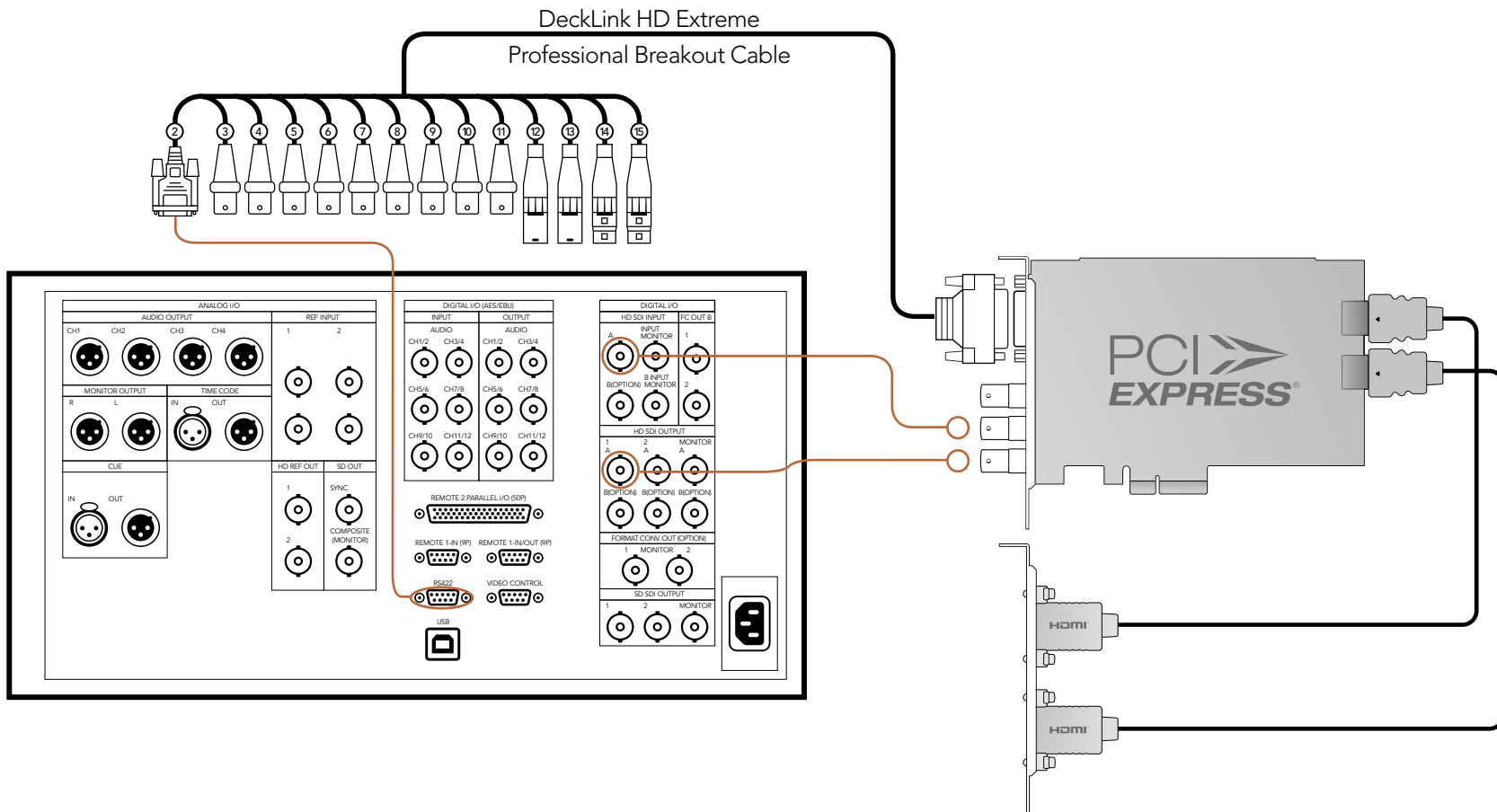

Connection Diagrams

Connecting to a Sony HDCAM SR deck in 4:2:2

This example shows DeckLink HD Pro PCIe connected to a Sony HDCAM SR™ series digital deck in 4:2:2 HD mode. In this case, 2 HD-SDI connections are used for HD-SDI 4:2:2 video in and out. The component analog output can be used for local monitoring of 4:2:2 HD video.

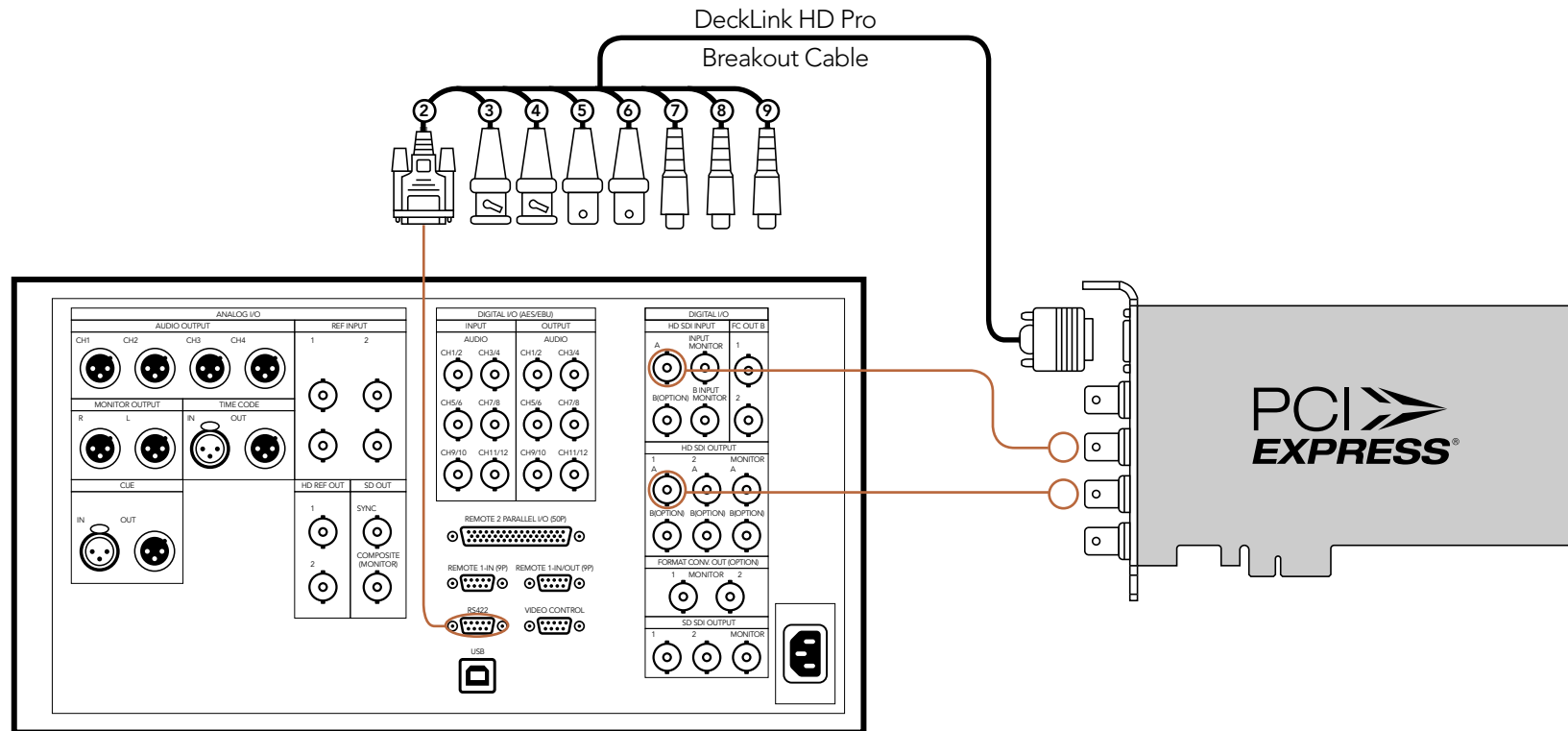

Cards which can be used in this workflow...

DeckLink SDI
DeckLink Studio
DeckLink HD Extreme 3

Previous DeckLink cards

DeckLink HD Pro PCI-X
DeckLink HD Pro PCIe
DeckLink HD Extreme
DeckLink HD Extreme 2

Connection Diagrams

Connecting to a Sony HDCAM SR deck in 4:4:4

This example shows DeckLink HD Pro PCIe connected to a Sony HDCAM SR™ series digital deck in 4:4:4 HD mode. In this case, 4 HD-SDI connections are used for dual-link HD-SDI 4:4:4 video in and out. The component analog output can be used for local monitoring of 4:4:4 HD video.

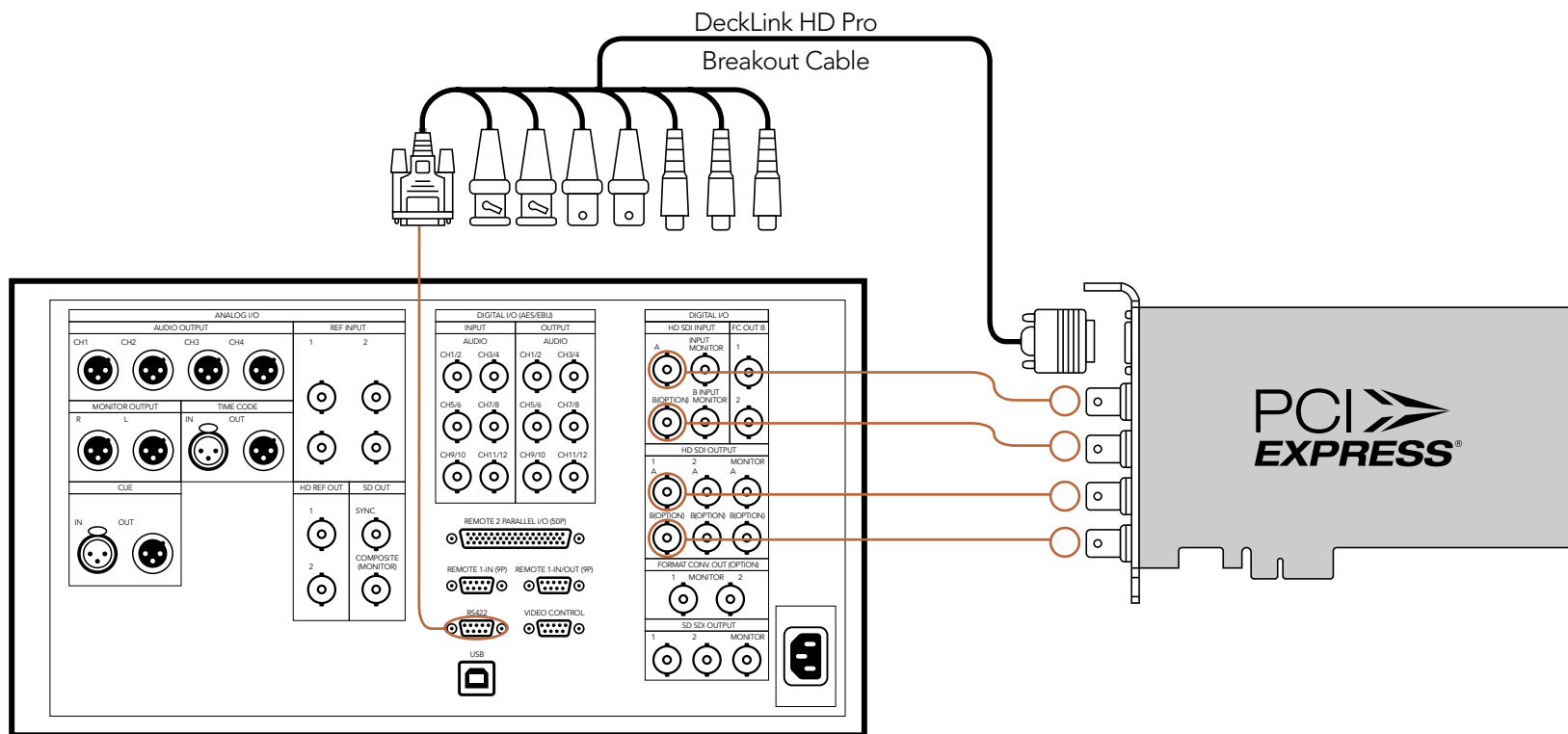

Cards which can be used in this workflow...

DeckLink HD Extreme 3

Previous DeckLink cards

DeckLink HD Pro PCI-X

DeckLink HD Pro PCIe

Connection Diagrams

Connecting to an NTSC/PAL monitor

This example shows DeckLink HD Extreme 2 connected to a standard definition Sony PVM monitor via composite analog video. Connect a BNC cable from DeckLink's Y output cable to the composite analog video input of the Sony PVM monitor. You can use this for SD capture and playback monitoring with analog, SDI and HDMI video sources.

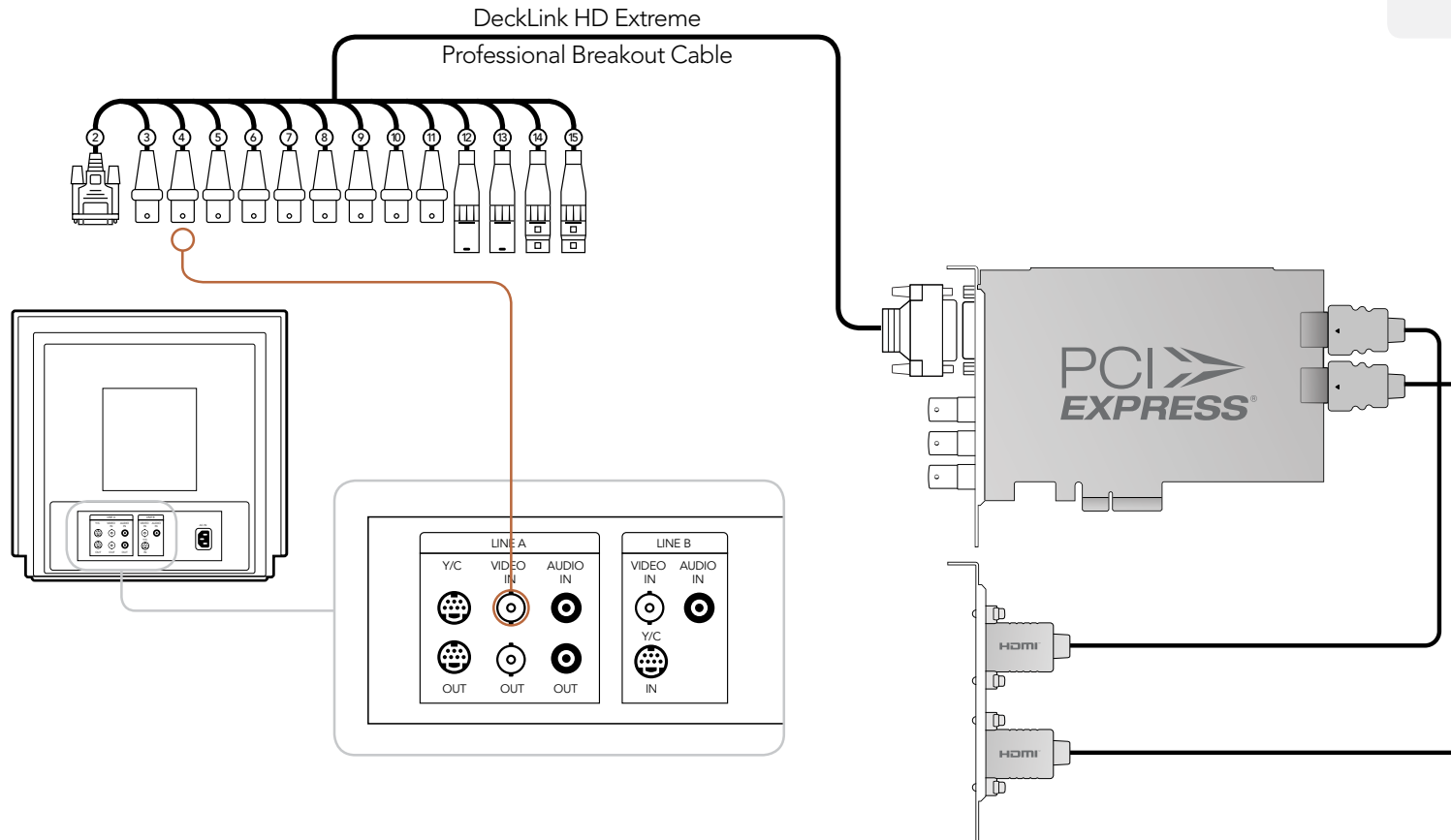

Cards which can be used in this workflow...

DeckLink Studio
DeckLink HD Extreme 3

Previous DeckLink cards

DeckLink SP
DeckLink SP PCIe
DeckLink Pro
DeckLink Extreme
DeckLink Extreme PCIe
DeckLink HD Pro PCI-X
DeckLink HD Pro PCIe
DeckLink HD Extreme
DeckLink HD Extreme 2

Connection Diagrams

DeckLink HD Extreme 2 - connecting to S-Video

This example shows DeckLink HD Extreme 2 connected to a standard definition Sony PVM monitor via composite analog video. Connect a BNC cable from DeckLink's Y output cable to the composite analog video input of the Sony PVM monitor. You can use this for SD capture and playback monitoring with analog, SDI and HDMI video sources.

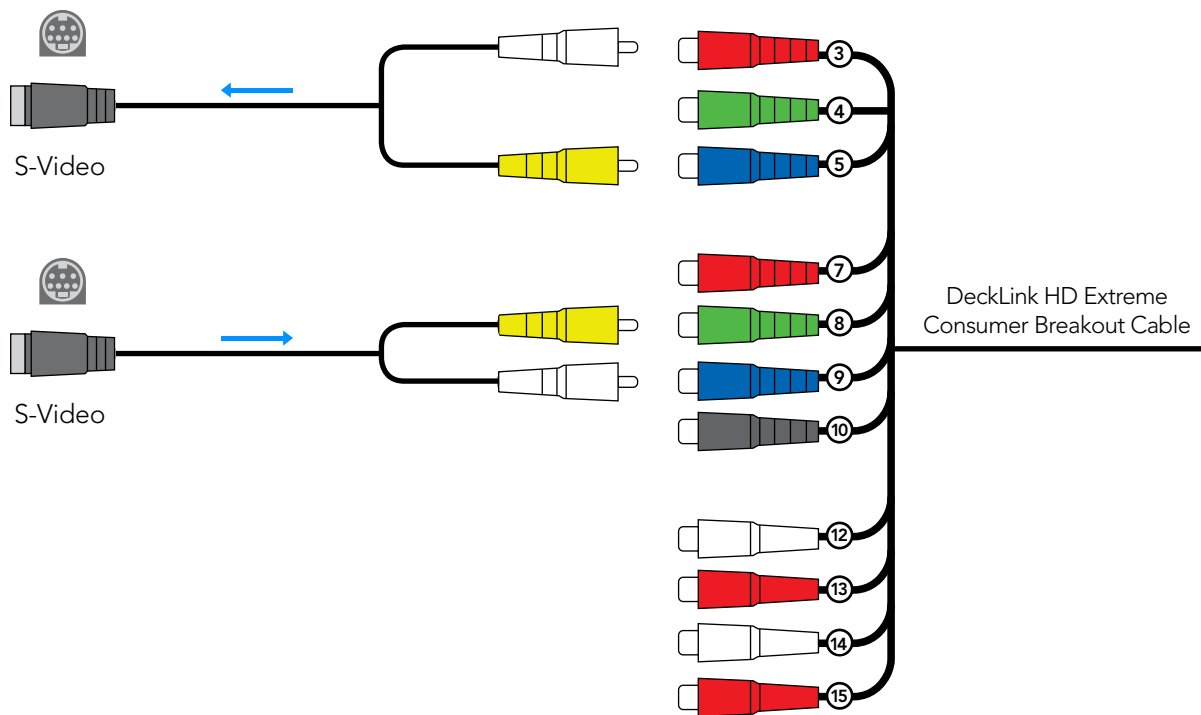

Connection Diagrams

DeckLink HD Extreme - connecting to S-Video

This example shows the DeckLink HD Extreme Consumer Breakout Cable connecting to S-video adapter cables. The Professional Breakout Cable can also be used with S-video adapter cables. The numbering on the cables is the same on both the Consumer and Professional Breakout Cables so it's easy to use either cable.

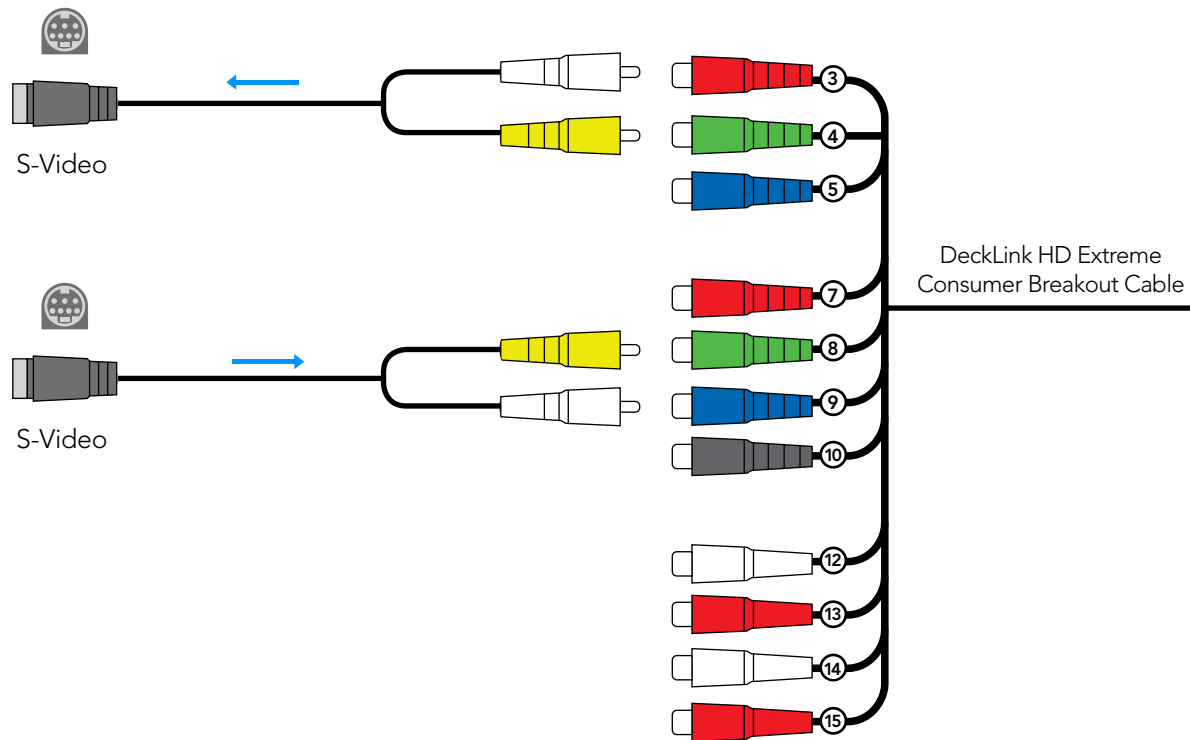

Connection Diagrams

Connecting to a YUV component monitor

This example shows DeckLink HD Extreme 2 connected to a multiformat Sony BVM monitor via component analog video. Connect three BNC cables from DeckLink's Y, B-Y and R-Y output cables to the corresponding component analog inputs of the Sony BVM monitor. You can use this for SD or HD capture and playback monitoring with analog, SDI and HDMI video sources.

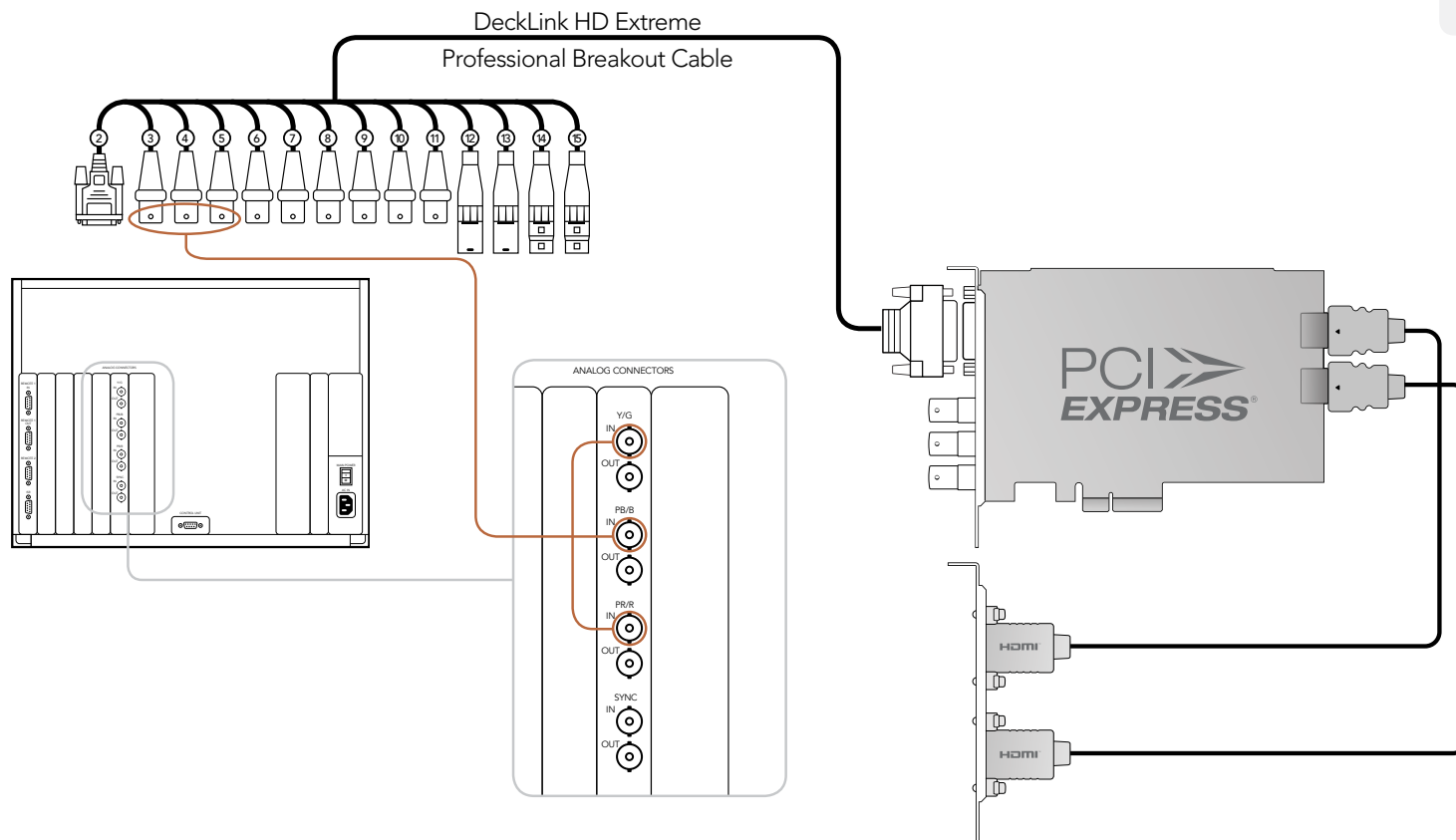

Cards which can be used in this workflow...

DeckLink Studio
DeckLink HD Extreme 3

Previous DeckLink cards

DeckLink SP
DeckLink SP PCIe
DeckLink Pro
DeckLink Extreme
DeckLink Extreme PCIe
DeckLink HD Pro PCI-X
DeckLink HD Pro PCIe
DeckLink HD Extreme
DeckLink HD Extreme 2

Connection Diagrams

Cards which can be used in this workflow...

DeckLink HD Extreme 3

Previous DeckLink cards

DeckLink HD Extreme 2

Connecting to an HDTV

This example shows DeckLink HD Extreme 2 connected to a consumer HDTV via HDMI. Connect a HDMI cable from DeckLink's HDMI output to the HDMI input of the HDTV. You can use this for SD or HD capture and playback monitoring of analog, SDI and HDMI video sources.

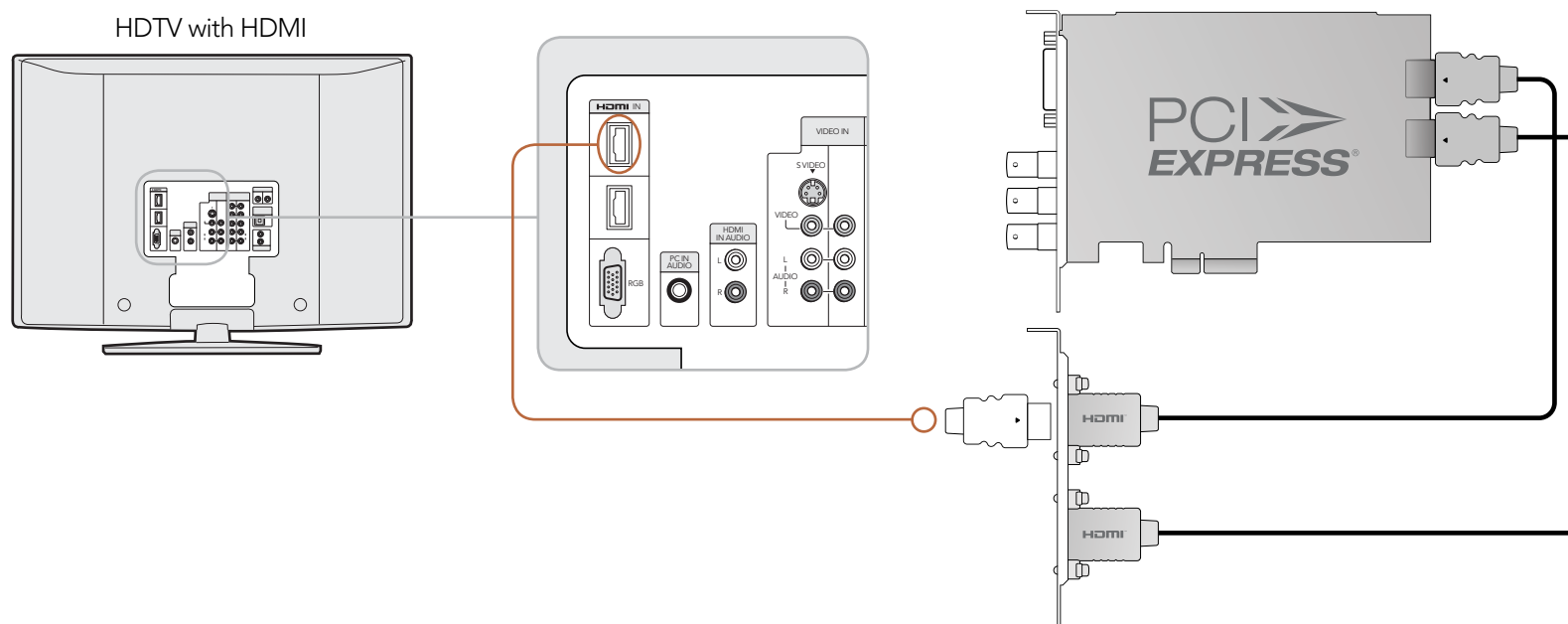

Connection Diagrams

HDMI Workflow

DeckLink HD Extreme 2 can use HDMI for connecting video cameras, televisions and projectors to your computer for use with popular editing and design applications. DeckLink HD Extreme 2 captures video in real-time directly from the HDMI output on HDV cameras, and will play back directly to large screen HDTVs or HD projectors for client-monitoring and editing.

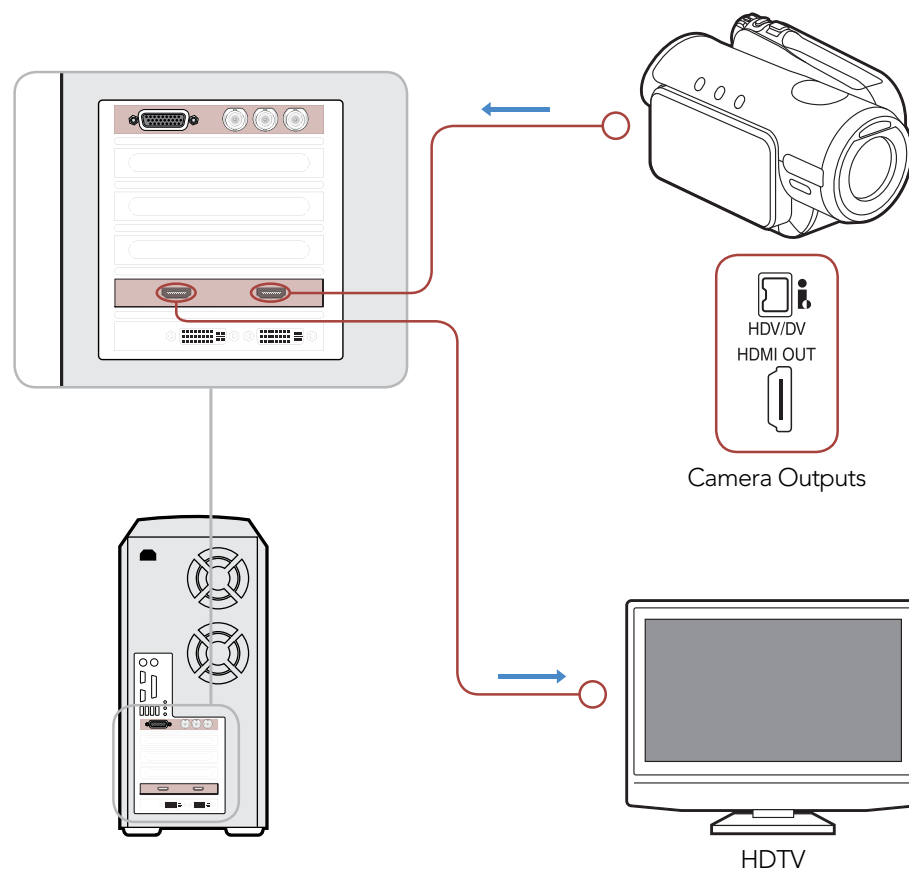

Cards which can be used in this workflow...

DeckLink HD Extreme 3

Previous DeckLink cards

DeckLink HD Extreme 2

59 Connection Diagrams

DeckLink HD Extreme 2 - monitoring via HDMI

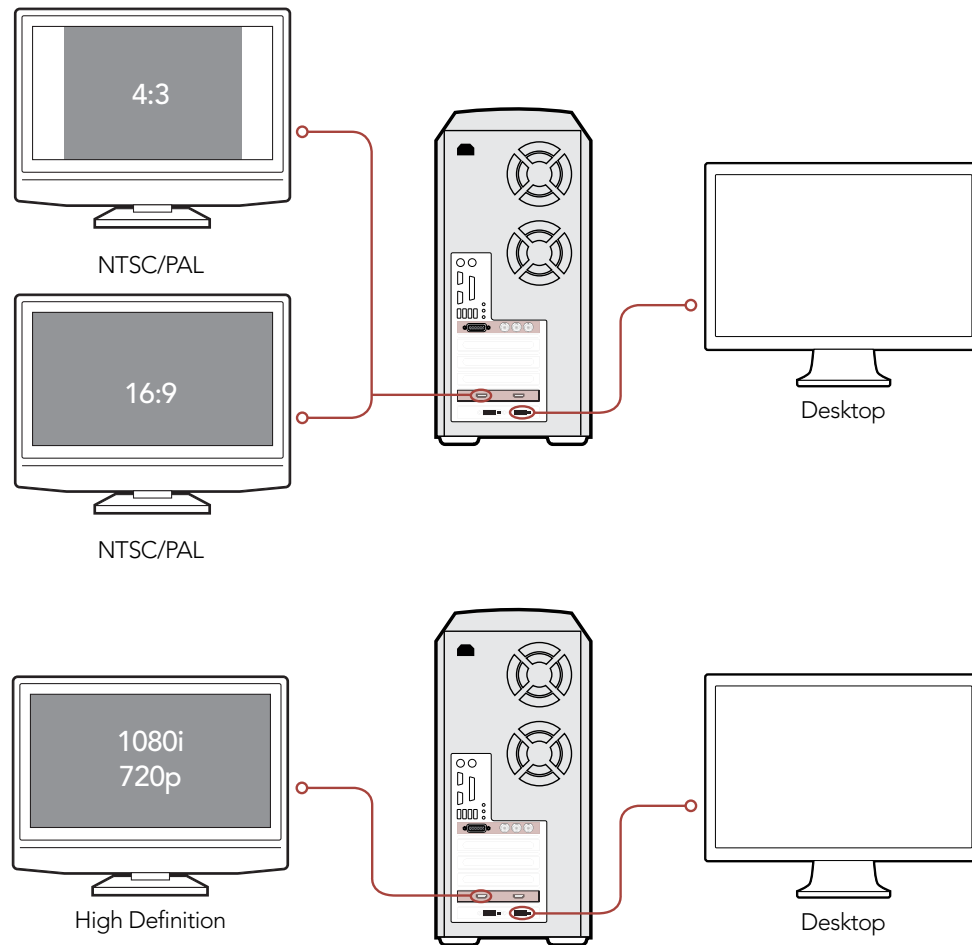

Connection Diagrams

DeckLink HD Extreme 2 - 2K Monitoring with HDLink Pro

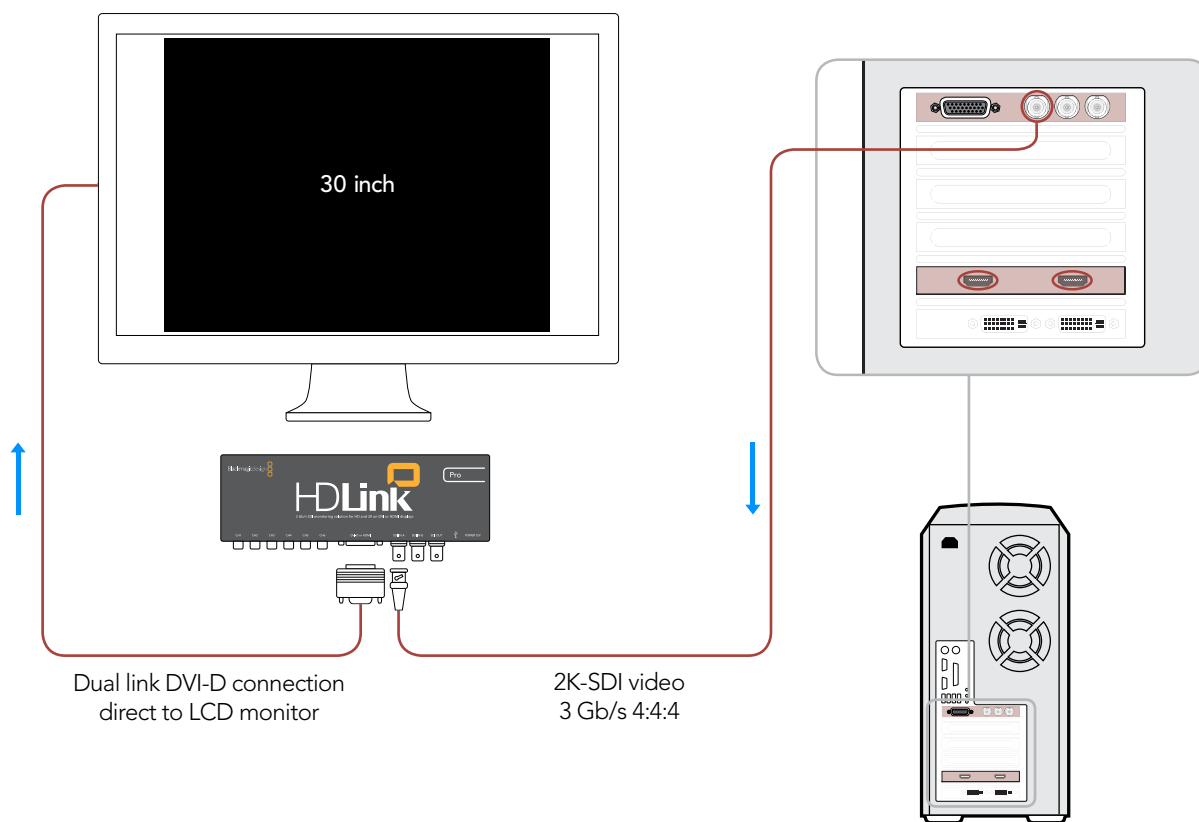

DeckLink Series Operation Manual

Previous DeckLink Cards– Device Diagrams

62 Device Diagrams

DeckLink HD Extreme 2 and Professional Breakout Cable

DeckLink HD Extreme 2 can use HDMI for connecting video cameras, televisions and projectors to your computer for use with popular editing and design applications. DeckLink HD Extreme 2 captures video in real-time directly from the HDMI output on HDV cameras, and will play back directly to large screen HDTVs or HD projectors for client-monitoring and editing.

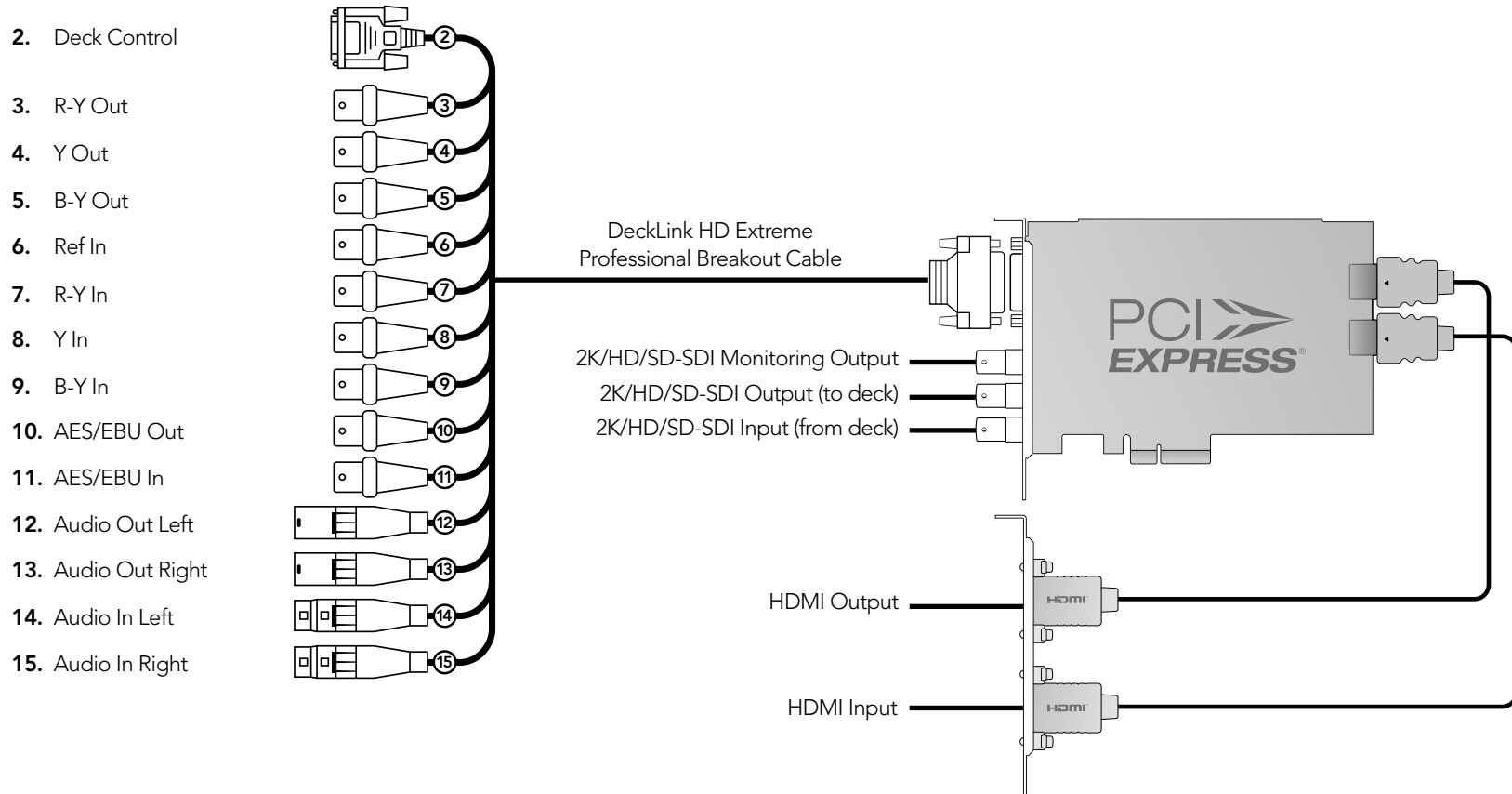

63 Device Diagrams

DeckLink HD Extreme 2 and Consumer Breakout Cable

The cable numbering is the same on both the Professional and Consumer Breakout Cables so it's easy to use either cable. For example, component video output uses cables 3, 4 and 5 on both breakout cables.

- 3. R-Y Out
- 4. Y Out
- 5. B-Y Out

- 7. R-Y In
- 8. Y In
- 9. B-Y In
- 10. AES/EBU Out

- 12. Audio Out Left
- 13. Audio Out Right
- 14. Audio In Left
- 15. Audio In Right

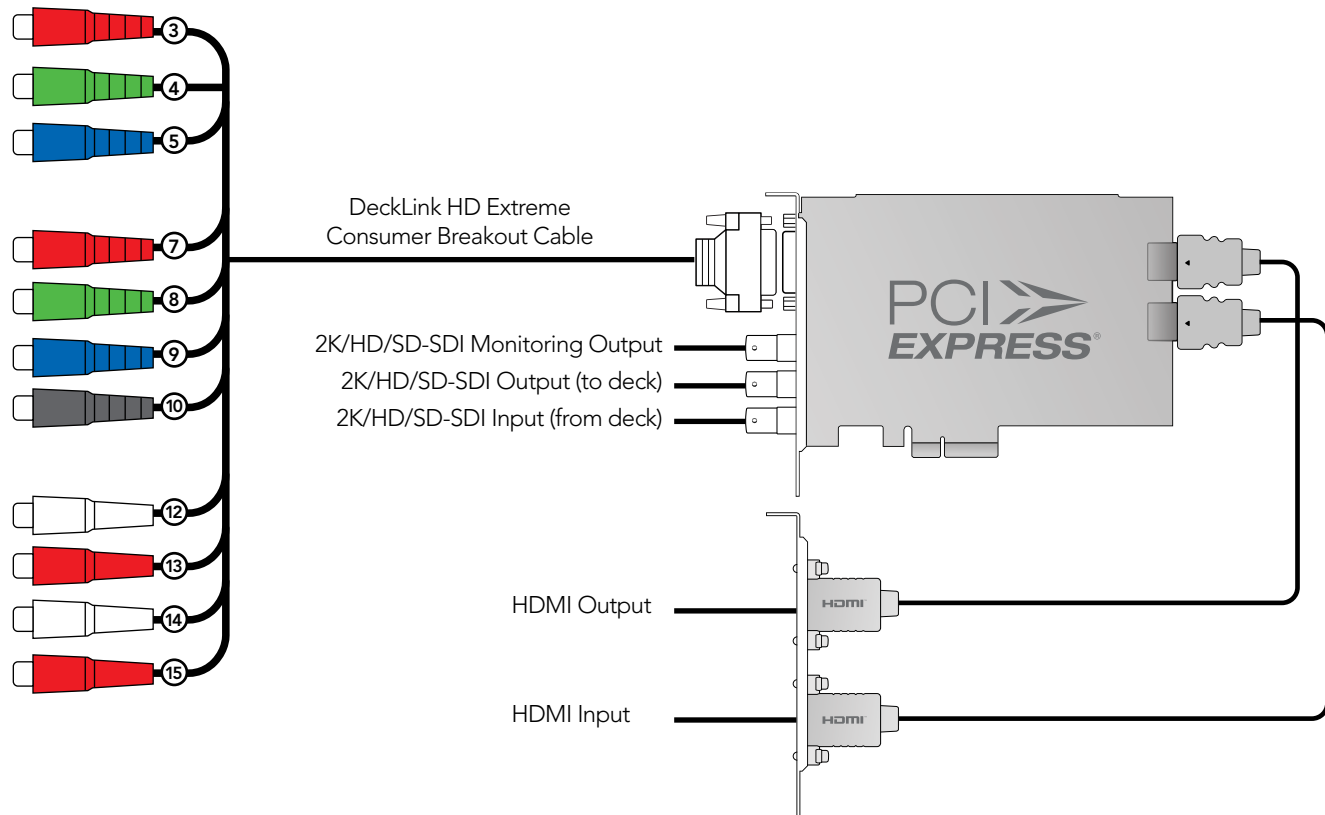

64 Device Diagrams

DeckLink HD Extreme and Professional Breakout Cable

The cable numbering is the same on both the Professional and Consumer Breakout Cables so it's easy to use either cable. For example, component video output uses cables 3, 4 and 5 on both breakout cables.

- 2. Deck Control
- 3. R-Y Out
- 4. Y Out
- 5. B-Y Out
- 6. Ref In
- 7. R-Y In
- 8. Y In
- 9. B-Y In
- 10. AES/EBU Out
- 11. AES/EBU In
- 12. Audio Out Left
- 13. Audio Out Right
- 14. Audio In Left
- 15. Audio In Right

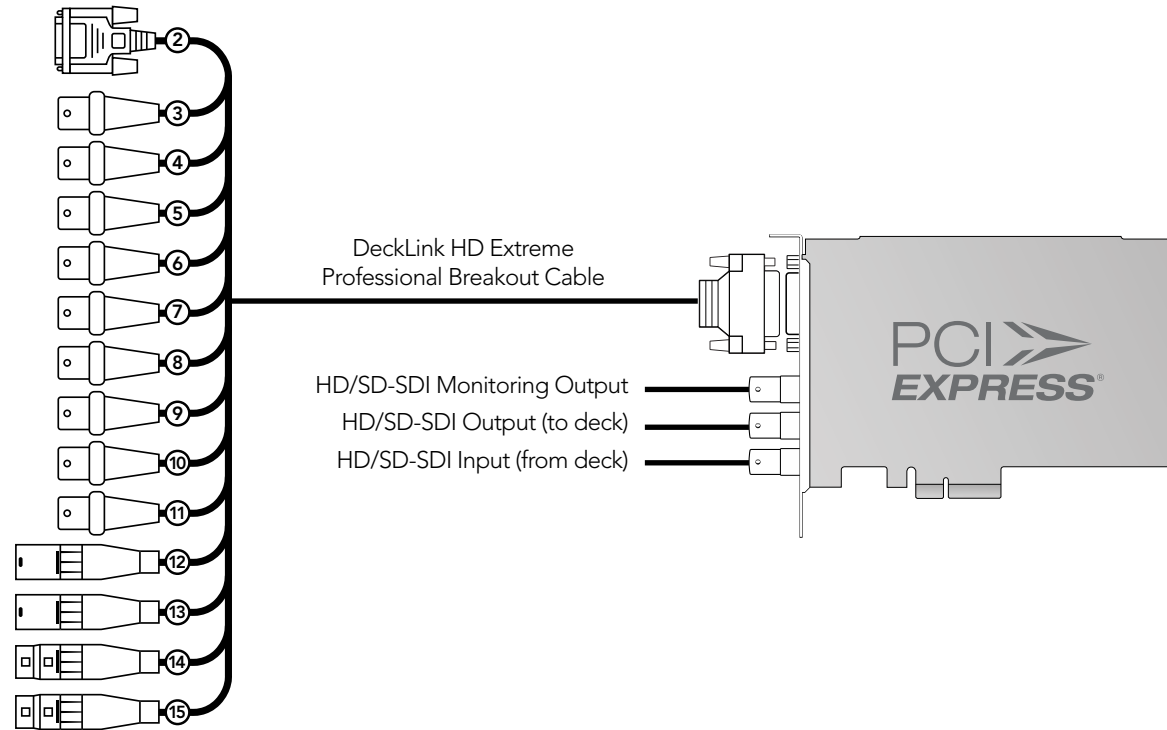

Device Diagrams

DeckLink HD Extreme and Consumer Breakout Cable

The cable numbering is the same on both the Professional and Consumer Breakout Cables so it's easy to use either cable. For example, component video output uses cables 3, 4 and 5 on both breakout cables.

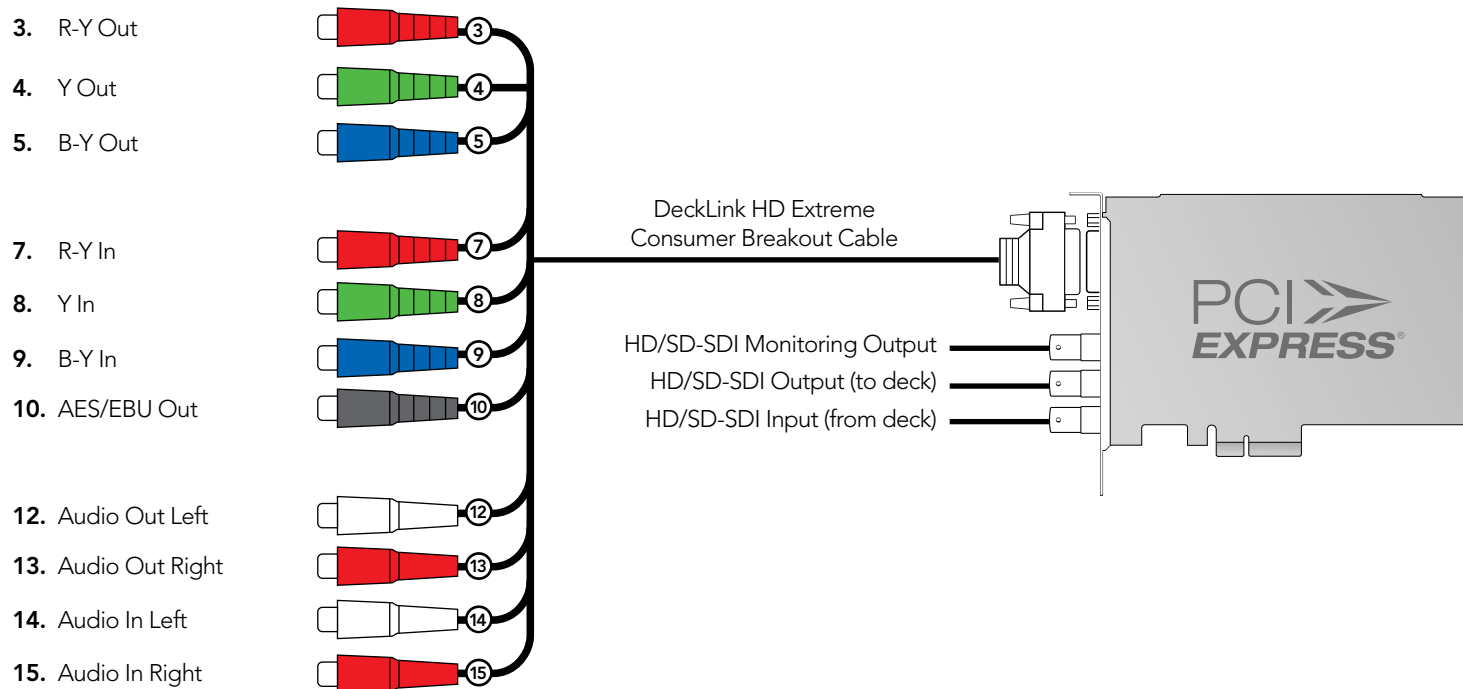

66 Device Diagrams

DeckLink HD Pro PCIe

- 2. Deck Control
- 3. R-Y/R Monitor Out
- 4. Y/G Monitor Out
- 5. B-Y/B Monitor Out
- 6. Ref In
- 7. SPDIF/AES Out
- 8. SPDIF/AES In
- 9. Wordclock Out

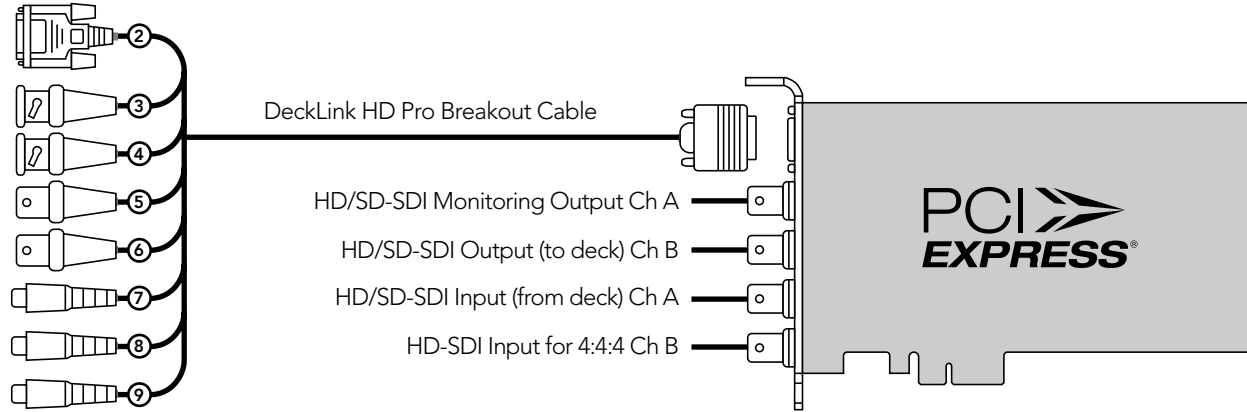

Device Diagrams

DeckLink HD Pro PCI-X

2. Deck Control
3. R-Y/R Monitor Out
4. Y/G Monitor Out
5. B-Y/B Monitor Out
6. Ref In
7. SPDIF/AES Out
8. SPDIF/AES In
9. Wordclock Out

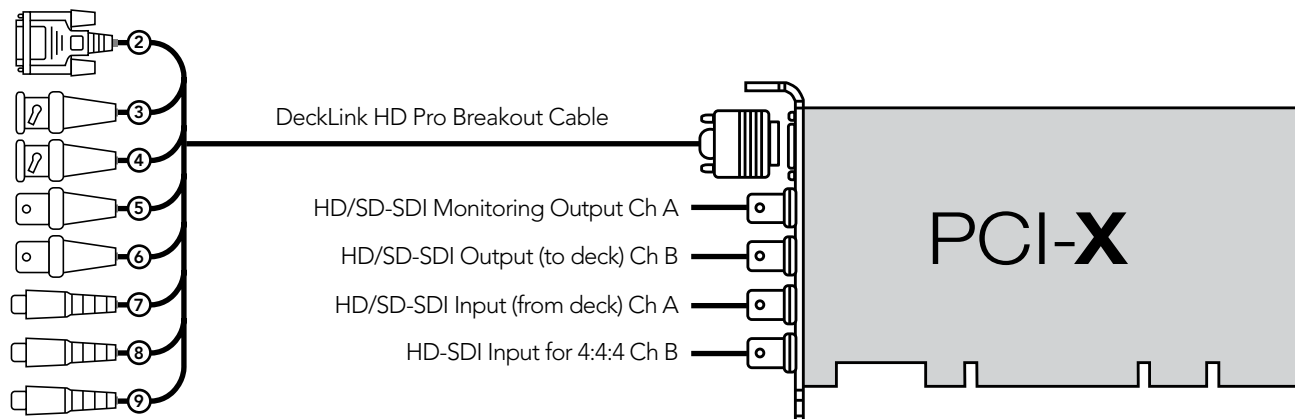

DeckLink Extreme

- 2. AES-S/PDIF Output (monitoring)
- 3. (L) Audio Output (balanced analog)
- 4. (R) Audio Output (balanced analog)
- 5. (L) Audio Input (balanced analog)
- 6. (R) Audio Input (balanced analog)
- 7. Y Input
- 8. B-Y Input
- 9. R-Y Input
- 10. Y Output (composite monitoring)
- 11. B-Y Output
- 12. R-Y Output
- 13. SD-SDI Output
- 14. Genlock Input
- 15. SD-SDI Input
- 16. Deck Control RS-422

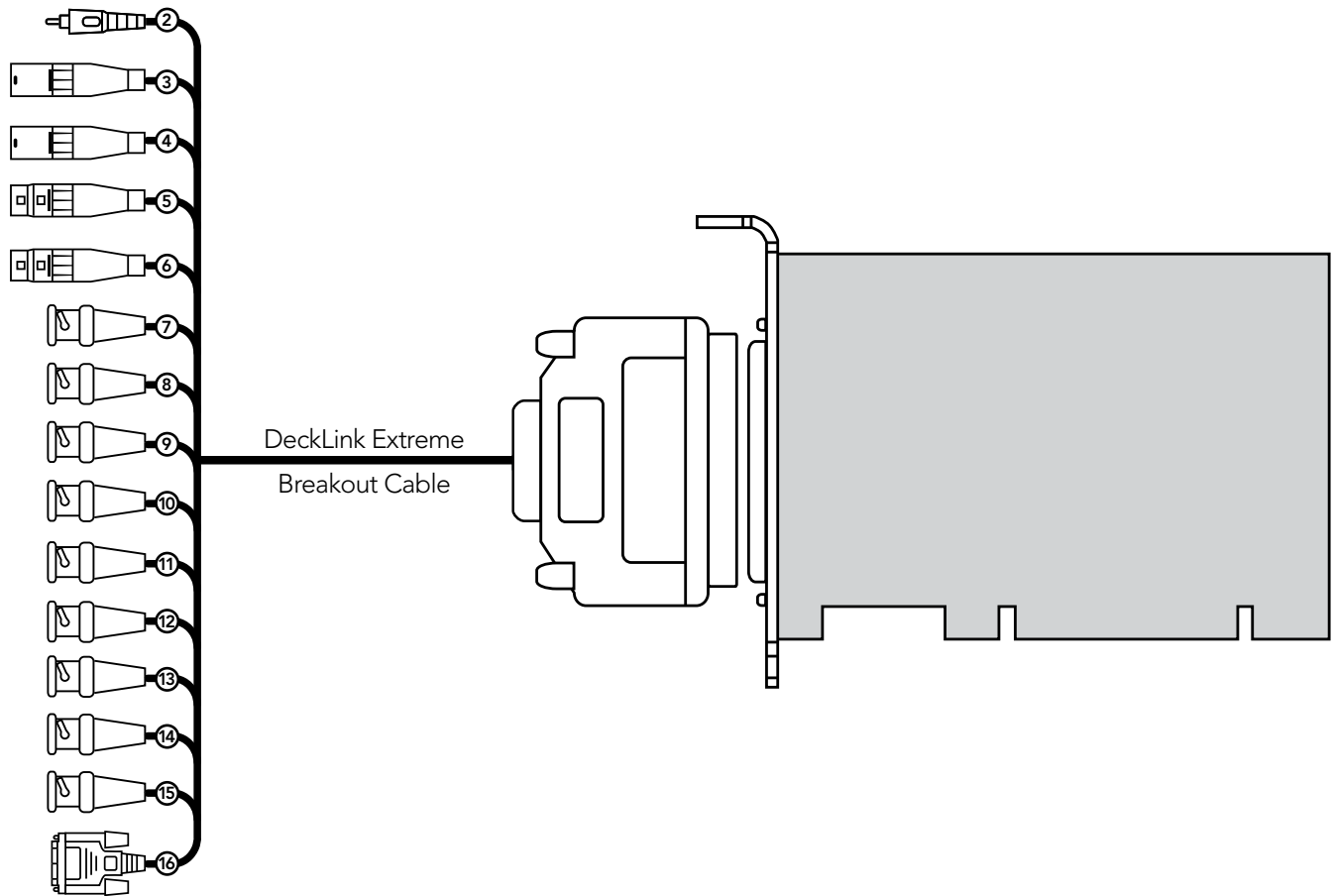

Device Diagrams

DeckLink Extreme PCIe

2. AES-S/PDIF Output (monitoring)
3. (L) Audio Output (balanced analog)
4. (R) Audio Output (balanced analog)
5. (L) Audio Input (balanced analog)
6. (R) Audio Input (balanced analog)
7. Y Input
8. B-Y Input
9. R-Y Input
10. Y Output (composite monitoring)
11. B-Y Output
12. R-Y Output
13. SD-SDI Output
14. Genlock Input
15. SD-SDI Input
16. Deck Control RS-422

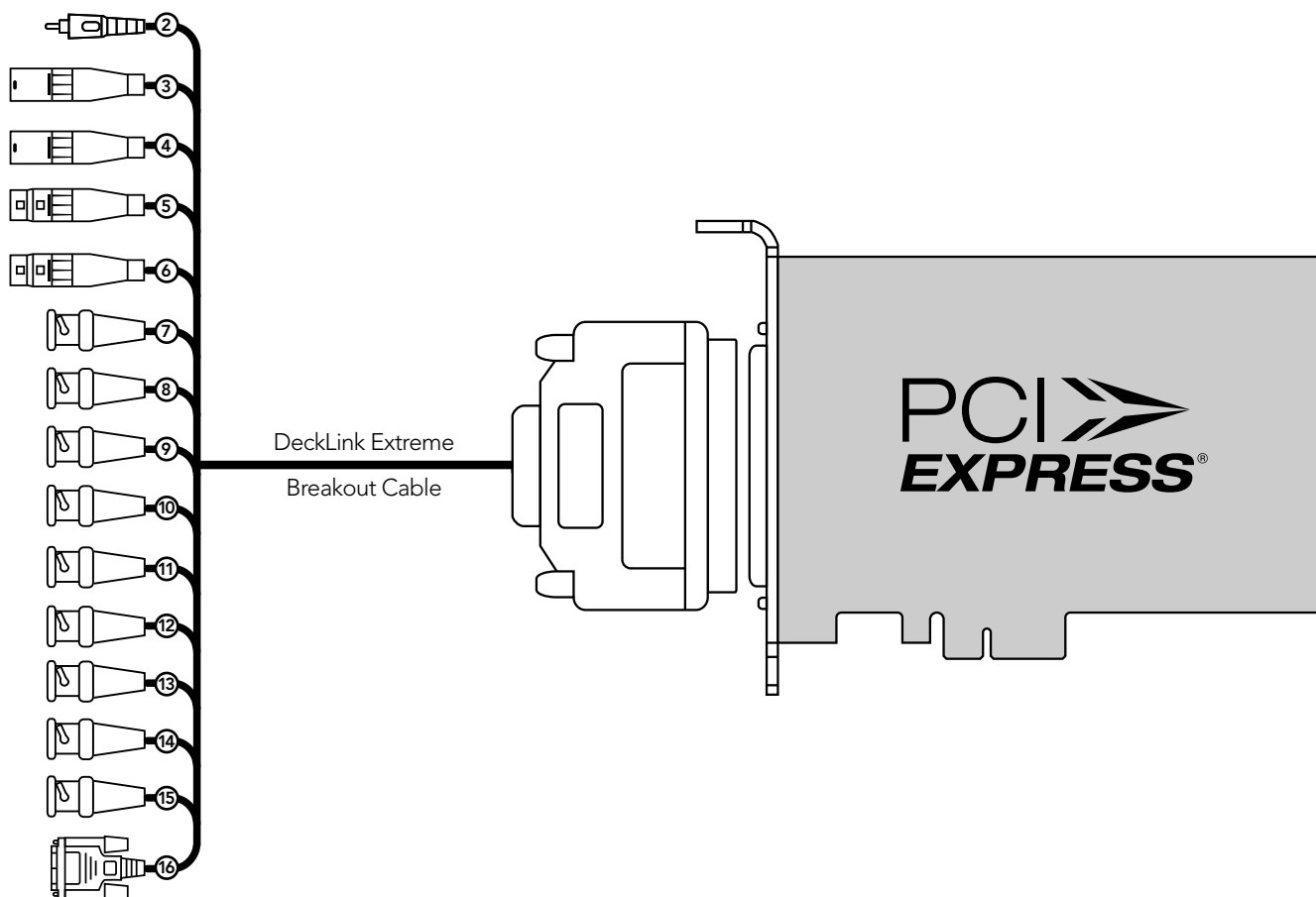

DeckLink SP

- 2. AES-S/PDIF Output (monitoring)
- 3. (L) Audio Output (balanced analog)
- 4. (R) Audio Output (balanced analog)
- 5. (L) Audio Input (balanced analog)
- 6. (R) Audio Input (balanced analog)
- 7. Y Input
- 8. B-Y Input
- 9. R-Y Input
- 10. Y Output (composite monitoring)
- 11. B-Y Output
- 12. R-Y Output
- 13. SD-SDI Output (Monitoring)
- 14. Genlock Input
- 15. Deck Control RS-422

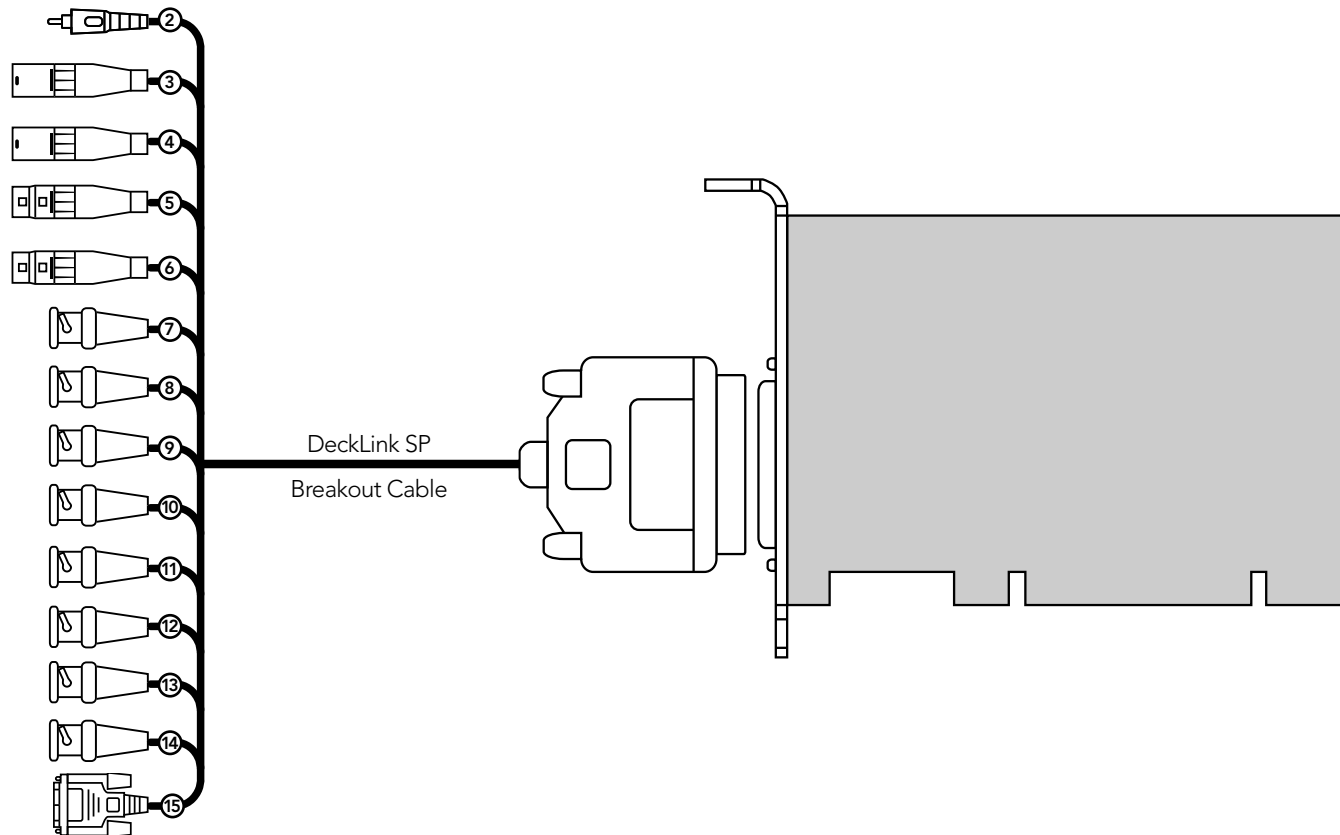

DeckLink SP PCIe

- 2. AES-S/PDIF Output (monitoring)
- 3. (L) Audio Output (balanced analog)
- 4. (R) Audio Output (balanced analog)
- 5. (L) Audio Input (balanced analog)
- 6. (R) Audio Input (balanced analog)
- 7. Y Input
- 8. B-Y Input
- 9. R-Y Input
- 10. Y Output (composite monitoring)
- 11. B-Y Output
- 12. R-Y Output
- 13. SD-SDI Output (Monitoring)
- 14. Genlock Input
- 15. Deck Control RS-422

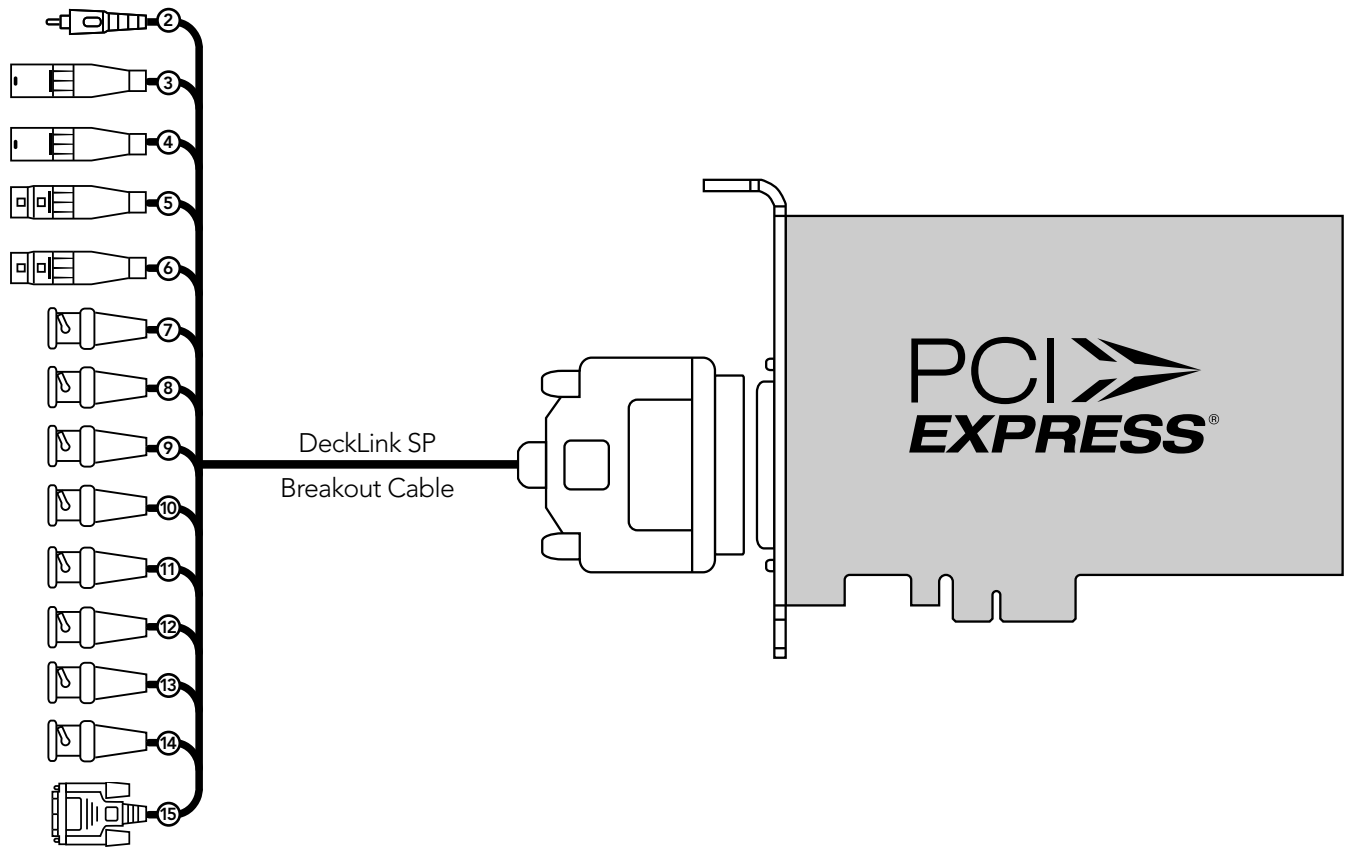

72 Device Diagrams

DeckLink Pro

- 2. AES-S/PDIF Output A (monitoring)
- 3. AES-S/PDIF Output B (monitoring)
- 4. AES-S/PDIF Output C (monitoring)
- 5. AES-S/PDIF Output D (monitoring)
- 6. SDI-SDI Output (Monitoring)
- 7. SD-SDI Output
- 8. SD-SDI Input
- 9. Genlock Input
- 10. Y Output (composite monitoring)
- 11. B-Y Output (Monitoring)
- 12. R-Y Output (Monitoring)
- 13. Deck Control RS-422

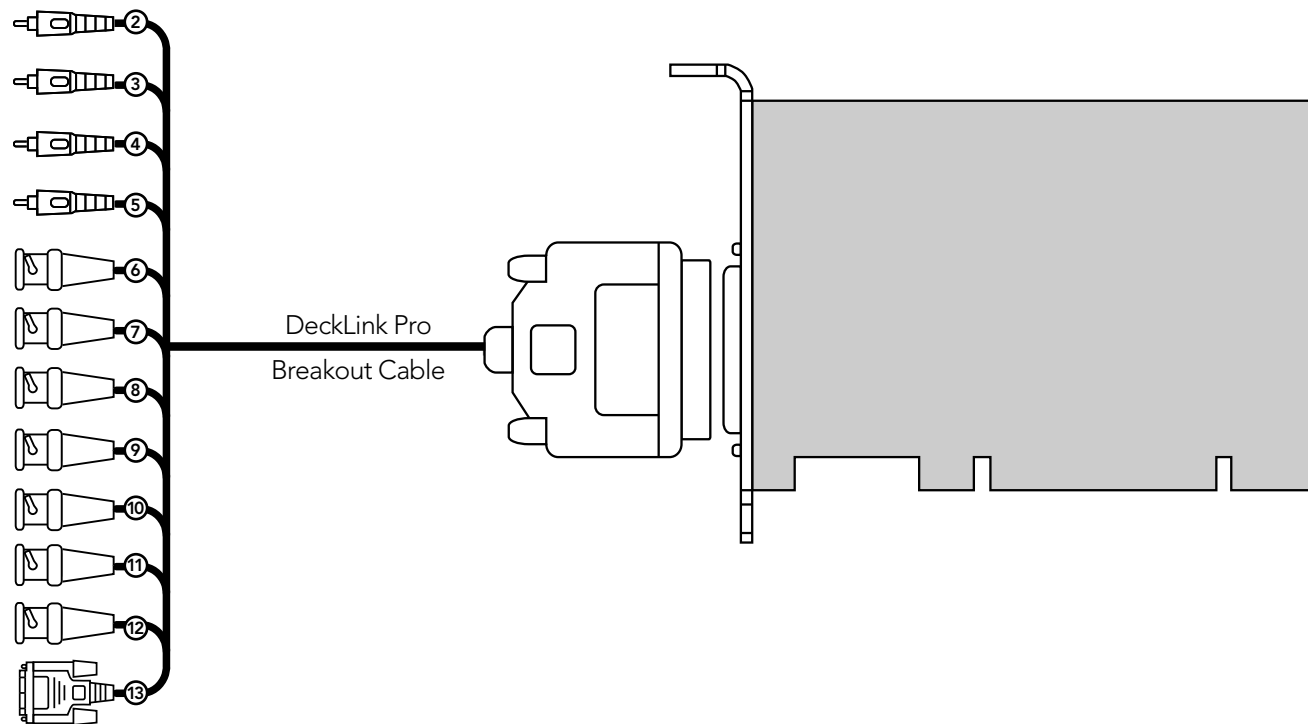

73 Device Diagrams

DeckLink

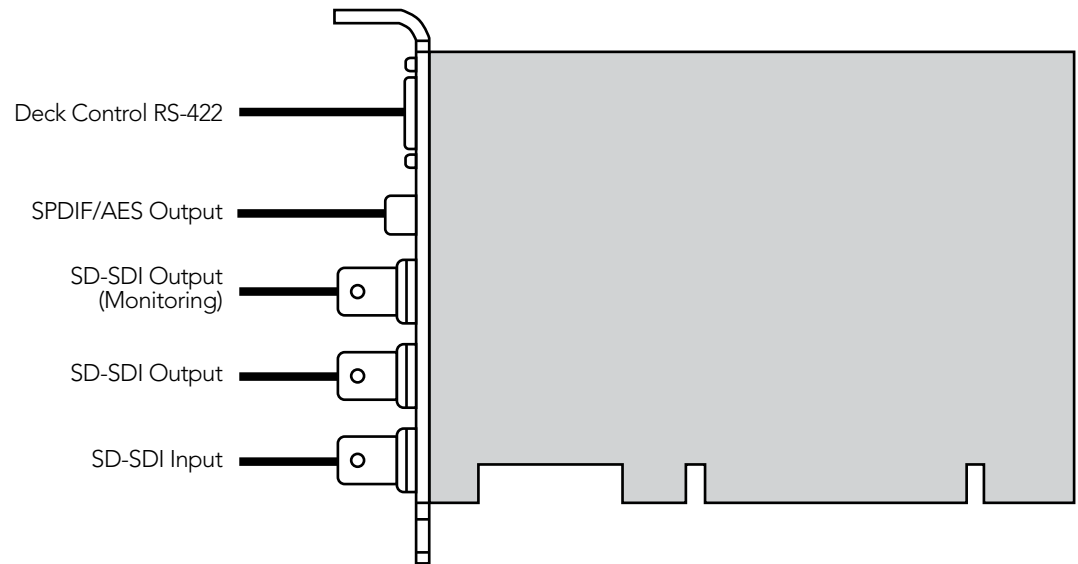

DeckLink Series Operation Manual

12 Month Limited Warranty

12 Month Limited Warranty

Blackmagic Design warrants that this product will be free from defects in materials and workmanship for a period of 12 months from the date of purchase. If a product proves to be defective during this warranty period, Blackmagic Design, at its option, either will repair the defective product without charge for parts and labor, or will provide a replacement in exchange for the defective product.

In order to obtain service under this warranty, you the Customer, must notify Blackmagic Design of the defect before the expiration of the warranty period and make suitable arrangements for the performance of service. The Customer shall be responsible for packaging and shipping the defective product to a designated service center nominated by Blackmagic Design, with shipping charges pre paid. Customer shall be responsible for paying all shipping charges, insurance, duties, taxes, and any other charges for products returned to us for any reason.

This warranty shall not apply to any defect, failure or damage caused by improper use or improper or inadequate maintenance and care. Blackmagic Design shall not be obligated to furnish service under this warranty: a) to repair damage resulting from attempts by personal other than Blackmagic Design representatives to install, repair or service the product, b) to repair damage resulting from improper use or connection to incompatible equipment, c) to repair any damage or malfunction caused by the use of non Blackmagic Design parts or supplies, or d) to service a product that has been modified or integrated with other products when the effect of such a modification or integration increases the time or difficulty of servicing the product. THIS WARRANTY IS GIVEN BY BLACKMAGIC DESIGN IN LIEU OF ANY OTHER WARRANTIES, EXPRESS OR IMPLIED. BLACKMAGIC DESIGN AND ITS VENDORS DISCLAIM ANY IMPLIED WARRANTIES OF MERCHANTABILITY OR FITNESS FOR A PARTICULAR PURPOSE. BLACKMAGIC DESIGN'S RESPONSIBILITY TO REPAIR OR REPLACE DEFECTIVE PRODUCTS IS THE WHOLE AND EXCLUSIVE REMEDY PROVIDED TO THE CUSTOMER FOR ANY INDIRECT, SPECIAL, INCIDENTAL OR CONSEQUENTIAL DAMAGES IRRESPECTIVE OF WHETHER BLACKMAGIC DESIGN OR THE VENDOR HAS ADVANCE NOTICE OF THE POSSIBILITY OF SUCH DAMAGES. BLACKMAGIC DESIGN IS NOT LIABLE FOR ANY ILLEGAL USE OF EQUIPMENT BY CUSTOMER. BLACKMAGIC IS NOT LIABLE FOR ANY DAMAGES RESULTING FROM USE OF THIS PRODUCT. USER OPERATES THIS PRODUCT AT OWN RISK.

Copyright 2009 Blackmagic Design. All rights reserved. 'Blackmagic Design', 'DeckLink', 'HDLink', 'Workgroup Videohub', 'Videohub', 'DeckLink', 'Intensity' and 'Leading the creative video revolution' are registered trademarks in the US and other countries. All other company and product names may be trade marks of their respective companies with which they are associated.