

The logo consists of the numbers '6800' in a bold, sans-serif font, followed by a plus sign. The plus sign is a solid black cross with the word 'PLUS' written in a smaller, bold, sans-serif font across its horizontal bar.

**FR6802+
Frames**

Installation and Operation Manual

Enabling Your
Integrated Content Environment

Integrated Content Environment

Experience an Integrated Content Environment

Leitch Technology is uniquely capable of meeting the needs of customers with a full range of products that provide the experience of an Integrated Content Environment — a streamlined workflow for the production, processing, transmission and management of content.



The area of content production has seen increases in source and output formats, effects, layers and volume of material to be edited. As a result, editors need tools that enable increased productivity to offset these additional time demands, while increasing performance and enhancing creativity.

VelocityQ™ running on Quattrus™ hardware, including a new interface style featuring the unique EyeCon View, has received glowing reviews for its “real-time full-quality” playback speed of four video streams, up to six graphic layers and four 3D DVEs.

Leitch's new NEXIO™ server system, a modular, scalable and highly cost-effective storage infrastructure for news and transmission environments, includes gigabit Ethernet for easy integration with IP networks for movement of content. NEXIO features industry-leading productivity — with the introduction of Ingest Control Manager™, NewsFlash™ server-based NLE, and BrowseCutter™ II low-resolution editing system — to provide the fastest and most effective workflow today.



The advent of fully Integrated Content Environments has led to significant efficiency improvements in workflow, with processing and monitoring now integrated and transparent.

NEO™, Leitch's advanced processing platform, not only hosts single-function modules, but also consolidates multiple functions on a single “Simplicity” card. New award-winning modules have been added with the NEO VR™ digital video recorder, LogoMotion™ II branding tool and the NEO SuiteView multi-source display processor. More functionality can be achieved by customers' infrastructure environments with the high-density 6800+™.

Leitch's industry-leading routing offerings allow customers to connect high-quality signals of all formats from analog to HD. Panacea™ provides affordable, compact, modular routing in sizes up to 32x32. The new wideband Integrator® Gold provides scalable routing of almost any digital signal up to 128x128 in a single frame. All processing and routing platforms are fully integrated with Leitch's advanced Command Control System (CCS™).



Advancements in digital technologies have enabled more channels, in different content formats, over multiple distribution systems. Customers now seek to achieve their vision of a fully Integrated Content Environment to supply multiple distribution channels with high-quality content and branding.

Leitch's NEXIO transmission server, which supports multiple compression formats in both standard and high-definition resolution, will also support ASI interface and has the ability to record, process and playback MPEG transport streams.

Leitch's Opus™ master control switcher offers an array of effects and has the ability to control up to 16 on-air channels. Opus meets multi-channel digital integration challenges for both high-definition and standard-definition formats.



Integrated Content Environments offer the greatest opportunity for productivity and performance gains when employing content management and control applications that place content, operations or remote locations under common software controls.

A major workflow enhancement is Leitch's Ingest Control Manager™, which places control of up to 16 server channels with associated proc amps (DPS-575), eight VTRs and eight separate routers under one control station.

Leitch's CCS Navigator™, winner of NAB 2003's highest awards for control and monitoring of content quality, and the CCS™ soft real-time system provide open access through standard protocols to components of a networked system.

FR6802+

Frames

Installation and Operation Manual

Preface

Manual Information

Purpose

This manual details the features, installation procedures, operational procedures, and specifications of the FR6802+ Frames.

Audience

This manual is written for engineers, technicians and operators responsible for the installation, setup, and/or operation of FR6802+ Frames.

Revision History

Table P-1. Revision History

Edition	Date	Revision History
A	May 2003	Initial release
B	January 2005	Addition of 6802+PS DC information as well as minor corrections to content
C	February 2005	Addition of index and module card-edge navigation information

Writing Conventions

To enhance your understanding, the authors of this manual have adhered to the following text conventions:

Table P-2. Manual Writing Conventions

Term or Convention	Description
Bold	Indicates dialog boxes, property sheets, fields, buttons, check boxes, list boxes, combo boxes, menus, submenus, windows, lists, and selection names.
<i>Italics</i>	Indicates email addresses, the names of books or publications, and the first instances of new terms and specialized words that need emphasis.
CAPS	Indicates a specific key on the keyboard, such as ENTER, TAB, CTRL, ALT, or DELETE.
Code	Indicates variables or command-line entries, such as a DOS entry or something you type into a field.
>	Indicates the direction of navigation through a hierarchy of menus and windows.
hyperlink	Indicates a jump to another location within the electronic document or elsewhere
Internet address	Indicates a jump to a Web site or URL
 Note	Indicates important information that helps to avoid and troubleshoot problems.

Obtaining Leitch Documents

Leitch documents can be viewed or downloaded from the Leitch Web site at www.leitch.com (go to **Support>Documentation**). Alternatively, contact your Leitch customer service representative to request a document.

Unpacking/Shipping Information

Leitch has carefully inspected, tested, and calibrated this product before shipment to ensure years of stable and trouble free service.

1. Check equipment for any visible damage that may have occurred during transit.
2. Confirm that you have received all items listed on the packing list.
3. Contact your Leitch dealer if any item on the packing list is missing.
4. Contact the carrier if any item is damaged.
5. Remove all packaging material from the product and its associated components before you install the unit.

Keep at least one set of original Leitch packaging, in the event that you need to return a product for servicing. If the original packaging is not available, you can purchase replacement packaging from Leitch at a modest cost or supply your own packaging as long as it meets the following criteria:

- Withstands the weight of the product
- Holds the product rigid within the packaging
- Leaves at least 2 in. (50.8 mm) of space between the product and the container
- Protects the corners of the product



Ship products back to Leitch for servicing prepaid and, if possible, in the original packaging material. If the product is still within the warranty period, Leitch will return the product prepaid after servicing.

Safety Standards and Compliances

See the 6800+ Safety Instructions and Standards Manual to find the safety standards and compliances for this 6800+ series product. A safety manual is shipped with every *FR6802+ Frames Installation and Operation Manual* and can be downloaded from the Leitch Web site at www.leitch.com. Alternatively, contact your Leitch customer service representative for a copy of this safety manual.

Safety Terms and Symbols

This product manual uses the following safety terms and symbols to identify certain conditions or practices. See the *6800+ Safety Instructions and Standards Manual* for more information.

	WARNING: Identifies conditions or practices that can result in personal injury or loss of life—high voltage is present. Uninsulated dangerous voltage within the product’s enclosure may be sufficient to constitute a risk of electric shock to persons.
	CAUTION: Identifies conditions or practices that can result in damage to the equipment or other property. Important operating and maintenance (servicing) instructions are included in the literature accompanying the product.

Contents

Preface

Manual Information	iii
Purpose	iii
Audience	iii
Revision History	iii
Writing Conventions	iv
Obtaining Leitch Documents	iv
Unpacking/Shipping Information	v
Safety Standards and Compliances	vi
Safety Terms and Symbols	vi

Chapter 1: Introduction

Overview	1
Product Description	2
6800+ Products	2
FR6802+ Frames	2
6800 and 6800+ Co-Existence	3
Available Frame Configurations and Back Panel Types	3
Main Features	4
Signal Flow	5
Front Panel Description	6
Rear Panel Description	7
Fan Assembly Description	8
Power Supply Description	9
Resource Card Description	10
Communications and Control	11
Serial Control	11

Ethernet Control	12
------------------------	----

Chapter 2: Installation and Operation

Overview	13
Maximum 6800+ Frame Power Ratings	14
Checking the Packing List	15
Meeting Location Requirements	16
Ensuring Proper Temperature and Ventilation	16
Meeting Electrical Requirements	16
Installing the Frame in a Rack	18
Ensuring Adequate Rack Space	18
Attaching Optional Rear-Support Brackets	18
Installing 6800+ Modules	21
Installing 6800+ Modules in an FR6802+ Series Frame	22
Installing 6800+ Modules into a 6800/7000 Series Frame	25
Making Connections	26
Removing 6800+ Modules	26
Installing Fans	27
Upgrading to an FR6800+F Frame	27
Replacing a Failed Fan Unit	29
Making System Connections	32
Connecting to a Power Source	32
Making Genlock Connections for Signal Synchronization	33
Creating a Serial Communication Network	34
Connecting the GPI Alarm Relay to a Monitoring System	36
Connecting to a CCS Network	36
Operating the Frame	37
Reviewing the Steps	37
Understanding Status LEDs	38
Understanding Card-Edge Controls	39
Introducing Control Types	39
Introducing Parameter Types	40
Operating Installed Modules	42
Operating Notes	42

Chapter 3: 6802+PS and 6802+PS48 Power Supplies

Overview	43
Installing a Power Supply	44

Disconnecting and Removing an Existing Power Supply	44
Installing a New Power Supply	45
Protecting the Power Supply	45
Understanding Alarm Signals and Indicators	46

Chapter 4: Specifications

Overview	47
Frame Specifications	48
Power Supply Specifications	48
6802+PS	48
6802+PS48	50

Appendix A: Servicing Instructions

Overview	53
Battery Use Caution	54
Fuse Replacement Caution	55
Replacing a Resource Card	56
Removing an Existing Resource Card	56
Installing a New Resource Card	56

Index

Keywords	57
----------------	----

Introduction

Overview

The *FR6802+ Frames Installation and Operation* manual describes the FR6802+ series of frames, outlines their specifications, and details the procedures for installation, configuration, and operation.

This chapter introduces the FR6802+ 2RU series of frames, and briefly describes their main features. The following topics are found in this chapter:

- “Product Description” on page 2
- “Main Features” on page 4
- “Signal Flow” on page 5
- “Front Panel Description” on page 6
- “Rear Panel Description” on page 7
- “Fan Assembly Description” on page 8
- “Power Supply Description” on page 9
- “Resource Card Description” on page 10
- “Communications and Control” on page 11

Product Description

6800+ Products

Reliable, dependable, and easy to use, 6800+ products combine high performance and exceptional quality with adaptable, cost-effective solutions.

6800+ is an extension of features, an expansion of use, and an increase of performance to the solid operation you have come to know and trust in the 6800 name. Leitch invented the modular-platform; now we have again redefined the industry with an offering that resets the standard.

- 6800+ Capacity: Up to 20 modules
- 6800+ Compatibility: HD, SD, Analog (audio/video), Fiber Optics
- 6800+ Continuity: Housing all existing 6800 products
- 6800+ Control: Providing free serial and optional Ethernet control

It is everything you value about 6800...plus more.

FR6802+ Frames

The 2RU FR6802+ frames accommodate the entire 6800 line of analog/digital, audio/video products for conversion, distribution, interface, generation, and router applications. In addition, the FR6802+ frames expand the product offerings to include virtually any application in the modular arena. All interface mechanics are supported.

The new FR6802+ frames provide central genlock distribution, GPI for alarms, two types of remote control interfaces, 20-slot capacity and support for multi-standard products (including HD, SD, analog, and fiber optics), and high power operation. Addressing space considerations, it sets no cooling limits on multiple frames stacked together, and is specifically designed to weigh noticeably less than other products. Each feature has been carefully designed to ensure a product that is reliable, dependable and easy-to-use.

All FR6802+ frames come with absolutely free serial control. An optional interface to Ethernet is also available, allowing connectivity with all other Leitch CCS-controlled products.

6800 and 6800+ Co-Existence



Note

CCS software applications and control panels will not recognize 6800+ modules when they are installed in existing 6800 frames

FR6802+ frames are designed to house and power both 6800 and the 6800+ modules. Although the 6800+ modules have different features and controls, both work in harmony with each other in the evolved FR6802+ frames.

Likewise, 6800+ modules that use the 6800-style connector interface (with 9 BNCs) can be directly used in existing 6800 frames.

Available Frame Configurations and Back Panel Types

There are several FR6802+ frame products and packages available. For example, depending on your frame configuration and product needs, you can order an empty back panel to accommodate an assortment of individual back connectors or a solid (full) back panel to accommodate either 10 double-width or 20 single-width modules.

Some members of the FR6802+ family include the following:

Table 1-1. FR6802+ Frames and Accessories

Product Code	Description
FR6802+X	2RU frame; includes blank back connectors and one 6802+PS AC power supply
FR6802+X48	Same as above, except includes one DC power supply unit (PSU)
FR6802+XF	2RU frame; includes blank back connectors, one 6802+PS AC power supply and fan assembly
FR6802+XF48	Same as above, except includes one DC power supply
FR6802+DM	2RU frame; includes a full double-slot back panel with 10 back connectors (100 BNC metal connectors) and one 6802+PS AC power supply
FR6802+DM48	Same as above, except includes one DC power supply
FR6802+DMF	Same as FR6802+DM, except includes fan assembly
FR6802+DMF48	Same as FR6802+DM48, except includes fan assembly
6802+FA	Fan assembly for 2RU frame
6802+PS	Redundant, single 6800+ AC power supply
6802+PS48	Redundant, single 6800+ DC power supply

Main Features

FR6802+ frames have the following main features:

General Frame

- Works with most 6800 modules (using a “6800-style” rear module) and with 6800+ modules
- Configurable to a wide variety of multi-standard audio and video conversion, routing, generation, and distribution module combinations (HD, SDI, audio, fiber optics)
- Provides space for 10 double-slot modules, 20 single-slot modules, or a combination of both double- and single-slot modules
- Provides looping reference input for video genlock, with buffered reference distribution to all modules

Thermal/Fan

- Provides refined fan-cooling for a ≤ 120 W load for AC power supply, or ≤ 105 W load for DC power supply
- Cools modules using a front-to-back airflow with alarm-monitored, low-noise fans

Control and Monitoring

- Provides an RS-232 serial connection for basic control and monitoring
- Provides access to the Ethernet for more robust control and monitoring using an optional interface module (ICE6800+)
- Regulates and reports major frame operation and performance data to the control system via a resource card

Power Supply

- Houses two power supplies for full redundancy and load-sharing
- Displays power and fault indicators on front panel
- Includes captivated power cord(s) for AC power supplies to prevent accidental unplugging (note: cords are not provided for the DC power supply configurations)
- Provides choice of 6802+PS for AC power or 6802+PS48 for DC power; frame can house two of either power supply or one of each

Signal Flow

Figure 1-1 illustrates the signal flow of FR6802+ frames:

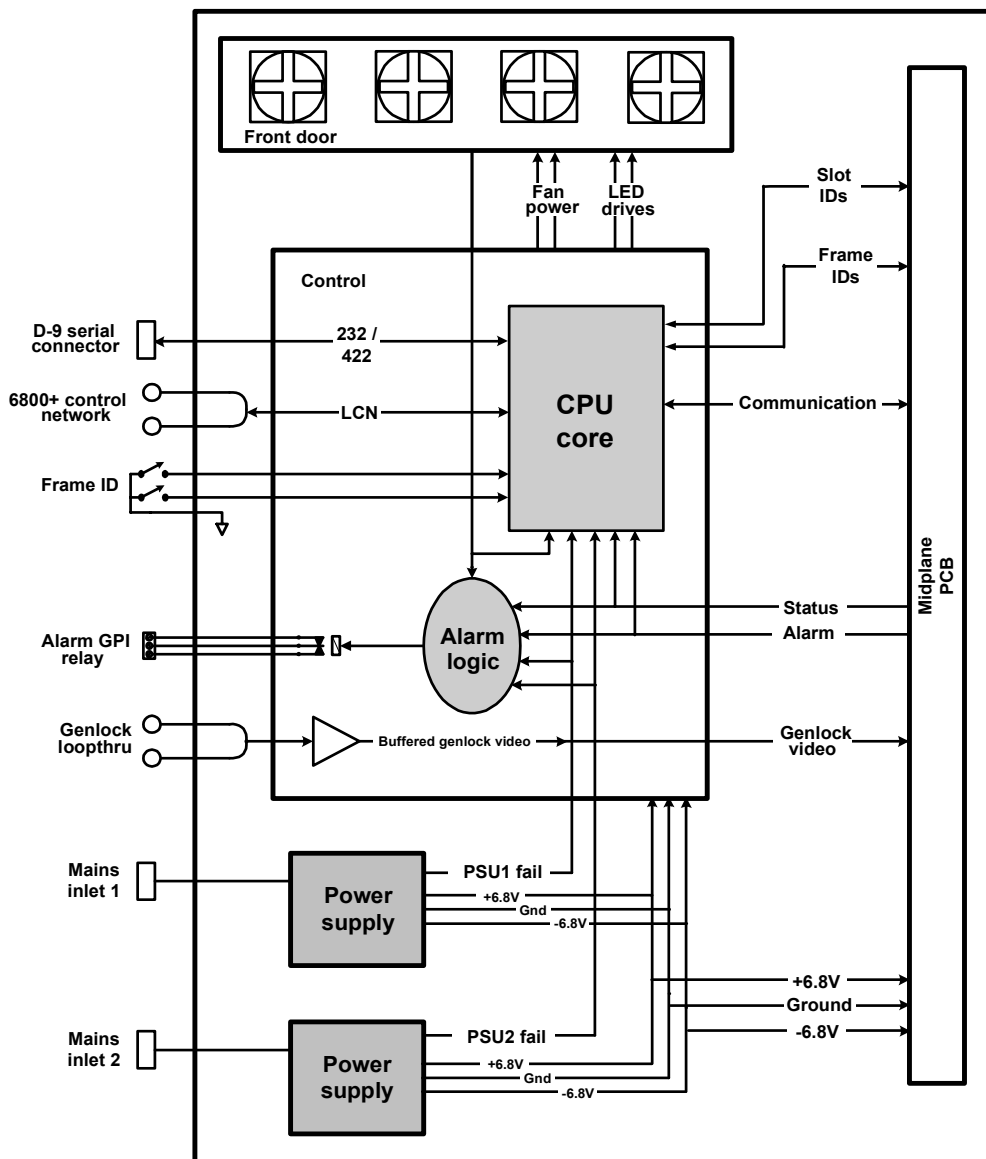

Figure 1-1. Signal Flow Diagram

Front Panel Description

Figure 1-2 shows the front view of a FR6802+ frame, and identifies the location of status LEDs, cooling fans, and front panel release screws.

Figure 1-3 shows the inside of the frame with the front panel removed.

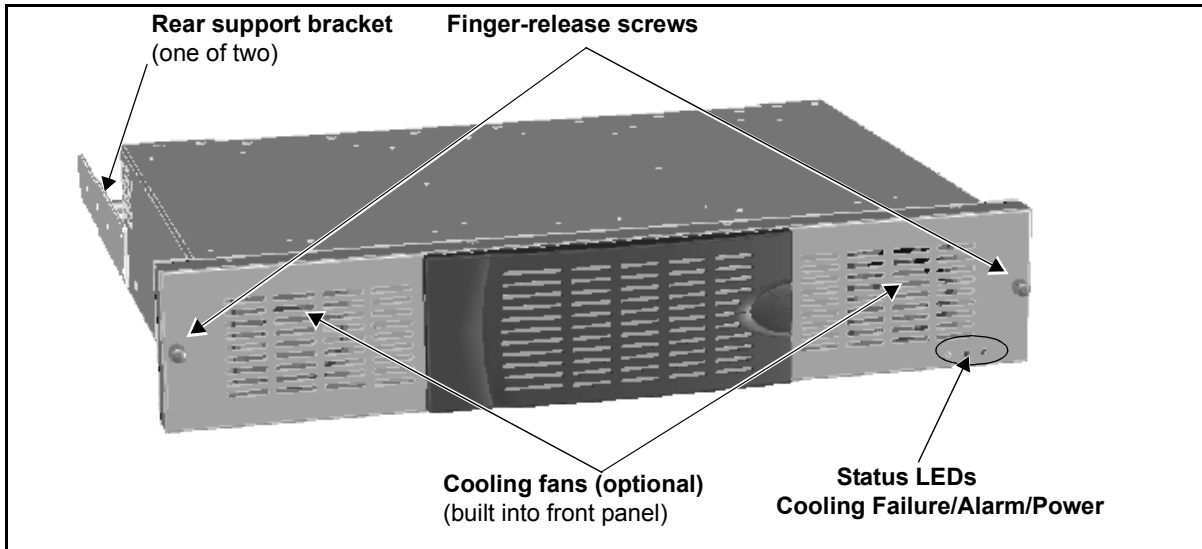

Figure 1-2. FR6802+Frame Front Panel

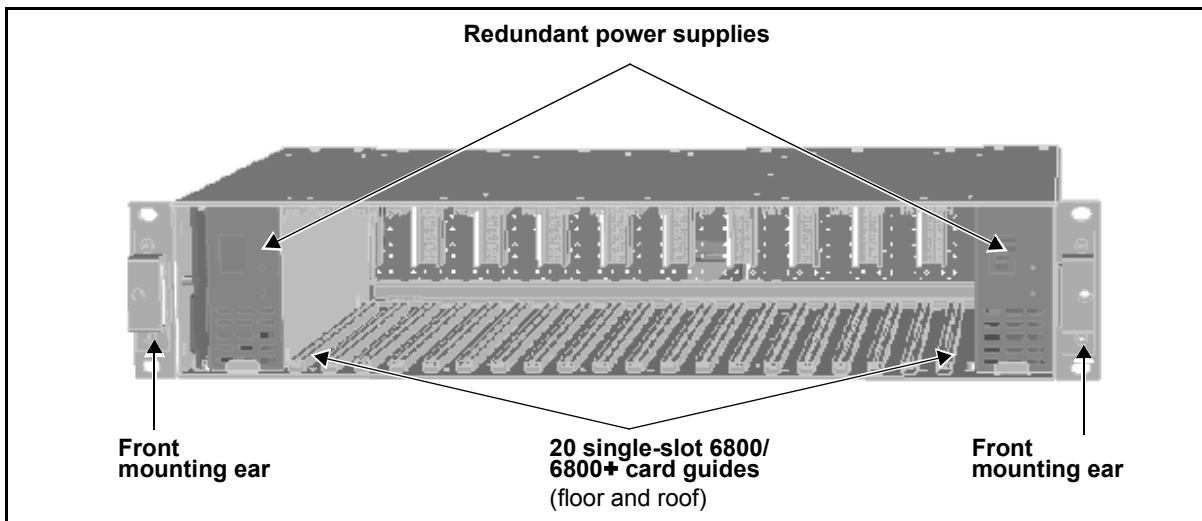

Figure 1-3. FR6802+ Frame with Front Panel Removed

Rear Panel Description

Figure 1-4 identifies the location of FR6802+ rear panel components. Table 1-2 briefly describes each of the connectors and switches found on the rear panel. See “Making System Connections” on page 32 for more information on system connections.

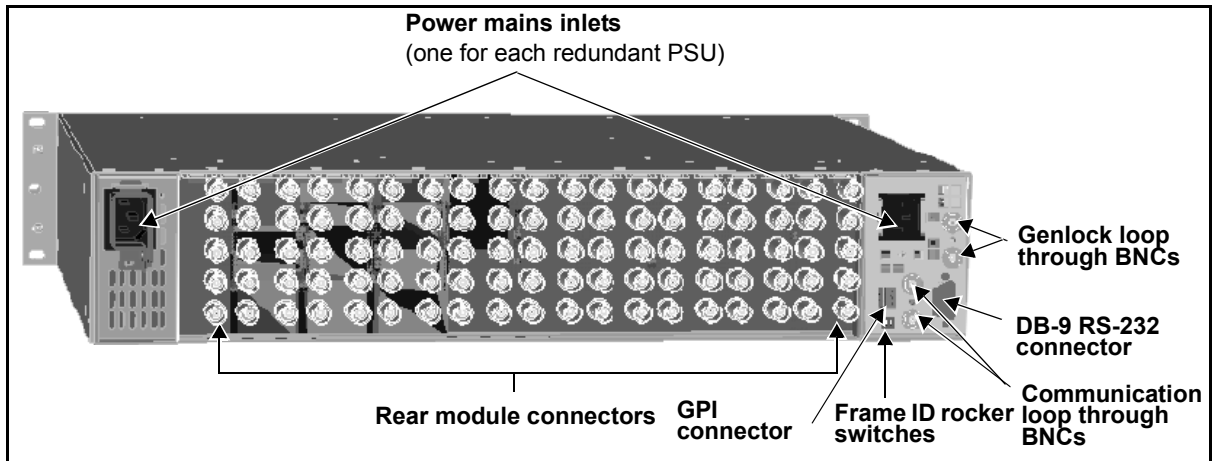

Figure 1-4. FR6802+ Frame Rear Panel

Table 1-2. Rear Panel Components

Item	Description
Power mains inlets	Independent power source connections
GPI connector	Alarm relay connection between an FR6802+ frame and a third-party control monitoring system
Frame ID rocker switches	Unique frame identification switch (four possible frame ID combinations)
Communication loop through BNCs (COM LOOP)	Communication network input/output serial connections for chained frames
DB-9 RS-232 connector	Serial communication link between a PC and an FR6802+ frame
Genlock loop through BNCs	Video synchronization connections

Fan Assembly Description

An optional fan assembly is located in the front panel of an FR6802+ frame (see [Figure 1-5](#)). The fan assembly draws in air from the front of the unit, and expels it through the back.



Figure 1-5. Fan Assembly (Back View of Front Panel)

All fans are equipped with RPM monitoring circuitry. The FR6802+ resource card decodes and monitors these signal to determine fan health. Local and remote alarms report undesirable conditions that may arise.

Features of the FR6802+ fan assembly include the following:

- Low fan-noise emissions
- Alarm RPM monitoring and recording
- Alarm bus reporting of fan failure
- Automatic fan shut-down when front panel is removed

FR6802+ frames can be ordered without a fan assembly for low-power applications (maximum 50 W). If you have a frame configuration that consumes over 50 W, you will need a fan assembly to prevent overheating and ensure proper system operation.

Power Supply Description

Each FR6802+ frame can house two redundant, modular, and fully self-contained power supply units (PSU). All FR6802+ frames come with one AC or DC power supply, which can support an entire frame load. An optional redundant AC or DC power supply can be ordered separately. Power supply configurations can be a mix of AC and DC units.

Each PSU is hot-swappable, ensuring no disruption to frame operation. Other features of both power supplies include the following:

- Allows frame monitoring of PSU
- Includes power switch on front of PSU unit
- Maintains compatible output rails ± 6.8 V for 6800 and 6800+ products

The 6802+PS auto-switches 90 to 240 V AC, at 47 to 63 Hz. “Power” and “Fault” indicators are located on the front of the PSU.

The 6802+PS48 supports a -48 VDC input and provides DC PSU protections including input fuse, inrush current limiting, input transient protection, short circuit protection on all outputs, and reverse input voltage protection. It provides a Power Good green LED and an Overheat red LED.

See [Figure 1-3 on page 6](#) to locate the PSU units in the FR6802+ frame, or “[Chapter 3: 6802+PS and 6802+PS48 Power Supplies](#)” for a more detailed description.

Resource Card Description

The resource card installed in every FR6802+ frame regulates and reports major frame operation, functionality, and status particulars to the control system. The resource card acts as an interface to the control system and provides interconnectivity to logical and coaxial control networks. Monitoring responsibilities include the following:

- Fan health monitoring
- Alarm state reporting for status bus and front-panel closure
- Monitoring and reporting of frame status particulars to the control system

See [“Appendix A: Servicing Instructions”](#) for information on locating, removing, and installing resource cards.

Communications and Control

FR6802+ frames have two methods for communication and control: serial (standard), and Ethernet (optional).

Serial Control

By creating a serial connection between FR6802+ frames and a PC running the +Pilot Lite software application, you can monitor and control every frame and its installed devices from the PC. Using BNC coaxial cables, you can connect up to four FR6802+ frames to create a network where input and output signals are shared. Then, using an RS-232 null modem serial cable connection, connect one of the frames to the PC. This communication and control method is a standard feature on all FR6802+ frames. See [“Creating a Serial Communication Network” on page 34](#) for more detailed instructions.

Figure 1-6 shows a typical system configuration.



Note

Termination is not required for a single frame connected with an RS-232 cable to a PC.

Termination is only required in system configurations with multiple frames.

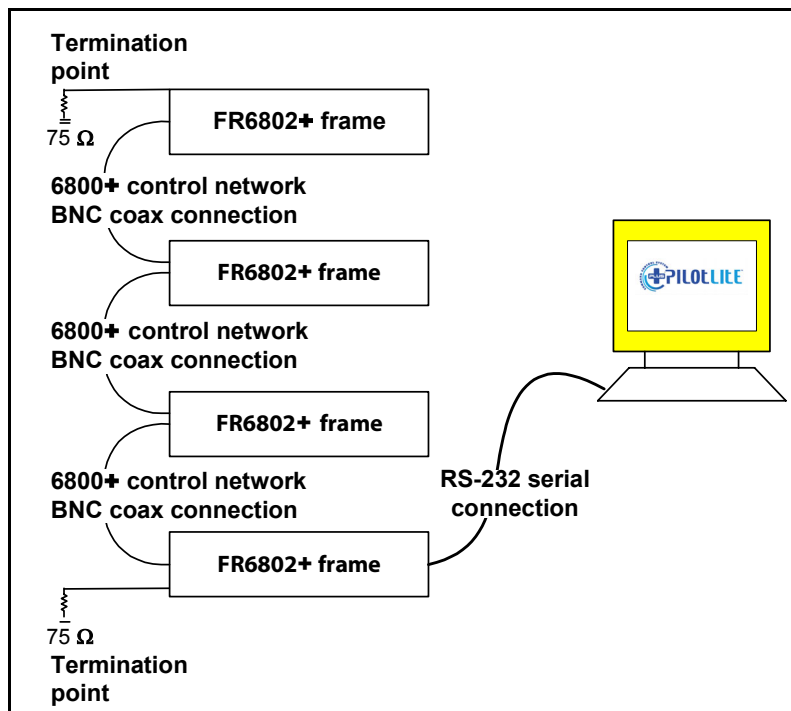

Figure 1-6. Typical System Configuration for Serial Control

Ethernet Control

Using the optional ICE6800+ Interface Card to Ethernet module, you can remotely control and monitor up to nine FR6802+ frames using Leitch Command Control System (CCS™) software applications such as Pilot or Navigator. The ICE6800+ module provides 10 Mb Ethernet access, while the CCS software application provides a general user interface (GUI) to the serial connection. See the *ICE6800+ Interface Card to Ethernet Installation and Operation Manual* for more information.

Figure 1-7 shows a typical system configuration.

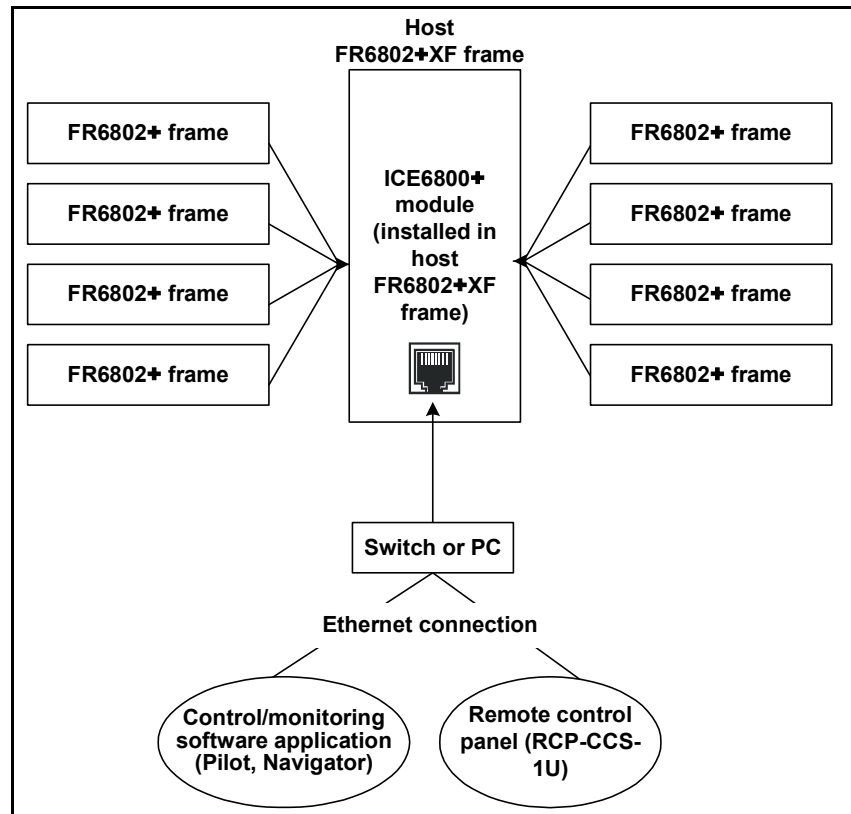

Figure 1-7. Typical System Configuration for Ethernet Control

Installation and Operation

Overview



Caution

Before installing a 6800+ module, see [“Maximum 6800+ Frame Power Ratings”](#) on page 14.

This chapter describes FR6802+ series frame and module installation and operation procedures, including unpacking, meeting environmental and electrical requirements, connecting and operating a frame, and using controls on a 6800+ module card-edge.

The following topics are found in this chapter:

- [“Maximum 6800+ Frame Power Ratings”](#) on page 14
- [“Checking the Packing List”](#) on page 15
- [“Meeting Location Requirements”](#) on page 16
- [“Installing the Frame in a Rack”](#) on page 18
- [“Installing 6800+ Modules”](#) on page 21
- [“Removing 6800+ Modules”](#) on page 26
- [“Installing Fans”](#) on page 27
- [“Making System Connections”](#) on page 32
- [“Operating the Frame”](#) on page 37
- [“Understanding Card-Edge Controls”](#) on page 39
- [“Operating Installed Modules”](#) on page 42

See [page 43](#) for information on installing 6802+PS or 6802+PS48 power supplies.

Maximum 6800+ Frame Power Ratings

Table 2-1 and Table 2-2 describe the maximum allowable power ratings for 6800+ frames.

Table 2-1. Maximum Power Ratings for 6800+ Frames When Using an AC Power Supply

6800+ Frame Type	Max. Frame Power Dissipation	Number of Usable Slots	Max. Power Dissipation Per Slot
FR6802+DM (frame without fans)	50 W	10	5 W
FR6802+DMF (frame with fans)	120 W	10	12 W
FR6802+X (frame without fans)	50 W	20	2.5 W
FR6802+XF (frame with fans)	120 W	20	6 W

Table 2-2. Maximum Power Ratings for 6800+ Frames When Using a DC Power Supply

6800+ Frame Type	Max. Frame Power Dissipation	Number of Usable Slots	Max. Power Dissipation Per Slot
FR6802+DM48 (frame without fans)	50 W	10	5.0 W
FR6802+DMF48 (frame with fans)	105 W	10	10.5 W
FR6802+X48 (frame without fans)	50 W	20	2.5 W
FR6802+XF48 (frame with fans)	105 W	20	5.25 W

Checking the Packing List



Note

See “Unpacking/Shipping Information” on page v for pre-installation information.

The FR6802+ frame is packed in a box with these items:

- One FR6802+ frame
- One power supply unit (installed)
- One AC power cord (if the frame contains an AC power supply; no cords are shipped with DC units)
- Sufficient blank back connectors, as required
- One *Installation and Operation Manual* for each of the installed front module/back connector product packages
- One *FR6802+ Frame Installation and Operation Manual*
- One *6800+ Series Safety Instructions and Standards Manual*

Options

- Additional power supply unit (installed)
- Additional AC power cord for a second AC PSU (no cords are provided for DC power supplies)
- Back connector product packages (installed)
- One left and one right rear support bracket, each with a corresponding slotted bracket
- One cable support bar

Meeting Location Requirements

Ensuring Proper Temperature and Ventilation



Caution

To ensure proper ventilation, keep the front panel of the frame closed during operation, and install blank back connectors behind empty module slots. The frame will overheat if you do not observe this precaution.

The FR6802+ frame is cooled by forced air that is drawn in from the front and expelled through the rear. You can stack any number of FR6802+ frames in a rack as long as you maintain proper ventilation and remove all obstructions to air flow.

Ambient temperature should be maintained at between 32°F (0°C) and 113°F (45°C) at a relative humidity of 10%-90% (non-condensing).

Meeting Electrical Requirements

Load Limitations

Each FR6802+ frame can contain two redundant, modular, self-contained power supply units with standard IEC mains connectors. One PSU can support an entire frame load. An AC unit requires an independent supply of 100 to 250 V AC, at 47 to 63 Hz. DC units require an independent supply of 36 to 72 V DC.

Voltage Selection

FR6802+ frames do not have voltage selector switches. Voltage selection is automatic upon power-up.

Maximum Power Dissipation

These ratings refer to the total module power consumption (excluding that of the power supply) allowable within an FR6802+ frame. The limits are based on the ability of the unit to dissipate heat over a temperature range of 32° to 113°F (0° to 45°C).

The maximum frame loading figures are described in [Table 2-3](#).

Table 2-3. Dissipation Specifications

Power Supply	Maximum Dissipation (per Module)	Maximum Dissipation (per Frame)
AC power supply	<ul style="list-style-type: none"> • Double-slot module: 12 W • Single-slot module: 6 W 	120 W
DC power supply	<ul style="list-style-type: none"> • Double-slot module: 10.5 W • Single-slot module: 5.25 W 	105 W

Installing the Frame in a Rack

Ensuring Adequate Rack Space

The FR6802+ frame is designed to mount into a standard-width 19-in. (483-mm) rack and occupies a vertical space of 2RU.

Frames are secured to the rack with standard front-mounting ears built into the chassis. Ensure you have provided adequate space behind the mounting ears, and appropriate clearance for the connecting cables at the rear of the frame.

Attaching Optional Rear-Support Brackets

Although front-mounting ears are provided, Leitch recommends using rear-support brackets to support the installed frame, its cabling, and other stacked frames.

Follow this procedure to identify rear-support brackets and attach them to the frame:

1. Locate two tongue-shaped frame-support brackets, two slotted rack-support brackets, and one cable support bar from the packing box (if ordered). See [Figure 2-1](#).

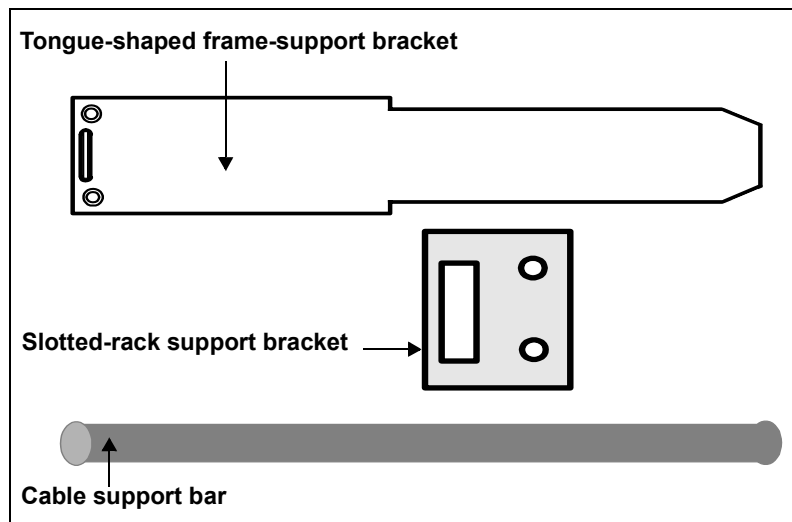

Figure 2-1. Support Brackets and Cable Support Bar

2. Thread the cable support bar into each rear-support bracket, and then secure with the provided screws. See [Figure 2-2](#).

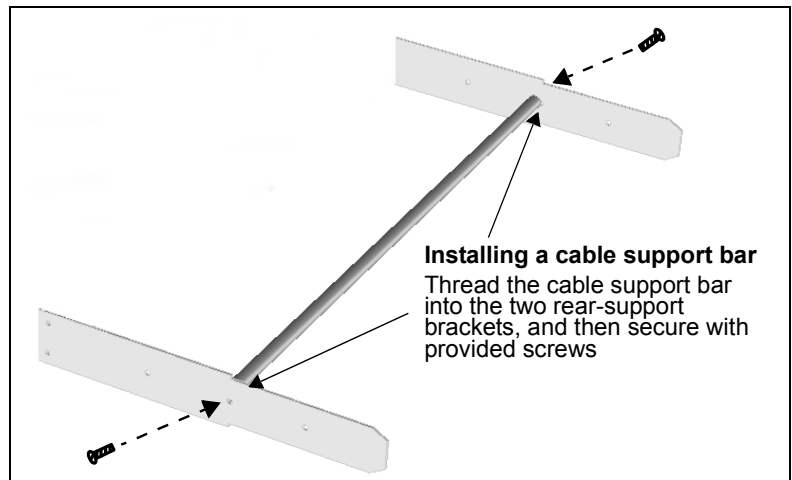

Figure 2-2. Installing a Cable Support Bar



Caution

Do not use screws longer than those provided for the rear support brackets. Four 4-40 x 1/4-inch flat-head screws are provided for this purpose. Longer screws could cause internal damage.

3. Attach the two tongue-shaped frame-support brackets to the sides of the FR6802+ frame, using the provided screws. See [Figure 2-3](#).

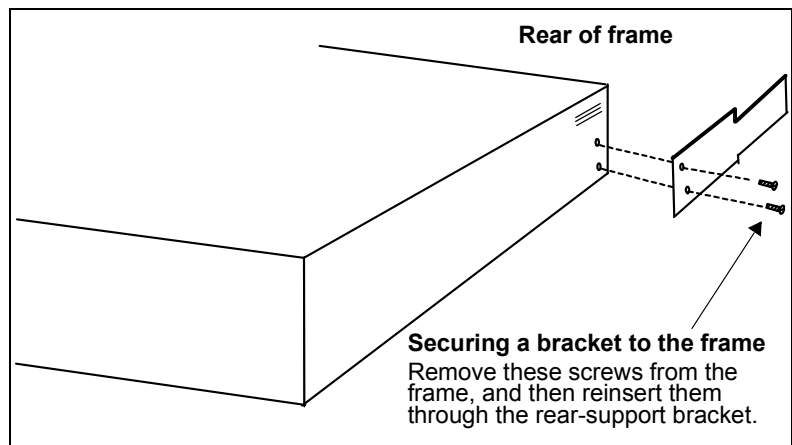

Figure 2-3. Installing a Rear-Support Bracket

4. Attach the two slotted rack-support brackets at the rear of the rack, with the slots facing inward. See [Figure 2-4](#).

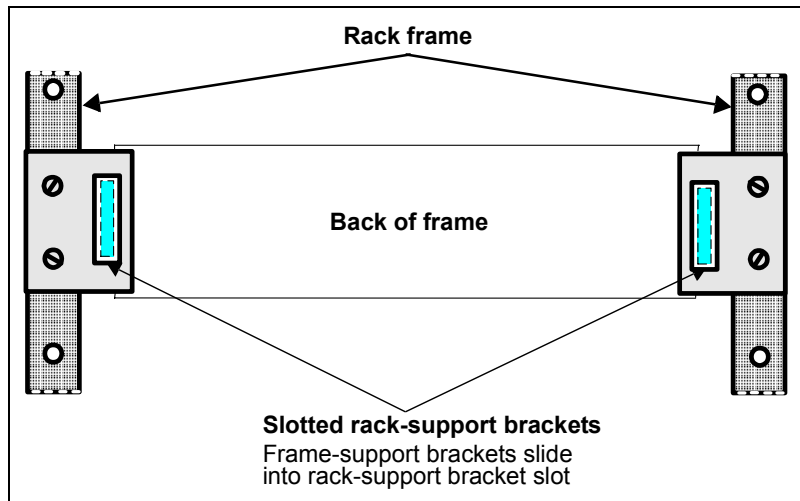

Figure 2-4. Installing Rack-Support Brackets

5. Position the FR6802+ into the rack, ensuring that the frame-support brackets slide into the installed slotted rack-supports.
6. Attach the front-mounting ears on the chassis to the rack, using the appropriate rack screws.

Installing 6800+ Modules



Caution

Before installing your modules, see [“Maximum 6800+ Frame Power Ratings”](#) on page 14.

There are different module and connector types that may require installation:

- Double-slot back connectors
- Single-slot back connectors
- Front modules

Depending on the product type, there are various back connectors, front modules, and frame types that are available, interchangeable, and compatible. For example, module back connectors can come in either a double-slot or single-slot sizes; 6800+ front modules may connect to either single- or double-slot back connectors; and certain 6800+ modules and back connectors can be installed in either an FR6802+ or 6800/7000 series frame. Check the individual module manual that comes with your product to identify which back connector types work with your module, and which frames are compatible with the module.

Up to twenty front modules connected to single-slot back connectors fit in an FR6802+ frame. Up to ten front modules can fit in an FR6802+ if they are connected to double-slot back connectors (two spaces are required to accommodate the extra width of the back connector). Compatible 6800/7000 series modules can only connect to double-slot back connectors.

You can install most 6800+ modules in any unused slot without interfering with other frame functions.

Installing 6800+ Modules in an FR6802+ Series Frame

Follow these steps to install modules into an FR6802+ frame. All modules are hot-swappable and can be installed with the power supply either turned on or turned off.

1. Remove a blank back connector from the frame. See [Figure 2-5](#).

Do not discard the blank back connectors. They may be needed for future configurations.

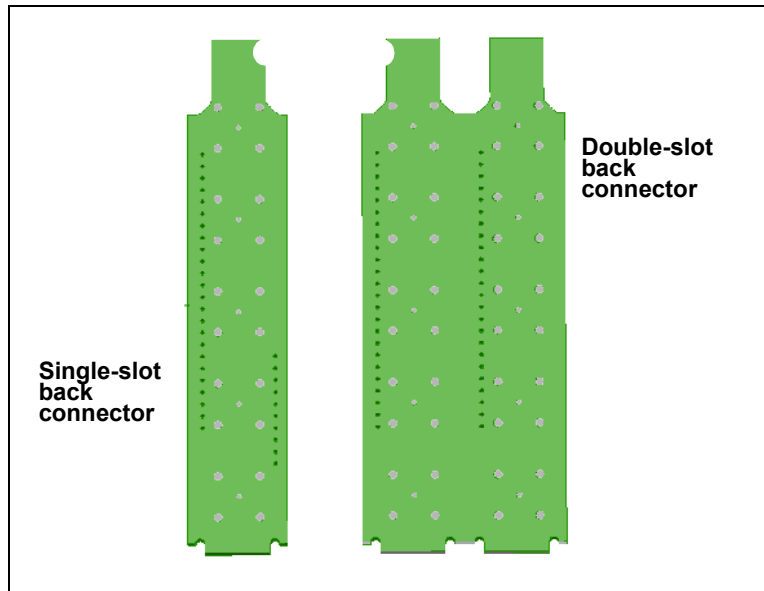

Figure 2-5. Blank Back Connectors



Note

The module lip must be inserted fully and securely into the bottom frame slot to ensure proper module operation

2. Install the new back connector by inserting the bottom lip into the required frame slot and then screwing it into place. See [Figure 2-6 on page 23](#).

Ensure that the EMI gaskets on the right side of the back connector remain in place during the installation. (The gaskets fit tightly.)

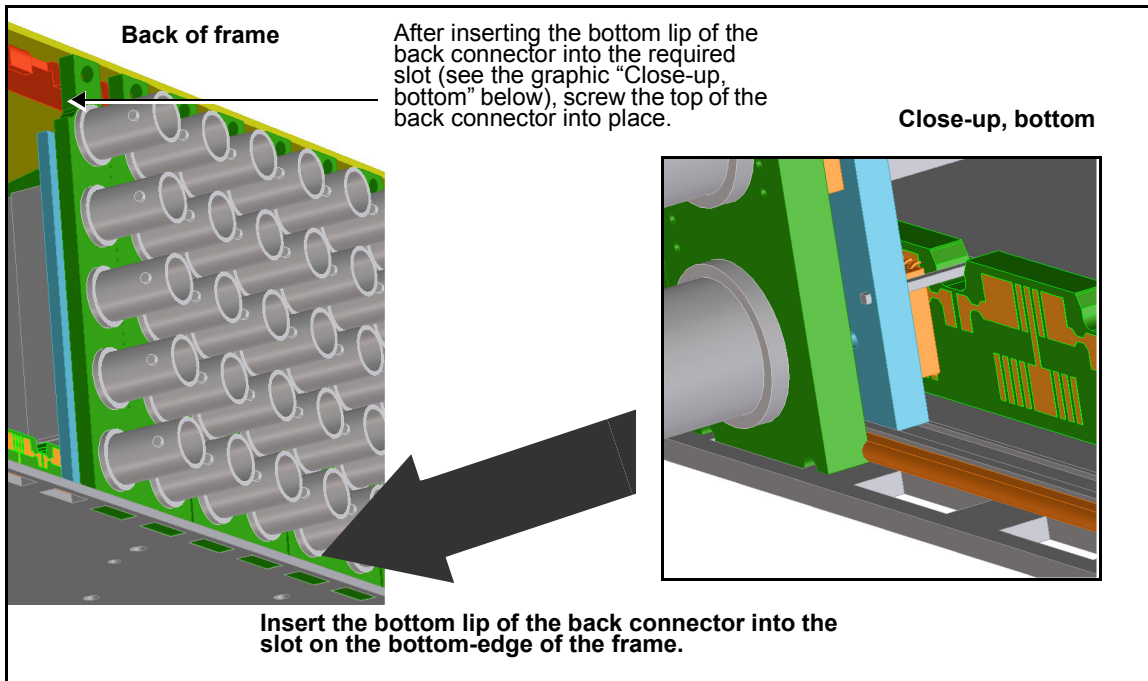

Figure 2-6. Installation of Back Connectors, Rear View



Caution

The front module must match the corresponding back connector; otherwise, the modules will not operate correctly. Some module insertions may be prevented if the modules are incompatible.

3. Apply the back connector labels to the back connecting module if these are supplied separately.
4. Pull out the finger-release screws on the right and left side of the front panel, and then open it.
5. Locate the front module slot that corresponds with the matching back connector.
6. Slide the module into the guides on the frame floor. See [Figure 2-7 on page 24](#).

The module is properly seated when its edge is flush with the guide edge and the extractor handle closes. See [Figure 2-8 on page 24](#).

Caution

To prevent overheating during general frame operation and to maintain proper airflow, keep the front panel closed and all back connector slots covered during operation.

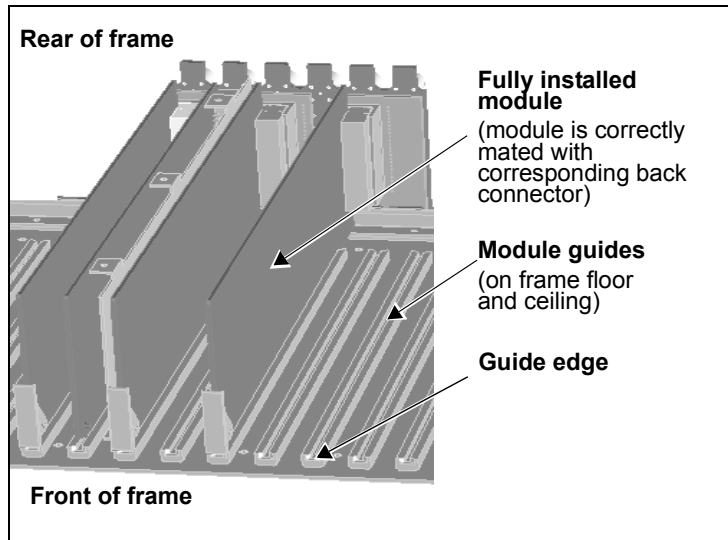

Figure 2-7. Frame Module Guides, Disassembled View

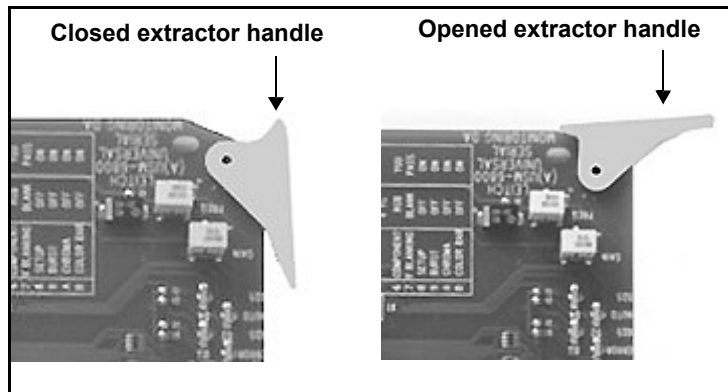

Figure 2-8. Extractor Handle in Closed and Opened Positions

7. Install the remaining modules and back connectors, and then make all of the necessary system connections.
8. Close the front panel to ensure proper frame ventilation.

Installing 6800+ Modules into a 6800/7000 Series Frame



Note

The 6800/7000 series frames have a back panel already in place. There is no need to install an individual back connector into this type of frame.



Caution

To prevent overheating during general frame operation and maintain proper airflow, keep the front panel closed and all back connector slots covered during operation.

Do not mix and match modules and back connectors. The front module must mate with the corresponding back connector.

If your 6800+ module can be installed in a 6800/7000 series frame, follow these installation steps. Check the individual module manual that comes with your product to identify which frames are compatible with your module.

All modules are hot-swappable and can be installed with the power supply either turned on or turned off.

1. Pull out the finger-release screws on the right and left side of the front panel, and then open it.
2. Locate the front module slot that corresponds with the matching back connector, and then slide the module into the guides.

See [Figure 2-9](#) for a 1RU horizontal installation illustration and [Figure 2-10](#) for a 2RU vertical installation illustration.



Figure 2-9. 1RU Installation of a Module

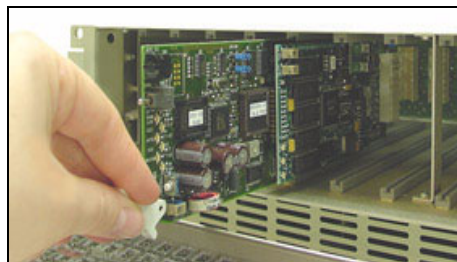

Figure 2-10. 2RU Installation of a Module

The module is properly seated when its edge is flush with the guide edge and the extractor handle closes. See [Figure 2-8 on page 24](#).

3. Close the front panel to ensure proper frame ventilation.

Making Connections

Once you have installed your FR6802+ modules, you can connect them to the appropriate input and outputs.

Removing 6800+ Modules



Note

Modules are hot-swappable and can be removed or replaced without powering down the frame.

To remove a module from an FR6802+ or 6800/7000 series frame, follow these steps:

1. Pull out the finger-release screws on the right and left side of the front panel, and then open it.
2. Grasp the extractor handle on the installed module, and then pull the module out of its slot using the handle as a lever.
3. Close the front panel to ensure proper frame ventilation.
4. Remove the back connector from an FR6802+ series frame in this way:
 - a. Unscrew the top of the corresponding back connector, and tip it towards you.
 - b. Pull the bottom lip of the back connector from its slot.
 - c. Reinstall a new or blank back connector in the empty slot to ensure proper frame ventilation.
5. If you are removing a module from a 6800/7000 series frame, first remove the back connector overlay from the back panel. Then, replace with a new back connector overlay, if required.



Caution

To prevent overheating during general frame operation and maintain proper airflow, keep the front panel closed and all back connector slots covered during operation.

Installing Fans



Caution

See the Caution about potential frame and module overheating on [page 16](#) before installing the 6800+ modules in your frame.

In most instances, a four-fan assembly is pre-ordered and factory-installed in the FR6802+ frame before it is shipped. However, you will need to do the installation yourself in the following cases:

- If you order an FR6802+FA Fan Assembly separately from the FR6802+ frame (thereby upgrading your frame from an FR6802+ to an FR6802+F)
- If you replace one of the four fan units in the assembly

Upgrading to an FR6800+F Frame

If your FR6802+ frame currently does not have a fan assembly and you wish to upgrade your frame to an FR6802+F model, you must remove the existing front panel, install an FR6802+FA Fan Assembly, and then make minor changes to jumper settings.

Procedure

Follow this procedure to install a fan assembly on an FR6802+ frame:

1. Remove all power from the FR6802+ frame, and then remove the mounted frame from the rack.
2. Take off the existing FR6802+ front panel by removing the two screws located at the back of each mounting ear.

Retain the screws for use with the upgraded front panel (step 3).

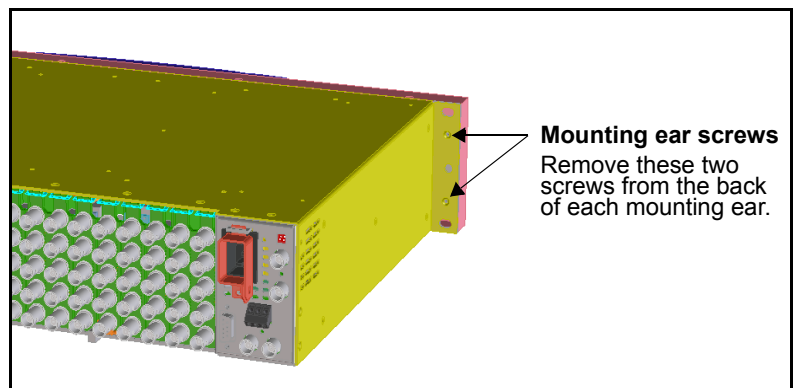

Figure 2-11. Removing Front Panel Mounting Ear Screws

3. Install the upgraded FR6802+**F** front panel by securing it to the mounting ears with the four screws that were removed in the previous step.
4. Locate and remove the resource card on the left side of the frame. See [“Replacing a Resource Card” on page 56](#).
5. Locate jumper **CJ4** near the center of the resource card, and then set it to FANS by placing a jumper on pins 1 and 2.

[Figure 2-12](#) shows the available jumper settings.



Note

The white triangle near the jumper pins on the resource card indicates pin 1.

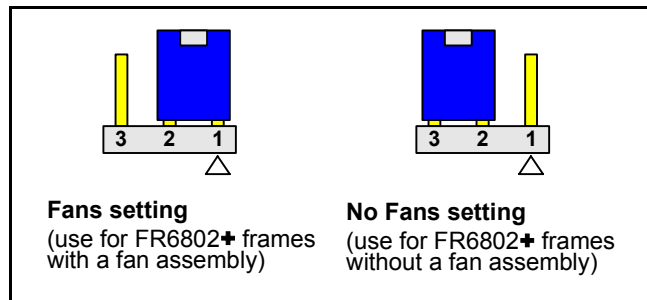

Figure 2-12. CJ4 Jumper Settings on Resource Card

6. Return the resource card to its slot in the frame, and then close the front panel.
7. Install the upgraded frame in the rack and then reapply power.

Replacing a Failed Fan Unit

In the event that one of the fan units fails in the FR6802+FA Fan Assembly panel, you should install a replacement as soon as possible to prevent overheating. Replacement fans are available from Leitch.

Procedure

To replace a failed fan unit from the front panel, follow these steps:

1. Remove all power from the FR6802+ frame.
2. Pull out the finger-release screws on the right and left side of the front panel, and then open it.
3. Remove the screws on the top and bottom edges of the front panel that hold the fan assembly cover in place (see [Figure 2-13](#)).

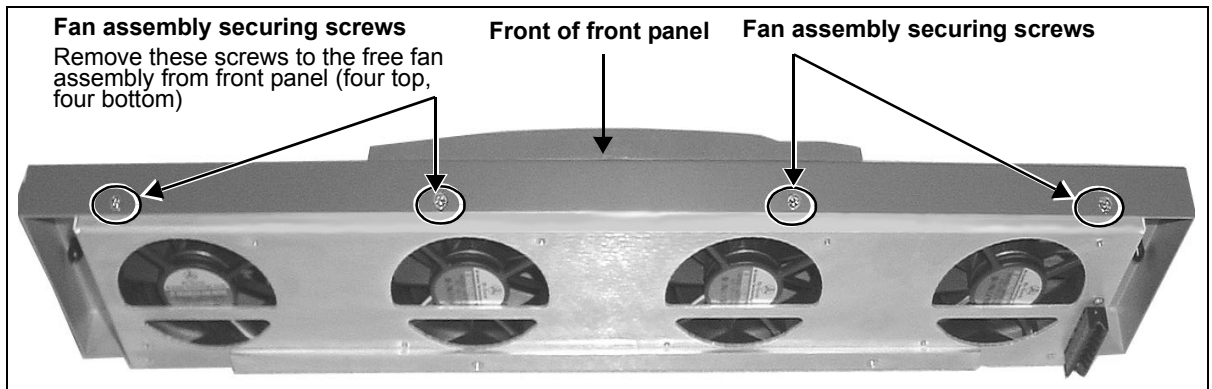

Figure 2-13. Removing the Fan Assembly from the Front Panel

4. Remove the fan assembly from the front panel.

5. Identify the fan you are replacing, and then remove the corresponding header wires from the PCB board along the top of the assembly (see [Figure 2-14](#)).

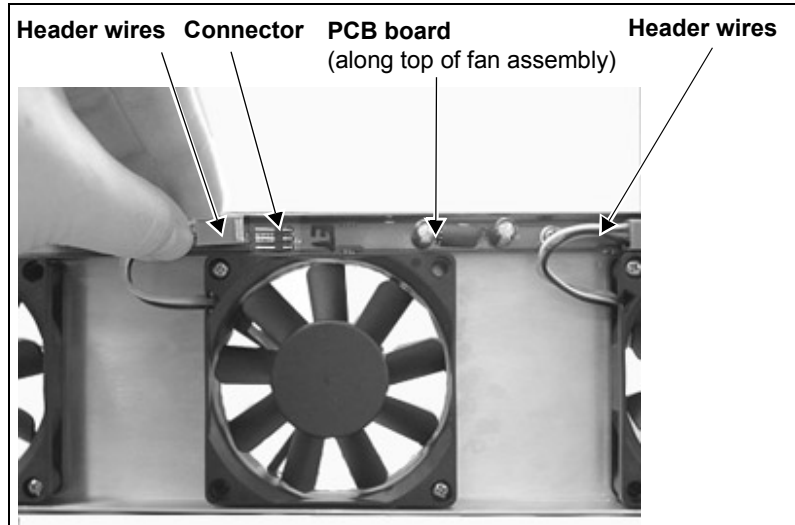

Figure 2-14. Removing Header Wires from Fan Assembly PCB Board

6. Unscrew the fan, and then pull it firmly away from the assembly to remove it from the standoffs (see [Figure 2-15](#)).

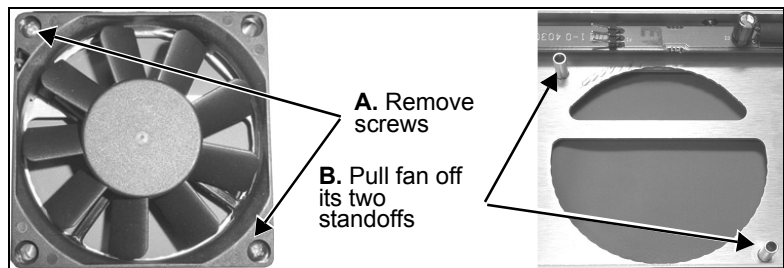

Figure 2-15. Removing a Fan from the Assembly

7. Position a new fan over the assembly standoff, and then fasten the fan into place with the supplied screws (see [Figure 2-13 on page 29](#)).
(Ensure that the fan labelling is face down, and that the header wiring is at the top left corner of the installed fan, as shown in [Figure 2-14 on page 30](#).)
8. Connect each new fan's header wires to the assembly PCB board (see [Figure 2-14 on page 30](#)).
9. Replace the fan assembly inside the front cover, and then secure the assembly into place with the provided screws.
Ensure that the following items are aligned:
 - The LEDs on the fan assembly PCB with the corresponding holes on the front panel
 - The fan assembly screw holes with the holes on the front panel
10. Close the front panel, and then reapply power to the frame.

Making System Connections

Connecting to a Power Source



Note

Ensure that a different electrical source is used for each power supply. This ensures true power system redundancy.

Depending on the power supply you are connecting to, choose one of the options below:

- **AC:** A supply of 90 to 240 V AC, 47 to 63 Hz is required for both PSUs. Connect one end of the power cable to an IEC power connector at the back of the FR6802+ frame. Plug the other cable end into a grounded electrical source. (Repeat this procedure for the redundant power supply using an independent power source.)
- **DC:** A supply of -36 to -72V DC is required for each DC power supply.

Figure 2-16 and Table 2-4 define the pin connections for the XLR connector at the back of the DC power supply or frame.

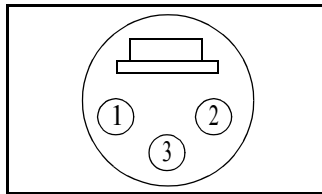

Figure 2-16. XLR Connector

Table 2-4. Pin Connection Labels for the DC XLR Connector

Pin Number	Connection
1	-48 V
2	0 V
3	chassis

For DC power supplies, connect one end of the power cable to an XLR power connector at the back of the FR6802+ frame. Plug the other cable end into a grounded electrical source. (Repeat this procedure for the redundant power supply using an independent power source.)

A **Power** switch is located on the front face of each power supply. Before operating the frame, ensure that both PSUs are turned on to ensure full redundancy.

Making Genlock Connections for Signal Synchronization

The genlock connectors on the FR6802+ frame provide an input path for the genlock signal, and have a loop-through capability.

To make genlock connections for signal synchronization, connect the reference signal to one of the Genlock loop-through BNC connectors on the FR6802+ frame. The other connector can be used to route the reference signal to other locations. Terminate the reference signal at its final routed location.

Creating a Serial Communication Network

By creating a serial connection between an FR6802+ frame and a PC running the free +Pilot Lite control software, you can monitor and control every frame and its installed devices from the PC.

Procedure

To create a 6800+ communication control network, follow this procedure:

1. Connect one FR6802+ frame to another by using a customer-supplied BNC coaxial cable.

To do this, connect each end of a BNC cable to the **Communication loop through** of each frame's rear panel. These BNCs have input and output functions.

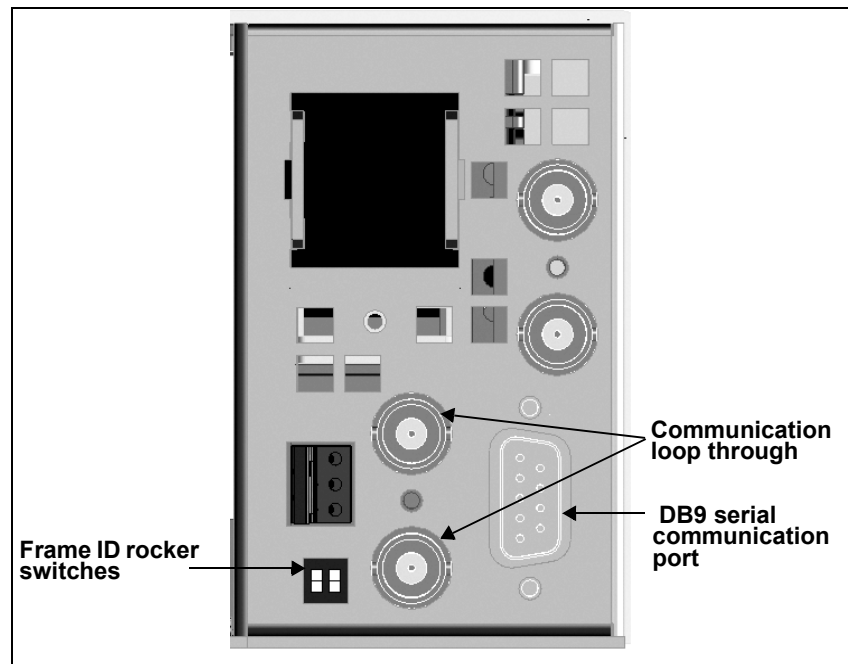

Figure 2-17. Rear Panel Connections for FR6802+ Frames

2. Repeat this coaxial cable connection between other FR6802+ frames until all frames (up to a maximum of four) are connected to each other.

3. Identify each frame on the network by setting a unique switch combination for every frame.

The **Frame ID** rocker switches on the back of each FR6802+ frame can be set to one of four combinations. Choose a different combination (a unique identifier) for each frame on the control network. (Push down for the “On” position.) See [Table 2-5](#) below.

Table 2-5. Identifying FR6802+ Frames on the Control Network

FR6802+ Frame	Frame ID Switch 0	Frame ID Switch 1
1	Off	Off
2	On	Off
3	Off	On
4	On	On

4. Connect a customer supplied RS-232 null modem cable between the DB-9 serial communication port of one of the connected frames and a PC with the accompanying +Pilot Lite software application installed on it.

See your accompanying *+Pilot Lite User Manual* or *Online Help* for more information on using this software application to control and monitor your 6800+ serial communication network.

To start the +Pilot Lite control software application, follow these steps:

1. Click the **Start** button, and then select **Programs**.
2. Select **Leitch + Pilot Lite 1.0** folder, and then select **+ Pilot Lite**.

The main application window opens.

If this is the first time the application has been launched since installation, the **Control** window displays a “No device selected” message. Otherwise, the application will attempt to control the device selected before the application was last closed.

See your *+Pilot Lite User Manual* or *Online Help* for more information on using this control software.

Connecting the GPI Alarm Relay to a Monitoring System

To send alarm signals from the FR6802+ frame to a control monitoring system, follow these steps:

1. Connect one end of a 3-conductor, 18 to 25 gauge cable to the GPI connector at the back of the FR6802+ frame.
2. Connect the other end of the cable to a customer supplied monitoring panel.

Figure 2-18 shows the GPI alarm relay connector (with a terminal block connector plug), and describes the pinouts.

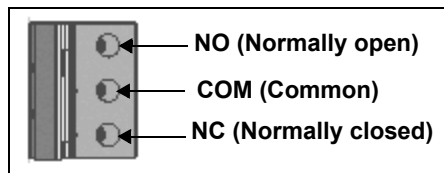

Figure 2-18. GPI Alarm Connector

See “[Understanding Status LEDs](#)” on page 38 for more information on FR6802+ alarms.

Connecting to a CCS Network



Note

FR6802+XF frames cannot be connected to a serial network and an Ethernet network simultaneously.

To communicate with an FR6802+ frame using CCS network, you must install an ICE6800+ module on a host FR6802+XF frame. Using CCS software applications such as Pilot and Navigator, you can configure, monitor, and control up to nine FR6802+ frames and their modules for each host FR6802+XF frame.

Due to the need for a separate back module, ICE6800+ modules cannot be installed on FR6802+DM or FR6802+DMF frames. FR6802+X frames require an optional FR6802+FA Fan Assembly panel to operate an ICE6800+ module.

See the *ICE6800+ Interface Card to Ethernet Installation and Operation Manual* for more information on the installation and operation of this module.

Operating the Frame

Reviewing the Steps

1. Install the FR6802+ frame with its modules in a rack (see [page 18](#)), and then make the required system connections (see [page 32](#)).
2. Connect the power cable(s) between the IEC power connector(s) and a grounded electrical source.
3. Turn on each PSU by pushing its **Power** switch, located on the front of each power supply.
4. Establish a serial or CCS communication network, by following either the serial or CCS steps below:

SERIAL

- a. Make the appropriate input/output connections.
- b. Set the **Frame ID** switches on each frame for network identification purposes.
- c. Using an RS-232 serial cable, connect the FR6802+ frame to a local PC or laptop that has the +Pilot Lite control software application installed on it (see [page 35](#)).

CCS

- a. If you have an ICE6800+ Interface Card to Ethernet module, connect one end of a Category 5 (CAT-5) Ethernet cable to your network hub or switch.
 - b. Connect the other end of the cable to the RJ-45 Ethernet port on the ICE6800+ module. (see [page 36](#)).
5. Make the appropriate GPI alarm relay connections (see [page 36](#)) if you want to monitor the frame alarm status remotely.



Note

You cannot be connected to both the 6800+ serial communication network and the Ethernet network simultaneously.

Understanding Status LEDs

Table 2-6 describes the three LEDs located on the front panel of the FR6802+ frame:

Table 2-6. LED Descriptions

LED	Color	Meaning (When Lit)
Alarm	Red	One of the following events has occurred in the frame: <ul style="list-style-type: none">• Power supply failure• Module detection failure• Resource module failure
Fan Failure	Red	The fan assembly is not operating normally.
Power	Green	There is power in the frame; the frame and power supply are operating within normal operating conditions.

Understanding Card-Edge Controls

Introducing Control Types



Note

Leitch recommends that you use the available 6800+ software control options (serial/local or Ethernet/remote) to aid in viewing, setting, and confirming parameter values.

You can operate and monitor settings for the FR6802+ using the two control switches and the LED indicators on the card-edge of the module. As with all 6800+ products, external local or remote monitoring equipment (a PC or control panel) is required.

Two card-edge switches work together to provide access to all of the parameter banks and control options on the module: the mode select rotary switch and the navigation toggle switch. [Figure 2-19](#) illustrates the location of these switches.

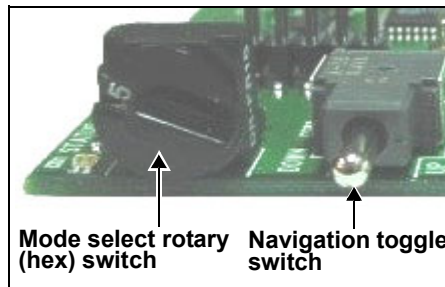

Figure 2-19. Card-Edge Controls

Mode Select Rotary Switch



Note

Position “0” permits the navigation toggle switch to select a bank.

The mode select rotary switch (hex switch) selects the parameter type. Rotate the switch until you see the number (1 to 9) or letter (A to F) that corresponds with the desired parameter. To view hex switch positions and corresponding banks and controls, see the table entitled “Card-Edge Parameter Options” in the individual product manual that accompanies your module.

Navigation Toggle Switch



Note

Some 6800+ modules can be used in both horizontal and vertical configurations. Ensure that you follow the **Up** and **Down** markings on the module to increase or decrease parameter values, respectively.

The navigation toggle switch selects a bank (when the hex switch is set to “0”) and individual parameter values. Follow the markings on the module board (**Up** and **Down**) to set a parameter value.

- Toggle the switch **Up** through the list of banks or to increase the parameter value.
- Toggle the switch **Down** through the list of banks or to decrease the parameter value.

See the section “Changing Parameter Settings” in the individual product manual that accompanies your module for more information.

Introducing Parameter Types

Most FR6802+ parameters are adjustable and can be set using either card-edge controls (see “[Introducing Control Types](#)” on page 39) or a software control application. However, some parameters are considered “read-only” and cannot be changed. These parameters (indicated by the abbreviation “[RO]”) provide status and feedback information only.

Parameter lists may wrap or clip. If the list is set to wrap, it returns to the beginning of its range or options after you have toggled through all of them. Clipping requires you to scroll back through the options to return to the beginning of the list.

Wrapping is only available from the card edge. Parameters that normally wrap when adjusted via the card edge will clip when adjusted using a control software application.

Adjustable Parameters



Note

See the table titled “Card-Edge Parameter Options” in the individual product manual that accompanies your module to view the various numerical and selectable parameters for the FR6802+.

Two types of adjustable parameters can be changed using the card-edge controls:

- *Numerical* parameters, which require you to select a value within a numerical range (for example, between 0 and 524)
- *Selectable* parameters, which require you to select a specific option (for example, 525 or 625)

Both numerical and selectable parameter changes are immediate.

Use the available 6800+ software controls (serial/local or Ethernet/remote network) to view and monitor parameter selections.

Read-Only Parameters

Many of the read-only parameters have related LEDs on the front of the module’s card edge. See the section “Monitoring LEDs” in the individual product manual that accompanies your module for information on the location of these LEDs.

Operating Installed Modules

All 6800+ modules can be operated and monitored using card-edge controls, a local PC/laptop via a serial connection, or a remote PC via an Ethernet connection. Certain 6800/7000 series modules that may be housed in an FR6802+ frame offer the same local operation choices, although they cannot be monitored remotely.

Each module has a different set of operating parameters and controls. See the individual product manual that accompanies your module for operating details.

Operating Notes

When setting the control parameters on an FR6802+ frame, observe the following:

- If you make changes to certain parameters, other related parameters may also be affected. See the section “Cross-Functional Parameter Changes” in the individual product manual that accompanies your module for more information.
- When you change a parameter, the effect is immediate. However, the module requires up to 20 seconds to save the latest change. After 20 seconds, the new settings are saved and will be restored if the module loses power and must be restarted.

6802+PS and 6802+PS48 Power Supplies

Overview

Each FR6802+ frame is equipped with one self-contained 6802+PS power supply unit that can support an entire frame load. An optional redundant PSU can be ordered separately. If the frame has two PSUs installed, the load is shared equally during normal operation.

This chapter describes the following topics:

- [“Installing a Power Supply” on page 44](#)
- [“Protecting the Power Supply” on page 45](#)
- [“Understanding Alarm Signals and Indicators” on page 46](#)

See [“Chapter 4: Specifications”](#) for PSU specifications.

For information on maximum frame capacity based on AC or DC power supply usage, see [“Maximum 6800+ Frame Power Ratings” on page 14](#).

See your [+Pilot User Manual](#) or [CoPilot User Manual](#) for information on remotely setting and monitoring power supply options.

Installing a Power Supply

This section describes the following procedures:

- Disconnecting and removing an existing power supply
- Installing a new power supply

Disconnecting and Removing an Existing Power Supply

 **Note**

A redundant FR6802+ power supply is hot-swappable and can be replaced without removing power from the remaining power supply.

1. Toggle the **Power** switch to the “Off” position (toggle right) on the front of the power supply that you wish to remove.
2. Unplug the power supply from its grounded electrical source.
3. Remove the rear panel screw that secures the power supply to the frame chassis. See [Figure 3-1](#).



Figure 3-1. Removing the Rear Panel PSU Screw

4. Pull out the finger-release screws on the right and left sides of the front panel, and then open it.
5. Grasp the handle on the front of the power supply, and then pull it out of the frame. See [Figure 3-2 on page 45](#).

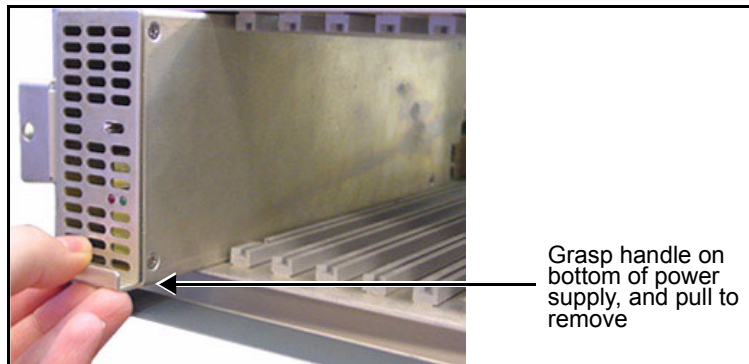

Figure 3-2. Removing a Power Supply

Installing a New Power Supply

1. Pull out the finger-release screws on the right and left sides of the front panel, and then open it.
2. Slide the new power supply into position in the frame, and then close the front panel.
3. Secure the power supply to the frame with the provided 4-40 rear panel screw. See [Figure 3-1 on page 44](#) for the screw location.
4. Connect the new power supply to a grounded electrical source, and toggle the **Power** switch to the “On” position (toggle left) at the front of the supply.

Protecting the Power Supply

The 6802+PS PSU is designed to shut down in over-voltage and over-temperature situations. In both instances, the power supply automatically returns to normal operation when the conditions that triggered the shutdown are resolved.

The over-voltage protection (OVP) level is set at 120% \pm 10% of the nominal output voltage (13.6 output only). In the case of an OVP condition, the power supply shuts down until the condition is resolved.

If the PSU falls outside of the normal operating temperature range of 32°F (0°C) to 113°F (45°C), it will shut down until the temperature returns to the normal range.

Understanding Alarm Signals and Indicators

If the PSU detects an over-voltage, over-current, or over-temperature condition, it sends a fault signal to a monitoring device (such as a locally connected PC or a GUI-based software application like Pilot).

On the FR6802+ front panel, the PSU status is communicated via two LED indicators (see [Figure 3-3](#)).

 **Note**

A third LED (right) is present on the front panel, but reports only the fan assembly status.

- A green **Power** LED (right) indicates that the power supply is operating normally with no reported fault conditions.
- A red **Alarm** LED (middle) indicates that a fault condition exists.

Both LEDs are located on the front panel of the FR6802+ frame.

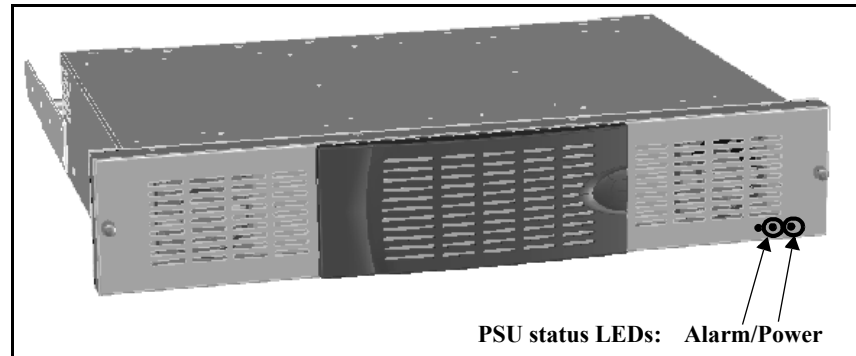

Figure 3-3. Location of PSU Status LEDs

The **Alarm** LED automatically turns off once the condition that triggered it is resolved.

Specifications

Overview

This chapter describes the following items:

- “[Frame Specifications](#)” on page 48
- “[Power Supply Specifications](#)” on page 48

Specifications and designs are subject to change without notice.

Frame Specifications

Table 4-1. Frame Specifications

Item	Specification
Size	3.5 x 19 x 11.5 in. (8.8 x 48.3 x 29.2 cm)
Weight	9 lb (4.08 kg), empty 12 lbs (5.44 kg), with two power supplies

Power Supply Specifications

6802+PS

Table 4-2. 6802+PS AC Power Supply

Item	Specification
Size	1.45 x 11.25 x 3.35 in. (3.68 x 28.58 x 8.51 cm)
Weight	1.5 lbs (0.68 kg)
Load step response	Recovery to 1% of nominal within 1 msec
Minimum load	No load
Ripple and noise	<3% of nominal voltage
Over-voltage protection	120% \pm 10% of nominal output voltage (13.6 V output only)
Temperature range	32°F (0°C) to 113°F (45°C)
Input Specifications	
Input voltage	100 to 250 V AC (\pm 10%)
Frequency	47 to 63 Hz
Input current	<ul style="list-style-type: none"> • 2 A rms maximum at 90 V AC, 120 W output power • 0.75 A rms maximum at 274 V AC, 120 W output power

Table 4-2. 6802+PS AC Power Supply (Continued)

Item	Specification
Inrush current (maximum peak)	25 A
Efficiency	>75% at 117 V AC, 120 W output (typical)
Power factor	<ul style="list-style-type: none"> • >0.90 at 130 W output power • 100 to 250 V AC input voltage
Output Specifications	
Output voltages	<ul style="list-style-type: none"> • V Out to V Out_RET: +13.6 V ($\pm 3\%$) • V Out to DGND: +6.8 V ($\pm 3\%$) • V Out_RET to DGND: -6.8 V ($\pm 3\%$)
Output current (maximum load)	<ul style="list-style-type: none"> • +6.8 V to -6.8 V (9.6 A) • +6.8 V to DGND (15.0 A) • -6.8 V to DGND (10.0 A)
Output power limit	<ul style="list-style-type: none"> • +6.8 V to -6.8 V: 160 W $\pm 15\%$ • +6.8 V to DGND (17.0 A): 120 W $\pm 10\%$ • -6.8 V to DGND (12.5 A): 85 W $\pm 10\%$
Output power	130 W, combined maximum
Start-up time	All outputs are above lower limit within one second of application of input power
Hold-up time	>16 msec at 130 W output power at any input voltage within the specified range
Ramp-up time	<ul style="list-style-type: none"> • All outputs are above lower limit within 100 msec of initiated ramp-up time • Voltage rise on all outputs is monotonic with <5% overshoot
EMC	Compliant with FCC part 15 Class A, EN 55103-1 and EN 55103-2
Safety	Meets UL 60950, CAN/CSA 22.2 No. 60950 and EN 60950

6802+PS48

Table 4-3. 6802+PS48 DC Power Supply

Item	Specification
Size	1.45 x 11.25 x 3.35 in. (3.68 x 28.58 x 8.51 cm)
Weight	1.5 lbs (0.68 kg)
Ripple	<1% pk-to-pk on all outputs
Operating temperature range	32°F (0°C) to 113°F (45°C) at full rated output
Inputs	-36 to -72 VDC
Outputs	<ul style="list-style-type: none"> • +6.3 V @ 10 A maximum • -6.4 V @ 7 A maximum
Initial setting	<ul style="list-style-type: none"> • +6.8 V @ 5 A (adjustable) • -6.8 V @ 4 A (not adjustable but typical)
Output power (with forced air cooling)	<ul style="list-style-type: none"> • 65 W maximum for +6.5 V output • 45 W maximum for -6.5 V output
Output power (without forced air cooling))	<ul style="list-style-type: none"> • 45 W maximum for +6.5 V output • 35 W maximum for -6.5 V output
Maximum total power	<ul style="list-style-type: none"> • 105 W with forced air cooling • 50 W without fans
Load regulation	The power supply is soft-regulated to support redundant operation with power sharing

Table 4-3. 6802+PS48 DC Power Supply (Continued)

Item	Specification
Line regulation	>1% over full input range
Transient response	<1.2 msec for recovery to within 2% for a step current change of 50-100% of rated
Protection	<ul style="list-style-type: none"> • Inrush current limiting • Input transient protection • Short circuit protection on all outputs • Reverse input voltage protection • Input fuse
EMC	Compliant with FCC part 15 Class A, EN 55103-1 and EN 55103-2
Safety	Meets UL 60950, CAN/CSA 22.2 No. 60950 and EN 60950

Servicing Instructions

Overview

Attempts to make repairs to frame components—other than the procedures described in this chapter—will result in the voiding of the product’s warranty.

Servicing instructions for the FR6802+ are limited to replacing a resource card.

PROCEDURE

THESE SERVICING INSTRUCTIONS ARE FOR USE BY QUALIFIED SERVICE PERSONNEL ONLY. TO REDUCE THE RISK OF ELECTRIC SHOCK DO NOT PERFORM ANY SERVICING, OTHER THAN THAT CONTAINED IN THE OPERATING INSTRUCTIONS, UNLESS YOU ARE QUALIFIED TO DO SO.

The following topics are described in this chapter:

- “Battery Use Caution” on page 54
- “Fuse Replacement Caution” on page 55
- “Replacing a Resource Card” on page 56

Battery Use Caution



CAUTION: DANGER OF EXPLOSION IF BATTERY IS INCORRECTLY PLACED. REPLACE ONLY WITH THE SAME OR EQUIVALENT TYPE RECOMMENDED BY THE MANUFACTURER. DISCARD USED BATTERIES ACCORDING TO THE MANUFACTURER'S INSTRUCTIONS.

Finland

VAROITUS: Paristo voi rajahtaa, jos se on virheellisesti asennettu. Vaihda paristo ainoastaan valmistajan suosittelemaan tyyppun. Havita kaytetty paristo valmistajan ohjeiden mukaisesti.

Sweden

VARNING: Explosionsfara vid felaktigt batteribyte. Anvand samma batterityp eller en eller en ekvivalent typ som rekommenderas av tillverkaren. Kassera anvant batteri enligt fabrikantens instruktion.

Denmark

Advarsel! Lithiumbatteri. Eksplosionsfare ved fejlagtig handling. Udskiftning ma kun ske med batteri af samme fabrikat og type. Lever det brugte batteri tilbage till leverandoren.

Korea

경고

만약 틀린 전지로 교환했을 경우, 폭발 위험이 가능합니다. 똑같거나, 동등한 종류와 교체하는 것을 제조업자로서 권장합니다. 제조업자의 지시에 따라, 사용된 전지는 버려 주십시오.

Fuse Replacement Caution



CAUTION: FOR CONTINUED PROTECTION AGAINST RISK OF FIRE, REPLACE ONLY WITH THE SAME TYPE OF FUSE.

French

ATTENTION: REMPLACER UNIQUEMENT PAR UN FUSIBLE DE MEME TYPE.

Table A-1. Fuses and Markings

List of Fuses	Marking
F1 (6802+ AC power supply)	T 3.15 A H 250 V
F1 (6802+PS48 DC power supply)	F 5A 250 V
F1, F2 (back connectors)	T 2A 63 V or 3A 15 V (resettable fuses)

Replacing a Resource Card

If a failure occurs, your customer service representative may recommend that you upgrade or replace the resource card that comes with your FR6802+ frame.

Removing an Existing Resource Card

To remove an existing resource card, follow these steps:

1. Pull out the finger-release screws on the right and left sides of the front panel, and then open it.
2. Locate the resource card on the left side of the frame, beside the power supply.
3. Insert a screwdriver into the card-removal hole on the resource card, and then pull the resource card out of its slot. See [Figure A-1](#).

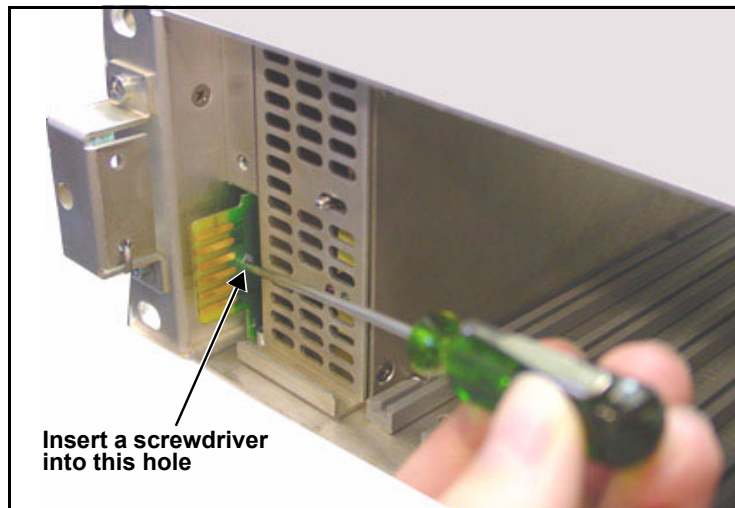

Figure A-1. Removing a Resource Card

Installing a New Resource Card

1. Pull out the finger-release screws on the right and left sides of the front panel, and then open it.
2. Slide the new card into the frame.
3. Close the front panel.

Symbols

+Pilot Lite software application 11

Numerics

2RU frame options 3
6800+ product line 2
6800/6800+ compatibility 3
6800/7000 series frames, installing modules 25
6802+PS and 6802+PS48
 description 9
 installation and usage 43–46
 specifications 48–51

A

AC power supply, maximum power ratings 14
AC/DC
 connections 32
 power supply description 9
accessories 3
adjustable parameters 41
alarms
 power supply 46
 state reporting 10
ambient temperature 16
assembly, fan 8

B

back panel
 description 7
 types 3
battery use caution 54
BNC coaxial cable connections 11
board controls 39

C

cable support bar, installing 18
card-edge controls 39
caution
 battery use 54
 fuse replacement 55
CCS
 network connections 36
 software application 12
clipping parameters 40
Command Control System (see "CCS") 12
communications
 control network 34
 frame 11
compliance information vi
configurations, frame 3, 11, 12
connections
 CCS network 36

- genlock 33
- GPI alarm relay to monitoring system 36
- system 32

control and monitor features 4, 10, 11

control network, identifying frames 35

controls, card-edge 39

cooling a frame 16

D

DC power supply, maximum power ratings 14

DC/AC

- connections 32
- power supply description 9

disconnecting a power supply 44

downloading Leitch manuals iv

E

electrical requirements 16

EMI gaskets 22

Ethernet connection 11, 12

extractor handle 23, 25

F

fans

- features 4, 8
- health monitoring 10
- installing 27
- replacing a failed fan unit 29

features, product 4

FR6802+FA fan assembly 27

frame

- description 2
- electrical requirements 16
- front panel description 6
- general frame description 4
- installing 18–20
- installing fans 27
- maximum power dissipation 17

- power ratings, maximum 14
- product packages 3
- rear panel description 7
- replacing failed fans 29
- signal flow 5
- specifications 48
- status LEDs 38
- status reporting 10
- system connections 32–36
- temperature and ventilation requirements 16

Frame ID rocker switches 35

front panel description 6

front panel LEDs 38

fuse replacement caution 55

G

genlock connections 33

GPI alarm relay, connecting 36

H

hex switch description 39

I

ICE6800+ Interface Card to Ethernet connections 12

identifying frames on the control network 35

installing

- fans 27
- frames 18–20
- frames and modules 14–36
- modules 21–25
- new resource card 56
- power supply 44

L

LEDs

- power supply 46
- status 38

load limitations, frames 16

M

main features 4

manual

ordering iv

revision history iii

writing conventions iv

maximum frame power ratings 14

maximum power dissipation 17

modules

installing 21–25

making connections 26

power consumption 17

removing 26

monitor and control features 4, 10, 11

monitoring systems, GPI alarm relay 36

N

network

creating a serial communication 34

frames 11

O

operating frames and modules 37–42

operating notes 42

options, frame 3

ordering Leitch manuals iv

over-voltage protection (OVP) 45

P

packing list 15

parameter types 40

power consumption 17

power source, making connections 32

power supply

features 4, 9

installation and usage 43–46

specifications 48

product description 2–3

product packages 3

protecting a power supply 45

PSU (see "power supply") 9

R

rack-mounting a frame 18

read-only parameters 41

rear panel description 7

rear-support brackets, installing 18

redundant power supply 44

remote control and monitoring 12

removing

fans 29

power supply 44

resource card 56

replacing

failed fan 29

resource card 56

reporting, frame 10

resource card

description 10

replacement 56

rotary switch description 39

RS-232 null modem serial cable connections 11

S

safety standards vi

serial communication network, creating 34

serial connection 11

servicing instructions 53–56

shipping information v

signal flow 5

specifications 47–51

status LEDs 38

status, frame 10

summary of frame operation steps 37
switches, control 39
symbols, safety vi
synchronizing signals, genlock connections 33
system
 configuration, Ethernet control 12
 configuration, serial control 11
 connections 32

T

temperature requirements, frame installation 16
termination 11
thermal protection 45
toggle switch description 40

U

unpacking/shipping information v, 15
upgrading frame with fan assembly 27

V

ventilation requirements, frame installation 16
voltage selection, frames 16

W

wrapping parameters 40

X

XLR connector 32

Trademarks and Copyright

AgileVision, BO/S, Broadcast Operating System, CCS, Command Control System, CCS CoPilot, CCS Navigator, CCS Pilot, DigiBus, DigiPeek, Digital Glue, DigiWorks, DPS, DTV Glue, EventWORKS, EZ HD, Genesis, HDTV Glue, Innovision, ISIS, JUNO, LeFont, Leitch, LogoMotion, MediaFile, MediaPort, MIX BOX, Monarch, NEO, the NEO design, OPUS, Panacea, PanelMAPPER, Portal, PROM-Slide, RouterMAPPER, RouterWORKS, StillFile, Still Net, SuiteView, Tekniche, Unilock, VIA, ViewGuard, Whiplash2, Xplus, and Leitch XPRESS are trademarks of Leitch Technology International Inc. which may be registered in the United States, Canada, and/or other countries.

All other trademarks are the property of their respective owners.

Copyright 2003-2005 Leitch Technology International Inc. All rights reserved.
This publication supersedes all previous releases. Printed in Canada.

Warranty

Leitch Incorporated ("Leitch") warrants to each original end-user purchaser or licensee (each, a "Customer") of hardware or software products manufactured by Leitch (each, a "Product"), or of non-warranty repair or other services provided by Leitch ("Services"), that each such Product and all such Services will be free from defects in materials and workmanship that adversely affect the Product's performance or the Services' intended purpose for a period (the "Warranty Period") of:

- One year for server hardware Products;
- Two years for non-server, and Desktop hardware Products;
- Ninety days for parts, assemblies and supplies to support hardware Products previously sold to Customers;
- Ninety days for media of software licensed separately from Leitch hardware Products, and encoding created by Leitch as physically affixed on or embedded in such media;
- The same period as the hardware Product warranty for media of software licensed as an integral part of any Leitch hardware Product, and encoding created by Leitch as physically affixed on or embedded in such media
- Ninety days for Services.

Please refer to the current "Leitch Limited Warranty Policy" for a complete description of the warranty provided, including important exclusions and limitations as well as procedures for obtaining warranty service.

[WORLDWIDE SUPPORT]

Leitch Technology is a 32-year global leader in the design and distribution of high-performance video systems for the professional television industry. Leitch offers the most extensible products and interoperable systems, enabling operations of any size to achieve a truly Integrated Content Environment. Leitch is the most trusted name for increasing performance and productivity through solutions that streamline workflow of content production, processing, transmission and management. With a sole focus on and commitment to the television industry, Leitch provides unparalleled customer support.

Leitch Americas

Support Headquarters

Phone: +1 (416) 642 3611
Toll Free: +1 (888) LEITCH6 (534 8246)
Fax: +1 (416) 445 9020
Email: service@leitch.com
Post Products: service.post@leitch.com

Server & AgileVision Products

Phone: +1 (818) 843 7004
Toll Free: +1 (888) 843 7004
Fax: +1 (818) 450 2199
Server Products: service.servers@leitch.com
AgileVision Products: service.agilevision@leitch.com

Leitch Europe

Europe & Africa - All Product Support

Phone: +44 1344 446099
Fax: +44 1344 446090
Email: service.europe@leitch.com
Post Products: service.post.eu@leitch.com

Leitch Asia

Asia/Pacific Rim - All Product Support

Phone: +852 2776 0628
Fax: +852 2776 0227
Email: service.asia@leitch.com
Post Products: service.post.asia@leitch.com

Please visit www.leitch.com/support/service for more information.

