

Control Accessories for Pro-video ENG Lenses and HDgc (KRS) Lenses

Recommended Kit Configuration

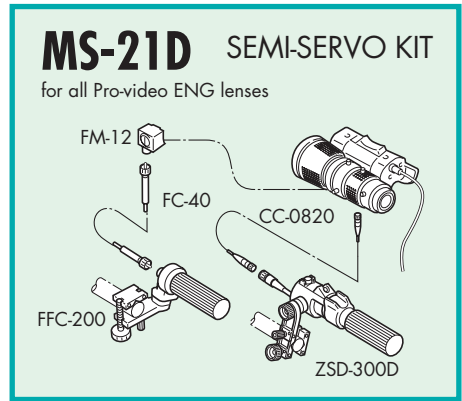
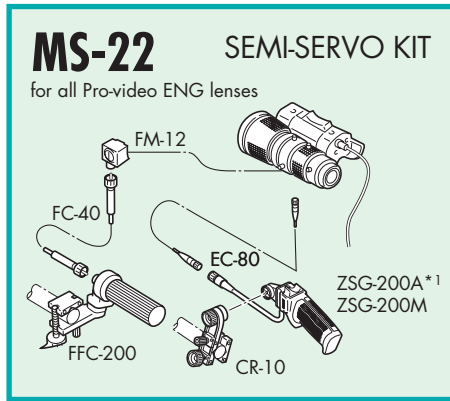
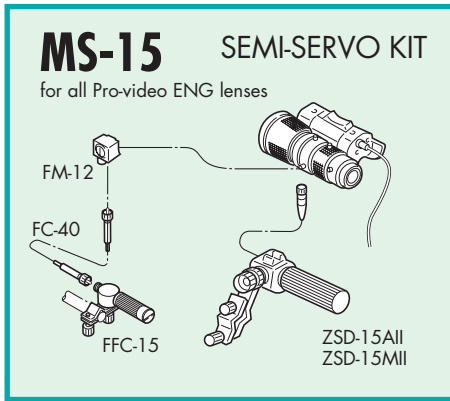

*A or M types, depends on applicable camera.

Applicable Component Detail

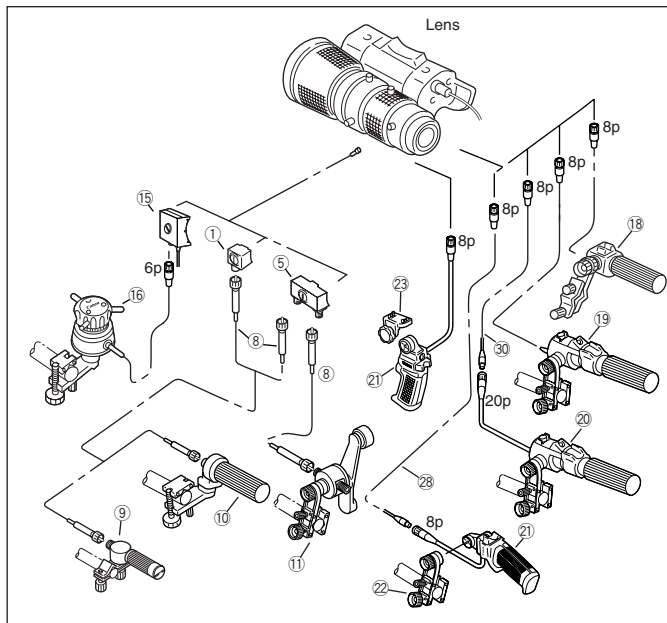

#	Unit	Description	CODE
①	FM-12	Flex Focus Module	1824A012
⑤	FM-70	Flex Dual Module	0002T071
⑧	FC-40	Flex Cable	1824A010
⑨	FFC-15	Flex Focus Controller	1824A024
⑩	FFC-200	Flex Focus Controller	1824A014
⑪	FZC-100	Flex Zoom Controller	1824A021
⑮	FPM-77	Focus Positional Servo Module	1824A020
⑯	FPD-400	Focus Positional Demand (*1)	1824A018
⑱	ZSD-15A II /M II	Zoom Demand	A 1824A070 M 1824A071
⑲	ZSD-300A/M	Zoom Demand (*1)	A 1824A066 M 1824A067
⑳	ZSD-300D	Zoom Demand	1824A123
㉑	ZSG-200A/M	Zoom Servo Grip (*1)	A 1824A068 M 1824A069
㉒	CR-10	Clamper	1824A007
㉓	GA-70	Grip Adapter	0018T531
㉔	EC-80	Zoom Extension Cable (8P)	1824A009
㉕	CC-0820	Conv. Cable (8pM-20pF)	1824A127

(*1) ZSD-300A/M, ZSG-200A and FPD-400 is not available

Applicable Kit Detail

Kit Name	Zoom		Focus	
	System	Component	System	Component

for KRS/IRS/VRS Type of Pro-video ENG Lenses

Zoom Servo Only	--	ZSD-15	⑱**	--	--
	--	ZR-1	⑲	--	--
	--	ZR-2(A)	㉑ ㉒ ㉔	--	--
	--	ZR-2(B)	㉑ ㉓*	--	--
Semi-Servo	MS-15	ZSD-15	⑱**	FRC-15	① ⑧ ⑨**
	MS-21	ZR-1	⑲	FR-2	① ⑧ ⑩
	MS-21D	ZR-1D	⑳ ㉕	FR-2	① ⑧ ⑩
	MS-22	ZR-2(A)	㉑ ㉒ ㉔	FR-2	① ⑧ ⑩
Full Servo	--	ZR-1	⑲	FPS-4	⑮ ⑯*
	--	ZR-2(A)	㉑ ㉒ ㉔	FPS-4	⑮ ⑯*
Full Manual	FZC-1	FZC-1	⑤* ⑧ ⑪	FR-2(w/o ①)	⑧ ⑩

*⑤ ⑯ & ㉓ are not applicable to YH14x7.3 and YH16x7.

**In USA, ⑱ & ⑨ are available only as MS-15 kit configuration and not as individual product.

MS-15 Recommended Kit Configuration for the Pro-video ENG lenses.

Remote Control Lens Series

The Canon Remote Control Series offers a wide variety of lenses and accessories that have been designed for various applications such as broadcasting, teleconference, distance learning and other remote control purposes. The lenses provide quiet and fast servo control of Zoom, Focus and Iris.

Broadcast Applications :

HDTV/SDTV



2/3" Series	HJ18ex28B ITS-ME	HJ22ex7.6B ITS-ME	HJ17ex7.7B ITS-ME	HJ17ex7.6B ITS-ME
Zoom Ratio	18x	22x	17x	17x
Built-in Extender	2.0x	2.0x	2.0x	2.0x
Range of Focal Length (with Extender)	28~500mm 56~1000mm (2.0x)	7.6~168mm 15.2~336mm (2.0x)	7.7~131mm 15.4~262mm (2.0x)	7.6~130mm 15.2~260mm (2.0x)

SDTV



2/3" Series	HJ11ex4.7B ITS-ME	J22ex7.6B ITS-ME	J17ex7.7B ITS-ME	J11ex4.5B ITS-ME
Zoom Ratio	11x	22x	17x	11x
Built-in Extender	2.0x	2.0x	2.0x	2.0x
Range of Focal Length (with Extender)	4.7~52mm 9.4~104mm (2.0x)	7.6~168mm 15.2~336mm (2.0x)	7.7~131mm 15.4~262mm (2.0x)	4.5~50mm 9~100mm (2.0x)

*Please refer to page 22-25 for more detailed specifications.

*The 2X extender of ITS-ME model is manually operated. ITS-RE model which has a motorized 2X extender is also available and will look like YJ20x8.5B ITS on page 43.

Pro-video Applications :



2/3" Series	YJ20x8.5B ITS	YJ20x8.5B KTS	YJ13x6B KTS
Zoom Ratio	20x	20x	13x
Built-in Extender	2.0x	—	—
Range of Focal Length (with Extender)	8.5~170mm 17~340mm (2.0x)	8.5~170mm	6~78mm



1/2" Series	KH19x6.7-II KTS*1
Zoom Ratio	19x
Range of Focal Length	6.7~127mm

Control Accessories for Remote Control Lenses

The Canon Remote Control TV Lenses and standard controller system are engineered to satisfy your image capture needs. These broadcast quality products can be used in applications which differ from typical video production applications, such as fast and quiet servo operations. The Canon Remote Control TV Lenses accept 3 types of Canon standard controllers, as well as the standard remote control cables, which are designed to provide different types of zoom, focus and iris remote control. These lenses are also available with a simple interface for use with custom controllers.

System Configuration

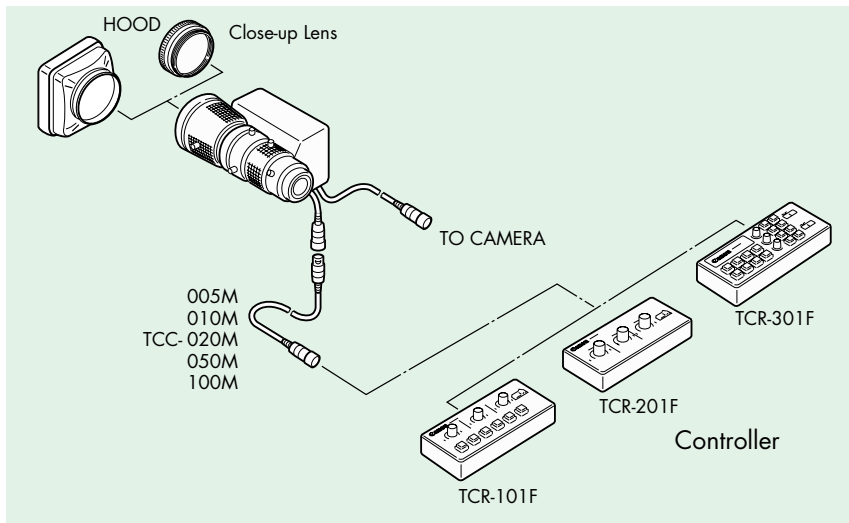

Controller

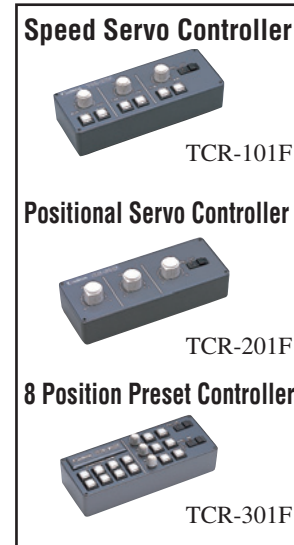

Close-up Lens (not available for HJ18ex/HJ11ex/J11ex)

Four types (82CL-UP800H / 82CL-UP1300H / 105CL-UP900H / 105CL-UP800HD) are available.

*Please refer to page 42 for the applications

Remote Controller

Three types (TCR-101F, TCR-201F, TCR-301F) are available.

Connecting Cable

5m, 10m, 20m, 50m and 100m cables are available.

Maximum cable length is 150m by connection of these cables.

External Extender (For 2/3" Lens Only)

A 2X extender is available for telephoto shooting.

For the ITS-RE model of the Broadcast Remote Control Lenses and for the YJ20x8.5B ITS, the 2x extender is motorized and can be remote controlled.

*Please inquire to Canon Sales Office for extender remote control interface.

Optical Accessories for SDTV and HDTV ENG/EFP Lenses

SYSTEM

1. CONVERTERS/ATTACHMENTS

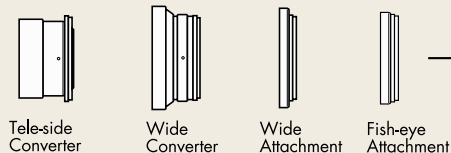

2. FILTERS



3. CLOSE UP LENSES

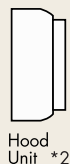
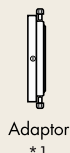

4. EXTENDERS

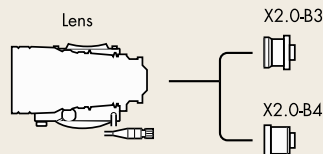

*1: Most Canon Converters and Attachments use a separate adaptor ring as shown in the table on page 45, which allow compatibility between several lens models. The W80Y-85 is special Wide Converter and is exclusive to certain lens models as shown in the table on page 45.

*2: Some lens models allow for the filter to be attached to the threaded lens barrel, in other models, the filter is attached to the threaded hood unit. For lens model filter size compatibility, please refer to page 47.

1. CONVERTERS/ATTACHMENTS

TELE-SIDE CONVERTER



- Focal length is shifted to the telephoto side by a factor of 1.5x.
- F No. of the original lens is not affected.
- Only the telephoto side of the lens can be used, the picture corners are eclipsed at wide angle.
- The minimum object distance becomes 2.25 times that of the original lens.



	M.O.D	Eclipse Point
J22ex7.6B	1.75m	f:70mm
J17ex7.7B	1.35m	f:60mm
YJ20x8.5B	2.00m	f:80mm

WIDE CONVERTER



- Focal length becomes wider by a factor of 0.8x that of the original lens with the W80 / W80Y-85.
- F No. of the original lens is not affected.
- The minimum object distance becomes 0.64 times with the W80 / W80Y-85.



Change in focal length

	Master Lens	With Wide Con.
J22ex7.6B	7.6-168mm	6.1-134mm
J17ex7.7B	7.7-131mm	6.2-104.8mm
YJ20x8.5B	8.5-170mm	6.8-136mm

WIDE ATTACHMENT



- The zoom lens becomes a wider fixed focal length lens with the wide attachment.
- The focal length is widened by a factor of 0.75x that of the original lens.
- Focus is adjusted by use of the macro lever.



Change in focal length

	Master Lens	With Wide Attach.
J22ex7.6B	7.6-168mm	5.7mm
J17ex7.7B	7.7-131mm	5.8mm
YJ20x8.5B	8.5-170mm	6.4mm

FISH-EYE ATTACHMENT







- The zoom lens becomes a fish-eye fixed focal length lens (distorted image) with the fish-eye attachment.
- The focal length is widened by a factor of approximately 0.6x that of the original lens.
- Focus is adjusted by use of the macro lever.

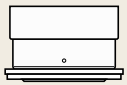
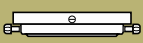
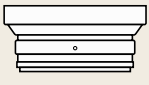
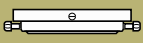

Change in focal length

	Master Lens	With Fish-Eye
J22ex7.6B	7.6-168mm	4.6mm
J17ex7.7B	7.7-131mm	4.6mm
YJ20x8.5B	8.5-170mm	5.1mm

[Applications of SDTV and HDTV Adaptor Type Converters / Attachments]

CONVERTER/ ATTACHMENT TYPE	MODEL NAME	CODE	APPLICABLE LENS					
			J17ex7.7B J17ax7.7B YJ20x8.5B YJ19x9B YH19x6.7	KJ16ex7.7B*1 KJ20x8.5B*1 KH16ex5.7*1 KH20x6.4*1 KT20x5*1	HJ17ex7.6B KJ16ex7.7B KJ20x8.5B KH16ex5.7 KH20x6.4 KT20x5	J22ex7.6B J21ax7.8B KJ21ex7.7B*1 KH21ex5.7*1	HJ22ex7.6B HJ21ex7.8B HJ17ex7.7B KJ21ex7.6B KH21ex5.7	
Front Lens Diameter			φ 85mm		φ 98mm			
Tele-side Converter		T15-II	1823A005					
		T15HD	0025T799					
		Adaptor85II	1824A002					
		Adaptor98II	1824A004					
Wide Converter		W80-III B	1823A006					
		W80HD	1823A094					
		Adaptor85II	1824A002					
		Adaptor98II	1824A004					
Wide Attachment		WA75-II	1823A008					
		WA75HD	1823A095					
		Adaptor85II	1824A002					
		Adaptor98II	1824A004					
Fish-eye Attachment		FEA-III B	1823A011					
		FEA-HD	1823A099					
		Adaptor85II	1824A002					
		Adaptor98II	1824A004					

*1 The HD quality accessories offer higher optical performance.

• When purchasing, please specify model name of both Body and Adaptor.

• It is possible to use Body and Adaptor in different combinations. But it is impossible to use in combinations not shown in above table.

• Focus servo operation is possible with IF lenses only.

[Applications of Exclusive Wide Converter]

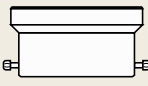
Wide Converter	 W80Y-85	W80Y-85	1823A009	Exclusively designed for YJ18x9B/YJ19x9B/YJ20x8.5B/YH18x6.7/ YH19x6.7/KT20x5/KH20x6.4/KJ20x5. The adaptor parts are integrated into the main body. (Also known as the Crossover Adaptor, see page 40)				
-------------------	--	---------	----------	--	--	--	--	--

2. FILTERS

UV/CLEAR/SKY LIGHT FILTER

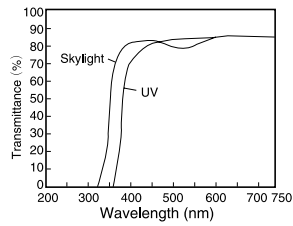

- A UV (ultraviolet) filter is nearly colorless. It absorbs short-wavelength ultraviolet rays that the naked eye cannot see.
- A Skylight Filter has a light pinkish color. Used when shooting on clear days, it removes ultraviolet, and prevents natural light from giving a bluish-green cast to shaded foliage etc.
- These filters are also advisable to protect the front lens surface.

CROSS/SNOW CROSS/SUNNY CROSS FILTER



- A Cross Filter creates a cross or star of light by scattering rays from a strong light source in the subject in a radial pattern. The brighter and more pointlike the subject is, the better the effect is. Cross Filters are often used to enhance night scenery or stage show broadcasts.

<Types of Cross Filter>

- Cross Filter ; Scatters light in a four-pointed cross.
- Snow Cross Filter ; Scatters light in a six-pointed star.
- Sunny Cross Filter ; Scatters light in an eight-pointed star.

POLARIZED LIGHT FILTER



- A polarizer is used to intercept light reflected from the surface of water or glass.
- A polarizer is screwed into the threads of the hood, turned, and stopped in the position in which the reflected light is removed.

SOFTON FILTER



- A Soft-focus Filter has a mat-like surface that imparts a soft, misty effect to the entire picture.
- Soft-focus Filters are frequently used for lyric scenery shots.

ND4/ND8 FILTER



- An ND (neutral density) Filter uniformly reduces light of all wavelengths which enters a lens.
- It is used when the subject is too bright for the light to be adjusted by the diaphragm alone.
- An ND Filter is also effective to create a shallow depth of field.

ND filter type	Transmittance	Density
ND4	25%	0.6
ND8	12.5%	0.9

3. CLOSE-UP LENSES

CLOSE-UP LENS



- A close-up lens is used to shorten the M.O.D. of the master lens for close-up shooting.
- The maximum object distance becomes the focal length of the close-up lens.
- The minimum object distance is calculated by the following formula.
New minimum object distance = $fc \times S / (fc + S)$
fc = Focal length of the close-up lens
S = M.O.D. of the master lens

Imaging range for J17ex7.7B, and YJ20x8.5B with close-up lenses

	82CL-UP800H				82CL-UP1300H				
	Tele end : 131mm		Wide end : 7.7mm		Tele end : 131mm		Wide end : 7.7mm		
J17ex7.7B	Focusing Scale(mm)	∞	0.6	∞	0.6	∞	0.6	∞	0.6
	Object Distance(mm)	800	340	800	340	1300	407	1300	407
	Object Dimensions(mm)	53x40	21x16	908x681	341x256	87x65	25x19	1499x1124	411x308
YJ20x8.5B	Tele end : 170mm		Wide end : 8.5mm		Tele end : 170mm		Wide end : 8.5mm		
	Focusing Scale(mm)	∞	0.9	∞	0.9	∞	0.9	∞	0.9
	Object Distance(mm)	800	420	800	420	1300	530	1300	530
Object Dimensions(mm)	41x31	20x15	816x609	390x293	67x50	26x20	1341x1006	494x371	

Model	Code	APPLICABLE LENSES
82CL-UP800H	1823A041	J17ex7.7B, J17ax7.7B, YJ20x8.5B, YJ19x9B, KJ16ex7.7B, KJ20x8.5B, KH16ex5.7, KH20x6.4, KT20x5
82CL-UP1300H	1823A042	J17ex7.7B, J17ax7.7B, YJ20x8.5B, YJ19x9B, KJ16ex7.7B, KJ20x8.5B, KH16ex5.7, KH20x6.4, KT20x5
105CL-UP900H	1823A043	J22ex7.6B, J21ax7.8B, KJ21ex7.6B*, KH21ex5.7*
105CL-UP800HD	1823A096	HJ22ex7.6B, HJ21ex7.8B, HJ17ex7.7B, KJ21ex7.6B, KH21ex5.7

* The HD quality accessories offer higher optical performance.

[Application of Filters]

FILTER TYPE	MODEL NAME	CODE	APPLICABLE LENSES						
			HJ18ex28B HJ21ex7.5B HJ21x7.5B HJ11ex4.7B HJ11x4.7B J11ex4.5B J11ax4.5B KJ10ex4.5B KH10ex3.6	HJ40x14B HJ40x10B	J35ex15B J35ex11B J33ax15B J33ax11B H33ax11 PH33ax8.5B	HJ18x7.8B KJ13x6B KH13x4.5 YJ13x6B YJ12x6.5B YH12x4.8	HJ22ex7.6B HJ21ex7.8B HJ21x7.8B HJ17ex7.7B J22ex7.6B J21ax7.8B KJ21ex7.6B KH21ex5.7	HJ17ex7.6B J17ex7.7B KJ16ex7.7B KH16ex5.7 KJ20x8.5B KH20x6.4 KT20x5 YJ20x8.5B YJ19x9B YH19x6.7	YH16x7
Hood Unit Thread Size			127mm P0.75	—	—	105mm P1	105mm P1	—	82mm P0.75
Lens Barrel Thread Size			—	127mm P0.75	125mm P1	—	94mm P1	82mm P0.75	72mm P0.75
UV	UV/127P0.75	1823A083	●	●					
	UV/105P1	1823A022				●	●		
	UV/94P1	1823A021					●		
	UV/82P0.75	1823A030						●	●
Clear	CL/127	1823A093	●	●					
	CL/125	1823A044			●				
Sky Light	SKY/105P1	1823A023				●	●		
	SKY/82P0.75	1823A031						●	●
Cross	CRS/127P0.75	1823A085	●	●					
	CRS/105P1	1823A024				●	●		
	CRS/82P0.75	1823A032						●	●
Snow Cross	SNW/127P0.75	1823A087	●	●					
	SNW/105P1	1823A047				●	●		
	SNW/82P0.75	1823A034						●	●
Sunny Cross	SNY/127P0.75	1823A088	●	●					
	SNY/105P1	1823A025				●	●		
	SNY/82P0.75	1823A033						●	●
Polarized Light	PL/127P0.75	1823A090	●	●					
	PL/105P1	1823A028				●	●		
	PL/82P0.75	1823A038						●	●
Softon	SFT/127P0.75	1823A089	●	●					
	SFT/105P1	1823A027				●	●		
	SFT/82P0.75	1823A037						●	●
ND	ND8/127P0.75	1823A086	●	●					
	ND4/82P0.75	1823A035						●	●
	ND8/105P1	1823A026				●	●		
	ND8/82P0.75	1823A036						●	●

●Note; Hood Unit Thread Filter and Lens Barrel Thread Filter cannot be mounted together because of mechanical interference.

4. EXTENDERS



- An extender X2.0-B4 is mounted between the camera and the lens to enlarge the image of the subject.
- It doubles the focal length of the master lens, making it into a more telephoto lens.
- The 2.0x Extender also doubles the F-number.

	Master Lens	With Extender
YJ20x8.5B	Focal length 8.5-170mm	17-340mm
	F-number 1.8-2.7	3.6-5.4

*Only for 2/3" lenses

Model	Code	APPLICABLE LENSES
X2.0-B3	1823A001	Applicable to all B3 type mount Canon 2/3" lenses.
X2.0-B4	1823A002	Applicable to all B4 type mount Canon 2/3" lenses.



North & South America

Canon U.S.A., Inc.

Broadcast and Communications Div. (Headquarters)
65 Challenger Road, Ridgefield Park, NJ 07660
Tel:(201)807-3300 / (800)321-4388
Fax:(201)807-3333
Email:bctv@cusa.canon.com
<http://www.canonbroadcast.com/>

Chicago

100 Park Blvd. Itasca, IL 60143
Tel:(630)250-6236 Fax:(630)250-0399

Atlanta

5625 Oakbrook Pkwy. Norcross, GA 30093
Tel:(770)849-7890 Fax:(770)849-7888

Los Angeles

15955 Alton Parkway Irvine, CA 92618
Tel:(949)753-4330 Fax:(949)753-4337

Dallas

3200 Regent Blvd. Irving, TX 75063
Tel:(972)409-8871 Fax:(972)409-8869

Latin America

Tel:(954)349-6975 Fax:(201)807-3333

Canada

Canon Canada, Inc.

Broadcast and Communications Div.
6390 Dixie Road
Mississauga, Ontario, L5T 1P7, Canada
Tel:(905)795-2012 Fax:(905)795-2140

Europe/Africa/Middle East

Canon Europa N.V.

Broadcast and Communications Div.
Bovenkerkerweg 59-61
1185 XB Amstelveen
Tel:+31(0)20-5458905 Fax:+31(0)20-5458203
Email:tvprod@canon-europe.com
<http://www.canon-europe.com/tv-products>

Australia

Canon Australia Pty. Ltd.

Optical Products Division
1 Thomas Holt Drive, North Ryde, NSW 2113, Australia
Tel:+61(0)2-9805-2000 Fax:+61(0)2-9805-2444

China

Canon (China) Co., Ltd.

Optical Products Division
15F Jinbao Building No.89 Jinbao Street
Dongcheng District, Beijing 100005, China
Tel:86-10-85139999 Fax:86-10-85139902
<http://www.canon.com.cn>

Asia/Japan

Canon Inc.(Broadcast Equipment Group)

23-10, Kiyohara-Kogyo-Danchi, Utsunomiya-shi,
Tochigi-ken, 321-3298, Japan
Tel:+81(0)28-667-8669 Fax:+81(0)28-667-8672
<http://www.canon.com/bctv/>

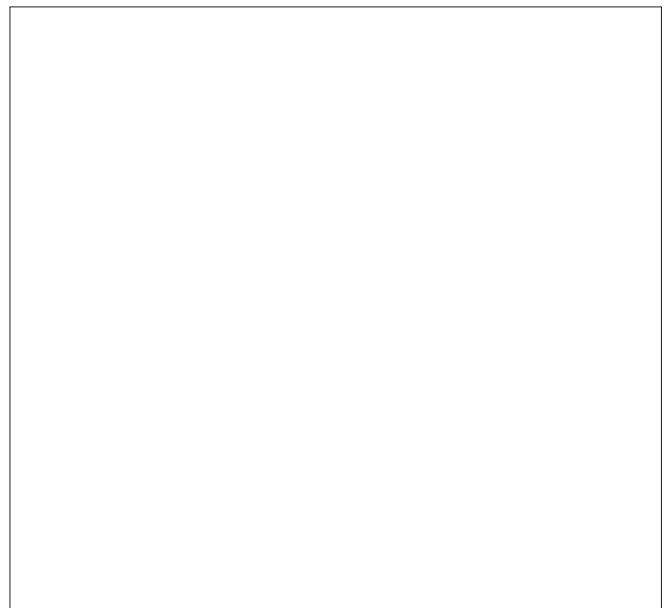

Canon

- The size and weight of all lenses within this brochure may vary according to the applicable camera models.
- Specifications subject to change without notice