

Instructions for Use

RadiForce® RX850

Color LCD monitor

Important









Please read this “Instructions for Use”, and “Installation Manual” (separate volume) carefully to familiarize yourself with safe and effective usage.

Please retain this manual for future reference.

-
- For monitor adjustment and settings, refer to the “Installation Manual”.
 - For the latest product information including the “Instructions for Use”, refer to our web site :
<http://www.eizoglobal.com>
-

SAFETY SYMBOLS

This manual and this product use the safety symbols below. They denote critical information. Please read them carefully.

 <p>WARNING Failure to abide by the information in a WARNING may result in serious injury and can be life threatening.</p>	 <p>CAUTION Failure to abide by the information in a CAUTION may result in moderate injury and/or property or product damage.</p>
	<p>Indicates a warning or caution. For example,  indicates an “electrical shock” hazard.</p>
	<p>Indicates a prohibited action. For example,  means “Do not disassemble”.</p>
	<p>Indicates a mandatory action. For example,  means “Ground the unit”.</p>

This product has been adjusted specifically for use in the region to which it was originally shipped. If operated outside this region, the product may not perform as stated in the specifications.

No part of this manual may be reproduced, stored in a retrieval system, or transmitted, in any form or by any means, electronic, mechanical, or otherwise, without the prior written permission of EIZO Corporation. EIZO Corporation is under no obligation to hold any submitted material or information confidential unless prior arrangements are made pursuant to EIZO Corporation’s receipt of said information. Although every effort has been made to ensure that this manual provides up-to-date information, please note that EIZO monitor specifications are subject to change without notice.

PRECAUTIONS

IMPORTANT

- This product has been adjusted specifically for use in the region to which it was originally shipped. If the product is used outside the region, it may not operate as specified in the specifications.
- For personal safety and proper maintenance, please read carefully this section and the caution statements on the monitor.

Location of the caution statements

Monitor

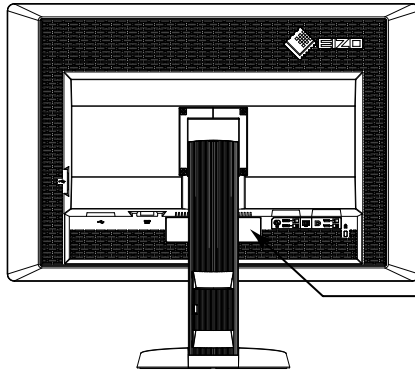





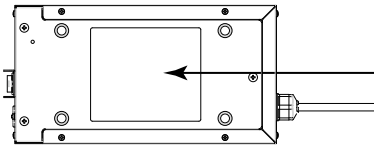







WARNING
 RISK OF ELECTRIC SHOCK. DO NOT OPEN.
AVERTISSEMENT
 RISQUE DE CHOC ELECTRIQUE. NE PAS OUVRIR.
WARNUNG
 GEFAHR DES ELEKTRISCHEN SCHLAGES. RÜCKWAND NICHT ENTFERNEN.
警告
 触电危険、请勿打开后盖。
警告
 感電の恐れあり、カバーをあけないでください。
 AC/DC Adapter Model: PSA-073
 交流/直流 适配器 型号: PSA-073

AC adapter



CAUTION: RISK OF ELECTRIC SHOCK, DO NOT OPEN.
 DOUBLE POLE, NEUTRAL FUSING.
ATTENTION: RISQUE DE CHOC ELECTRIQUE. NE PAS OUVRIR.
 DOUBLE POLE, FUSIBLE SUR LE NEUTRE.
ACHTUNG: GEFAHR DES ELEKTRISCHEN SCHLAGES. RÜCKWAND NICHT
 ENTFERNEN. ZWEPOLIGE BZW. NEUTRALLEITER-SICHERUNG.
注意: 有触电的危险。请勿打开。双极/中线熔断。
注意: 重要注意 非专业人员请勿打开机壳 内部有多处高压部分 万一误操作有危险
 发生。中即报警。
注意: 高压注意。感電の恐れあり、カバーをあけないでください。
 2極/中性点ヒューズ。
 The equipment must be connected to a grounded main outlet,
 Jordet sikkerkontakt skal benyttes når apparatet tilkøobles datanett.
 Apparatet skall anslutas till jordat nätuttag.
 这设备必须连接至接地主插座。
 這設備必須連接至接地主插座
 電源コードのアースは必ず接地してください。

Symbols on the unit

Symbol	This symbol indicates	
	AC adapter main power switch:	Press to turn the monitor's main power off.
	AC adapter main power switch:	Press to turn the monitor's main power on.
	Power switch:	Touch to turn the monitor's power on or off.
	Alternating current	
	Direct current	
	Electrical shock hazard	
	CAUTION:	Refer to "SAFETY SYMBOLS" (page 2).
	WEEE marking:	Product must be disposed of separately; materials may be recycled.
	CE marking:	EU conformity mark in accordance with the provisions of Council Directive 93/42/EEC and 2011/65EU.
	Manufacturer	
	Date of manufacture	

WARNING

If the unit begins to emit smoke, smells like something is burning, or makes strange noises, disconnect all power connections immediately and contact your EIZO representative for advice.
Attempting to use a malfunctioning unit may result in fire, electric shock, or equipment damage.

Do not open the cabinet or modify the unit.

Opening the cabinet or modifying the unit may result in fire, electric shock, or burn.



Do not turn the bushing for fixing the AC adapter power cable.

Not doing so may result in fire, electric shock, or equipment damage.



Refer all servicing to qualified service personnel.

Do not attempt to service this product yourself as opening or removing covers may result in fire, electric shock, or equipment damage.

Keep small objects or liquids away from the unit.

Small objects accidentally falling through the ventilation slots into the cabinet or spillage into the cabinet may result in fire, electric shock, or equipment damage. If an object or liquid falls/spills into the cabinet, unplug the unit immediately. Have the unit checked by a qualified service engineer before using it again.



Place the unit at the strong and stable place.

A unit placed on an inadequate surface may fall and result in injury or equipment damage. If the unit falls, disconnect the power immediately and ask your local EIZO representative for advice. Do not continue using a damaged unit. Using a damaged unit may result in fire or electric shock.



Use the unit in an appropriate location.

Not doing so may result in fire, electric shock, or equipment damage.

- Do not place outdoors.
- Do not place in the transportation system (ship, aircraft, trains, automobiles, etc.)
- Do not place in a dusty or humid environment.
- Do not place in a location where water is splashed on the screen (bathroom, kitchen, etc.).
- Do not place in a location where the steam comes directly on the screen.
- Do not place near heat generating devices or a humidifier.
- Do not place in a location where the product is subject to direct sunlight.
- Do not place in an inflammable gas environment.
- Do not place in environments with corrosive gases (such as sulfur dioxide, hydrogen sulfide, nitrogen dioxide, chlorine, ammonia, and ozone).
- Do not place in environments with dust, components that accelerate corrosion in the atmosphere (such as sodium chloride and sulfur), conductive metals, and so on.



To avoid danger of suffocation, keep plastic packing bags away from babies and children.

Use the enclosed AC adapter.

The enclosed AC adapter (PSA-073) is for use with this product only. Do not use the AC adapter with other equipment. Connecting to power sources that do not match the power ratings of the AC adapter may result in fire or electric shock.

Use the enclosed power cord and connect to the standard power outlet of your country.

Be sure to remain within the rated voltage of the power cord. Not doing so may result in fire or electric shock.
Power supply: 100-120/200-240Vac 50/60Hz

WARNING

To disconnect the power cord or adapter power cable, grasp the plug firmly and pull.

Tugging on the cord or cable may damage and result in fire or electric shock.



The equipment must be connected to a grounded main outlet.

Failure to do so may result in fire or electric shock.



Use the correct voltage.

- The unit is designed for use with a specific voltage only. Connection to another voltage than specified in this manual may cause fire, electric shock, or equipment damage.
Power supply: 100-120/200-240Vac 50/60Hz
- Do not overload your power circuit, as this may result in fire or electric shock.

Handle the power cord and AC adapter with care.

Handle the power cord and AC adapter with care.

Do not place heavy objects on, pull or tie the power cord or the AC adapter. Using a damaged cord or AC adapter may result in fire or electric shock.



For electrical safety, do not connect or disconnect the power cord in the presence of patients.

Never touch the plug, AC adapter or power cord during a thunderstorm.

Touching them may result in electric shock.



When attaching an arm stand, please refer to the user's manual of the arm stand and install the unit securely.

Not doing so may cause the unit to become unattached, which may result in injury or equipment damage.

Before installation, make sure that desks, walls, and others an arm stand is fixed on have adequate mechanical strength. When the unit is dropped, please ask your local EIZO representative for advice. Do not continue using a damaged unit. Using a damaged unit may result in fire or electric shock. When reattaching the tilt stand, please use the same screws and tighten them securely.

Do not touch a damaged LCD panel directly with bare hands.

The liquid crystal that may leak from the panel is poisonous if it enters the eyes or mouth. If any part of the skin or body comes in direct contact with the panel, please wash thoroughly. If some physical symptoms result, please consult your doctor.



Fluorescent backlight lamps contain mercury (products that have LED backlight lamps contain no mercury), dispose according to local, state or federal laws.

Exposure to elemental mercury can result in effects on the nervous system, including tremor, memory loss, and headache.

CAUTION

Handle with care when carrying the unit.

Disconnect the power cord and cables when moving the unit. Moving the unit with the cord attached is dangerous.

It may result in injury.

Carry or place the unit according to the correct specified methods.

- When carrying the unit, grasp and hold firmly as shown in the illustration below.
- Do not unpack or carry the unit only by a single person, since the large size unit is so heavy.

Dropping the unit may result in injury or equipment damage.

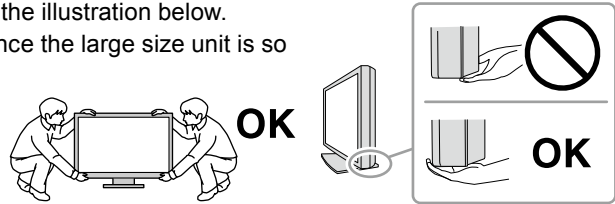

Do not block the ventilation slots on the cabinet.

- Do not place any objects on the ventilation slots.
- Do not install the unit in a closed space.
- Do not use the unit laid down or upside down.

Blocking the ventilation slots prevents proper airflow and may result in fire, electric shock, or equipment damage.



Do not touch the plug or AC adapter with wet hands.

Doing so may result in electrical shock.



Use an easily accessible power outlet.

This will ensure that you can disconnect the power quickly in case of a problem.

Mind that the AC adapter becomes hot during use.

- Do not cover or place anything on top of the AC adapter. Do not place the AC adapter on top of things that trap heat such as carpets, blankets, etc. Keep the AC adapter away from direct sunlight and heat sources such as heaters. Not doing so may result in fire.
- Do not touch with bare hands. Doing so may result in burns.
- Before moving the monitor, be sure to turn off the power switch, disconnect the power plug from the power outlet, and wait until it has cooled completely.

Do not suspend the AC adapter in midair.

Using it while suspended in midair may result in fire or electric shock.



Periodically clean the area around the power plug and the ventilation slot of the monitor and the AC adapter.

Dust, water, or oil on the plug may result in fire.

Unplug the unit before cleaning it.

Cleaning the unit while it is plugged into a power outlet may result in electric shock.

If you plan to leave the unit unused for an extended period, disconnect the power cord from the wall socket after turning off the power switch for the safety and the power conservation.

This product is only suitable for a patient environment, but not for contact with a patient.

Notice for this monitor

This product is intended to be used in displaying and viewing digital images, including standard and multi-frame digital mammography, for review, analysis and diagnosis by trained medical practitioners. It is specially designed for breast tomosynthesis applications.

Caution: Federal law (USA) restricts this device to sale by or on the order of a physician.

This product should be set to horizontal view mode when used for the purposes mentioned above.

This product has been adjusted specifically for use in the region to which it was originally shipped. If the product is used outside the region, it may not operate as specified in the specifications.

This product may not be covered by warranty for uses other than those described in this manual.

The specifications noted in this manual are only applicable when the following are used:

- Power cords provided with the product
 - Signal cables specified by us
-

Only use optional products manufactured or specified by us with this product.

It takes about 30 minutes for the performance of electrical parts to stabilize. Please wait 30 minutes or more after the monitor power has been turned on or the monitor has recovered from the power saving mode, and then adjust the monitor.

It takes about a few minutes for the image quality to reach acceptable level. Please wait a few minutes or more after the monitor power has been turned on or the monitor has recovered from the power saving mode, and then view images for diagnosis.

Monitors should be set to a lower brightness to reduce changes in luminosity caused by long-term use and maintain a stable display. In addition, perform a calibration and Constancy test (including Grayscale Check) on a periodic basis (refer to "Controlling Monitor Quality" in the Installation Manual).

When the screen image is changed after displaying the same image for extended periods of time, an afterimage may appear. Use the screen saver or power save function to avoid displaying the same image for extended periods of time.

If you place this product on a lacquer-coated desk, the color may adhere to the bottom of the stand due to the composition of the rubber. Check the desk surface before use.

Periodic cleaning is recommended to keep the monitor looking new and to prolong its operation lifetime (refer to "Cleaning" (page 8)).

The screen may have defective pixels or a small number of light dots on the screen. This is due to the characteristics of the panel itself, and is not a malfunction of the product.

The backlight of the LCD panel has a fixed lifetime. When the screen becomes dark or begins to flicker, please contact your local EIZO representative.

Do not press on the panel or edge of the frame strongly, as this may result in display malfunctions, such as interference patterns, etc. If pressure is continually applied to the panel, it may deteriorate or damage your panel. (If the pressure marks remain on the panel, leave the monitor with a black or white screen. The symptom may disappear.)

Do not scratch or press on the panel with any sharp objects, as this may result in damage to the panel. Do not attempt to brush with tissues as this may scratch the panel.

When the monitor is cold and brought into a room or the room temperature goes up quickly, dew condensation may occur on the interior and exterior surfaces of the monitor. In that case, do not turn the monitor on. Instead wait until the dew condensation disappears, otherwise it may cause some damage to the monitor.

Cleaning

Attention

- Do not use chemicals on a frequent basis. Chemicals such as alcohol and antiseptic solution may cause gloss variation, tarnishing, and fading of the cabinet or panel, and also quality deterioration of the image.
 - Never use any thinner, benzene, wax, and abrasive cleaner, which may damage the cabinet or panel.
 - Do not let chemicals come into direct contact with the monitor.
-

Note

- The optional ScreenCleaner is recommended for cleaning the cabinet and panel surface.
-

Gently wipe off any dirt on the cabinet or panel surface with a soft cloth soaked in a small amount of water or one of the chemicals listed below.

Chemicals that may be used for cleaning

Material name	Product name
Ethanol	Ethanol
Isopropyl alcohol	Isopropyl alcohol
Chlorhexidine	Hibitane
Sodium hypochlorite	Purelox
Benzalkonium chloride	Welpas
Alkyldiaminoethylglycine	Tego 51
Glutaral	SteriHyde
Glutaral	Cidex Plus28

To use the monitor comfortably

- An excessively dark or bright screen may affect your eyes. Adjust the brightness of the monitor according to the environmental conditions.
- Staring at the monitor for a long time tires your eyes. Take a 10-minute rest every hour.

CONTENTS

PRECAUTIONS	3
IMPORTANT	3
Notice for this monitor	7
Cleaning	8
To use the monitor comfortably	8
CONTENTS	9
Chapter 1 Introduction	10
1-1. Features	10
1-2. Package Contents	11
1-3. EIZO LCD Utility Disk	11
● Disk contents and software overview	11
● Using RadiCS LE/ScreenManager Pro for Medical	11
1-4. Controls and Functions	12
Chapter 2 Setting Up	13
2-1. Compatible Resolutions	13
2-2. Connecting Cables	14
2-3. Adjusting the Screen Height and Angle	15
2-4. Attaching a Power Cord Holder	16
Chapter 3 Troubleshooting	17
Chapter 4 Specifications	19
Chapter 5 Glossary	22
Appendix	24
Trademark	24
License	24
Medical Standard	25
EMC Information	26
FCC Declaration of Conformity	31

Chapter 1 Introduction

Thank you very much for choosing an EIZO color LCD monitor.

1-1. Features

- 31.1 inches
- Wide-gamut panel
 - *1 Displayed image colors may appear to have a different tint than sRGB-enabled monitors due to the different color gamut.
- Supports to the resolution of 8M pixels (4096 × 2160 dots)
- Uses high-contrast panel (1450:1).
Enables the display of sharp images.
- Applicable to DisplayPort (applicable to 8 bit or 10 bit, not applicable to audio signals)
- The “PbyP (Picture by Picture)” function enables the display of two signals at the same time.
A bezel-less widescreen offers less strain on the eyes and higher work efficiency compared to having two monitors side by side.
- The Hybrid Gamma function automatically identifies the display area for the monochrome and color images on the same screen, and displays each set status.
 - *2 The identification may fail depending on the displayed image. The software to be used needs to be verified. For validation, refer to the Installation Manual (on the CD-ROM).
- The RadiCS SelfQC function and the built-in Integrated Front Sensor allow the user to perform the calibration and Grayscale Check for the monitor independently.
Refer to the Installation Manual (on the CD-ROM).
- The CAL Switch function allows the user to select the display mode optimum to the displayed image.
Refer to the Installation Manual (on the CD-ROM).
- Selectable DICOM (page 22) Part 14 complied screen.
- The quality control software “RadiCS LE” used to calibrate the monitor and to manage the history is included.
See “1-3. EIZO LCD Utility Disk” (page 11).
- The software “ScreenManager Pro for Medical” to adjust the screen using the mouse and keyboard is included
See “1-3. EIZO LCD Utility Disk” (page 11).
- Power saving function
This product is equipped with power saving function.
 - 0 W power consumption when the main power is off
Equipped with main power switch.
When the monitor is not required, the power supply can be shut off using the main power switch
 - Presence Sensor
The sensor on the front side of the monitor detects the movement of a person. When a person moves away from the monitor, the monitor shifts to the power saving mode automatically and does not display the images on the screen. Therefore, the function reduces the power consumption. The sensitivity and time until the power saving mode is activated can be set according to the monitor usage environment and movement of the user.
Refer to the Installation Manual (on the CD-ROM).
- Space-saving thinner and lighter design
- Long service life LED backlight LCD panel
- Built-in ambient light sensor
Depending on the environment, the sensor sometimes indicates different values from those measured by a stand-alone illuminance meter.
The usage of this sensor requires the quality control software “RadiCS/RadiCS LE” and the measurement is always triggered by the user’s operation in the corresponding menu.
For further details about the measured value and how to execute the measurement, refer to the RadiCS/ RadiCS LE User’s Manual (on the CD-ROM).
- Displays HDCP (High-bandwidth Digital Content Protection) protected contents (DisplayPort only).

Attention

- A high temperature or high humidity environment may affect the measurement accuracy of the integrated front sensor. We suggest storing and using the monitor under the following conditions.
 - Temperature 30°C or less
 - Humidity 70% or less
- Avoid storing or using the sensor where it may be exposed to direct sunlight.

1-2. Package Contents

Check that all the following items are included in the packaging box. If any items are missing or damaged, contact your local EIZO representative.

Note

- Please keep the packaging box and materials for future movement or transport of the monitor.

- Monitor
- Power cord

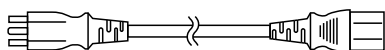

- Digital signal cable: DisplayPort - DisplayPort (PP300) × 2 pcs.

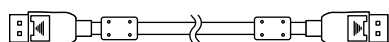

- Digital signal cable: DVI-D - DVI-D (Dual Link) (DD300DL) × 2 pcs.

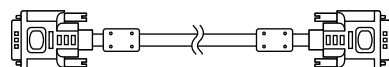

- USB cable : UU300

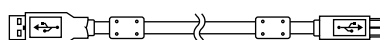

- AC adapter (PSA-073)
- Power cord holder
- EIZO LCD Utility Disk (CD-ROM)
- Instructions for Use (this manual)

1-3. EIZO LCD Utility Disk

An “EIZO LCD Utility Disk” (CD-ROM) is supplied with this product. The following table shows the disk contents and the overview of the software programs.

● Disk contents and software overview

The disk includes application software programs for adjustment, and Installation Manual. Refer to Readme.txt file on the disk for software startup procedures or file access procedures.

Contents	Overview
Readme.txt file	
RadiCS LE (for Windows)	Quality control software for calibrating the monitor and managing the calibration history.
ScreenManager Pro for Medical (for Windows)	Software for adjusting the screen using the mouse and keyboard.
Installation Manual of this monitor (PDF file)	
“Instructions for Use” of this monitor (PDF file)	

● Using RadiCS LE/ScreenManager Pro for Medical

For the installation and use of “RadiCS LE/ScreenManager Pro for Medical”, refer to the respective User’s Manual on the disk.

When using this software, you will need to connect a PC to the monitor with the supplied USB cable. For more information, refer to the Installation Manual (on the CD-ROM).

1-4. Controls and Functions

Monitor

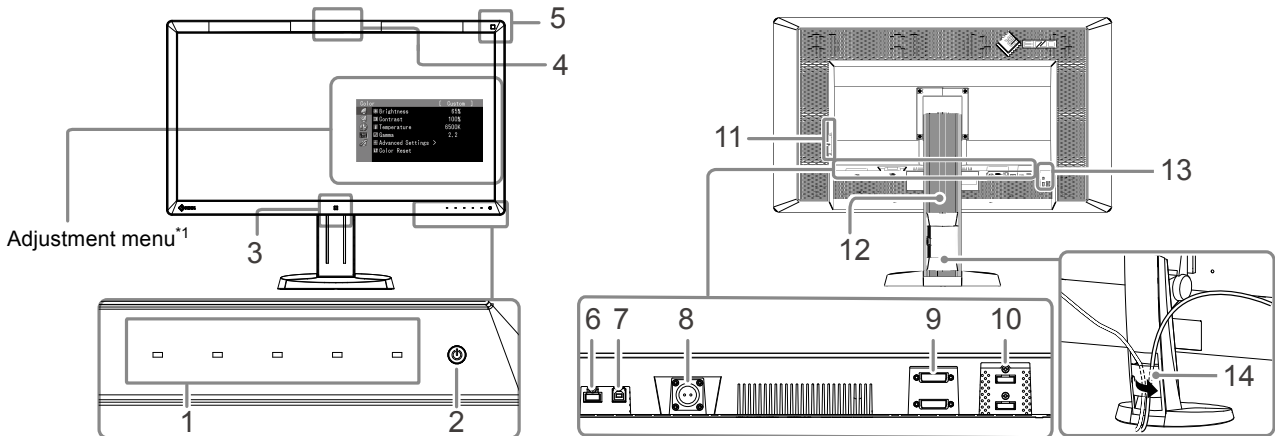

1. Operation switches	Displays the menu. Follow the guide to perform the desired operations.
2. ⏻ switch	<ul style="list-style-type: none"> • Turns the power on or off. • Indicates the monitor's operation status. Green: Operating, Orange: Power saving mode, Off: Main power/power off
3. Presence Sensor	Detects the movement of a person in front of the monitor.
4. Integrated Front Sensor (slide type)	Used for calibration and Grayscale Check.
5. Ambient Light Sensor	Measures the environmental illumination.
6. USB downstream port	Connects a peripheral USB device.
7. USB upstream port	Connects the USB cable to use the software that needs USB connection, or to use USB Hub function.
8. Power connector	Used to connect the AC adapter power cable.
9. Input signal connector	DVI-D connector
10. Input signal connector	DisplayPort connector
11. USB downstream port	Connects a peripheral USB device.
12. Stand	Used to adjust the height and angle of the monitor screen.
13. Security lock slot	Complies with Kensington's MicroSaver security system.
14. Cable holder	Covers the monitor cables.

*1 For instructions for use, refer to the Installation Manual (on the CD-ROM).

AC adapter (PSA-073)

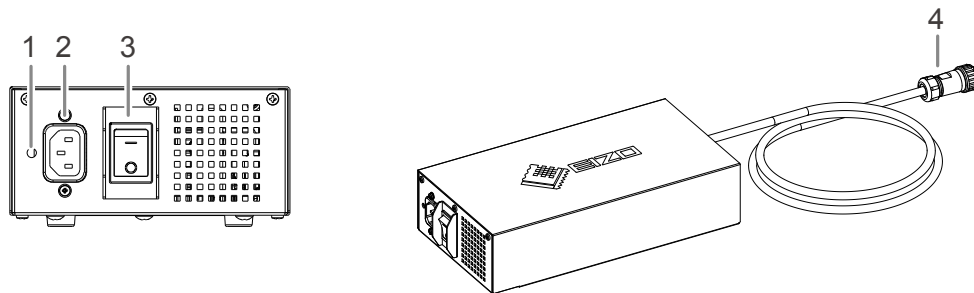

1. Power cord holder attachment hole	Used to attach the power cord holder.
2. Power connector	Connects the power cord.
3. Main power switch	Turns the main power on or off.
4. Power cable	Connects with the power connector on the monitor.

Chapter 2 Setting Up

2-1. Compatible Resolutions

The monitor supports the following resolutions.

√ : Supported

Resolution ^{*1}	Applicable signal	Dot Clock:	Vertical scan frequency	8M Pixel Mode		QFHD Mode	
				DVI	DisplayPort ^{*2}	DVI	DisplayPort ^{*2}
640×480	VGA	DVI: 310 MHz (Max.)	60 Hz	√	√	√	√
720×400	VGA TEXT		70 Hz	√	√	√	√
800×600	VESA		60 Hz	√	√	√	√
1024×768	VESA		60 Hz	√	√	√	√
1280×1024	VESA		60 Hz	√	√	√	√
1600×1200	VESA		60 Hz	√	√	√	√
1920×1200	VESA CVT RB		60 Hz	√	√	√	√
1920×1200	VESA CVT	DisplayPort: 290 MHz (Max.)	60 Hz	√	√	√	√
1920×2160	VESA CVT RB		36 Hz	-	-	√	-
1920×2160	VESA CVT RB		60 Hz	-	-	√	√
2048×2160	VESA CVT RB		30 Hz	√	-	-	-
2048×2160 ^{*3}	DP		60 Hz	-	√	-	-
2048×2160 ^{*3}	VESA CVT RB		60 Hz	√	-	-	-

*1 Compatible resolutions for the left and right screens.

*2 It is also appropriate for the 10 bit.

*3 Recommended resolution.

The graphics board should comply with the VESA standard.

2-2. Connecting Cables

Attention

- Check that the monitor and the PC are powered off.
- When replacing the current monitor with this monitor, be sure to change the PC settings for resolution and vertical scan frequency to those that are available for this monitor. Refer to the compatible resolution table before connecting the PC.

Note

- When connecting multiple PCs to this product, refer to the Installation Manual (on the CD-ROM).

1. Connect the signal cables to the input signal connectors and PC.

Check the shape of the connectors, and connect the cables.

After connecting the signal cable, tighten the screws of the connectors to secure the coupling.

Connection examples :

DisplayPort 1 - DisplayPort 2 / DisplayPort 1 - DVI 2 / DVI 1 - DisplayPort 2 / DVI 1 - DVI 2

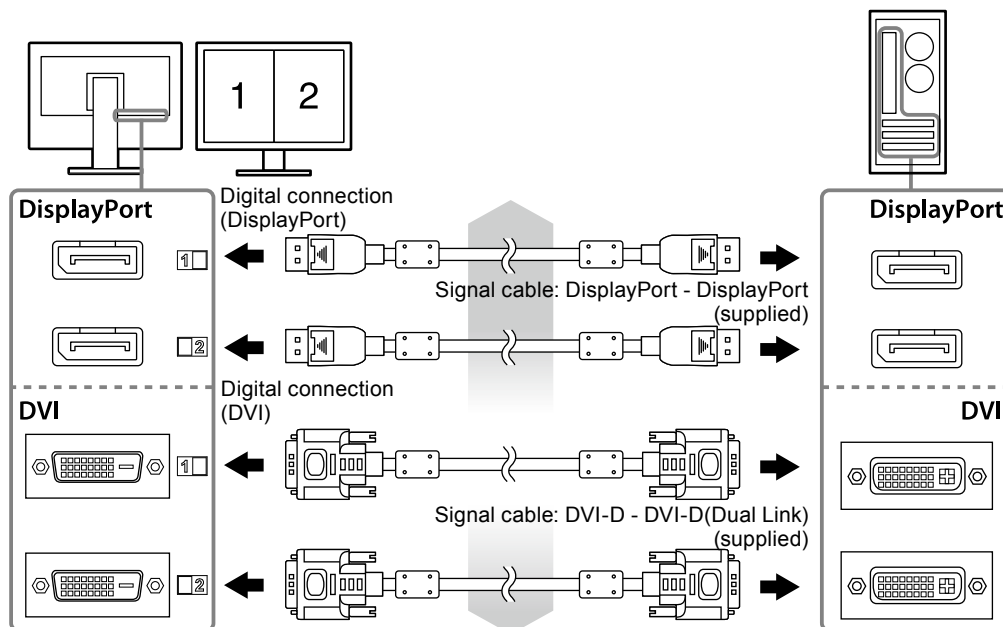

2. Connect the AC adapter power cable to the power connector on the monitor.

Attention

- Do not connect or disconnect the cable while the AC adapter main power is on.
- Do not install the AC adapter in the wrong orientation. The side with the EIZO logo should face up.

Check the shape of the monitor connector, and connect the power cable.

Tighten the screw for fixing the power cable to secure the power cable.

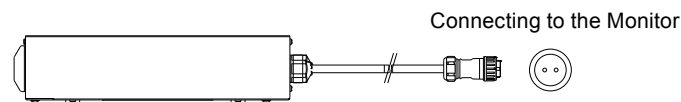

3. Attach the power cord holder (See “2-4. Attaching a Power Cord Holder” (page 16)).

4. Plug the power cord into a power outlet and the power connector on the AC adapter.

5. Turn on the AC adapter main power.

-: On, ○: Off

6. Connect the USB cable when using RadiCS LE or ScreenManager Pro for Medical.

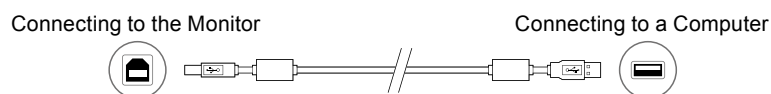

7. Touch to turn on the monitor.

The monitor's power indicator lights up green.

8. Turn on the PC.

The screen image appears.

If an image does not appear, refer to "Chapter 3 Troubleshooting" (page 17) for additional advice.

Attention

- Turn off the monitor and PC after using them.
- For the maximum power saving, it is recommended that the Power button be turned off. Turning off the AC adapter main power switch or unplugging the power cord completely shuts off power supply to the monitor.

Note

- In order to maximize the monitor life and to minimize luminance deterioration as well as power consumption, proceed the following:
 - Use the power saving function of the computer.
 - Turn off the monitor and PC after using them.

2-3. Adjusting the Screen Height and Angle

Hold left and right edge of the monitor with both hands, and adjust the screen height, tilt and swivel of the screen to the best condition for working.

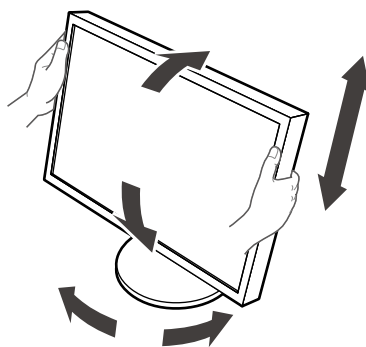

Attention

- Be sure that the cables are correctly connected.

2-4. Attaching a Power Cord Holder

Attach the power cord holder to prevent the power cord from falling off.

Attention

- Be sure to attach the power cord holder when the main power to the AC adapter is off or before the power cable is plugged into the power outlet.

1. Attach the supplied power cord holder to the power cord attachment hole on the AC adapter.

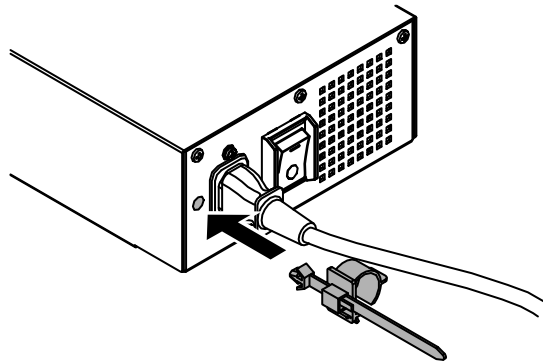

2. Adjust the position to secure the power cord holder referring to the figure shown below.

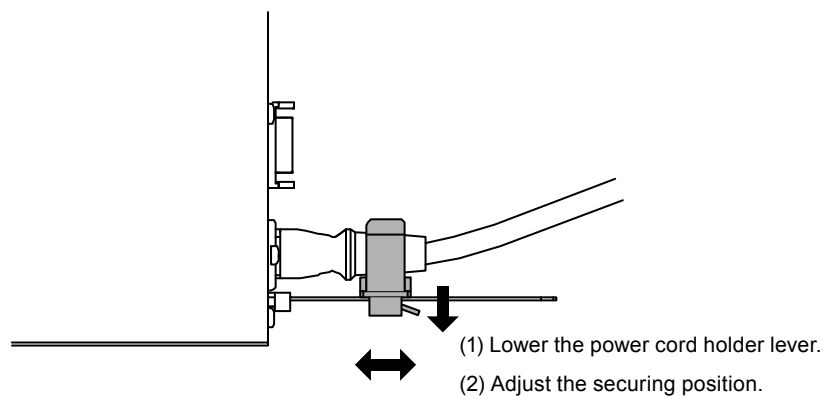

3. Secure the power cord holder to prevent the power cord from falling off.

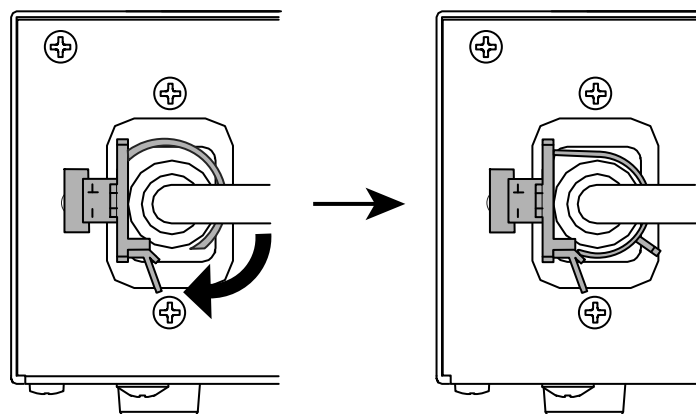

*Check that the power cord holder is secured.

Chapter 3 Troubleshooting

If a problem still remains after applying the suggested remedies, contact your local EIZO representative.

Problem	Possible cause and remedy
<p>1. No picture</p> <ul style="list-style-type: none"> • Power indicator does not light. <hr/> <ul style="list-style-type: none"> • Power indicator is lighting green. <hr/> <ul style="list-style-type: none"> • Power indicator is lighting orange. <hr/> <ul style="list-style-type: none"> • Power indicator is flashing orange and green. 	<ul style="list-style-type: none"> • Check whether the power cord and the adapter power cable are connected properly. • Turn the AC adapter main power switch on. • Touch . • Turn off the AC adapter main power, and then turn it on again a few minutes later. <hr/> <ul style="list-style-type: none"> • Increase "Brightness", "Contrast", or "Gain" in the Adjustment menu. • Turn off the AC adapter main power, and then turn it on again. <hr/> <ul style="list-style-type: none"> • Switch the input signal. For details, refer to the Installation Manual (on the CD-ROM). • Move the mouse or press any key on the keyboard. • Check whether the PC is turned on. • When Presence Sensor is set to "On", the monitor may have shifted to the power saving mode. Come near to the monitor. • Turn off the AC adapter main power, and then turn it on again. <hr/> <ul style="list-style-type: none"> • The device that is connected using DisplayPort have a problem. Solve the problem, turn off the monitor, and then turn it on again. Refer to the User's Manual of the output device for further details.
<p>2. The message below appears.</p> <ul style="list-style-type: none"> • This message appears when no signal is input. Example: <div data-bbox="268 1265 673 1713" style="background-color: black; color: white; padding: 10px; border: 1px solid black;"> <pre> No Signal Signal-1 DVI fH: 0.0 kHz fV: 0.0 Hz Signal-2 DP fH: 0.0 kHz fV: 0.0 Hz Check the input signal. </pre> </div>	<p>This message appears when the signal is not input correctly even when the monitor functions properly.</p> <hr/> <ul style="list-style-type: none"> • The message shown left may appear, because some PCs do not output the signal soon after power-on. • Check whether the PC is turned on. • Check whether the signal cable is connected properly. • Switch the input signal. For details, refer to the Installation Manual (on the CD-ROM).

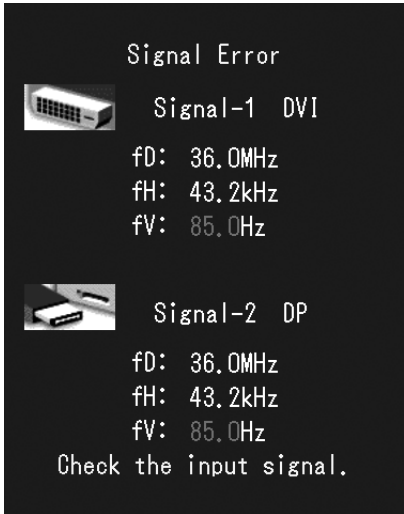
Problem	Possible cause and remedy
<ul style="list-style-type: none"> The message shows that the input signal is out of the specified frequency range. <p>Example:</p>  <p>fD: Dot clock fH: Horizontal scan frequency fV: Vertical scan frequency</p>	<ul style="list-style-type: none"> Check whether the PC is configured to meet the resolution and vertical scan frequency requirements of the monitor (see “2-1. Compatible Resolutions” (page 13)). Reboot the PC. Select an appropriate setting using the graphics board's utility. Refer to the manual of the graphics board for details.

Error code table

Error Code	Description
0***	<ul style="list-style-type: none"> Errors that occurred during SelfCalibration
1***	<ul style="list-style-type: none"> Errors that occurred during Grayscale Check
*1**	<ul style="list-style-type: none"> Errors that occurred during DICOM
*2**	<ul style="list-style-type: none"> Errors that occurred during Custom
*3**	<ul style="list-style-type: none"> Errors that occurred during CAL1
*4**	<ul style="list-style-type: none"> Errors that occurred during CAL2
*5**	<ul style="list-style-type: none"> Errors that occurred during CAL3
**10	<ul style="list-style-type: none"> The product maximum brightness may be lower than the target brightness. Lower the target brightness.
**11	<ul style="list-style-type: none"> The product minimum brightness may be higher than the target brightness. Raise the target brightness.
**34	<ul style="list-style-type: none"> The sensor may not have come out during calibration, or light may have entered the sensor. Turn off the AC adapter main power, wait for a few minutes before turning the power back on, and then execute SelfCalibration/Grayscale Check again.
**61	<ul style="list-style-type: none"> The sensor may not have come out. Check whether there is any foreign object near the sensor. Execute SelfCalibration/Grayscale Check again.
**94	<ul style="list-style-type: none"> SelfCalibration/Grayscale Check cannot be executed due to the following settings: <ul style="list-style-type: none"> - There is no signal input to the left screen, and the vertical resolution of the right screen is lower than 2160 dots. - The vertical resolutions of the left and right screens are lower than 2160 dots.
**95	<ul style="list-style-type: none"> The execution conditions for SelfCalibration/Grayscale Check may not be appropriate. Check the execution conditions and reset them if necessary.

Chapter 4 Specifications

LCD Panel	Type	RX850: IPS (Anti-Glare) RX850-AR: IPS (Anti-Reflection)	
	Backlight	LED	
	Size	79 cm (31.1 inch) (78.9 cm diagonal)	
	Native Resolution	4096 dots × 2160 lines	
	Display Size (H x V)	697.9 mm × 368.0 mm	
	Pixel Pitch	0.1704 mm	
	Display Colors	10-bit colors (DisplayPort) :	1.07 billion (maximum) colors of 68 billion colors
		8-bit colors (DVI) :	16.77 million from a palette of 68 billion colors
	Viewing Angles (H / V, typical)	178° / 178°	
	Recommended Brightness	500 cd/m ²	
Response Time (typical)	20 ms (Black-white-black)		
Video Signals	Input Terminals	DVI-D (Dual Link) × 2, DisplayPort × 2	
	Digital Scanning Frequency (H / V)	31 kHz - 140 kHz / 29Hz - 61Hz (DVI), 59 Hz - 61 Hz (DisplayPort) Frame synchronous mode: 29.5 Hz - 30.5 Hz, 59 Hz - 61 Hz	
USB	Port	Upstream port × 1, Downstream port × 2	
	Standard	USB Specification Revision 2.0	
Power	Input (AC Adapter)	AC 100 V - 120 V ±10 %, 50 / 60 Hz 2.3 A - 2.0 A AC 200 V - 240 V ±10 %, 50 / 60 Hz 1.2 A - 1.0 A	
	Input (Monitor)	DC24.5V 9A	
	Maximum Power Consumption	227 W or less	
	Power Save Mode	6.0 W or less (when only the DVI connector is connected, no USB device is connected, and "Input Selection" is set to "Manual", and "DC5V Output" is set to "Off")	
	Standby Mode	6.0 W or less (when only the DVI connector is connected, no USB device is connected, and "Input Selection" is set to "Manual", and "DC5V Output" is set to "Off")	
Physical Specifications	Dimensions	747 mm × 449.5 mm - 593.5 mm × 281.5 mm (W × H × D) (Tilt: 0°)	
	Dimensions (Monitor)	747 mm × 430 mm × 130 mm (W × H × D)	
	Dimensions (AC Adapter)	148 mm × 74 mm × 280 mm (W × H × D)	
	Net Weight	Approx. 19.8 kg	
	Net Weight (Monitor)	Approx. 15.8 kg	
	Net Weight (AC Adapter)	Approx. 2.6 kg	
	Height Adjustment Range	165 mm (Tilt: 25°), 144 mm (Tilt: 0°)	
	Tilt	Up 25°, down 0°	
	Swivel	344°	
Operating Environmental Requirements	Temperature:	0 °C to 35 °C (32 °F to 95 °F)	
	Humidity	20 % to 80 % R.H. (no condensation)	
	Air pressure	540 hPa to 1060 hPa	

Transportation/ Storage Environmental Requirements	Temperature	-20 °C to 60 °C (-4 °F to 140 °F)
	Humidity	10 % to 90 % R.H. (no condensation)
	Air pressure	200 hPa to 1060 hPa

Outside Dimensions

Unit: mm

Monitor

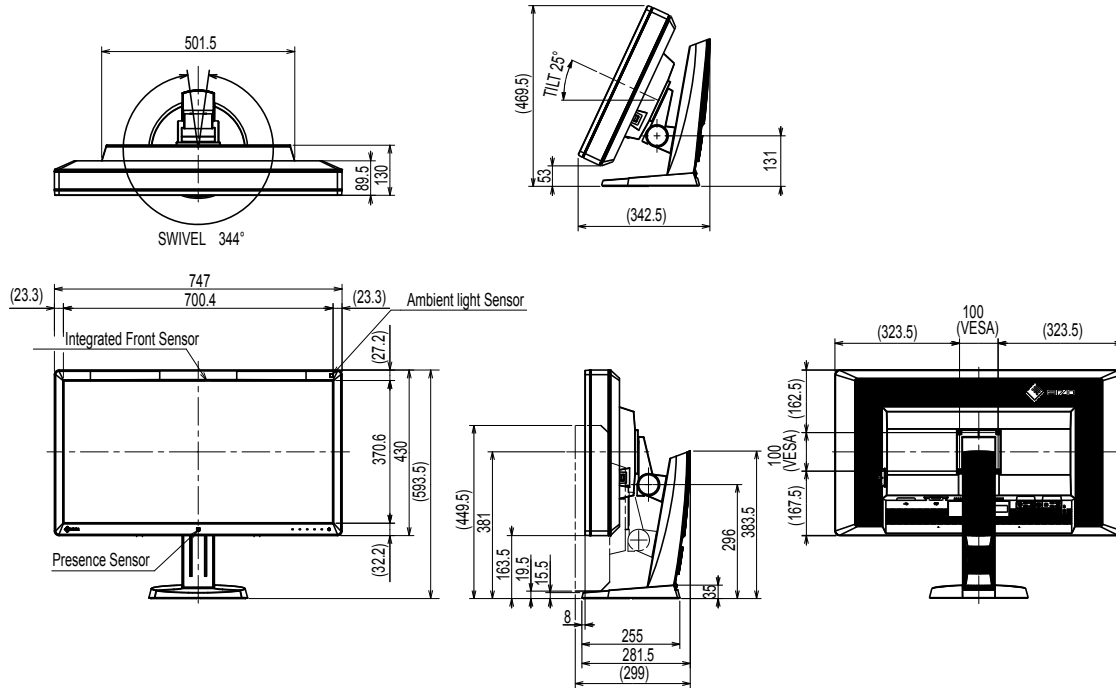

AC adapter (PSA-073)

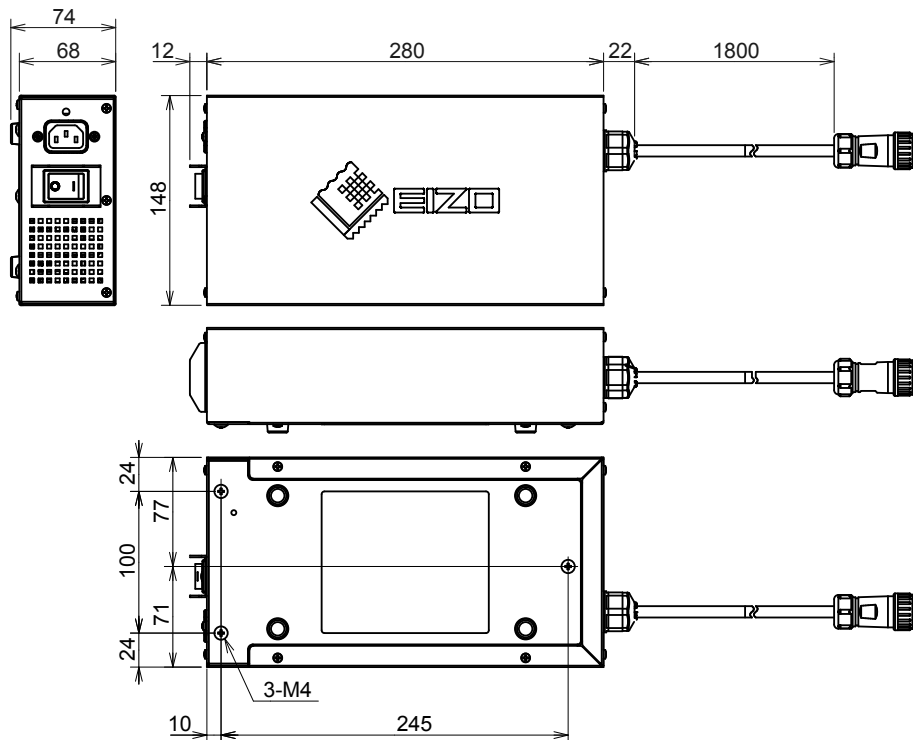

Accessories

Calibration Kit	EIZO "RadiCS UX1" Ver. 4.3.0 or later EIZO "RadiCS Version Up Kit" Ver. 4.3.0 or later
Network QC Management Software	EIZO "RadiNET Pro" Ver. 4.3.0 or later
Cleaning Kit	EIZO "ScreenCleaner"

For the latest information about the accessories and information about the latest compatible graphics board, refer to our web site.

<http://www.eizoglobal.com>

Chapter 5 Glossary

DDC (Display Data Channel)

VESA provides the standardization for the interactive communication of the setting information, etc. between a PC and the monitor.

DICOM (Digital Imaging and Communication in Medicine)

The DICOM standard was developed by the American College of Radiology and the National Electrical Manufacturer's Association of the USA.

The DICOM compatible device connection enables to transfer the medical image and information. The DICOM, Part 14 document defines the digital, grayscale medical image display.

DisplayPort

This is the interface standard for image signals standardized in accordance with VESA. It was developed with the aim of replacing the conventional DVI and analog interfaces, and it can transmit high resolution signals and sound signals, which DVI does not support. It also supports 10-bit color, copyright protection technology, long cables, etc. The standard size and mini size connectors have been standardized.

DVI (Digital Visual Interface)

DVI is a digital interface standard. DVI allows direct transmission of the PC's digital data without loss.

This adopts the TMDS transmission system and DVI connectors. There are two types of DVI connectors. One is a DVI-D connector for digital signal input only. The other is a DVI-I connector for both digital and analog signal inputs.

DVI DMPM (DVI Digital Monitor Power Management)

DVI DMPM is a digital interface power saving function. The "Monitor ON (operating mode)" and "Active Off (power saving mode)" are indispensable for DVI DMPM as the monitor's power mode.

Gain

This is used to adjust each color parameter for red, green and blue. An LCD monitor displays the color by the light passing through the panel color filter. Red, green and blue are the three primary colors. All the colors on the screen are displayed by combining these three colors. The color tone can be changed by adjusting the light intensity (volume) passing through each color's filter.

Gamma

Generally, the monitor brightness varies nonlinearly with the input signal level, which is called "Gamma Characteristic". A small gamma value produces a low-contrast image, while a large gamma value produces a highcontrast image.

HDCP (High-bandwidth Digital Content Protection)

Digital signal coding system developed to copy-protect the digital contents, such as video, music, etc.

This helps to transmit the digital contents safely by coding the digital contents sent via the DVI or HDMI connector on the output side and decoding them on the input side.

Any digital contents cannot be reproduced if both of the equipments on the output and input sides are not applicable to HDCP system.

Resolution

The LCD panel consists of numerous pixels of specified size, which are illuminated to form images. This monitor consists of horizontal 4096 pixels and 2160 vertical pixels. Therefore, if the combined resolution of the left and right screen is 4096×2160 , all pixels are illuminated as a full screen (1:1).

sRGB (Standard RGB)

International standard for color reproduction and color space among peripheral devices (such as monitors, printers, digital cameras, scanners). As a form of simple color matching for the Internet, colors can be displayed using tones close to those of the transmission and reception devices.

Temperature

Color temperature is a method to measure the white color tone, generally indicated in degrees Kelvin. The screen becomes reddish at a low temperature, and bluish at a high temperature, like the flame temperature.

5000 K: Slightly reddish white

6500 K: White referred to as daylight-balanced color

9300 K: Slightly bluish white

Appendix

Trademark

The terms HDMI and HDMI High-Definition Multimedia Interface, and the HDMI Logo are trademarks or registered trademarks of HDMI Licensing, LLC in the United States and other countries.

The DisplayPort Compliance Logo and VESA are registered trademarks of the Video Electronics Standards Association.

Acrobat, Adobe, Adobe AIR, and Photoshop are registered trademarks of Adobe Systems Incorporated in the United States and other countries.

AMD Athlon and AMD Opteron are trademarks of Advanced Micro Devices, Inc.

Apple, ColorSync, eMac, iBook, iMac, iPad, Mac, MacBook, Macintosh, Mac OS, PowerBook, and QuickTime are registered trademarks of Apple Inc.

ColorMunki, Eye-One, and X-Rite are registered trademarks or trademarks of X-Rite Incorporated in the United States and/or other countries.

ColorVision and ColorVision Spyder2 are registered trademarks of DataColor Holding AG in the United States.

Spyder3 and Spyder4 are trademarks of DataColor Holding AG.

ENERGY STAR is a registered trademark of the United States Environmental Protection Agency in the United States and other countries.

GRACoL and IDEAlliance are registered trademarks of International Digital Enterprise Alliance.

NEC is a registered trademark of NEC Corporation.

PC-9801 and PC-9821 are trademarks of NEC Corporation.

NextWindow is a registered trademark of NextWindow Ltd.

Intel, Intel Core and Pentium are registered trademarks of Intel Corporation in the United States and other countries.

PowerPC is a registered trademark of International Business Machines Corporation.

PlayStation is a registered trademark of Sony Computer Entertainment Inc.

PSP and PS3 are trademarks of Sony Computer Entertainment Inc.

RealPlayer is a registered trademark of RealNetworks, Inc.

TouchWare is a trademark of 3M Touch Systems, Inc.

Windows, Windows Media, Windows Vista, SQL Server, and Xbox 360 are registered trademarks of Microsoft Corporation in the United States and other countries.

YouTube is a registered trademark of Google Inc.

Firefox is a registered trademark of the Mozilla Foundation.

Kensington and MicroSaver are trademarks of ACCO Brands Corporation.

EIZO, the EIZO Logo, ColorEdge, DuraVision, FlexScan, FORIS, RadiCS, RadiForce, RadiNET, Raptor, and ScreenManager are registered trademarks of EIZO Corporation in Japan and other countries.

ColorNavigator, EcoView NET, EIZO EasyPIX, EIZO ScreenSlicer, i•Sound, Screen Administrator, and UniColor Pro are trademarks of EIZO Corporation.

All other company and product names are trademarks or registered trademarks of their respective owners.

License

The bitmap font used for this product is designed by Ricoh Industrial Solutions Inc.

Medical Standard

- It shall be assured that the final system is in compliance to IEC60601-1-1 requirement.
- Power supplied equipment can emit electromagnetic waves, that could influence, limit or result in malfunction of the monitor. Install the equipment in a controlled environment, where such effects are avoided.

Classification of Equipment

- Type of protection against electric shock : Class I
- EMC class: EN60601-1-2:2015 Group 1 Class B
- Classification of medical device (MDD 93/42/EEC) : Class I
- Mode of operation : Continuous
- IP Class : IPX0

EMC Information

The RadiForce series has a performance that appropriately displays images.

Environments of Intended Use

The RadiForce series is intended to be used in Professional healthcare facility environments such as clinics and hospitals.

The following environments are not suitable for the RadiForce series to be used:

- Home healthcare environments
- In the vicinity of high-frequency surgical equipments such as electrosurgical knives
- In the vicinity of short-wave therapy equipments
- RF shielded room of the medical equipment systems for MRI
- In shielded location Special environments
- Installed in vehicles including ambulances.
- Other special environment

WARNING

The RadiForce series requires special precautions regarding EMC and need to be installed. You need to carefully read EMC Information and the “PRECAUTIONS” section in this document, and observe the following instructions when installing and operating the product.

The RadiForce series should not be used adjacent to or stacked with other equipment. If adjacent or stacked use is necessary, the equipment or system should be observed to verify normal operation in the configuration in which it will be used.

When using a portable RF communication equipment, keep it 30 cm (12 inches) or more away from any part, including cables, of the RadiForce series. Otherwise, degradation of the performance of this equipment could result.

Anyone who connects additional equipment to the signal input part or signal output parts, configuring a medical system, is responsible that the system complies with the requirements of IEC/EN60601-1-2.

Be sure to use the cables attached to the product, or cables specified by EIZO.

Use of cables other than those specified or provided by EIZO of this equipment could result in increased electromagnetic emissions or decreased electromagnetic immunity of this equipment and improper operation.

Cables	EIZO Designated Cables	Max. Cable Length	Shielding	Ferrite Core
Signal cable (DisplayPort)	PP300 / PP200	3 m	Shielded	With Ferrite Cores
Signal cable (DVI-D)	DD300DL / DD200DL	3 m	Shielded	With Ferrite Cores
USB cable	UU300 / MD-C93	3 m	Shielded	With Ferrite Cores
DC Cord	-	1,9 m	Unshielded	Without Ferrite Cores
AC Cord (with earth)	-	3 m	Unshielded	Without Ferrite Cores

Technical Descriptions

Electromagnetic emissions		
The RadiForce series is intended for use in the electromagnetic environment specified below. The customer or the user of the RadiForce series should assure that it is used in such an environment.		
Emission test	Compliance	Electromagnetic environment - Guidance
RF emissions CISPR11 / EN55011	Group 1	The RadiForce series uses RF energy only for its internal function. Therefore, its RF emission are very low and are not likely to cause any interference in nearby electronic equipment.
RF emissions CISPR11 / EN55011	Class B	The RadiForce series is suitable for use in all establishments, including domestic establishments and those directly connected to the public low-voltage power supply network that supplies buildings used for domestic purposes.
Harmonic emissions IEC / EN61000-3-2	Class D	
Voltage fluctuations / flicker emissions IEC / EN61000-3-3	Complies	

Electromagnetic immunity			
The RadiForce series has been tested at the following compliance levels according to the testing requirements for professional healthcare facility environments defined in IEC / EN60601-1-2. Customers and users of the RadiForce series must ensure that the RadiForce series is used in the following environments:			
Immunity test	Test level for professional healthcare facility environments	Compliance level	Electromagnetic environment - Guidance
Electrostatic discharge (ESD) IEC / EN61000-4-2	±8 kV contact discharge ±15 kV air discharge	±8 kV contact discharge ±15 kV air discharge	Floors should be wood, concrete or ceramic tile. If floors are covered with synthetic material, the relative humidity should be at least 30%.
Electrical fast transients / bursts IEC / EN61000-4-4	±2 kV power lines ±1 kV input / output lines	±2 kV power lines ±1 kV input / output lines	Mains power quality should be that of a typical commercial or hospital environment.
Surges IEC / EN61000-4-5	±1 kV line to line ±2 kV line to ground	±1 kV line to line ±2 kV line to ground	Mains power quality should be that of a typical commercial or hospital environment.
Voltage dips, short interruptions and voltage variations on power supply input lines IEC / EN61000-4-11	0 % U_T (100 % dip in U_T) 0.5 cycles and 1 cycle 70 % U_T (30 % dip in U_T) 25 cycles 0 % U_T (100 % dip in U_T) 5 sec	0 % U_T (100 % dip in U_T) 0.5 cycles and 1 cycle 70 % U_T (30 % dip in U_T) 25 cycles 0 % U_T (100 % dip in U_T) 5 sec	Mains power quality should be that of a typical commercial or hospital environment. If the user of the RadiForce series requires continued operation during power mains interruptions, it is recommended that the RadiForce series be powered from an uninterruptible power supply or a battery.
Power frequency magnetic fields IEC / EN61000-4-8	30 A/m (50 / 60 Hz)	30 A/m	Power frequency magnetic fields should be at levels characteristic of a typical location in a typical commercial or hospital environment. The product should be kept at least 15 cm away from the source of power frequency magnetic fields during use.

Immunity test		Test level for professional healthcare facility environments	Compliance level	Electromagnetic environment - Guidance
<p>The RadiForce series has been tested at the following compliance levels according to the testing requirements for professional healthcare facility environments defined in IEC / EN60601-1-2.</p> <p>Customers and users of the RadiForce series must ensure that the RadiForce series is used in the following environments:</p>				
Conducted disturbances induced by RF fields IEC / EN61000-4-6		3 Vrms 150 kHz - 80 MHz	3 Vrms	Portable and mobile RF communications equipment should be used no closer to any part of the RadiForce series, including cables, than the recommended separation distance calculated from the equation applicable to the frequency of the transmitter. Recommended separation distance $d = 1.2\sqrt{P}$
Radiated RF fields IEC / EN61000-4-3		6 Vrms ISM bands between 150 kHz and 80 MHz 3 V/m 80 MHz - 2.7 GHz	6 Vrms 3 V/m	
<p>Where "P" is the maximum output power rating of the transmitter in watts (W) according to the transmitter manufacturer and "d" is the recommended separation distance in meters (m).</p> <p>Field strengths from fixed RF transmitters, as determined by an electromagnetic site survey ^{a)}, should be less than the compliance level in each frequency range ^{b)}.</p> <p>Interference may occur in the vicinity of equipment marked with the following symbol.</p> 				
Note 1	U _T is the a.c. mains voltage prior to application of the test level.			
Note 2	At 80 MHz and 800 MHz, the higher frequency range applies.			
Note 3	Guidelines regarding conducted disturbances induced by RF fields or radiated RF fields may not apply in all situations. Electromagnetic propagation is affected by absorption and reflection from structures, objects and people.			
Note 4	The ISM bands between 150 kHz and 80 MHz are 6.765 MHz to 6.795 MHz, 13.553 MHz to 13.567 MHz, 26.957 MHz to 27.283 MHz, and 40.66 MHz to 40.70 MHz.			
a)	Field strengths from fixed transmitters, such as base stations for radio (cellular/cordless) telephones and land mobile radios, amateur radio, AM and FM radio broadcast and TV broadcast cannot be predicted theoretically with accuracy. To assess the electromagnetic environment due to fixed RF transmitters, an electromagnetic site survey should be considered. If the measured field strength in the location in which the RadiForce series is used exceeds the applicable RF compliance level above, the RadiForce series should be observed to verify normal operation. If abnormal performance is observed, additional measures may be necessary, such as reorienting or relocating the RadiForce series.			
b)	Over the frequency range 150 kHz to 80 MHz, field strengths should be less than 3 V/m.			

Recommended separation distances between portable or mobile RF communication equipment and the RadiForce Series

The RadiForce series is intended for use in an electromagnetic environment in which radiated RF disturbances are controlled. The customer or the user of the RadiForce series can help prevent electromagnetic interference by maintaining a minimum distance between portable and mobile RF communications equipment (transmitters) and the RadiForce series.

Immunity to proximity fields from following RF wireless communication equipments has been confirmed:

Test frequency (MHz)	Bandwidth ^{a)} (MHz)	Service ^{a)}	Modulation ^{b)}	Maximum power (W)	Minimum separation distance (m)	IEC / EN60601 test level (V/m)	Compliance level (V/m)
385	380 - 390	TETRA 400	Pulse modulation ^{b)} 18 Hz	1.8	0.3	27	27
450	430 - 470	GMRS 460, FRS 460	FM ±5 kHz deviation 1 kHz sine	2	0.3	28	28
710 745 780	704 - 787	LTE Band 13, 17	Pulse modulation ^{b)} 217 Hz	0.2	0.3	9	9
810 870 930	800 - 960	GSM 800 / 900, TETRA 800, iDEN 820 CDMA 850, LTE Band 5	Pulse modulation ^{b)} 18 Hz	2	0.3	28	28
1720 1845 1970	1700 - 1990	GSM 1800; CDMA 1900; GSM 1900; DECT; LTE Band 1, 3, 4, 25; UMTS	Pulse modulation ^{b)} 217 Hz	2	0.3	28	28
2450	2400 - 2570	Bluetooth, WLAN, 802.11 b/g/n, RFID 2450, LTE Band 7	Pulse modulation ^{b)} 217 Hz	2	0.3	28	28
5240 5500 5785	5100 - 5800	WLAN 802.11 a/n	Pulse modulation ^{b)} 217 Hz	0.2	0.3	9	9
a)	For some services, only the uplink frequencies are included.						
b)	Carrier waves are modulated using a 50 % duty cycle square wave signal.						

The RadiForce series is intended for use in an electromagnetic environment in which radiated RF disturbances are controlled. For other portable and mobile RF communication equipments (transmitters), minimum distance between portable and mobile RF communications equipment (transmitters) and the RadiForce series as recommended below, according to the maximum output power of the communications equipment.

Rated maximum output power of transmitter (W)	Separation distance according to frequency of transmitter (m)		
	150 kHz to 80 MHz $d = 1.2\sqrt{P}$	80 MHz to 800 MHz $d = 1.2\sqrt{P}$	800 MHz to 2.7 GHz $d = 2.3\sqrt{P}$
0.01	0.12	0.12	0.23
0.1	0.38	0.38	0.73
1	1.2	1.2	2.3
10	3.8	3.8	7.3
100	12	12	23

For transmitters rated at a maximum output power not listed above, the recommended separation distance “d” in meters (m) can be estimated using the equation applicable to the frequency of the transmitter, where “P” is the maximum output power rating of the transmitter in watts (W) according to the transmitter manufacturer.

Note 1	At 80 MHz and 800 MHz, the separation distance for a higher frequency range applies.
Note 2	These guidelines may not apply in all situations. Electromagnetic propagation is affected by absorption and reflection from structures, objects and people.

FCC Declaration of Conformity

For U.S.A. , Canada, etc. (rated 100-120 Vac) Only

FCC Declaration of Conformity

We, the Responsible Party

EIZO Inc.

5710 Warland Drive, Cypress, CA 90630

Phone: (562) 431-5011

declare that the product

Trade name: EIZO

Model: RadiForce RX850

is in conformity with Part 15 of the FCC Rules. Operation of this product is subject to the following two conditions: (1) this device may not cause harmful interference, and (2) this device must accept any interference received, including interference that may cause undesired operation.

This equipment has been tested and found to comply with the limits for a Class B digital device, pursuant to Part 15 of the FCC Rules. These limits are designed to provide reasonable protection against harmful interference in a residential installation. This equipment generates, uses, and can radiate radio frequency energy and, if not installed and used in accordance with the instructions, may cause harmful interference to radio communications. However, there is no guarantee that interference will not occur in a particular installation. If this equipment does cause harmful interference to radio or television reception, which can be determined by turning the equipment off and on, the user is encouraged to try to correct the interference by one or more of the following measures.

- * Reorient or relocate the receiving antenna.
- * Increase the separation between the equipment and receiver.
- * Connect the equipment into an outlet on a circuit different from that to which the receiver is connected.
- * Consult the dealer or an experienced radio/TV technician for help.

Changes or modifications not expressly approved by the party responsible for compliance could void the user's authority to operate the equipment.

Note

Use the attached specified cable below or EIZO signal cable with this monitor so as to keep interference within the limits of a Class B digital device.

- AC Cord
- Shielded Signal Cable (enclosed)

Canadian Notice

This Class B digital apparatus complies with Canadian ICES-003.
Cet appareil numérique de la classe B est conforme à la norme NMB-003 du Canada.



EIZO Corporation

153 Shimokashiwano, Hakusan, Ishikawa 924-8566 Japan

艺卓显像技术(苏州)有限公司

中国苏州市苏州工业园区展业路 8 号中新科技工业坊 5B

EC REP



EIZO GmbH

Carl-Benz-Straße 3, 76761 Rülzheim, Germany

<http://www.eizoglobal.com>

Copyright © 2014-2019 EIZO Corporation. All rights reserved.



00N0L853E1 
IFU-RX850-4 

5th Edition-May, 2019 Printed in Japan.