

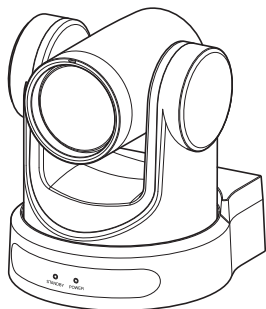

4K PTZ REMOTE CAMERA

KY-PZ400NWU/KY-PZ400NWE KY-PZ400NBU/KY-PZ400NBE

INSTRUCTIONS (Installation/IP Address Settings)



Specifications and appearance of this unit are subject to change for further improvement without prior notice.

Details

For details on settings and operation, refer to “INSTRUCTIONS” on the website. Please check the latest INSTRUCTIONS, tools, etc. from the URL below.

North America:

<http://pro.jvc.com/prof/main.jsp>

Europe:

<http://www.service.jvcpro.eu/public/>

For Customer Use:

Enter below the Serial No. which is located on the body.

Retain this information for future reference.

Model No. KY-PZ400NWU/KY-PZ400NBU

Serial No. _____

Please read the following before getting started:

Thank you for purchasing this JVC product. Before operating this unit, please read the instructions carefully to ensure the best possible performance.

In this manual, each model number is described without the last letter (U/E) which means the shipping destination. (U: for USA and Canada, E: for Europe) Only “U” models (KY-PZ400NWU/KY-PZ400NBU) have been evaluated by UL.

FOR USA

These are general Important Safety Instructions and certain items may not apply to all appliances.

Important Safety Instructions

1. Read these instructions.
2. Keep these instructions.
3. Heed all warnings.
4. Follow all instructions.
5. Do not use this apparatus near water.
6. Clean only with dry cloth.
7. Do not block any ventilation openings. Install in accordance with the manufacturer's instructions.
8. Do not install near any heat sources such as radiators, heat registers, stoves, or other apparatus (including amplifiers) that produce heat.
9. Protect the power cord from being walked on or pinched particularly at plugs, convenience receptacles, and the point where they exit from the apparatus.
10. Only use attachments/accessories specified by the manufacturer.
11. Use only with the cart, stand, tripod, bracket, or table specified by the manufacturer, or sold with the apparatus.
When a cart is used, use caution when moving the cart/apparatus combination to avoid injury from tip-over.
12. Unplug this apparatus during lightning storms or when unused for long periods of time.
13. Refer all servicing to qualified service personnel.
Servicing is required when the apparatus has been damaged in any way, such as power-supply cord or plug is damaged, liquid has been spilled or objects have fallen into the apparatus, the apparatus has been exposed to rain or moisture, does not operate normally, or has been dropped.

**For USA-California Only**

This product contains a CR Coin Cell Lithium Battery which contains Perchlorate Material – special handling may apply.

See www.dtsc.ca.gov/hazardouswaste/perchlorate

POUR LES ÉTATS-UNIS

Ces informations sont des **CONSIGNES DE SÉCURITÉ IMPORTANTES** et certains points peuvent ne pas s'appliquer à tous les appareils.

CONSIGNES DE SÉCURITÉ IMPORTANTES

1. Lire ces instructions.
2. Conserver ces instructions.
3. Tenir compte de tous les avertissements.
4. Respecter toutes les instructions.
5. Ne pas utiliser cet appareil à proximité de l'eau.
6. Ne nettoyer qu'avec un chiffon sec.
7. Ne pas boucher les ouvertures de ventilation.
Installer selon les instructions du fabricant.
8. Ne pas installer à proximité de sources de chaleur telles que des radiateurs, des accumulateurs de chaleur, des poêles, ou d'autres appareils (comprenant les amplificateurs) qui produisent de la chaleur.
9. Protéger le cordon d'alimentation pour éviter qu'il ne soit piétiné ou ne se coince, tout particulièrement au niveau de la fiche, de la prise de courant et du point où il sort de l'appareil.
10. Utiliser uniquement des équipements/accessoires spécifiés par le fabricant.
11. N'utiliser qu'avec le chariot, le stand, le trépied, le support ou la table spécifié par le fabricant, ou vendu avec l'appareil.
Lorsqu'un chariot est utilisé, faire attention pour déplacer la combinaison chariot/appareil pour éviter des blessures causées par un basculement.
12. Débrancher cet appareil pendant un orage ou quand il n'est pas utilisé pendant une longue durée.
13. L'entretien ou la réparation de l'appareil doit être effectué par du personnel qualifié uniquement.
Un dépannage est nécessaire lorsque l'appareil a été endommagé d'une façon ou d'une autre, telle que lorsque le cordon d'alimentation ou la fiche est endommagé, si du liquide a été renversé ou si des objets sont tombés à l'intérieur de l'appareil, si l'appareil a été exposé à la pluie ou à l'humidité, ne fonctionne pas normalement ou a fait une chute.



Pour Californie des États-Unis seulement

Cet appareil contient une pile-bouton CR au lithium qui contient du perchlorate – une manipulation spéciale peut être requise.

Voir www.dtsc.ca.gov/hazardouswaste/perchlorate

Safety Precautions

FOR USA AND CANADA



CAUTION

RISK OF ELECTRIC SHOCK
DO NOT OPEN



CAUTION:
TO REDUCE THE RISK OF ELECTRIC SHOCK. DO NOT REMOVE COVER (OR BACK). NO USER-SERVICEABLE PARTS INSIDE. REFER SERVICING TO QUALIFIED SERVICE PERSONNEL.



The lightning flash with arrowhead symbol, within an equilateral triangle is intended to alert the user to the presence of uninsulated “dangerous voltage” within the product’s enclosure that may be of sufficient magnitude to constitute a risk of electric shock to persons.



The exclamation point within an equilateral triangle is intended to alert the user to the presence of important operating and maintenance (servicing) instructions in the literature accompanying the appliance.

POUR CANADA

ATTENTION



RISQUE D'ELECTROCUTION
NE PAS OUVRIR



ATTENTION:
POUR EVITER TOUT RISQUE D'ELECTROCUTION NE PAS OUVRIR LE BOITIER. AUCUNE PIECE INTERIEURE N'EST A REGLER PAR L'UTILISATEUR. SE REFERER A UN AGENT QUALIFIE EN CAS DE PROBLEME.



Le symbole de l'éclair à l'intérieur d'un triangle équilatéral est destiné à alerter l'utilisateur sur la présence d'une “tension dangereuse” non isolée dans le boîtier du produit. Cette tension est suffisante pour provoquer l'électrocution de personnes.



Le point d'exclamation à l'intérieur d'un triangle équilatéral est destiné à alerter l'utilisateur sur la présence d'opérations d'entretien importantes au sujet desquelles des renseignements se trouvent dans le manuel d'instructions.

Ces symboles ne sont utilisés qu'aux Etats-Unis.

Supplier's Declaration of Conformity

Model Number: KY-PZ400NWU
KY-PZ400NBU

Trade Name: JVC

Responsible party: JVCCKENWOOD USA Corporation

Address: 500 Valley Road,
Suite 203 Wayne,
NJ 07470

Telephone Number: 973-317-5000

This device complies with Part 15 of the FCC Rules. Operation is subject to the following two conditions: (1) This device may not cause harmful interference, and (2) this device must accept any interference received, including interference that may cause undesired operation.

Changes or modifications not approved by JVC could void the user's authority to operate the equipment. This equipment has been tested and found to comply with the limits for a Class A digital device, pursuant to Part 15 of the FCC Rules. These limits are designed to provide reasonable protection against harmful interference when the equipment is operated in a commercial environment.

This equipment generates, uses, and can radiate radio frequency energy and, if not installed and used in accordance with the instructions, may cause harmful interference to radio communications. Operation of this equipment in a residential area is likely to cause harmful interference in which case the user will be required to correct the interference at his own expense.

Déclaration de conformité du fournisseur

Numéro de modèle : KY-PZ400NWU
KY-PZ400NBU

Nom de marque : JVC

Personne responsable : JVCCKENWOOD USA Corporation

Adresse : 500 Valley Road,
Suite 203 Wayne,
NJ 07470

Numéro de téléphone : 973-317-5000

Cet ensemble se conforme à la partie 15 des règles de la FCC (Federal Communications Commission). Le fonctionnement est sujet aux deux conditions suivantes : (1) Cet appareil ne peut pas causer d'interférences nuisibles, et (2) cet appareil doit accepter toute interférence reçue, comprenant des interférences qui peuvent causer un mauvais fonctionnement.

Des changements ou modifications non approuvés par JVC peuvent annuler le droit de l'utilisateur de faire fonctionner l'appareil. Cet appareil a été testé et il a été reconnu qu'il se conforme aux limites concernant l'appareillage informatique de classe A correspondant à la partie 15 des règles de la FCC. Ces limites sont conçues pour fournir une protection raisonnable contre les interférences dangereuses lorsque l'équipement est utilisé dans un environnement commercial.

Cet appareil génère, utilise et peut émettre de l'énergie des fréquences radio et, s'il n'est pas installé et utilisé selon les instructions du fabricant, peut causer des interférences nuisibles en communications radio. L'utilisation de cet équipement dans une zone résidentielle est susceptible de causer des interférences néfastes, auquel cas l'utilisateur devra prendre des mesures à ses propres frais.

CAUTION:

The mains plug shall remain readily operable.

- Remove the mains plug immediately if the camera functions abnormally.

WARNING:

The battery pack, the camera with battery installed, and the remote control with battery installed should not be exposed to excessive heat such as direct sunlight, fire or the like.

WARNING: TO PREVENT FIRE OR SHOCK HAZARD, DO NOT EXPOSE THIS UNIT TO RAIN OR MOISTURE.

NOTES:

- The rating plate and safety caution are on the bottom and/or the back of the main unit.
- The serial number plate is on the bottom of the unit.
- The rating information and safety caution of the AC adapter are on its upper and lower sides.

Caution on Replaceable lithium battery

The battery used in this device may present a fire or chemical burn hazard if mistreated.

Do not recharge, disassemble, heat above 100°C (212°F) or incinerate.

Replace battery with Panasonic, Sanyo, Sony or Maxell CR2025.

Danger of explosion or risk of fire if the battery is incorrectly replaced.

- Dispose of used battery promptly.
- Keep away from children.
- Do not disassemble and do not dispose of in fire.

Attention:

La prise secteur doit être opérationnelle.

- Débranchez immédiatement la fiche secteur si le caméscope ne fonctionne pas normalement.

Avertissement:

Évitez d'exposer la batterie, le caméscope avec la batterie insérée ou la télécommande avec la batterie insérée à une chaleur excessive, telle que celle des rayons directs du soleil, d'un feu ou de tout autre source de chaleur.

AVERTISSEMENT : POUR EVITER LES RISQUES D'INCENDIE OU D'ELECTROCUTION, NE PAS EXPOSER L'APPAREIL A LA PLUIE NI A L'HUMIDITE.

REMARQUES :

- La plaque d'identification et l'avertissement de sécurité se trouvent sous l'appareil et/ou au dos.
- La plaque du numéro de série est située sur la partie inférieure de l'appareil.
- Les informations d'identification et l'avertissement de sécurité de l'adaptateur secteur sont situés sur ses côtés supérieur et inférieur.

Avertissement sur la pile au lithium remplaçable

La pile utilisée dans cet appareil peut présenter des risques d'incendie ou de brûlure chimique si elle est mal traitée.

Ne pas recharger, démonter, chauffer à plus de 100°C (212°F) ni mettre au feu.

Remplacez la pile avec Panasonic, Sanyo, Sony ou Maxell CR2025.

Danger d'explosion ou risque d'incendie si la pile n'est pas changée correctement.

- Jeter immédiatement les piles usées.
- Placer hors de la portée des enfants.
- Ne pas démonter ni jeter au feu.

When the equipment is installed in a cabinet or on a shelf, make sure that it has sufficient space on all sides to allow for ventilation (10 cm (3-15/16") or more on both sides, on top and at the rear). Do not block the ventilation holes. (If the ventilation holes are blocked by a newspaper, or cloth etc. the heat may not be able to get out.) No naked flame sources, such as lighted candles, should be placed on the apparatus. When discarding batteries, environmental problems must be considered and the local rules or laws governing the disposal of these batteries must be followed strictly.

The apparatus shall not be exposed to dripping or splashing and that no objects filled with liquids, such as vases, shall be placed on the apparatus.

Do not point the lens directly into the sun. This can cause eye injuries, as well as lead to the malfunctioning of internal circuitry. There is also a risk of fire or electric shock.

CAUTION!

Connecting cables (Audio/Video, etc.) to this unit and leaving it on top of the TV is not recommended, as tripping on the cables will cause the unit to fall, resulting in damage.

Si le matériel est installé dans un coffret ou sur une étagère, s'assurer qu'il y a un espace suffisant sur tous les côtés pour permettre la ventilation (10 cm (3-15/16") ou plus sur les deux côtés, au dessus et à l'arrière).

Ne pas boucher les orifices de ventilation.

(Si les orifices de ventilation sont bouchés par un journal, un tissu, etc., la chaleur peut ne pas s'éliminer.)

Aucune source à flamme nue, telle que des bougies allumées, ne doit être placée sur l'appareil.

En jetant des batteries aux ordures, les problèmes d'environnement doivent être pris en considération et les réglementations locales ou la législation concernant le rebut de ces batteries doivent être strictement respectées.

L'appareil ne doit pas être exposé à de l'eau ou à des éclaboussures et les objets remplis de liquide, tels que des vases, ne doivent pas être placés sur l'appareil.

Ne dirigez pas l'objectif directement vers le soleil. Vous pourriez vous abîmer la vue et l'appareil pourrait être endommagé. Il y a aussi risque d'incendie ou d'électrocution.

Attention!

Avec des câbles (Audio/Vidéo, etc.) raccordés, il est recommandé de ne pas laisser le caméscope sur le dessus du téléviseur, car tirer sur les câbles pourrait faire tomber le caméscope, causant des dommages.

When using the AC adapter in areas other than the USA

The provided AC adapter features automatic voltage selection in the AC range from 110 V to 240 V.

USING HOUSEHOLD AC PLUG ADAPTER

In case of connecting the unit's power cord to an AC wall outlet other than American National Standard C73 series type, use an AC plug adapter called a "Siemens Plug" as shown.

For this AC plug adapter, please contact the local dealers in your area.

Plug Adapter

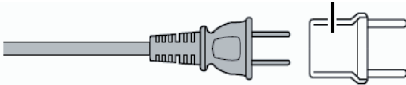

- Remove the AC adapter from the AC wall outlet when not in use.
- Do not leave dust or metal objects adhered to the AC wall outlet or AC adapter (power/DC plug).

Lorsque vous utilisez l'adaptateur secteur ailleurs qu'aux États-Unis

L'adaptateur secteur fourni dispose d'une sélection de tension automatique dans la plage CA de 110 V à 240 V.

UTILISATION D'UN ADAPTEUR SECTEUR DE PRISE DOMESTIQUE

Si vous raccordez le cordon d'alimentation de l'appareil à une prise secteur autre que le modèle standard américain de série C73, utilisez un adaptateur de prise secteur appelé "Prise Siemens" comme indiqué.

Pour cet adaptateur secteur, veuillez contacter les distributeurs de votre région.

Adaptateur de prise

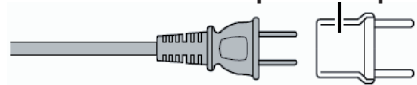

- Retirez l'adaptateur secteur de la prise murale lorsque vous ne l'utilisez pas.
- Veillez à ce que de la poussière ou des objets métalliques n'adhèrent sur la prise murale ou l'adaptateur secteur (prise d'alimentation/CC).

**IMPORTANT (for owners in the U.K.)
Connection to the mains supply in
the United Kingdom.
DO NOT cut off the mains plug from
this equipment.**

If the plug fitted is not suitable for the power points in your home or the cable is too short to reach a power point, then obtain an appropriate safety approved extension lead or contact the local dealers in your area.

BE SURE to replace the fuse only with an identical approved type, as originally fitted, and to replace the fuse cover.

If nonetheless the mains plug is cut off be sure to remove the fuse and dispose of the plug immediately, to avoid possible shock hazard by inadvertent connection to the mains supply.

If this product is not supplied fitted with a mains plug then follow the instructions given below:

DO NOT make any connection to the Larger Terminal coded E or Green. The wires in the mains lead are coloured in accordance with the following code:

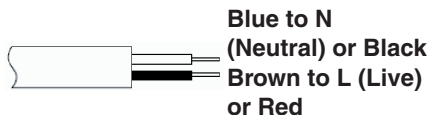

If these colours do not correspond with the terminal identifications of your plug, connect as follows:

Blue wire to terminal coded N (Neutral) or coloured black.

Brown wire to terminal coded L (Live) or coloured Red.

If in doubt — consult a competent electrician.

CAUTIONS:

- To prevent shock, do not open the cabinet. No user serviceable parts inside.
Refer servicing to qualified personnel.
- When you are not using the AC adapter for a long period of time, it is recommended that you disconnect the power cord from AC outlet.

CAUTION:

Where there are strong electromagnetic waves or magnetism, for example near a radio or TV transmitter, transformer, motor, etc., the picture and the sound may be disturbed. In such case, please keep the apparatus away from the sources of the disturbance.

CAUTION:

To avoid electric shock or damage to the unit, first firmly insert the small end of the power cord into the AC Adapter until it is no longer wobbly, and then plug the larger end of the power cord in to an AC outlet.

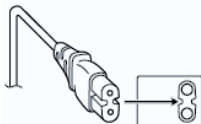

FOR EUROPE

WARNING

This is a Class A product. In a domestic environment this product may cause radio interference in which case the user may be required to take adequate measures.

The plastics packaging bags may cause suffocation when they are covered over the head. Tear them open, and keep them away from the reach of infants and children by ensuring that they are disposed of properly.

■ Para Brasil

Informação sobre eliminação de baterias

Este produto não deverá ser eliminado como lixo doméstico em geral.

Devolva a bateria velha ao comerciante ou para a rede autorizada, para que seja devolvida ao fabricante ou importador.

A reciclagem e eliminação de lixo em uma maneira adequada, ajudarão para preservar recursos, prevenindo, ao mesmo tempo, contra efeitos prejudiciais sobre a nossa saúde e o meio ambiente.

Para Retirar a Bateria Recarregável

Pressione botão e puxe a bateria para fora.

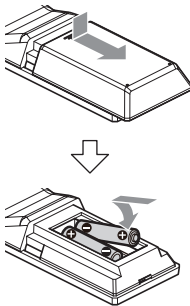

Consult your dealer as special technique is required when installing this product. Ensure that the fixing screws or nuts are tightened securely, otherwise, the unit may fall off.

Mounting to a firm place

As the unit contain parts rotating at high speed, mount it on a firm place with sufficient strength to support the vibration and weight of the unit.

Mass : Approx. 1.7 kg

If the strength is weak, the vibration will cause fuzzy images on the monitor screen. In the worst scenario, the camera may even fall off and hit somebody, resulting in serious accidents.

Mount the camera correctly

When mounting the unit to the ceiling, make sure to use a ceiling mounting bracket.

Be sure to connect the fall prevention wire (sold separately) and tighten the fixing screws or nuts securely.

Using the correct power and voltage

To supply power to this unit, use a DC 12 V or PoE+ (IEEE802.3af) power. Make use of the correct voltage.

Use the supplied AC adapter for the DC 12 V power supply. Do not use the supplied AC adapter on other devices.

Inspect the unit regularly

Screws may be loosened due to vibration or deterioration of the mounting section. Perform regular inspections for loosened screws and check whether there is any danger of the unit falling off.

Do not hang on this product, shake it, or hang objects over it. Applying an excessive load may cause the product to fall off and result in accidents.

Do not modify this product. It may result in accidents.

Do not place any object inside the product. Placing a metallic or inflammable object may cause a fire or shock hazard.

Contents

Getting Started

Safety Precautions	5
Contents	12
Precautions	13
Names of Parts	16
Basic System Diagram	20

Installation/Connection

Mounting the Camera to the Ceiling Mount Bracket	21
Attaching Label to the Camera	21
Installing the Camera on the Ceiling	22
Installing the Camera on a Desktop	23
Attaching the Camera to a Tripod	23
Connecting the Cables	23
Network Features	24
Operating Environment	24
Checking the IP address	24
IP address settings	24
Confirming the Connection	25

Others

Troubleshooting	26
Specifications	27
Software License Agreement	30
Important Notice concerning the Software	31

Content of this Manual

Symbols used

- Caution** : Describes precautions concerning the operation of this product.
- Memo** : Describes reference information, such as functions and usage restrictions of this product.

Content of this manual

- All rights reserved by JVCKENWOOD Corporation. Unauthorized duplication or reprinting of this manual, in whole or in part, is strictly prohibited.
- Illustrated designs, specifications and other contents of this manual are subject to change for improvement without prior notice.
- The terms HDMI and HDMI High-Definition Multimedia Interface, and the HDMI Logo are trademarks or registered trademarks of HDMI Licensing Administrator, Inc. in the United States and other countries.
- NDI is a registered trademark of Newtek, Inc. in the United States.
- macOS is a trademark of Apple Inc., registered in the U.S. and other countries.
- Google Chrome is a trademark and/or registered trademark of Google LLC.
- Microsoft and Windows are registered trademarks of Microsoft Corporation in the United States and other countries.
- Other product and company names included in this instruction manual are trademarks and/or registered trademarks of their respective companies. Marks such as TM and ® have been omitted in this manual.

Precautions

Installation Location

- Be sure to install the camera horizontally.

Storage and Usage Locations

- Allowable ambient temperature and humidity
Be sure to use this unit within the allowable temperature range of 0 °C to 40 °C (32 °F to 104 °F) and a relative humidity of 30 % to 80 %. Using this unit at a temperature or humidity outside the allowable ranges could result not only in malfunction but also serious impact on the CMOS elements as small white spots may be generated. Please exercise care during use.
- Strong electromagnetic waves or magnetism
Noise may appear in the picture or audio and/or the colors may be incorrect if this unit is used near a radio or television transmitting antenna, in places where strong magnetic fields are generated by transformers, motors, etc., or near devices emitting radio waves, such as transceivers or cellular phones.
- Use of wireless microphone near this unit
When a wireless microphone or wireless microphone tuner is used near this unit during recording, the tuner could pick up noise.
- Inadequate heat ventilation may result in malfunction of this product. Be sure not to block vents around the product. This product discharges heat from the surface of the main unit.
- Do not install it at locations directly subjected to cold air such as near the vents of air-conditioners or at locations with high temperature.
- Avoid using or placing this unit in the following places.
 - Locations beyond the allowable operating humidity range of 30 %RH to 80 %RH. (Condensation is not allowed)
 - Near equipment that emits strong magnetic fields, such as transformers or motors.
 - Near equipment that emits radio waves, such as transceivers and mobile phones.
 - Locations with excessive dust and sand.
 - Locations that are subject to vibration such as inside the car or ship.
 - Locations prone to moisture such as window side.
 - Locations subject to steam or oil, such as kitchens.
 - Special environment, such as those with combustible atmosphere.
 - Locations that are subjected to radiation, X-rays, salt attack or corrosive gases.
 - Locations where chemicals are used such as swimming pools.
 - Hot or cold places that are beyond the allowable ambient operating temperature range.

Transportation

- Do not throw away the original box of the unit. Keep it and use it for transporting the unit in future.

Carrying the Camera

- Do not drop or hit this unit against a hard object when transporting.
- Remove the connecting cables when transporting the unit.
- When transporting the unit, turn off the power of the system.
- Pack the unit with cushioning material so as to avoid shock when transporting.
- Handle the unit with care and do not subject it to vibration or shock.

Power Saving

- If the camera is not to be used for a long time, turn off the power of the system for safety and energy conservation reasons.

Maintenance

- Turn off the power before performing any maintenance.
- Wipe the external cabinet of the unit with a soft cloth. Do not wipe the body with benzene or thinner. Doing so may cause the surface to melt or turn cloudy. When it is extremely dirty, soak the cloth in a solution of neutral detergent, wipe the body with it, and then use a clean cloth to remove the detergent.

License Notices

- MPEG LA AVC
THIS PRODUCT IS LICENSED UNDER THE AVC PATENT PORTFOLIO LICENSE FOR THE PERSONAL USE OF A CONSUMER OR OTHER USES IN WHICH IT DOES NOT RECEIVE REMUNERATION TO
 - (i) ENCODE VIDEO IN COMPLIANCE WITH THE AVC STANDARD ("AVC VIDEO") AND/OR
 - (ii) DECODE AVC VIDEO THAT WAS ENCODED BY A CONSUMER ENGAGED IN A PERSONAL ACTIVITY AND/OR WAS OBTAINED FROM A VIDEO PROVIDER LICENSED TO PROVIDE AVC VIDEO.
 NO LICENSE IS GRANTED OR SHALL BE IMPLIED FOR ANY OTHER USE. ADDITIONAL INFORMATION MAY BE OBTAINED FROM MPEG LA, L.L.C. SEE [HTTP://WWW.MPEGLA.COM](http://www.mpegla.com)

Copyright

- Any recordings made on this camera recorder that are played back for profit or public preview may infringe on the rights of the owner of the recordings.
Do not use the recordings for purpose other than personal enjoyment without prior consent from the owner. And even for personal enjoyment, you may not be able to record without permission from the owner.

Login Password

- The default password is widely known. It is very dangerous to use the password without changing it. Set a password that is not easily guessed. It is also recommended to change the password regularly.

Others

- This camera will perform the initial operation of pan/tilt/zoom upon powering on.
- The camera body may be captured in the recording depending on the pan, tilt or zoom position.
- Do not subject the lens to strong light source such as sun rays. This may cause the equipment to malfunction.
- During audio input/output, noise may occur when the rotation mechanism is rotated horizontally/vertically, when zooming is performed or when the power is turned on/off. This is not a malfunction.
- The pan operation range of this product is limited to $\pm 170^\circ$. Regardless of the function, operation is not possible beyond this range.
- Some switching hubs of products that are equipped with intelligent features may include a broadcast/multicast suppression function. Viewing of multicast images on this product may fail if this function is enabled.
- The dark areas on the screen may appear grainy or white spots may increase. When switching between color and black-and-white images, the brighter area on the screen is emphasized, which may reduce the visibility. However, this is not a malfunction.
- If the power supply voltage is momentarily cut off or reduced due to lightning or turning on of the air conditioner's power, the image may be disrupted or noise interference may occur.
- When shooting objects with a luminance difference or near a light source, ghost may occur on the screen. This is a feature of the built-in lens, and is not a malfunction.
- When the monitor in use has a wide display area, lines may appear at the peripheral area of the screen.
- Operation via an infrared remote control unit may not work depending on where and how the camera is installed.

- An afterimage can appear if you view a moving object on the monitor output, however this is not a malfunction.
- Do not put anything into the camera unit.
Metal and flammable items entering from the connectors can result in fire or electric shock.
- The camera recorder may not show stable pictures for a few seconds immediately after the power is turned on, but this is not a malfunction.
- Do not drop this unit or subject it to strong impact or vibration as it is a precision equipment.
- Optical performance of lens
Due to the optical performance of the lens, color divergence phenomena (magnification chromatic aberration) may occur at the periphery of the image. This is not a camera malfunction.
- Noise may appear in the image when switching modes.
- Use the supplied AC adapter for the power supply (DC 12 V). Do not use the supplied AC adapter on other devices.
- Use the supplied power cord. And do not use the supplied power cord for any other devices.

- Before starting an important recording, be sure to perform a test recording in order to confirm that a normal recording is possible.
- We shall not be liable for the loss of recordings or opportunities in the event that recording could not be performed due to a problem that arises during the use of the video camera or recorder.

Names of Parts

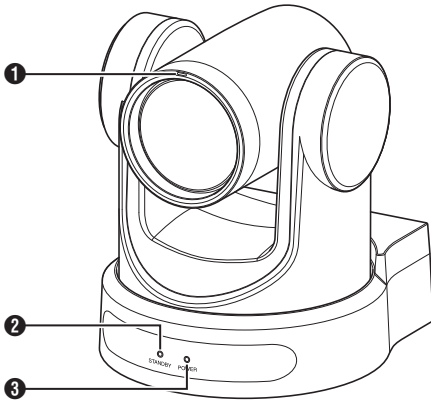

- 1** Tally lamp
Light turns on or goes off during external control. Turns on/off according to the menu setting and blinks depending on the status of this camera.
- 2** STANDBY lamp
Lights up in green during standby.
- 3** POWER lamp
Lights up in blue when the power is turned on.

- 1** LINE OUT terminal
- 2** LINE IN terminal
- 3** DC 12V terminal
- 4** LAN terminal
- 5** USB 2.0 terminal
- 6** 3G-SDI terminal
- 7** HDMI terminal
- 8** RESTORE switch (Reset switch)
- 9** RS232 OUT terminal
- 10** RS232 IN terminal
RS232 communication control
The serial port parameters are as follows.
 - Half duplex mode
 - Baud rate: 2400/4800/9600/38400 bps
 - Start position: 1 bit
 - Data bit length: 8 bits
 - Stop bit length: 1 bit
 - Check digit: None

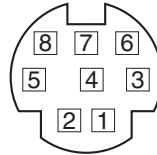

Terminal Section

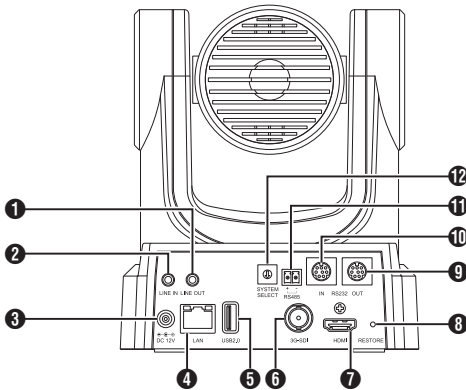

RS-232C IN		RS-232C OUT	
Pin Number	Signal Name	Pin Number	Signal Name
1	DTR_IN	1	DTR_OUT
2	DSR_IN	2	DSR_OUT
3	TXD_IN	3	TXD_OUT
4	GND	4	GND
5	RXD_IN	5	RXD_OUT
6	GND	6	GND
7	IR_OUT	7	NC
8	NC	8	NC

Corresponding Pins between Camera and Windows DB-9

Camera	Windows DB-9
1.DTR	1.CD
2.DSR	2.RXD
3.TXD	3.TXD
4.GND	4.DTR
5.RXD	5.GND
6.GND	6.DSR
7.IR OUT	7.RTS
8.NC	8.CTS
	9.RI

Corresponding Pins between Camera and Mini DIN

Camera	Mini DIN
1.DTR	1.DTR
2.DSR	2.DSR
3.TXD	3.TXD
4.GND	4.GND
5.RXD	5.RXD
6.GND	6.GND
7.IR OUT	7.NC
8.NC	8.NC

⑪ RS485 terminal

- Half duplex mode
- Baud rate:
2400/4800/9600/38400 bps
- Start position: 1 bit
- Data bit length: 8 bits
- Stop bit length: 1 bit
- Check digit: None

⑫ SYSTEM SELECT switch

For selecting a video format for the HDMI or 3G-SDI output.

Terminal Number	Video Format	
	HDMI	3G-SDI
0	1920x1080/60p	1920x1080/60p
1	1920x1080/50p	1920x1080/50p
2	1920x1080/60i	1920x1080/60i
3	1920x1080/50i	1920x1080/50i
4	1920x1080/30p	1920x1080/30p
5	1280x720/60p	1280x720/60p
6	1920x1080/29.97p	1920x1080/29.97p
7	1920x1080/59.94i	1920x1080/59.94i
8	1920x1080/59.94p	1920x1080/59.94p
9	1280x720/59.94p	1280x720/59.94p
A	3840x2160/29.97p	1920x1080/29.97p
B	1920x1080/60p	1920x1080/60p
C	3840x2160/25p	1920x1080/25p
D	3840x2160/30p	1920x1080/30p
E	1920x1080/25p	1920x1080/25p
F	1280x720/50p	1280x720/50p

Infrared Remote Control

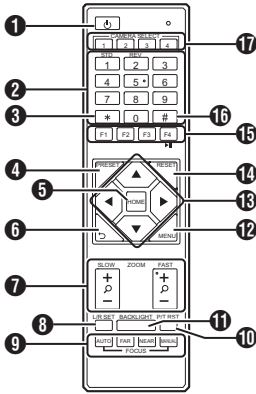

- 1** STANDBY button
Switches between the standby and normal modes.

Memo : _____

Power consumption in the standby mode is approximately half of that in the normal mode.

- 2** NUMBER button
For preset configuration or invoking a preset number.
- 3** * button
To be used together with other buttons.
- 4** PRESET button
Stores the preset position.
[SET PRESET] + NUMBER button (1 to 9):
Stores the preset position in the selected NUMBER button.

Memo : _____

Press the buttons above in sequence.

- 5** HOME button
Restores the orientation of the camera to face the front.
Functions as a confirmation button when the menu is displayed.
- 6** RETURN button
Functions as a cancel button when the menu is displayed.
- 7** ZOOM button
SLOW ZOOM:
Zooms in [+] or zooms out [-] the camera at a low speed.
FAST ZOOM:
Zooms in [+] or zooms out [-] the camera at a high speed.

- 8** L/R SET button

Press the button together with the NUMBER button [1] or [2] at the same time to pans the camera toward the left or right.

- Pressing the left or right side of the [L / R SET] + [1] (STD) at the same time pans the camera toward the left or right accordingly.
- Pressing the left or right side of the [L / R SET] + [2] (REV) at the same time pans the camera toward the right or left accordingly. This setting comes in handy in cases such as when the camera is suspended from the ceiling.

- 9** FOCUS button

For adjusting the focus.

- [AUTO]:
Auto Focus mode (AF)
- [MANUAL]:
Manual Focus mode (MF)
 - During MF, focus is adjusted using [FAR] (for setting focus on a distant subject) and [NEAR] (for setting focus on a nearby subject).

- 10** P/T RST button

Resets the pan and tilt positions.

- 11** BACKLIGHT button

Press the button to enable backlight compensation. Pressing the button again disables backlight compensation.

Memo : _____

- This feature is available only when [Exposure] is configured to "Auto".
- Use this feature when there is a light source behind the subject that causes the subject to appear dark in the image.

- 12** MENU button

Displays the menu or exits the menu display.

- 13** PAN/TILT CONTROL button

Press the arrow button to pan or tilt the camera. Pressing the [HOME] button restores the orientation of the camera to face the front. Moves the cursor when the menu is displayed.

- 14** RESET button

Erases the preconfigured settings.
[RESET] + NUMBER button (0 to 9):
Erases the preset position in the selected NUMBER button.
[*] + [#] + [RESET]:
Erases all the preset positions.

Memo : _____

Press the buttons above in sequence.

15 IR REMOTE CONTROL button

For configuring the number of the camera you want to control using the infrared remote control.

[*] + [#] + [F1]: Address 1

[*] + [#] + [F2]: Address 2

[*] + [#] + [F3]: Address 3

[*] + [#] + [F4]: Address 4

Memo : _____

Press the buttons above in sequence.

16 # button

To be used together with other buttons.

17 CAMERA SELECT button

Press the number of the camera you want to control using the infrared remote control.

Memo : _____

- The remote control unit makes use of 2 AAA dry-cell batteries.
- Make sure to load the battery in the correct +/- orientation.

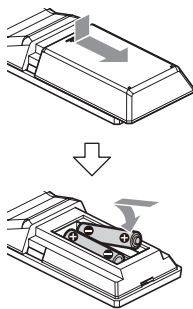

Caution : _____

- Do not place the remote control at a location that is subject to high temperature. Otherwise, the remote control may be deformed, thus resulting in malfunction.
- Place the batteries at a location that is out of reach of children. In the event that the battery is swallowed by mistake, consult a doctor immediately.
- Do not throw the batteries into fire or place them at a location that is subject to high temperature. Otherwise, the batteries may explode.
- When replacing the batteries, use ones that are of the same model or type. Using a different type of battery may cause it to explode.

Image freeze feature

Pressing the [F4] button freezes the video image and displays a "Freeze" caption at the top left corner of the screen for about 5 seconds. Pressing the [F4] button again unfreezes and restores the video image to the original state. An "Unfreeze" caption will appear at the top left corner of the screen for about 5 seconds.

Shortcut settings

[*] + [#] + [1]:

Configures the default language of the menu to English

[*] + [#] + [3]:

Configures the default language of the menu to Chinese

[*] + [#] + [4]:

Displays the current IP address

[*] + [#] + [6]:

Resets all menu settings to the default values.

[*] + [#] + [8]:

Displays the camera version

[*] + [#] + [9]:

Flips the video image horizontally or vertically

[*] + [#] + [MANUAL]:

Restores the default IP address

Memo : _____

Press the buttons above in sequence.

Basic System Diagram

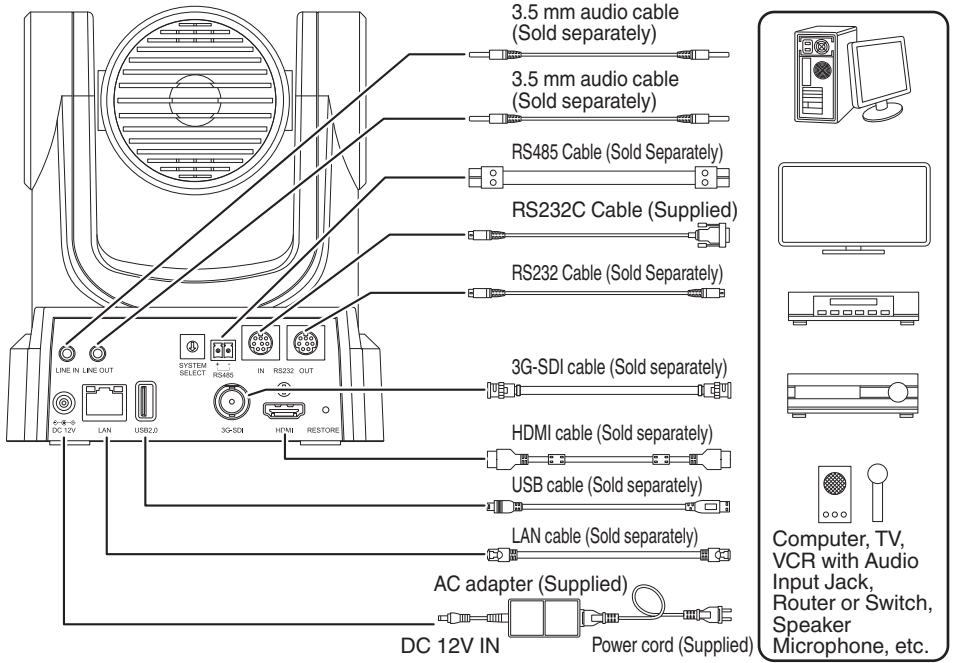

Quick Start

- 1 Check to ensure that the connections are correct before turning on the power.
- 2 Connect the AC adapter to the DC 12 V terminal. The POWER lamp lights up.
- 3 Initialization starts after the camera is powered on. The camera lens moves to both the horizontal and vertical limit positions. Initialization is complete after it has moved back to the front view position.

Memo :

- Operation is possible when the light of the STANDBY lamp has turned off.
- If Preset 1 is preconfigured, the camera will move to the Preset 1 position.

Mounting the Camera to the Ceiling Mount Bracket

- Be sure to put on protective glasses to protect your eyes from falling objects when mounting the camera.
- Be sure to place the base of the camera horizontally. The camera will not operate properly if it is slanted.

Memo : _____

- The ceiling mount bracket is not necessary when the camera is installed on a desktop or attached to a tripod.
- If necessary, make a hole ($\Phi 40$ mm) to route the connection cable and fall prevention wire (ceiling) into the ceiling.

Caution : _____

- The fall prevention wire (for ceiling) is not supplied. Make use of the wire while taking note of its length, strength, pull and material (insulation).
- Attach the fall prevention wire (ceiling) to a place with sufficient strength (ceiling slab, etc.).
- Take note of the length, strength, pull and material (insulation) of the fall prevention wire (for ceiling) and use one with a wire strength of 150 N (15 kg) or more.
- The inner diameter of the ring section of the fall prevention wire (ceiling) mounted on the camera should be above $\Phi 3$ mm but below $\Phi 4$ mm, the outer diameter should be $\Phi 9$ mm and below, and the thickness 2 mm and below.
- The camera does not come with mounting screws for attaching it to the ceiling. Make appropriate use of the M5 expansion screws (x4) according to the thickness of the ceiling.

1 Place the ceiling mounting bracket (ceiling side) against the ceiling and mark the mounting position on the ceiling

Memo : _____

Take note of the front direction of the camera when placing the marks.

2 Drill holes into the ceiling at the marked positions

Memo : _____

Insert a straw or toothpick into the mounting holes to determine the depth and required length of the screws.

3 Place the ceiling mounting bracket (ceiling side) against the ceiling again at the marked position

4 Fasten the mounting bracket using the M5 expansion screws (sold separately)

Memo : _____

Check that the screws are tightened securely when mounting is completed.

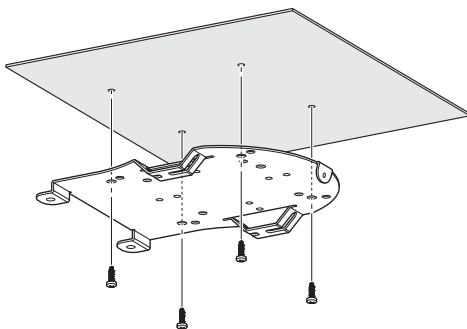

Attaching Label to the Camera

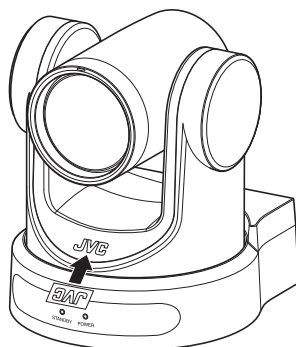

Before installing the camera to the ceiling, attach the JVC logo label as illustrated in the diagram.

- 1 Peel off the label backing.
- 2 Turn the label upside down.
- 3 Align the center position of "V" of the JVC logo on the camera with that on the label, followed by attaching the label.

Memo : _____

- If there is dust or dirt on the surface, remove accordingly before attaching the label.
- Make sure that the JVC logo label is not tilted when attaching.

Installing the Camera on the Ceiling

Configure the video format settings using the SYSTEM SELECT switch before installing.

- 1 Remove the 4 feet from the bottom surface of the camera

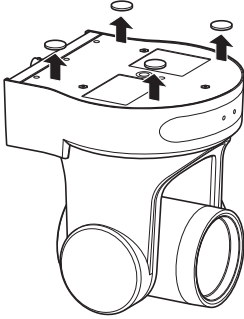

- 2 Use three M3 screws and one 1/4 inch screw that come with the camera to attach the ceiling mounting bracket (camera side) to the bottom surface of the camera

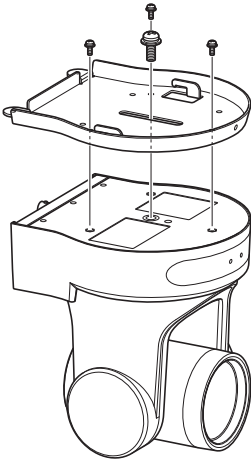

- 3 Mount the camera to the ceiling mount bracket (ceiling side)
Attach the hook on the ceiling mounting bracket (camera side) to the hole on the ceiling mounting bracket (ceiling side).

- 4 Use three M3 screws that come with the camera to attach

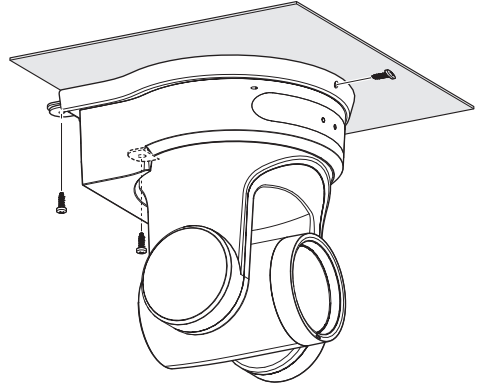

Fasten the drop prevention wire (sold separately) together with one of the screws.

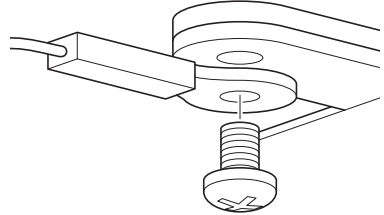

Connect the cables after these procedures.

Installing the Camera on a Desktop

Configure the video format settings using the SYSTEM SELECT switch before installing.

- Place the camera on a flat surface.
- Be sure to place the base of the camera horizontally. The camera will not operate properly if it is slanted.

Memo : _____

- The use of ceiling mount bracket is not required.

Caution : _____

- Do not move the camera while the power of the system is on. Doing so may result in malfunctions or accidents.
- Do not hold the camera head while carrying the camera.

Connect the cables after these procedures.

Attaching the Camera to a Tripod

Configure the video format settings using the SYSTEM SELECT switch before installing.

- Attach a tripod using the screw hole at the bottom of this product.
(1/4-20UNC, ISO1222 (6.35 mm))
- To prevent the camera recorder from falling off, which may result in injuries or damages, read the "INSTRUCTIONS" of the tripod to be used and make sure that it is securely attached.
- To ensure proper pan/tilt operation, set the tripod such that the camera is parallel to the horizontal surface.

Memo : _____

- The use of ceiling mount bracket is not required.

Caution : _____

- If the camera recorder exceeds the weight limit of the tripod, do not mount it on the tripod.
- Use the tripod on a stable surface.
- Use screws with a screw length between 4.5 mm and 7 mm.
- Do not install the camera at a high location when the camera is attached to a tripod.

Connect the cables after these procedures.

Connecting the Cables

1 Connect the cables

- Connecting to an HDMI/SDI monitor allows you to check the camera images.
- To input or output the audio, connect the audio cables respectively to the LINE IN/OUT terminals.

2 Connect the LAN cable.

Caution : _____

Connect to the LAN cable to devices (routers, hubs, computers, etc.) that are certified under the Telecommunications Business Act.

3 Connect the power cable.

- To supply power from an AC adapter, connect an AC adapter cable.
- To supply power via PoE, do not connect the AC adapter cable.

4 After the power turns on, the POWER lamp lights up and initialization starts

The camera lens moves to both the horizontal and vertical limit positions. Initialization is complete after it has moved back to the front view position.

Memo : _____

- Operation is possible when the light of the STANDBY lamp has turned off.
- If Preset 1 is preconfigured, the camera will move to the Preset 1 position.

Caution : _____

- Do not supply power through the AC adapter cable and LAN cable at the same time.

Warning

To supply power to this unit, use a DC 12 V or PoE (IEEE802.3af) power. Make use of the correct voltage. Supplying a power beyond the rated value may result in failures, smoke or fire. If the camera breaks down, turn off the power and contact our service center immediately. When a power beyond the rated value is supplied, the internal components may be damaged even if no abnormality is found on the appearance and operation of the camera. Please contact our service center immediately for servicing (charged separately).

Network Features

Operating Environment

Operation has been verified for the following environments.

- Computer
 - OS: Windows 10
Web browser: Google Chrome
 - OS: macOS 10.12. 6
Web browser: Google Chrome

Checking the IP address

There are two ways to identify the IP address of the camera.

- ① Press *, # and the number 4 button on the remote control in sequence to display the IP address of the camera on the screen of the HDMI/SDI monitor connected to the monitor.
- ② Connect the camera to a PC using a network cable and run “upgrade_standard.exe” to search for the IP address.

Memo : _____

- Download the “upgrade_standard.exe” from the URL stated on the cover page.

IP address settings

There are two ways to configure the IP address of the camera.

- ① Log in to the web page, and select [Network] → [LAN Settings] to make changes to the IP address, subnet mask and gateway. Click “Apply” to restart the camera.
- ② Open “upgrade_standard.exe”, change the IP address, and click “Setting”.

1 Click the [Search] button.

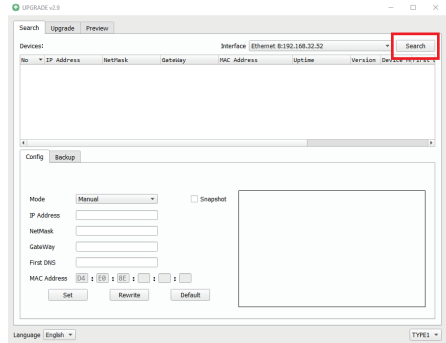

2 Select the IP address of the camera you want to change.

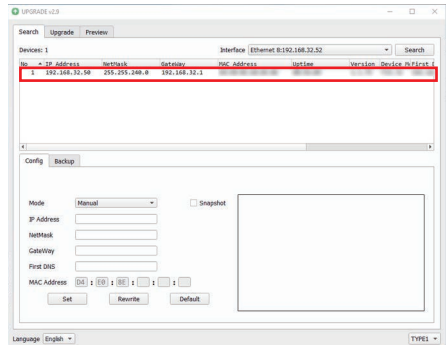

- 3 After changing of “IP Address”, “NetMask”, and “GateWay” is complete, click the [Set] button.

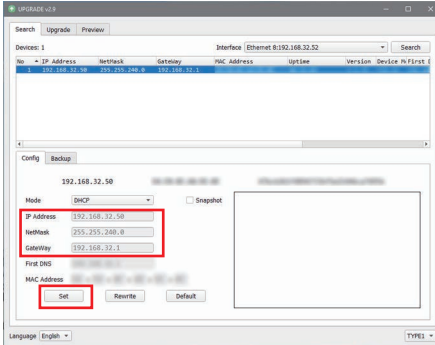

- When the setting is successful, the following display appears and the camera recorder restarts.

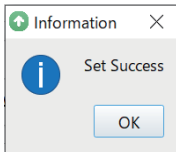

Confirming the Connection

- 1 Start up the web browser on the terminal you wish to connect to the camera recorder, and enter the IP address in the address field.
(Example: http://192.168.0.10)

Memo : _____

- The default IP address of camera is 192.168.0.10.

- 2 Enter the user name and password.

Enter the user name (jvc) and the password (initial password: 0000) on the login screen to display the Live View screen.

Memo : _____

The screen for changing the password is displayed when you log in for the first time. Please change the password.

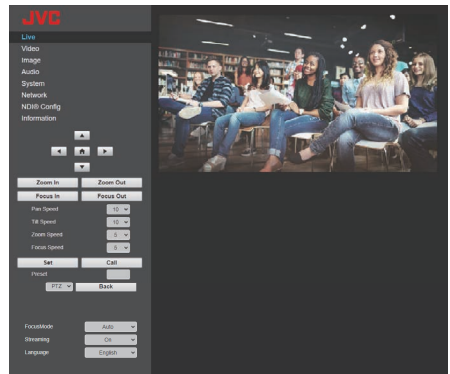

Troubleshooting

Problem	Action
Video image does not appear on the monitor	<ul style="list-style-type: none"> • Check to ensure that the power supply of the camera is properly connected, the power voltage is normal and the POWER lamp is on at all times. • Restart the camera and check whether the camera has been initialized. • Check the video format setting and whether the monitor cable is properly connected.
Sometimes the video image is not displayed	Check the video format setting and whether the monitor cable is properly connected.
Video image becomes blurry when zoomed to the Tele end	<ul style="list-style-type: none"> • Check whether the camera is installed at a stable location. • Check to ensure that there are no vibrating machines or objects near the camera.
Video image does not appear on the Web browser	You can use the VLC media player to receive video and audio streams. Access the VLC website (http://www.videolan.org/vlc) Download and install the VLC media player.
Unable to access camera from the Web browser	<ol style="list-style-type: none"> ① Access the network using a PC to test whether network access is functioning properly. ② Disconnect from the network, connect the camera and the PC separately, and reset the IP address of the PC. ③ Check the IP address, subnet mask and gateway settings of the camera. ④ Check to ensure that there is no conflict in the MAC address. ⑤ Check whether the HTTP port is occupied by a different device.
I forgot the IP address or login password	Manage the password properly to avoid forgetting it. If you forgot the password, reset the camera recorder to return to its default settings. (Default IP address: 192.168.0.10; default user name: jvc; default password: 0000).
Unable to control using the remote control unit	<ul style="list-style-type: none"> • Replace the batteries in the remote control with new ones and check again. • Check whether the camera is in the correct operation mode. • Check whether the camera number configured using the remote control unit matches the number of the camera.
Unable to control via the serial port	<ul style="list-style-type: none"> • Check to ensure that the protocol and address of the camera are consistent. • Check whether the cables are properly connected.
Video and audio distortion during streaming	<ul style="list-style-type: none"> • If the encoder protocol is H.264 or H.265, changing the bit rate may improve the condition. • If the encoder protocol is MJPEG, changing the quantized coefficient may improve the condition.

Specifications

General

Item	Description
Power	DC 12 V (when an AC adapter is used) PoE
Current consumption	0.78 A (*1) 0.22 A (*2)
Mass	Approx. 1.7 kg
Allowable operating temperature	0 °C to 40 °C (32 °F to 104 °F)
Allowable operating humidity	30 %RH to 80 %RH (No condensation)
Allowable storage temperature	-20 °C to 50 °C (-4 °F to 122 °F)
Dimensions (W × H × D)	141.5 mm x 164.5 mm x 168.4 mm
MTBF	> 30000 h

*1 Operated in the factory default settings when an AC adapter is in use.

*2 Operated in the factory default settings when using power supply from a PoE via a LAN cable.

Terminal Section

Item	Description
[LINE IN] terminal	Φ3.5 mm Line input
[LINE OUT] terminal	Φ3.5 mm line output
[RS485] terminal	2-pin Phoenix port Maximum distance: 1200m Protocols: Standard/Pelco-D/ Pelco-P
[RS232 IN] terminal	8-pin mini DIN Maximum distance: 30 m Protocols: Standard/Pelco-D/ Pelco-P
[RS232 OUT] terminal	8-pin mini DIN Maximum distance: 30 m Protocol: Use only Standard network
[LAN] terminal	RJ-45 PoE power supply: DC 37 V to 57 V Ethernet: 10BASE-T/ 100BASE-TX/1000BASE-T

Item	Description
[3G-SDI] terminal	BNC type 720p/1080i/1080p: embedded audio 3G-SDI: SMPTE ST424- compliant HD-SDI: SMPTE ST292- compliant
[HDMI] output terminal	Type A
[USB 2.0] terminal	USB-A type
[DC 12 V] terminal	For use with the supplied AC adapter

Lens/Camera

Item	Description
Lens	12x, f = 4.4 mm to 52.8 mm, F1.8 to F2.6
Image pickup device	1/2.5-inch Progressive CMOS Maximum effective resolution: 851 megapixels
Digital Zoom	16x
Shutter	1/30 s to 1/10000 s
White balance	Auto, Indoor, Outdoor, One- push, Manual
Backlight compensation	Available
Digital noise reduction	3D digital noise reduction
Signal-noise ratio (SNR)	47 dB
H&V flip	Available
Image freeze	Available
No. of presets	255
Preset accuracy	0.1°

Rotation Mechanism Section

Item	Description
Horizontal viewing angle	71° to 8.2°
Vertical viewing angle	42.7° to 4.5°
Horizontal rotation range	±170°
Vertical rotation range	-30° to +90°
Horizontal rotation speed	1.7° to 100°/second
Vertical rotation speed	1.7° to 69.9°/second

Video

Item	Description
Signal system	3840x2160/30p, 25p, 29.97p, 1920x1080/60p, 50p, 30p, 25p, 59.94p, 29.97p, 60i, 50i, 59.94i, 1280x720/60p, 50p, 59.94p

Network

Item	Description
Video compression	H.264/H.265/MJPEG
Video stream	Main stream Sub stream
Main stream resolution	3840x2160, 1920x1080, 1280x720, 1024x576, 720x480, 720x408, 640x480, 640x360
Sub stream resolution	720x480, 720x408, 640x480, 640x360, 480x320, 320x240
Video bit rate	32 kbps to 61140 kbps
Bit rate type	CBR, VBR
Frame rate	50 Hz: 1fps to 50fps 60 Hz: 1fps to 60fps
Audio compression	AAC
Audio bit rate	96K, 128K
Protocols	Control: Standard, NDI@IHX Streaming: RTSP/RTP, RTMP/RTMPS, NDI@IHX, SRT

Infrared Remote Control

Item	Description
Remote control system	Infrared type
Battery	AAA dry-cell battery x 2
Battery life	Approx. 1 year (varies with the frequency of use)
Operating distance	8 m (horizontal distance from the front)
Allowable operating temperature	0 °C to 40 °C (32 °F to 104 °F)
Dimensions (W x H x D)	46 mm x 20.8 mm x 168.1 mm
Mass	Approx. 90 g

Accessories

Accessories	
Warranty Card (U model only)	1
保修卡 (E model only / For China)	1
INSTRUCTIONS (Installation/IP Address Settings)	1
使用说明书(安装/IP地址设置) (E model only / For China)	1
AC Adapter	1
Power Cord (U model: 1, E model: 2)	
RS232C cable	1
Remote control unit	1
Ceiling mount bracket set	1
Screws (M3)	6
Screw (1/4")	1
JVC logo label	2
Lens cap	1

* The warranty card can be found inside the instruction manual.

Dimensional Outline Drawing (Unit: mm)

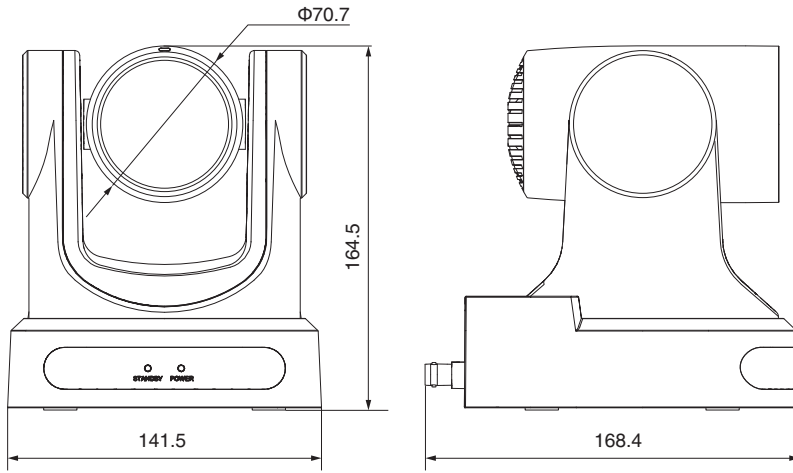

* The specifications and appearance of this product are subject to changes for further improvement without prior notice.

Software License Agreement

The software embedded in the Product (hereinafter the “Licensed Software”) provided by JVCKENWOOD Corporation (hereinafter the “Licensor”) is copyrighted to or sublicensable by the Licensor, and this Agreement provides for the terms and conditions which Users shall follow in order to use the Licensed Software. The User shall use the Licensed Software by agreeing with the terms of this Software License Agreement. This Agreement shall be deemed completed at the time the User (hereinafter the “User”) initially used the Product in which the “Licensed Software” is embedded. The Licensed Software may include the software which has been licensed to the Licensor directly or indirectly from any third party. In such case, some third parties require the Users to follow their conditions for use separately from this Software License Agreement. Such software shall not be subject to this Agreement, and the Users are urged to read the “Important Notice concerning the Software” to be provided separately.

Article 1 General Provision

The Licensor shall grant to the User a non-exclusive and non-transferable (other than the exceptional case referred to in Article 3, Paragraph 1) licensed to use the Licensed Software within the country of the User (the country where the User bought the Product (hereinafter the “Country”).

Article 2 License

1. The license granted under this Agreement shall be the right to use the Licensed Software in the Product.
2. The User shall not duplicate, copy, modify, add, translate or otherwise alter, or lease the Licensed Software and any related documents, whether in whole or in part.
3. The use of the Licensed Software shall be limited to personal purpose, and the Licensed Software shall not be distributed, licensed or sub-licensed whether it is for commercial purpose or not.
4. The User shall use the Licensed Software according to the directions described in the operation manual or help file, and is prohibited to use or duplicate any data in a manner violating the Copyright Law or any other laws and regulations by applying whole or a part of the Licensed Software.

Article 3 Conditions for Grant of License

1. When the User transfers the Product, it may also transfer the license to use the Licensed Software embedded in the Product (including any related materials, updates and upgrades) on condition that no original, copies or related materials continue in the possession of the User, and that the User shall cause the transferee to comply with this Software License Agreement.
2. The User shall not carry out reverse engineering, disassembling, decompiling or any other code analysis works in connection with the Licensed Software.

Article 4 Right pertaining to the Licensed Software

1. Any and all copyrights and other rights pertaining to the Licensed Software and related documents shall belong to the Licensor or the original holder of the right who granted to the Licensor the license or sublicense for the Licensed Software (hereinafter the “Original Rightholder”), and the User shall not be entitled to any right other than the license granted hereunder, in respect of the Licensed Software and any related documents.
2. The User shall, whenever the User uses the Licensed Software, comply with any laws relating to the copyright and other intellectual property rights.

Article 5 Indemnification of Licensor

1. Neither the Licensor nor the Original Rightholder shall be liable for any damage incurred by the User or any third party due to the exercise of the license granted to the User under this Agreement, unless otherwise restricted by law.
2. The Licensor will offer no guarantee for the merchantability, convertibility and consistency with certain objective of the Licensed Software.

Article 6 Liability to Third Party

If any dispute has arisen with any third party due to an infringement upon a copyright, patent or any other intellectual property right that was caused by the User’s use of the Licensed Software, the User shall settle such dispute at the User’s own cost and hold the Licensor and the Original Rightholder harmless from any inconvenience it may cause.

Article 7 Confidentiality

The User shall keep the confidentiality of such portion of the Licensed Software, related documents thereof or any other information to be granted under this Agreement, as well as the conditions of this Agreement as has not yet entered the public domain, and shall not disclose or divulge the same to any third party without approval of the Licensor.

Article 8 Termination

In case the User falls under any of the events described in the following items, the Licensor may immediately terminate this Agreement or claim that the User compensates for the damage incurred by the Licensor due to such event:

- (1) when the User violated any provision of this Agreement; or
- (2) when a petition has been filed against the User for an attachment, provisional attachment, provisional disposition or any other compulsory execution.

Article 9 Destruction of the Licensed Software

If this Agreement is terminated pursuant to the provision of Article 8, the User shall destroy the Licensed Software, any related documents and copies thereof within two (2) weeks from such date of termination.

Article 10 Export Restriction

1. The User shall understand that the Licensed Software shall be subject to the export restrictions adopted by the country of User and any other countries.
2. The User shall agree that the software will be subject to any and all applicable international and domestic laws including the export control regulation of the country of User and any other countries, and any restrictions concerning the end-users, the use by end-users and importing countries to be provided by the country of User and any other countries, and any other governmental authorities.
3. If the User is an agency of the United States of America (the "Government"), the User acknowledge Licensor's representation that the Licensed Software is a "Commercial Item" as defined in Federal Acquisition Regulation (FAR) part 2.101(g) consisting unpublished "Commercial Computer Software" as those items are used at FAR part 12.212 and is only license the User with the same use right Licensor grants all commercial end users pursuant to the terms of this Agreement.

Article 11 Miscellaneous

1. In the event any part of this Agreement is invalidated by operation of law, the residual provisions shall continue in force.
2. Matters not stipulated in this Agreement or any ambiguity or question raised in the construction of this Agreement shall be provided or settled upon good-faith consultation between the Licensor and the User.
3. The Licensor and the User hereby agree that this Agreement is governed by the laws of Japan, and any dispute arising from, and relating to the rights and obligations under, this Agreement shall be submitted to the exclusive jurisdiction of the Tokyo District Court for its first instance.

Important Notice concerning the Software

Software License Attached to the Product :

The Software embedded in the Product is composed of several independent software components, and in each of such individual components (hereinafter the "Licensed Software"), a copyright of either JVCKENWOOD Corporation (hereinafter "JKC") or a third party subsists.

The Product uses the software component designated in the End-User License Agreement that was executed between JKC and a third party (hereinafter "EULA").

The Licensed Software covers those corresponding to free software, and, as a condition of distribution of the software component in executable format which is based on the license granted under the GNU General Public License or Lesser General Public License (hereinafter "GPL/LGPL"), it requires an availability of the source code for the relevant component. Please refer to the following URL concerning the distribution of the source code;

<https://www3.jvckenwood.com/english/download/gpl/index.html>

Please note that we are unable to answer any inquiry relating to the contents, etc. of the source code. In addition, the Licensed Software includes the software developed or created independently by JKC and there exists an ownership of JKC in such software and any accompanying documents, which is protected by the Copyright Law, any international treaties and other applicable laws. As to matters concerning the handling by JKC of the software components, please refer to the "Software License Agreement" attached hereto. Please note that any software component licensed under "EULA" which is not subject to "GPL/LGPL", and those developed or created independently by JKC shall not be subject to the requirement for provision of the source code. The software component distributed under "GPL/LGPL" shall be licensed to users without charge, and, therefore, no warranty is given for such software component, either express or implied, within the scope of the applicable laws and regulations. Unless otherwise permitted by applicable laws and regulations or agreed in written form, none of the owners of the copyright or persons entitled to alter or redistribute the software component under the said license shall have any liability for any type of damage or loss resulting from the use of or inability to use such software component. For further details of the conditions of use of such software component or matters required to be complied with, please refer to the relevant "GPL/LGPL".

Users are urged to read the details for the relevant license carefully before using the software component covered by "GPL/LGPL" and embedded in the Product. Since the terms and conditions of individual licenses are provided by parties other than JKC, the original English version will be displayed by the Product or the Settings screen.

- ① Access the camera from the Web browser
- ② Click "Information" on the left side of the screen
- ③ Press the "Open Source License" button in the "Information" menu screen

Information on Disposal of Old Electrical and Electronic Equipment and Batteries (applicable for countries that have adopted separate waste collection systems)



Products and batteries with the symbol (crossed-out wheeled bin) cannot be disposed as household waste. Old electrical and electronic equipment and batteries should be recycled at a facility capable of handling these items and their waste by products.



Contact your local authority for details in locating a recycle facility nearest to you. Proper recycling and waste disposal will help conserve resources whilst preventing detrimental effects on our health and the environment.



Notice: The sign "Pb" below the symbol for batteries indicates that this battery contains lead.

Information sur l'élimination des anciens équipements électriques et électroniques et piles électriques (applicable dans les pays de qui ont adopté des systèmes de collecte sélective)



Les produits et piles électriques sur lesquels le pictogramme (poubelle barrée) est apposé ne peuvent pas être éliminés comme ordures ménagères. Les anciens équipements électriques et électroniques et piles électriques doivent être recyclés sur des sites capables de traiter ces équipements et leurs déchets par produit.



Contactez vos autorités locales pour connaître le site de recyclage le plus proche.



Un recyclage adapté et l'élimination des déchets aideront à conserver les ressources et à nous préserver des leurs effets nocifs sur notre santé et sur l'environnement.

Avis: Le symbole "Pb" ci-dessous sur des piles électrique indique que cette pile contient du plomb.

Información acerca de la eliminación de equipos eléctricos, electrónicos y baterías al final de la vida útil (aplicable a los países de la que hayan adoptado sistemas independientes de recogida de residuos)



Los productos y las baterías con el símbolo (contenedor con ruedas tachado) no podrán ser desechados como residuos domésticos.



Los equipos eléctricos, electrónicos y baterías al final de la vida útil, deberán ser reciclados en instalaciones que puedan dar el tratamiento adecuado a estos productos y a sus subproductos residuales correspondientes.



Póngase en contacto con la autoridad local competente para obtener información sobre el centro de reciclaje más cercano. El reciclaje y la disposición adecuada de los desechos ayuda a conservar los recursos naturales y a reducir los efectos perjudiciales en la salud y el medio ambiente.

Nota: El símbolo "Pb" debajo del símbolo en baterías indica que dicha batería contiene plomo.

Informação sobre a Eliminação de Equipamentos Eléctricos e Electrónicos e de Baterias usados (aplicável nos países que adoptam sistemas de recolha diferenciada de lixo)



Os produtos e baterias com o símbolo (caixote de lixo com um X) não podem ser deitados fora junto com o lixo doméstico.



Os equipamentos eléctricos e electrónicos e baterias usados devem ser reciclados em uma instalação capaz de manipular esses elementos e seus subprodutos residuais.



Contacte a autoridade local para os detalhes sobre a localização da instalação de reciclagem mais próxima. A reciclagem e eliminação de lixo adequadas ajudarão a preservar os recursos naturais e prevenir efeitos prejudiciais à nossa saúde e meio ambiente.

Aviso: O sinal "Pb" abaixo do símbolo para baterias indica que esta bateria contém chumbo.

Informazioni sull'eliminazione dei prodotti elettrici ed elettronici e delle batterie (per i Paesi che adottano la raccolta differenziata dei rifiuti)



I prodotti e le batterie recanti questa icona (bidone carrellato della spazzatura con il simbolo della croce) non devono essere eliminati come rifiuti solidi urbani. I prodotti elettrici ed elettronici e le batterie devono essere riciclati presso centri idonei alla loro gestione e a quella dei rispettivi sottoprodotto.



Per informazioni sul centro di riciclaggio più vicino si suggerisce di rivolgersi alle autorità locali.



Se eseguiti adeguatamente, l'eliminazione e il riciclaggio dei rifiuti aiutano a conservare le risorse e al contempo impedire gli effetti nocivi sulla salute e l'ambiente.

Avviso: Il contrassegno "Pb" che appare sotto il simbolo delle batterie significa che contengono piombo.

Entsorgung von gebrauchten elektrischen und elektronischen Geräten und Batterien (anzuwenden in Ländern mit einem separaten Sammelsystem für solche Geräte)



Das Symbol (durchgestrichene Mülltonne) auf dem Produkt oder seiner Verpackung weist darauf hin, dass dieses Produkt nicht als normaler Haushaltsabfall behandelt werden darf.



Die betreffenden Produkte müssen an einer Annahmestelle für das Recycling von elektrischen und elektronischen Geräten und Batterien abgegeben werden.



Weitere Informationen über das Recycling dieses Produktes erhalten Sie von Ihrer Gemeinde oder den kommunalen Entsorgungsbetrieben.

Unschonmäßige oder falsche Entsorgung gefährden Umwelt und Gesundheit.

Zur Beachtung: Das Zeichen „Pb“ unter dem Symbol für Batterien zeigt an, dass diese Batterie Blei enthält.

Informatie over het weggevoien van oude elektrische en elektronische apparaten en batterijen (voor landen die gescheiden afvalverzamelsystemen gebruiken)



Producten en batterijen met het (afvalcontainer met x-teken) symbool mogen niet als normaal huisvuil worden weggegooid.



Oude elektrische en elektronische apparaten en batterijen moeten worden gerecycleerd door een faciliteit die geschikt is voor het verwerken van dergelijke voorwerpen.



Raadgeleg de betreffende lokale instantie voor details aangaande in de buurt zijnde recyclingfaciliteiten. Het juist recyclen en weggevoien van afval spaart natuurlijke bronnen en reduceert schadelijke invloed op uw gezondheid en het milieu.

Opmerking: De "Pb" aanduiding onder het batterijsymbool betekent dat deze batterij lood bevat.

Πληροφορίες για την Απόρριψη παλιών ηλεκτρικών και ηλεκτρονικών συσκευών και μπαταριών (όπως ισχύουν για χώρες που έχουν υιοθετήσει ξεχωριστό σύστημα αποβλήτων)



Τα προϊόντα και οι μπαταρίες με το σύμβολο (διαγραμμένος κάδος αχρήστων) δεν μπορούν να απορριφθούν ως οικιακά απορρίμματα.



Οι παλιές ηλεκτρικές και ηλεκτρονικές συσκευές και οι μπαταρίες θα πρέπει να ανακυκλώνονται σε εγκαταστάσεις που έχουν τη δυνατότητα να διαχειριστούν αυτά τα αντικείμενα και τα υποπροϊόντα της απόρριψής τους.



Επικοινωνήστε με τις τοπικές υπηρεσίες για λεπτομέρειες σχετικά με την εύρεση της πλησιέστερης εγκατάστασης ανακύκλωσης. Η σωστή ανακύκλωση και η εξουδετέρωση των απορριμμάτων συντελεί στη διατήρηση των πόρων ενώ αποτρέπει τις αρνητικές επιπτώσεις στην υγεία μας και στο περιβάλλον.

Προσοχή: Το σήμα "Pb" κάτω από το σύμβολο για τις μπαταρίες δηλώνει πως η μπαταρία περιέχει μόλυβδο.

Bu ürün 28300 sayılı Resmi Gazete'de yayımlanan Atık Elektrikli ve Elektronik Eşyaların Kontrolü Yönetmeliğe uygun olarak üretilmiştir.

Eski Elektrikli ve Elektronik Cihazların ve Pillerin İmhası Hakkında Bilgi (ayrı atık toplama sistemlerine sahip olan ülkelerde geçerlidir)



Bu sembolü (üzeri çizili çöp bidonu) içeren ürün ve piller evsel atık çöpleri ile birlikte atılamaz. Kullanılmış elektrikli ve elektronik cihaz ve piller, bu tür maddeleri ve bunların yan ürünlerini işleme elverişli bir geri kazanım tesisine gönderilmelidir.



Size en yakın geri kazanım tesisinin konumunu öğrenmek üzere yerel yetkililerinize danışın.



Doğru geri kazanım ve atık uzaklaştırma yöntemleri, sadece öz kaynakların korunmasına yardımcı olmakla kalmayıp ayrıca sağlığınıza ve çevreye olacak zararlı etkilerini engellemeye yardımcı olur.

Uyarı: Pilin alt tarafında bulunan "Pb" işareti, bu pillin kurşun içerdiğini belirtir.

Informacije za korisnike o odlaganju stare opreme



[primenljivo u zemljama koje su usvojile direktivu o sistemima sortiranja i razdvajanja otpada]

Ovi simboli ukazuju da produkt sa ovim simbolom i baterije ne treba odlagati kao nesortiran kućni otpad kada im istekne vek trajanja. Umesto toga, proizvod treba predati važećim otpadima za reciklažu električne i elektronske opreme (kao i baterija) radi pravilnog postupanja u skladu sa vašim nacionalnim zakonodavstvom.



Ispravnim odlaganjem ovog proizvoda pomažete očuvanju prirodnih resursa i prevenciji potencijalnih negativnih efekata na okolinu i ljudsko zdravlje koji bi inače bili prouzrokovani nepravilnim rukovanjem otpadom od ovih proizvoda.

Za više informacija o otpadima i reciklaži ovog proizvoda, molimo vas da kontaktirate vašu lokalnu opštinsku kancelariju, vaše javno komunalno preduzeće ili prodavnicu u kojoj ste kupili proizvod. Ako vaš korišćeni proizvod sadrži baterije ili akumulatore, molimo vas da ih unapred odložite zasebno u skladu sa lokalnim zahtevima.

(Za poslovne korisnike)

Ako želite da odložite ove proizvode, molimo vas da kontaktirate vašeg prodavca ili dobavljača za više informacija.

Naznaka: Hemijski simbol Pb ispod simbola za baterije ukazuje na to da li baterija sadrži olovo.

Информации за Отстранување на стара електрична и електронска опрема и батерии (вани за земји кои имаат усвоено посебен отпад системи)



Производи и батерии со симбол (пречкртана бин) не може да биде отстранет како домашен отпад. Стара електрична и електронска опрема и батерии треба да се рециклираат во еден објект способни за ракување со овие предмети и нивниот отпад од производи. Контакттирајте го вашиот локален орган за детали за лоцирање на рециклирање објект најблиску до вас.



Правилно рециклирање и депонирање на отпадот ќе ви помогне зачува ресурси додека спречување на штетните ефекти врз нашето здравје и животната средина.

Напомена: накот "Pb" под симболот за батерију кажува на тоа дека оваа батерија содржи олово.

מידע בדבר השלכה לאשפה של ציוד חשמלי ואלקטרוני ישן וכן סוללות (רלוונטי למדינות שמתמשות במערכת איסוף אשפה מופרדת).

לא ניתן להשליך מוצרים וסוללות עם הסיומן (פח אשפה עם X עליו) כאשפה ביתית רגילה. יש למחזר ציוד חשמלי ואלקטרוני ישן וכן סוללות במתקן המסוגל לספול בפריטים כאלה ובתוצרי הלוואי שלהם.

צרו קשר עם הרשות המקומית לקבלת פרטים אודות מתקן המחזור הקרוב אליכם. מיחזור והשלכה לאשפה נאותים יעזרו לשמר משאבים ולמנוע השפעות שליליות על בריאותנו ועל הסביבה.

שמי לב: הסיומן Pb שמתחת לסיומן עבור סוללות מצוין שהסוללה מכילה עופרת.



Importer (UK only)

JVCKENWOOD U.K. Limited
First Floor, Gleneagles, the Belfry, Colonial Way,
Watford, Hertfordshire WD24 4WH,
UNITED KINGDOM

Importeur (Nur EU)

JVCKENWOOD Deutschland GmbH
Konrad-Adenauer-Allee 1-11, 61118 Bad Vilbel,
DEUTSCHLAND

Importatore (Solo EU)

JVCKENWOOD Italia S.p.A.
Via G. Sirtori 7/9, 20129 Milano, ITALIA

Importeur (Aleen EU)

JVCKENWOOD Europe B.V.
Amsterdamseweg 37, 1422 AC Uithoorn,
NEDERLAND

Manufacturer

JVCKENWOOD Corporation
3-12, Moriya-cho, Kanagawa-ku, Yokohama-shi,
Kanagawa, 221-0022, JAPAN



LIMITED WARRANTY

PRO. PRODUCTS 2-1 CI

JVCKENWOOD USA Corporation (JVC) warrants this product and all parts thereof, except as set forth below ONLY TO THE ORIGINAL END-USER PURCHASER to be FREE FROM DEFECTIVE MATERIALS AND WORKMANSHIP from the date of the original purchase for the period shown below. ("The Warranty Period")

Model	Serial No.	Parts	Labor
KY-PZ400NWU KY-PZ400NBU		2YR	1YR

THIS LIMITED WARRANTY IS VALID ONLY IN THE FIFTY (50) UNITED STATES, THE DISTRICT OF COLUMBIA AND IN THE COMMONWEALTH OF PUERTO RICO.

WHAT WE WILL DO:

If this product is found to be defective within the warranty period, JVC will repair or replace defective parts with new or rebuilt equivalents at no charge to the original owner. Such repair and replacement services shall be rendered by JVC during normal business hours at JVC authorized service centers. Parts used for replacement are warranted only for the remainder of the Warranty Period.

WHAT YOU MUST DO FOR WARRANTY SERVICE:

Box the product carefully, preferably in the original carton and ship to the nearest JVC authorized service center. It is recommended that you insure the product against loss or damage. To obtain the address of the nearest authorized service center, please call (800) 582-5825. Service locations can also be obtained from our website at <http://www.us.jvckenwood.com>.

Please be sure to include a copy of your bill of sale to substantiate warranty (if applicable) and a note detailing the problem. If you have any questions concerning your JVC Product, please contact our Customer Relations Department at 800-582-5825.

SEE OTHER SIDE

JVCKENWOOD USA Corporation

PO Box 22745, 2201 E. Dominguez St,
Long Beach, CA 90810-5745

PRODUCT SAFETY REGISTRATION CARD

To help us better serve you, we request you to return this "PRODUCT SAFETY REGISTRATION CARD". The information will enable us to contact you quickly if it is ever necessary to correct a safety related condition in this product.

Thank you for helping us to service you better.

Please fill in the requested information and mail or you can register your product online at: <http://www.jvc.com/pro>

THIS IS NOT A WARRANTY REGISTRATION CARD. PLEASE RETAIN YOUR BILL OF SALE FOR PROOF OF WARRANTY.

First Name Initial Last Name

Organization Title

Address (Number and Street) Apt #

City State/Province Zip

Phone Number Email Address Please add me to your mailing list.

Date of Purchase Month Day Year Model Number Serial Number

Name of Dealer where purchased/Address/Phone Number

This form is for Product Registration purpose only. Failure to return this form does not diminish your rights during the warranty period.