

OPERATION MANUAL

LTR-200HS7

LTO-7 Video Archiving Recorder

1st Edition





Edition Revision History

Edition	Revision	Date	Description	Section/Page
1	-	2016/12/16	First edition	



Precautions

Important Safety Warnings



[Power]

 Caution	Operate unit only at the specified supply voltage.
 Caution	Disconnect the power cord via the power plug only. Do not pull on the cable portion.
 Stop	Do not place or drop heavy or sharp-edged objects on the power cord. A damaged cord can cause fire or electrical shock hazards. Regularly check the power cord for excessive wear or damage to avoid possible fire / electrical hazards.
 Caution	Ensure the power cord is firmly plugged into the AC outlet.

[Grounding]

 Caution	Ensure the unit is properly grounded at all times to prevent electrical shock.
 Hazard	Do not ground the unit to gas lines, units, or fixtures of an explosive or dangerous nature.



[Operation]

 Hazard	Do not operate the unit under hazardous or potentially explosive atmospheric conditions. Doing so could result in fire, explosion, or other hazardous results.
 Hazard	Do not allow liquids, metal pieces, or other foreign materials to enter the unit. Doing so could result in fire, other hazards, or a unit malfunction.
 Caution	If a foreign material does enter the unit, turn the power off and immediately disconnect the power cord. Remove the material and contact an authorized service representative if damage has occurred.

[Transportation]

 Caution	Handle with care to avoid impact shock during transit, which may cause malfunction. When you need to transport the unit, use the original or suitable alternative packing material.
--	--

[Circuitry Access]

	<p>Do not remove covers, panels, casing, or access the circuitry with power applied to the unit. Turn the power off and disconnect the power cord prior to removal. Internal servicing / adjustment of unit should only be performed by qualified personnel.</p>
 <p>Stop</p>	<p>Do not touch any parts / circuitry with a high heat factor. Capacitors can retain enough electric charge to cause mild to serious shock, even after the power has been disconnected. Capacitors associated with the power supply are especially hazardous.</p>
 <p>Hazard</p>	<p>Unit should not be operated or stored with cover, panels, and / or casing removed. Operating the unit with circuitry exposed could result in electric shock / fire hazards or a unit malfunction.</p>

[Potential Hazards]

 <p>Caution</p>	<p>If abnormal odors or noises are noticed coming from the unit, immediately turn the power off and disconnect the power cord to avoid potentially hazardous conditions. If problems similar to the above occur, contact an authorized service representative before attempting to operate the unit again.</p>
--	---

[Rack Mount Brackets, Ground Terminal, and Rubber Feet]

 <p>Caution</p>	<p>To rack-mount or ground the unit, or to install rubber feet, do not use screws or materials other than those supplied. Doing so may cause damage to the internal circuits or components of the unit. If you remove the rubber feet that are attached to the unit, do not reinsert the screws that secure the rubber feet.</p>
--	--

[Consumables]

 <p>Caution</p>	<p>Consumable items that are used in the unit must be periodically replaced. For further details on which parts are consumables and when they should be replaced, refer to the specifications at the end of the Operation Manual. Since the service life of the consumables varies greatly depending on the environment in which they are used, such items should be replaced at an early date. For details on replacing consumable items, contact your dealer.</p>
--	---

Precautions for LTO Tape/Drive Use

Although our products are fully inspected and adjusted prior to shipment, please keep in mind the following points.

1. Recording may suddenly abort due to a hardware malfunction or unexpected failure in rare cases.
We cannot guarantee or be held responsible for the loss or modification of contents.
2. We highly recommend configuring a redundant LTO system, due to the possibility of data recording, writing, playing or loading failure caused by an LTO tape or drive malfunction.
3. If an error occurs while reading or writing the LTO tape, a number will be displayed on the single-character display (SCD) (see 5-1-1. "Status Lights") to the right of the LTO tape cartridge loading slot. In such case, see Appendix A-1. "Error Codes and Messages."
4. Do not press the FORCE EJECT button (small hole or blue round button) for more than 10 sec. (LTO tape data may otherwise become corrupted) unless it is for an emergency (tape cannot eject, etc.).
5. To write-protect tapes, eject an LTO tape from the drive and slide the write-protect switch to close the opening. Do not slide the switch while an LTO tape is in the drive.
6. If LTO tapes are not to be used for long periods of time, eject them from drive/s in the proper manner and store them in their plastic container to protect them from dust, dirt, or other foreign materials. Do not keep them in LTO drive/s. Doing so will result in errors.
7. Before powering ON the LTO unit, ensure that no condensation has formed on the unit, which may result in malfunction. Do not power on the unit until moisture has evaporated and the unit temperature is closer to the ambient temperature. Waiting for about 4 hours before use is recommended when moving the unit from a cold to warm environment or vice versa.
8. When moving LTO tapes to a location having different environmental temperature / humidity conditions, allow enough time for the tapes to gradually adapt to the new environment before reading or writing to them. Over 5 hours may be required if the temperature difference is greater than 7°C or the difference in relative humidity is greater than 13%. More than 13 hours may be required if the temperature difference is greater than 13°C or the difference in relative humidity is greater than 27%. Insufficient adaptation may cause reading or writing errors.
9. Writing retry operations may occur depending on LTO tape or head conditions and reduce the amount of available free space on tapes. Tape data, therefore, may in some cases be unable to be copied due to space restrictions caused by retries. To use auto-copy functions, set the maximum amount of tape cartridge usage to less than 90%.
10. FOR-A Company and its resellers are not liable for any direct, indirect, incidental or consequential damage in any way related to products (including without limitation damages for lost profits and/or data).

* Please note that we will not be liable for any loss or damages arising from or resulting in the use of this product.
* The product specifications and the information in this manual are subject to change without notice.

* Refer to Appendix C for IBM LTFS details.

* **MediaConcierge** is a trademark of FOR-A Company Limited.

* **AVC-Intra** and **DVCPRO** are trademarks of Panasonic Corporation.

* **Microsoft**, **Microsoft Windows** and **Windows Media Technology** are either registered trademarks or trademarks of Microsoft Corporation in the United States and/or other countries.

* **LTO** is a trademark of HP, IBM and Quantum.

* **MP-Factory(R)5.0**

Copyright (C) 1998-2010 KDDI R&D Labs. Inc.

KDDI R&D LABS, **MP-Factory** and their logos are either registered trademarks or trademarks of KDDI Corporation or KDDI R&D Laboratories Inc..

STL

The following software License applies to the STL (Standard Template Library) implementation used by the MXFComponentSuite: Copyright (c) 1994 Hewlett-Packard Company

Permission to use, copy, modify, distribute and sell this software and its documentation for any purpose is hereby granted without fee, provided that the above copyright notice appear in all copies and that both that copyright notice and this permission notice appear in supporting documentation.

Hewlett-Packard Company makes no representations about the suitability of this software for any purpose. It is provided "as is" without express or implied warranty.

Copyright (c) 1996,1997 Silicon Graphics Computer Systems, Inc.

Permission to use, copy, modify, distribute and sell this software and its documentation for any purpose is hereby granted without fee, provided that the above copyright notice appear in all copies and that both that copyright notice and this permission notice appear in supporting documentation. Silicon Graphics makes no representations about the suitability of this software for any purpose.

It is provided "as is" without express or implied warranty.

SlimFTPd

Copyright (C) 2006, Matt Whitlock and WhitSoft Development, All rights reserved.

Info-ZIP

This is version 2007-Mar-4 of the Info-ZIP license.

The definitive version of this document should be available at <ftp://ftp.info-zip.org/pub/infozip/license.html> indefinitely and a copy at <http://www.info-zip.org/pub/infozip/license.html>.

Copyright (c) 1990-2007 Info-ZIP. All rights reserved.

For the purposes of this copyright and license, "Info-ZIP" is defined as the following set of individuals:

Mark Adler, John Bush, Karl Davis, Harald Denker, Jean-Michel Dubois, Jean-loup Gailly, Hunter Goatley, Ed Gordon, Ian Gorman, Choursis Herborth, Dirk Haase, Greg Hartwig, Robert Heath, Jonathan Hudson, Paul Kienitz, David Kirschbaum, Johnny Lee, Onno van der Linden, Igor Mandrichenko, Steve P. Miller, Sergio Monesi, Keith Owens, George Petrov, Greg Roelofs, Kai Uwe Rommel, Steve Salisbury, Dave Smith, Steven M. Schweda, Choursistian Spieler, Cosmin Truta, Antoine Verheijen, Paul von Behoursen, Rich Wales, Mike White.

This software is provided "as is," without warranty of any kind, express or implied. In no event shall Info-ZIP or its contributors be held liable for any direct, indirect, incidental, special or consequential damages arising out of the use of or inability to use this software.

Permission is granted to anyone to use this software for any purpose, including commercial applications, and to alter it and redistribute it freely, subject to the above disclaimer and the following restrictions:

1. Redistributions of source code (in whole or in part) must retain the above copyright notice, definition, disclaimer, and this list of conditions.
2. Redistributions in binary form (compiled executables and libraries) must reproduce the above copyright notice, definition, disclaimer, and this list of conditions in documentation and/or other materials provided with the distribution. The sole exception to this condition is redistribution of a standard UnZipSFX binary (including SFXWiz) as part of a self-extracting archive; that is permitted without inclusion of this license, as long as the normal SFX banner has not been removed from the binary or disabled.
3. Altered versions--including, but not limited to, ports to new operating systems, existing ports with new graphical interfaces, versions with modified or added functionality, and dynamic, shared, or static library versions not from Info-ZIP--must be plainly marked as such and must not be misrepresented as being the original source or, if binaries, compiled from the original source. Such altered versions also must not be misrepresented as being Info-ZIP releases--including, but not limited to, labeling of the altered versions with the names "Info-ZIP" (or any variation thereof, including, but not limited to, different capitalizations), "Pocket UnZip," "WiZ" or "MacZip" without the explicit permission of Info-ZIP. Such altered versions are further prohibited from misrepresentative use of the Zip-Bugs or Info-ZIP e-mail addresses or the Info-ZIP URL(s), such as to imply Info-ZIP will provide support for the altered versions.
4. Info-ZIP retains the right to use the names "Info-ZIP," "Zip," "UnZip," "UnZipSFX," "WiZ," "Pocket UnZip," "Pocket Zip," and "MacZip" for its own source and binary releases.

LIBSSH2

Copyright (c) 2004-2007 Sara Golemon <sarag@libssh2.org>
Copyright (c) 2005,2006 Mikhail Gusarov <dottedmag@dottedmag.net>
Copyright (c) 2006-2007 The Written Word, Inc.
Copyright (c) 2007 Eli Fant <elifantu@mail.ru>
Copyright (c) 2009 Daniel Stenberg
Copyright (C) 2008, 2009 Simon Josefsson
All rights reserved.

Intel(R) JPEG Library 1.5

Copyright(C) 1998-2000 Intel Corporation.

Intel(R) Image Processing Library 2.5

Copyright(C) 1998 Intel Corporation

* All other trademarks and copyrights are property of their respective owners. All rights reserved.

Upon Receipt

Unpacking

LTR-200HS7 units and their accessories are fully inspected and adjusted prior to shipment. Operation can be performed immediately upon completing all required connections and operational settings.

Check your received items against the packing lists below.

ITEM	QTY	REMARKS
LTR-200HS7	1	
AC Cord	1 set	Cable Retainer included
LTO cleaning cartridge	1	
CD-ROM	1	LTR-200HS7 Operation Manual (PDF) LTR-NAS Operation Manual (PDF) LTR-PD-SD Operation Manual (PDF) LTR-PRS Operation Manual (PDF) LTO Series Usage Notes (PDF)
Tutorial	1	
Unpacking	1	

◆ Option

ITEM	QTY
LTR-NAS	NAS Storage Recording for LTR-200HS7 (Software plugin)
LTR-PD-SD	DVCPRO SD Codec for LTR-200HS7 (Software plugin)
LTR-PRS	Apple ProRes Codec for LTR-200HS7 (Software plugin)

Check

Check to ensure no damage has occurred during shipment. If damage has occurred, or items are missing, inform your supplier immediately.

Table of Contents

1. Prior to Starting.....	11
1-1. Welcome	11
1-2. Features	11
1-3. Concerning This Manual	11
1-4. Features	12
1-5. Operating Environment	12
1-6. Applicable LTO Tape	12
2. Preparations	13
2-1. Connections	13
2-2. Menu Control.....	13
2-3. Turning the Power On and Off	14
2-3-1. Turning the Power On.....	14
2-3-2. Turning the Power Off.....	15
2-4. Handling the LTO Tape Cartridges.....	16
2-4-1. Inserting and Mounting a Tape Cartridge	16
2-4-2. Unloading an LTO Tape Cartridge.....	17
2-4-3. Formatting an LTO Tape Cartridge.....	17
2-4-4. Copying an LTO Tape Cartridge.....	18
3. Recording and Playback	21
3-1. Recording.....	21
3-2. Playback.....	22
4. Operation Screens	23
4-1. Main Menu Screen	23
4-2. LTO Operations Screen	25
4-3. File List Screen.....	26
4-3-1. File Operation Screen	27
4-3-2. Search Filter Settings Screen	31
4-4. Timecode Display and Setting Screen (Recording).....	32
4-5. Timecode Display and Setting Screen (Playback)	32
4-6. Metadata Display and Setting Screen.....	33
4-7. Setting Screens	35
4-7-1. Recording Settings #1 Screen	35
4-7-2. Recording Settings #2 Screen	37
4-7-3. System Settings Screen.....	40
4-7-4. Input Signal Settings Screen.....	44
4-7-5. Save/Recall Settings Screen	45
4-8. File I/O Mode Screen	46
4-8-1. FTP Clients	47
4-9. Show All Files Screen	49
4-10. Maintenance Menu Screen	49
4-10-1. LTO Driver Maintenance Menu Screen	50
4-10-2. Saving the System Log.....	52
4-10-3. Interface and System Setting Menu Screen	53
4-10-4. Version Information Screen	61
4-10-5. Remote Support Screen	61
4-11. Remote Mode Screen	62
4-12. Scheduled Recording Screen	62
4-12-1. Setting / Editing Recording Schedules	63
4-12-2. Executing/Stopping Scheduled Recordings	64
4-13. OP-Atom to OP-1a Conversion (OP-Atom Ingest)	65
5. Panel Descriptions	66
5-1. Front Panel.....	66
5-1-1. Status Lights	67

5-1-2. Switches	67
5-1-3. Monitoring Screen	68
5-1-3-1. Decoding/Encoding Status	69
5-1-3-2. Start and End Timecode Display	70
5-1-4. Recording and Playback Control Area.....	71
5-1-5. Menu Control Area	72
5-1-6. Search Operation Area	73
5-2. Rear Panel	74
5-2-1. Digital Audio Input/Output Area	75
5-2-2. SDI Input/Output Area.....	75
5-2-3. LTC Input/Output Area.....	76
5-2-4. RS-422	76
5-2-5. GPI/ALARM.....	77
5-2-6. Power Supply Area	78
6. Troubleshooting.....	79
7. Restrictions	83
7-1. Recording	83
7-2. Playback.....	85
7-3. Miscellaneous.....	85
7-4. Supported LTO Tape	86
8. Specifications and Dimensions	87
8-1. Specifications	87
8-2. Proxy Video	89
8-2-1. H.264 File.....	89
8-2-2. Windows Media File	89
8-3. LTO-5 Basic Performance.....	90
8-4. LTO-6 Basic Performance.....	90
8-5. LTO-7 Basic Performance.....	90
8-6. External Dimensions	91
Appendix A. SCD Error Codes.....	A-1
A-1. Error Codes and Messages	A-2
A-2. Maintenance Mode	A-6
A-2-1. Entering Maintenance Mode.....	A-6
A-2-2. Exiting Maintenance Mode	A-6
A-3. Run LTO Drive Diagnostics	A-6
A-4. Test Head	A-7
A-5. Test LTO Cartridge & Media.....	A-7
A-6. Cleaning the LTO Drive Head	A-8
A-7. Write Performance Test.....	A-8
Appendix B. How to Reset BIOS.....	B-1
B-1. Opening BIOS Setup Menu	B-1
B-2. Setting Procedure	B-2
Appendix C. IBM LTFS.....	C-1

1. Prior to Starting

1-1. Welcome

Congratulations! By purchasing an LTR-200HS7 LTO Video Archiving Recorder you have entered the world of FOR-A and its many innovative products. Thank you for your patronage and we hope you will turn to FOR-A products again and again to satisfy your video and audio needs.

FOR-A provides a wide range of products, from basic support units to complex system controllers, which have been increasingly joined by products for computer video based systems. Whatever your needs, talk to your FOR-A representative. We will do our best to be of continuing service to you.

1-2. Features

This instruction manual describes how to operate the LTR-200HS7.

The LTR-200HS7 video archiving recorder contains, in addition to an LTO drive, MPEG-2, DNxHD, and AVC-Intra/DVCPRO codecs. By compressing HD/SD-SDI input signals into the selected codec, it can record them on LTO tapes as MXF files. It can also play the files recorded on the LTO tapes and output their data as HD/SD-SDI signals. It uses file input/output functions and FTP client software to read and write the files on the LTO tapes. Furthermore, using an IBM LTFS file system, the files recorded by this archiving system on LTO tapes can be read by other systems and the LTO tapes can be used as media for material or program changes.

1-3. Concerning This Manual

Please read this instruction manual carefully to ensure that you use the software correctly. After reading the manual, keep it in a safe place for future reference.

This instruction manual uses the following methods of expression.

- Characters printed in bold in the text indicate screen names and characters and words that are to be emphasized.
Ex.: If the [Power] button is pressed, a message as shown below appears.
- Characters in bold enclosed between square brackets [] in the text indicate the names of the unit's switches or buttons.
Ex.: [MENU] button, etc.
- Characters contained between quotation marks in the text indicate the names of on-screen selection items, manual chapters, or keyboard keys.
Example: "1-3. Features," etc.

- Text enclosed in double boxes consists of checkpoints or precautions.

Ex.:

It takes about 3 minutes for the unit to be operable after its power has been turned on.

- Text enclosed inside boxes formed using dotted lines consist of shortcuts or other reference items.

Ex.:

In recording mode, this **LTO Operations** screen can be displayed simply by pressing the [LTO] button.

1-4. Features

- Real-time recording of programs and materials as files on LTO tape cartridges
- MPEG-2, DNxHD, and AVC-Intra/DVCPRO codecs incorporated
- MXF OP-1a file format with extensive general-purpose capabilities supported
- LTO tape: The current IT industry standard storage media in use
- File reading and writing from PC the same as with regular external storage media enabled by IBM LTFS
- 3RU half-rack size dimensions
- LCD monitor for verifying material status and operational procedures provided
- External VTR control during recording supported using RS-422
- File input/output using gigabit Ethernet port
- Bar code reader or keyboard connection via USB 2.0/3.0 connector supported
- Linkup with MediaConcierge and other external products enabled

1-5. Operating Environment

The table below lists the equipment which is usually connected to the unit.

Equipment	Description
Video monitor	Displays the images output from SDI OUT.
USB keyboard	Used to input characters in the Metadata screen, etc. (For details, refer to “2-4-3. Formatting an LTO Tape Cartridge” and “4-6. Metadata Display and Setting Screen.”)
USB bar code reader (keyboard type)	Used to register LTO tape media ID bar codes. (For details, refer to “2-4-3. Formatting an LTO Tape Cartridge”.)
VTR	Used in VTR recording. (For details, refer to “5-1-3-2. Start and End Timecode Display.”)
PC	This is used to read and write files on LTO tapes directly in File I/O mode. (For details, refer to “4-8. File I/O Mode Screen.”)

* Provide an LTO cleaning cartridge that supports the LTO-7 drive format. (The LTO drive automatically determines whether cleaning is necessary.)

* If a power outage occurs during recording, LTO tape cartridge recovery may take time or recorded files may be lost. Use of a UPS (Uninterruptible Power Supply) is recommended in critical environments.

1-6. Applicable LTO Tape

LTO tapes as shown in the table below are applicable to LTR-200HS7.

Type	Reading	Writing	Formatting
LTO-5	✓	-	-
LTO-6	✓	✓	✓
LTO-7	✓	✓	✓

- When data are written in LTO-5, the file is not saved. Also, file moving and deletion cannot be done.
- WORM cartridge is not applicable.

2. Preparations

2-1. Connections

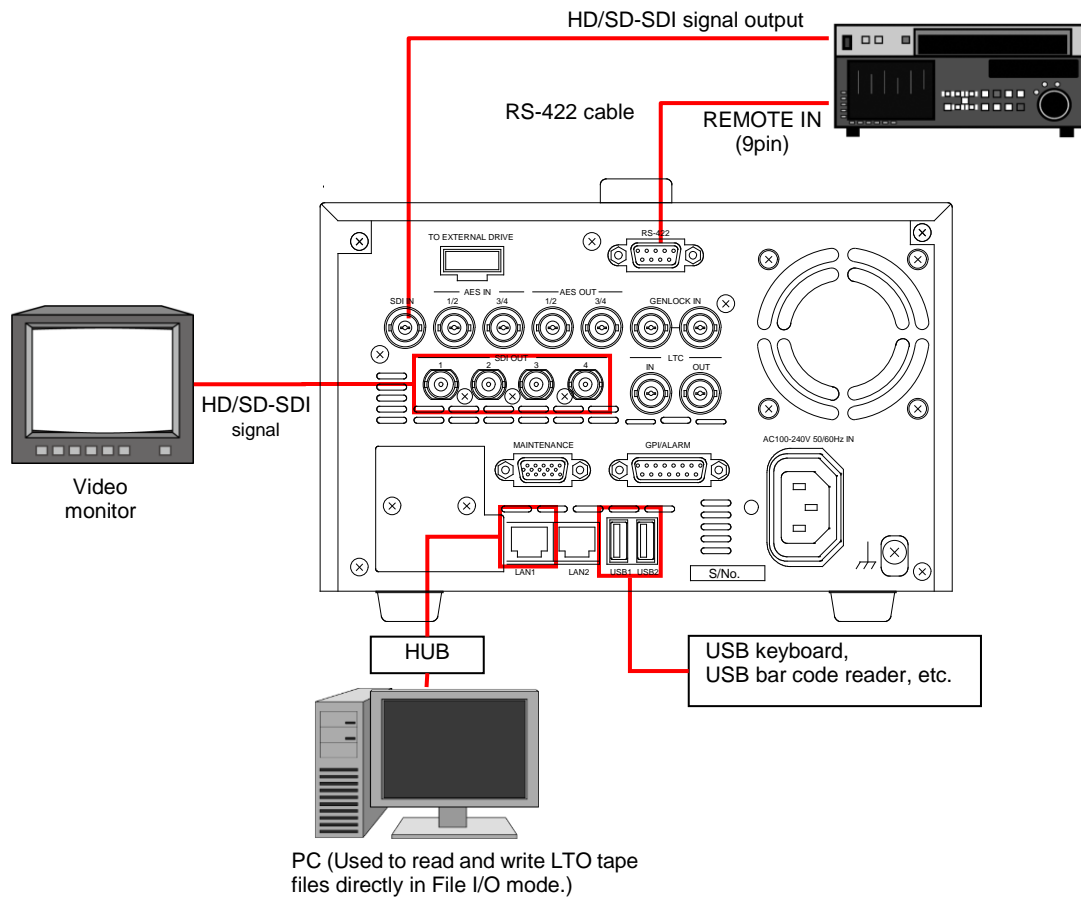

- The USB keyboard and USB bar code reader can also be connected to the front panel USB connectors.
- An RS-422 cable is used to automatically control the VTR from the LTR recorder when recording from the VTR.

2-2. Menu Control

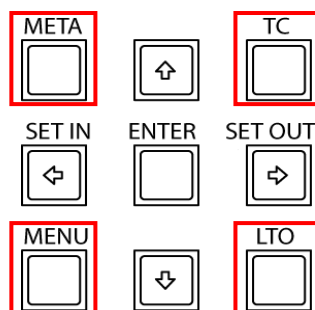

All screens can be displayed from the **Main Menu** screen which appears when the **[MENU]** button is pressed. For details, refer to “4-1. Main Menu Screen.”

The **[META]**, **[TC]** and **[LTO]** shortcut buttons display the **Metadata** screen, **Timecode** screen and **LTO Operations** screen, respectively. For details, refer to “5-1-5. Menu Control Area.”

2-3. Turning the Power On and Off

2-3-1. Turning the Power On

Press the power switch to turn on the LTR recorder. The Power LED will light up green and the message "Please wait..." will appear on the LCD monitor screen.

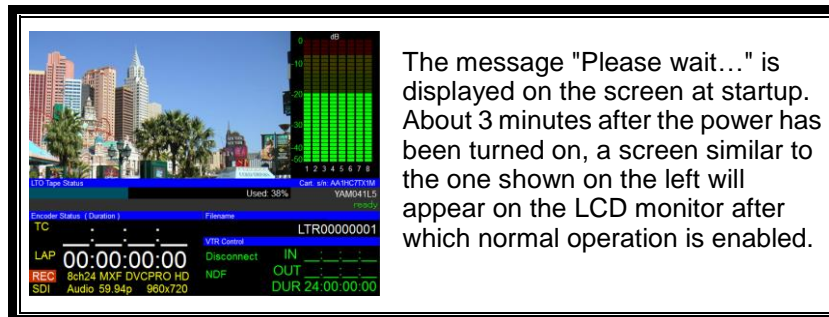
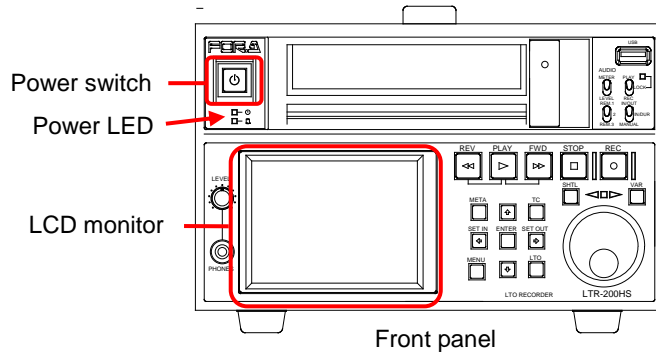

2-3-2. Turning the Power Off

Unplugging the power cable without first shutting down operation may cause malfunction, such as a mounting error.

Press the **[Power] button** on the front panel to shut down the system before unplugging.

The message shown in the figure below is displayed when the **[Power] button** on the front panel is pressed. Press the **[Power] button** again to shut down the system.

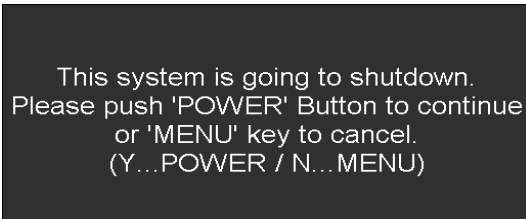

This system is going to shutdown.
Please push 'POWER' Button to continue
or 'MENU' key to cancel.
(Y...POWER / N...MENU)

It will take several minutes for the power to turn off.
The message "Please wait..." is displayed on the LCD screen during shutdown.
Unplugging the power cable during shutdown can cause trouble. Therefore, first check that the Power LED has gone off, before unplugging the power cable.

2-4. Handling the LTO Tape Cartridges

2-4-1. Inserting and Mounting a Tape Cartridge

Before inserting an LTO tape cartridge, be sure that the Monitoring screen is displayed on the LCD monitor. LTO tape cartridge that is inserted immediately after powering on may not mount properly.

There are two methods for mounting LTO cartridge tapes: auto-mounting and manual-mounting. Refer to section 4-10-1. "LTO Driver Maintenance Menu Screen" for more details.

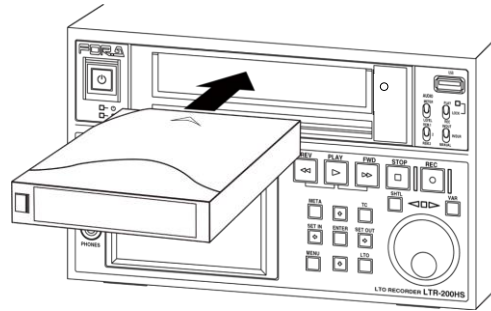

◆ Automatic Tape Mounting

- (1) Insert an LTO tape cartridge, pointing in the direction shown in the figure, horizontally.
- (2) The LTO tape will automatically mount. (*1.)

◆ Tape Mounting using the Menu

- (1) With the LTO tape cartridge pointing in the direction shown in the figure, insert it horizontally.
- (2) Press the **[MENU]** button to open the **Main Menu** screen.
- (3) Select "**LTO Operations**" to open the **LTO Operations** screen.
- (4) When the **LTO Operations** screen has appeared, select "**Mount LTO tape**" to mount a tape. (*2)

*1 Note that tapes cannot be automatically mounted if a menu screen other than **Monitoring** (startup screen) as shown below has been appears.



*2 It takes 30 seconds to a minute for mounting to be completed. It may take several minutes if there are many files.

2-4-2. Unloading an LTO Tape Cartridge

- (1) Press the [MENU] button to open the **Main Menu** screen.
- (2) Select “**LTO Operations**” to open the **LTO Operations** screen.
- (3) When the **LTO Operations** screen has appeared, select “**Eject LTO tape**”.
- (4) The “**Do you unmount the tape?**” message appears. Press the [ENTER] button to unmount the tape.
- (5) After the LTO tape has been unmounted, it is ejected automatically.

- LTO tape cartridges are designed in such a way that they cannot be unloaded unless they are reversed all the way to the beginning. As a result, it may take about 3 minutes for a tape cartridge to eject.
- It may take about 20 seconds for a tape cartridge to eject after a tape is rewound to the beginning.

2-4-3. Formatting an LTO Tape Cartridge

An LTFS file system is utilized in this unit and so the LTO tape cartridge must be formatted in the LTFS format before they are use.

Eight-character string LTO barcode IDs ending with an “L6” or “L7,” and called “Media IDs” are printed on tape labels and used to identify LTO tapes in LTR Series devices. Use a unique media ID for each LTO tape.

LTO barcode labels are unnecessary for LTR units, but required for auto-loading on LTO tape autoloaders.

- (1) Press the [MENU] button to open the **Main Menu** screen.
- (2) Select “**LTO Operations**” to open the **LTO Operations** screen.
- (3) Select “**Format LTO tape.**”
- (4) The “**Please enter ‘Media ID’**” message appears. Input the bar code ID of the LTO tape cartridge using a USB bar code reader or USB keyboard. (Input the first six characters of Media ID. Suffixes such as “Lx” are not needed.) If a USB keyboard or USB bar code reader is not connected, simply press the [ENTER] button.
- (5) The “**Do you carry out a format of the tape?**” message now appears. Press the [ENTER] button to format the tape.

When an LTO tape cartridge is formatted, all of its data will be erased. When formatting is complete, the LTO tape mounts automatically and the media ID is written.

2-4-4. Copying an LTO Tape Cartridge

Before copying an LTO tape cartridge, format a tape in LTFS on this unit. Unformatted tapes cannot be used for copying.

- (1) Press the **[MENU]** button to open the **Main Menu** screen.
- (2) Select **“LTO Operations”** to open the **LTO Operations** menu screen.
- (3) Select **“Copy LTO tape (single drive).”**
- (4) When the **“Copy LTO tape (single drive)...”** message (see below) appears, press **[ENTER]**. *

* If an LTO tape cartridge is already mounted when pressing **[ENTER]**, the LTO tape will automatically unmount and eject.

Copy LTO tape (single drive) copies files of one or few LTO tape(s) to another LTO tape using cache HDD. Please prepare FORMATTED or enough space LTO tape as destination. You can make several copies from a source.
Push 'ENTER' key to proceed or 'MENU' key to cancel.

- (5) When the **“Please insert ‘Write Protected...”** message (see below left) appears, insert a write-protected tape cartridge (see below right) and press **[ENTER]**.

Please insert 'Write Protected' source LTO tape.
Please push 'ENTER' key to proceed or 'MENU' key to cancel.
(Y..ENTER/N...MENU)

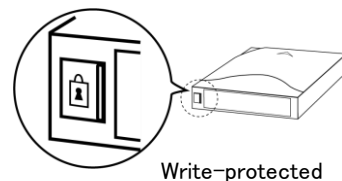

(6) File copying of the LTO tape cartridge automatically starts. *

* The larger the data in the tape, the longer it will take to copy. A file name is displayed during copying.

To Cancel Copying:

1. Press the **[MENU]** button while either of the following messages is displayed.

Verifying files in the source LTO tape.

Please wait...It may take few hours.
packageinfo.xml
Push **[MENU]** key to interrupt.

Copying files in the source
LTO tape to cache...

Please wait...It may take few hours.
LTR00000001.mxf
Push **[MENU]** key to interrupt.

2. When the following message appears, press the **[ENTER]** button to cancel copying. Pressing the **[MENU]** button resumes copying.

The copy process is going to abort.
Please push 'ENTER' key to abort or
'MENU' key to continue.
(Y...ENTER / N...MENU)

(7) Once file copying is finished, the LTO tape cartridge automatically unmounts and ejects.

(8) When the “**Please insert destination...**” message (see below left) appears, insert an LTFS-formatted writable tape cartridge (see below right) and press **[ENTER]**.

Please insert destination LTO tape to
write.
Please push 'ENTER' key to proceed or
'MENU' key to cancel.
(Y...ENTER / N...MENU)

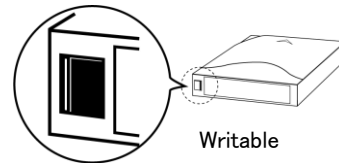

(9) The data copied in Step (6) is automatically written to the LTO tape. (*)

* Files with the **same GroupID and FileID** already exist in the destination tape, they are not overwritten. Media ID cannot be displayed for copied files. A file name is displayed during writing.

To Cancel Writing:

1. Press the [MENU] button while the following message is displayed.

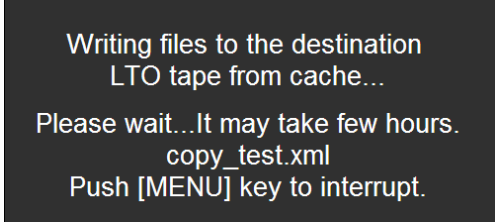

```
Writing files to the destination
LTO tape from cache...

Please wait...It may take few hours.
copy_test.xml
Push [MENU] key to interrupt.
```

2. When the "The copy process is going..." message appears, press the [ENTER] button to cancel writing. Pressing the [MENU] button resumes writing.

(10) Once writing is finished, the message "Writing file is done..." (see below) appears.

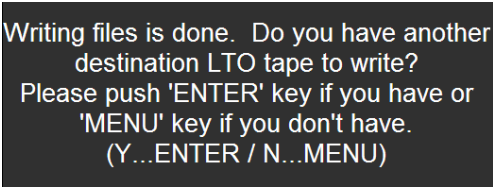

```
Writing files is done. Do you have another
destination LTO tape to write?
Please push 'ENTER' key if you have or
'MENU' key if you don't have.
(Y...ENTER / N...MENU)
```

A. To write to another LTO tape:

Press [ENTER] and repeat Steps (8) to (10).

B. To finish writing

Press [MENU].

Writing may not complete in a single process due to LTO tape cartridge condition. In such case, press [MENU] and copy the remaining files repeating from step (5).

(11) The message "Finished copying..." will appear. Press [ENTER] or [MENU] to complete the process. The LTO tape will be automatically ejected.

3. Recording and Playback

Use **LTO-6 or LTO-7 tape cartridges** with the LTR-200HS7 unit. Also use LTO tape cartridges that have been formatted by the same unit.

To record and play back data, the LTO tape cartridge must be mounted. For details on how to insert and mount tapes, refer to "2-4-1. Inserting and Mounting a Tape Cartridge."

A pop-up message will appear asking you to mount an LTO tape when you try to record files while the LTO tape is not mounted. Click **[ENTER]** to mount the LTO tape.

3-1. Recording

- (1) Set the OPERATION switch (upper right, front panel) to **REC** (bottom position) to enter Recording mode. (Refer to "5-1-2. Switches" for details on the switches.)

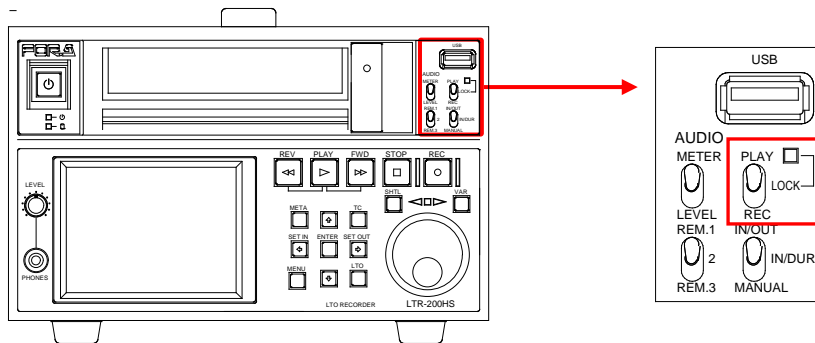

- (2) Set the REC MODE switch to **MANUAL** (bottom position). (For details on the switches, refer to "5-1-2. Switches.")

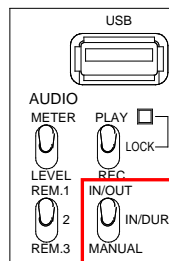

- (3) Set the profile of the file to be recorded. (For details on profiles, refer to "4-7-2. Recording Settings #2 Screen.")

- (4) Press the **[PLAY]** button while holding down the **[REC]** button to start recording. While recording is in progress, the **[REC]** button lights red.

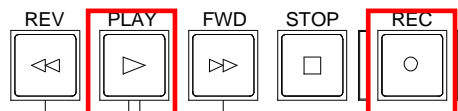

- (5) Press the **[STOP]** button to stop recording.

- * If a short recording DURATION has been set, recording will stop at the set time without pressing the **[STOP]** button.
- * To record while the VTR is being controlled automatically, refer to "5-1-3-2. Start and End Timecode Display" and "4-4 Time Code Display and Setting Screen (Recording)."

3-2. Playback

- (1) Set the OPERATION switch (upper right, front panel) to **PLAY** (top position). (For details on the switches, refer to "5-1-2. Switches.")

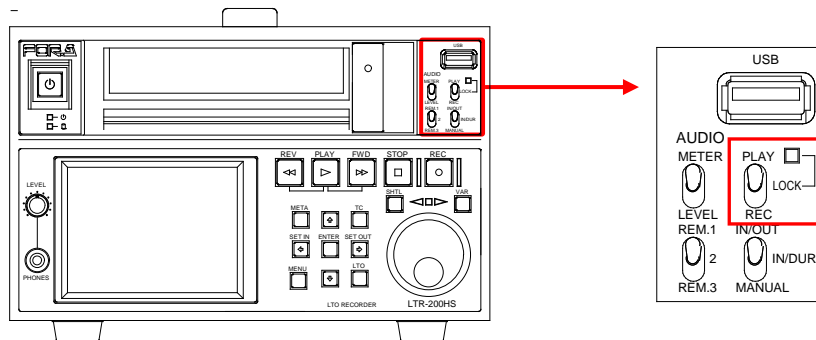

- (2) Display the file list screen by selecting "**Main Menu > File List.**" (For details on the **File List** screen, refer to "4-3. File List Screen.")

	LTR20140912-133435 [DUR 00:00:30:00 NDF] DNxHD 115 720/50p	DNxHD
	LTR20140912-133612 [DUR 00:00:30:00 NDF] DNxHD 175 720/50p	DNxHD
	LTR20140912-134428 [DUR 00:00:30:00 NDF] DNxHD 220 720/59p	DNxHD
	LTR20140912-151514 [DUR 00:06:26:26 NDF] DNxHD 145 720/59p	DNxHD
	LTR20140912-152536 [DUR 00:00:30:00 NDF] DVCPRO 1080/59i	DVCPRO

ShowThumbnail: [] FileOperation: [TC] SearchFilter: [META]

- (3) When the **File List** screen has appeared, press the [↑] button or [↓] button or use the jog dial to select the file, then press the [ENTER] or [PLAY] button.

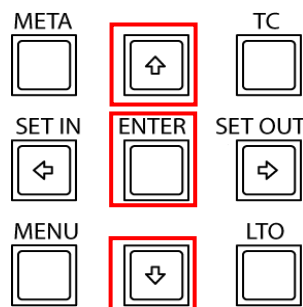

- (4) Files can be played back by operating the [PLAY] and [REV] buttons, jog dial and shuttle ring. (For details on the buttons, jog dial and shuttle ring, refer to "5-1-4. Recording and Playback Control Area" and "5-1-6. Search Operation Area.")

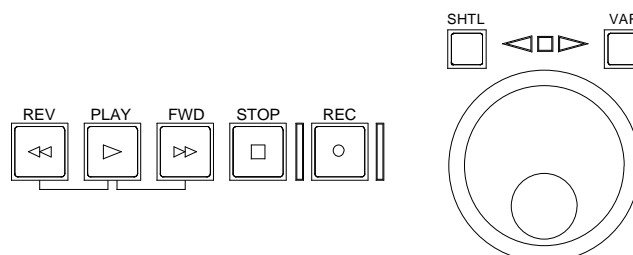

- (5) Press the [STOP] button to stop playback. When a file has been played to its end, playback stops automatically.

4. Operation Screens

4-1. Main Menu Screen

The **Main Menu** screen, such as the one shown below, is displayed when the **[MENU]** button (refer to “5-1-5. Menu Control Area”) in the menu control area is pressed.

Use the **[↑]**, **[↓]**, **[→]**, and **[←]** buttons or jog dial to select menu items, and **ENTER** the selected items by pressing the **[ENTER]** or **[PLAY]** button. When the **[MENU]** button is pressed again, the **Monitoring** screen is restored.

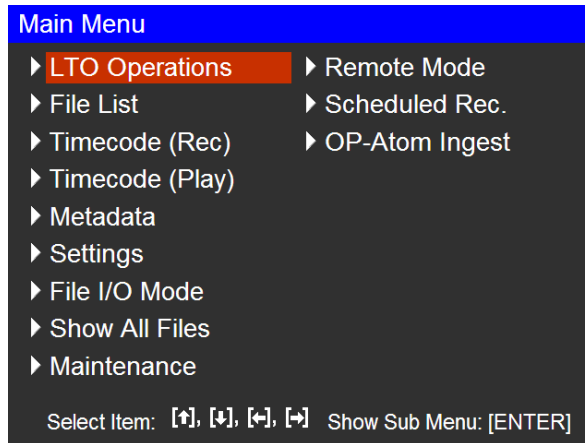

◆ Menu List

Level 1	Level 2	Level 3	Level 4	Reference
LTO Operations	Mount LTO tape Eject LTO tape Format LTO tape Recover LTO tape Copy LTO tape (single drive)			4-2
File List	Thumbnail File Info Meta Info	File Operation	Info Erase cache Delete Copy to tape Partial Retrieve	4-3
			Search Filter Settings	
Timecode (Rec)	IN Point OUT Point Duration Start Timecode TC Format			4-4
Timecode (Play)	TopTC EndTC Duration Cached Duration Go to Jump Distance			4-5
Metadata	MedialD GroupID ContentID FileID Title Synopsis Rights			4-6
Settings	Recording Settings #1	Audio level & mapping(Rec) Rec control mode Naming rule of MXF file Prefix Embed DMS-1 Metadata in MXF file Write on LTO tape at ingest time Max writable space		4-7-1

(Continued on next page)

Level 1	Level 2	Level 3	Level 4	Reference
Settings	Recording Settings #2	Encoder profile Timecode in file Proxy output		4-7-2
		Proxy settings	Proxy Video TC Option TC Size TC Position	
	System Settings	Audio level & mapping(Play) Audio reference level Reference input format H Phase V Phase Timecode super settings Show TC on screen Back color		4-7-3
	Input Signal Settings	Signal status Video format Audio source LTC source TC jam-sync		4-7-4
	Save/Recall Settings	Save the current settings as #1 Save the current settings as #2 Save the current settings as #3 Save the current settings as #4 Recall the current settings from #1 Recall the current settings from #2 Recall the current settings from #3 Recall the current settings from #4 Return to the factory default settings		4-7-5
File I/O Mode				4-8
Show All Files				4-9
Maintenance	Shutdown			4-10
	Restart GUI			4-10
	LTO driver Maintenance	Auto mount LTO tape Force unmount LTO tape Show LTO tape condition Save LTO drive dump Repair slow mounting LTO tape		4-10-1
	Error log			4-10
	Save System Log			4-10-2
	Interface and System Setting	Change IP address GPI settings Change date & time Firmware update FTP Settings VTR control settings		4-10-3
		Network output settings	Proxy output settings NAS output Settings	
		Cache mode settings		
	Version			4-10-4
	Remote support			4-10-5
Option			4-10	
Remote Mode				4-11
Scheduled Rec.	Scheduled Recording	Scheduled Recording Setting		4-12
OP-Atom Ingest	Thumbnail File Info Meta Info			4-13

4-2. LTO Operations Screen

When **LTO Operations** is selected in the **Main Menu** screen, the **LTO Operations** screen such as the one shown below is displayed.

Use the [↑] and [↓] buttons or the jog dial to select menu items, and enter the selected items by pressing the [ENTER] or [PLAY] button. When the [MENU] or [←] button is pressed, the **Main Menu** screen is restored.

In recording mode, the **LTO Operations** screen can be displayed simply by pressing the [LTO] button. In playback mode, the **File List** screen is displayed after the [LTO] button is pressed, and when the [→] button is pressed, the **LTO Operations** screen is displayed.

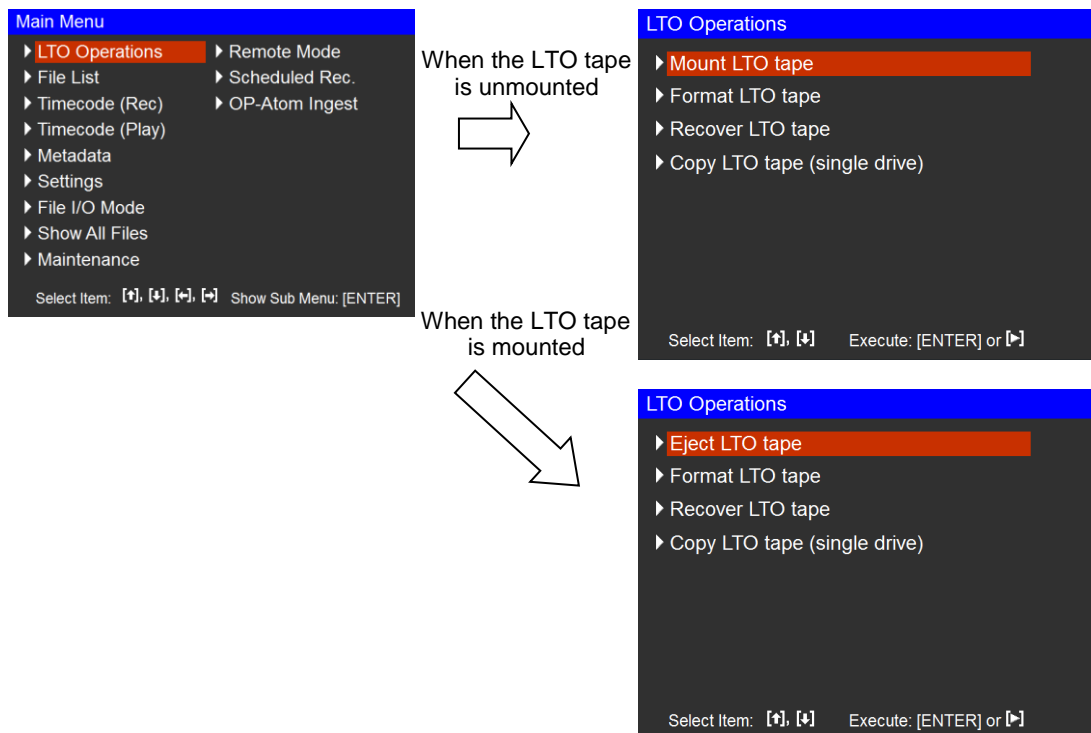

Item	Description
Mount LTO tape	Mounts the LTO tape. If a tape is already mounted, " Eject LTO tape " will be displayed.
Eject LTO tape	Unmounts and ejects the LTO tape. If no tape is mounted, " Mount LTO tape " will be displayed.
Format LTO tape	Formats the LTO tape in the LTFS format to enable the tape to be used. For details, refer to "2-4-3. Formatting an LTO Tape Cartridge."
Recover LTO tape (*1)	Recovers the LTO tape if its file information can be recovered.
Copy LTO tape (single drive)	Copies an LTO tape. Refer to "2-4-4. Copying an LTO Tape Cartridge" for details.

*1 This operation is used when the power has been turned off accidentally, for instance, before a tape unmount was completed and is not used during normal operation. It may take 2 or more hours to recover tape data from a power failure. During the recovery process, the LTO tape may be ejected or [6] (SCD error code) may blink on the panel. Note that, in some cases, tape content may not be successfully recovered.

If mounting takes longer than before after tape data has been recovered, execute "Repair slow mounting LTO tape" in the LTO Driver Maintenance Menu Screen (see 4-10-1.).

4-3. File List Screen

When **File List** is selected in the **Main Menu** screen, a file list screen such as the one shown below is displayed.

Use the [↑] and [↓] buttons or the jog dial to select files, and play back^(*) the files by pressing the [ENTER] or [PLAY] button. When the [MENU] button is pressed, operation returns to the **Main Menu** screen. When the [→] button is pressed, operation transfers to the **LTO Operations** screen. Recorded files are listed according to ascending order of GroupID / File ID. (To change the display order, see "4-10-3. Interface and System Setting Menu Screen ◆Cache mode settings"). The file background color in the list varies depending on the recording state. Refer to "Background Color," further below on this page for details.

- The **File List** screen can be displayed simply by pressing the [LTO] button in playback mode.
- Thumbnails can be magnified by clicking [←] after selecting files. Clicking [←] again returns the screen to **File List**.
- When **File List** is opened, the last played file appears as the selected file (indicated by a red square).

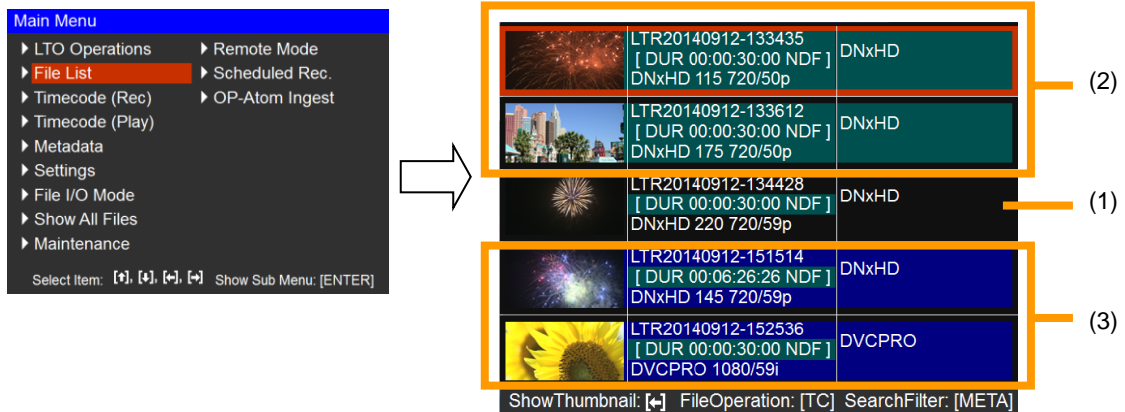

Item	Description
Thumbnail	Displays thumbnails.
File Info	First line: File ID (file name) Second line: Duration Third line: Recording format
Meta Info	Displays set titles in the Title box in the Metadata screen (For details, refer to "4-6. Metadata Display and Setting Screen".)

◆ Background Color

The background color of files listed in the File List vary according to their "**Write on LTO tape at ingest time**" setting^(*) at the time of recording.

BG Color	"Write on..." setting ^(*)	Description
(1) Black	-	If the cache file has not been stored to the internal hard disk drive, the background color of the file turns black. When the file with black background is opened in playback mode, a cache copy is created and stored on the internal hard disk drive, and the background color of the file turns green.
(2) Green	YES	The cache file has been stored to the internal hard disk drive, but the file data cannot be written to the LTO tape by copying the cache file. Executing "Erase cache" ^(*) erases the cache file and the background color of the file turns black.

(Continued on next page)

BG Color	"Write on..." setting (*1)	Description
(3) Blue	NO or YES+1copy	<p>The cache file has been stored to the internal hard disk drive, and the file data can be written to the LTO tape by copying the cache file.</p> <p>To Write to LTO tape: Execute "Copy to tape" (*2).</p> <p>To Delete the cache without writing to LTO tape: Execute "Delete" (*2).</p> <p>To Play the file: The file can be played back in playback mode.</p>

*1 Refer to "4-7-1. Recording Settings #1 Screen" for details on "Write on LTO tape at ingest time."

*2 Refer to "4-3-1. File Operation Screen."

When mounting or unmounting LTO tapes while files with blue background color are displayed in the File List, a dialog as shown at right will appear asking if you want to write files on the internal hard disk drive to the LTO tape. (*1)

Press [ENTER] to write files to the tape.
Or press [MENU] to cancel writing.

Files with blue background color have cached copies on the internal hard disk drive and the cached copies remain in the hard disk unless writing or deleting is executed. These files can therefore be played back in playback mode without mounting LTO tapes.

*1 When files were recorded under the "YES+1copy" setting, this dialog will appear although the files have been already written to the LTO tape.

The file not written on the LTO tape remains in the cache.
Do you write it on the LTO tape?
Please push 'ENTER' key or 'MENU' key to cancel.
(Y..ENTER / N..MENU)

4-3-1. File Operation Screen

The **File Operation** screen is displayed when the [TC] button is pressed in the **File List** screen while a file is selected (indicated by a red square). When the [MENU] or [←] button is pressed after selecting an item in the menu with the [↑] and [↓] buttons or jog dial, operation returns to the **File List** screen.

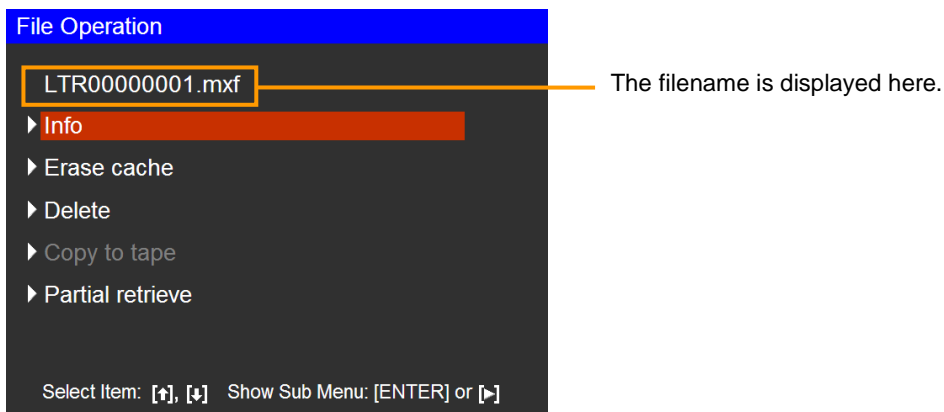

Item	Description
Info	Displays the File Information screen. Refer to "File information screen" below.
Erase cache	Erases files that have been copied onto the internal hard disk. (The file being played back cannot be erased.)

(Continued on next page)

Item	Description
Delete	<p>Deletes^(*1) movie files on the LTO tape. Deletes files on the hard disk indicated in blue in the list. When Delete is selected, a dialog box asking the user whether to proceed with the deletion is displayed. To delete a file, press the [ENTER] button; to cancel the deletion, press the [MENU] button.</p> <div style="border: 1px solid black; padding: 5px; margin: 10px 0;"> <p>Note that the LTO media is writable, but cannot be re-written, nor physically overwritten by deleting data. Deleting a file only removes its entry from the files system, making it invisible, and does not free up space.</p> </div>
Copy to tape ^(*2)	<p>Writes cached copies on the internal hard disk drive to the LTO tape. When "Copy to tape" is selected, a dialog box will appear. Press [ENTER] to write copies to the LTO tape. Or, press [MENU] to cancel writing.</p>
Partial retrieve ^(*3)	<p>Displays the Partial Retrieve screen, which allows new MXF files to be created by copying parts of MXF files. Refer to "Partial Retrieve screen" below in this section.</p>

*1 The files cannot be deleted while they are played back.

*2 This process can be executed if a file with blue back color is displayed in the File List.

*3 "Partial retrieve" grayed out on the screen indicates that either the MXF file has not been written to the LTO tape or that it was written to the LTO tape without using the LTR recorder. In the former case, perform "Copy to tape" and then "Partial retrieve."

◆ File Information Screen

File details are shown in the **File Information** screen.

Operation returns to the **File Operation** screen when the **[ENTER]**, **[MENU]**, **[PLAY]**, **[TC]**, **[LTO]**, or **[←]** button is pressed.

File Information

Date Modified: 2011/01/05 15:43:17

Folder: FOR-A\HD_5994i_50M\data

Filename: HD_5994i_50M.mxf

MediaID: GroupID: FOR-A

ContentID: LTR0002 FileID: HD_5994i_50M.mxf

Title: Fishes in the sea

Synopsis: For demonstration purpose only.
Source : HDCAM
Reported by LTR-100HS

Rights: FOR-A

Profile: MXFOP1a MPEG2 LongGOP HD422 50Mbps 1080/59.94i

Back File Operation Menu: [ENTER] or [MENU]

Item	Description
Date Modified	Date/time of file modification
Folder	Storage location of file
Filename	File name
MediaID*	Bar code ID of LTO tape
GroupID*	Group name
ContentID*	Control number of contents
FileID*	File name
Title*	Title
Synopsis*	Synopsis
Rights*	Information concerning rights
Profile	Recording format

* Displayed for these items are the settings selected in the **Metadata** screen. (For details on the **Metadata** screen settings, refer to "4-6. Metadata Display and Setting Screen.")

◆ Partial Retrieve Screen

The **Partial Retrieve** screen allows you to create new MXF files on the internal hard disk drive by extracting sections from MXF files on the LTO tape.* Files recorded in the AVC-Intra/DVCPRO OP-1a format will be converted to OP-Atom format.

The new MXF files can be downloaded using the File I/O function (FTP).

Use the [←] and [→] buttons to select an item, and use the [↑] and [↓] buttons (Holding [↑] or [↓] pressed speeds up the change.) and jog dial to change values. (Holding down the [↑] or [↓] button displays values one after another.) When the [MENU] button is pressed after performing a process with the [ENTER] or [PLAY] button, operation returns to the **File List** screen.

* Up to **3 hours** of video clips can be retrieved.

- Some playout devices and software may produce noise in the first 2 frames of partially retrieved MXF files or retrieve more frames than specified when the original MXF file is processed by HD MPEG-2 codec due to the MPEG-2 Long GOP characteristics.
- MXF files, not generated by LTR recorders, are not guaranteed to be partially retrieved.
- Note that the LTR recorder cannot be directly linked with an NLE or other systems in some cases.

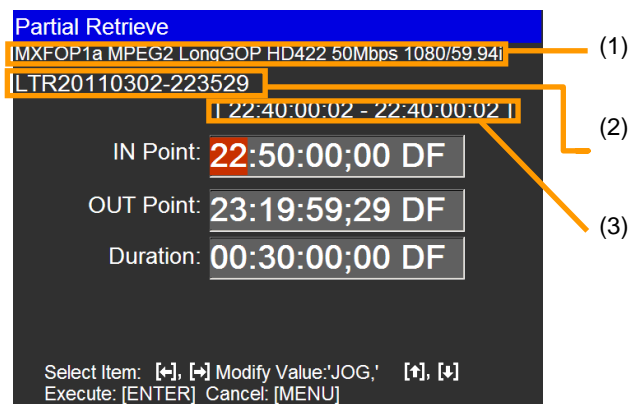

Item	Description
(1)	Displays the recording format of the Partial Retrieve file.
(2)	Displays the name of the file of the Partial Retrieve file.
(3)	Displays the start and end time codes of the Partial Retrieve file.

◆ **To perform partial retrieval:**

- (1) When the **Partial Retrieve** screen appears, set IN Point, OUT Point and Duration values referring to the start and end time codes. Then press [ENTER] to perform the partial retrieval.
- (2) A dialog box as shown below will appear during the process. To cancel the process, press [MENU].

Partial Retrieve
Push [MENU] key to cancel.

450/1800 frames retrieved.

Please wait until processing ends.
Push 'MENU' key to cancel.
OP-1a to OP-Atom Converting... 37%

To Cancel the Conversion process:

1. Press the [MENU] button to pause the process while the dialog is displayed.
2. Press the [ENTER] button to cancel the conversion.
Pressing [MENU] at this time resume the conversion process.

Partial retrieving now.
Do you want to cancel it?
Push 'ENTER' key to cancel or 'MENU' key
to continue
(Y...ENTER / N...MENU)

Convert OP-1a to OP-Atom now. Do you
want to cancel it?
Please push 'ENTER' key to cancel or
'MENU' key to continue
(Y...ENTER / N...MENU)

- (3) When the conversion has completed, the converted file is stored in the internal hard disk drive. To use the file, download **"/output/partial.mxf^(*1)"** or the **"/output/CONTENTS/"^(*1)** folder from the hard drive via FTP ^(*2).

- *1 Note that **partial.mxf** files and **CONTENTS** folders are overwritten each time a conversion is performed. To perform partial retrieval continuously, repeat the conversion and download steps.
- *2 Access the LTR recorder using user account **"metadata"**. Refer to "4-8. File I/O Mode Screen" for details on downloading files thorough ftp.

4-3-2. Search Filter Settings Screen

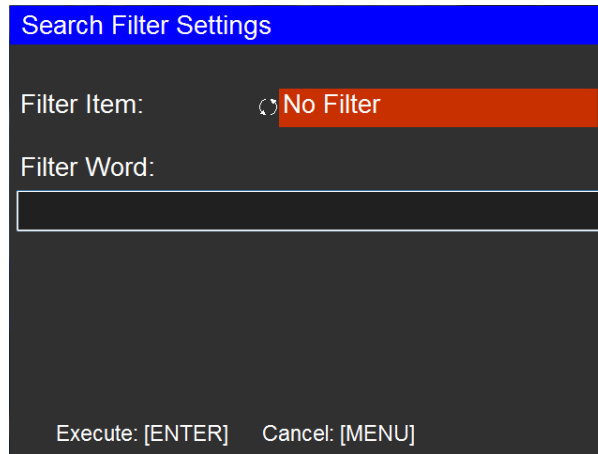

Press **[META]** button in

The **Search Filter Settings** screen is displayed when the **[META]** button is pressed in the **File List** screen. Use the jog dial to select an item in **Filter Item**. Input a **Filter Word**. A USB keyboard is required to input a **Filter Word**. Press **[Enter]** button and the files that contain the keyword in the names are only listed in the file list. When the **[MENU]** button is pressed, operation returns to the **File List** screen.



Item	Description	
Filter Item	Sets the metadata item to be searched.	
	No Filter	Does not search.
	FileID	Search by file ID.
	GroupID	Search by group ID.
	ContentsID	Search by contents ID.
	Title	Search by title.
	Synopsis	Search by synopsis.
	Rights	Search by rights.
	Profile	Search by recording codec.
All items	Search all metadata items.	
Filter Word	Sets a keyword to search.	

When Search is enabled, the SearchFilter column in the lower right corner in the File List screen is indicated in green. To disable the search, set **Filter Item** in the **Search Filter Settings** screen to No Filter.

	LTR20140912-133435 [DUR 00:00:30:00 NDF] DNxHD 115 720/50p	DNxHD
	LTR20140912-133612 [DUR 00:00:30:00 NDF] DNxHD 175 720/50p	DNxHD
ShowThumbnail: [←] FileOperation: [TC		SearchFilter: [META]

4-4. Timecode Display and Setting Screen (Recording)

When **Timecode (Rec)** is selected in the **Main Menu** screen, a time code screen such as the one shown below is displayed. The time codes for recording are set and checked on this screen. Use the [←] and [→] buttons to select an item, and use the [↑] and [↓] buttons and jog dial to change values. (Holding down the [↑] or [↓] button displays values one after another.) Select the **TC format** using the shuttle ring. Enter selections using the [ENTER] or [PLAY] button. When the [MENU] or [TC] button is pressed again, the **Monitoring** screen is restored. Hold down the [→] button to transfer to the **Timecode (Play)** screen.

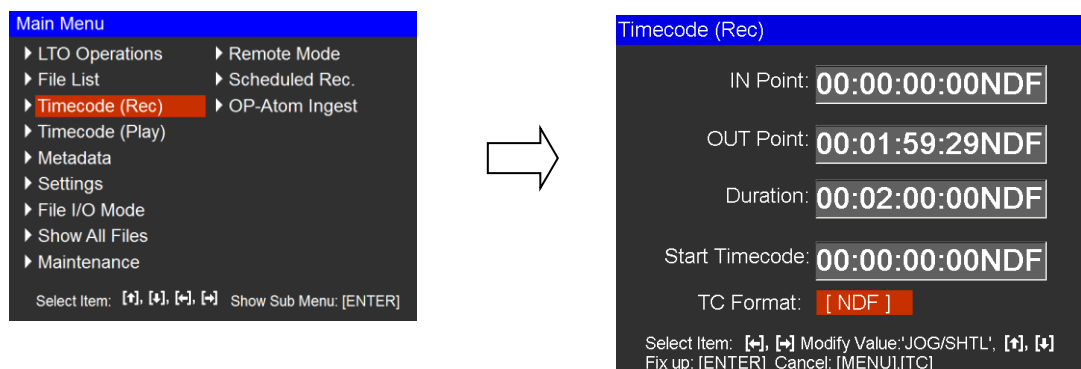

Item	Description
IN Point	Sets the recording start TC.
OUT Point	Sets the recording stop TC.
Duration	Sets the recording duration.
Start Timecode(*1)	Specifies the start TC of the recorded file.
TC Format	Select this to specify DF or NDF with the 59.94i or 59.94p format.

*1 Takes effect when Preset TC has been selected as the Timecode under the file setting. (For details, refer to "4-7-2. Recording Setting #2 Screen.")

4-5. Timecode Display and Setting Screen (Playback)

When "**Timecode (Play)**" is selected in the **Main Menu** screen, a time code screen such as the one shown below is displayed and is used mainly to check the time code information of the current playback file.

Use the [←] and [→] buttons to select an item, and use the [↑] and [↓] buttons and jog dial to change values (Hold down the [↑] and [↓] buttons to continually change values). Select the **TC/CTL Format** for **Go to** using the shuttle ring. Enter selections using the [ENTER] or [PLAY] button. When the [MENU] or [TC] button is pressed, operation returns to the **Main Menu** screen. Hold down the [←] button to transfer to the **Timecode (Rec)** screen.

* The DF or NDF setting at 59.94i depends on the setting of the currently open MXF file.

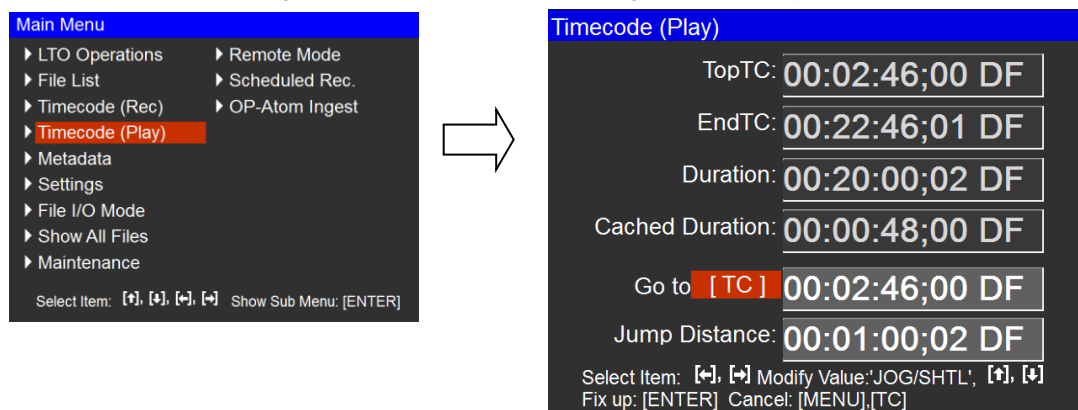

Item	Description
TopTC*	Displays the start TC of the currently open file.
EndTC*	Displays the end TC of the currently open file.
Duration*	Displays the playback duration of the currently open file.
Cached Duration*	Displays the cached duration of the currently open file on the internal hard disk.
Go to	[TC] and [CTL] can be selected. When [CTL] is selected, the file start point is interpreted as the value which is considered to be 00:00:00:00. Enter a timecode value and press [ENTER] to play files from the specified timecode. If specified timecode values are not included in cached data, files will be played back while being partially retrieved.
Jump Distance	Sets the time for each jump using the [←] and [→] buttons on the front panel. The default time is 1 minute.

* These items cannot be changed.

4-6. Metadata Display and Setting Screen

When **Metadata** is selected in the **Main Menu** screen, a **Metadata** screen such as the one shown below is displayed. In recording mode, the metadata (*1) to be recorded during recording is set on this screen. In playback mode, the metadata of the currently open file is displayed and can be modified.

A USB keyboard is required to perform these settings.

The “**Tab**” key is used to move from one item to the next. The [ENTER] or [PLAY] button is used to enter the items selected. The [MENU] button is used to cancel the items selected.

*1 Leaving metadata fields blank does not pose any problems for recording. **FileID** is generated automatically. If **GroupID** is blank, the folder name will be “generic”.

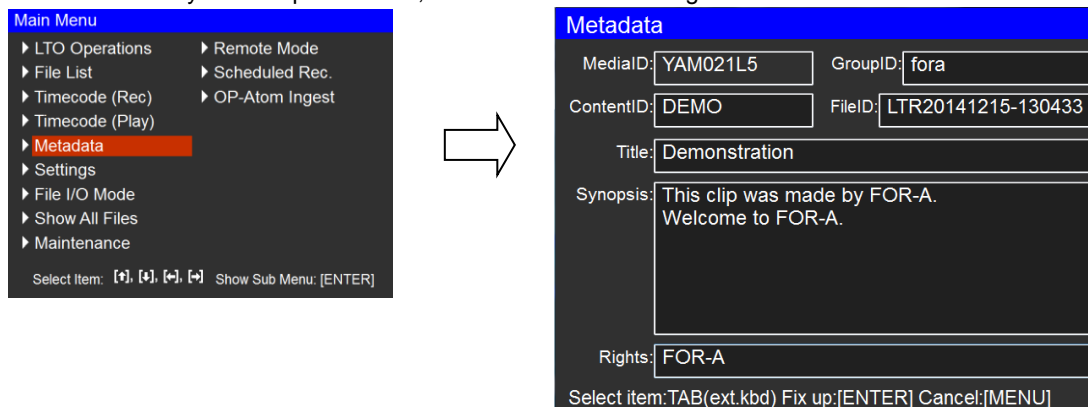

Item	Description
MediaID	Displays the bar code IDs of the LTO tapes. The bar code ID that has been input during formatting is displayed, so MediaID is unable to be modified here.
GroupID (*2, 3)	Any name can be input for this item. The name input here becomes the name of the folder in which the recorded data is stored. Up to 70 characters*4. (Ex. 1) Use original VTR tape numbers. (Ex. 2) Use a number sequence for programs. Do not leave this field blank when registering LTO tapes recorded by the unit to an LTS-MAM. If this field is blank, “generic” will be used as the folder name.
ContentID	Leave this field blank or enter any string, up to 100 characters in length. This field is intended for content management use, e.g. VTR tape ID numbers or existing content ID numbers can be entered.

(Continued on next page)

Item	Description
FileID (*2, 3)	This ID corresponds to the filename. When specifying a filename, input any character string, up to 70 characters* 4 in length. Use unique names under a single Group ID number, because a File ID is used as the file name and the file is stored in a folder whose name is specified under the Group ID. The File ID will be displayed in the file list. To change the filename, enter a new name and press the [ENTER] or [PLAY] button. The file will automatically close. The File Open dialog then appears and the new file name is displayed. Select the file again.
Title	Leave this field blank or enter any string, up to 100 characters in length. This field is intended for content title use, such as program or source titles, and is displayed in the file list.
Synopsis	Leave this field blank or enter any string, up to 100 characters in length. This field is intended for content summary use, such as content descriptions or related information, and allows line breaks.
Rights	Leave this field blank or enter any string, up to 100 characters in length. This field is intended for content rights use, to include company names, copyright or proprietary information, etc..

*2 The following characters cannot be used for **GroupID** or **FileID**: / \ ? * : | ~ < > . ". Up to 70 characters are available.

*3 In addition to Note *2 above, the following characters cannot be used when linking with MediaConcierge: = % ' ; ! # \$ & , @ ^

*4 The total number of combined GroupID and FileID characters must be 100 or less.

Once video has been recorded, the following folder structure is created on the LTO tape. Data files with a File ID name are stored under the "data" folder, which is located in a "File ID" folder.

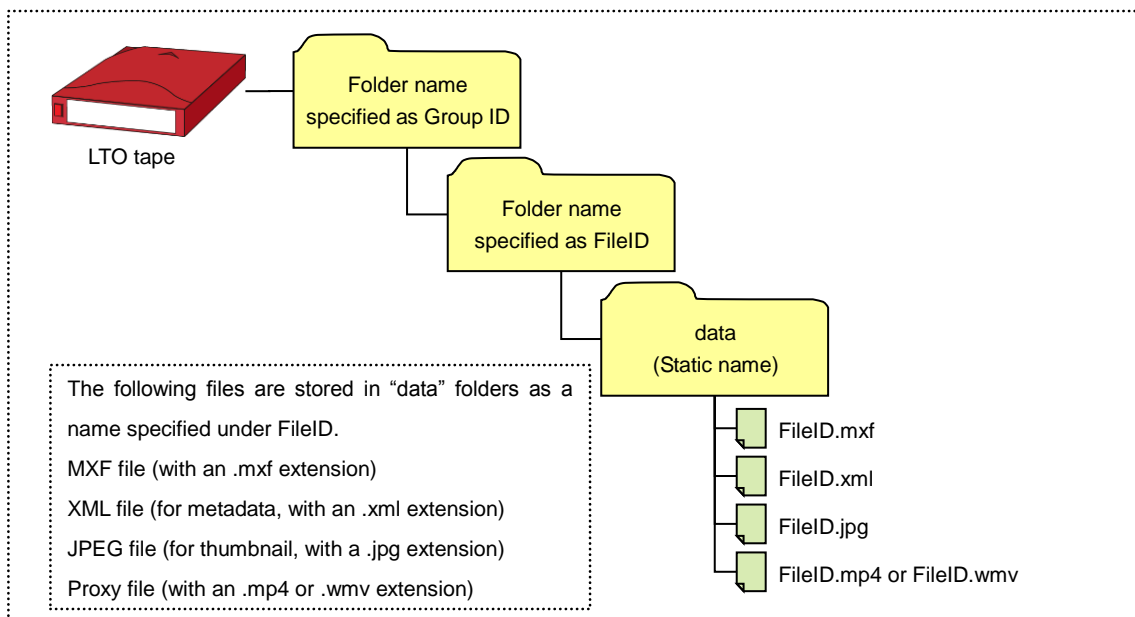

4-7. Setting Screens

When **Settings** is selected in the **Main Menu** screen, the **Recording Settings #1** screen appears.

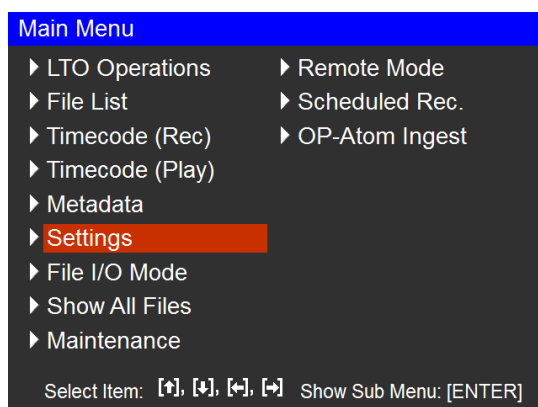

4-7-1. Recording Settings #1 Screen

Recording settings are selected on this screen. Use the [↑] and [↓] buttons to select an item, and the [ENTER] or [PLAY] button to enter the setting screen or confirm changes. When the [MENU] or [←] button is pressed, operation returns to the **Main Menu** screen. Use the [→] button to move to the **Recording Settings #2** screen. Change settings using the jog dial.

* ↻ signifies that changes can be made to the setting using the jog dial.

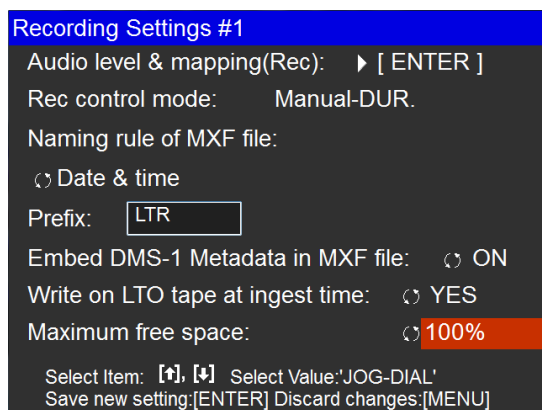

Item	Description	
Audio level & mapping(Rec)	When the [ENTER] or [PLAY] button is pressed, operation transfers to the Audio Input Level and Channel Mapping screen.	
Rec control mode	Displays the recording mode settings.	
Naming rule of MXF file	Date & time	Generated automatically based on actual date and time.
	Sequential number	Generated automatically as a running number.
Prefix (*1)	Specifies the head character string of the MXF file. Up to 55 characters can be used.	
Embed DMS-1 Metadata in MXF file	Selects whether DMS-1 metadata is embedded into MXF files. Regardless of this setting, LTR-200HS7 embeds metadata into MXF files.	
	ON	Embeds metadata into MXF files.
	OFF	Does not embed metadata into MXF files.

*1 USB keyboard required for settings to be entered.

(Continued on next page)

Item	Description	
Write on LTO tape at ingest time	Selects the type of writing.	
	YES	Writes content to a cache file on the internal hard disk and to an LTO tape during recording. The cached file is automatically deleted when the LTO tape is unmounted after finishing the recording. The usage rate shown in the Monitoring screen (5-1-3 (3)) includes the used space in the LTO tape and the total size of listed files, highlighted in blue, in the file list.
	NO	Writes content to a cache file on the internal hard disk but not to an LTO tape during recording. Content is able to be written to an LTO tape from the cached file later. (Refer to "Copy to tape" in "4-3-1. File Operation screen".) Recording will automatically stop if the total size of all files written to the internal hard disk drive exceeds the free space in the LTO tape. The usage rate shown in the Monitoring screen (5-1-3 (3)) includes the used space in the LTO tape and the total size of listed files as blue back-ground in the file list, highlighted in blue, in the file list.
	YES+1copy	Writes content to a cache file on the internal hard disk and to an LTO tape during recording. The cached file is not automatically deleted when the LTO tape is unmounted after finishing recording. The cache file data can be copied to other LTO tapes. Recording will automatically stop if the total size of all files written to the internal hard disk drive exceeds the free space in the LTO tape. The usage rate shown in the Monitoring screen (5-1-3 (3)) indicates the amount of used space in the LTO tape.
Max writable space (*1)	80%, 85% 90%, 95%, 99%, 100%	Sets the free space limit (percentage) on LTO tapes. If the amount of used space on a tape exceeds the limit during a recording, the recording automatically stops.

*1 Writing retries may occur depending on LTO tape or head conditions and reduce the amount of available free space on tapes. Tape data, therefore, may in some cases be unable to be copied due to space restrictions caused by retries. To use auto-copy functions, set the maximum amount of tape cartridge usage to less than 90%.

◆ **Audio Input Level and Channel Mapping Screen**

The recording audio level is changed on this screen.

Use the [←] and [→] buttons to select the target channel, and use [↑] and [↓] buttons or jog dial to change the values. The changes are reflected immediately.

When the [MENU] button is pressed, operation returns to the **Recording Settings #1** screen.

In recording mode, this screen can be displayed by setting the switch marked Audio on the front panel to Level (bottom).

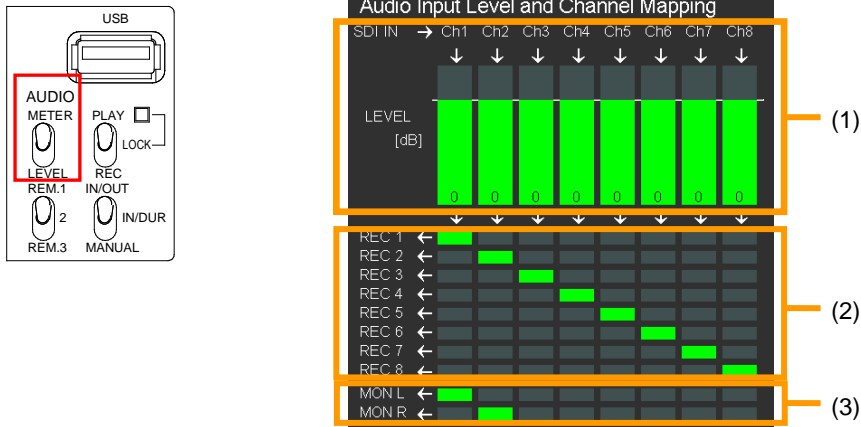

No.	Description
(1)	The audio level can be separately adjusted in 0.1 dB increments for channels 1 to 8. Adjust the level setting in 1 dB increments using the jog dial and in 0.1 dB increments using the [↑] and [↓] buttons. The maximum setting is +20 dB, and the minimum setting is -60 dB.
(2)	Channel mapping can be changed separately for channels 1 to 8 using the jog dial.
(3)	Sound from the left or right channel to be monitored as the sound heard through the headphones or internal speakers can be selected using the jog dial.

4-7-2. Recording Settings #2 Screen

Additional recording settings are selected on this screen. Use the [↑] and [↓] buttons to select an item, and use the [ENTER] or [PLAY] button to enter the setting changes. When the [MENU] button is pressed, operation returns to the **Main Menu** screen. Use the [←] button to return to the **Recording Settings #1** screen and the [→] button to move to the **System Settings** screen. Change settings using the jog dial.

* ↻ signifies that changes can be made to the setting using the jog dial.

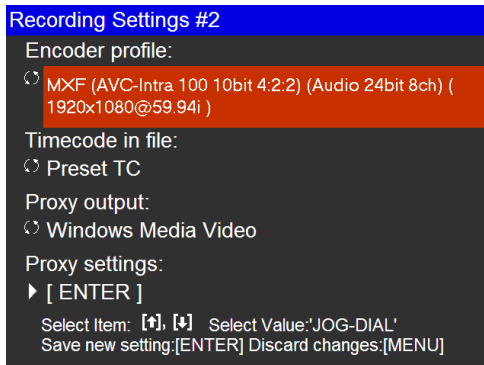

Item	Description
Encoder profile	<p>Selects and specifies the compression method and bit rate to be used for recording from the following options.</p> <p>MXF (MPEG-2 HD Video 18 Mbps CBR MP@H14) (Audio 16bit 4ch) (1440x1080@50i) MXF (MPEG-2 HD Video 25 Mbps CBR MP@H14) (Audio 16bit 4ch) (1440x1080@50i) MXF (MPEG-2 HD Video 35 Mbps CBR MP@H14) (Audio 16bit 4ch) (1440x1080@50i) MXF (MPEG-2 HD Video 50 Mbps CBR 422P@HL) (Audio 24bit 8ch) (1920x1080@50i) MXF (MPEG-2 HD Video 25 Mbps CBR MP@H14) (Audio 16bit 4ch) (1280x720@50p) MXF (MPEG-2 HD Video 35 Mbps CBR MP@H14) (Audio 16bit 4ch) (1280x720@50p) MXF (MPEG-2 HD Video 50 Mbps CBR 422P@HL) (Audio 24bit 8ch) (1280x720@50p) MXF (MPEG-2 HD Video 18 Mbps CBR MP@H14) (Audio 16bit 4ch) (1440x1080@59.94i) MXF (MPEG-2 HD Video 25 Mbps CBR MP@H14) (Audio 16bit 4ch) (1440x1080@59.94i) MXF (MPEG-2 HD Video 35 Mbps CBR MP@H14) (Audio 16bit 4ch) (1440x1080@59.94i) MXF (MPEG-2 HD Video 50 Mbps CBR 422P@HL) (Audio 24bit 8ch) (1920x1080@59.94i) MXF (MPEG-2 HD Video 25 Mbps CBR MP@H14) (Audio 16bit 4ch) (1280x720@59.94p) MXF (MPEG-2 HD Video 35 Mbps CBR MP@H14) (Audio 16bit 4ch) (1280x720@59.94p) MXF (MPEG-2 HD Video 50 Mbps CBR 422P@HL) (Audio 24bit 8ch) (1280x720@59.94p) MXF (DNxHD 120 Mbps 8bit 4:2:2) (Audio 24bit 8ch) (1920x1080@50i) MXF (DNxHD 185 Mbps 8bit 4:2:2) (Audio 24bit 8ch) (1920x1080@50i) MXF (DNxHD 185 Mbps 10bit 4:2:2) (Audio 24bit 8ch) (1920x1080@50i) MXF (DNxHD 115 Mbps 8bit 4:2:2) (Audio 24bit 8ch) (1280x720@50p) MXF (DNxHD 175 Mbps 8bit 4:2:2) (Audio 24bit 8ch) (1280x720@50p) MXF (DNxHD 175 Mbps 10bit 4:2:2) (Audio 24bit 8ch) (1280x720@50p) MXF (DNxHD 145 Mbps 8bit 4:2:2) (Audio 24bit 8ch) (1920x1080@59.94i) MXF (DNxHD 220 Mbps 8bit 4:2:2) (Audio 24bit 8ch) (1920x1080@59.94i) MXF (DNxHD 220 Mbps 10bit 4:2:2) (Audio 24bit 8ch) (1920x1080@59.94i) MXF (DNxHD 145 Mbps 8bit 4:2:2) (Audio 24bit 8ch) (1280x720@59.94p) MXF (DNxHD 220 Mbps 8bit 4:2:2) (Audio 24bit 8ch) (1280x720@59.94p) MXF (DNxHD 220 Mbps 10bit 4:2:2) (Audio 24bit 8ch) (1280x720@59.94p) MXF (AVC-Intra 100 10bit 4:2:2) (Audio 24bit 8ch) (1920x1080@50i) MXF (AVC-Intra 100 10bit 4:2:2) (Audio 24bit 8ch) (1920x1080@59.94i) MXF (AVC-Intra 100 10bit 4:2:2) (Audio 24bit 8ch) (1280x720@50p) MXF (AVC-Intra 100 10bit 4:2:2) (Audio 24bit 8ch) (1280x720@59.94p) MXF (AVC-Intra 50 10bit 4:2:0) (Audio 24bit 8ch) (1440x1080@50i) MXF (AVC-Intra 50 10bit 4:2:0) (Audio 24bit 8ch) (1440x1080@59.94i) MXF (AVC-Intra 50 10bit 4:2:0) (Audio 24bit 8ch) (960x720@50p) MXF (AVC-Intra 50 10bit 4:2:0) (Audio 24bit 8ch) (960x720@59.94p) MXF (DVCPRO HD 8bit 4:2:2) (Audio 24bit 8ch) (1440x1080@50i) MXF (DVCPRO HD 8bit 4:2:2) (Audio 24bit 8ch) (1280x1080@59.94i) MXF (DVCPRO HD 8bit 4:2:2) (Audio 24bit 8ch) (960x720@50p) MXF (DVCPRO HD 8bit 4:2:2) (Audio 24bit 8ch) (960x720@59.94p)</p>

(Continued on next page)

Item	Description	
Timecode in file	Selects time code to be embedded in output files.	
	Ancillary TC or LTC	Time code embedded in SDI (ancillary data) or LTC signal input.
	Preset TC	Fixed start time code.
Proxy output	Selects type of proxy video to be output.	
	No output	No proxy video output
	Windows Media Video	Creates Windows Media Video as the proxy video.
	MP4 H.264 Video	Creates MP4 H.264 Video as the proxy video.
Proxy settings (*1)	Displays the setting screen for the proxy video to be output. For details, refer to "Proxy Settings" described below.	

*1 **Proxy settings** ([ENTER]) will be grayed out and cannot be set when **Proxy output** is set to **No Output**.

◆ Proxy Settings

Use the [↑] and [↓] buttons to select an item, and the [ENTER] or [PLAY] button to enter (select) settings or the [MENU] button to cancel selections. Change settings using the jog dial.

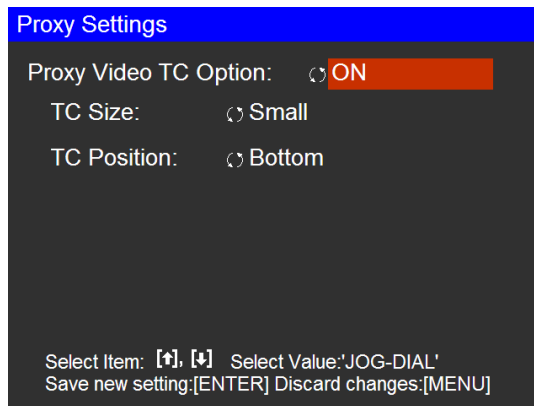

Item	Description	
Proxy Video TC Option	Specifies whether to imprint the time code on the proxy video.	
	ON	Imprints the time code.
	OFF	No time code is imprinted.
TC Size (See "TC Size" below.)	Specifies the character size of the time code to be imprinted.	
	Large	Large characters
	Medium	Standard size characters
	Small	Small characters
TC Position (See "TC Position" below.)	Specifies the character position of the time code to be imprinted.	
	Top	Screen top
	Center	Screen center
	Bottom	Screen bottom

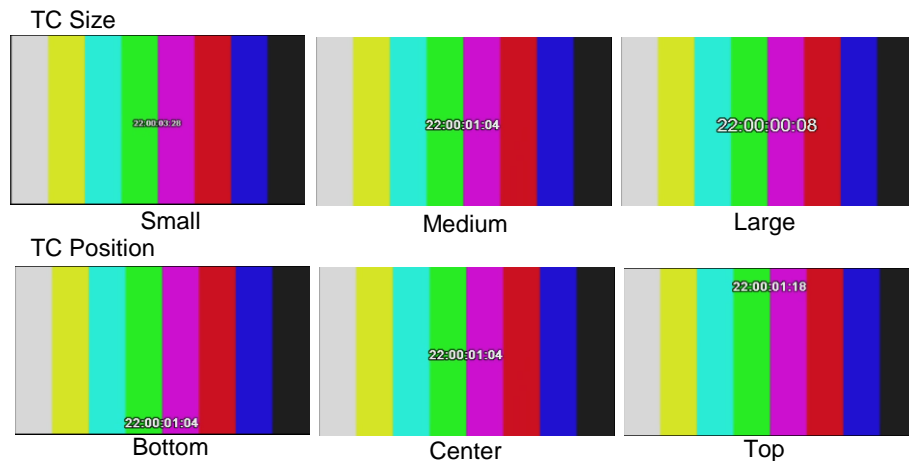

4-7-3. System Settings Screen

Playback and SDI output settings are selected on this screen. Use the [↑] and [↓] buttons to select an item, and the [ENTER] or [PLAY] button to enter settings. When the [MENU] button is pressed, operation returns to the **Main Menu** screen. Use the [←] button to move to the **Recording Settings #2** screen and the [→] button to move to the **Input Signal Settings** screen. Change settings using the jog dial.

* ↻ signifies that changes can be made to the setting using the jog dial.

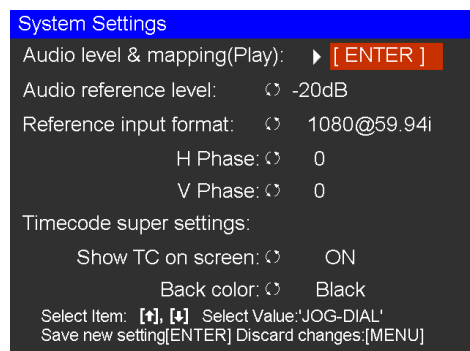

Item	Description
Audio level & mapping(Play)	When the [ENTER] or [PLAY] button is pressed, operation transfers to the Audio Output Level and Channel Mapping screen.
Audio reference level	Specifies the center level of the audio meter when Fine is selected. -20 dB, -18 dB or -16 dB can be selected.
Reference input format	Selects the type of genlock for the output signals: Free run ^(※1) 525@60 625@50 1080@59.94i 1080@50i 720@59.94p 720@50p At the 1080@ and 720@ settings, tri-level sync signals should be input; at the 525@ and 625@ settings, black burst signals should be input.

Item		Description	
H Phase (*2)		Sets the horizontal phase of the genlock. Unit: clock For the adjustment range, refer to the "Genlock adjustments" table on the next page.	
V Phase (*2)		Use this to set the vertical phase of the genlock. Unit: line For the adjustment range, refer to the "Genlock adjustments" table on the next page.	
Timecode super settings	Show TC on screen	Specifies whether to superimpose the time code and output it to SDI OUT3 and 4 on the rear panel.	
		ON	Superimposes and outputs the time code.
		OFF	Time code is not superimposed or output.
	Back color	Specifies the background color for the time code which is superimposed and output to SDI OUT3 and 4 on the rear panel.	
		Black	Black background
White		White background	

*1 "Free run" is always selected for operation with SDI input signals.

*2 When "Free run" has been selected as the Reference input format setting, no changes can be made to the settings of these items. When high values are set for H Phase or V Phase, the device which receives the output signals of the LTR recorder will not be able to track the signals so images may not be displayed or they may have odd colors.
For the adjustment ranges, steps and initial values, refer to the "Genlock adjustments" table on the next page.

◆ **Audio Output Level and Channel Mapping Screen**

Use the [←] and [→] buttons to select the target channel, and the [↑] and [↓] buttons or jog dial to change values. Changes are reflected immediately. When the [MENU] button is pressed, operation returns to the **System Settings** screen.

In playback mode, this screen can be displayed by setting the switch marked Audio on the front panel to Level (bottom).

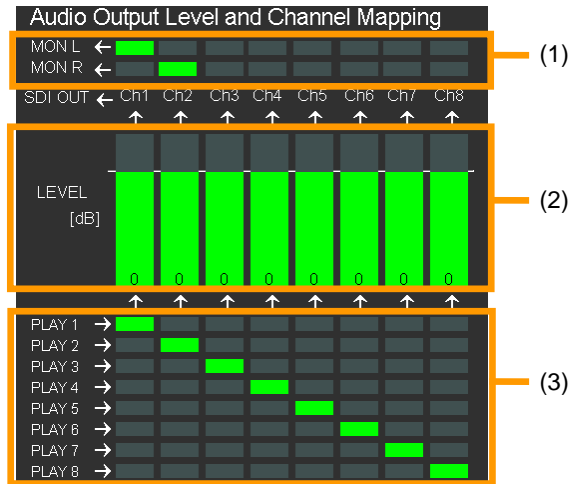
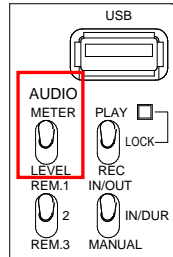

No.	Description
(1)	Sound from the left or right channel to be monitored as the sound heard through the headphones or internal speakers can be selected using the jog dial.
(2)	The audio level can be separately adjusted in 0.1 dB increments for channels 1 to 8. Adjust the level setting in 1 dB increments using the jog dial and in 0.1 dB increments using the [↑] and [↓] buttons. The maximum setting is +20 dB, and the minimum setting is -60 dB.
(3)	Channel mapping can be changed separately for channels 1 to 8 using the [↑] and [↓] buttons or the jog dial.

◆ Genlock Adjustments

H Phase

TV system	Adjustment range	Step	Initial value
1080@59.94i	-1100 to +1099 (-14.83 μs to +14.81 μs)	1 (13.48 ns)	0
1080@50i	-1320 to +1319 (-17.79 μs to +17.78 μs)	1 (13.47 ns)	0
720@59.94p	-825 to +824 (-11.12μs to +11.11 μs)	1 (13.48 ns)	0
720@50p	-990 to +989 (-13.34 μs to +13.32 μs)	1 (13.47 ns)	0
525@60	-858 to +857 (-31.78μs to +31.74 μs)	1 (37.04 ns)	0
625@50	-864~+863 (-32.00μs to +31.96 μs)	1 (37.04 ns)	0

V Phase

TV system	Adjustment range	Step	Initial value
1080@59.94i	-562 lines to +562 lines (-16.68 ms to +16.68 ms)	1 line (29.66 μs)	0
1080@50i	-562 lines to +562 lines (-20.00 ms to +20.00 ms)	1 line (35.56 μs)	0
720@59.94p	-375 lines to +374 lines (-8.34 ms to +8.32 ms)	1 line (22.24 μs)	0
720@50p	-375 lines to +374 lines (-10.00 ms to +9.97 ms)	1 line (26.67 μs)	0
525@60	-262 lines to +262 lines (-16.68 ms to +16.68 ms)	1 line (63.56 μs)	0
625@50	-312 lines to +312 lines (-20.00ms to +20.00 ms)	1 line (64.00 μs)	0

4-7-4. Input Signal Settings Screen

The input signals are checked and selected on this screen. Use the [↑] and [↓] buttons to select an item, and the [ENTER] or [PLAY] button to enter settings. When the [MENU] button is pressed, operation returns to the **Main Menu** screen. Use the [←] button to move to the **System Settings** screen and the [→] button to the **Save/Recall Setting** screen. Change settings using the jog dial.

* ↻ signifies that changes can be made to the setting using the jog dial.

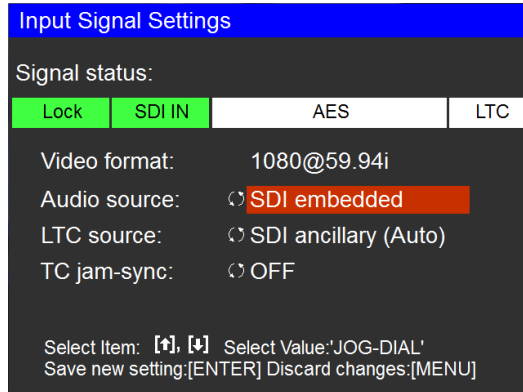

Item	Description
Signal status	Indicates the status of input signals lights green if input signals are present, lights white if they are absent.
	Lock Indicates synchronization with SDI input signals.
	Unlock Indicates no synchronization with SDI input signals. (Unlock may be set as a result of a mistake made in the HD/SD setting.)
	SDI IN Indicates whether SDI input signals are present.
	AES AES IN(1/2), AES IN(3/4) or AES IN (1/2/3/4) is displayed depending on the AES input signals.
	LTC Indicates whether LTC input signals are present.
Video format	Indicates the video format of input signals. 525@60 625@50 1080@59.94i 1080@50i 720@59.94p 720@50p Unknown (not displayed with normal operation)
Audio source	Selects the audio input signals to be used for recording. SDI embedded AES IN Mute (no sound)
LTC source	Selects the LTC input signals to be used for recording.
	SDI ancillary(Auto) Uses an SDI timecode.
	SDI ancillary(LTC) Uses the LTC in the SDI signal.
	SDI ancillary(VITC) Uses the VITC in the SDI signal.
	LTC IN Uses the LTC IN timecode.
	LTC IN(1F delay) LTC IN(2F delay) LTC IN(3F delay) Uses the LTC IN timecode by adding 1-, 2- or 3-frame delay.
Discard Discards the SDI timecode.	
TC jam-sync	When an input timecode is discontinuous in recording or playing back, selects whether or not to synchronize.
	OFF Does not synchronize the timecode.
	ON Synchronizes the discontinuous timecode.

4-7-5. Save/Recall Settings Screen

Menu settings* can be saved and then recalled on this screen. This screen also allows users to return menu settings to their default values.

When the [MENU] button is pressed, operation returns to the **Main Menu** screen. Use the [←] button to move to the **Input Signal Settings** screen.

* The following screen settings can be saved and recalled on this screen:

- Timecode(Rec)
- Audio Input Level and Channel Mapping
- Audio Output Level and Channel Mapping
- Metadata
- Recording Settings #1
- Recording Settings #2
- Proxy Settings
- System Settings
- Input Signal Settings
- GPI Settings
- Proxy Output Settings
- VTR Control Settings
- Cache mode settings

Settings in the Timecode (Play), Change IP Address, Change date & time, FTP Settings and Scheduled Recording screens cannot be saved.

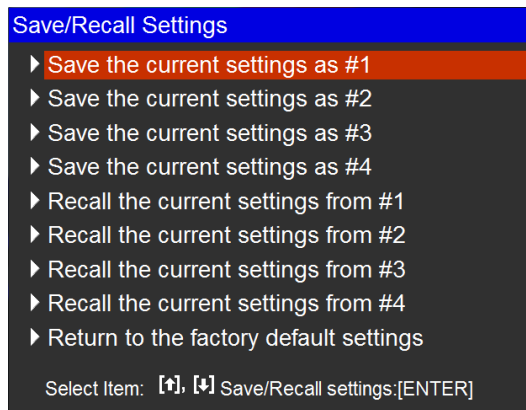

Four different sets of settings can be saved as #1, #2, #3 and #4.

To Save Settings:

- (1) Use [↑] and [↓] to align the cursor with the target to select from #1, #2, #3 or #4.
- (2) Press [ENTER] or [PLAY].
- (3) A confirmation dialog box will appear.
- (4) Press [ENTER].

To Recall Settings:

- (1) Use [↑] and [↓] align the cursor with the target to select from #1, #2, #3 or #4.
- (2) Press [ENTER] or [PLAY].
- (3) A confirmation dialog box will appear.
- (4) Press [ENTER]. The settings will be applied and the system will automatically reboot.

To Return to Default:

- (1) Use [↑] and [↓] to align the cursor with "Return to the factory default settings".
- (2) Press [ENTER] or [PLAY].
- (3) A confirmation dialog box will appear.
- (4) Press [ENTER]. The default settings will be applied and the system will automatically reboot.

4-8. File I/O Mode Screen

File input/output operation using FTP are performed on this screen.

When “**File I/O Mode**” is selected in the **Main Menu** screen, a **File I/O mode** screen such as the one shown below is displayed. When this screen is displayed, the LTR recorder operates as an FTP server, enabling files on the LTO tape to be directly read from or written to the PC. Press the **[ENTER]**, **[PLAY]**, **[←]** or **[MENU]** button to restore the **Monitoring** screen.

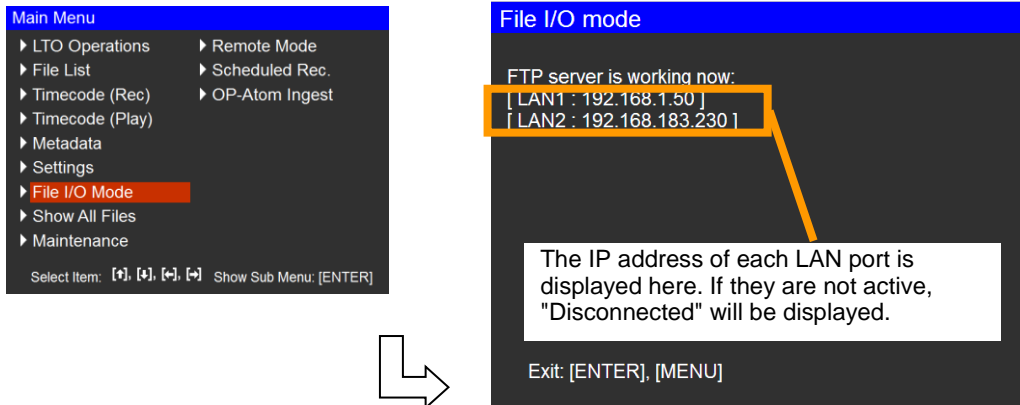

- Operation cannot be changed to File I/O mode while recording is in progress.
- An open playback file that is present closes, and operation is then changed to File I/O mode.
- If an LTO tape is not mounted, operation cannot be changed to File I/O mode.

4-8-1. FTP Clients

Go to the **File I/O mode** screen, then connect to the LTR recorder using the FTP client (*1).

- *1 Transfer speed will differ depending on the FTP client. Bear in mind that some software will not support transfer file sizes exceeding 4GB. The setup method and setting names may vary according to the FTP client. The recommended FTP client is "**FileZilla Client**."

- Select unlimited as the timeout setting.
- Select "1" if a setting for the number of simultaneous transfers has been established.
- Check on the **Force UTF-8** box, if you want to name files or directories using any characters in multi-byte characters such as Japanese, Chinese, etc...

• Setting Method

The setting method using **FileZilla Client** is described below.

- (1) On the menu bar, select [**Edit**] > [**Settings**].
- (2) After selecting [**Settings**], the settings dialog box is displayed. Select [**Connection**], and set the timeout setting to "0."

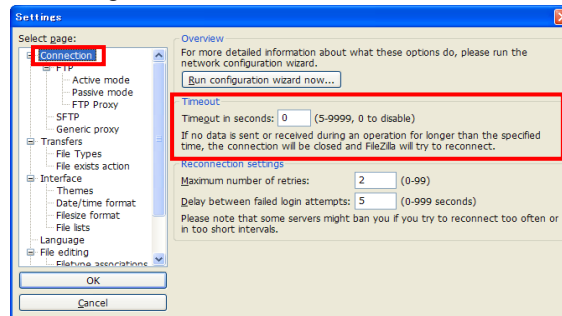

- (3) Select [**Transfers**] on the settings dialog box, and set the **Maximum number of simultaneous transfers** to 1.

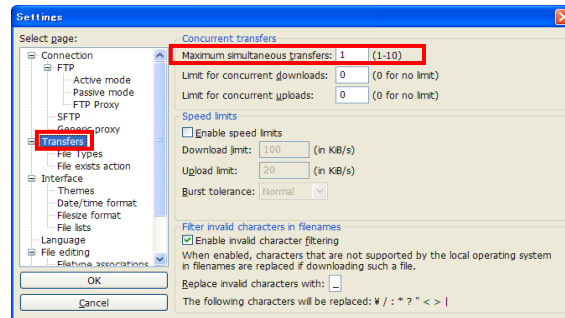

- (4) Select "File > **Site Manager**."
- (5) Check on the **Force UTF-8** box on the **Charset** tab.

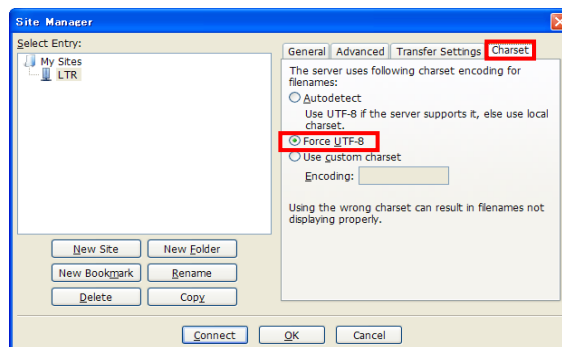

- **Connection and Downloading Methods**

The connection and downloading methods using **FileZilla Client** are described below.

- (1) On the menu bar, select "**File > Site Manager**".
- (2) The site manager dialog box is displayed. Input "Host(*1)," "User(*2)" and "Password(*2)" on the General tab, then press the connect button.

*1 For the host, input the IP address displayed in the **File I/O mode** screen. For details, refer to "4-1-7. File I/O mode screen."

*2 For user name and password, the login name differs depending on the destination. For details, refer to the table below.

User name	Password	Destination	Function
fileio	ltrltr21	LTO tape	Reads/writes files on the LTO cartridge.
metadata (*3)	ltrltr21	Metadata	Set from external metadata source XML.

*3 The user account "**metadata**" allows the user to connect the LTR recorder without displaying the **File I/O mode** screen.

- (3) After completing the connections, a screen such as the one shown below appears. Select the location to where the files to be downloaded in a local site as shown in block **A**.

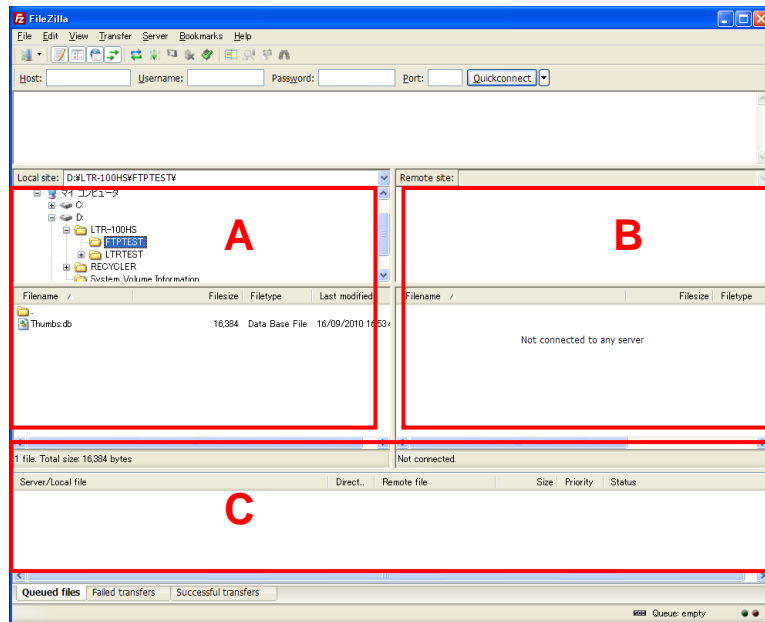

- (4) Select the files to be downloaded from remote site **B** (LTR recorder side), and after right-clicking, select "Download." Download status and results are shown in **C**.

4-9. Show All Files Screen

LTO tape files are displayed on this screen. When “**Show All Files**” is selected in the **Main Menu** screen, a screen such as the one shown on the right appears.

Use the [↑] and [↓] buttons or the jog dial to scroll up and down, and press the [MENU] button to return to the **Main Menu** screen. On the show all files screen, the files are listed in the sequence of their filenames, dates and times (year/month/day/hours/minutes) of previous updates, and file sizes (in byte units), and all directories (folders) and files on the LTO tape are displayed.

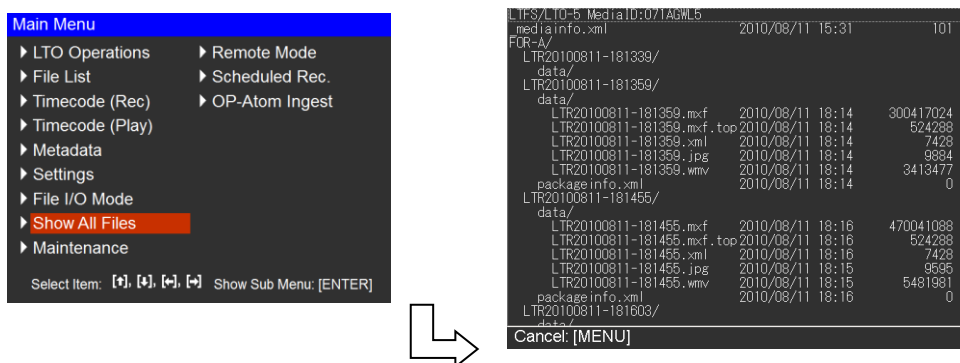

4-10. Maintenance Menu Screen

The LTR recorder input and output settings can be changed, and functions relating to maintenance displayed on this screen. When “**Maintenance**” is selected in the **Main Menu** screen, a screen such as the one shown below on the right appears.

Use the [↑] and [↓] buttons or the jog dial to select an item, and use the [ENTER] or [PLAY] button to enter settings. When the [MENU] button is pressed, operation returns to the **Main Menu** screen.

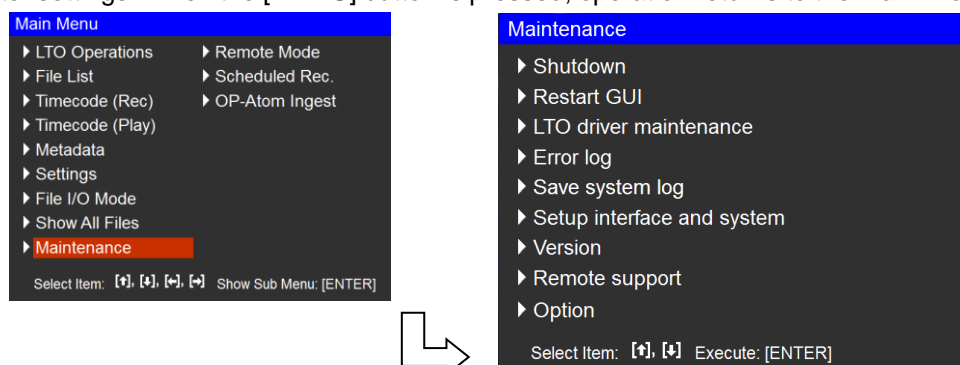

Item	Description
Shutdown	Shuts down the LTR recorder and turns off its power. The operation is the same as when the [Power] button is pressed.
Restart GUI	Restarts the GUI function.
LTO driver maintenance	Displays the maintenance menu of the LTO drive. For details, refer to “4-10-1. LTO Driver Maintenance Menu Screen.”
Error log	Transfers to the screen on which errors occurring during recording (mainly errors relating to the input signals) are displayed.
Save system log	Copies the system log into a USB memory. Refer to “4-10-2. Saving the System Log” for details.
Setup interface and system	Displays the screen on which to change the input/output settings. Refer to “4-10-3. Interface and System Setting Menu Screen” for details.
Version	Displays a version list of the internal modules. Refer to “4-10-4. Version Information Screen” for details.

(Continued on next page)

Item	Description
Remote support	Displays the Remote support screen. Refer to "4-10-5. Remote Support Screen" for details.
Option	Displays the Option screen. Refer to each separate option manual for details on optional functions.

4-10-1. LTO Driver Maintenance Menu Screen

LTO driver maintenance is carried out on this screen.

When "LTO driver maintenance" is selected in the **Maintenance** screen, a screen such as the one shown below on the right appears. Use the [↑] and [↓] buttons or the jog dial to select an item, and the [ENTER] or [PLAY] button to enter the settings. When the [MENU] button is pressed, operation returns to the **Maintenance** screen.

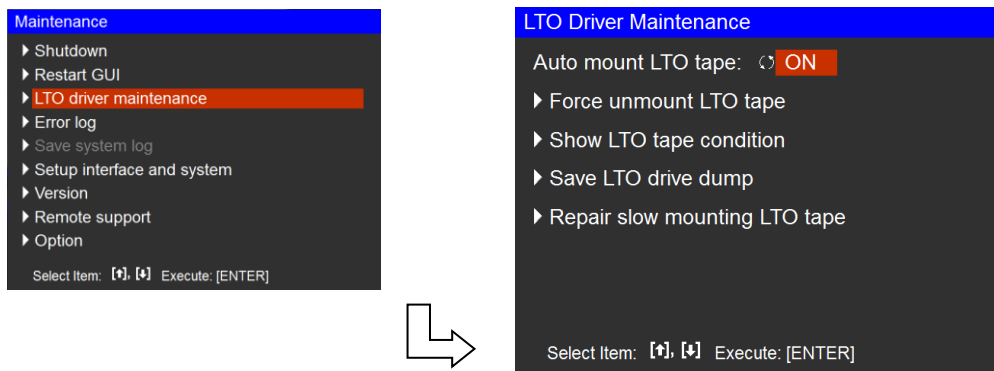

Item	Description
Auto mount LTO tape	Sets whether to automatically mount LTO tapes that are inserted.
	ON LTO tapes are automatically mounted.
	OFF LTO tapes must be mounted manually. See section 2-4-1. "Inserting and Mounting a Tape Cartridge" for details on mounting tapes manually.
Force unmount LTO tape	Forcibly unmounts an LTO tape. To be used when the regular unmount function does not operate.
Show LTO tape condition	Displays LTO tape cartridge information such as the amount of usage and recovered errors. Refer to "Show LTO tape condition" below
Save LTO drive dump	Dumps and exports LTO drive data to a USB flash drive to analyze detailed performance later. Refer to "Save LTO drive dump," described later, for details on saving dump data.
Repair slow mounting LTO tape	Repairs LTO tapes that are taking more time than usual to mount.

◆ **Show LTO tape condition**

This screen displays LTO tape cartridge information such as the load count, permanent errors, recovered errors, etc. When “Show LTO tape condition” is selected in the **LTO Driver Maintenance** screen, a screen such as the one shown below on the right appears.



Item	Description
Volume Serial	Media ID, specified during LTFS formatting. (Barcode ID of LTO tape cartridge)
Volume UUID	Volume UUID (Universally Unique Identifier) value, generated during LTFS formatting.
Label Creator	Writer (software) of the LTFS volume.
Index Creator	Information of the software that wrote the last index information
Policy Exists	Defines whether to write some files to the index partition or not. True is set for the LTR recorder.
Block Size	LTFS block size, specified during LTFS formatting. 524288 is set for the LTR recorder.
Compression	LTFS volume compression setting, specified during LTFS formatting. False is set for the LTR recorder.
Format Time (UTC)	Date and time of LTO tape LTFS formatting. (in UTC time)
Index Time (UTC)	Data and time of last modification of indexes. (in UTC time)
Media Efficiency	Overall LTO tape condition 0 : Unknown 1 : Optimal condition 255 : Worst condition
Loading Count	Total number of LTO tape cartridge-to-LTO drive mount times.
Top Passes	Total number of times the tape beginning has been passed
Middle Passes	Total number of times the tape midpoint has been passed
Index Generation	Total number of index updates
Permanent Read Errors	Total number of unrecovered data read errors over the LTO tape lifetime.
Permanent Write Errors	Total number of unrecovered data write errors over the LTO tape lifetime.
Recovered Read Errors	Total number of recovered read errors over the LTO tape lifetime.
Recovered Write Errors	Total number of recovered write errors over the LTO tape lifetime.
Total Read Size (MB)	Total number of megabytes of data read from the LTO tape over its lifetime. The total number of megabytes after compression is set rounded up to the next whole megabyte, if it is a compressed medium.
Total Written Size (MB)	Total number of megabytes of data written to the LTO tape over its lifetime. The total number of megabytes after compression is set rounded up to the next whole megabyte, if it is a compressed medium.
Alert	LTO drive tape alert flag status. Shown as 0x0000000000000000 under normal condition.

◆ Save LTO drive dump

The procedure for saving dump data from LTO drives is as described below.

If you are experiencing problems with your LTO drive and are required to collect dump data by FOR-A support staff, use the following procedure.

- (1) Connect a USB memory stick.
- (2) Select **Save LTO drive dump** in the **LTO Driver Maintenance** screen.

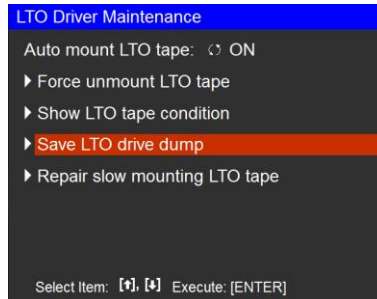

- (3) A message "**Do you save the LTO dump data?**" will appear. Press **[ENTER]** to execute the operation.

* Dump data is stored in a file named "**LTR200HSDump.zip**." Its file size varies depending on usage conditions. In some cases, the file size may exceed 10 MB.

4-10-2. Saving the System Log

The procedure for saving the system log is described below. When a malfunction has occurred and a FOR-A support staff member requests a system log file, follow the steps below to acquire the system log file.

The system log file size may exceed 500 MB when saving logs. Be sure to use a USB memory stick with enough available space.

- (1) Connect a USB memory.
- (2) Select "**Save system log**" in the **Maintenance** screen.

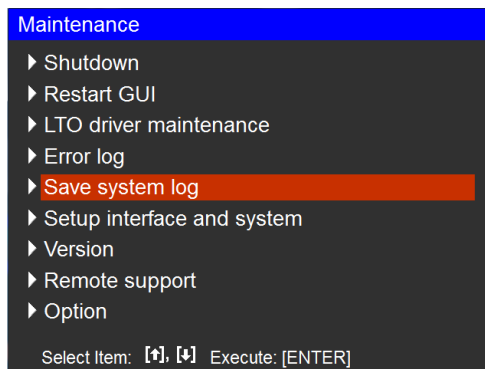

- (3) The "**Do you save the system log?**" message now appears. Press the **[ENTER]** button to save the logs.

* The system log is saved under the filename **LTR200HSlog.zip**. The system log file size will differ depending on the operating conditions. In some conditions, it may exceed 10MB.

4-10-3. Interface and System Setting Menu Screen

The archive system input and output settings are set using this menu. When “**Setup interface and system**” is selected in the **Maintenance** screen, a screen such as the one shown on the right appears.

Use the [↑] and [↓] buttons or the jog dial to select the items, and use the [ENTER] or [PLAY] button to enter settings. When the [MENU] button is pressed, operation returns to the **Maintenance** screen.

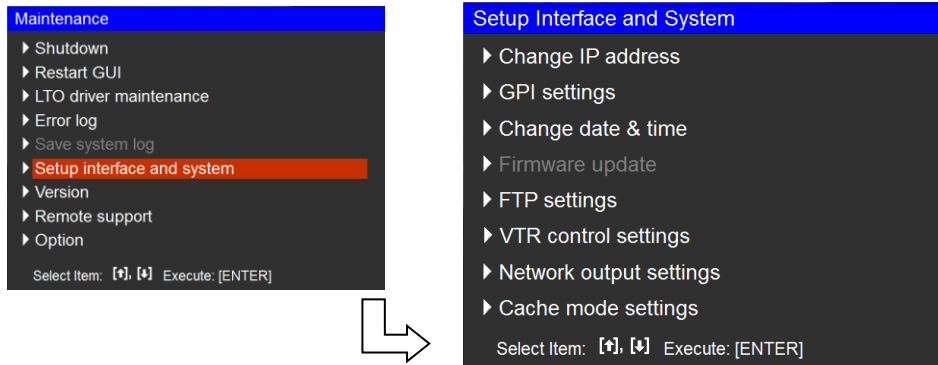

Item	Description
Change IP address	Sets the IP address. For details, refer to “Change IP Address” below.
GPI settings	Establishes GPI settings. For details, refer to “GPI Settings” in the following pages.
Change date & time	Sets the LTR recorder date and time. For details, refer to “Change Date & Time” in the following pages.
Firmware update	Updates the internal firmware. This item is not normally used. For details on the update method, refer to the documentation provided with the module to be updated.
FTP Settings	Changes the password for FTP access. For details, refer to “FTP Settings” in the following pages.
VTR control settings	Sets the VTR control for recording. For details, refer to “VTR Control Settings” in the following pages.
Network output settings	Specifies a network storage location for output recording files. For details, refer to “Network Output Settings” in the following pages.
Cache mode settings	Sets the cache mode settings.

◆ **Change IP Address**

Use this item to set the IP address. When “**Change IP address**” is selected in the **Setup interface and system** screen, a screen such as the one shown below on the right appears. Use the [←] and [→] buttons to select an item, and the [↑] and [↓] buttons or the jog dial to increase or decrease the values. Use the [ENTER] or [PLAY] button to confirm^(*1) the changes. When the [MENU] button is pressed, the **Setup interface and system** screen is restored.

*1 When [ENTER] or [PLAY] is pressed, a message is displayed. Press the [ENTER] button and shut down the system.

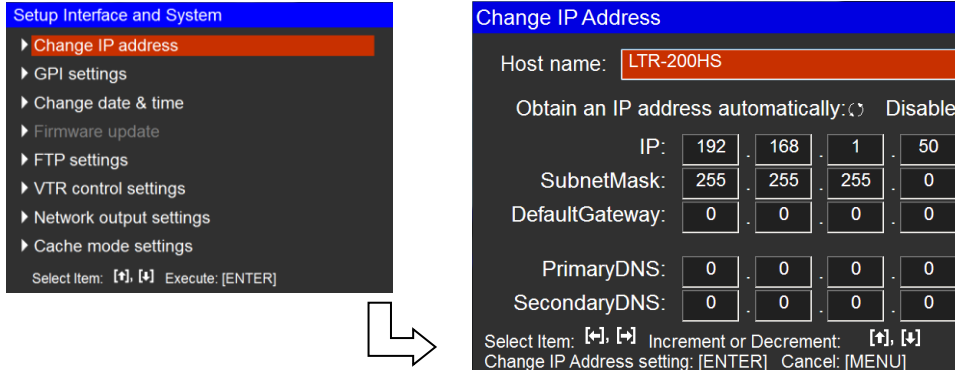

Item	Description	
Host name ^(*2)	Used to enter a host name.	
Obtain an IP address automatically	Enable	Obtains an IP address automatically.
	Disable	Sets IP address and other network settings manually in the following fields.
IP ^(*3)	Used to enter an IP address.	
SubnetMask	Used to enter a subnet mask.	
DefaultGateway	Used to enter a default gateway.	
PrimaryDNS	Used to enter a primary DNS server address.	
SecondaryDNS	Used to enter a secondary DNS server address.	

*2 Alphanumeric, space, hyphen (-) and under bar (_) characters are available.

*3 Use another address than "192.168.255.xxx." This address is applied to the LAN1 port.

Use unique host names if multiple LTR recorders are connected via a network.

◆ **GPI Settings**

Use this item to select GPI settings. When “**GPI settings**” is selected in the **Setup interface and system** screen, a screen such as the one shown on the right appears.

Use the [↑] and [↓] buttons to select an item, the jog dial to change settings, and the [ENTER] or [PLAY] button to confirm changes. When the [MENU] button is pressed, the **Setup interface and system** screen is restored.

Note that GPI inputs are disabled while displaying a menu screen such as the **Main Menu**. To receive GPI triggers, return to the **Monitoring** screen. (See "5-1-3. Monitoring Screen".)

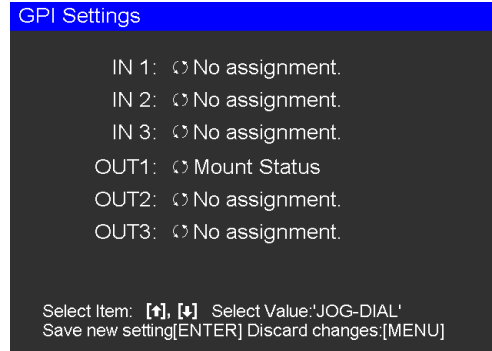
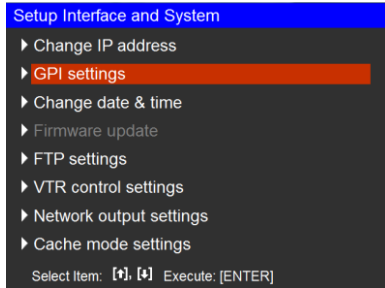

Item	Description	
IN 1	Sets the GPI IN 1 functions. Then select one of the following options.	
	Start Play	Starts playback.
	Pause Play	Temporarily stops playback.
	Start Rec	Starts recording.
	Stop Rec	Ends recording.
	Mount	Mounts an LTO tape.
	Unmount	Unmounts an LTO tape.
	Start File I/O	Starts file input/output.
	Stop File I/O	Stops file input/output.
IN 2	Sets the GPI IN 2 functions. Selection options are the same as for GPI IN 1. (For details on available options, refer to GPI IN 1.)	
IN 3	Sets the GPI IN 3 functions. Selection options are the same as for GPI IN 1. (For details on available options, refer to GPI IN 1.)	
OUT1	Sets the GPI OUT 1 function. Then select one of the following options.	
	Play Status	Make during playback.
	Pause Status	Make during playback stop when a file is open in playback mode.
	Rec Status	Make during recording.
	Stop Status	Make during recording stop when a file can be recorded in recording mode.
	Mount Status	Make during mounting.
	Unmount Status	Make during unmounting.
	File I/O Status	Make during file I/O.
	Normal Status	Make during normal status.
Tape-full	No free space	
OUT2	Sets the GPI OUT 2 functions. Selection options are the same as for GPI OUT 1. (For details on available options, refer to GPI OUT 1.)	
OUT3	Sets the GPI OUT 3 functions. The selection options are the same as for GPI OUT 1. (For details on available options, refer to GPI OUT 1.)	

◆ Change Date & Time

Use this item to set the LTR recorder's date and time. When "Change date & time" is selected in the **Setup interface and system** screen, a screen such as the one shown below on the right appears.

Use the [←] and [→] buttons to select an item, the [↑] and [↓] buttons or the jog dial to change values, and the [ENTER] or [PLAY] button to confirm changes. When the [MENU] button is pressed, operation returns to the **Setup Interface and System** screen.

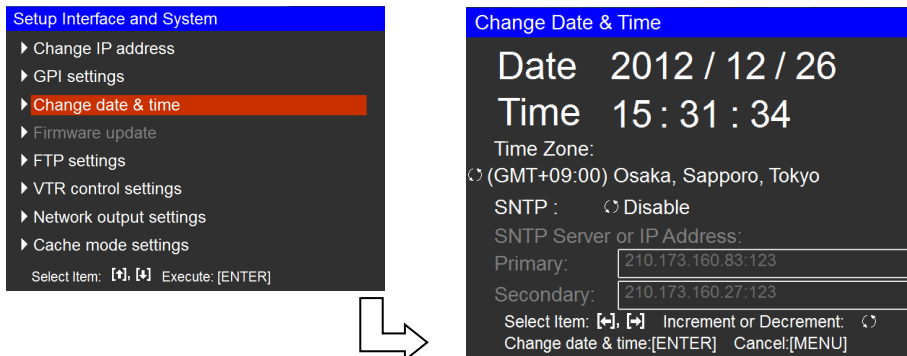

Item	Description	
Date	Sets the date manually.	
Time	Sets the time manually.	
Time Zone (*1)	Sets the time zone.	
SNTP	Enables/disables the auto time setting using SNTP (Simple Network Time Protocol).	
	Enable	Enables the auto time setting. The time setting is adjusted at startup or when an SNTP server connection is established, and is updated every 60 minutes. Enter an SNTP server name or IP address in the Primary and Secondary boxes.
	Disable	Disables the auto time setting.

*1 To change the Time Zone setting, reboot the unit.

Change timezone then shutdown system or cancel without any change.
Please push 'ENTER' key to save or 'MENU' key to cancel.
(Y...ENTER / N...MENU)

If Time Zone is changed and [ENTER] is pressed, the message as shown at left appears. Press [ENTER] to shut down the unit. To cancel the operation, press [MENU] to return to the **Setup Interface and System** screen.

◆ **FTP Settings**

Use this item to change the password used for FTP access. When “**FTP settings**” is selected in the **Setup Interface and System** screen, a screen such as the one shown below on the right appears.

Use the [↑] and [↓] buttons or the jog dial to select an item. Use the [ENTER] or [PLAY] button to execute the item selection. When the [MENU] button is pressed, the **Setup interface and system** screen is restored.

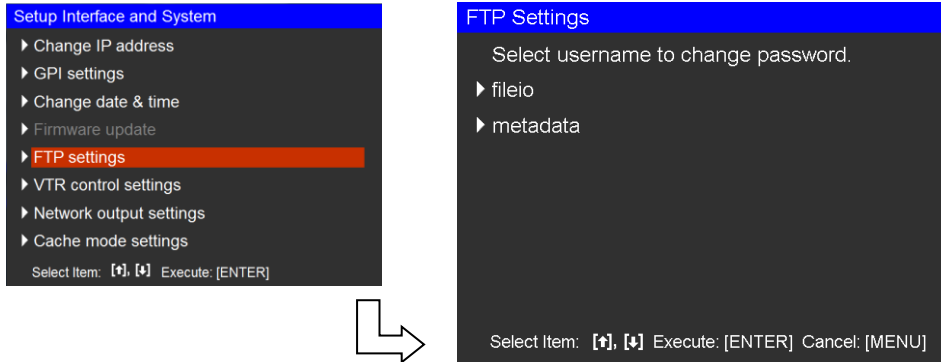

When “**fileio**” or “**metadata**” is selected, the following screen appears respectively. After inputting* the information in the fields (*1), use the [ENTER] button to apply the settings. When the [MENU] button is pressed, operation returns to the **FTP Settings** screen.

*1 A USB keyboard is required to enter the settings. The message "Caps Lock ON" or "Num Lock ON" appears to remind you that Caps Lock or Num Lock is enabled.

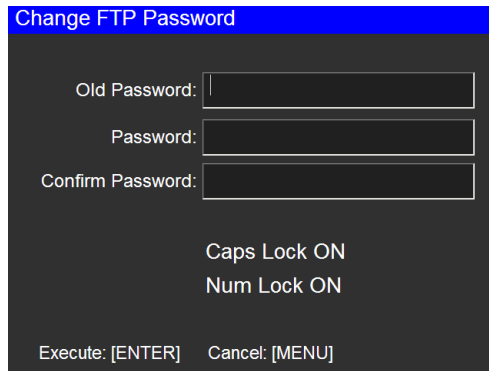

Item	Description
Old Password	Current FTP password entry field
Password	New password entry field
Confirm Password	New password re-entry field for confirmation

◆ VTR Control Settings

Set the **Pre-roll time** to more than 5 seconds. A shorter Pre-roll time may cause VTR control failure.

To set a pre-roll time on recording, ^(*1) select "**VTR control settings**" in the **Setup interface and system** screen to display the **VTR Control Settings** screen as shown below on the right. Use the [←] and [→] buttons to select an item, use the [↑] and [↓] buttons or the jog dial to change the values, and the [ENTER] or [PLAY] button to confirm changes. ^(*2) When the [MENU] button is pressed, the **Setup interface and system** screen is restored.

*1 This setting is enabled only when **REM.1** is set for REMOTE and **IN-OUT** or **IN-DUR** is selected for REC MODE. (See "5-1-2. Switches") Preroll times from **1 to 10** seconds can be set.

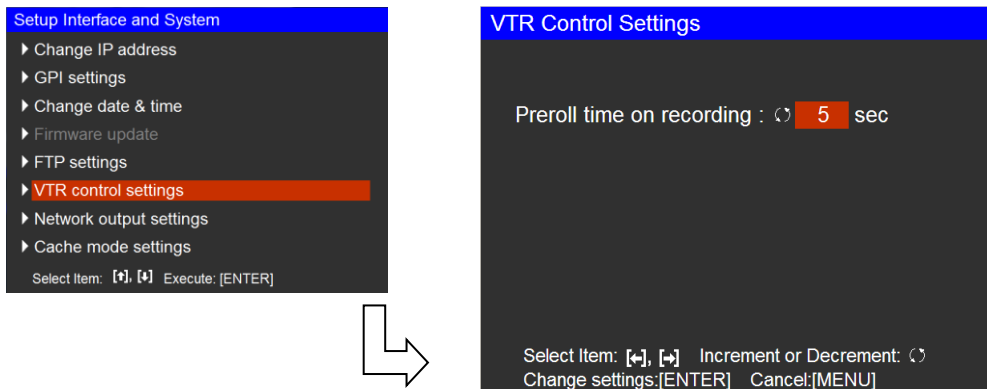

◆ Network Output Settings

Specifies a network storage location for output recording files. When "**Network output settings**" is selected in the **Setup Interface and System** screen, a screen such as the one shown below on the right appears.

Use the [↑] and [↓] buttons or the jog dial to select an item. Use the [ENTER] or [PLAY] button to enter the item selections. When the [MENU] button is pressed, the **Setup interface and system** screen is restored.

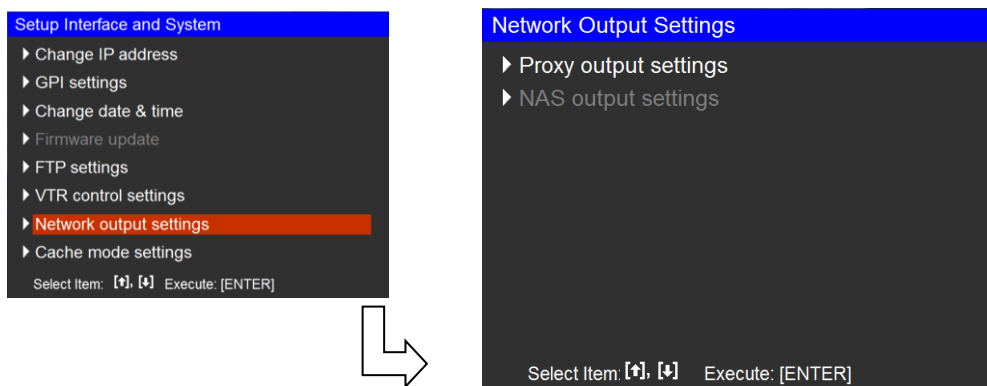

Item	Description
Proxy output settings	Specifies a storage location for proxy files when working with external databases such as MediaConcierge. For details, refer to "Proxy Output Settings" in the following pages.
NAS output settings	This menu is for optional functions. Refer to each separate option manual for details on optional functions.

◆ **Proxy Output Settings**

Specifies a storage location for proxy and XML metadata files when working with an external database such as MediaConcierge. Select "**Proxy output settings**" in the **Network Output Settings** screen to display the **Proxy Output Settings** screen as shown below on the right. Fill in required fields (*1) and press the [ENTER] button. When the [MENU] button is pressed, the **Network Output Settings** screen is restored.

*1 A USB keyboard is required to enter the settings. The message "Caps Lock ON" or "Num Lock ON" appears to remind you that Caps Lock or Num Lock is enabled.

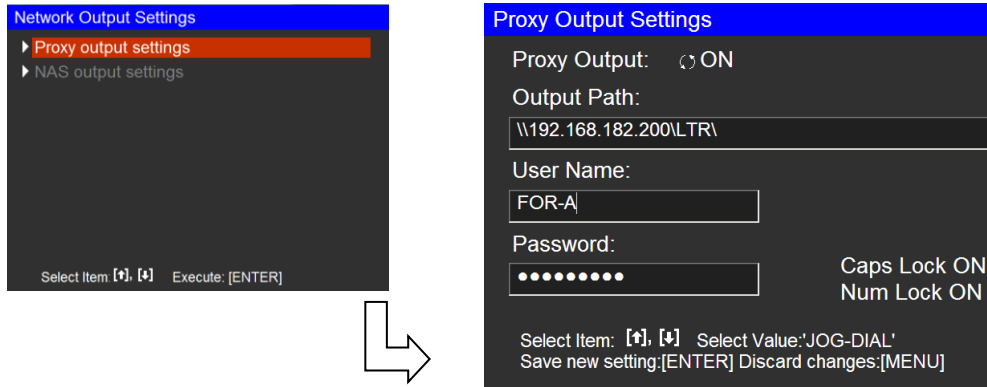

Item	Description	
Proxy Output	ON	Proxy and XML metadata files are stored.
	OFF	Proxy and XML metadata files are not stored.
Output Path	Specifies a storage location for files.	
User Name	Sets a user name and password for accessing the directory in which files are stored.	
Password		

◆ Cache Mode Settings

Specifies the file list order and file loading mode when an LTO tape is mounted. Use the [↑] and [↓] buttons to select an item, and use the [ENTER] button to confirm changes. When the [MENU] button is pressed, operation returns to the **Setup Interface and System** screen.

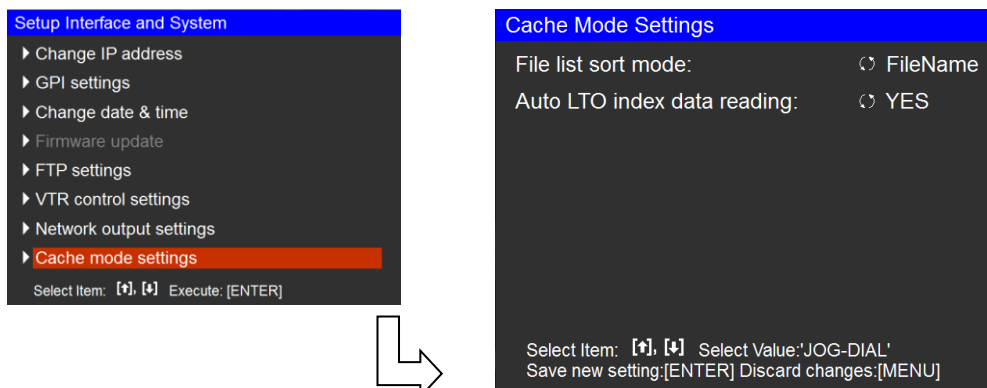

Item	Description	
File list sort mode	Specifies the file list order in the File List screen.	
	LTO Index	Lists files in the same order as they are shown in the LTO tape index.
	FileName	Lists files according to Group IDs then File IDs.
Auto LTO index data reading	Selects whether to load a tape index when mounting an LTO tape.	
	YES	A tape index is read. After mounting a tape, thumbnails and metadata are also displayed in the file list.
	NO	A tape index is not read. This setting will shorten the mount time, but, after a tape is mounted, fixed thumbnails and FileID are displayed in the file list, but other metadata information is not displayed. ^(*1)

*1 Note that the index data (other metadata information) will be automatically read when enlarging thumbnails in the file list or displaying the File Operation screen and thumbnails and metadata information are displayed in the File Operation screen.

4-10-4. Version Information Screen

This screen displays the version information for internal modules.

When “**Version**” is selected in the **Maintenance** screen, a screen such as the one shown below on the right appears. When the [MENU] button is pressed, operation returns to the **Maintenance** screen.

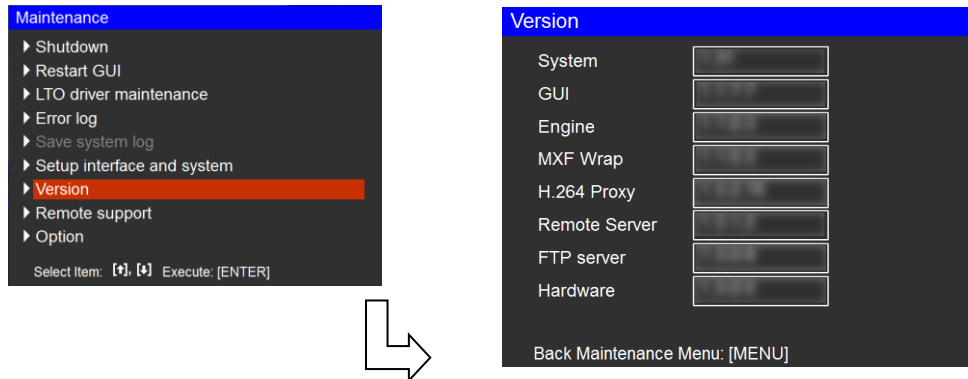

4-10-5. Remote Support Screen

This screen displays account information for Remote Support.

When “**Remote support**” is selected in the **Maintenance** screen, a screen such as the one shown below on the right appears.

Use the [↑] and [↓] buttons to select **Cancel**. When the [ENTER] button is pressed, the **Monitoring** screen is restored. When the [MENU] button is pressed, operation returns to the **Maintenance** screen.

The Remote Support plan allows your device to be remotely monitored and receive updates via the Internet from FOR-A. To subscribe to the Remote Support plan, provide your **ID** and **Password** under Account information as shown below. Although you connect the LTR-200HS7 to an internet connecting LAN, FOR-A cannot connect to your LTR-200HS7 as long as you do not enter **ID** and **Password**.

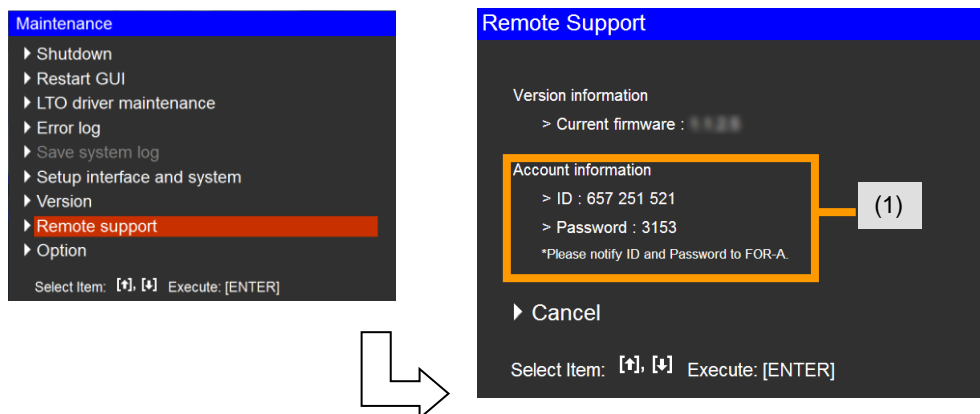

- To obtain your **ID** and **Password** for Remote Support, an Internet connection is required. Connect to the Internet via LAN. (If you need to connect to a new LAN and change LAN settings to access the Internet, refer to "Change IP Address" in "4-10-3. Interface and System Setting Menu Screen.") When the LTR-200HS7 is not connecting to the Internet, the ID field will remain blank and the message "Please connect to the internet and reopen "Remote Support" screen." is displayed under the password field.
- Do not close this screen during a remote support session.

4-11. Remote Mode Screen

Reads and writes LTO tapes by remote control.

To read or write LTO tapes from LTR Browser (LTR-BWIN-J/E and LTR-BMAC-J/E) or MediaConcierge Center (MCS-100MC) through the LTR link option, open the Remote Mode screen.

When “**Remote Mode**” is selected in the **Main Menu** screen, a **Remote Mode** screen such as the one shown below on the right is displayed. When this screen is displayed, the LTR recorder operates as an FTP server, enabling the files on the LTO tape to be directly read from or written to the PC. Press the [ENTER], [PLAY], [←] or [MENU] button to return to the **Monitoring** screen.

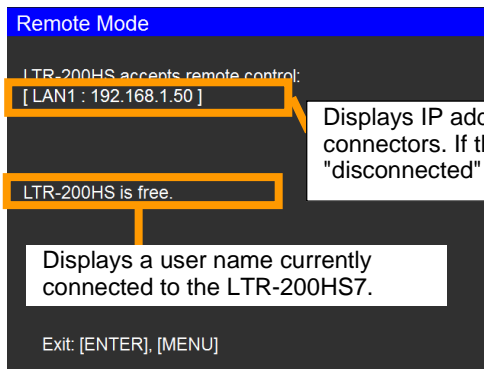
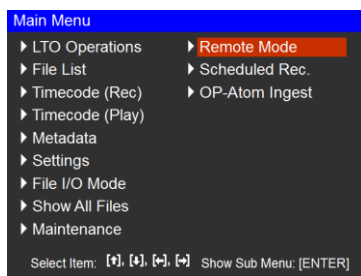

- Operation cannot be changed to Remote Mode while recording is in progress.
- If there is any file open for playback, the file closes and the mode shifts to Remote Mode.

4-12. Scheduled Recording Screen

The **Scheduled Recording** screen allows you to set and display the recording schedule list. When “**Scheduled Recording**” is selected in the **Main Menu** screen, a screen such as the one shown below on the right appears.

Use the [↑] and [↓] buttons to select a schedule in the list and press the [TC] button to display the **Scheduled Recording Setting** screen.

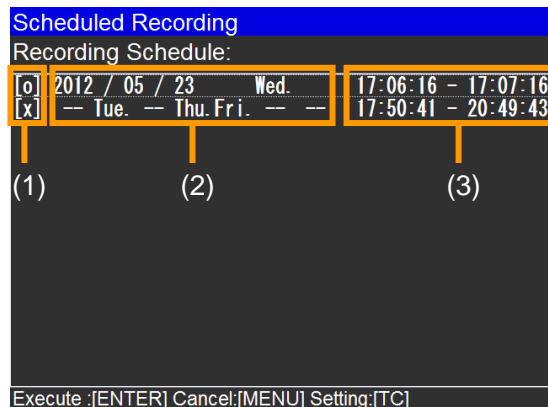
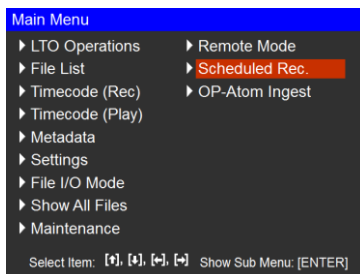

Item	Description
(1)	[o]: Schedules are active. [x]: Schedules are inactive.
(2)	Recording date Specific date: yyyy/mm/dd(dddd) Weekly recording: (dddd)
(3)	Recording start time - Recording end time

4-12-1. Setting / Editing Recording Schedules

◆ To Add New Schedules

Press the [TC] button in the **Scheduled Recording** screen to display the **Scheduled Recording Setting** screen. Select a weekly schedule or specific date. Refer to the table below for details on how to set schedules. After all settings are complete, press **ADD** to add a new entry to the schedule list.

◆ To Change or Delete Schedules

Use the [↑] and [↓] buttons to select a schedule in the schedule list, then press the [TC] button to display the **Scheduled Recording Setting** screen in which the selected schedule can be edited. After changes are complete, press **Modify**, then **ENTER** to update the schedule. To delete the selected schedule, press **Delete**, then **ENTER**.

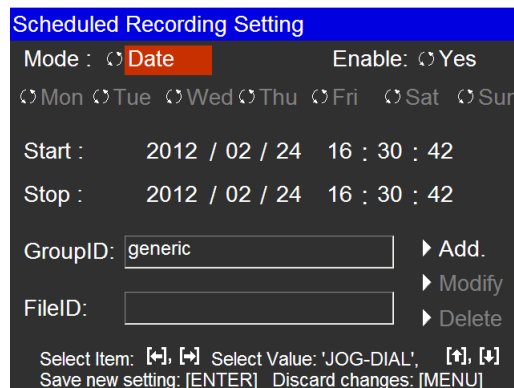

Item	Description	
Mode	Selects a weekly schedule or specific recording date.	
	Date	Sets a specific date and time.
	Weekly	Sets days of the week and time. Select days of the week under Mode from Mon / Tue / Wed / Thu / Fri / Sat / Sun.
Enable	Selects active or inactive.	
	Yes	Active (Recording schedules will be executed.)
	No	Inactive (Recording schedules will not be executed.)
Start	Sets recording start date and time. If in Weekly mode, set only start time.	
Stop	Sets recording end date and time. If in Weekly mode, set only end time.	

(Continued on next page.)

Item	Description
GroupID (*1)	Specifies GroupID.
FileID (*1)	Sets the file name. Input any character string. FileID is required if in Date mode. FileID cannot be set if in Weekly mode, because it is automatically set according to " Naming rule of MXF file. " See Sec. 4-7-1. "Recording Settings #1 screen."
Add	Adds a new schedule.
Modify	Updates the schedule modified in the Scheduled Recording screen.
Delete	Deletes the schedule selected in the Scheduled Recording screen.

*1 The following characters cannot be used for **GroupID** and **FileID**: \ \ ? * : | ~ < > . " . Up to 70 characters are allowed.

- Sufficient time intervals are required between schedule entries.

Depending on recording length or LTO drive and tape conditions, several or several tens of minutes may be required after recording to complete the process.

After changing from Playback to Recording mode or changing format in Encoder Profile, saving delays may occur in successively input recordings, and may require up to several minutes about once every 17 times.

If a period between entries in the schedule list is too short, bundle these two entries together.

- Schedule recordings longer than 24 hours cannot be performed on LTR recorders.

4-12-2. Executing/Stopping Scheduled Recordings

◆ **To Execute Scheduled Recordings**

Press [ENTER] in the **Scheduled Recording** screen to execute scheduled recordings and change the operation mode to **Scheduled Rec.** The monitoring screen display changes into **Scheduled Rec. Mode** as in the frame.

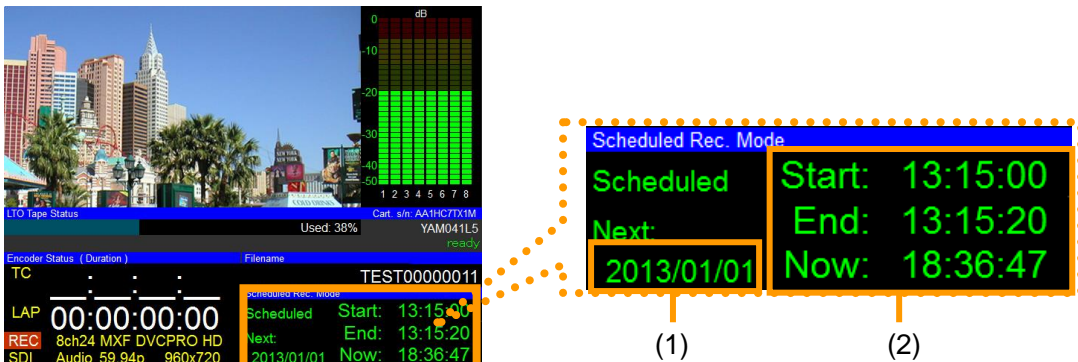

Item	Description	
(1)	Recording date	
(2)	Start	Recording start time
	End	Recording end time
	Now	Current time

In **Scheduled Rec Mode**, files cannot be played back. To play back files, press [MENU] button in **Scheduled Rec. Mode** then cancel the scheduled recording.

◆ **To Stop Scheduled Recordings**

Press [MENU] in the **Scheduled Recording** screen to stop scheduled recordings and exit **Scheduled Rec mode**.

4-13. OP-Atom to OP-1a Conversion (OP-Atom Ingest)

This screen ingests MXF files in OP-Atom format by converting them to OP-1a format and writing them on an LTO tape. MXF OP-Atom files must be uploaded to the specified folder using the FILE I/O function (FTP).

Use the [↑] and [↓] buttons or the jog dial to select an item, and use the [ENTER] or [PLAY] button to display the **Metadata** screen. When the [MENU] button is pressed, operation returns to the **Main Menu** screen.

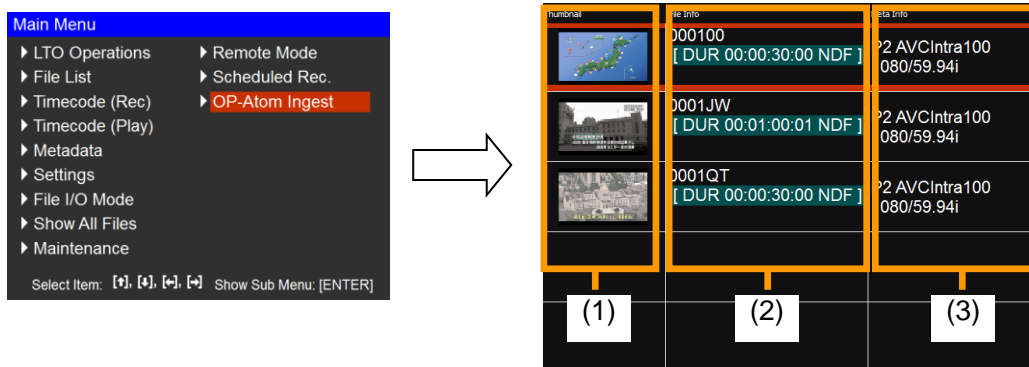

Item	Description
(1) Thumbnail	Displays thumbnails.
(2) File Info	Displays clip names and durations for MXF OP-Atom files.
(3) Meta Info	Displays media formats for OP-Atom for MXF OP-Atom files.

Converting files from OP-Atom to OP-1a format

- (1) Log in to the LTR recorder via FTP (*1).
- (2) Save the required MXF OP-Atom files to the **input** folder (*2) by uploading the "Contents" folder and all its content.
- (3) Open the **Main Menu** screen on the LTR recorder and select **OP-Atom Ingest**.
- (4) An MXF OP-Atom file list will be displayed. Select a file from the list and press [ENTER].
- (5) The **Metadata** screen will be displayed (*3). Enter the required information and press the [ENTER] button to start conversion.
- (6) A dialog as shown at right will be displayed during conversion.
To pause the process, press the [MENU] button.

Please wait until processing ends.
Push 'MENU' key to cancel.
OP-Atom to OP-1a Converting... 1%

If the process is paused, a dialog as shown at right will be displayed.
To cancel the conversion, press [ENTER].
To resume the conversion process, press [MENU] to return to the previous screen.

Convert OP-Atom to OP-1a now. Do you want to cancel it?
Please push 'ENTER' key to cancel or 'MENU' key to continue (Y...ENTER / N...MENU)

- (7) Converted MXF files can be played back in Playback mode by selecting files in the File List.

- *1 Login to upload files using user account "**metadata**". Refer to "4-8-1. FTP Clients" for details.
*2 Delete the uploaded files after the conversion has finished.
*3 Refer to "4-6. Metadata Display and Setting Screen" for details on metadata settings.

Note that the LTR recorder cannot be directly linked with an NLE or other systems in some cases.

5. Panel Descriptions

5-1. Front Panel

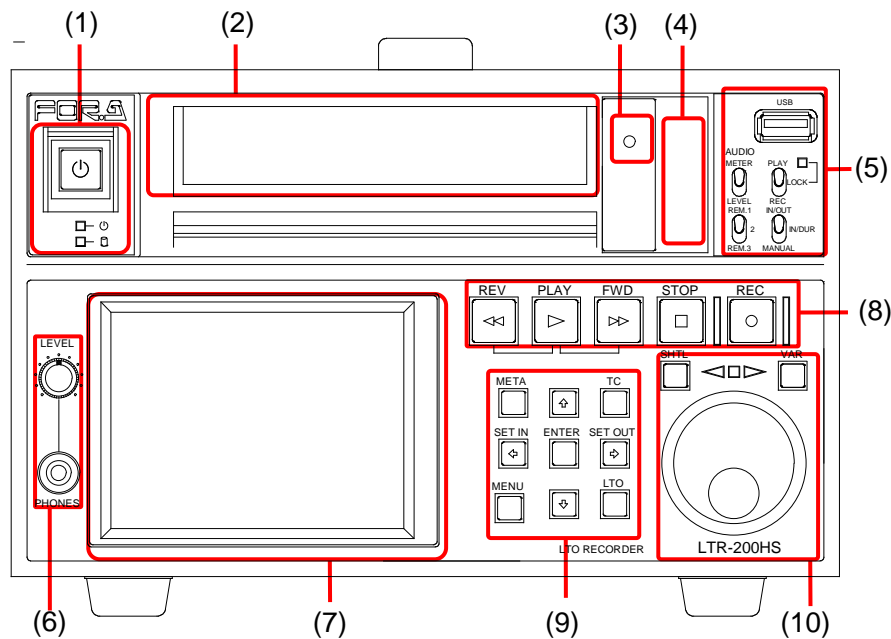

No.	Name of Part	Description
(1)	POWER button	When the POWER button is pressed, the power of the system is turned on, and the button lights up green. When the button is pressed while the power is on, the power is turned off.
(2)	LTO tape cartridge loading slot	LTO tape cartridges are inserted into this slot.
(3)	FORCE EJECT button	Normally, do not use the FORCE EJECT button to eject an LTO tape cartridge.
(4)	Status lights	For details, refer to "5-1-1. Status Lights."
(5)	Switches	For details, refer to "5-1-2. Switches."
(6)	Phone jack and control	The sound during recording or playback can be monitored using a headphone* or internal speaker. The control knob is used to adjust the volume level. Note that when a headphone is plugged in, the internal speaker is muted.
(7)	LCD monitor	Preview images, audio level meters and other displays appear on this monitor. For details, refer to "5-1-3. Monitoring Screen."
(8)	Recording/playback control area	For details, refer to "5-1-4. Recording and Playback Control Area."
(9)	Menu control area	For details, refer to "5-1-5. Menu Control Area."
(10)	Search operation area	For details, refer to "5-1-6. Search Operation Area."

5-1-1. Status Lights

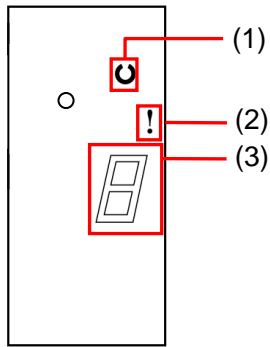

No.	Name of part	Description
(1)	Operating light	Blinks in green while data is being read from or written on the LTO tape.
(2)	Trouble light	Blinks in amber when an error has occurred.
(3)	Single-character display (SCD)	An error code is displayed here when an error has occurred. For details, refer to "Appendix A. SCD Error codes."

5-1-2. Switches

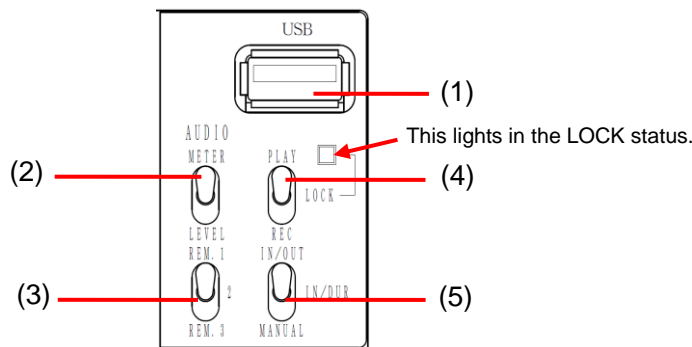

No.	Switch/Port	Setting	Description
(1)	USB		Connects the USB keyboard or USB bar code reader.
(2)	AUDIO	METER	Selects the audio meter setting (Normal or Fine).
		LEVEL	Displays the audio setting screen. In recording mode, the Audio Input Level and Channel Mapping screen appears. In playback mode, the Audio Output Level and Channel Mapping screen appears. The recording and playback volume levels for each channel and channel mapping can be changed on these screens.
(3)	REMOTE*	REM.1	Images are recorded on the VTR while the VTR is automatically controlled.
		REM.2	Images are recorded when the awaited time code is received.
		REM.3	This item is not supported by the current version.
(4)	OPERATION	PLAY	Switches from recording to playback mode.
		LOCK	Disables front panel key operation.
		REC	Switches from playback to recording mode.
(5)	REC MODE*	IN/OUT	In accordance with the specified IN and OUT points, the VTR is automatically controlled (REM.1) or the time code is awaited (REM.2).
		IN/DUR	In accordance with the specified IN point and DURATION, the VTR is automatically controlled (REM.1) or the time code is awaited (REM.2).
		MANUAL	As soon as the [PLAY] button is pressed while the [REC] button is held down, recording starts and continues for the duration specified by DURATION. If the [STOP] button is pressed while recording, recording stops.

* MANUAL takes precedence over REM.1, REM.2 and REM.3.

5-1-3. Monitoring Screen

In the **Monitoring** screen, the preview images, audio level meter, time code, lap time, recording parameters (bit rate, resolution, frame rate, number of audio channels and number of audio bits), recording filenames, IN and OUT point TCs and DURATION are displayed.

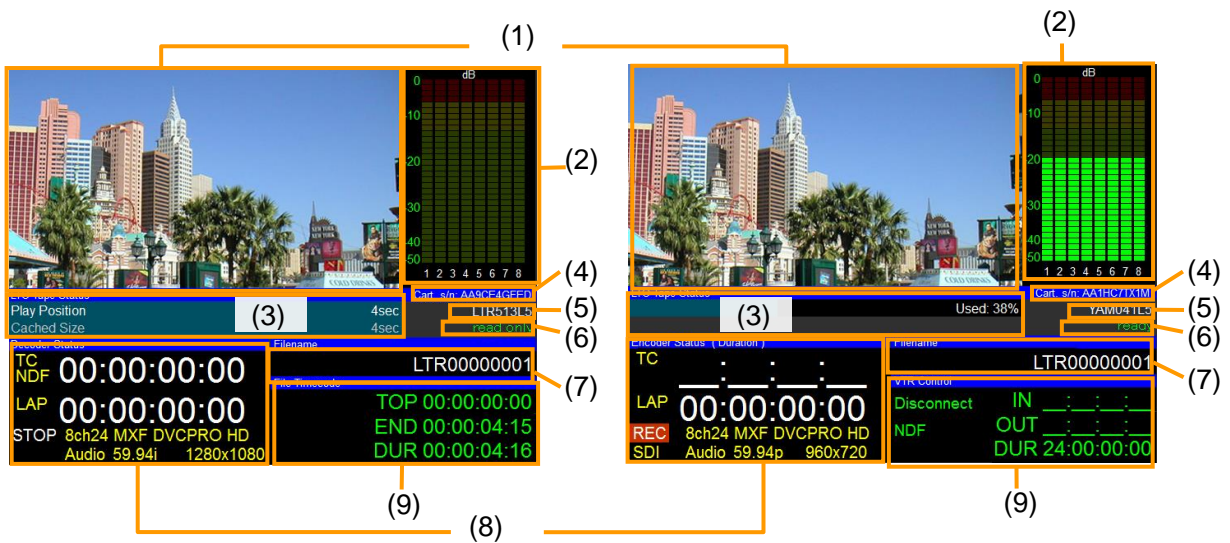

Left: playback mode; right: recording mode

No.	Item	In Playback mode	In Recording mode
(1)	Preview images (*1)	Playback images or black tint are output as preview images and concurrently output to the rear panel SDI output.	Rear panel input SDI images are displayed and concurrently output to the rear panel SDI output.
(2)	Audio level meter	Eight-channel audio peak level meter. The "Normal" or "Fine" setting can be selected using the AUDIO switch. If the Audio switch is set to "Fine", the center of the Audio reference level can be selected from -20dB, -18dB and -16dB. (For details, refer to "4-7-3. System Settings Screen".) If the Audio switch is set to "Normal", the 0 dB to -50 dB range is displayed; at the "Fine" setting, the -20 dB \pm 3 dB range is displayed. At "Normal", levels under -13.6 dB are indicated in green, levels of -13.6 dB up to -6.5 dB are indicated in yellow, and levels above -6.5 dB are indicated in red.	
(3)	Playback position display	A green horizontal progress bar appears in the upper row, representing the points from which video can be played back, and changes in relation to the copied volume of data from the LTO tape onto the cache internal hard disk. When starting playback, a white bar will appear, which indicates the current position in the video. A numeric time display right next to the bar represents the size of cached data. The bottom row is used to indicate the size of cached data. The total duration of the file is indicated numerically right next to the bar.	A "Used:X%" description indicates the total percentage of space used in the LTO tape and internal disk drive (total size of blue colored files in the file list).
(4)	Cartridge serial number	Displays the serial number of mounted LTO tape cartridge.	
(5)	Media ID display	Displays the media ID written as metadata on the mounted LTO tape.	

*1 A 16:9 aspect ratio serves as the display size so when 4:3 images are displayed, they appear in the center.

(Continued on next page)

No.	Item	In Playback mode	In Recording mode
(6)	LTO status displays	These indicate the LTO drive status.	
		no tape	The LTO tape is not mounted.
		prepare	Now preparing to mount
		mounting	Now mounting
		ready	The LTO tape has been mounted, and data can be read or written.
		unmounting...	Now unmounting
		unloading...	Now unloading the LTO tape
		error	Error status making it impossible to access the LTO drive
		formatting...	Now formatting
		recovering...	Now recovering
read only	The read-only LTO tape is mounted.		
(7)	Recording filename	Indicates the file name.	Indicates the name of the file to be saved, either during recording or with the next recording.
		The file names can be set in the Metadata Display and Setting screen. Refer to "4-6. Metadata Display and Setting Screen."	
(8)	Decoding/Encoding status	Displays the time code, lap time and recording parameters. For details, refer to "5-1-3-1. Decoding/Encoding Status."	
(9)	VTR control/ File time code	Displays the TOP and END point TCs and DURATION.	This displays the IN and OUT point TCs and DURATION.
		For details, refer to "5-1-3-2. Start and End Timecode Display."	

5-1-3-1. Decoding/Encoding Status

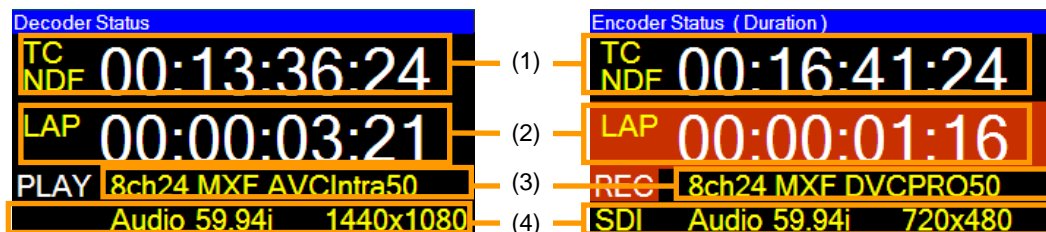

No.	Item	In Playback mode	In Recording mode
(1)	TC (*1)	Displays the time code recorded in the MXF file. Differentiation between drop frame mode and non-drop frame mode (*2) depends on what has been recorded in the MXF file.	Displays the time code in the input signal. If the input signal does have a time code, : : : is displayed. Differentiation between drop frame mode and non-drop frame mode (*2) depends on the input signal.
(2)	LAP (*3)	Displays the playback position using the start of the file as the starting point.	Displays the recording duration. During recording, the background is red.
(3)	Recording parameters	Displays the bit rate, number of audio channels and number of audio bits.	

*1 Time code is also embedded in the rear panel SDI output signals, and output.

*2 DF or NDF is displayed at 59.94i or 59.94p.

*3 In drop frame mode, the position or duration is calculated as a drop frame, and displayed.

(Continued on next page)

No.	Item	Description	
(4)	Input status displays	Displays the input signal status.	
		SDI (in recording mode)	Indicates presence of input SDI signals. A blinking of "SDI" indicates an error or failure to recognize the input signal.
		LOCK (in playback mode)	Indicates that the output has been synchronized with the genlock signal.
		Audio	Indicates presence of input audio signals.
		Frame rate	One out of 59.94i, 50i, 59.94p or 50p is displayed.
		Resolution	One out of 1920x1080, 1280x720, 1440x1080, 960x720, 1280x1080, 720x576 or 720x480 is displayed.

5-1-3-2. Start and End Timecode Display

◆ In Playback mode



No.	Item	Description
(1)	TOP point TC	Displays the start time code of the MXF file now open.
(2)	END point TC	Displays the end time code of the MXF file now open.
(3)	DURATION	Displays the playback duration of the MXF file now open.

◆ In Recording mode

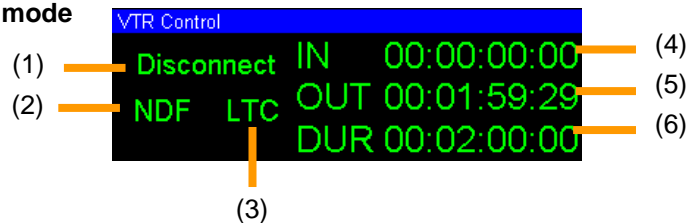

No.	Item	Description	
(1)	VTR status display	Displays VTR status when the VTR is connected via RS-422.	
		Disconnect	The VTR is not connected.
		Ejected	The tape is ejected from the VTR.
		Stop	Now stopped.
		Still	Now paused.
		Play	Now playing back.
		Fast Fwd	Now fast-forwarding
		Rewind	Now rewinding
		Record	Now recording
		Shuttle	Now operating with the shuttle ring
		Jog	Now operating with the jog dial
		Preroll	Now cueing to the preroll point.
		Editing	Now playing back the specified area.

*(Continued on next page)

No.	Item	Description
(2)	DF/NDF display	Differentiation between drop frame mode and non-drop frame mode (*1) depends on the input signal when the setting calls for the ancillary TC to be embedded. In the case of a fixed TC, the display depends on the setting in the Timecode (Rec) screen.
(3)	Time code display	When the LTC source in the Input Signal Settings screen is set to SDI ancillary , "ATC" is displayed if SDI input signal is present. When the LTC source in the Input Signal Settings screen is set to LTC IN , "LTC" is displayed if LTC input signal is present. In either case, no characters are displayed, if SDI or LTC input is not present.
(4)	IN point TC (*2)	Displays the time code at which recording starts. The setting is changed in the Timecode (Rec) screen.
(5)	OUT point TC (*2)	Displays the time code at which recording stops. The setting is changed in the Timecode (Rec) screen.
(6)	DURATION	Displays the recording duration. The setting is changed in the Timecode (Rec) screen.

*1 DF or NDF is displayed at 59.94i or 59.94p

*2 The time code fields should be left blank if recording in Manual mode.

5-1-4. Recording and Playback Control Area

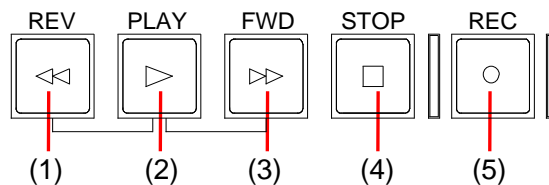

No.	Button	In Playback mode	In Recording mode
(1)	REV	Reverses (fast rewinds) the file being played back. The maximum possible reverse speed is 4x. The button is lit during reversing.	In the case of the "REM.1" setting, instructs the VTR connected using RS-422 to reverse.
(2)	PLAY	Instructs execution based on the item with [PLAY] in the menu screen. Plays back the open MXF file at normal speed. During playback, the button is lit.	Pressing [PLAY] while holding down [REC] starts recording. While recording, the button is lit. In the case of the "REM.1" setting, instructs the VTR connected using RS-422 to reverse.
(3)	FWD	Fast forwards the file being played back. The maximum possible fast forward speed is 4x. While fast forwarding, the button is lit.	In the case of the "REM.1" setting, instructs the VTR connected using RS-422 to fast forward.
(4)	STOP	Temporarily stops playback. While playback is stopped, the button is lit.	Stops recording. While recording is stopped, the button is lit. In the case of the "REM.1" setting, instructs the VTR connected using RS-422 to stop.
(5)	REC		Pressing [PLAY] while holding down [REC] starts recording. While recording, the button is lit.

5-1-5. Menu Control Area

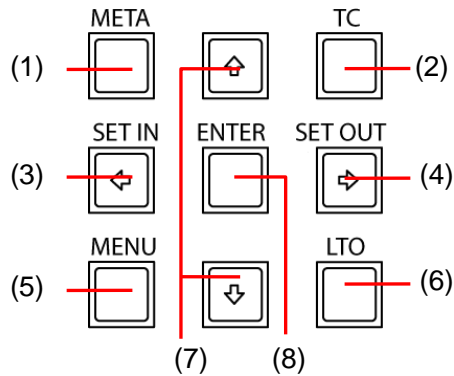

No.	Button	In Playback mode	In Recording mode
(1)	META	Displays the Metadata screen. When the button is pressed in the Metadata screen, any changes that have been made are canceled, and operation returns to the Monitoring screen.	
(2)	TC	Displays the Timecode (Play) screen. When the button is pressed in the Timecode (Play) screen, any changes that have been made are canceled, and operation returns to the Monitoring screen.	Displays the Timecode (Rec) screen. When the button is pressed in the Timecode (Rec) screen, any changes that have been made are canceled, and operation returns to the Monitoring screen.
(3)	SET IN/←	Used to move between screens.	
		Play jumps back by the time equivalent to the interval specified by Jump Distance in the Timecode (Play) screen.	The time code at the point when the button is pressed is set as the IN point.
(4)	SET OUT/→	Used to move between screens.	
		Playback jumps ahead by the time equivalent to the interval specified by Jump Distance in the Timecode (Play) screen.	The time code at the point when the button is pressed is set as the OUT point.
(5)	MENU	Displays the Main Menu. For details, refer to “4-1. Main Menu Screen.” The button is also used to return to the Monitoring screen from the Main Menu screen.	
(6)	LTO	When an LTO tape is not mounted, displays the LTO Operations screen. When an LTO tape is mounted, displays the file list screen. For details, refer to “4-2. LTO Operations Screen” and “4-3. File List Screen.”	Displays the LTO Operations screen. Refer to “4-2. LTO Operations Screen.”
		The LTO button lights up while an LTO tape is mounted. The File List or LTO Operations screen is displayed, pressing the [LTO] button cancels the screen and restores the Monitoring screen.	
(7)	↑ / ↓	In the setting screen, etc., these buttons are used to move between items and to change the setting values.	
(8)	ENTER	Executes the selections and applies changes on screen.	

5-1-6. Search Operation Area

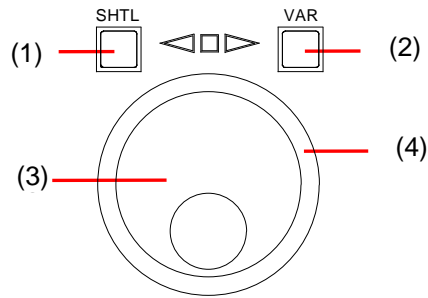

No.	Item	In Playback mode	In Recording mode
(1)	SHTL	Press this button to switch into shuttle mode. In shuttle mode, the SHTL button is lit.	
(2)	VAR	Press this button to switch into variable mode. In variable mode, the VAR button is lit.	
(3)	Jog dial	Used to change settings ^(*1) with a ↻ in the Settings screen.	
		Advances the display position of the MXF file being played one frame at a time (when turned clockwise), and returns the position one frame at a time (when turned counterclockwise).	The "REM.1" setting instructs the VTR connected using RS-422 to perform jog operations.
(4)	Shuttle ring ^(*2)	Used to play the MXF file being played back at a variable speed. When rotated clockwise, the file is played in the forward direction; when rotated counterclockwise, it is played in the reverse direction. In shuttle mode, it plays at speeds ranging from 0.5x to 4x in the forward direction and from 0.5x to 4x in the reverse direction. In variable mode, the playback speed varies from 0.1x to 1.2x depending on the angle to which the ring is rotated.	The "REM.1" setting instructs the VTR connected using RS-422 to perform shuttle operations.

*1 ↻ signifies that the setting can be changed using the jog dial.

*2 No audio is output for MPEG-2 MXF files played at 3x or 4x speed in reverse or 4x speed in the forward direction.

5-2. Rear Panel

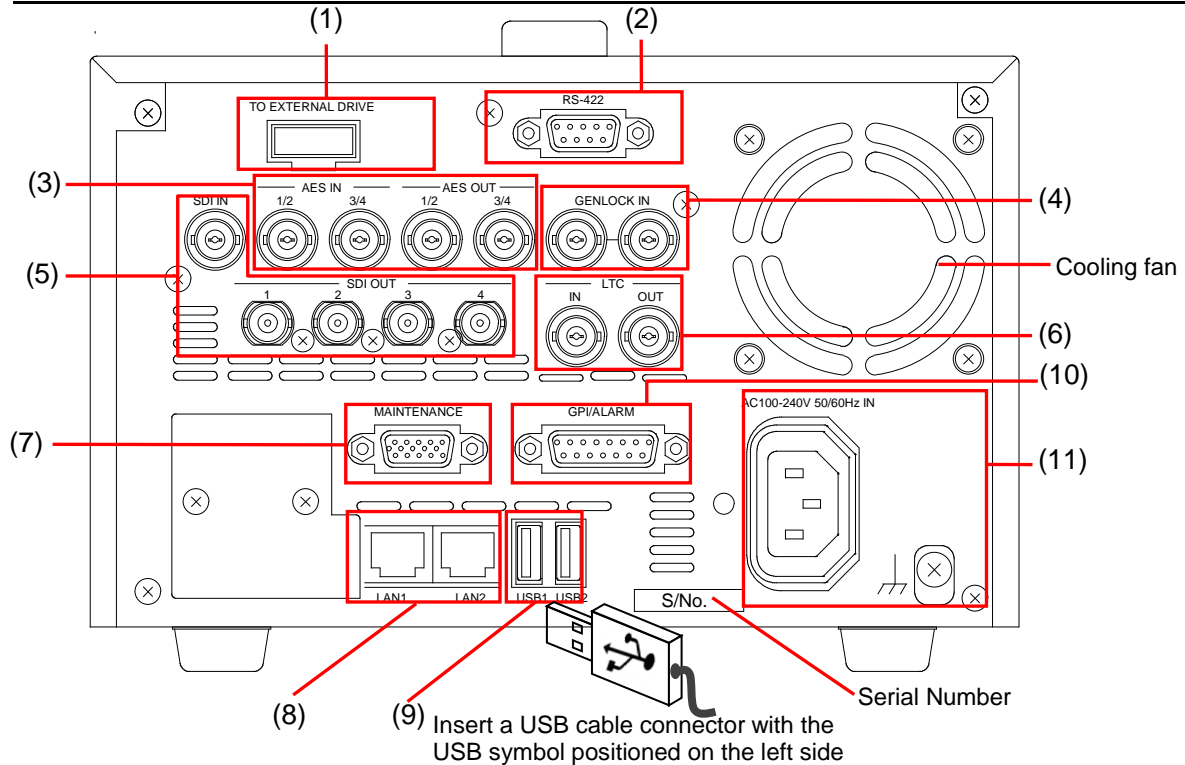

No.	Name of part	Description
(1)	LTO drive connection area	Not used.
(2)	RS-422 connector	This connector is connected to the REMOTE (9-pin) connector on the VTR when an external VTR is to be controlled. When it is used, set the front panel switch to REM.1 .
(3)	Digital audio input/output area	For details, refer to "5-2-1. Digital Audio Input/Output Area."
(4)	GENLOCK input connector	This connector is connected to the sync signals serving as the reference for the outputting SDI signals. This connector has nothing to do with the SDI input.
(5)	SDI input/output area	For details, refer to "5-2-2. SDI Input/Output Area."
(6)	LTC input/output area	For details, refer to "5-2-3. LTC Input/Output Area."
(7)	MAINTENANCE connector	This connector is used for maintenance purposes.
(8)	LAN connector	Used to input/output files and input/output metadata. LAN1 is connected to the PC via a switching hub. Do not use LAN2 , which is for maintenance use only.
(9)	USB connector	The USB keyboard or USB bar code reader is connected here.
(10)	GPI/ALARM	Alarm: Power supply, fan alarm (contact output) GPI: 3-input/3-output (contact input, open collector output) For details, refer to "5-2-5. GPI/ALARM."
(11)	Power supply area	For details, refer to "5-2-6. Power Supply Area."

IMPORTANT

Carefully insert USB connectors when connecting USB devices such as a USB keyboard and barcode reader to the USB ports on the rear panel. The "USB symbol" on the cable connector should be facing left as shown in the figure above. Otherwise, a malfunction due to USB connector damage or short-circuiting may occur.

5-2-1. Digital Audio Input/Output Area

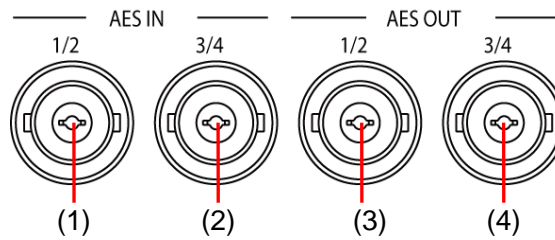

No.	Name of part	Description
(1)	AES IN 1/2	AES digital audio signals are input here. When this connector is used, set Audio source in the Input Signal Settings screen to AES IN .
(2)	AES IN 3/4	AES digital audio signals are input here. When this connector is used, set Audio source in the Input Signal Settings screen to AES IN .
(3)	AES OUT 1/2	AES digital audio signals are output from here. The same signals as the SDI output audio signals are always output.
(4)	AES OUT 3/4	AES digital audio signals are output from here. The same signals as the SDI output audio signals are always output.

5-2-2. SDI Input/Output Area

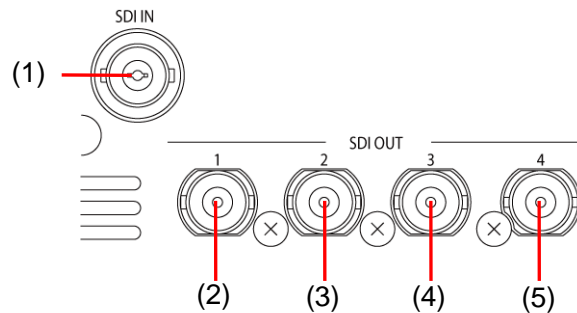

No.	Name of part	Description
(1)	SDI IN	HD-SDI signals are input here. The system operates in Input Lock mode when recording.
(2)	SDI OUT 1	HD-SDI signals are output from here. The same images and sound are output to SDI OUT1, SDI OUT2, SDI OUT3 and SDI OUT4.
(3)	SDI OUT 2	HD-SDI signals are output from here. The same images and sound are output to SDI OUT1, SDI OUT2, SDI OUT3 and SDI OUT4.
(4)	SDI OUT 3	HD-SDI signals are output from here. The same images and sound are output to SDI OUT1, SDI OUT2, SDI OUT3 and SDI OUT4. The time code is superimposed by a setting onto the SDI OUT3 and SDI OUT4 signals. ^{(*)1}
(5)	SDI OUT 4	HD-SDI signals are output from here. The same images and sound are output to SDI OUT1, SDI OUT2, SDI OUT3 and SDI OUT4. The time code is superimposed by a setting onto the SDI OUT3 and SDI OUT4 signals. ^{(*)1}

*1 To superimpose the time code, set **Show TC on screen** in the **System Settings** screen to **ON**.

5-2-3. LTC Input/Output Area

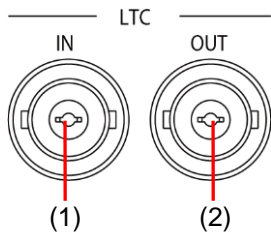

No.	Name of part	Description
(1)	LTC IN	LTC signals are input here. When this connector is used, set LTC source in the Input Signal Settings screen to LTC IN .
(2)	LTC OUT	LTC signals are output from here. The same signals as the ATC (Ancillary Timecode) of the SDI output are always output.

5-2-4. RS-422

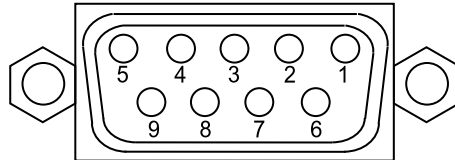

9pin D-sub female (inch screws)

◆ Pin Assignments

Pin No.	Signal	In/Out	Description
1	FG	-	Frame ground
2	Tx-	Out	Transmit Data-
3	Rx+	In	Receive Data+
4	SG	-	Signal ground
5	NC	-	No connection
6	SG	-	Signal ground
7	Tx+	Out	Transmit Data+
8	Rx-	In	Receive Data-
9	FG	-	Frame ground

◆ Wiring Diagram for RS-422 Connection Cable

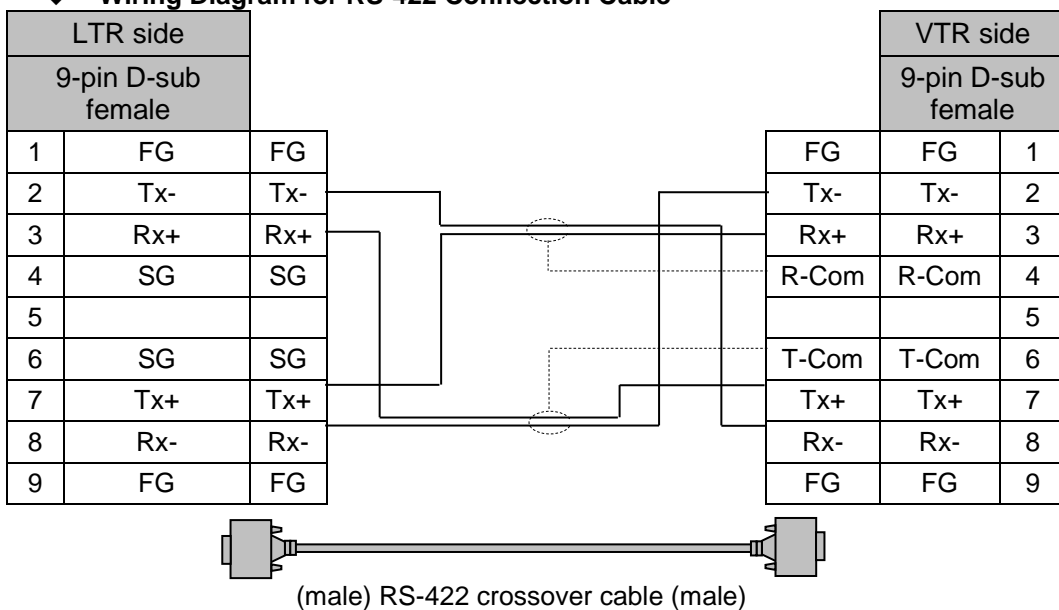

- * Use twisted pair cables for Tx and Rx connections if long cables are required.
- * Do not connect between FG and FG.
- * When using shielded cables, connecting T-Com and R-Com to the Tx and Rx shields respectively is recommended.

5-2-5. GPI/ALARM

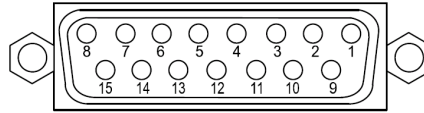

15pin D-sub female (inch screws)

◆ Pin Assignments

Pin No.	Signal	In/Out	Description
1	GND	—	Ground (0V)
2	POW ALARM	Out	Power alarm ^(*1)
3	FAN ALARM	Out	Fan alarm ^(*1)
4	NC	—	Not connected
5	GPI IN3	In	GPI input ^(*2)
6	GPI IN2	In	GPI input ^(*2)
7	GPI IN1	In	GPI input ^(*2)
8	+5VOUT	Out	+5 V output ^(*3)
9	COMMON	—	Power alarm, fan alarm common ^(*1)
10	NC	—	Not connected
11	NC	—	Not connected
12	GPI OUT3	Out	GPI output ^(*4)
13	GPI OUT2	Out	GPI output ^(*4)
14	GPI OUT1	Out	GPI output ^(*4)
15	GND	—	Ground (0V)

*1: Refer to “Alarm output circuit” below.

*2: Refer to “GPI input circuit” below.

*3: The maximum current supplied with a +5 V output is 200 mA.

*4: Refer to “GPI output circuit” in the next page.

◆ Alarm output circuit

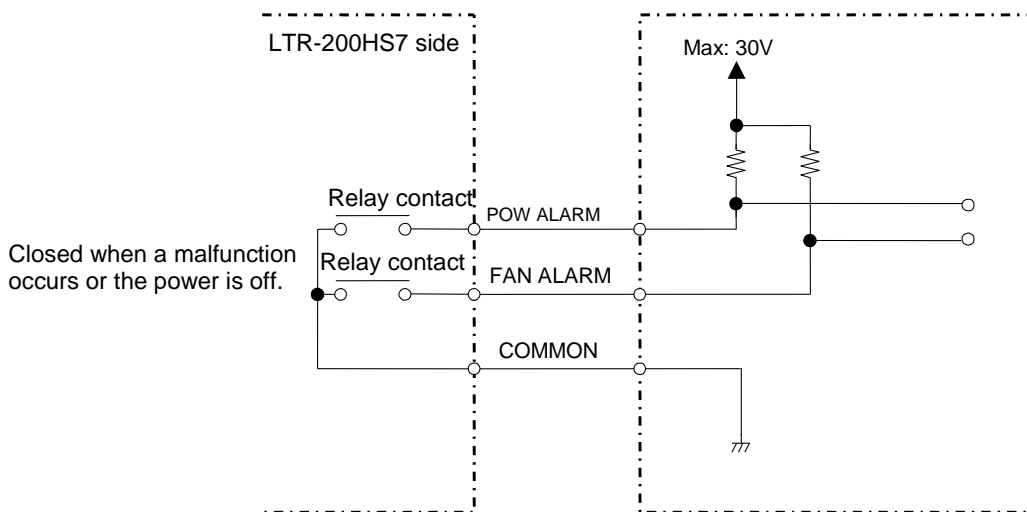

◆ GPI input circuit

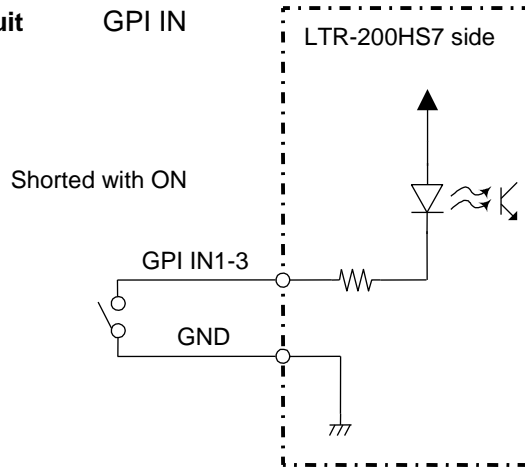

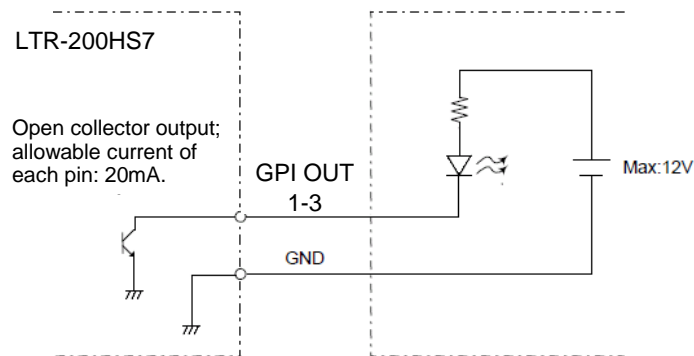

◆ GPI output circuit

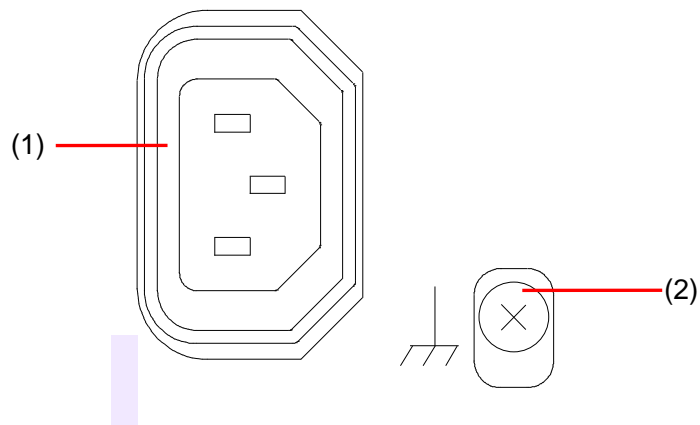

5-2-6. Power Supply Area

AC100-240V 50/60Hz IN



No.	Name of part	Description
(1)	AC100-240V 50/60Hz IN	AC power socket. Voltage from AC 100V to 240V is connected here. To ensure safety and stable operation, a grounded outlet must be used or the LTR recorder must be grounded using the ground terminal.
(2)		Ground terminal

6. Troubleshooting

No.	Symptom	Remedial action
1.	"LTO driver has a problem" message appears at startup.	<ol style="list-style-type: none"> (1) Press the [ENTER] button to return to the regular screen. (2) Select "Mount LTO Tape" on the LTO Operation screen, and try mounting the LTO tape. <ul style="list-style-type: none"> • When it is possible to mount the cartridge, return to normal operation. • When it is not possible to mount the cartridge: <ul style="list-style-type: none"> • If the "no tape" message appears →Try the remedial action suggested in Nos. 3 to 5, below. • If the "LTO driver has a problem" message appears →Shutdown the unit following the procedure in section 2-3-2. "Turning the Power Off" and then restart the unit. (3) If the problem cannot be remedied, contact the FOR-A Service Center.
2.	Mounting takes longer than before.	<ul style="list-style-type: none"> • If mounting takes longer than before after a tape data recovery. <ol style="list-style-type: none"> (1) Unlock the tape write protection and remount the LTO tape. (2) Once the tape is mounted, go to the Maintenance screen > LTO driver maintenance > LTO Driver Maintenance. (3) Execute "Repair slow mounting LTO tape". (4) If the problem cannot be remedied, contact the FOR-A Service Center.
3.	The cartridge cannot be mounted and the following error message appears. "LTFS-formatted medium is inserted, but the data has inconsistencies..."	<ul style="list-style-type: none"> • Occurs when an LTO is improperly ejected after writing. <ol style="list-style-type: none"> (1) Execute "Recover LTO tape" in the LTO Operations screen. (2) If mounting takes a long time, execute a "Repair slow mounting LTO tape" procedure (see No. 2 above). (3) If the problem cannot be remedied, contact the FOR-A Service Center.
4.	The cartridge cannot be mounted and the following error message appears. "Failure to mount the tape. The tape may be unformatted or have a bad index."	<ul style="list-style-type: none"> • If the tape is unformatted: Format the tape. (See section 2-4-3. "Formatting an LTO Tape Cartridge.") • If the tape is formatted: <ol style="list-style-type: none"> (1) Execute "Recover LTO tape" in the LTO Operations screen. (2) If mounting takes a long time, execute a "Repair slow mounting LTO tape" procedure (see No. 2 above). (3) If the problem cannot be remedied, contact the FOR-A Service Center.

No.	Symptom	Remedial action
5.	<p>The cartridge cannot be mounted and the “mounting...” dialog is not displayed.</p> <p>* If the “LTO driver has a problem” message appears, perform the steps beginning with (4) as necessary.</p>	<ol style="list-style-type: none"> (1) Select “LTO driver maintenance” in the Maintenance Menu screen to transfer to the LTO Driver Maintenance screen. (2) Execute “Force unmount LTO tape.” (3) Return to the LTO Operation Menu screen, select “Mount LTO tape” again, and try remounting the tape. <ul style="list-style-type: none"> • If the cartridge is able to be mounted, return to normal operation. (4) If the cartridge is still unable to be mounted, shutdown the unit following the procedure in Sec. 2-3-2. "Turning the Power Off." (5) Execute "Mount LTO tape" again after the unit reboots. <ul style="list-style-type: none"> • If it is possible to mount the cartridge, return to normal operation. (6) If the problem cannot be remedied, contact the FOR-A Service Center.
6.	<p>The input images are not displayed in the LCD screen.</p>	<ol style="list-style-type: none"> (1) If Playback mode is established, change to Recording mode. (2) Mount an LTO tape, if no tape is mounted. (3) If the images do not appear in Recording mode either, check the display of the “SDI” indicator at the bottom left of the screen. If “SDI” is blinking, a mistake may have been made in the SD/HD image settings. <ul style="list-style-type: none"> • If HD has been selected as the Encode Profile setting in the Setting screen, change to SD; conversely, if SD has been selected, change to HD. (For details on the setting method, refer to “4-7-2. Recording Settings #2 Screen.”) <div style="border: 1px solid black; padding: 2px; margin: 5px 0;"> <p>Attention: Verify the correct frequency setting.</p> </div> <p>* If there are no input SDI signals, the SDI field of the Signal status display in the Setting > Input signal settings screen will be white, and the Unlock display will appear. If input SDI signals are present, SDI IN will be displayed in green. If the settings and input correspond, Lock will be displayed on the left of SDI IN. (For details, refer to “4-7-4. Input Signal Settings Screen.”)</p> <ol style="list-style-type: none"> (4) If the problem cannot be remedied, contact the FOR-A Service Center.
7.	<p>A file cannot be opened.</p>	<ul style="list-style-type: none"> • If the file cannot be opened even when an attempt is made to play back files on the LTO tape: <ol style="list-style-type: none"> (1) Switch the mode from playback to recording, and then back from recording to playback. (2) Try opening the file again. (3) If the file fails to open, first unmount the LTO tape, and then execute Restart GUI on the Maintenance menu. (4) Mount the LTO tape, and try reopening the file. (5) If the problem cannot be remedied, contact the FOR-A Service Center.

No.	Symptom	Remedial action
8.	The VTR cannot be controlled during recording.	<ul style="list-style-type: none"> • If the VTR cannot be controlled in recording mode, check the VTR control display. <ol style="list-style-type: none"> (1) If the “disconnect” message is displayed, a defective 9-pin cable* may be to blame. <ul style="list-style-type: none"> * Use a crossover cable which is meant exclusively for the VTR. Do not use a crossover cable which is meant for use with a PC. (2) If “local” is displayed, there is nothing wrong with the connections, but it means that the VTR has not been set to REMOTE mode. Set the VTR to REMOTE mode. (3) If the problem cannot be remedied, contact the FOR-A Service Center.
9.	When recording at the REM.1 setting, the VTR can be automatically controlled but recording does not start at the IN point.	<ul style="list-style-type: none"> • If, when recording at the REM.1 setting, the VTR can be automatically controlled but recording does not start at the IN point, the ancillary time code may not be present in the SDI signals. This symptom occurs with digital β-cam VTRs, etc. <ol style="list-style-type: none"> (1) Select settings to input the LTC output signals from the VTR to the LTR recorder and to use LTC signals. (For details on the setting method, refer to “4-7-4. Input Signal Settings Screen.”)
10.	When recording at the REM.2 setting, recording does not start at the IN point.	<ul style="list-style-type: none"> • If, when recording at the REM.2 setting, recording does not start at the IN point, the ancillary time code may not be present in the SDI signals. This symptom occurs with digital β-cam VTRs, etc. <ol style="list-style-type: none"> (1) Select setting to input LTC output signals from the VTR to the LTR recorder and to use LTC signals. (For details on the setting method, refer to “4-7-4. Input Signal Settings Screen.”)
11.	When recording at the MANUAL setting, recording ends even when STOP is not pressed.	<ul style="list-style-type: none"> • If, when recording at the MANUAL setting, recording ends even when STOP is not pressed, a short time interval may have been selected for the DURATION. During MANUAL recording, recording will continue for the time specified by DURATION. For an operation in which the [STOP] button is pressed to stop recording, select a sufficiently long time setting for DURATION.
12.	Input video time code is not displayed.	<p>If no time code is displayed on the screen although input video has time code data, verify that the LTO tape is correctly mounted. Time codes in input video are displayed only when LTO tapes are properly mounted.</p>
13.	“C” is displayed in the SCD (next to the LTO drive).	<p>If a <input type="checkbox"/> appears on the Single-character Display after ejecting a tape, the LTO drive needs head cleaning. Insert the cleaning cartridge in to the tape drive. The drive automatically cleans and ejects the cartridge when cleaning has finished.</p> <ul style="list-style-type: none"> • The maximum number of cleanings is defined for cleaning tapes. If the number of cleanings for a tape has been exceeded, the tape will be ejected immediately. Prepare a new cleaning tape. • Although LTO tapes can be read or written while a “C” indication is displayed, clean the drive head as fast as possible because errors are likely to occur. • Regular cleaning of the drive head is not recommended. Clean the head only when a “C” appears on the SCD.

No.	Symptom	Remedial action
14.	While reading or writing to an LTO tape cartridge, the tape automatically ejects and immediately inserts itself into the drive.	While reading or writing to an LTO tape cartridge, the tape cartridge may automatically eject and immediately reinsert itself into the drive, due to the presence of small dust particles or other reasons and is not an error but a normal process. In such case, tape writing will still be correctly performed using the disk cache, even if it requires more time.
15.	If the system has shut down or the power has been turned off while an LTO tape is still in the LTO drive	(1) Turn on the power of the LTR recorder. (2) The light in the SCD comes on as described below: <ol style="list-style-type: none"> 1. The light comes on, and the number “8” is drawn. 2. The number “8” is displayed. 3. After 1. and 2. are repeated for a short while, the number displayed as “8” counts down, and eventually “0” is displayed. 4. The light goes off, and nothing is displayed in the SCD. 5. Now press the [FORCE EJECT] button to unload the LTO tape. <div style="border: 1px solid black; padding: 5px; margin: 10px 0;"> <p>Attention: It may take up to 10 minutes to reach the stage where nothing is displayed on the SCD in step 4.</p> </div> (3) If the problem cannot be remedied, contact the FOR-A Service Center.
16	When the front panel buttons cannot be operated	When the front panel buttons cannot be operated, the power-off process for shutdown will not be executed even if the front panel [Power] button is pressed. In such case such case, check that the bottom LED of the two LEDs under the front panel [Power] button is not blinking, and unplug the power cord on the rear panel. If the problem is not remedied after restarting the unit, contact the FOR-A Service Center.
17	Cannot eject LTO tape from drive.	(1) Verify that the LTO tape is mounted. If not, mount the LTO tape. (See section 2-4-1. “Inserting and Mounting a Tape Cartridge.”) (2) Select “Eject LTO tape” in the LTO Operations screen to eject the tape. (See section 2-4-2. “Unloading an LTO Tape Cartridge.”) (3) If the tape cannot be ejected, execute a “Force unmount LTO tape” procedure in the LTO Driver Maintenance Menu Screen (see section 4-10-1). (4) If the LTO tape still cannot be ejected, press and hold down the FORCE EJECT button. When the SCD display is turned on, release the button and wait until the LTO tape is ejected from the drive. (5) If the problem cannot be remedied, contact your FOR-A reseller.
18.	“6” or “7” is displayed in the SCD (next to the LTO drive).	Re-mount the tape. An error code (6 or 7) displayed while recording indicates that recorded video has been incorrectly written to the LTO tape and stored in the internal hard disk drive, and is displayed in blue in the file list. The recorded video can be written to another LTO tape. Refer to “Appendix A “SCD Error Codes” for details on SCD errors.
19.	Cannot read MXF files in another system.	If an MXF file created in the device cannot be read in an NLE or other system, set Embed DMS-1 Metadata in MXF file to OFF in section 4-7-1. “Recording Settings #1” before recording and reload a new MXF file.

7. Restrictions

7-1. Recording

Details of restrictions	Related section no.
Recorded MXF files are written onto the LTO tapes as they are being recorded, but writing may take some more time even after recording is completed. Proxy files are not written as they are being recorded but are written after MXF files have been written. The next recording cannot be started unless the writing is completed.	4-3-1
Recording across multiple LTO tapes are not possible.	
Recording stops when there is no more free space on an LTO tape.	
When recording in REM.1 mode, be sure to check that there is enough time for pre-roll before the IN point. Otherwise, the IN point may be set incorrectly or recording may not start due to the pre-roll failure. Refer to "VTR Control Settings" in the "4-10-3. Interface and System Setting Menu Screen" for details on the pre-roll time setting.	4-10-3
<p>Available VTR commands (Sony 9-pin protocol, RS-422 connection) are shown in the table below.</p> <ul style="list-style-type: none"> ● LOCAL DISABLE ● LOCAL ENABLE ● STOP ● PLAY ● EJECT ● FAST FWD ● REWIND ● JOG FWD ● SHUTTLE FWD ● JOG REV ● SHUTTLE REV ● PREROLL ● CUE UP WITH DATA ● PREVIEW ● TIMER-1 PRESET ● TIMER MODE SEL ● CUR TIME SENSE ● STATUS SENSE 	
If "Timecode in file" is set to Ancillary TC or LTC and the ancillary time code disappears during recording, the recording process may stop in some cases.	
The Monitoring screen, built-in speaker and headphone out are provided only for monitoring use and to ensure easy operation. To precisely check the audio and video quality, use appropriate devices by connecting them to the rear of the unit. In recording mode, signal timing differs between the built-in speaker or headphone and SDI audio.	
On rare occasions, the sound heard through headphones or speakers may skip. This does not affect the SDI or AES sound.	
Do not make a loop connection such as by connecting SDI IN and SDI OUT directly at startup, which may result in malfunction or failures and inputs may not be accepted. The device can be recovered by changing the encode profile but may malfunction again when switching between REC and PLAY.	
When recording in REM.1 mode, the recording may stop if time code on the video source is discontinuous , or be interrupted if the VTR returns Lost Lock messages for more than two frames. This is because, in these cases, Master mode cannot correctly specify the IN and OUT points for recording. To properly record the video, change the mode to Manual .	
<p>Do not change write protect On/Off switches while LTO tapes are inserted in the LTR recorder. Doing so may cause significant errors in some cases, such as recording failures or missing recorded files.</p> <p>Be sure to eject LTO tapes from the LTR recorder before changing the write protect switch status.</p>	

Details of restrictions	Related section no.
The TC field in Encoder Status may be blank in some cases if time code is not included in input.	5-1-3-1
After changing from Playback to Recording mode or changing the format in Encoder Profile, if input signal is recorded consecutively, saving delay may occur once every 17 times and may require up to several minutes for saving.	
Changing the OPERATION switch to PLAY during recording locks the front panel operation (the same state as setting OPERATION to LOCK). The operation mode returns to PLAY after recording is finished.	5-1-2
Recording using REM.1 may fail in some VTR devices if the playback position is placed at the top or end of tapes. In REM.1 mode, do not specify IN- or OUT-points that do not exist in tapes.	5-1-2
Depending on recording length or LTO drive and tape conditions, it may take several or several tens of minutes after recording to complete the process. Sufficient time intervals are required between schedule entries in the Recording Schedule list.	4-12
If " 24:00:00:00 " is displayed under Duration in IN/OUT recording mode after setting IN and OUT points, the last frame will not be recorded. To record video for 24 hours when IN point is fixed, use IN/DUR mode.	4-4, 5-1-2
When VITC and LTC timecodes are both embedded in SDI signals, the VITC timecode will be displayed on the SDI OUT3 and 4 output video, even if the LTC source is set to SDI ancillary (LTC) . * Note that in such cases, the LTC timecode will be recorded and displayed on the Monitoring screen.	4-7-3
Writing retry operations may occur depending on LTO tape or head conditions and reduce the amount of available free space on tapes. This happens because the read head, which follows the write head, verifies just written data and rewrites the data in another area if an error is detected. Many writing errors, therefore, involve a reduction in free space. This is not a malfunction but a normal feature.	
Writing retry operations may occur by rewinding the tape with the tape automatically ejecting and immediately reinserting into the drive in some cases, and may take several minutes to complete. In such case, do not forcibly remove the tape from the drive while the tape is temporarily ejected.	
Although some data in time code or LAP may seem to be lost on the front panel display, they are continuously recorded even if they are incorrectly being displayed.	
When recording SD video images input from a VTR using an LTR-PD-SD option, the images may appear distorted and the bottom area may appear blackish. In such cases, use a frame synchronizer to adjust SDI signals before inputting in the LTR.	

7-2. Playback

Details of restrictions	Related section no.
Cache erase operations cannot be performed for an open file that is playing back. To perform cache erase, switch the mode from playback to recording, and close the file.	4-3-1
For the playback of MXF files, basically only files created on the LTR recorder are supported. But the customers can consult us on this matter.	
When playing back MXF files at variable speeds (faster or slower than normal speed), the Player may stop while displaying a frozen video. In this case, close and re-open the file, then play the file again. This phenomenon will be improved in future versions.	
When playing back MXF files at variable speeds (faster or slower than normal speed), the top or last frame may not play back in some cases.	
The preview screen, built-in speaker and headphone out are provided only for monitoring use and to ensure easy operation. To precisely check the audio and video quality, use appropriate devices by connecting them to the rear of the unit.	
On rare occasions, the sound heard through headphones or speakers may skip. This does not affect the SDI or AES sound.	
Although this is a characteristic of LTO tapes, in some cases, the tape drive may rewind tapes to read them. The tape cartridge may automatically eject and immediately reinsert into the drive during writing retries. In such case, the process may take several minutes. Or playback may continue until the end of the cached data and stop due to the caching.	
Do not change write protect On/Off switches while LTO tapes are inserted in the LTR recorder. Doing so may cause significant errors in some cases, such as failed playback or missing recorded file. Be sure to eject LTO tapes from the LTR recorder before changing the write protect switch status.	
Turning the jog dial slowly may make the dial inactive once every approximately 50 to 100 frames.	3-2 5-1-6
In some cases, the "REV" may not rewind tapes back to the top position but to the position that is two-frames advanced.	3-2, 5-1-4
In some cases, normal playback may advance audio or time code by one frame.	
No audio is output for MPEG-2 MXF files played at 3x or 4x speed in reverse or 4x speed in the forward direction.	

7-3. Miscellaneous

Details of restrictions	Related section no.
When a setting other than "Free run" has been selected for the Reference input format, MXF files with a frequency different from the genlock frequency are unable to be opened. If an attempt is made to open such a file, a warning is displayed, and the file will not be opened. If "Free run" has been set, MXF files can be opened regardless of the frequency.	4-7-3
"192.168.255.xxx" cannot be set as the IP address. If an attempt is made to set the address, an error message is displayed.	4-10-3

7-4. Supported LTO Tape

Details of restrictions		Related section no.															
LTO-3 and LTO-4 tapes are not supported.																	
LTO tapes written in the TAR format are not supported.																	
1MB or larger file-size thumbnails will not show in the File List. If you create thumbnails outside the LTR-200HS7, be sure to keep the file size smaller than 1 MB.																	
<p>When recording with some codecs, the timecode data is incremented continuously from the start timecode. Therefore, discontinuous timecode may not be recorded properly. See the table below for discontinuous TC recording/playback availability for each codec.</p> <table border="1"> <thead> <tr> <th>Codecs</th> <th>Discontinuous TC recording</th> <th>Discontinuous TC playback</th> </tr> </thead> <tbody> <tr> <td>MPEG-2</td> <td>Available</td> <td>Available</td> </tr> <tr> <td>AVC-Intra/DVCPRO</td> <td>Available</td> <td>Available</td> </tr> <tr> <td>DNxHD</td> <td>Available</td> <td>Available</td> </tr> <tr> <td>ProRes</td> <td>Unavailable</td> <td>Unavailable</td> </tr> </tbody> </table>		Codecs	Discontinuous TC recording	Discontinuous TC playback	MPEG-2	Available	Available	AVC-Intra/DVCPRO	Available	Available	DNxHD	Available	Available	ProRes	Unavailable	Unavailable	
Codecs	Discontinuous TC recording	Discontinuous TC playback															
MPEG-2	Available	Available															
AVC-Intra/DVCPRO	Available	Available															
DNxHD	Available	Available															
ProRes	Unavailable	Unavailable															

8. Specifications and Dimensions

8-1. Specifications

Video Formats	HD: 1080/59.94i, 1080/50i, 720/59.94p, 720/50p
Removable Storage Device	LTO-5 / LTO-6 / LTO-7 (File system: IBM LTFS) *LTO-5 is reading only.
Supported MXF Format	<p>[OP-1a (SMPTE RDD-9)]</p> <p>HD: MPEG-2 Long GOP -50Mbps (CBR/4:2:2/422P@ML) Audio: 24bit, 8ch -35Mbps (CBR/4:2:0/MP@HL) Audio: 16bit, 4ch -25Mbps (CBR/4:2:0/MP@H14) Audio: 16bit, 4ch -18Mbps (CBR/4:2:0/MP@HL) Audio: 16bit, 4ch</p> <p>[OP-1a HD]</p> <ul style="list-style-type: none"> - AVC-Intra 100 (10-bit, 4:2:2) Audio: 24bit, 8ch - AVC-Intra 50 (10-bit, 4:2:0) Audio: 24bit, 8ch - DVCPRO HD (8-bit, 4:2:2) Audio: 24bit, 8ch - DNxHD 115 (8-bit, 4:2:2) Audio: 24-bit, 8ch - DNxHD 120 (8-bit, 4:2:2) Audio: 24-bit, 8ch - DNxHD 145 (8-bit, 4:2:2) Audio: 24-bit, 8ch - DNxHD 175 (8-bit, 4:2:2) Audio: 24-bit, 8ch - DNxHD 185 (8-bit, 4:2:2) Audio: 24-bit, 8ch - DNxHD 220 (8-bit, 4:2:2) Audio: 24-bit, 8ch - DNxHD 175 (10-bit, 4:2:2) Audio: 24-bit, 8ch - DNxHD 185 (10-bit, 4:2:2) Audio: 24-bit, 8ch - DNxHD 220 (10-bit, 4:2:2) Audio: 24-bit, 8ch
Video Input	HD-SDI: 1.5 Gbps, 75Ω BNC x 1
Video Output	HD-SDI: 1.5 Gbps, 75Ω BNC x 4 (Output 3 and 4 support timecode display)
Genlock Input	BB: 0.429 Vp-p (NTSC) /0.45 Vp-p (PAL) or Tri-level sync: 0.6 Vp-p, 75Ω BNC x 1, loop-through (Terminate with 75Ω terminator, if unused)
Audio Input	The maximum number of input channels varies according to MXF format and bitrate.
Embedded	Max. 8 ch (4 stereo pairs) (Group 1 and 2) 48 kHz, synchronous only
AES/EBU	1.0 Vp-p, unbalanced, 75Ω, BNC x 2 (2 stereo pairs), 16/20/24-bit, 48 kHz

Audio Output	The maximum number of output channels varies according to MXF format and bitrate.
Embedded	Max. 8 ch (4 stereo pairs) (Group 1 and 2) 48 kHz, synchronous only
AES/EBU	1.0 Vp-p, unbalanced, 75Ω, BNC x 2 (2 stereo pairs), 16/20/24-bit, 48 kHz
Time Code Input	
Embedded	Ancillary timecode
LTC	1.0 Vp-p, Unbalanced, 10kΩ, BNC x 1
Time Code Output	
Embedded	Ancillary timecode
LTC	1.5 Vp-p, unbalanced, 75Ω, BNC x 1
Recording Time	Minimum / file: 1 sec, Maximum / file: 24 hours
Internal Storage	8TBHDD
Interfaces	
RS-422	9-pin D-sub (female) x 1 (w/ inch screws) (for external VTR control on encoding)
USB	Front: 2.0 Series A connector x1 Rear: 3.0 Series A connector x2
LAN1/2	100Base-TX/1000Base-T, RJ-45 x 2
To External Drive	Mini-SAS x 1 (not used)
GPI/ALARM	15-pin D-sub (female) x 1, ALARM: Power, Fan alarm (relay contact) / GPI: 3-input/3-output (contact input, open collector output)
MAINTENANCE	15-pin mini D-sub (female) (VGA) x 1 (maintenance only)
Temperature	10°C to 40°C
Humidity	20% to 80% (no condensation)
Power	100 VAC to 240 VAC ±10%, 50/60 Hz
Consumption	170 VA (W) at 100-120 VAC 176 VA (W) at 220-240 VAC
Dimensions	212 (W) x 130 (H) x 533.5 (D) mm EIA 3 RU half size
Weight	10 kg
Consumables (if used 24 hour/day at room temperature)	
	Cooling fan: Replace every 3 years. Power supply unit: Replace every 5 years. Battery: Replace every 5 years. (*) Hard disk drive: Replace every 5 years.
Accessories	Operation manual, Tutorial manual, AC Cord (cable retaining clip included), LTO cleaning cartridge and Control software (Installed)
Options	USB keyboard, USB barcode reader and 1 year warranty

* Yearly battery replacement is recommended when unit is stored without powering on for long periods.

8-2. Proxy Video

8-2-1. H.264 File

Video	Standard	H.264 Baseline Profile Level 2.1
	Resolution	HD: 424 x 240
	Frame rate	NTSC: 29.97 fps, PAL: 25 fps
	Bit rate	900 kbps
Audio	Standard	AAC LC
	Number of channels	2 ch
	Sampling rate	16-bit, 48 kHz
	Bit rate	96 kbps
File format	Standard	MP4
	Bit rate	Auto-calculated from video and audio bitrates
Timecode	-Added to each frame as the Picture Timing SEI message in H.264 streams. -Supports discontinuous timecodes. -Timecode can be added to the video itself by changing setting.	

8-2-2. Windows Media File

Video	Standard	Windows Media Video V9
	Resolution	HD: 424 x 240
	Frame rate	NTSC: 29.97 fps, PAL: 25 fps
	Bit rate	1300 kbps
Audio	Standard	Windows Media Audio V9
	Number of channels	2 ch
	Sampling rate	48 kHz
	Bit rate	192 kbps
File format	Standard	WMV (ASF)
	Bit rate	Auto-calculated from video and audio bitrates
Timecode	-Timecode can be added to the video itself by changing setting.	

8-3. LTO-5 Basic Performance

Cartridge Size	105 (W) x 22 (H) x 102 (D) mm
Capacity	Approx. 1.5 TB (data area: 1425 GB / 1327 GiB)
Recording capacity	The following, values excluding ancillary data and proxy video files, are theoretical. Actual values may differ depending on LTO tape and head conditions.
MPEG-2 422@HL	Approx. 52 hours (50Mbps, HD)
AVC-Intra 100 (HD)	Approx. 25 hours
DNxHD 220Mbps	Approx. 11 hours
Response	File system information acquisition time: Less than 1 min in typical cases File body seek time: within 3 min

8-4. LTO-6 Basic Performance

Cartridge Size	105 (W) x 22 (H) x 102 (D) mm
Capacity	Approx. 2.5 TB (data area: 2408 GB / 2242 GiB)
Recording capacity	The following, values excluding ancillary data and proxy video files, are theoretical. Actual values may differ depending on LTO tape and head conditions.
MPEG-2 422@HL	Approx. 80 hours (50Mbps, HD)
AVC-Intra 100 (HD)	Approx. 40 hours
DNxHD 220Mbps	Approx. 18 hours
Response	File system information acquisition time: Less than 1 min in typical cases File body seek time: within 3 min

8-5. LTO-7 Basic Performance

Cartridge Size	105 (W) x 22 (H) x 102 (D) mm
Capacity	Approx. 6.5 TB (data area: 5732 GB / 5338 GiB)
Recording capacity	The following, values excluding ancillary data and proxy video files, are theoretical. Actual values may differ depending on LTO tape and head conditions.
MPEG-2 422@HL	Approx. 190 hours (50Mbps, HD)
AVC-Intra 100 (HD)	Approx. 95 hours
DNxHD 220Mbps	Approx. 42 hours
Response	File system information acquisition time: Less than 1 min. in typical cases File body seek time: within 3 min.

Warning

This equipment has been tested and found to comply with the limits for a Class A digital device, pursuant to Part 15 of FCC Rules. These limits are designed to provide reasonable protection against harmful interference when the equipment is operated in a commercial environment. This equipment generates, uses, and can radiate radio frequency energy and, if not installed and used in accordance with the instruction manual, may cause harmful interference to radio communications. Operation of this equipment in a residential area is likely to cause harmful interference, in which case the user will be required to correct the interference at his own expense.



FOR-A COMPANY LIMITED

Head Office 3-8-1 Ebisu, Shibuya-ku, Tokyo 150-0013, Japan
Overseas Division Tel: +81(0)3 3446 3936 Fax: +81(0)3 3446 1470
Japan Branch Offices Osaka/Okinawa/Fukuoka/Hiroshima/Nagoya/Sendai/Sapporo
R&D/Production Sakura Center/Sapporo Center

FOR-A Corporation of America

11155 Knott Ave., Suite G&H, Cypress, CA 90630, USA.
Tel: +1 714 894 3311 Fax: +1 714 894 5399

FOR-A Corporation of America East Coast Office

2 Executive Drive, Suite 670, Fort Lee Executive Park, Fort Lee, NJ 07024, USA
Tel: +1 201 944 1120 Fax: +1 201 944 1132

FOR-A Corporation of America Distribution & Service Center

2400 N.E. Waldo Road, Gainesville, FL 32609, USA
Tel: +1 352 371 1505 Fax: +1 352 378 5320

FOR-A Corporation of America Miami Office

8333 North West 53rd Street Suite 427 Doral, FL 33166, U.S.A
Tel: +1 305 931 1700 Fax: +1 714 894 5399

FOR-A Corporation of Canada

1131A, Leslie Street Suite 209, Toronto, Ontario M3C 2J6, Canada
Tel: +1 416 977 0343 Fax: +1 416 977 0657

FOR-A Europe S.r.l.

Via Volturmo 37, 20861 Brugherio MB, Italy
Tel: +39 039 91 64 811 Fax: +39 039 878 140

FOR A UK Limited

Trident Court, 1 Oakcroft Road, Chessington, KT9 1BD, UK
Tel: +44 (0)20 3044 2935 Fax: +44(0)20 3044 2936

FOR-A Italia S.r.l.

Via Volturmo 37, 20861 Brugherio MB, Italy
Tel: +39 039 881 086/103 Fax: +39 039 878 140

FOR-A Corporation of Korea

1007, 57-5, Yangsan-ro, Yeongdeungpo-gu, Seoul 150-103, Korea
Tel: +82 (0)2 2637 0761 Fax: +82 (0)2 2637 0760

FOR-A China Limited

708B Huateng Building, No. 302, 3 District, Jinsong, Chaoyang, Beijing 100021, China
Tel: +86 (0)10 8721 6023 Fax: +86 (0)10 8721 6033

FOR-A Middle East-Africa Office

Dubai Media City, Aurora Tower, Office 1407, P.O. Box 502688, Dubai, UAE
Tel: +971 (0)4 551 5830 Fax: +971 (0)4 551 5832

Agiv (India) Private Limited (FOR-A India)

2nd Floor, Valecha Chambers, Link Road, Andheri(W), Mumbai 400053
Tel: +91-22-26733623 Fax: +91-22-26393415