



Falcon X & Falcon D Series

Falcon X5, X6, X7, D7

(Rev. 2.0)

SUMMARY

SAFETY WARNINGS / ISTRUZIONI PER LA SICUREZZA	5		
PREFACE	6		
SAFETY WARNINGS	7		
CONSIGNES DE SÉCURITÉ IMPORTANTES	9		
ISTRUZIONI IMPORTANTI PER LA SICUREZZA	11		
WICHTIGE SICHERHEITSHINWEISE	13		
INSTRUCCIONES IMPORTANTES DE SEGURIDAD	15		
UNPACKING AND INSPECTION	17		
FIRST INSTALLATION RECOMMENDATIONS	18		
POWER SUPPLY CABLE	18		
PROTECTION AGAINST LIGHTNING	18		
VENTILATION	19		
DEVICE INSTALLATION	19		
DEVICE GENERAL DESCRIPTION	21		
FRONT PANEL	21		
REAR PANEL	22		
1. FIRST DEVICE START	24		
1.1 STARTING YOUR FALCON - QUICK SETUP	24		
1.2 LOGIN	26		
2. QUICK SETUP	28		
3. HOME PAGE/GRAPHIC VIEW	29		
3.1 AUDIO SELECTOR	32		
3.1.1 SOURCE SETTING:	32		
3.1.2 AUDIO SELECTOR MODE:	32		
3.1.3 ADVANCED AUDIO SELECTOR	33		
3.2 PROCESSING	37		
3.3 AUDIO OUTPUTS	38		
3.4 MPX OUTPUTS	40		
3.5 LOGGED IN USER – HOME PAGE/COMPACT VIEW	43		
4. SUMMARY MASK	44		
4.1 SYSTEM	46		
4.2 RDS MODULE	48		
4.3 AUDIO MODULE	51		
4.4 MPX MODULE (NOT IN FALCON D7)	53		
4.5 OUTPUT MODULE	58		
4.6 MULTIMEDIA MODULE (OPTIONAL)	59		
4.7 PROCESSOR	61		
5. MENU	64		
5.1 HOME	64		
5.2 AUDIO INPUT	65		
5.2.1 SOURCES	65		
5.2.2 AUDIO SELECTOR	76		
5.3 AUDIO OUTPUT	77		
5.3.1 DIRECT SOURCE	77		
5.3.2 ANALOG	77		
5.3.3 DIGITAL 1&2	77		
5.3.4 DIGITAL OUTPUT SETUP	78		
5.3.5 STREAMING MONITOR	78		
5.3.6 FM PROCESS	79		

5.3.7	ITU-R BS.1770 (LOUDNESS NORMALIZATION)	80	5.4.2	ADDING A NEW USER	158
5.4	PROCESS	81	5.4.3	REMOVING AN EXISTING USER.	159
5.4.1	AUTOMATIC GAIN CONTROL – AGC	81	5.5	SYSTEM SETTINGS	160
5.4.2	ENHANCER	82	5.5.1	GENERAL SETUP	160
5.4.3	COMPRESSORS	83	5.5.2	NETWORK	171
5.4.4	LIMITERS	84	5.5.3	NTP	177
5.1	MPX (NOT IN FALCON D7)	86	5.5.4	SNMP	179
5.1.1	INTERNAL MPX ENCODER	86	5.5.5	SMTP	180
5.1.2	CHANGEOVER	87	5.5.6	GPIO	182
5.1.3	OUTPUTS	95	5.5.7	GPS	185
5.1.4	MPX ANALYSIS	97	5.5.8	SYSTEM TOOLS	186
5.2	MULTIMEDIA	99	5.1	SAVE/LOAD CONFIG.	193
5.2.1	SOURCES	99	5.1.1	TO/FROM FILE	193
5.2.2	CHANGEOVER	105	5.1.2	EASY CONFIG	194
5.2.3	STREAM ENCODER	106	5.2	LOGS	203
5.3	RDS/RBDS (NOT IN FALCON D7)	112	5.2.1	USERS LOGS	203
5.3.1	UECP PORTS (UNIVERSAL ENCODER COMMUNICATIONS PROTOCOL)	112	5.2.2	EVENTS LOGS	203
5.3.2	BASIC SETTINGS	115	5.2.3	NOTIFICATIONS LOGS	203
5.3.3	STANDARD MODE	121	5.3	ASCII COMMANDS	204
5.3.4	EXTENDED MODE	146	5.3.1	ASCII PARSER (DESCRIPTION OF THE PROTOCOL)	205
5.3.5	RDS BLOCKS ANALYSIS	154	5.3.2	SYNTAX	206
5.4	USERS	155	5.3.3	COMMANDS	206
5.4.1	USER CLASS – USER RIGHTS TO LOGIN THE SYSTEM	156	6.	TECHNICAL SPECS	211
			7.	WEEE DIRECTIVE – INFORMATIVA RAE	217
			8.	WARRANTY	218

DECLARATION OF CONFORMITY – FALCON X5	219
DICHIARAZIONE DI CONFORMITA' – FALCON X5	220
DECLARATION OF CONFORMITY – FALCON X6	221
DICHIARAZIONE DI CONFORMITA' – FALCON X6	222
DECLARATION OF CONFORMITY – FALCON X7	223
DICHIARAZIONE DI CONFORMITA' – FALCON X7	224
DECLARATION OF CONFORMITY – FALCON D7	225
DICHIARAZIONE DI CONFORMITA' – FALCON D7	226

SAFETY WARNINGS / ISTRUZIONI PER LA SICUREZZA

SAFETY WARNINGS

CONSIGNES DE SÉCURITÉ IMPORTANTES

ISTRUZIONI IMPORTANTI PER LA SICUREZZA

WICHTIGE SICHERHEITSHINWEISE

INSTRUCCIONES IMPORTANTES DE SEGURIDAD

(Rel. 1.6)

PREFACE

**For your own safety and to avoid invalidation of the warranty all text marked with these Warning Symbols should be read carefully.
all the texts marked with the Warning Symbols.**



Information in this manual is subject to change without notice and does not represent a commitment on the part of the vendor. The manufacturer shall not be liable for any loss or damage whatsoever arising from the use of information or any error contained in this manual, or through any misoperation or fault in hardware contained in the product.

It is recommended that all maintenance and service on the product should be carried out by the manufacturer or its authorised agents. The manufacturer cannot accept any liability whatsoever for any loss or damage caused by service, maintenance or repair by unauthorised personnel

SAFETY WARNINGS

The installation and servicing instructions in this manual are for use by qualified personnel only.

Read All Instructions. All safety and operating instructions must be read before operating the product. They also must be retained for future reference, as it contains a number of useful hints for determining the best combination of equipment settings for Yr particular application.

Heed All Warnings. All warnings on the product and those listed in the operating instructions must be adhered to.

Heat. This product must be situated away from any heat sources such as radiators or other products (including power amplifiers or transmitters) that produce heat.

Power Sources. This product must be operated from the type of power source indicated on the marking label and in the installation instructions. If you are not sure of the type of power supplied to your facility, consult your local power company. Make sure the AC main voltage corresponds to that indicated in the technical specifications. If a different voltage (ex. 110/115 VAC) is available, open the equipment closure and set the voltage switch on the main supply circuit, located behind the AC socket.

Power Cord Protection. Power supply cords must be routed so that they are not likely to be walked on or pinched by items placed upon or against them. Pay particular attention to the cords at AC wall plugs and convenience receptacles, and at the point where the cord plugs into the product.

Use only with a cart, stand, tripod, bracket, or table specified by the manufacturer, or sold with the apparatus. When a cart is used, use caution when moving the cart/apparatus combination to avoid injury from tip-over.

Lightning. For added protection for this product during a lightning storm, or when it is left unattended and unused for long periods of time, unplug it from the AC wall outlet and the audio connections. This will prevent damage to the product due to lightning and power line surges.

Installation. Configuration and installation should only be carried out by a competent installation engineer.

Cabling. Using high-quality wires, well protected. Make sure the cable integrity.



This symbol alerts you to the presence of dangerous voltage inside the closure – voltage which may be sufficient to constitute a risk of shock. Do not perform any servicing other than that contained in the operating instructions. Refer all servicing to qualified personnel.



The exclamation point within an equilateral triangle is intended to alert the user to the presence of important operating and maintenance (servicing) instructions in the literature accompanying the appliance.



Do not change the voltage setting or replace the mains fuse without first turning the unit off and unplugging the mains cord.



Make sure the AC main voltage corresponds to that indicated in the technical specifications.

THIS APPARATUS MUST BE EARTHED!



To avoid the risk of fire use the correct value fuse, as indicated on the label stuck on the right side of the unit.



This apparatus uses a single pole main switch and does therefore not separate the unit completely from the main power. To completely separate from main power (f.i. in the event of danger) unplug the power cord. As the main plug is disconnected from the device, the disconnect device shall remain readily operable.

CONSIGNES DE SÉCURITÉ IMPORTANTES

Lire ces consignes.

Conserver ces consignes.

Observer tous les avertissements.

Suivre toutes les consignes.

Ne pas utiliser cet appareil à proximité de l'eau.

Ne pas obstruer les ouvertures de ventilation. Installer en respectant les consignes du fabricant.

Ne pas installer à proximité d'une source de chaleur telle qu'un radiateur, une bouche de chaleur, un poêle ou d'autres appareils (dont les amplificateurs) produisant de la chaleur.

Ne pas annuler la sécurité de la fiche de terre, la troisième branche est destinée à la sécurité. Si la fiche fournie ne s'adapte pas à la prise électrique, demander à un électricien de remplacer la prise hors normes.

Protéger le cordon d'alimentation afin que personne ne marche dessus et que rien ne le pince, en particulier aux fiches, aux prises de courant et au point de sortie de l'appareil.

Utiliser uniquement les accessoires spécifiés par le fabricant.

Utiliser uniquement avec un chariot, un support ou une table spécifié par le fabricant ou vendu avec l'appareil. Si un chariot est utilisé, déplacer l'ensemble chariot–appareil avec précaution afin de ne pas le renverser, ce qui pourrait entraîner des blessures.

Débrancher l'appareil pendant les orages ou quand il ne sera pas utilisé pendant longtemps.

Confier toute réparation à du personnel qualifié. Des réparations sont nécessaires si l'appareil est endommagé d'une façon quelconque, par exemple: cordon ou prise d'alimentation endommagé, liquide renversé ou objet tombé à l'intérieur de l'appareil, exposition de l'appareil à la pluie ou à l'humidité, appareil qui ne marche pas normalement ou que l'on a fait tomber.

NE PAS exposer cet appareil aux égouttures et aux éclaboussures. Ne pas poser des objets contenant de l'eau, comme des vases, sur l'appareil.



Ce symbole indique la présence d'une tension dangereuse dans l'appareil constituant un risque de choc électrique.



Ce symbole indique que la documentation fournie avec l'appareil contient des instructions d'utilisation et d'entretien importantes.



Avant de modifier le commutateur de changement de tension ou remplacer le fusible il faut débrancher l'appareil de la prise électrique. Pendant son usage, l'appareil doit être branché à la prise de terre.



Utiliser le fusible principal AC avec la valeur qui est indiquée sur l'étiquette collée sur le coffret.



Assurez-vous que la tension principale AC correspond à celle indiquée dans les spécifications techniques.



L'interrupteur d'alimentation interrompt un pôle du réseau d'alimentation excepté le conducteur de terre de protection. En cas de danger, débrancher le cordon d'alimentation. Parce que la prise du réseau de alimentation est utilisée comme dispositif de déconnexion, ce dispositif doit demeurer aisément accessible.

ISTRUZIONI IMPORTANTI PER LA SICUREZZA

Leggere le presenti istruzioni.

Conservare queste istruzioni.

Osservare tutte le avvertenze.

Seguire scrupolosamente tutte le istruzioni.

Non usare questo apparecchio in prossimità di acqua.

Non ostruire alcuna apertura per il raffreddamento. Installare l'apparecchio seguendo le istruzioni.

Non installare l'apparecchio accanto a fonti di calore quali radiatori, aperture per l'afflusso di aria calda, forni o altri apparecchi (amplificatori inclusi) che generino calore.

Non rimuovere il terminale di connessione a terra sul cordone di alimentazione: esso ha lo scopo di tutelare l'incolumità dell'utilizzatore. Se la spina in dotazione non si adatta alla presa di corrente, rivolgersi ad un elettricista per far eseguire le modifiche necessarie.

Evitare di calpestare il cavo di alimentazione o di comprimerlo, specialmente in corrispondenza della spina e del punto di inserzione sull'apparato.

Utilizzare solo dispositivi di collegamento e gli accessori specificati dal produttore.

Utilizzare l'apparecchio solo con un carrello, un sostegno, una staffa o un tavolo di tipo specificato dal produttore o venduto insieme all'apparecchio. Se si utilizza un carrello, fare attenzione negli spostamenti per evitare infortuni causati da ribaltamenti del carrello stesso.

Scollegare l'apparecchio dalla presa di corrente durante i temporali o quando inutilizzato a lungo.

Per qualsiasi intervento, rivolgersi a personale di assistenza qualificato. È necessario intervenire sull'apparecchio ogniqualvolta si verificano danneggiamenti di qualsiasi natura. Ad esempio, la spina o il cavo di alimentazione sono danneggiati, è entrato liquido nell'apparecchio o sono caduti oggetti su di esso, l'apparecchio è stato esposto alla pioggia o all'umidità, non funziona normalmente o è caduto.

Non esporre a gocciolamenti o spruzzi. Non appoggiare sull'apparecchio oggetti pieni di liquidi, ad esempio vasi da fiori.



Questo simbolo indica la presenza di alta tensione all'interno dell'apparecchio, che comporta rischi di scossa elettrica.



Questo simbolo indica la presenza di istruzioni importanti per l'uso e la manutenzione nella documentazione in dotazione all'apparecchio.



Non sostituire il fusibile o cambiare la tensione di alimentazione senza aver prima scollegato il cordone di alimentazione. **L'APPARATO DEVE ESSERE CONNESSO A TERRA.**



Sostituire il fusibile generale con uno di identico valore, come indicato sulla etichetta applicata sul mobile dell'apparato



Assicurarsi che la tensione di rete corrisponda a quella per la quale è configurato l'apparecchio.



Questo apparato utilizza un interruttore di alimentazione di tipo unipolare e l'isolamento dalla rete elettrica non è pertanto completo. Per ottenere un isolamento totale (ad esempio in caso di pericolo), scollegare il cordone di alimentazione. Inoltre, poichè la spina di alimentazione è utilizzata come dispositivo di sezionamento, essa deve restare facilmente raggiungibile.

WICHTIGE SICHERHEITSHINWEISE

Diese Hinweise LESEN.

Diese Hinweise AUFHEBEN.

Alle Warnhinweise BEACHTEN.

Alle Anweisungen BEFOLGEN.

Dieses Gerät NICHT in der Nähe von Wasser verwenden.

KEINE Lüftungsöffnungen verdecken. Gemäß den Anweisungen des Herstellers einbauen.

Nicht in der Nähe von Wärmequellen, wie Heizkörpern, Raumheizungen, Herden oder anderen Geräten (einschließlich Verstärkern) installieren, die Wärme erzeugen.

Die Schutzfunktion des Schukosteckers NICHT umgehen. Bei Steckern für die USA gibt es polarisierte Stecker, bei denen ein Leiter breiter als der andere ist; US-Stecker mit Erdung verfügen über einen dritten Schutzleiter. Bei diesen Steckerausführungen dient der breitere Leiter bzw. der Schutzleiter Ihrer Sicherheit. Wenn der mitgelieferte Stecker nicht in die Steckdose passt, einen Elektriker mit dem Austauschen der veralteten Steckdose beauftragen.

VERHINDERN, dass das Netzkabel gequetscht oder darauf getreten wird, insbesondere im Bereich der Stecker, Netzsteckdosen und an der Austrittsstelle vom Gerät.

NUR das vom Hersteller angegebene Zubehör und entsprechende Zusatzgeräte verwenden.

NUR in Verbindung mit einem vom Hersteller angegebenen oder mit dem Gerät verkauften Transportwagen, Stand, Stativ, Träger oder Tisch verwenden. Wenn ein Transportwagen verwendet wird, beim Verschieben der Transportwagen-Geräte- Einheit vorsichtig vorgehen, um Verletzungen durch Umkippen.

Das Netzkabel dieses Geräts während Gewittern oder bei längeren Stillstandszeiten aus der Steckdose ABZIEHEN.

Alle Reparatur- und Wartungsarbeiten von qualifiziertem Kundendienstpersonal DURCHFÜHREN LASSEN. Kundendienst ist erforderlich, wenn das Gerät auf irgendeine Weise beschädigt wurde, z.B. wenn das Netzkabel oder der Netzstecker beschädigt wurden, wenn Flüssigkeiten in das Gerät verschüttet wurden oder Fremdkörper hineinfließen, wenn das Gerät Regen oder Feuchtigkeit ausgesetzt war, nicht normal funktioniert oder fallen gelassen wurde.

Dieses Gerät vor Tropf- und Spritzwasser SCHÜTZEN. KEINE mit Wasser gefüllten Gegenstände wie zum Beispiel Vasen auf das Gerät STELLEN.



Dieses Symbol zeigt an, dass gefährliche Spannungswerte, die ein Stromschlagrisiko darstellen, innerhalb dieses Geräts auftreten.



Dieses Symbol zeigt an, dass das diesem Gerät beiliegende Handbuch wichtige Betriebs- und Wartungsanweisungen enthält.



Vor Änderung der Netzspannung oder Sicherungswechsel Netzkabel trennen.
Das Gerät muss für den Betrieb geerdet werden.



Hauptsicherung nur mit einer gleichwertigen austauschen
(s. entsprechende Etikette).



Vor Einschalten Netzspannungseinstellung am Gerät überprüfen bzw. anpassen.



Inpoliger Netzschalter. In Notfälle oder für Wartungsarbeiten Netzkabel trennen. Der Netzstecker fungiert auch als Trennelement muss deshalb zugänglich bleiben.

INSTRUCCIONES IMPORTANTES DE SEGURIDAD

LEA estas instrucciones.

CONSERVE estas instrucciones.

PRESTE ATENCION a todas las advertencias.

SIGA todas las instrucciones.

NO utilice este aparato cerca del agua.

NO obstruya ninguna de las aberturas de ventilación. Instálese según lo indicado en las instrucciones del fabricante.

No instale el aparato cerca de fuentes de calor tales como radiadores, registros de calefacción, estufas u otros aparatos (incluyendo amplificadores) que produzcan calor.

NO anule la función de seguridad del enchufe polarizado o con clavija de puesta a tierra. Un enchufe polarizado tiene dos patas, una más ancha que la otra. Un enchufe con puesta a tierra tiene dos patas y una tercera clavija con puesta a tierra. La pata más ancha o la tercera clavija se proporciona para su seguridad. Si el toma corriente no es del tipo apropiado para el enchufe, consulte a un electricista para que sustituya el toma corriente de estilo anticuado.

PROTEJA el cable eléctrico para evitar que personas lo pisen o estrujen, particularmente en sus enchufes, en los toma corrientes y en el punto en el cual sale del aparato.

UTILICE únicamente los accesorios especificados por el fabricante.

UTILICESE únicamente con un carro, pedestal, escuadra o mesa del tipo especificado por el fabricante o vendido con el aparato. Si se usa un carro, el mismo debe moverse con sumo cuidado para evitar que se vuelque con el aparato.

DESENCHUFE el aparato durante las tormentas eléctricas, o si no va a ser utilizado por un lapso prolongado.

TODA reparación debe ser llevada a cabo por técnicos calificados. El aparato requiere reparación si ha sufrido cualquier tipo de daño, incluyendo los daños al cordón o enchufe eléctrico, si se derrama líquido sobre el aparato o si caen objetos en su interior, si ha sido expuesto a la lluvia o la humedad, si no funciona de modo normal, o si se ha caído.

NO esponga este aparato a chorros o salpicaduras de líquidos. **NO** coloque objetos llenos con líquido, tales como floreros, sobre el aparato .



Este símbolo indica que la unidad contiene niveles de voltaje peligrosos que representan un riesgo de choques eléctricos.



Este símbolo indica que la literatura que acompaña a esta unidad contiene instrucciones importantes de funcionamiento y mantenimiento.



Antes de cambiar la alimentación de voltaje o de cambiar el fusible, desconecte el cable de alimentación. Para reducir el riesgo de descargas eléctricas, esta unidad debe ser conectada a tierra.



Remplazé el fusible con lo mismo, que corresponde a lo indicado en el panel del equipo.



Antes de encender, controlar que la línea de alimentación de voltaje corresponda a la indicada.



El interruptor de alimentación es unipolar. En el caso de peligro, desconecte el cable de alimentación. Porque la clavija de conexión a red sirve por la desconexión de la unidad, la clavija debe ser ubicada en proximidad de la unidad.

UNPACKING AND INSPECTION

Your equipment was packed carefully at the factory in a container designed to protect the unit during shipment. Nevertheless, we recommend making a careful inspection of the shipping carton and the contents for any signs of physical damage.

Damage & Claims

If the damage is evident, do not discard the container or packing material. Contact your carrier immediately to file a claim for damages. Customarily, the carrier requires you, the consignee, to make all damage claims. It will be helpful to retain the shipping documents and the waybill number.

Save all packing materials! If You should ever have to ship the unit (e.g. for servicing), it is best to ship it in the original carton with its packing materials because both the carton and packing material have been carefully designed to protect the unit.

Under normal conditions, no user maintenance or calibration is required. Internal links and preset controls may be set to configure the unit during installation. Any service work required should be carried out by qualified service personnel only.

We are able to offer further product support through our worldwide network of approved dealers and service agents.

To help us provide the most efficient service please would you keep a record of the unit serial number and date and place of purchase to be quoted in any communication regarding this product.

The actual equipment Serial Number is indicated on the silver label stuck on the rear panel of the equipment closure.

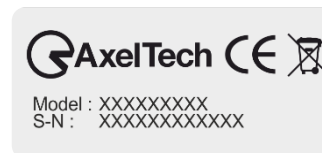

Tools And Equipment Needed

Only standard technician's tools are required to install this equipment.

FIRST INSTALLATION RECOMMENDATIONS

POWER SUPPLY CABLE

A power supply cable of approx. 2 mt lengths is supplied with the device, which has a moulded IEC plug attached – this is a legal requirement. The type of plug for the power supply depends on the country in which it is delivered.

If for any reason, you need to use this appliance with a different plug, you should use the following wiring guidelines in replacing the existing plug with the new one:

Earth	Green, or green and yellow
Neutral (N)	Blue
Live (L)	Brown

Supply cables should be laid in such a manner that one does not step or walk on them. They should not be squashed by any objects.

THIS EQUIPMENT MUST BE EARTHED.

The chassis is always connected to mains earth to ensure your safety: check your mains wiring and earthing before switching on.

PROTECTION AGAINST LIGHTNING



Should the device be put out of action due to being struck by lightning or excess voltage, disconnect it from the power supply without delay. Do not reconnect until the device has been checked. If in doubt contact the technical support service.

Make sure there is suitable lightning protection to protect the device. Alternatively, you should disconnect all connectors from the device during a storm or when the device is going to be unsupervised or not used for a longer period of time.

These measures will protect against damage by lightning or excess voltage.

VENTILATION

The equipment will operate as a free-standing unit without requiring any special cooling arrangement. However, slots and openings in the product are provided for ventilation. They ensure reliable operation of the product, keeping it from overheating. These openings must not be blocked nor covered during operation.

YOU MUST LEAVE AT A MINIMUM ONE RACK UNIT OF EMPTY SPACE ABOVE THE EQUIPMENT TO ENHANCE VENTILATION AND TO GET A LONGER EQUIPMENT LIFE.

DEVICE INSTALLATION

Best setup location

The device should be installed in a 19" rack. Avoid direct sunlight, close proximity to radiators and air conditioning, dust, water, and chemicals. Choose a rack location that permits a clear view of the indicators on the device and ensures a sufficient heat dissipation of the device.

Power supply

The device is designed for operation with 100 to 240 V AC, 50 Hz to 60 Hz. Check the corresponding device labelling for compatibility to the domestic line voltage and frequency before connecting the IEC power connector to the mains supply!



WARNING

Disconnect mains power plug before you open the housing. Repair of the equipment must only be carried out by authorized and qualified personnel.

Power Supply	Please make sure that the device and the contained fuse(s) (please see p. 20) are compatible with the domestic line voltage and frequency. If the device is compatible, connect the power supply cord fully to the IEC power connector at the rear side of the device and a mains power outlet. The LCD Screen will then turn on. NOTE: Falcon X6 without display.
Network configuration	For delivery, the device is configured with default settings for the first connection via the IP interface.
Connect to network	Connect a network patch cable to the “10/100-Base-T” connector on the rear side of the device and your existing IP network.
Web interface	The device can be fully operated with an internet browser via the integrated web interface. Use a computer that is connected to the same IP network that the FALCON device is connected to. Start an internet browser, Firefox/Mozilla >V2.0 Google Chrome both with Java Script activated and enter the configured IP address in the address bar of the browser. If the IP address has not been changed in step 2, please enter the default address in the address bar of the browser: 192.168.120.120 .
Ready!	These first steps are only intended for a quick first start and do not cover all device functions. Please read carefully the entire manual to be able to use all functions of the device.
Important note on the Username and password	The equipment comes out from Axel Technology with a standard username: admin and password: admin Each time a NEW user, with administration rights is created, the user admin disappears and it is replaced by the new one just created. If all users are deleted, the standard admin – admin comes out again

DEVICE GENERAL DESCRIPTION

FRONT PANEL

FALCON X5



FALCON X6



FALCON X7



FALCON D7



- Mechanical Steel, 1U - 19 " rack standard.
- USB Port - Type A.
- TFT Color Graphic Display 480x128 (not included in X6).
- Jog Shuttle (not included in X6).
- 40 Led Alarms.
- Headphone Jack 6.3mm Female Connector.

REAR PANEL

FALCON X5, X6, X7, D7

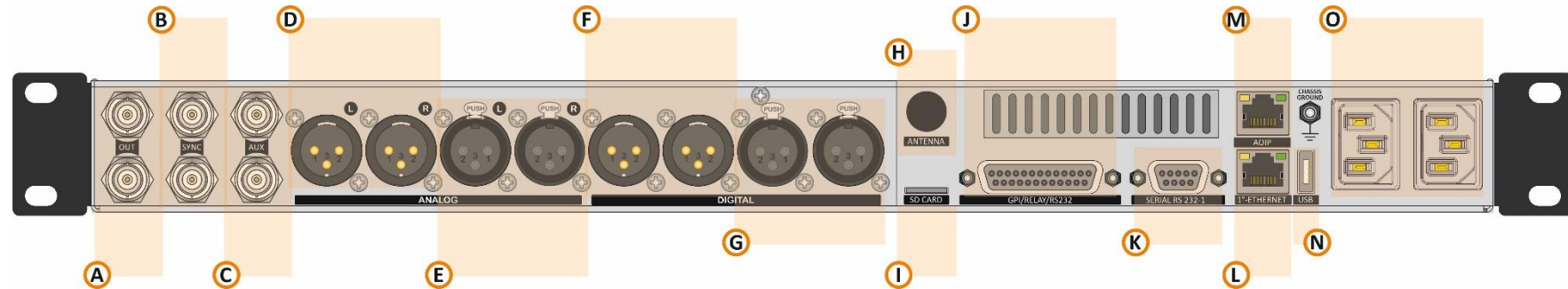

- A. 2 BNC output connectors: OUT-1 and OUT-2 (NOT IN FALCON D7).
- B. 2 BNC SYNC connections: IN and OUT (NOT IN FALCON D7).
- C. 2 BNC input connections: AUX-1 and AUX-2 (NOT IN FALCON D7).
- D. 2 XLR male: Analog stereo output.
- E. 2 XLR female: Analog stereo input.
- F. 2 Digital stereo output.
- G. 2 Digital stereo input.
- H. 1 BNC antenna connection input (OPTIONAL).
- I. Micro SD Card Slot.
- J. GPIO Port with 6 optocouplers and 4 relays on DB25 PIN Female connector.
- K. 1 serial port RS232 on DB9.
- L. Ethernet port over Rj45 connectors.
- M. Rj45 connectors: AOIP for DANTE network (OPTIONAL).
- N. USB port - Type A.
- O. Universal Power Supply 90Vac - 240Vac 50/60Hz.

The difference between models.

	X5	X5 PLUS	X6	X7	D7
Dante	Optional	Optional	Optional	Optional	Optional
Changeovers	Manual	Manual/Automatic	Manual/Automatic	Manual/Automatic	Manual/Automatic
Streaming	Optional	Optional	Optional	Optional	Optional
Backup/file player	Optional	Optional	Yes	Yes	Yes
RDS Encoder	Optional	Optional	Optional	Optional	No
Digital MPX output-3	Optional	Optional	Optional	Optional	No
Display	Yes	Yes	No	Yes	Yes
Tuner	Optional	Optional	Optional	Optional	No

1. FIRST DEVICE START

After important setting changes we suggest you always to reboot the device (For example: after a device upgrade, or changes on IP address).

1.1 STARTING YOUR FALCON - QUICK SETUP

Turn **ON** the **FALCON** device with the power switch, on the rear panel:

Connect the device to your **LAN** with an ETHERNET CABLE. Your device could be controlled by one of the following methods:

1. The device could be controlled by a web page on your browser. In the address field of your browser, type the default IP address: **192.168.120.120** You will see the Home Page:
2. We provided you with a small WIFI USB KEY. Connect it inside one of the USB ports of the device. **If you have more than a WIFI USB KEY connect once a time:**
 - a. Search for the following WIFI connection with your mobile phone, tablet or WIFI pc: **Config_AP**
 - b. Connect to **Config_Ap**
 - c. The password is **12345678**
 - d. The device could be controlled by a web page on one of your browsers. Open a browser inside your mobile phone, tablet or wifi pc and in the address field type whatever URL you want.

N.B.: do not type any *https* URLs.

DEVICE TEMPORARY IP ASSIGNMENT

<p>Take a standard USB key</p>	
<p>Inside the USB key create a new txt file - The file name must be exactly: NetworkTEMPConfig.txt</p>	
<p>Edit NetworkTEMPConfig.txt and write inside the temporary IP you want to set for your device. The syntax has to be: IP/24</p>	<p>Example: 192.168.0.14/24</p>
<p>Insert the USB key in the USB Port of the device front panel</p>	
<p>Open your browser and insert the IP in the URL address. If you plug out the IP you lose the temporary IP. (in this example we have set the 192.168.0.14 IP, but you can decide freely)</p>	

1.2 LOGIN

In the **Home Page**, you can find some parameters of your device. To see all parameters and to be able to change them as you want or as your station needs you have to login with a special Username and password.

Click **LOGIN** at top-right.

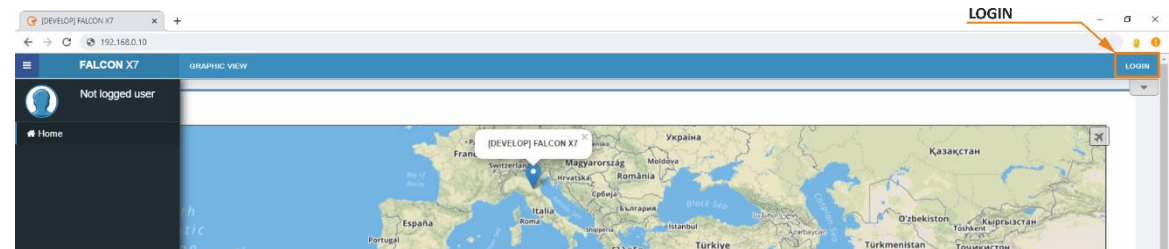

The equipment comes out from Axel Technology with a standard username – the default admin:

Username: **admin** (case sensitive)
 password: **admin** (case sensitive)

NB: Each time a NEW user, with administration rights is created, the user **admin** disappears and it is replaced by the new one just created. If all users are deleted, the default admin comes out again, in order to create and enter the device settings.

You will see the Login mask as shown in this picture:

In the first field type for your **Username**, and in the second one type for the **Password**. Then click on **Login**.

If you see the following message, you typed a wrong **Username** or a wrong **Password**. Type them again and retry.

When you logged you will be able to see the **MENU** list at the left side of the web page. As this figure shows, you can see how many persons logged in this device at this moment. Also appear the level of this account like (guest, user, admin, full administrator....).

Note: This information is only available for logged in users.

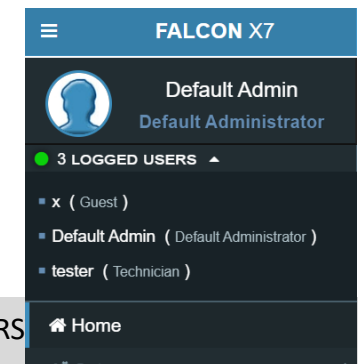
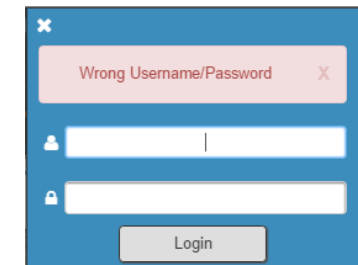
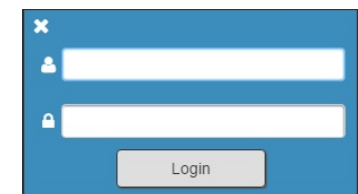

From the **Administration Page**, you can manage all the users and the user classes. You can create or delete users choosing between the available user classes:

- Full Administrator**
- User Administrator**
- Device Administrator**
- Technician**
- Broadcaster**
- Guest**

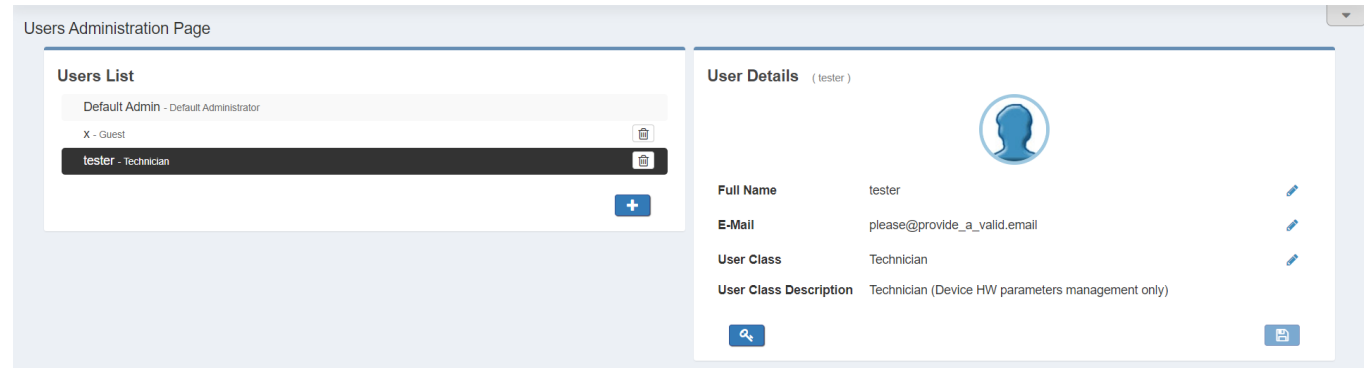

Full Administrator

The Full Administrator manages all user profiles, accesses all pages (except the calibration).

Default Administrator (Default User): The default administrator is the default user of the device, it is under the Full Administrator category, but it has fixed access credentials (user: admin – pwd: admin). This **DEFAULT ADMIN** is available only when the system has no other Full Administrators.

User Administrator

This user can only manage users. He can create or destroy users or modify their characteristics.

Device Administrator

This user can access to all target's parameter, but he can't manage users.

Technician

This user can manage functional target parameters only (e.g. port configurations or signal levels).

Broadcaster

This user can manage **content** target parameters only (e.g. Radiotext messages).

Guest/Reader

Guest accesses anywhere without being able to edit any parameter.

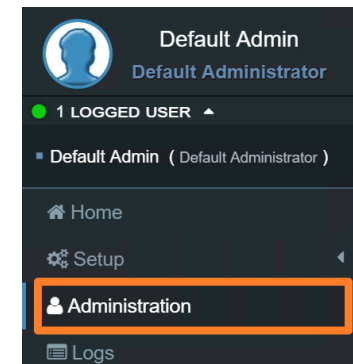

Note: Non-administrator account may can not able to see some parts of MENU, like (administration).

2. QUICK SETUP

From this quick setup, you can set the basic **FALCON** parameters to make your radio come to life in a few simple steps.

To begin the quick setup procedure, go to [Home > Save/Load Config > Easy Config > Quick RDS Setup](#).

That is 6 different Quick Setup mode to set your **FALCON** as your project needed:

1. Single audio source with MPX & RDS generation.
2. Double audio sources with audio changeover, MPX & RDS generation.
3. RDS generator configuration.
4. MPX rebroadcast with RDS regeneration and UECP filter on incoming RDS.
5. Double audio sources with audio changeover and MPX changeover with MPX backup source.
6. Double audio sources with audio changeover and MPX changeover with MPX main source.

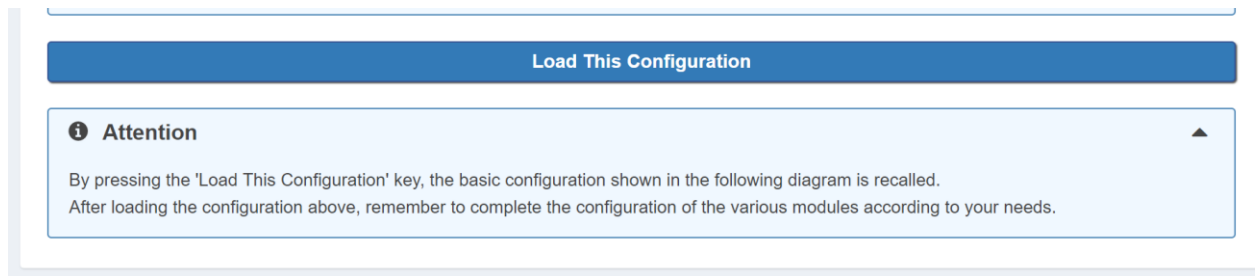

Go down on the same page, read the instructions until the end of the page and choose the mode of setting that you need. You can set all the most important **RDS** Parameters. **In this way, you can be immediately ONAIR**. We suggest you change device Network Ip Address and to create the Users that you need.

Data set

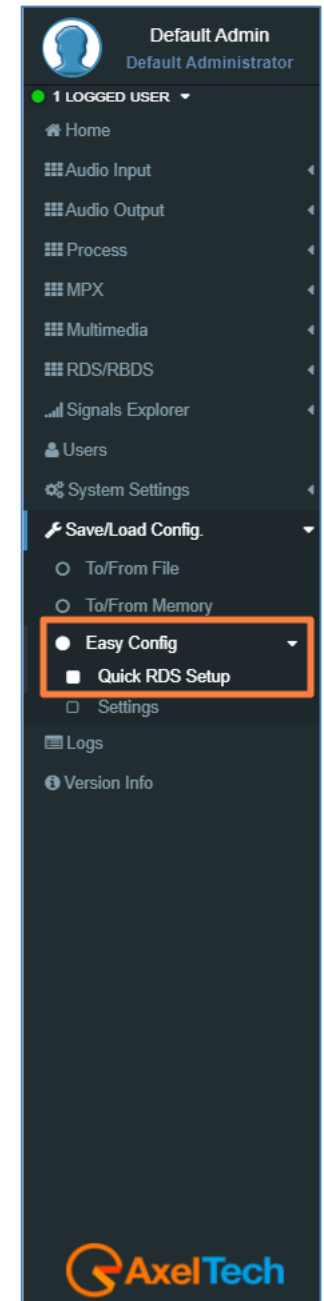

Data set it's the whole RDS setup that you can create. You can find available from **DATASET1** up to **DATASET8**. This gives you more ability to change all parameters needed in one click. [RDS/RBDS -> Basic Settings -> Rds Settings -> Active Dataset Selection](#).

3. HOME PAGE/GRAPHIC VIEW

Once you are logged, you will see the home page as shown in the following picture. The left-tree menu could be different for different user classes:

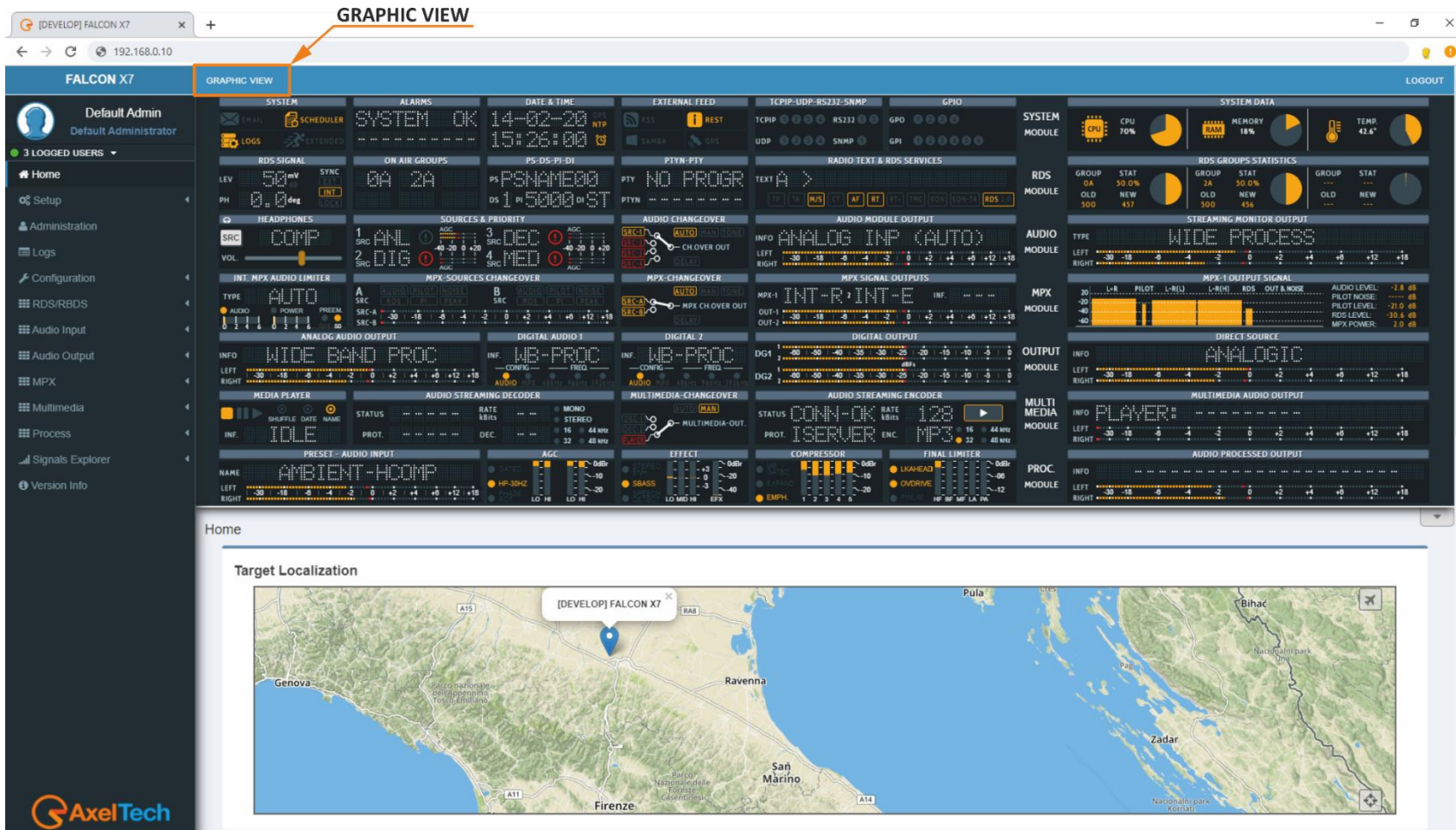

The graphical user interface (**GRAPHIC VIEW**) has been developed to be in a simple and easy way to work for the user in the process of tracking the signal and noting alerts in the event of an alarm. It also aims to facilitate access to the paragraphs to be modified.



1. **AUDIO SELECTOR:** from this zone can manage inputs source and switching mode. The two-level meter is indicating the level of the audio input source.
2. **PROCESSING:**
3. **AUDIO OUTPUTS:**
4. **MPX:**
5. **MONITOR:**
6. **SYSTEM INFORMATION:**

Breve hint of some elements



From this icon can enter to the settings in order to access more detailed information, or to make adjustments.

NOTE: This feature is available for a certain category of users depending on the user classification.



This icon provides access to a wider graphical interface, where all features are displayed in a linear format, allowing the user to track the signal path and the points it passes through to do the necessary changes.

NOTE: This feature is available for a certain category of users depending on the user classification.



This icon indicates the presence of the signal from the source and that the signal condition is stable.



This sign appears in the event that the signal is lost from the source or if there is a malfunction in the settings.





This element provides the names of some of the icons shown in the graphical interface. In addition to the date, time, system status and physical state of the device. Also, some alerts and properties that have been activated on this unit are shown.

3.1 AUDIO SELECTOR

From here, the four main audio sources can be identified, in addition to the sound generator, which is measuring the sound quality at a specific frequency and a certain situation, where you can specify whether stereo (L+R, L-R, only L, only R). In addition to the ability to determine the level.

3.1.1 SOURCE SETTING:

By clicking on the setting icon (gear) will automatically appear the audio properties for that source (It will appear as a drop-down menu at the bottom of the **INFO** bar), where you can control the **mode**, **sensitivity** level, **AGC** Automatic Gain Control, **verification** and **events**.

It is worth noting that when modifying the properties of the first source, for example, and the first source has been designated as a digital source, then these modifications are dependent on the digital source itself and have no relation to the first source or the second or others because the **MODE** arrangement is only to determine the priority.

For example, the modifications that we make to the properties of the analog audio source can be reached also through the following steps: **MENU > AUDIO INPUT > SOURCES > ANALOG**
The LED METER here indicates the audio level of the source that was set automatically or manually to be **ON AIR** as indicated here in the green rectangle below the first source.

3.1.2 AUDIO SELECTOR MODE:

When you need to change the source selection mechanism (the changeover) between **automatic*** (According to priority) and **manual** (forcing a specific source to be the chosen source), or change the priority, you can simply click on the settings icon (gear) next to the **MODE** or via the following steps: **MENU > Audio Input > Audio Selector**

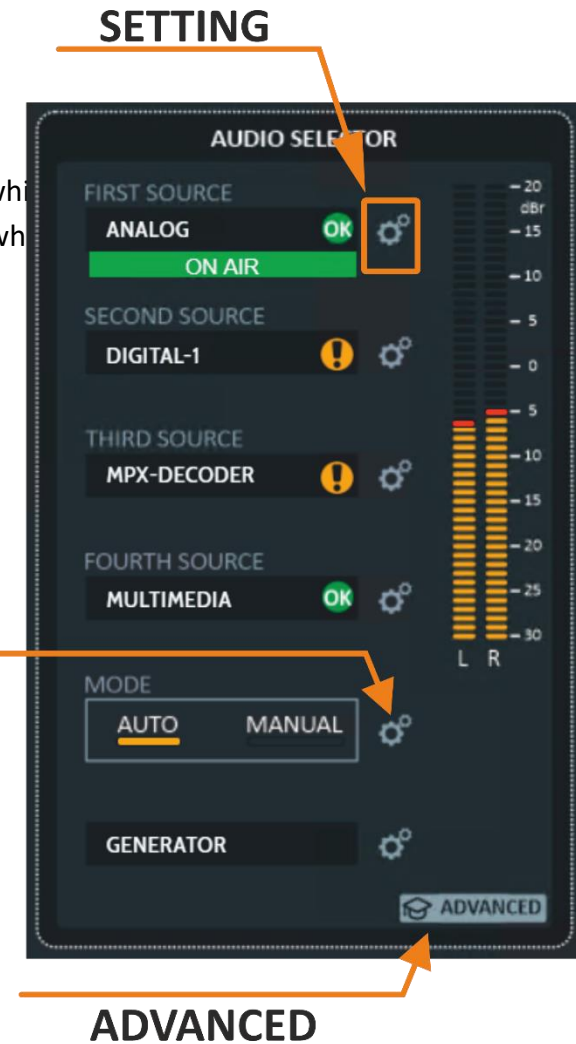

3.1.3 ADVANCED AUDIO SELECTOR

Once you click on the **ADVANCED** icon of the audio selector, you will automatically switch to a more detailed graphics view, which provides more information about the sound sources and also allows tracking of audio tracks. also, you can manage the inputs audio routing which controlled by 5 different audio changeover.

* not in FALCON X5

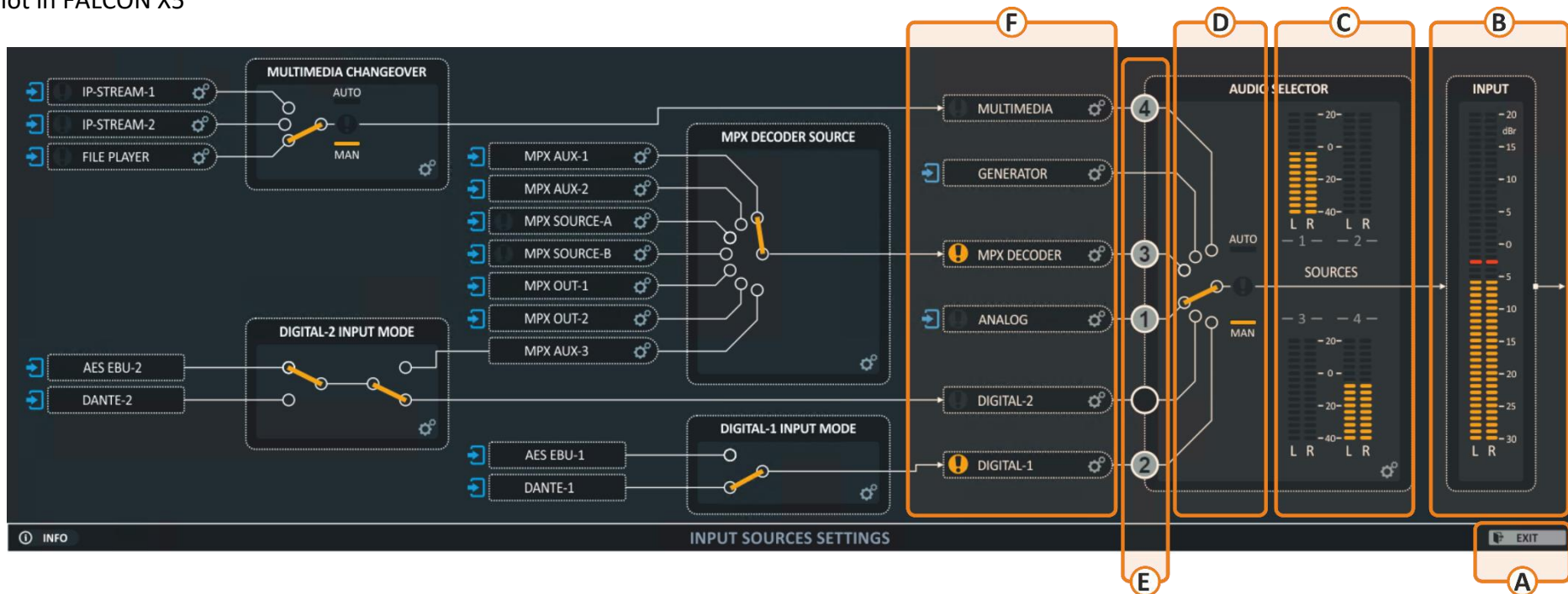

Here we show the audio tracks in the all-available inputs in this unit in more detail. It can also track the audio tracks very easily and monitoring all the inputs at the same time to see if there is any defect in one of them through the appearance of the **ALARM** icon.

It also allows easy control of inputs and quick access to properties of all inputs.

- A- From here can go back the main GRAPHIC VIEW.
- B- This LED bare is show up the audio input selected to be ON AIR.
- C- Here can monitoring the audio level of the four audio inputs selected to be main audio inputs.
- D- **Main audio changeover** who can control the main audio input by **automatic*** or **manually** switching.
- E- These numbers indicate the order of priority in using those available and stable sources by the main audio changeover.

Where the arrangement is ascending. Number one is the highest priority. You can change the preferred sources and re-prioritize as desired by clicking on the Settings icon (gear) at the bottom of this block or via the following steps: **MENU > Audio Input > Audio Selector**

- F- Here can see and manage the audio sources associated with the audio selector. By clicking on the setting icon (gear) will automatically appear the audio properties for that source (It will appear as a drop down menu at the bottom of the **INFO** bar), where you can control the **mode**, **sensitivity** level, **AGC** Automatic Gain Control, **verification** and **events**.

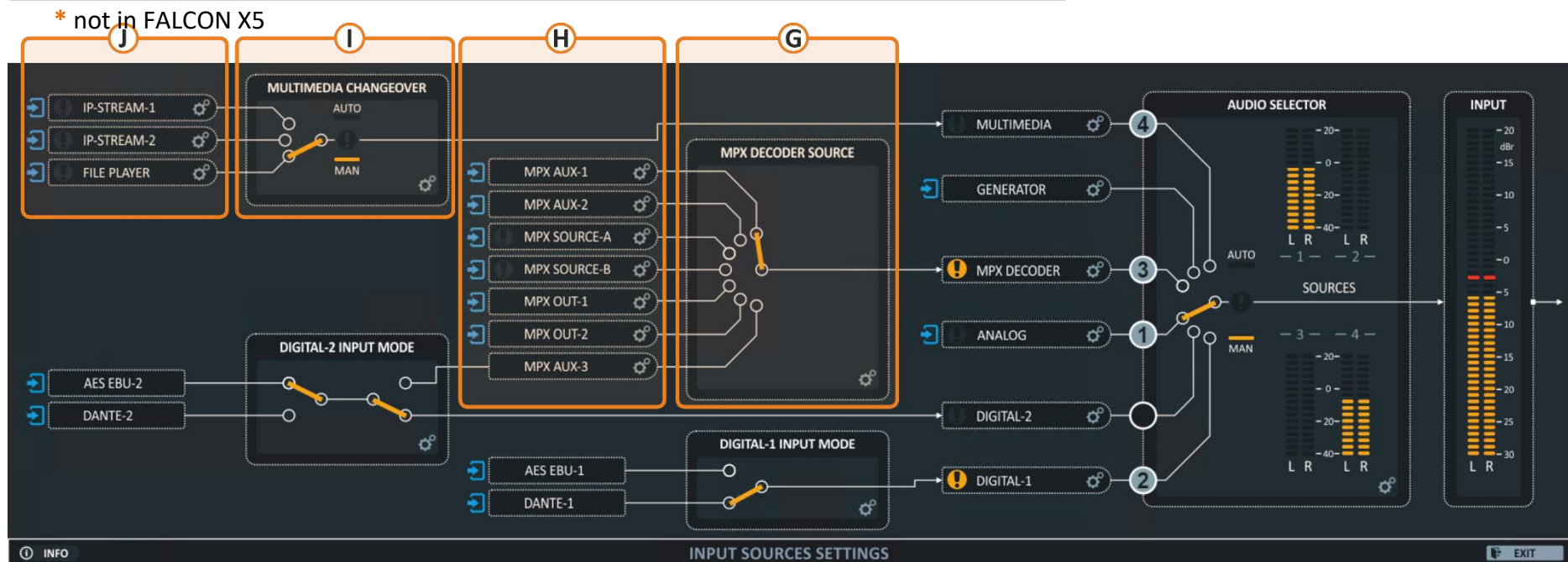

- G- **MPX DECODER**, it can be select between external or internal **MPX** sources.
- H- Here we have six **analog MPX** sources, and the seventh is a **digital MPX** signal from the second digital input, which in turn may be either AES/EBU or Dante (AOIP Audio Over Internet Protocol). May include both external and internal sources, which can be combined with **RDS*** from an external or internal Encoder.
- I- The multimedia changeover can switch the **MULTIMEDIA source*** between three different sources **Automatically**** or **manually** to feed the **MULTIMEDIA** source, which used to get an audio streaming from anywhere or playing audio files by the **media file player**.

J- In this part can find **two streaming** sources (AOIP Audio Over Internet Protocol) and **media file player**. Can manage them by clicking on the setting icon (gear), the streaming allows getting an audio flow from anywhere over the most common **AOIP** Audio Over Internet Protocols like (**RTP**, **UTP**, and **Iccast**). As for the **media file player**, it helps to create a playlist of audio files from the **micro-SD card** memory and insert this memory in the **SD card slot** at the rear of this device. It can also use the **FTP protocol** to manage those files, and this source can be used as a **backup source** in an emergency, maintenance cases, also can be set to play automatically when a source is lost.

* Optional.

** Not in FALCON X5

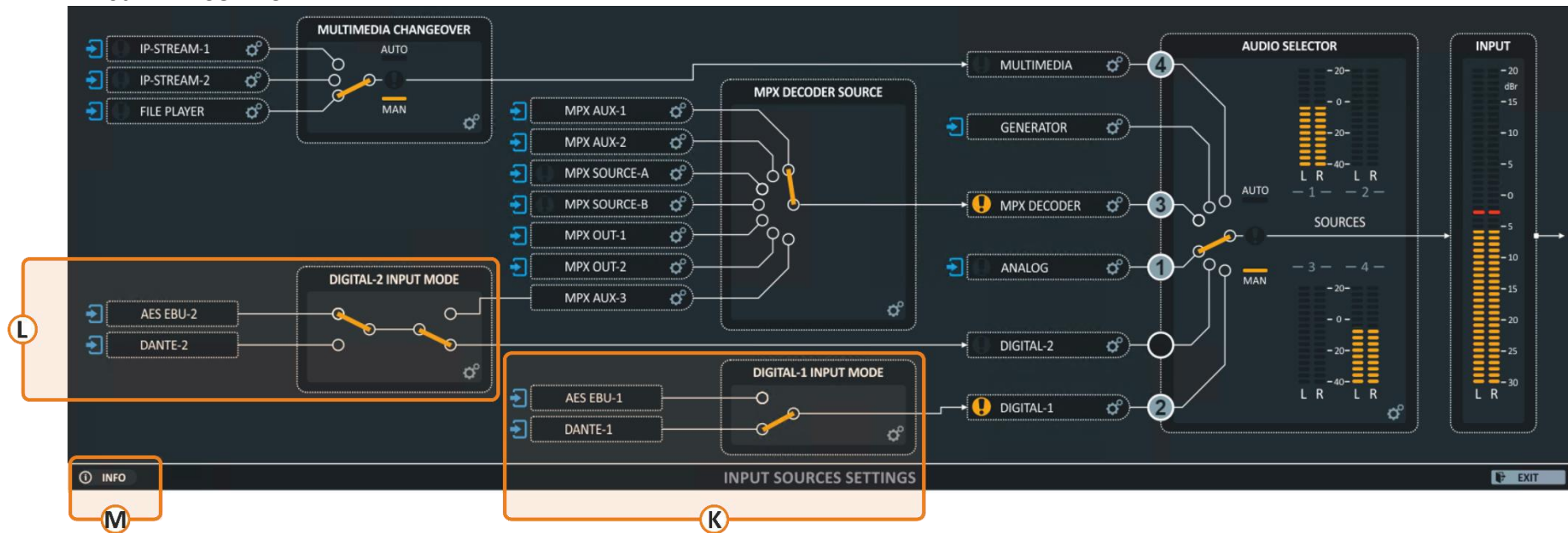

K- Here can switch the **DIGITAL-1** between **AES/EBU-1** and **DANTE-1***.

L- From here it can set the **AES/EBU-2** or **DANTE*** as a **DIGITAL-2**, or can send the **AES/EBU-2** to the **MPX AUX-3** to use it like a **DIGITAL MPX** source.

M- By clicking on this icon, it will show up a list of the symbols used in the **GRAPHIC VIEW** shown in the next figure.

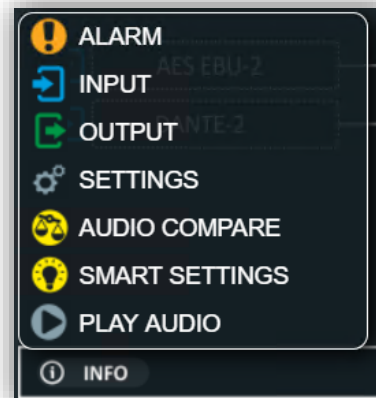

* Optional.

3.2 PROCESSING

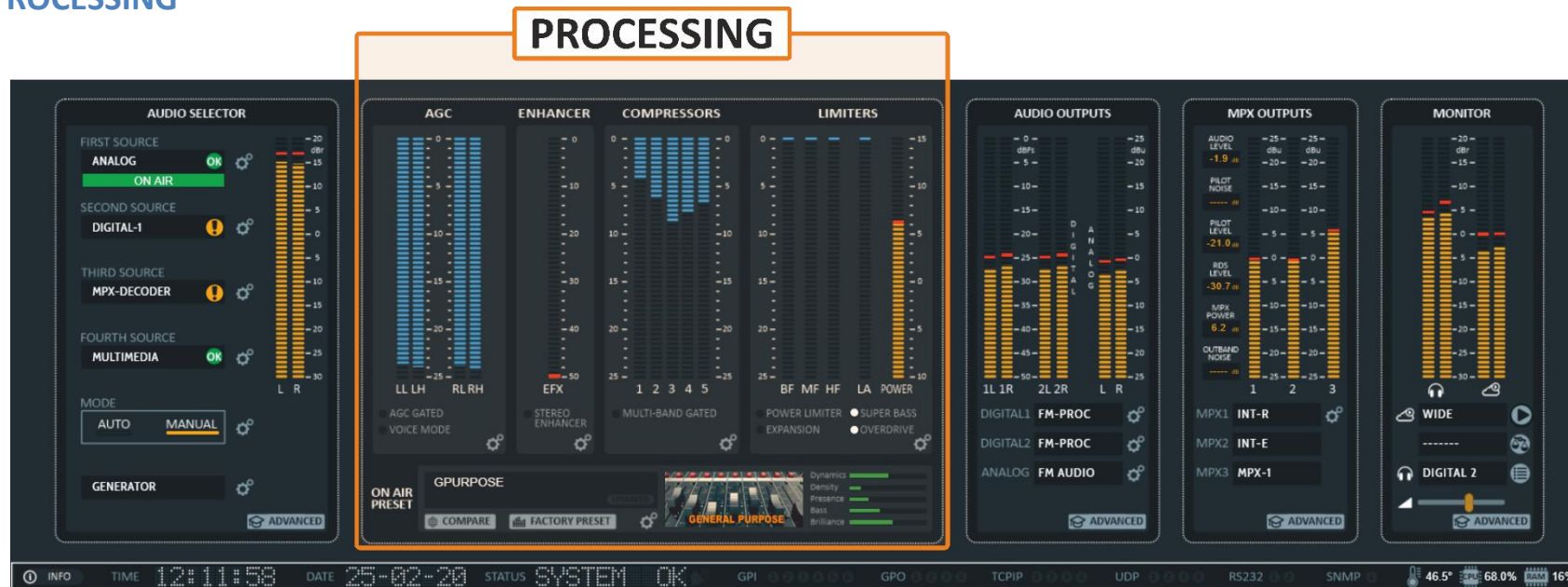

Audio processing functions are all fully customizable: **5 bands** compression control, adjustable drive and **threshold**, dual bands **AGC**, **3 bands equalization** (Low, Mid and High frequency) and brightness control. The mono sounds phase control allows to give to the human voice a more natural and pleasant sound shape. The final limiter enhances the sound presence. 40 memories allow to recall factory pre-sets or save new one to be restored according to customer needs.

It possible to manage each one of them by clicking on the setting icon (double-gear ⚙️). It is also can rich the setting page by go to [MENU > Process > \(AGC, Enhancer, Compressors, Limiters, Factory Presets & User Presets\)](#)

1. **AGC:** double band automatic gain control filter attempts to make the audio level constant.
2. **ENHANCER:** The Stereo Enhancer is designed to improve the width of stereo mixes and individual sounds.
3. **COMPRESSORS:** A dynamics effect that alters the volume level of an audio signal, making soft passages louder.
4. **LIMITERS:** A compressor whose output level remains constant regardless of its input level.
5. **PRESET:** There are two kinds of presets (**Factory Presets** and **User Presets**). There are ten basic and carefully selected presets included, such as (GENERAL-PURPOSE, AMBIENT, ROCK, HARDROCK, COUNTRY, ...etc.), which can be add more in future updates, and it can be modified according to the needs of the user and keeping these adjustments in the list of user settings.

3.3 AUDIO OUTPUTS



There are two digital AES/EBU outputs and one analog output. All digital and analog outputs can be independently switched to emit **WIDE BAND PROCESS, FM AUDIO PROCESS** and **FM DELAYED PROCESSED** signal.

DIGITAL1: the left/right digital outputs are on one XLR-type male plug on the rear panel.

DIGITAL2: the left/right digital outputs are on one XLR-type male plug on the rear panel.

ANALOG: the left/right digital outputs are on two XLR-type male plug on the rear panel.

Both analog and digital outputs are active continuously.

According to **AES/EBU** standard, each digital output line carries left and right stereo channels. The connection is 110 Ohm balanced. The **AES/EBU** standard specify a maximum cable length of 100 meters. While almost any balanced and shielded cable will operate for relatively short periods (5 meters or less), longer rounds require the use of a 110 Ohm balanced cable such as Belden 1800B.

From the mitters monitoring the audio level on outputs both digital and analog. By clicking on the setting icon (double-gear ⚙️) of each output can change the parameters of it like (Source, Rate, and Level).

When you click on **ADVANCED** It will automatically switch to a graphical interface that allows you to track the signal to the audio outputs in an expanded and more detailed way as shown in next figure.

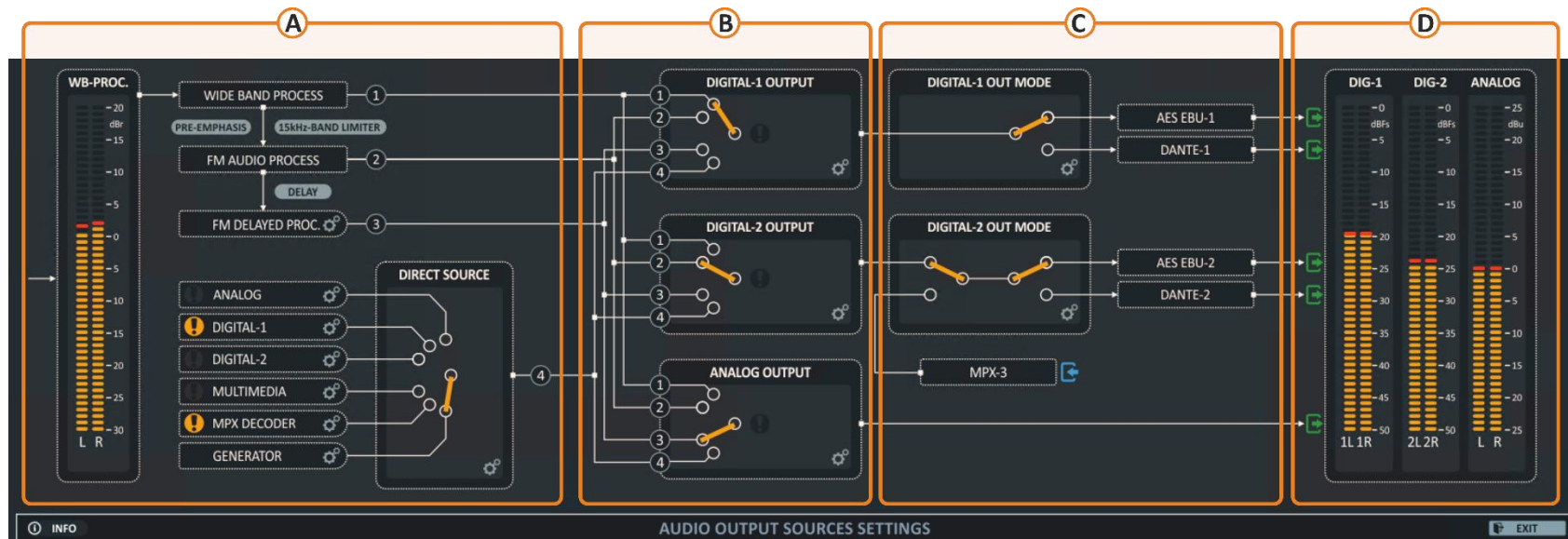

From this ADVANCED graphical view, it can be tracking the audio outputs path.

- A. In this corner it contains the **four main sources**, where **the first three sources** branch off from the same processed audio signal.
1. **WIDE BAND PROCESSED**: Wideband audio, also known as wideband voice or **HD voice**. Wideband audio relaxes the bandwidth limitation and transmits in the audio frequency range of **50 Hz** to up to **20 kHz** for **DAB** and **HD radios**.
 2. **FM AUDIO PROCESSED**: PRE-emphasized, **20 Hz – 15 kHz** bandwidth.
 3. **FM DELAYED PROCESSED**: This kind of signal serves to synchronize the digital broadcast with the analog broadcast signal.
 4. **DIRECT SOURCE**: by this source it can send the input audio signals, Multimedia, MPX decoder or Generator directly to the outputs.
- B. Here we find in this part the three main outputs (**DIGITAL-1, DIGITAL-2, ANALOG**) except the **streaming*** that are managed from the ADVANCED VIEW of MONITOR section. Each of these outputs contains a manual changeover that allows you to choose the required source from four sources which are (WIDE BAND PROCESSED, FM AUDIO PROCESSED, FM DELAYED PROCESSED and DIRECT SOURCE). Also, once you click on the double gear ⚙️, you will be moved to the section where there is also an available **Level** adjustment and **Rate****.
- C. **DIGITAL OUTPUT MODE**: From here, we can choose if we want to send the **DIGITAL** signal to **AES EBU** or **DANTE***.
- D. **LEVEL METER**: here can monitor the final audio signal level.

* Optional.

** Digital outputs only.

3.4 MPX OUTPUTS



MPX OUTPUTS: the MPX signal is including a **mono audio** (LL+RL), **stereo audio** (LH-RH), 19 kHz stereo **pilot tone** and **RDS** data (Radio Data System), which can be sent to the FM transmitter using a good quality.

In addition, other services such as Subsidiary Communications Authorization (**SCA**) channels may be adding to the MPX signal from external source like by **AUX1** and **AUX2** which are modulated onto higher subcarriers, **67 kHz** and **92 kHz**.

Here we have **three MPX** outputs, one of them is a digital MPX signal formatted for interconnection using AES/EBU codec at **192 kHz** sample rate. MPX over AES is carried on **AES EBU-2** or **DANTE-2** output channels (see **ADVANCED OUTPUTS** / part **G**).

In most applications only RDS data is transmitted in addition to the audio program which is carried at 57kHz. But there are some applications that require a wider spectrum for other services such as Subsidiary Communications Authorization (SCA) channels, **SCA-1** and **SCA-2** may be generated which are modulated onto higher subcarriers, **67 kHz** and **92 kHz**. however, Our **DIGITAL MPX** signal is **96kHz** spectrum.

AXEL codecs of **DIGITAL MPX Over Internet Protocol** provide a very low latency transmission between 5 and 35ms.

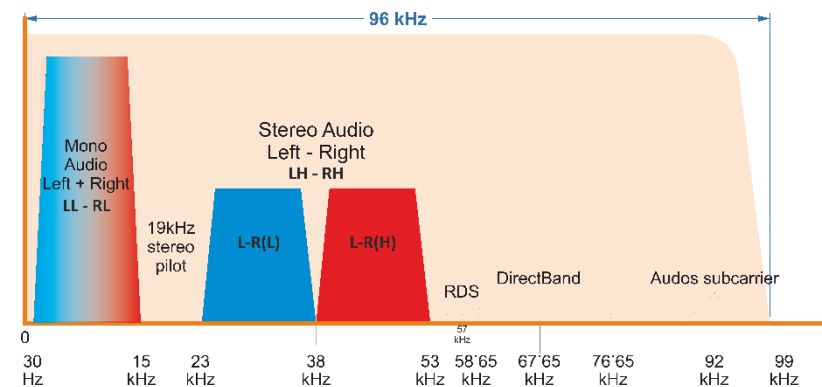

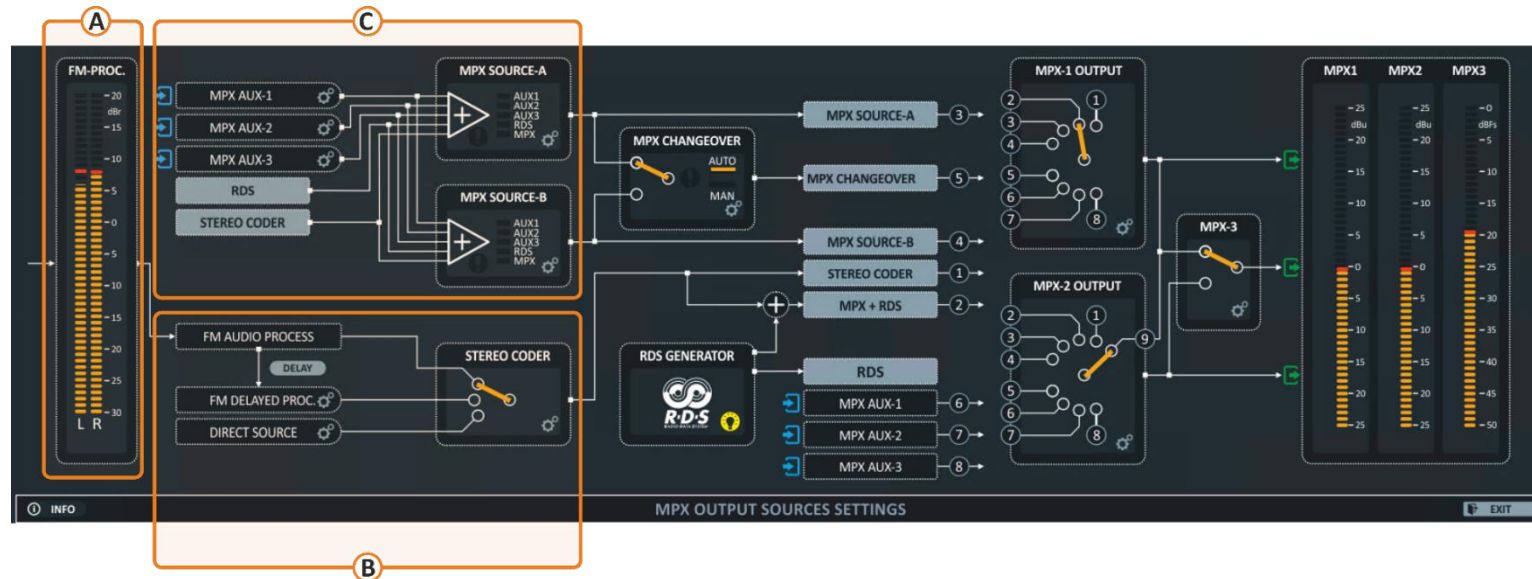

- A. **AUDIO METER** of the main FM processed audio signal. The scale is from **-30 to 20 dB** to get a perfect measurement of the Left and right signal.
- B. **STEREO CODER CHANGEOVER:** Before associate the processed **FM** audio signal pr the **DIRECT SOURCE** with **MPX** and **RDS** to be published in MPX output, here can select manual which of these sources will used in **STEREO CODER** and **MPX+RDS**.
FM DELAYED PROCESSED: this feature used to synchronize the digital broadcasting as **DAB, HD radios** ore **visual radios** the analog broadcast by delayed the audio. By clicking on the double-gear ⚙ will appear the FM Process page that allows to change the **PreEmphasis, Output DeEmphasis** and **Delay** time.
DIRECT SOURCE: from here can select one of the inputs (Analog, Digital-1, Digital-2, Multimedia, External MPX and Tone Generator) to go directly to the Stereo coder and MPX+RDS.
STEREO CODER: By pressing on the double-gear ⚙, the settings will be shown where can be control the **INTERNAL MPX ENCODER** like Internal MPX generator Source, MPX Mode (Stereo, Mono, L+R, L-R, Pilot only), Pilot Level/phase.
- C. Here we have two main sources (**MPX SOURCE-A, MPX SOURCE-B**) that practically act as a mixer that allows mixing the internal MPX signal with the MPX signal that can be obtained from external sources (**AUX-1, AUX-2, AUX-3**) and as such the **RDS** data.
 It is easy to know which signals are associated or mixed together by noticing the orange sign next to each source. That is also able to control the **References** of A and B sources by clicking on the double gear of AUX sources. and control the **MPX Sensitivity** of each AUX source.

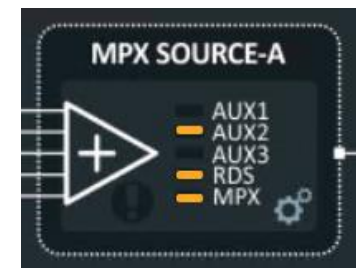

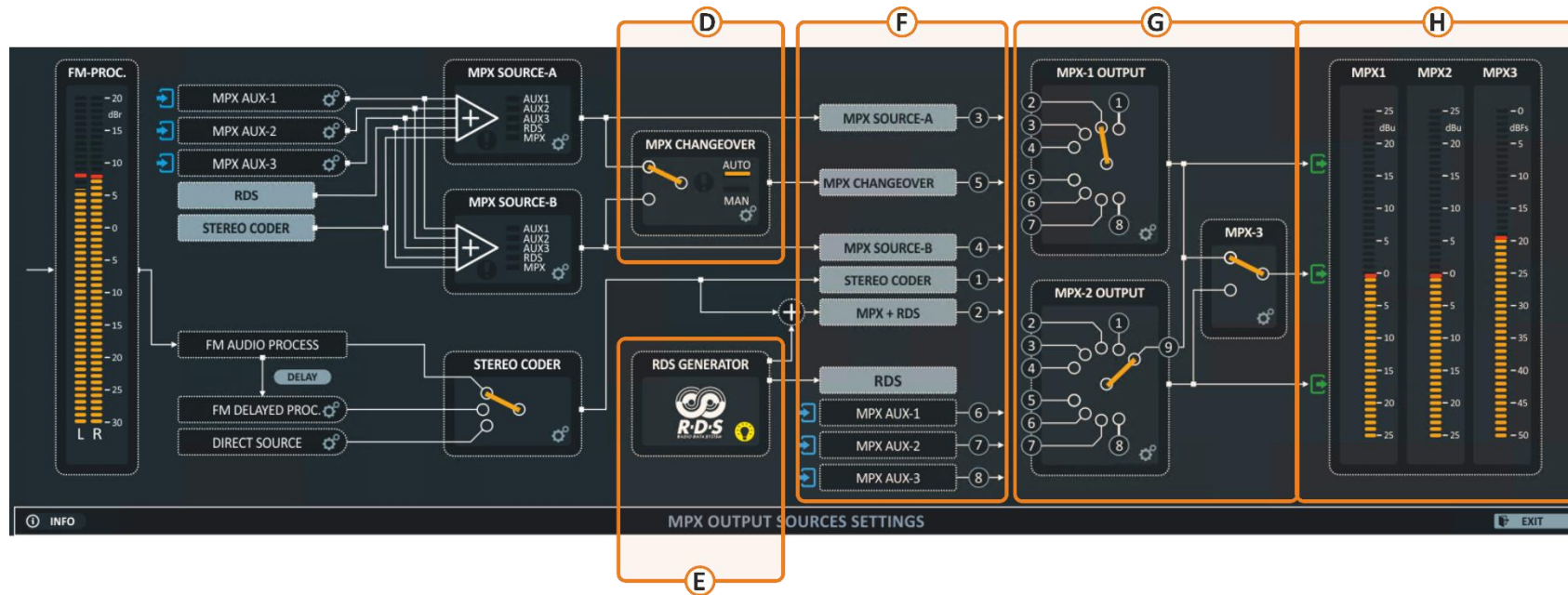

- D. **MPX CHANGEOVER:** this is an automatic* and manually changeover to switch between **MPX A** and **B** source in case that one of them is missing or any other reasons. This option provides you with a more flexible third source available for the OUTPUTS. Instead of choosing a **source A** or **source B** available list of sources that can be sent via any of the MPX OUTPUTS, you can simply choose the changeover to prevent a break in the transmission if the signal is lost.
- E. **RDS GENERATOR:** from the yellow icon an access to basic **RDS** settings and adjust the RDS Signal level, radio identity, Radio Text and all other properties.
- F. List of the internal, external and mixed MPX signal delivered to the MAIN THREE OUTPUTS.
- G. Two of the analog sources, and the third is related to one of them, as it quotes one of the two signals via a manual changeover and rephrases it to be output in digital format using AES/EBU at 192 kHz sample rate may be either AES/EBU or Dante* (AOIP Audio Over Internet Protocol).
- H. **Bar graph meters**

* not in X5 model.

3.5 LOGGED IN USER – HOME PAGE/COMPACT VIEW

Once you are logged, you will see the home page as shown in the following picture. The left-tree menu could be different for different user classes:

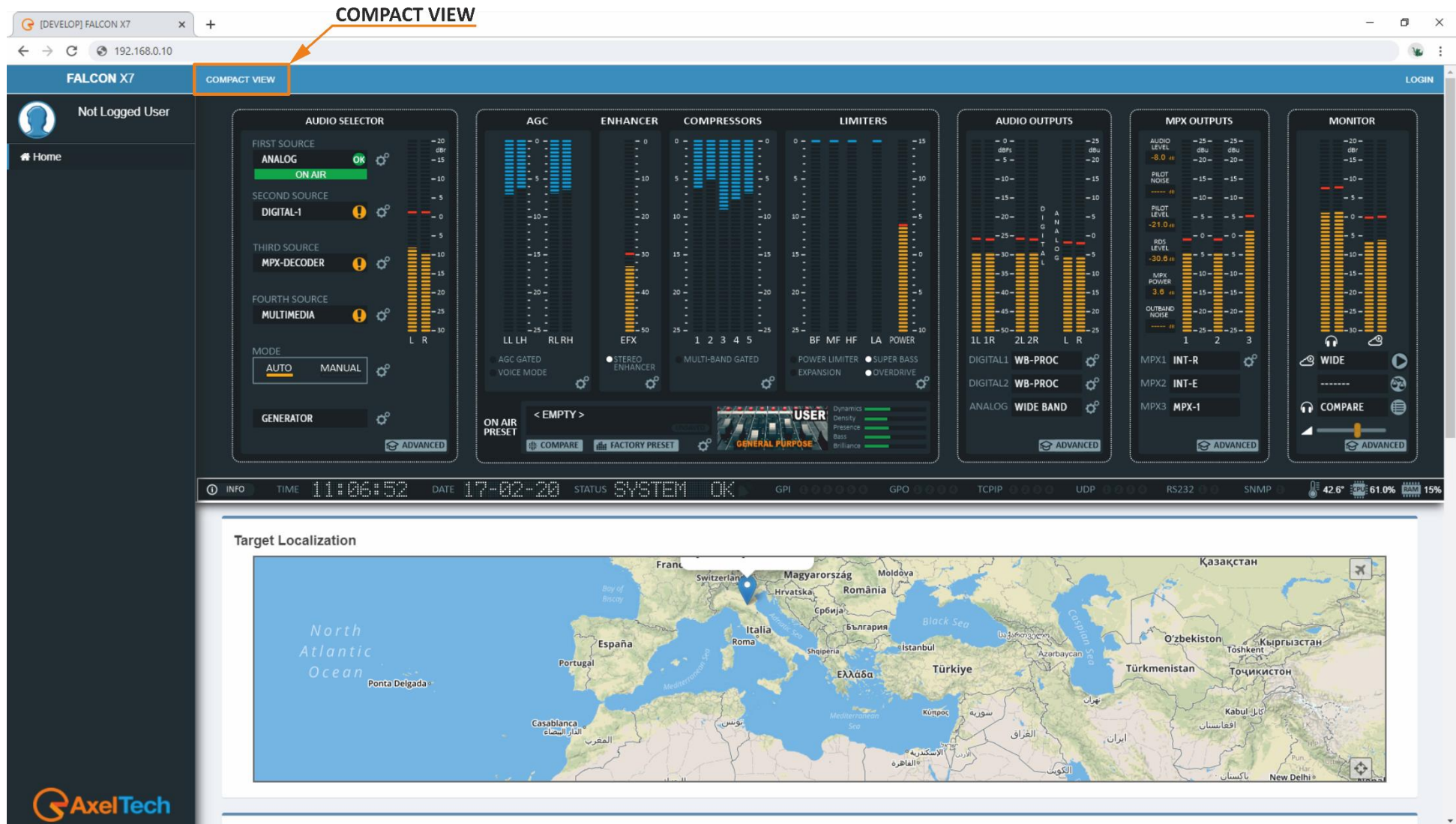

4. SUMMARY MASK

At the top of the page you can see a fast summary mask with all the current parameters and warnings as shown in the following picture:

1. **SYSTEM MODULE:** you can read from this part the most important system of data management.
2. **RDS MODULE:** from this part, you can read the most important RDS parameters and status.
3. **AUDIO MODULE:** from this part, you can read the most important audio sources and output settings.
4. **MPX MODULE:** from this part, you can read the most important MPX sources settings.
5. **OUTPUT MODULE:** here we can monitor the digital or analogue audio outputs.
6. **MULTIMEDIA MODULE:** from this part, you can read the multimedia sources.
7. **PROCESSOR MODULE:** here you can see monitor your processor setting and In/Out audio level.
8. From this **slide banner**, you can select which sections of the mask you want to view or hide.

The screenshot displays the Falcon Summary Mask interface, which is divided into several sections. The interface is dark-themed with orange accents. At the top, there are several status indicators and system data. Below this, the interface is organized into rows of modules, each with its own set of parameters and controls. The modules are: SYSTEM, RDS SIGNAL, HEADPHONES, INT. MPX AUDIO LIMITER, ANALOG AUDIO OUTPUT, MEDIA PLAYER, PRESET - AUDIO INPUT, SYSTEM MODULE, RDS MODULE, AUDIO MODULE, MPX MODULE, OUTPUT MODULE, MULTIMEDIA MODULE, and PROC. MODULE. A slide banner at the bottom right allows users to select which sections they want to view or hide. The interface also includes a map for target localization.

To show or hide the MODULE's canvas, Open the slide bar button under the SUMMARY MASK as shown in the next figure.

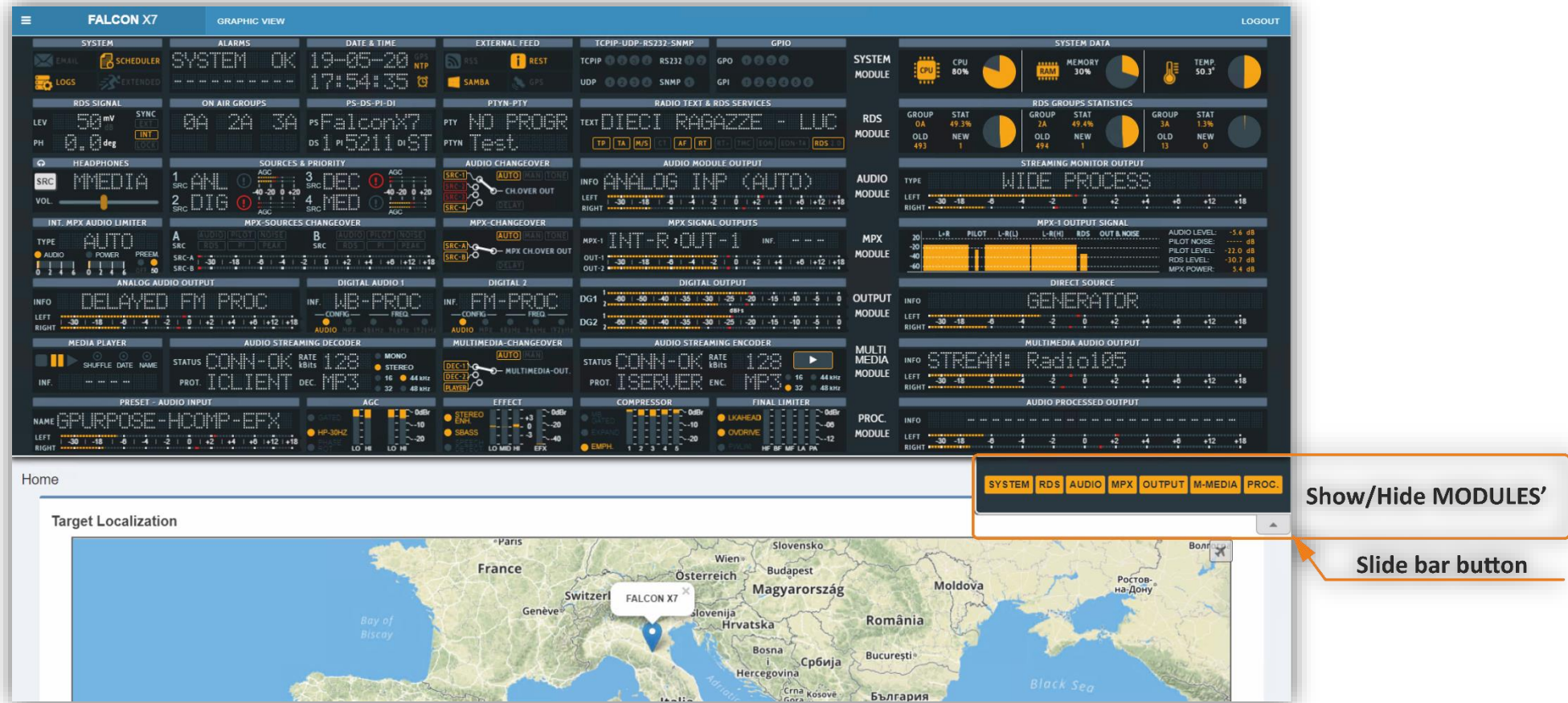

In this page can find all information about the device like name, location, IP, Firmware version and serial number. The Target Localization module provides detection of a specified target (device location) it is used in case that you have many RDS service points. To modification these parameters go to **MENU > Home > System Settings > General Setup**.

4.1 SYSTEM

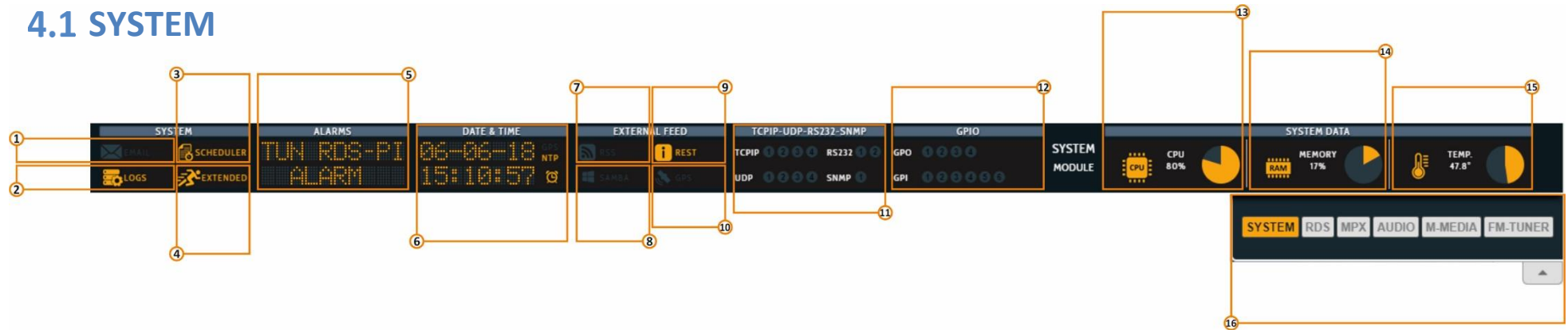

- 1. Email enabled (SMTP):** By active this service the device will send you critical reports by E-Mail scheduled. You can activate it from: [MENU > Home > System Settings > SMTP](#).
- 2. LOGS status LED.**
- 3. Scheduler status.**
- 4. Extended RDS status.**
 To enable/disable this Extended RDS go to: [RDS/RBDS > Basic Settings > RDS Settings > RDS Global Extended Mode](#).
- 5. ALARMS:** The alarms that turn in this field are, **NTP Alarm**, **GPS Alarm**, **SMB Alarm**, **RDS OFF** and **RDS Sync**.
 - To see them, the relative alarms must be [unmasked](#).
 - And an error condition must be [created](#).
- 6. Here can view Date and Time.**
 Indicator of active/not active **NTP** Server (Network Time Protocol) go to: [MENU > Home > System Settings > NTP > Ntp On](#).
 Indicator of active/not active **GPS** device (Global Positioning System) go to: [System Settings > GPS > General Settings > GPS On](#).
 Indicator of active/not active **UTC** (Universal Time Coordinated) go to: [MENU > Home > System Settings > GPS > Get UTC from GPS](#).
- 7. RSS FEED Status.**

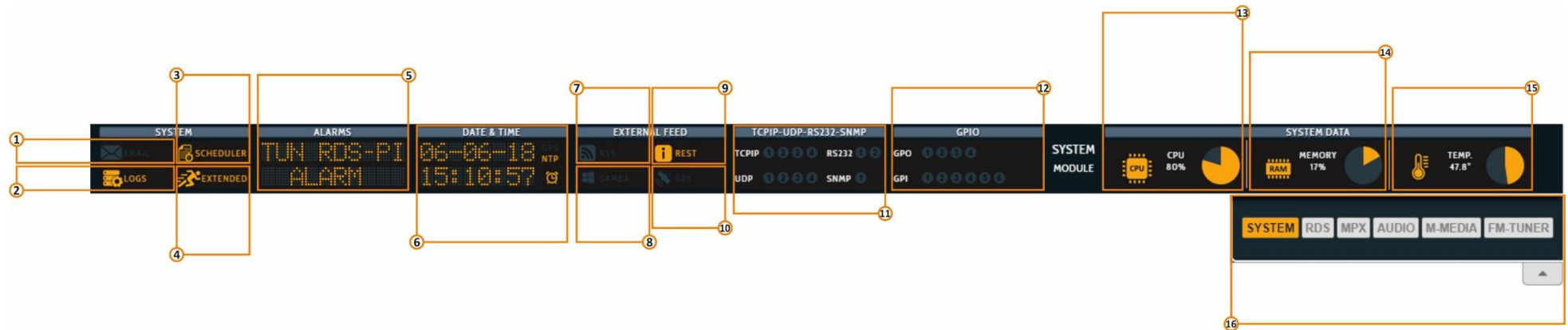

8. **SAMBA server Status:** From here can verify if **SMB protocol/SAMBA server** is active. This does not indicate the connection status to the server.
To active it, follows these steps: [MENU > Home > System Settings > General Setup > SMB/SAMBA Share Settings](#).
9. **REST API Status:** Representational state transfer (REST) is a software architectural style that defines a set of constraints to be used for creating Web services. To change it go to [MENU > Home > System Settings > General setup > rest settings](#).
10. **GPS:** . This does not indicate the connection status. to enable/disable it go to [MENU > Home > System Settings > GPS](#).
11. **TCP/IP:** You can set this device to a maximum of **3 TCP/IPv4** and **2 TCP/IPv6**.
SERIALS: You can connect the device to a maximum of 2 Serial devices.
UDP: You can connect the device to a maximum of 4 UDP devices. The related led lights up when UECP packets are received.
SNMP: (Simple Network Management Protocol) The lights up when SNMP UECP packets are received.
12. **GPO:** You can connect the device to a maximum of 4 GPO devices (GPO1, GPO2, GPO3, GPO4). These LEDs indicate the status of the related GPO device. To set GPO settings go in [MENU > Home > System Settings > GPIO > GPO \(1/2/3/4\)](#) and in [MENU > Home > System Settings > GPIO > GPO Event Notification](#). GPO1, GPO2, GPO3, GPO4.
GPI: you can connect a maximum of 6 GPI devices. These LEDs light up when the related GPI device is turned on.
13. Here you can view the statistics connected with the **CPU** usage.
14. Here you can view the statistics connected with the **Memory** usage.
15. Here you can view the statistics connected with the system **temperature**.
16. From this slide **banner**, you can select which sections of the mask you want to view.

4.2 RDS MODULE



1. RDS output signal:

the intensity in mV (millivolt peak to peak).

to customize it go to: [RDS/RDBS > Basic Settings > Rds Settings > Rds Levels](#).

2. Phase:

The RDS signal must respect a phase criterion (in phase or in quadrature) with the **19 kHz** pilot tone. Here you can see the actual phase of your RDS signal. You can find it in [RDS/RBDS > Basic Settings > Rds Settings > Rds Levels > Phase\(Deg\)](#).

3. SYNC:

Synchronism between RDS signal and pilot frequency.

Int: internal pilot managed by the unit.

EXT: external pilot (Sync In, MPX in).

LOCK: it is to indicate if the external pilot is locked or not.

to customize it go to: [RDS/RDBS > Basic Setting > Rds General Setting > Rds Synchronism](#).

4. ON AIR GROUPS:

Here you can view **RDS** groups sequence ONAIR. You can read all the enabled **RDS** groups.

5. PS-DS-PI-DI:

PS: (Program Services Name). to customize it go to: [RDS/RBDS > Standard Mode > Uecp Main PS > Basic Settings](#).

DS: (Data Set) you can select one from **8 Dataset**, all of them are configurable. [RDS/RBDS > Basic Settings > Rds Setting > Active Dataset Selection](#).

PI: (Program Identification code) allows the radio to display the name of the radio station. [RDS/RBDS > Standard Mode > Uecp Main PS > Basic Settings](#).

DI: (Decoder Information/Identification). The Decoder Identification identifies different operating modes. This enables controlling of individual decoders. Additionally, it indicates if static or dynamic **PTY** codes are transmitted. For example:

- Mono or Stereo
- Artificial Head, No Artificial Head
- Compressed, Not Compressed
- Static **PTY** Codes, Dynamic **PTY** Codes

The decoder information is transmitted in the groups 0A, 0B and 15B. [RDS/RBDS > Standard Mode > Uecp Main PS > Basic Settings](#).

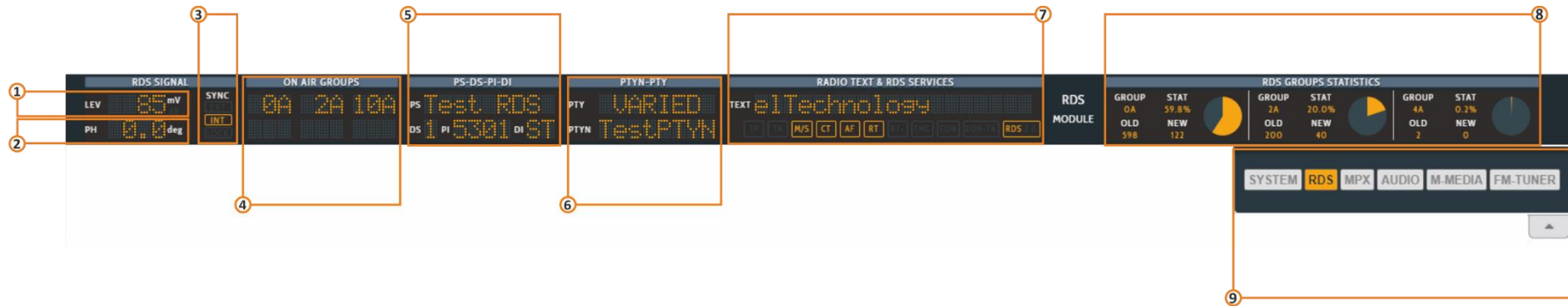

- 6. **PTY:** (Program Type) This is an identification number to be transmitted with each program item and which is intended to specify the current Program type within 31 possibilities.
PTYN: (Program Type Name) The **PTYN** feature is used to further a more specific **PTY** description that the broadcaster can freely decide (e.g. **PTY**=4: Sport and **PTYN**: Football).
 to customize it go to: [RDS/RBDS > Standard Mode > Uecp Main PS > Basic Settings](#).
- 7. **RADIO TEXT:** Some receivers do not support the Radio text service. The text can be up to 64 characters long. if your text more than 64 characters you will get an error message. Watch the next figure. To add a new text, follow these steps: [RDS/RBDS > Standard Mode > Uecp Radiotext > Radiotext](#).

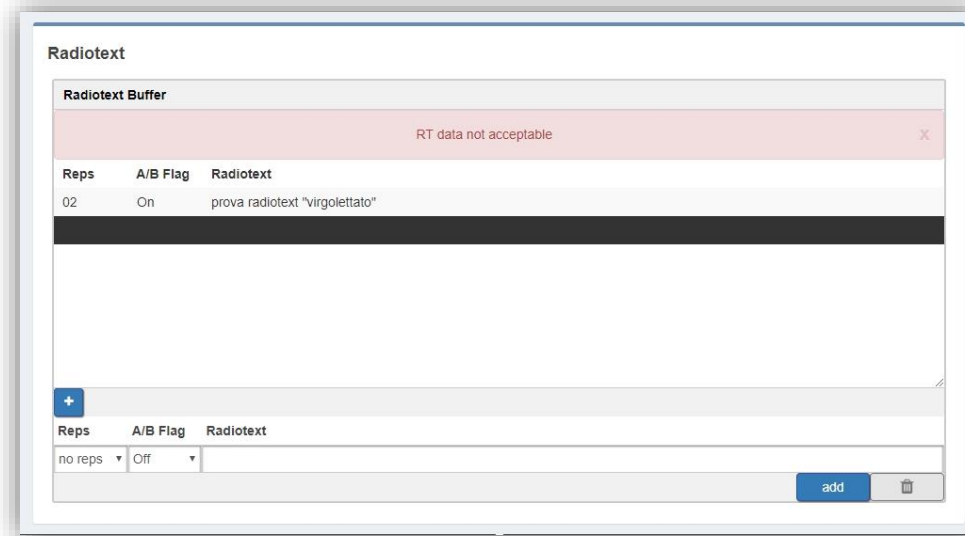



RDS SERVICES:

TP: (Traffic Program Identification) to activate it go to: [RDS/RBDS > Standard Mode > Uecp Main PS > Basic Settings](#).

TA: (Traffic Announcement identification) to activate it go to: [RDS/RBDS > Standard Mode > Uecp Main PS > Basic Settings](#).

M/S: (Music / speech switch) to activate it go to: [RDS/RBDS > Standard Mode > Uecp Main PS > Basic Settings](#).

CT: (Clock-Time and Data) to activate it go to:

AF: (Alternative frequencies list) to activate it go to: [RDS/RBDS > Standard Mode > Uecp Main AF > Alternative Frequencies](#).

RT: (Radiotext) to customize it go to: [RDS/RBDS > Standard Mode > Uecp Radiotext > Radiotext](#).

RT+: (Radiotext Plus) to customize it go to:

TMC: (Traffic Information via Traffic Message Channel) to activate it go to: [RDS/RBDS > Standard Mode > Uecp Main PS > Slow Labelling Codes](#).

EON: (Enhanced Other Networks Information) to customize it go to: [RDS/RBDS > Standard Mode > Uecp Eon PS > Eon Basic Settings](#).

EON-TA: (The Traffic Announcement Identification Flag of the other program can be transmitted via EON) to customize it go to: [RDS/RBDS > Standard Mode > Uecp Eon PS > Eon Basic Settings](#).

RDS 2.0:

8. **RDS GROUPS STATISTICS:** Here you can view a rotation with the statistics of the active groups.
9. From this banner, you can select which sections of the mask you want to view.

4.3 AUDIO MODULE

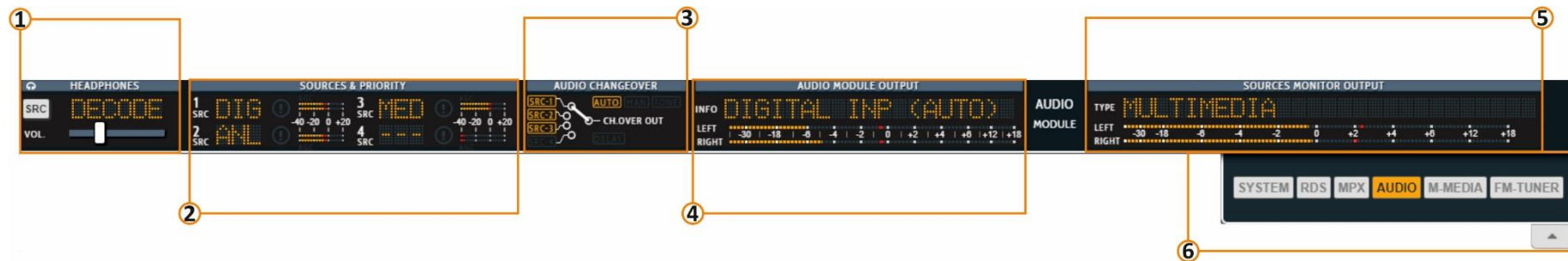

1. HEADPHONES

Here you can set the Headphones level and the Source. To change the Headphone Source, click on the **SRC button** until you reach the desired source. To change the level, move the horizontal slider. You can select between **ANALOG**, **DIGIT1** (digital-1), **DIGIT2** (digital-2), **AUDSEL** (Audio Selector), **WBPROC** (WIDE BAND PROCESSOR), **DECODE** (MPX DECODER), **MMEDIA** (MULTIMEDIA), **COMP** (COMPOSIT).

2. SOURCES & PRIORITY

Here you can have an overview of the 4 audio sources and levels of the audio changeover. To change **SRC-1**,, **SRC-4** go to [Audio Input > Audio Selector > Sources](#).

3. AUDIO CHANGEOVER

Here you can see which audio source is selected by the **Audio-Changeover**. You can see if the Audio-Changeover is in Automatic mode, Manual mode or if it is selecting the Tone Generator.

- To select the Audio Changeover Mode, go to [Audio Input > Audio Selector > Configuration > Mode](#). You can choose between **Source1**(manual mode), **Source2**(manual mode), **Source3**(manual mode), **Source4**(manual mode), **Generator**(tone) and **Automatic Changeover**.
- To set the milliseconds of the delay go to [Audio Input > Changeover > Audio Changeover > Delay Time](#).

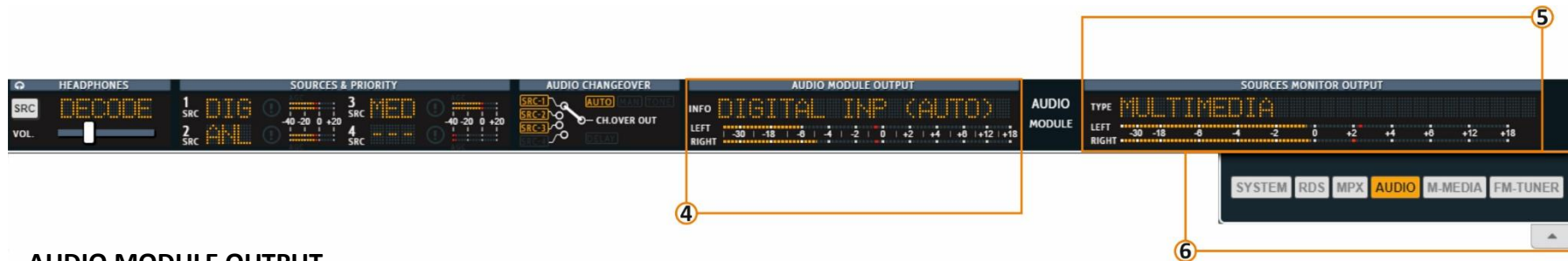

4. AUDIO MODULE OUTPUT

From this section, you can view the selection made by the audio changeover, the audio changeover mode and levels.

- To set the Audio Changeover Mode go to [Audio Input > Audio Selector > Configuration > Mode](#). Here you can choose **AUTO** for an automatic choice between the valid sources, or you can force the choice of selecting the desired source. If you select **Generator**, here you will read **REF-TONE xxxkHz**.
- Can change the generator tone frequency **30Hz - 15KHz** from [Audio Input > Sources > Audio Generator > Configuration > Freq.](#)
- To set the **mode** of the tone generator, go to: [Audio Input > Sources > Audio Generator > Configuration > Mode](#).
- And to set the **level** of the tone generator, go to: [Audio Input > Sources > Audio Generator > Configuration > Level](#).
- To change the audio sources for the **Source1, ..., Source4, Generator** or **Automatic Changeover** go to: [Audio Input > Audio Selector > Configuration > Mode](#).

5. STREAMING MONITOR OUTPUT

Here you can monitor the source and level of Streaming output.

- To select the desired Audio Streaming output source, go to [Audio Output > Streaming Monitor > Configuration > Streaming Monitor Sources](#).
 - To set the Streaming Monitor level go to [Audio Output > Streaming Monitor > Configuration > Streaming Monitor Level](#).
6. From this banner, you can select which sections of the mask you want to view.

4.4 MPX MODULE (NOT IN FALCON D7)

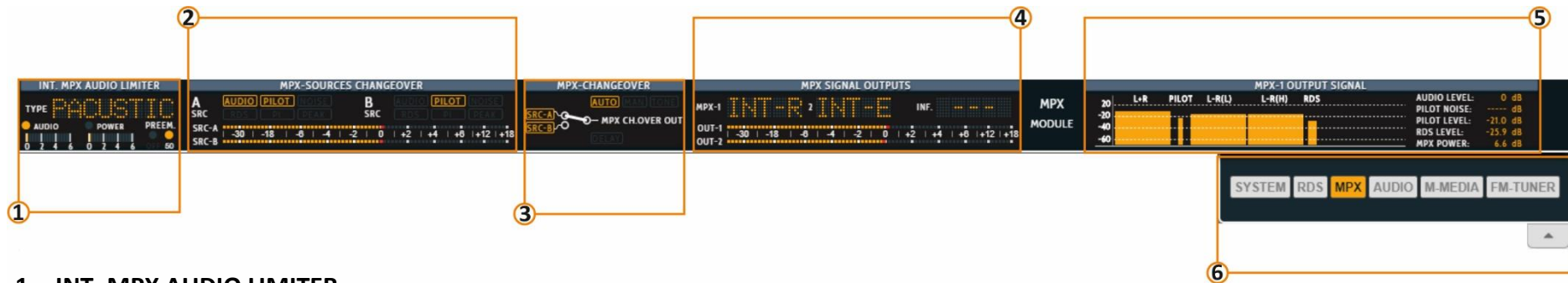

1. INT. MPX AUDIO LIMITER.

Internal Multiplexing Audio Limiter. As MPX power is a value that is calculated with one minute of integration time, limiting finally is a very complicated task that can control it by this device.

2. MPX-SOURCE CHANGEOVER.

From the image below, you can see how the **MPX CHANGEOVER** can choose between two different sources: **SOURCE-A** and **SOURCE-B**. Each of the two sources can choose to compose its own signal by combining the following possible choices:

- MPX signal encoded internally.
- RDS signal encoded internally.
- an auxiliary MPX signal (AUX-1, AUX-2) composed of MPX and RDS or **digital** (AUX-3) . By the action of an RDS UECP FILTER, it's possible to replace to some of its RDS services with some RDS services encoded inside the device.

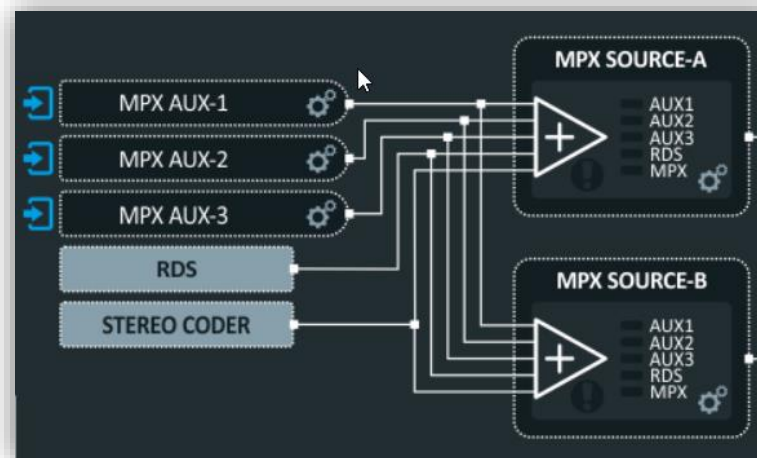



MPX-SOURCES:

In this section, it is possible to see the **SOURCE-A** validation controls. To turn on its Validation Controls go to [MPX > Changeover > Source A > MPX Source A Validation](#). Yellow is valid, red is invalid.

In this section, it is possible to see the **SOURCE-B** validation controls. To turn on its Validation Controls go to [MPX > Changeover > Source B > MPX Source B Validation](#). Yellow is valid, red is invalid.

From this Led Meters, you can see the **Source A** levels and the **Source B** levels.

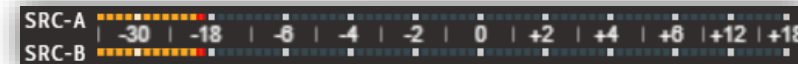
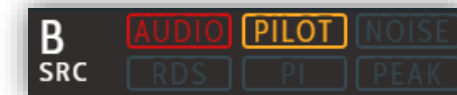
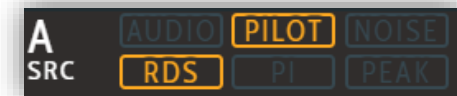

MPX Source A Validation

Pilot Min Level Control	Off	Pilot Min Level Failure Time (Hold)	+5 sec	Pilot Min Level Return Time (Validation)	+5 sec
RDS Min Level Control	Off	RDS Min Level Failure Time (Hold)	+5 sec	RDS Min Level Return Time (Validation)	+5 sec
Narrow Pilot Noise	Off	Out of Band Noise	Off	Noise Observation Window Time	+20 sec
Peak Max Control	Off	Peak Observation Window Time	+20 sec		
RDS PI Validation (Decoded Aux1) 0000					
RDS PI Validation					
MPX Audio Level Control	Off	MPX Audio Level Failure Time (Hold)	+6 sec	MPX Audio Level Return Time (Validation)	+21 sec
Mpx Audio Alarm forced by Audio Changeover Failure Disabled					

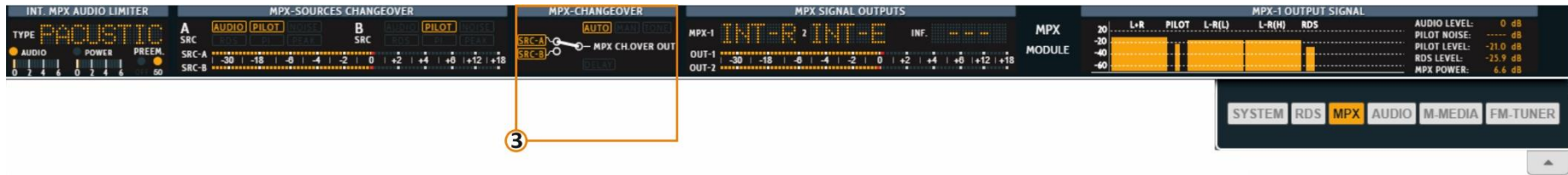

3. MPX-CHANGEOVER:

To set the operating mode of the MPX-Changeover go to **MPX > Changeover > Mode > Configuration**. The changeover **MODE** it could be **SourceA**, **SourceB** or **Auto**.

To set the delay at the FM signal can go to **Audio Output > FM Process > Setup > Delay**.

Here can set the delay up to 10 sec. This delay is used to align **FM broadcasts** with **DAB broadcasts**

Since **DAB** is delayed due to Encoding. Can delay the **FM signal** so that when the car radio switches from **DAB to FM** or vice versa the two signals are aligned.

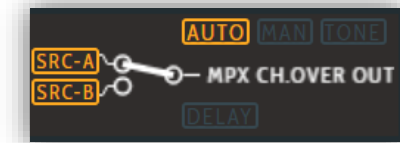

There are three MPX outputs in the device (MPX1, MPX2 and DIGITAL MPX3). In this section, you can view what is routed on the individual outputs.

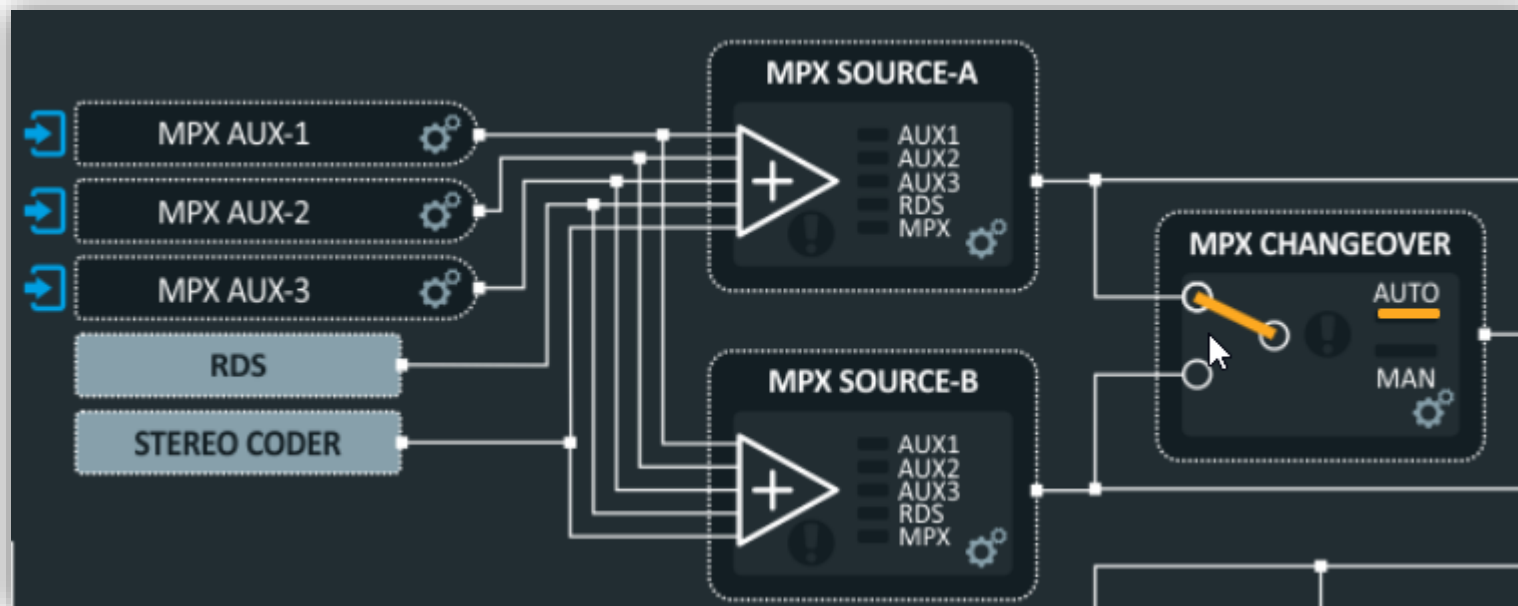

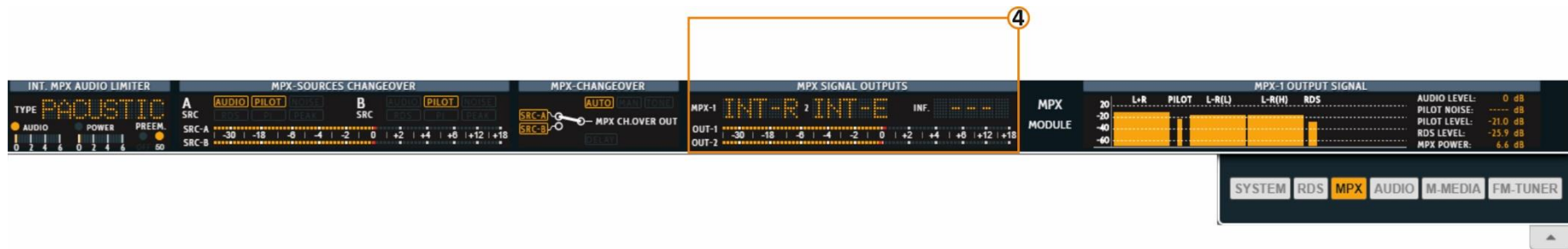

4. MPX SIGNAL OUTPUT

MPX-1: Here you can read what is routed to MPX OUT-1, to change it go to [MPX > Outputs > MPX Output 1 > Source](#).

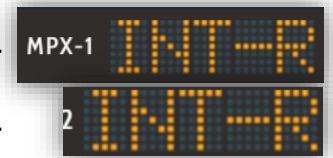

MPX-2: Here you can read what is routed to MPX OUT-2, to change it go to [MPX > Outputs > MPX Output 2 > Source](#).

MPX-3: can route to **DIGITAL MPX OUT-3** one of the two analog MPX1 or MPX2, to change it go to [MPX > Outputs > MPX Output 3 > Source](#).

INF.: To change the preemphasis of the coded MPX signal, go to [MPX > Internal MPX Encoder > Preemphasis](#).

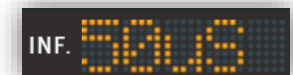

OUT-1, OUT-2: From this Bar Meters you can see the **MPX** Output levels. To change the MPX output level go to [MPX > Outputs > MPX Output 1, 2, or 3 > Level](#).

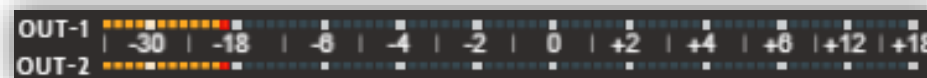



5. MPX-1 OUTPUT SIGNAL

Here you can see levels of the individual parts of the **MPX** Signal that you are routing to the MPX-1 Output. To change the **MPX1** source go to [MPX > Outputs > MPX Output 1 > Source](#).

Mpx Output 1

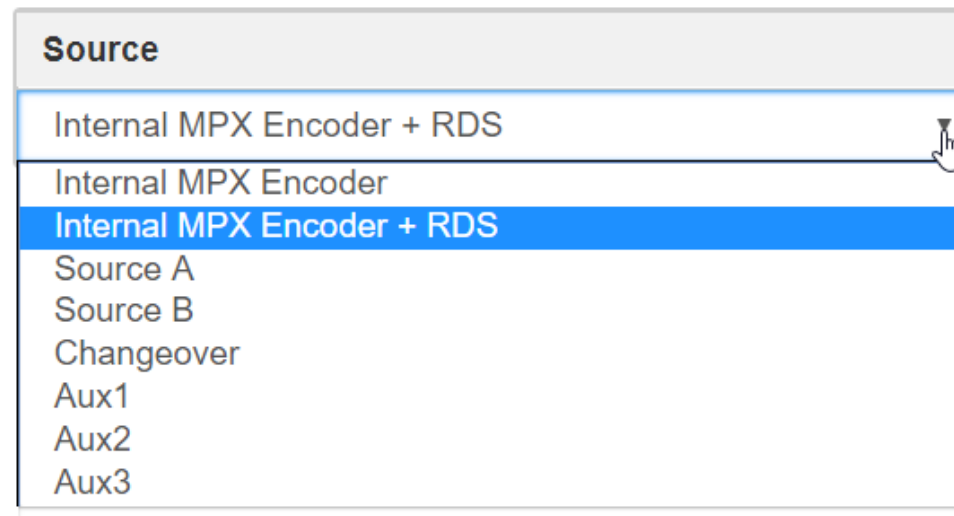

The **INTERNAL MPX ENCODER** receives the audio from **FM Audio Process**, **FM Delayed Process** or **Direct Source**. by going to [MPX > Internal MPX Encoder > Setup > Internal Mpx Generator Source](#).

Direct Source can set as an **Analog Input**, **Digital 1 Input**, **Digital 2 Input**, **Multimedia Input**, **MPX Decoder** or **Generator** by going to [Audio output > Direct Source > Monitor Source](#).

4.5 OUTPUT MODULE

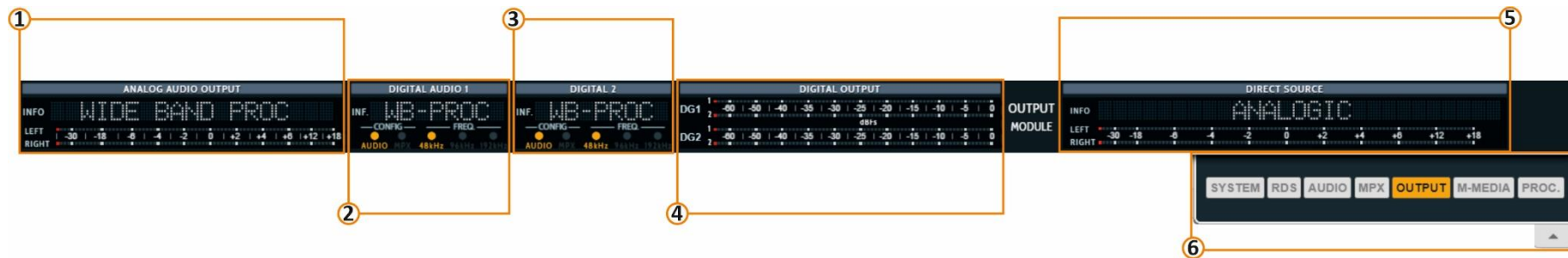

1. **ANALOG AUDIO OUTPUT:** here can check the analogue audio output left and right. To change the source, go to [MENÙ > Home > Analoge](#). The source can receive an audio signal from **Wide Band Process** (for DAB, HD radio), **FM Audio Process**, **FM Delayed Process** or **Direct Source**.
2. **DIGITAL AUDIO 1:** here can check the digital audio output (ch1 and ch2). To change the source, go to [MENÙ > Home > Audio Output > Digital Output 1 > Source](#). from this path is also can change the **Rate** and **Level**.
3. **DIGITAL AUDIO 2:** here can check the digital audio output (ch1 and ch2). To change the source, go to [MENÙ > Home > Audio Output > Digital Output 2 > Source](#). from this path is also can change the **Rate** and **Level**.
4. **DIGITAL OUTPUT:** From this Bar Meters you can see the **Digital Outputs Leve**. To change the MPX output level go to [MPX > Outputs > MPX Output 1, 2, or 3 > Level](#).
5. **DIRECT SOURCE:** here can check the digital audio output (ch1 and ch2). To change the source, go to [MENÙ > Home > Audio Output > Direct Source > Source](#).
6. From this banner, you can select which sections of the mask you want to view.

4.6 MULTIMEDIA MODULE (OPTIONAL)

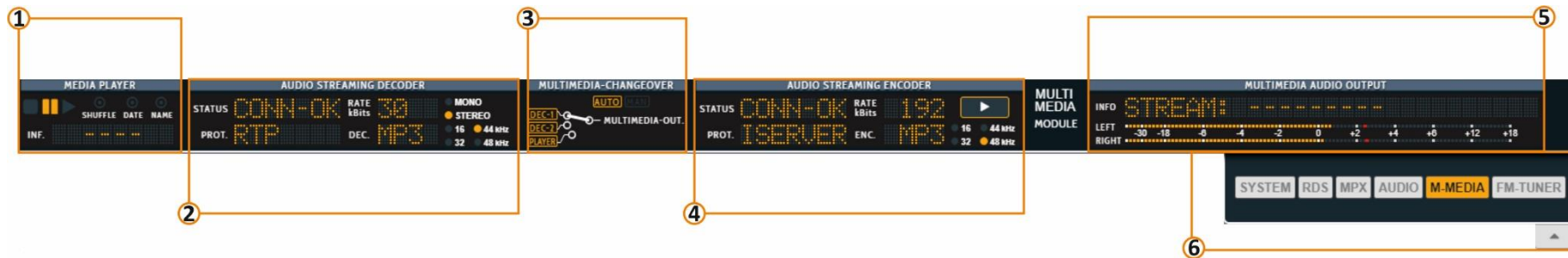

Multimedia Module is an optional plugin.

This device contains an optional **MEDIA PLAYER MODULE**, two Audio Streaming Decoder and also equipped with Audio Streaming Encoder. All this function gives you the ability to select your source from various destinations. From Multimedia Changeover you can choose between **Auto**, **Decoder1**, **Decoder2** or **File Player**.

- 1. MEDIA PLAYER:** It is to play the multimedia files like (MP3, WAV, mp2, OGG VORBIS, AAC, RAW 16bit) by lunch it into the device through the **FTP Client**. The device will automatically create your playlist by **NAME**, **DATA** or **SHUFFLE** from the path **MENÙ > Home > Multimedia > Play Order**.
The playlist will start playing when the media player is select by the MULTIMEDIA CHANGEOVER.
INF. It is to show you the audio compression.
The name of the song in play will show up in section **5** of the canvas.
- 2. AUDIO STREAMING DECODER:** this module is supported by two audio streaming decoders. When one of the decoders is selected by the MULTIMEDIA CHANGEOVER In this section you can monitor the source status.
STATUS: the status of the decoder is selected by the MULTIMEDIA CHANGEOVER.
PROT.: network control protocol.
DATA kBits: the number of bits per second decoded.
DEC.: Decoding extensions.
- 3. MULTIMEDIA CHANGEOVER:** Here you can monitoring your multimedia changeover position and mode AUTO/MANUAL. [Multimedia > Changeover > Configuration](#).

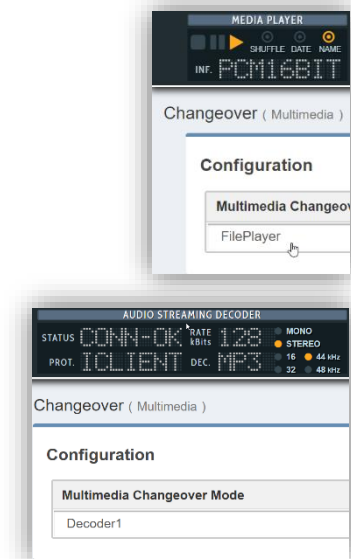

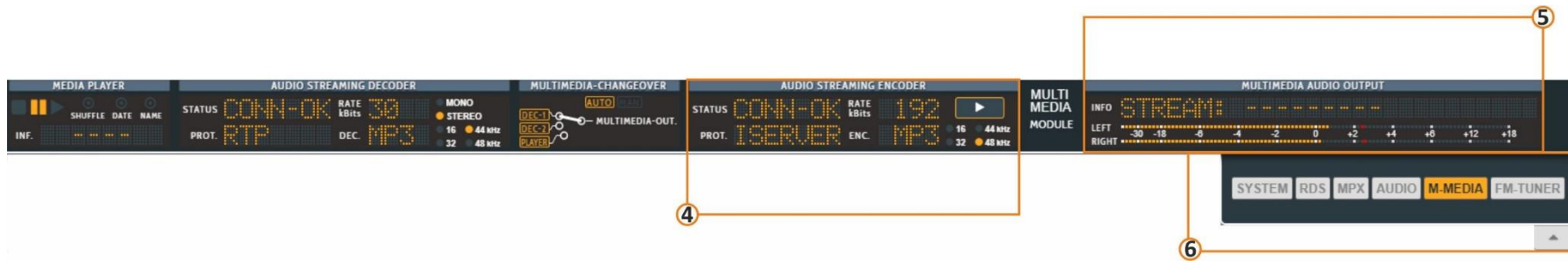

4. **AUDIO STREAMING ENCODER:** to monitoring the audio encoder status. utilizes a buffering system and a secure data stream platform to allow you and the end users to listen to full audio files via network.
STATUS: the status of the Encoder.
PROT.: network control protocol.
DATA kBits: the number of bits per second encoded.
DEC.: Decoding extensions.
Play button: this button works only with the last 3 Icecast Server options. [Multimedia > Stream Encoder > Configuration > Mode.](#)
5. **MULTIMEDIA AUDIO OUTPUT:** it is to monitor the final audio output of the MULTIMEDIA MODULE.
INFO: show up the source selected and the file name.
LEFT/RIGHT: stereo audio level.
6. From this banner, you can select which sections of the mask you want to view.

Stream Encoder Settings (Multimedia)

Status

Status	Protocol	Encoder	BitRate	Mode	Freq
Connected	Icecast Server	MP3	128kBits	Stereo	32 KHz

4.7 PROCESSOR

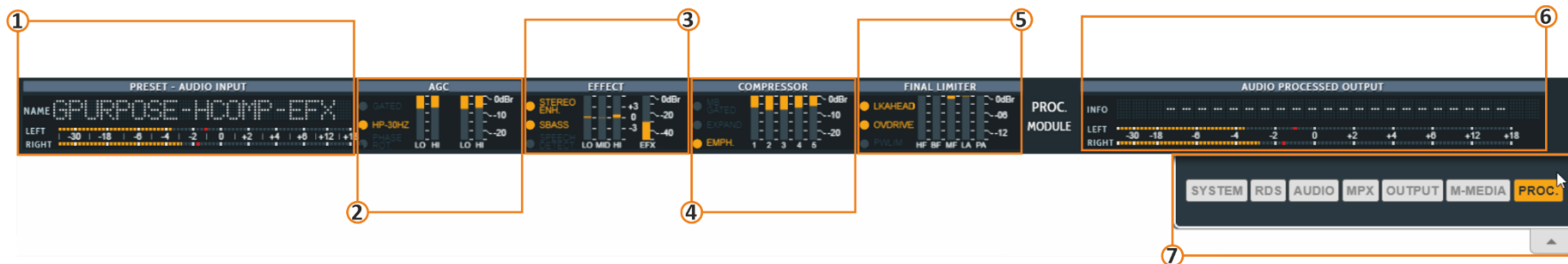

- 1. PRESET – AUDIO INPUT:** The preset name and the stereo audio source level (left, right) entered into the processor appear before processing on a scale from -60 to +18 dB.
- 2. AGC:** Input AGC conditioning, including sample rate conversion, defeatable 30 Hz highpass filtering, and defeatable phase rotation.
 - Gated:** Light up when the **Gated AGC** is used to "roughly" normalize the volume level so that the audio has an approximated constant volume level. This circuit permits automatic gain control to function only during short time intervals.
 - HP-30Hz:** Light up when the defeatable **30 Hz 18 dB/octave** highpass filter will be placed in-circuit before other processing.
 - PHASE ROT.:** Light up when the phase rotator will be in-circuit. The purpose of the phase rotator is to make voice waveforms more symmetrical. This can substantially reduce distortion when they are peak limited.
 All can be controlled from the path [MENÙ > Home > Process > AGC](#).
- 3. EFFECT:**
 - STEREO ENH.:** Light up when the Stereo Enhancer is in act. It is designed to improve the width of stereo mixes and individual sounds in WIDE-BAND or MIDE-HIGH. can be controlled from the path [MENÙ > Home > Process > Enhancer](#).
 - SBASS:** Light up when the **(SuperBass)** The SuperBass parameter acts directly on the compression of low frequencies below **100 Hz**. The maximum compression available is **15 dB**. can be controlled from the path [MENÙ > Home > Process > Limiters](#).
 - SPEECH DETECT:** Light up when the speech detector is in use. This function is a key operating parameter for the audio processor. The speech detector function is a key operating parameter for the audio processor. can be controlled from the path [MENÙ > Home > Process > Enhancer](#).

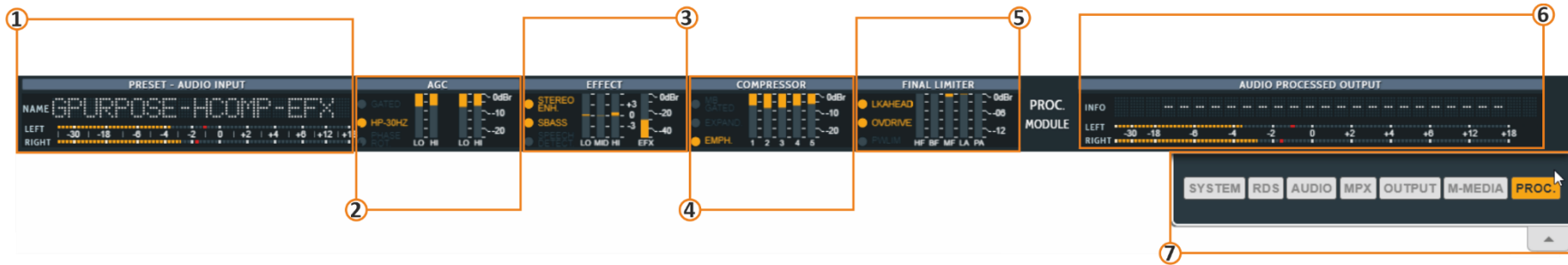

4. **COMPRESSOR:** Full-band (5 band) control compression is one of the most powerful processing techniques available to the recording engineer. This bar graph shows the amount of intervention on each single compressor band, the limiting introduced by the multiband limiter.

Compression reduces the dynamic range of the audio slowly, in a manner similar to an operator riding the gain. Compression is usually performed on the RMS level of the audio waveform and is usually gated to prevent ‘suck-up’ of noise during silence or quiet periods. In addition, compression is usually multi-band.

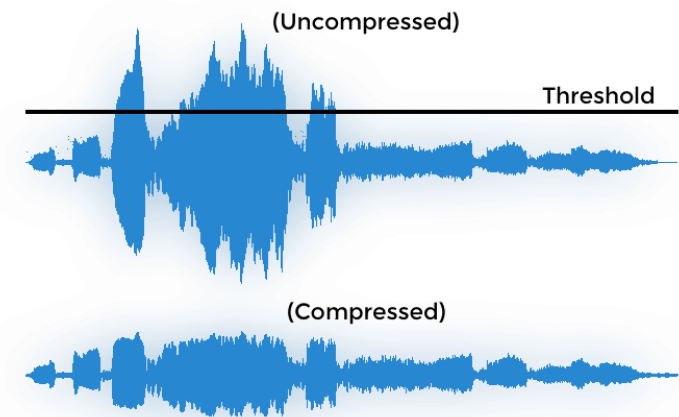

MB GATED:

EXPAND.: The multiband expander is used to reduce the background noise on vocal audio signals or a microphone, or to reduce unwanted effects caused by the introduction of strong compressions.

EMPH.:

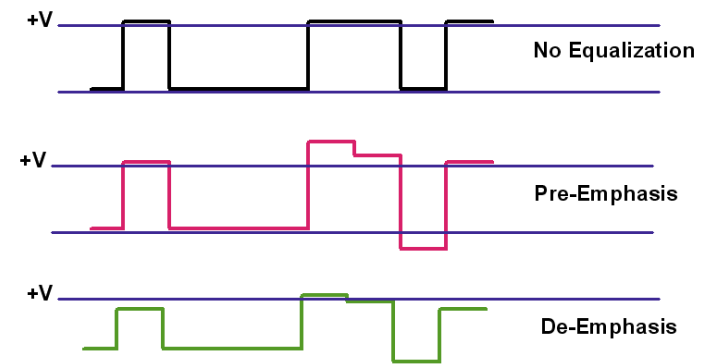

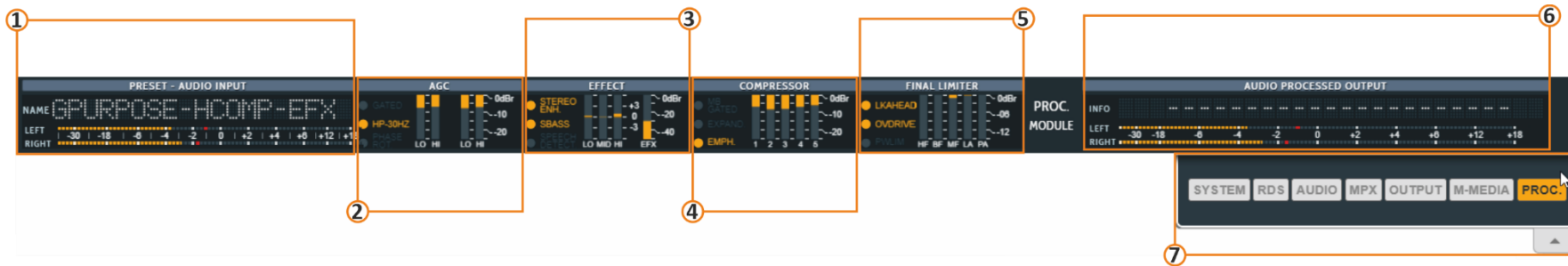

- FINAL LIMITER:** The Final Limiter is the last stage before the MPX stereo encoder, right between the Final Expander and the Power Limiter. Limiters serve a very useful purpose by blocking the parts of a signal that are above a set decibel limit. Similar to compressors, limiters reduce the peaks of a signal above a set threshold. The difference is that compressors reduce the amount of signal above the threshold by a percentage, but limiters do not allow any peaks above the threshold. The names are rather self-explanatory. Limiters are essentially a compressor with a compression ratio of infinity to one. By creating a hard ceiling, limiters prevent peaking. Limiters are often used together with compressors. The compressor is used to create a smooth roll off for sounds above a certain level, while the limiter sets an even higher firm threshold as a final safety net for extremely high peaks.

To set the limiter simply adjust the threshold to the level at which you want the limiter to kick in. This control allows you to increase or decrease the substance of the audio material delivered to the MPX encoder. The term MAIN refers to the fact that it operates on the **350Hz to 15kHz** frequency range. Warning: as already mentioned, it is a very important and powerful command, and so overuse of the Final Limiter Main Drive tends to overwork the "HF", i.e. the Main Final Limiter.

LKAHEAD: Light up when the Lookahead Limiter is active.

OVERDRIVE: Light up when the **OVERDRIVE** Limiter is active. This the amount of signal to apply to the Lookahead module input.

PWLIM:

- AUDIO PROCESSED OUTPUT.**
- From this banner, you can select which sections of the mask you want to view.

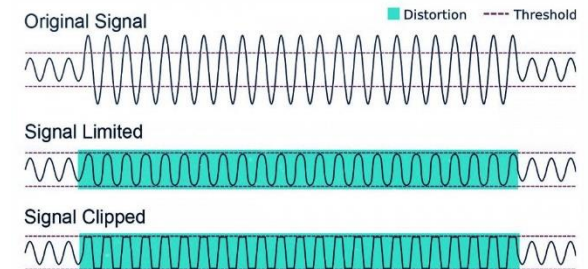

5. MENU

5.1 HOME

If you resize your browser press the top-left button to open the menu:

From here can display the MENU

The screenshot shows the Falcon X7 control interface. At the top left, a 'MENU' button is highlighted with an orange box and an arrow pointing to the text 'From here can display the MENU'. The interface includes several control panels: 'AUDIO SELECTOR' with source selection (ANALOG, DIGITAL-1, etc.), 'AGC' (Automatic Gain Control) with LL LH and RL RH channels, 'ENHANCER' with EFX, 'COMPRESSORS' with 1-5 channels, 'LIMITERS' with BF MF HF LA and POWER, 'AUDIO OUTPUTS' with DIGITAL1 (WB-PROC), DIGITAL2 (FM-PROC), and ANALOG (DELAYED FM), 'MPX OUTPUTS' with INT-R, OUT-1, and MPX-1, and a 'MONITOR' section. A status bar at the bottom shows system information like time (15:09:42), date (28-05-20), and status (SYSTEM OK).

Target Localization

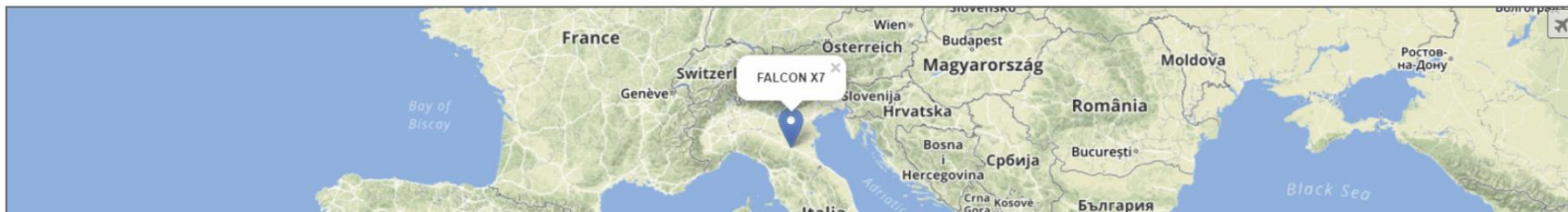

5.2 AUDIO INPUT

5.2.1 SOURCES

COMPLETE SET OF INPUTS, Extended Changeover/Silence Detector with configurable source priorities out of 11 sources: **1xAnalog, 2xAES/EBU, 2xIP, 2xMPX, 1xAES192, 1xDante***, **1xMPX over Dante, 1xInternal Player***.

In this section, you can define parameters connected with (analogic, digital, multimedia and mpx decoder). The changeover can choose between one of the following sources.

5.2.1.1 ANALOG

Sensitivity: sensitivity of the input level. (In example: if a signal of -6.00 dBu arrives, this parameter has to be set on -6.00 dBu).

Mode:

Stereo: the sound is reproduced in his both left and right channels.

Mono: the sound is reproduced only in one channel in monophonic way.

Mono-Left: the left channel of the input signal is reproduced in monophonic way.

Mono-Right: the right channel of the input signal is reproduced in monophonic way.

Swap Left-Right: the left and right channels are swapped. The left becomes the right, and the right becomes the left. The sound is reproduced in stereophonic way.

Inv Left: the sound is reproduced in stereophonic way, but the phase of the left channel is inverted.

Inv Right: the sound is reproduced in stereophonic way, but the phase of the right channel is inverted.

Input Clipping Point: moves the clipping point level. If Sensitivity ≤ 9 we suggest keeping the Input Clipping Point=+15 dBu. If Sensitivity > 9 we suggest keeping the Input Clipping Point=+24 dBu.

AGC

This setting helps balance the audio level. Some of the analogue conventional and trunked radio systems do not include components with **AGC Automatic Gain Control** to help normalize the audio levels of analogue transmissions in the system. This can result in a low-level audio signal if a user on the system is not speaking close enough to their radio microphone.

AGC Speed: gain speed of action.

AGC Absolite Range: this parameter rules the maximum gain to apply on the received signal.

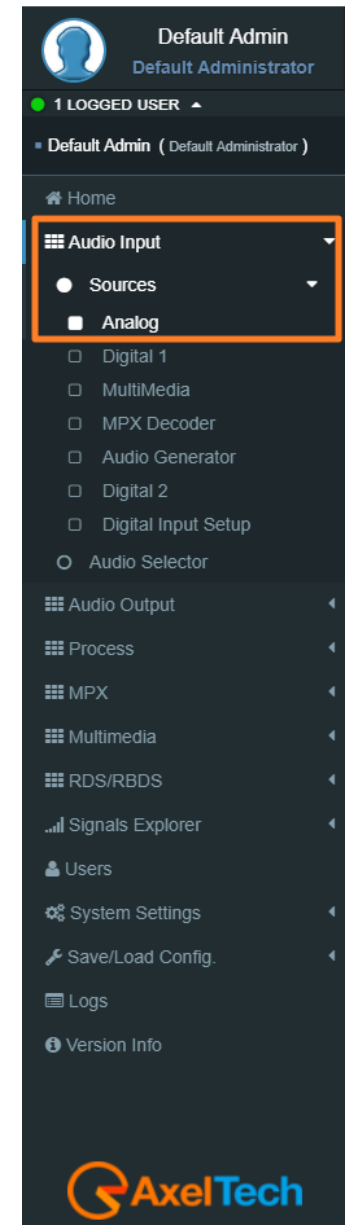

VALIDATION

In this section, it is possible to manage the parameter for the signal validation.

The CHANGEOVER looking at these parameters can consider valid or not the source.

Threshold: the source is considered invalid if the signal is lower than this value for the time typed in *Validation* parameter.

Hysteresis: the source is considered valid if the signal is higher than *Threshold + Hysteresis* for the time typed in *Hold*.

Failure Time (Hold): the source is considered valid if the signal is higher than *Threshold + Hysteresis* for the time typed here.

Return Time (Validation): the source is considered invalid if the signal is lower than *Threshold* for the time typed here.

Audio Failure Search: This function enables statistical research of small audio holes inside the audio signal. Useful to recognize corrupted decoded audio from satellite or digital links.

For a General Purpose, we suggest you choose the **Mode 2**.

For a musical radio, we suggest you the **Mode 1**.

For a talk radio, we suggest you the **Mode 3**.

Off: this function is off.

Mode 1: *silence blocks window*=80ms, *Percentage*=10%, *Time*=30secs (Music).

Mode 2: *silence blocks window*=120ms, *Percentage*=15%, *Time*=30secs (General Purpose).

Mode 3: *silence blocks window*=180ms, *Percentage*=20%, *Time*=30secs (Talk).

Silence blocks window: seconds of the single audio hole.

Percentage: percentage of *Silence blocks window* that the Changeover has to find in a *Time=Time*

Time: time in which the check is done.

Events

Audio Inp Analog Events

masked

Audio Inp Analog Alarm

Masked/Unmasked: Mask/Unmask the alarm of the Audio Inp Analog Events.

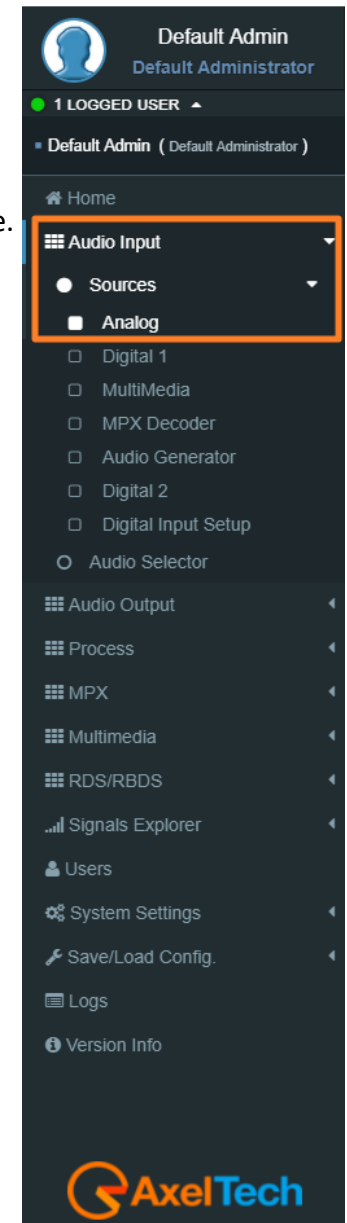

5.2.1.2 DIGITAL

INPUT

Sensitivity: sensitivity of the input level. (For example: if a signal of -6.00 dBu arrives, this parameter has to be set on -6.00 dBu).

Mode:

Stereo: the sound is reproduced in his both left and right channels.

Mono: the sound is reproduced only in one channel in monophonic way.

Mono-Left: the left channel of the input signal is reproduced in monophonic way.

Mono-Right: the right channel of the input signal is reproduced in monophonic way.

Swap Left-Right: the left and right channels are swapped. The left becomes the right, and the right becomes the left. The sound is reproduced in stereophonic way.

Inv Left: the sound is reproduced in stereophonic way, but the phase of the left channel is inverted.

Inv Right: the sound is reproduced in stereophonic way, but the phase of the right channel is inverted.

AGC

Automatic Gain Control This setting helps balance and normalize the audio levels of audio transmissions in the system. Digital radio systems typically do not **AGC** control functionality and tend to reproduce a user's voice audio signal more faithfully with regard to audio levels. This can result in a low-level audio signal if a user on the system is not speaking close enough to their radio microphone.

AGC Speed: gain speed of action.

AGC Range: this parameter rules the maximum gain to apply on the received signal.

VALIDATION

In this section, it is possible to manage the parameter for the signal validation.

The **CHANGEOVER** looking at these parameters can consider valid or not the source.

Threshold: the source is considered invalid if the signal is lower than this value for the time typed in *Validation* parameter.

Hysteresis: the source is considered valid if the signal is higher than *Threshold + Hysteresis* for the time typed in *Hold*.

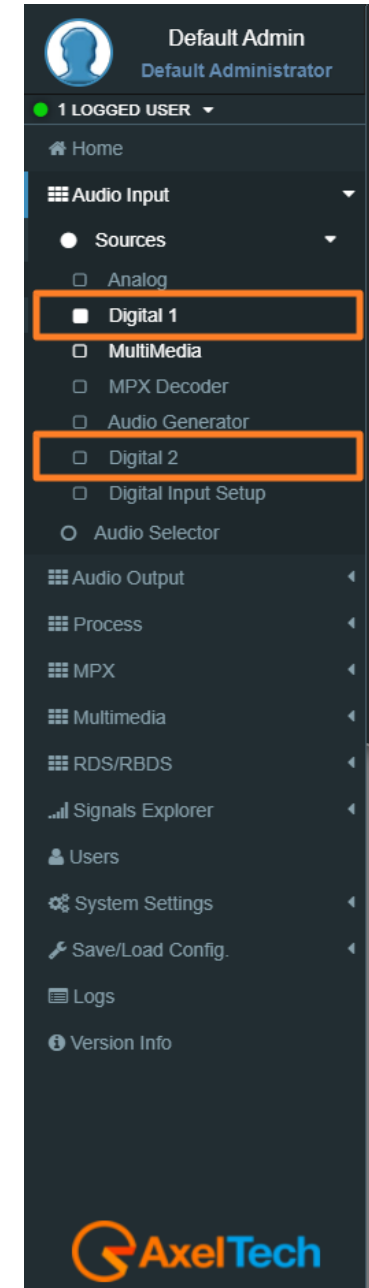

Failure Time (Hold): the source is considered valid if the signal is higher than *Threshold + Hysteresis* for the time typed here.

Return Time (Validation): the source is considered invalid if the signal is lower than *Threshold* for the time typed here.

Audio Failure Search: This function enables statistical research of small audio holes inside the audio signal. Useful to recognize corrupted decoded audio from satellite or digital links.

For a General Purpose, we suggest you choose the **Mode 2**.

For a musical radio, we suggest you the **Mode 1**.

For a talk radio, we suggest you the **Mode 3**.

Off: this function is off.

Mode 1: *silence blocks window*=80ms, *Percentage*=10%, *Time*=30secs (Music).

Mode 2: *silence blocks window*=120ms, *Percentage*=15%, *Time*=30secs (General Purpose).

Mode 3: *silence blocks window*=180ms, *Percentage*=20%, *Time*=30secs (Talk).

Silence blocks window: seconds of the single audio hole.

Percentage: percentage of *Silence blocks window* that the Changeover has to find in a *Time=Time*

Time: time in which the check is done.

Digital AES:

Validation Off: if Validation Off the signal is always considered valid.

Validation On: if Validation On the signal is considered valid only if it is possible to find the AES EBU digital signal clock and frame format.

Events

Audio Inp Digital Masked/Unmasked: Mask/Unmask the alarm of the Audio Inp Digital.

Audio Aes Digital Carrier Masked/Unmasked: Mask/Unmask the alarm of the Audio Aes Digital Carrier.

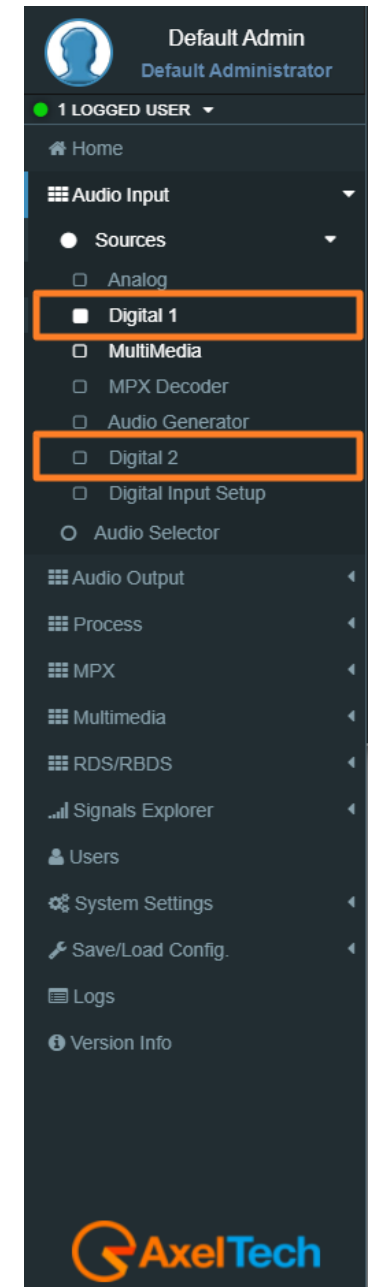

5.2.1.3 MULTIMEDIA (OPTIONAL)

This source depends on the multimedia module. The source is included two **IP Decoder** (audio streaming) and an **audio Player**. The player source is an **SD card** filled in the device with audio files.

INPUT

Sensitivity: sensitivity of the input level. (For example: if a signal of -6.00 dBu arrives, this parameter has to be set on -6.00 dBu)

Mode:-

Stereo: the sound is reproduced in his both left and right channels.

Mono: the sound is reproduced only in one channel in monophonic way.

Mono-Left: the left channel of the input signal is reproduced in monophonic way.

Mono-Right: the right channel of the input signal is reproduced in monophonic way.

Swap Left-Right: the left and right channels are swapped. The left becomes the right, and the right becomes the left. The sound is reproduced in stereophonic way.

Inv Left: the sound is reproduced in stereophonic way, but the phase of the left channel is inverted.

Inv Right: the sound is reproduced in stereophonic way, but the phase of the right channel is inverted.

AGC

AGC Speed: gain speed of action.

AGC Range: this parameter rules the maximum gain to apply on the received signal.

VALIDATION

In this section, it is possible to manage the parameter for the signal validation.

The **CHANGEOVER** looking at these parameters can consider valid or not the source.

Threshold: the source is considered invalid if the signal is lower than this value for the time typed in *Validation* parameter.

Hysteresis: the source is considered valid if the signal is higher than *Threshold + Hysteresis* for the time typed in *Hold*.

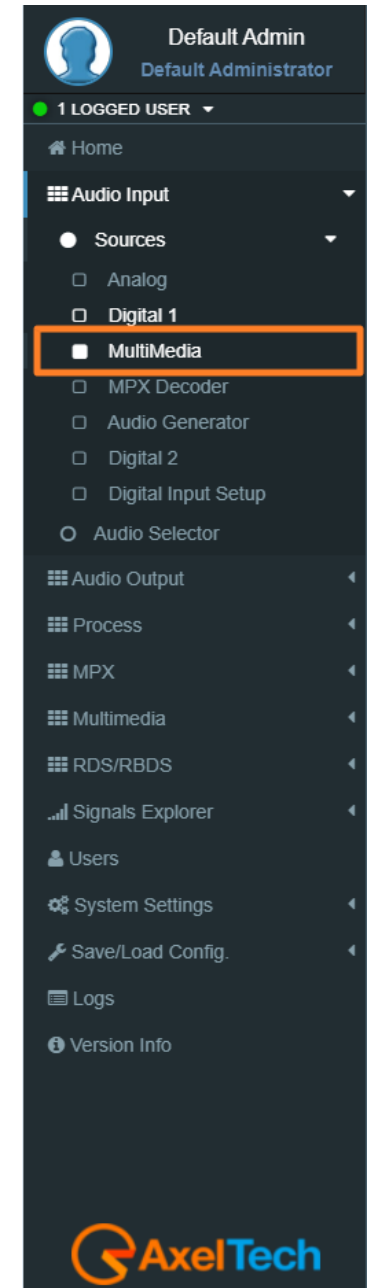

Failure Time (Hold): the source is considered valid if the signal is higher than *Threshold + Hysteresis* for the time typed here.

Return Time (Validation): the source is considered invalid if the signal is lower than *Threshold* for the time typed here.

Audio Failure Search: This function enables statistical research of small audio holes inside the audio signal. Useful to recognize corrupted decoded audio from satellite or digital links.

For a General Purpose, we suggest you choose the **Mode 2**.

For a musical radio, we suggest you the **Mode 1**.

For a talk radio, we suggest you the **Mode 3**.

Off: this function is off.

Mode 1: *silence blocks window=80ms, Percentage=10%, Time=30secs* (Music).

Mode 2: *silence blocks window=120ms, Percentage=15%, Time=30secs* (General Purpose).

Mode 3: *silence blocks window=180ms, Percentage=20%, Time=30secs* (Talk).

Silence blocks window: seconds of the single audio hole.

Percentage: percentage of *Silence blocks window* that the Changeover has to find in a *Time=Time*

Time: time in which the check is done.

Events

Audio Inp Media Masked/Unmasked: Mask/Unmask the alarm of the Audio Inp Media.

Audio Inp Media Events

●	masked	Audio Inp Media Alarm
---	--------	-----------------------

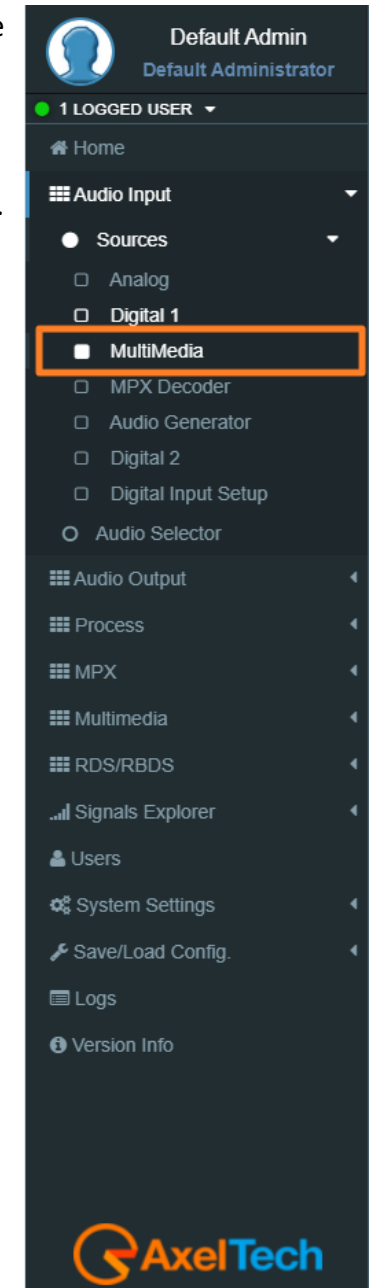

5.2.1.4 MPX DECODER

This source is an MPX decoder, it extracts the L/R channels from the MPX signal.

INPUT

Source: Select here the source for the Mpx Decoder. You can choose between:

- MPX Aux1***
- MPX Aux2***
- MPX Source A***
- MPX Source B***
- MPX Out1***
- MPX Out2***
- MPX Aux3***

Sensitivity: sensitivity of the input level. (For example: if a signal of -6.00 dBu arrives, this parameter has to be set on -6.00 dBu).

Mode:-

Stereo: the sound is reproduced in his both left and right channels.

Mono: the sound is reproduced only in one channel in monophonic way.

Mono-Left: the left channel of the input signal is reproduced in monophonic way.

Mono-Right: the right channel of the input signal is reproduced in monophonic way.

Swap Left-Right: the left and right channels are swapped. The left becomes the right, and the right becomes the left. The sound is reproduced in stereophonic way.

Inv Left: the sound is reproduced in stereophonic way, but the phase of the left channel is inverted.

Inv Right: the sound is reproduced in stereophonic way, but the phase of the right channel is inverted

Deemphasis: Here is possible to select the deemphasis to apply on the signal. It is possible to choose between ***off***, ***50uSec*** and ***75uSec***.

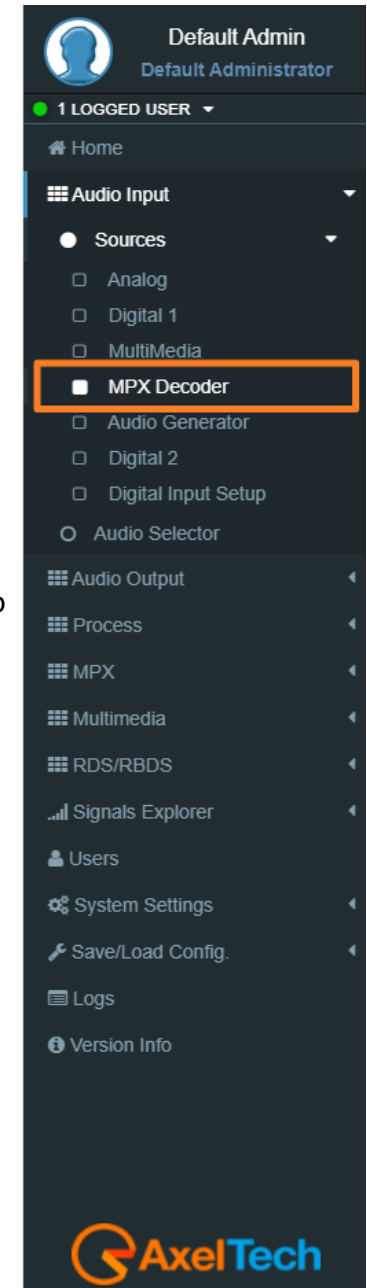

AGC

AGC Speed: gain speed of action.

AGC Range: this parameter rules the maximum gain to apply on the received signal.

VALIDATION

In this section, it is possible to manage the parameter for the signal validation.

The **CHANGEOVER** looking at these parameters can consider valid or not the source.

Threshold: the source is considered invalid if the signal is lower than this value for the time typed in *Validation* parameter.

Hysteresis: the source is considered valid if the signal is higher than *Threshold + Hysteresis* for the time typed in *Hold*.

Failure Time (Hold): the source is considered valid if the signal is higher than *Threshold + Hysteresis* for the time typed here.

Return Time (Validation): the source is considered invalid if the signal is lower than *Threshold* for the time typed here.

Audio Failure Search: This function enables statistical research of small audio holes inside the audio signal. Useful to recognize corrupted decoded audio from satellite or digital links.

For a General Purpose, we suggest you choose the **Mode 2**.

For a musical radio, we suggest you the **Mode 1**.

For a talk radio, we suggest you the **Mode 3**.

Off: this function is off.

Mode 1: *silence blocks window*=80ms, *Percentage*=10%, *Time*=30secs (Music).

Mode 2: *silence blocks window*=120ms, *Percentage*=15%, *Time*=30secs (General Purpose).

Mode 3: *silence blocks window*=180ms, *Percentage*=20%, *Time*=30secs (Talk).

Silence blocks window: seconds of the single audio hole.

Percentage: percentage of *Silence blocks window* that the Changeover has to find in a *Time=Time*

Time: time in which the check is done.

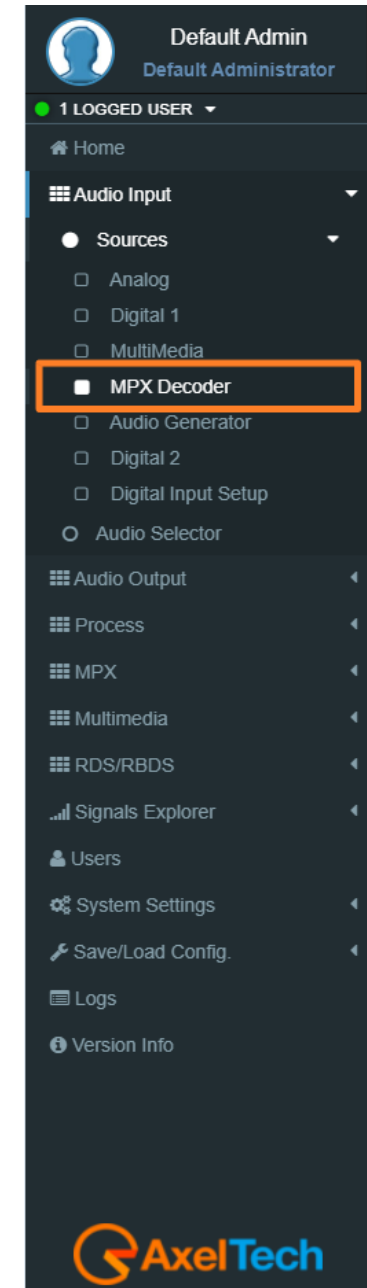

RDS PI Validation: In this field, you can fill the desired RDS PI.

If the RDS PI Validation=0000 the source is not under validation control. the signal is always considered valid.

If the RDS PI Validation=*number* then:

if *RDS PI = number* the source is considered valid.

if *RDS PI ≠ number* all the MPX source is invalidated.

Events

Audio Inp MPX Decoder Masked/Unmasked: Mask/Unmask the alarm of the Audio Inp MPX Decoder.

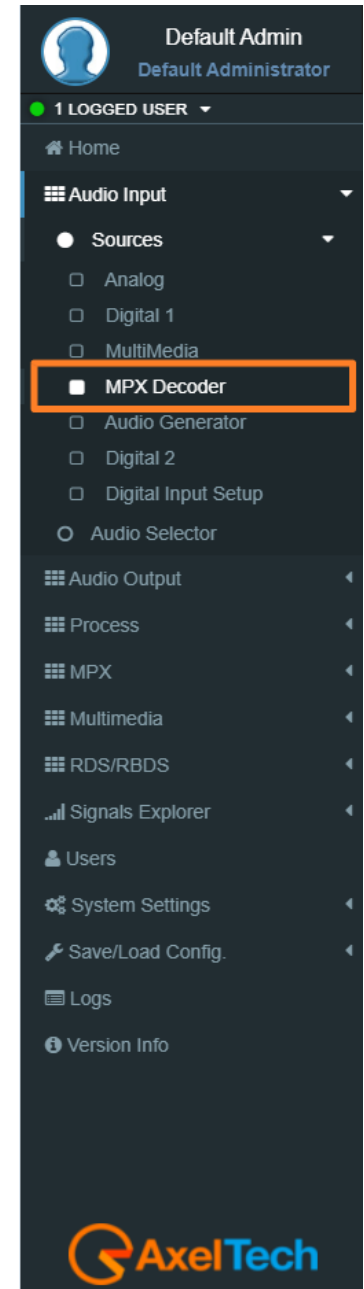

5.2.1.5 AUDIO GENERATOR

FALCON comes with a built-in audio tone generator. The tone range is 30 Hz - 15 kHz. This option is too useful for the tuning instruments, science experiments, testing audio equipment. The Audio Generator module sets the parameters for the internal tone generator.

CONFIGURATION

Mode: this parameter sets the mode with the audio generator generates a tone. The possible modes are

Left=Right: the Left and the Right channels are in phase

Left=-Right: the Left and the Right channels are in reverse phase

Only Left: only the Left channel is available

Only Right: only the Right channel is available

Freq: Select here the frequency of the tone that you want to generate.

Level: select here the level (dBr) of the tone that you want to generate.

5.2.1.6 DIGITAL INPUT SETUP

Here can switch the **DIGITAL-1** between **AES/EBU-1** and **DANTE-1***.

And switch the **DIGITAL-2** between **AES/EBU-2**, **MPX AUX3**, **DANTE-2***.

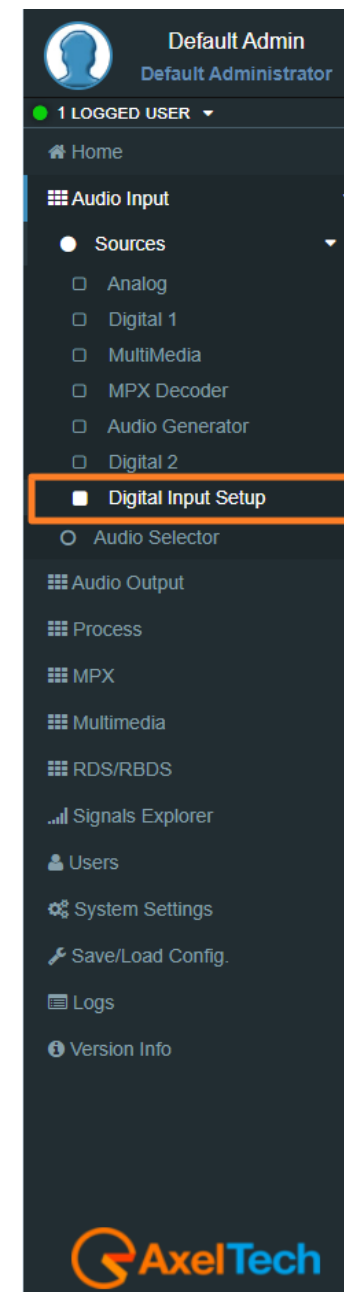
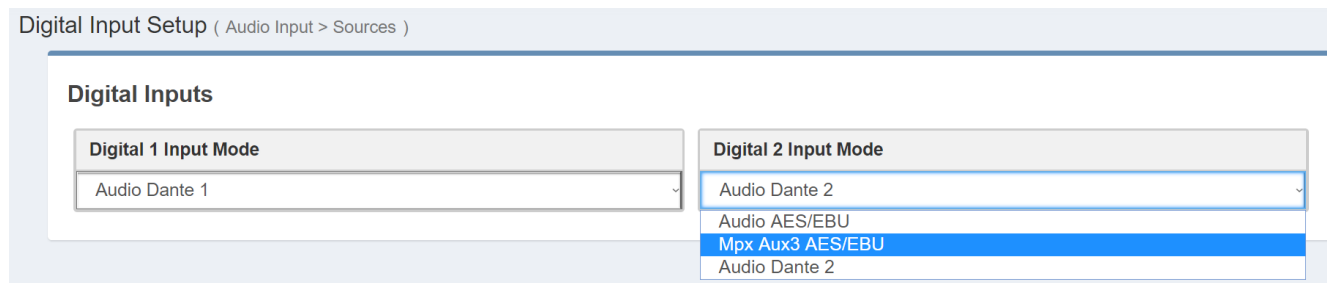

* Optional.

5.2.2 AUDIO SELECTOR

The audio changeover has the task to forward the selected source to the **INTERNAL MPX ENCODER**.

CONFIGURATION

Mode:

- Choose between **Source1**, **Source2**, **Source3**, **Source4** to force the changeover selection. the changeover keeps the source even if It is invalidated.
- Choose **Auto** if you want that the changeover selects the source automatically. If the source is invalidated, the changeover selects the next source available.
- Choose **Generator** if you want to forward at the **INTERNAL MPX ENCODER** the internal **AUDIO GENERATOR** (tone generator).

SOURCES

Sources

Source1 - High Priority	Source2	Source3	Source4 - Low Priority
Analog	Digital 1	MPX Decoder	MultiMedia

Source1: assign here the source you want as the first one (High Priority).

Source2: assign here the source you want as the second one.

Source3: assign here the source you want as the third one.

Source4: assign here the source you want as the fourth one (Low Priority).

Events

Audio Changeover Events

<div style="display: flex; align-items: center;"> ● unmasked </div>	Audio Changeover Failure Alarm
--	--------------------------------

Audio Changeover Masked/Unmasked: Mask/Unmask the alarm of the Audio Changeover.

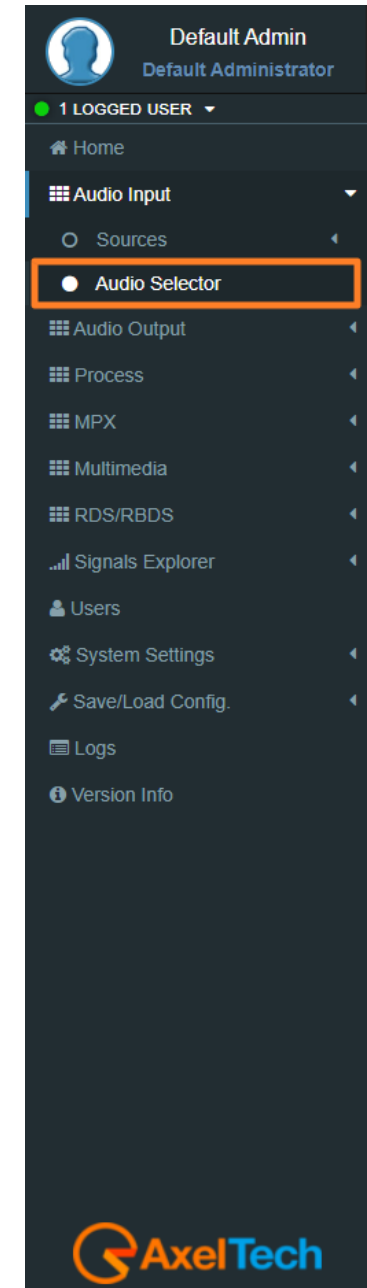

5.3 AUDIO OUTPUT

5.3.1 DIRECT SOURCE

from here can select one of the inputs (**Analog, Digital-1, Digital-2, Multimedia, External MPX and Tone Generator**) to go directly to the Stereo coder and **MPX+RDS**.

5.3.2 ANALOG

Manual changeover that allows you to choose the required source from four sources which are (**WIDE BAND PROCESSED, FM AUDIO PROCESSED, FM DELAYED PROCESSED and DIRECT SOURCE**).

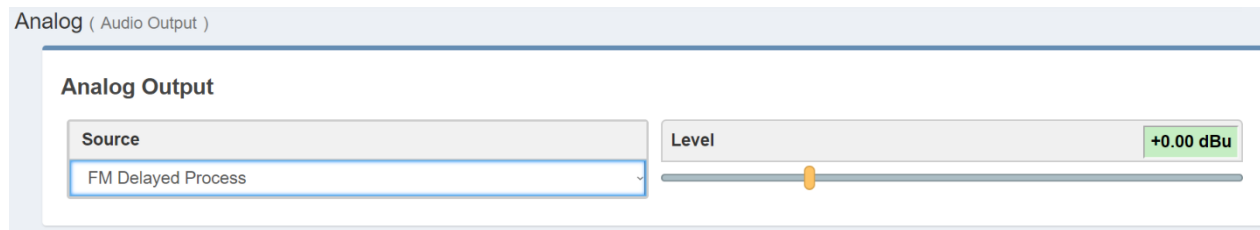

5.3.3 DIGITAL 1&2

Manual changeover that allows you to choose the required source from four sources which are (**WIDE BAND PROCESSED, FM AUDIO PROCESSED, FM DELAYED PROCESSED and DIRECT SOURCE**).

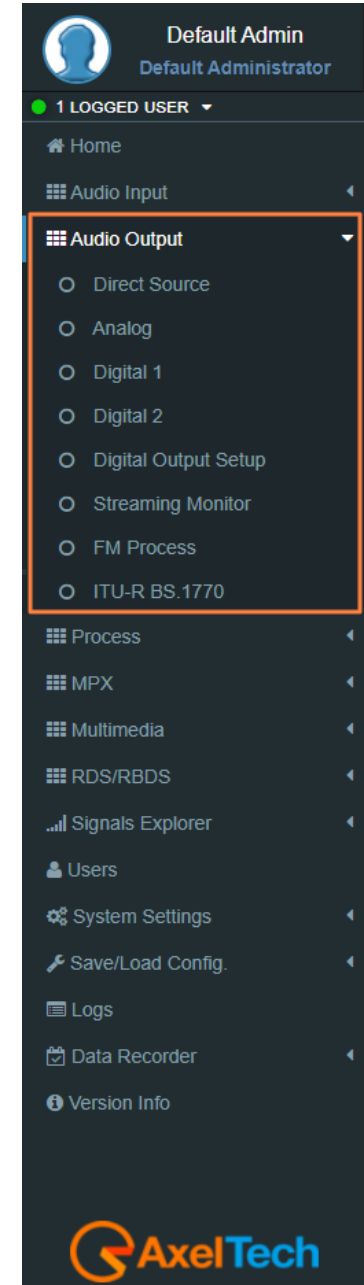
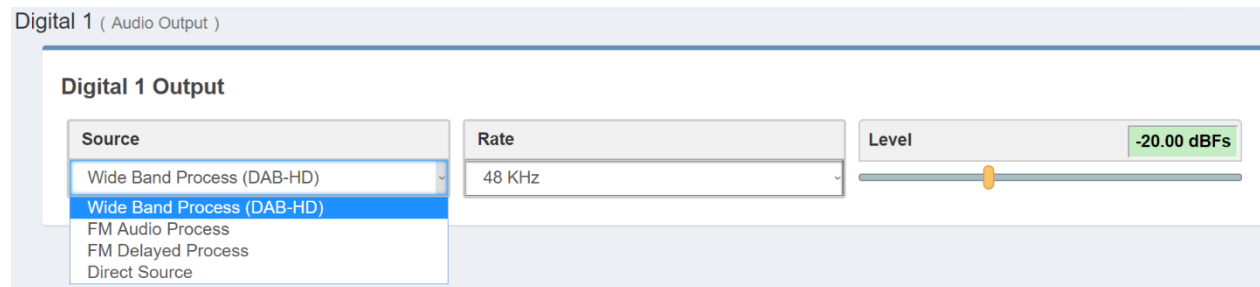

5.3.4 DIGITAL OUTPUT SETUP

Here can switch the **DIGITAL-1** between **AES/EBU-1** and **DANTE-1***.
 And switch the **DIGITAL-2** between **AES/EBU-2, MPX AUX3, DANTE-2***.

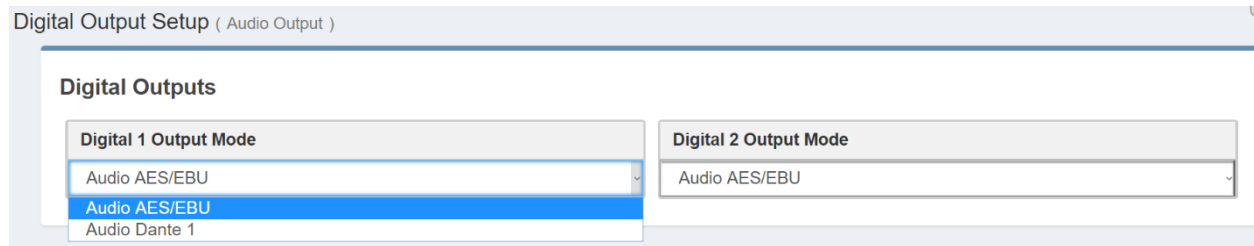

5.3.5 STREAMING MONITOR

Manual changeover that allows you to choose the source to listen to, or the send it oia internet (**VOIP**) to somewhere. It is possible to select between one of the following sources:
 (Analog, Digital 1, Digital 2, Audio Selector, Wide Process, MPX Decoder, Multimedia, Proces Compare).

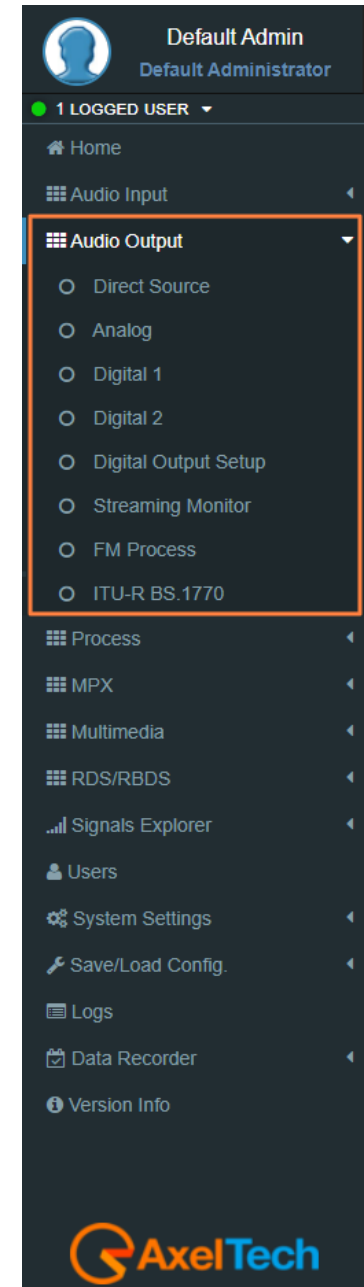
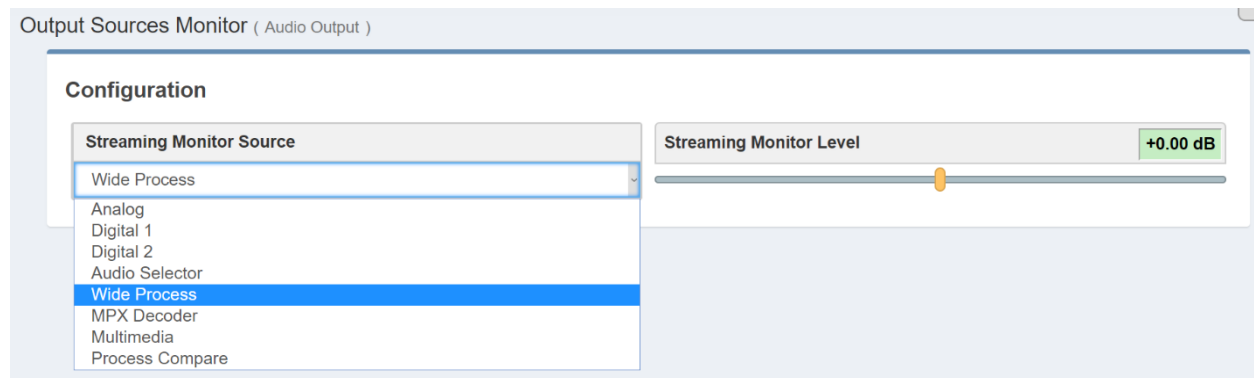

* Optional.

5.3.6 FM PROCESS

Here it can manage the **input PreEmphasis**, **output DeEmphasis**, and the **Delay**.

What are pre-emphasis and de-emphasis and what are they for?

In an FM system, noise has a random spectral distribution of a triangular type, with the result that noise occurs mainly at high frequencies within the bandwidth. This may be offset, to a limited extent, by increasing the high frequencies prior to transmission and reducing those quantities of high frequencies during reception. Consequently, reducing the high frequencies in the receiver also reduces the high frequency noise. These processes of enhancement prior to transmission and subsequent reduction of certain frequencies are known as **pre-emphasis** and **de-emphasis**.

The amount of **pre-emphasis** and **de-emphasis** needed is determined by the time constant of an **RC filter circuit**. In most parts of the world the time constant of **50µs** is used. In North America and South Korea, the time constant of **75µs** is used. This applies to both **MONO** transmissions and **STEREO** transmissions. In stereo signals, **pre-emphasis** is applied to the *left-hand* and *right-hand* channels prior to **MPX** multiplexing. The amount of **pre-emphasis** that can be applied is nevertheless limited by the fact that many forms of contemporary music contain more high-frequency energy than the musical styles that were fashionable at the time **FM** broadcasting was introduced, i.e., around the late 1950's. As a result, pre-emphasis cannot be used too much nowadays as it would cause an excessive shift of the **FM** carrier. The more modern FM broadcasting systems tend to use a variable pre-emphasis system which depends on the program and the audio material inputted into the audio processor.

In electronic audio signal processing, **pre-emphasis** refers to a process system designed to increase certain frequencies (usually the high frequencies) within a given bandwidth frequency with respect to the levels of other frequencies (usually the low frequencies). All this is done to improve the **S/N** (signal/noise) ratio, and consequently minimize the negative effects of phenomena, such as attenuation, distortion, or saturation, during processes or parts introduced after those already in the system. This whole system is called "**emphasis**". The frequency tripping curve is determined by special time constants and the cut frequency can be calculated using mathematical formulas. The reverse process, applied to **FM** receivers, is called **de-emphasis**.

One example which clearly illustrates the effects of pre-emphasis is the RIAA equalization curve on **33 rpm** and **45 rpm** vinyl records.

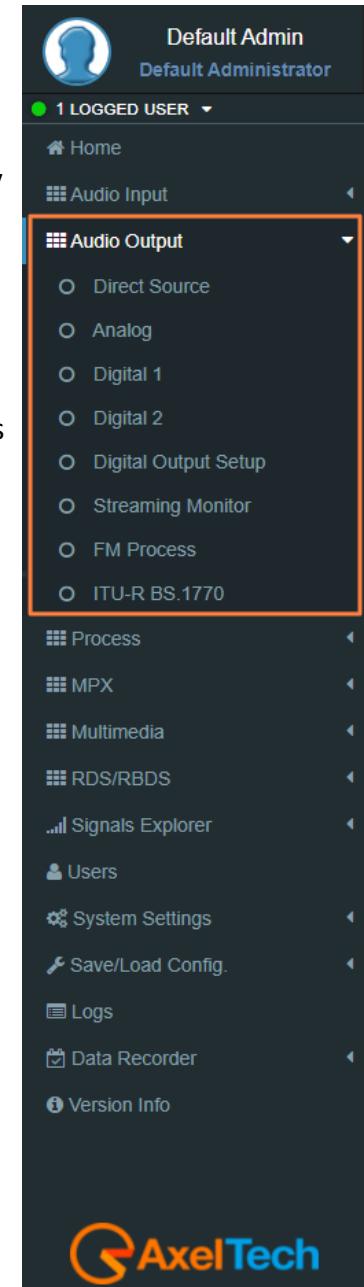
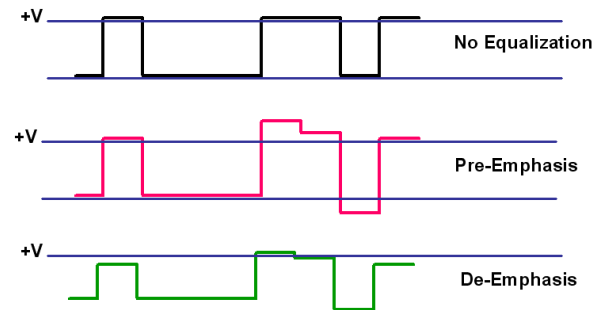

5.3.7 ITU-R BS.1770 (LOUDNESS NORMALIZATION)

it is an algorithms to measure audio programme **loudness** and **true-peak** audio level.

This measurement is one of the ways to measure and express the levels of trying to control the loudness of an audio recording. **dBTP** stands for decibel (**dB**) True Peak (**TP**). They are also used to measure the loudness in audio broadcast.

TU-R BS.1770 EBU R 128 compliance

ITU-R BS.1770 EBU R 128 compliance is achieved with those settings:

Threshold: **-23.0 dBFs (0 LU)**

Tolerance: **+0.5 dB**

Max True Peak: **-1.0 dBTP**

SOURCES

Threshold (0 LU)	-23.00 dBFs	Tolerance	+0.50 dB
Max True Peak	-1.00 dBTP	Long Integration Time	+45 sec
Max Short Term Loudness (LU)	+6 LU	Mode	Normal

Events

Audio Changeover Events

unmasked
 ▼ Audio Changeover Failure Alarm

TU-R BS.1770 LU Events: Mask/Unmask the Audio Output **ITU-R BS.1770 LU** Failure Alarm.

TU-R BS.1770 TP Events: Mask/Unmask the Audio Output **ITU-R BS.1770 TP** Failure Alarm.

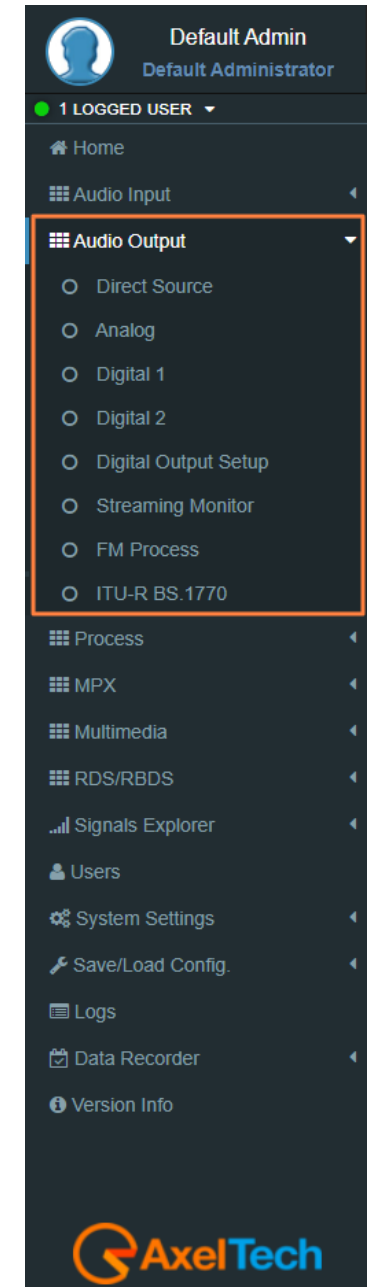

5.4 PROCESS

5.4.1 AUTOMATIC GAIN CONTROL – AGC

The audio volume could very annoying in the tune across the broadcast band in stations were it not for automatic gain control (**AGC**).

The **AGC** filter attempts to make the audio level constant, without causing noticeable changes in the sound. If sudden spikes are present, it can remove those spikes without lowering the output level too much, to avoid pumping and similar annoying effects. The **AGC** never increases the incoming audio level, it only decreases it if it gets too loud. Three different zones are defined for the AGC which are called attack zone, release zone and dead zone, shown in next figure.

- **Drive:** The AGC Drive adjusts the signal level to the slow dual-band AGC and this determines the amount of reduced gain in the AGC.
- **Attack:** one of these parameters which control the behavior (function) of the **AGC**. The attack time is the time that we control between two attack events. The **AGC's attack zone** is set to be above **0.8** (relative to the supply voltage) and below **-0.8**. If the output of the **VGA** (Variable Gain Amplifier) is within the attack zone the gain is reduced by one gain step for an attack time
- **Release:** the release time is the time that we control between two release events. The **AGC's release zone** is set to be between **0.6** to **-0.6** and the zone between the attack and release zones is called dead zone which basically no attack or release happens in this zone.
- **Gate Threshold:** control the limit of the lowest input level will recognize as a program. lower levels are considered as noise or background sounds and rise the AGC to the gate, effectively freezing gain to prevent noise breathing.

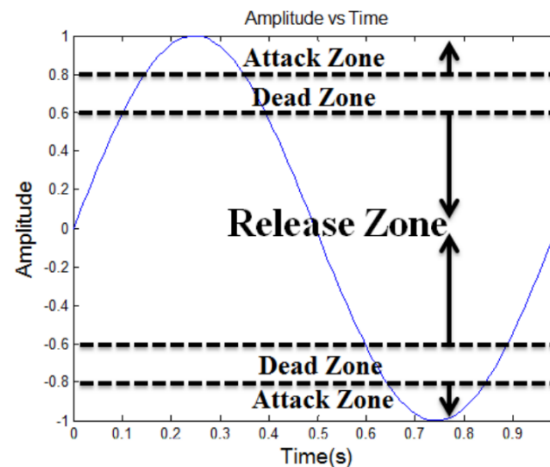
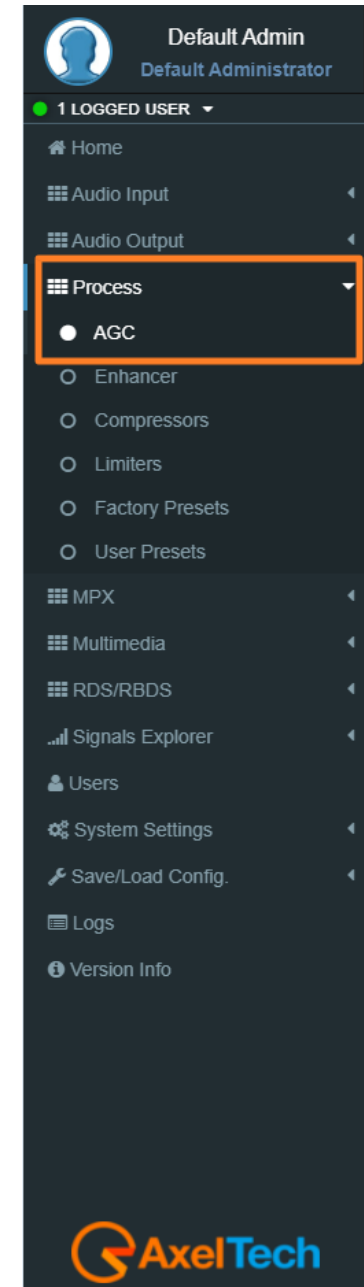
The screenshot shows the software interface for a user named "Default Admin". The "Process" menu is open, and the "AGC" option is selected and highlighted with an orange border. Other options in the menu include Enhancer, Compressors, Limiters, Factory Presets, User Presets, MPX, Multimedia, RDS/RBDS, Signals Explorer, Users, System Settings, Save/Load Config., Logs, and Version Info.

5.4.2 ENHANCER

Using the **Stereo Enhancer** you can increase the spatial image of stereo sound. Listeners will notice greater loudness, brilliance, and clarity of sound, as well as a more dynamic effect and greater depth of the sound. The accuracy of the integrated DSP in this device prevents the introduction of harmonic distortion and an unnatural sound source footprint. To enhance the stereo effect of an audio recording of a radio or television broadcast, this device has a **built-in Stereo Enhancer** that creates an effect similar to a broad separation of the left-hand and right-hand channels. This effect is obtained by adding a part of the other channel to each channel, but in antiphase. BY modifying the **L-R** and **L+R** ratio in this way, a sound with a greater stereophonic impact is obtained, creating an extremely strong **psycho-acoustic** effect, in particular on the audio details.

Mode: functions are used to **enable/disable** Stereo Enhancer.

Band: This is the frequency range within which the Stereo Enhancer process is applied. Available options include (**MID-HIGH, WIDE**).

Effect Limiter: This feature introduces a stereo limiter to the stereo enhancer process, with operation settable at three levels (**LOW, NORMAL, HIGH**).

Effect Drive: This parameter can be used to set the level of the effect at the audio processor output once the Stereo Enhancer has processed the audio material. The possible values range from **1** to **10**.

Effect Depth: The depth control can be used to control the **Digital Delay** introduced in the **L-R** and **L+R** ratio.

Pre-Process Equalizer

The **Pre-Process Equalizer** is a feature that allows you to introduce an equalizer with free curves that can be customised to suit your own taste, and fit it in before the multiband processor unit. The effect introduced by this feature is extremely clear as regards the vocal frequency spectrum, or specific presets with low compression levels. Where presets with high compression levels are concerned, the multiband unit located after the **pre-equalizer** tends to cancel out the effects.

Speech Detector

The speech detector function is a key operating parameter for the audio processor. It allows you to detect when spoken material is applied to the audio processor input. Speech recognition is essential to be able to switch off audio processes where voices inputted may change significantly in terms of timbre, colour and footprint. We recommend you always leave this control on.

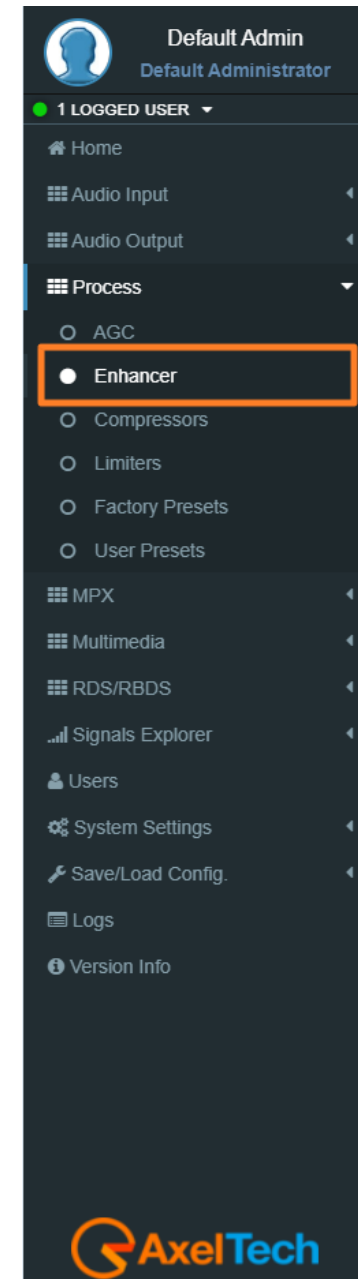

5.4.3 COMPRESSORS

In the Multiband control page, you can define the amount of compression **Threshold** to apply to each bandwidth, ranging from a minimum of **- 12.0 dB** to a maximum of **+ 8.0 dB**. Using this control, you can set the threshold at which the compressor must react. A **Threshold** setting of **0 dB** (extreme high) means that the compressor only works when the level of that bandwidth reaches of **0 dB**. Conversely, a setting of **-9.0 dB** (extreme low) means that the compressor starts to work when the audio level within that bandwidth reaches at least **-9.0 dB**. Clearly, with a setting of around **0 dB**, the compressor tends to work very little and therefore maintains the original quality of the audio material inputted into the processor. Values closer to **-9 dB**, meanwhile, tend to keep the compressor working constantly and therefore, as the dynamics are reduced, the audio inputted into the audio processor will generally be processed (with values between **-6.0 dB** and **+6.0 dB**).

Multiband Proc. Type:

This control shows process behaviour of this device. Various controls are grouped together under a few simple use conditions. The controls grouped together in these four functions are conventional preset controls for a multiband compressor, i.e. **Attack, Release, and Threshold Gate**. The action and compression modes are (**Protective, Soft, Normal, Aggressive-1.....5, Extreme**) .

PROTECTIVE is a limited type of compression, which tends to maintain a natural sound. In the **NORMAL** mode, the compression parameters applied to the audio sent to the processor are slightly emphasized and the compression ratio is increased, while a balance is maintained between the audio details of the material inputted and the compression applied. The conditions for **AGGRESSIVE** and **EXTREME**, meanwhile, are different, as strong compression ratios are entered for the **AGGRESSIVE** mode and even stronger ones are used for the **EXTREME** mode, creating a typically ‘pumped up’ sound. Generally speaking, the Multiband Process Aggressive and Extreme modes are designed to emphasize audio material that already has little musical detail. This could be continuous musical content, such as heavy metal or hard rock, or particularly complex audio material.

Multiband Coupling:

The bandwidth coupling control can limit the ability of the bandwidths to work too independently, thereby destroying the spectral balance of the original audio material inputted in the processor. The options available are (**LOW, MID, HIGH**) where **Low** means a low coupling between the bandwidths, so that they can work as independent as possible, while **HIGH** tends to make the bandwidths work together as much as possible. **MID** mode offers a good compromise to enable greater **re-equalization** for a more coherent tonal balance.

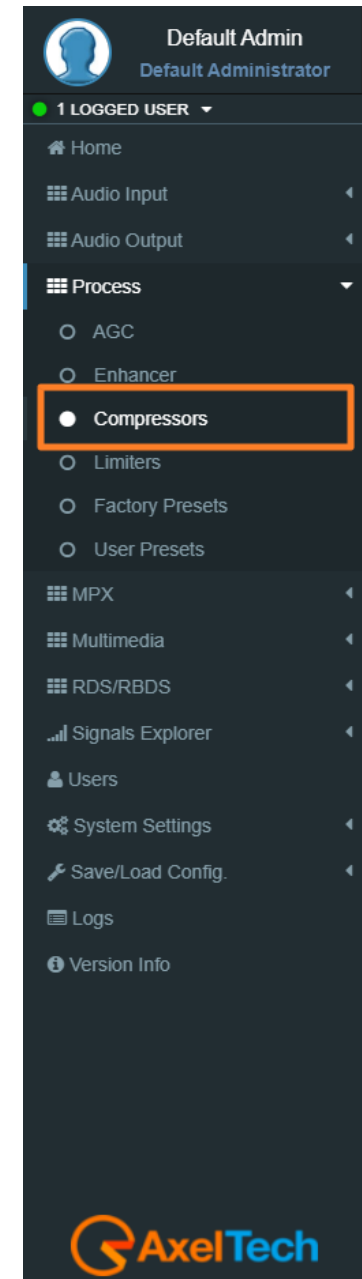

5.4.4 LIMITERS

Final Limiter Bass Drive

The Final Drive Bass Limiter is exactly the same control as the **Final Limiter Main Drive**, but applies to all the bass frequencies, i.e. those between **5/30 Hz** and **350 Hz**.

Final Limiter Main Drive

The Final Limiter Main Drive is the last stage before the **MPX stereo encoder**, right between the **Final Expander** and the **Power Limiter**. This control allows you to increase or decrease the substance of the audio material delivered to the **MPX encoder**. The term **MAIN** refers to the fact that it operates on the **350 Hz to 15 kHz** frequency range.

Warning: as already mentioned, it is a very important and powerful command, and so overuse of the **Final Limiter Main Drive** tends to overwork the "**HF**", i.e. the Main Final Limiter.

The Lookahead Limiter

The Lookahead Limiter is a predictive limiter that works on the final stage of the audio processor. Predictive means the processor's ability to know what and how much audio material will be inputted into the processor for processing and outputting and then exactly the desired level of signal. While it is impossible to predict the future, it is possible to add a small delay (an increase about **6-8ms** in the overall delay) in the audio process stage, in order to change the level and the waveform outputted by the processor in the event of strong variations in the input signal.

SuperBass

The SuperBass parameter acts directly on the compression of low frequencies below **100 Hz**. The maximum compression available is **15 dB**. Operation of this control is very simple, but it is very powerful because it can influence the sound of **low frequencies** considerably. This **SuperBass** works on the principle that if you cannot increase a parameter as it has already reached the highest clipping levels, then to be able to bring it out further, it is advisable to reduce other parameters in order to emphasise and increase the higher bandwidth selected and, in that case, the **low frequencies**.

Following this principle and reducing the frequencies between **150 Hz** and **300 Hz** at the same time, the Superbass frequencies tend to emerge. Very high Superbass levels can cause strong compressor movements in Bandwidth 1. This is absolutely normal, unless the limiter does not reach the **red** area. This condition indicates the need to limit use of this control because the processor is not operating in the linear region.

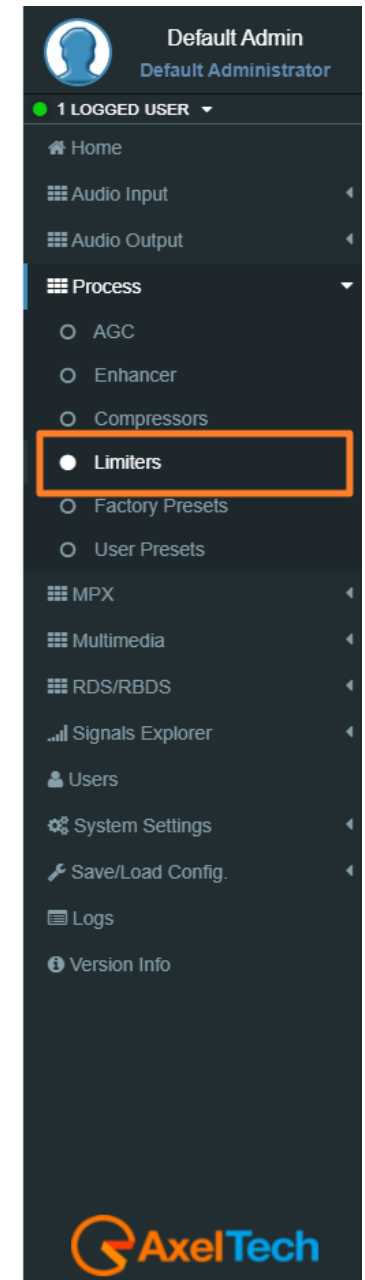

Expander

The multiband expander is used to reduce the background noise on vocal audio signals or a microphone, or to reduce unwanted effects caused by the introduction of strong compressions. The allowed and available values range from **Disable** to **+5**. To ensure the adjustments are performed properly, we recommend you listen to the voices without music, or keep the background music low. Levels above **3** tend to clean the voice, however, they also tend to decrease the brilliance of the sound under certain operating conditions. This command uses the same expansion process as the **Lookahead Limiter** and therefore it does not add any delay.

HF: High Frequency Limiter is the stage that occurs on the amount of emphasis applied to the original signal. If this control is set too high, or works in the red area indicates that the preset you are using was created evil, and there is an excess of compression or working on high frequencies.

BF: Final Bass Limiter, this limiter works on Bass, If this control is set too high, or works in the red area indicates that the preset you are using was created evil, and there is an excess of compression or work on the frequencies high.

MF: Main Frequency Limiter, this whole band limiter intervenes between **350Hz** and **15kHz**. The action of this control can be strongly influenced by the Final Limiter Drive control. If this control is set too high, or works in the red area indicates that the preset you are using was created evil, and there is an excess of compression or working on high frequencies.

LA: Look Ahead Limiter Limiter intervention. If this control is set too high, or works in the red area indicates that the preset you are using was created evil, and there is an excess of compression or working on high frequencies.

PA: Power Attenuator, when the Power Control ITU-R BS.412 is activated, this control indicates to what intervenes the Power Control. If this control is set too high, or works in the red area indicates that the preset you are using was created evil, and there is an excess of compression or working in the high frequency.

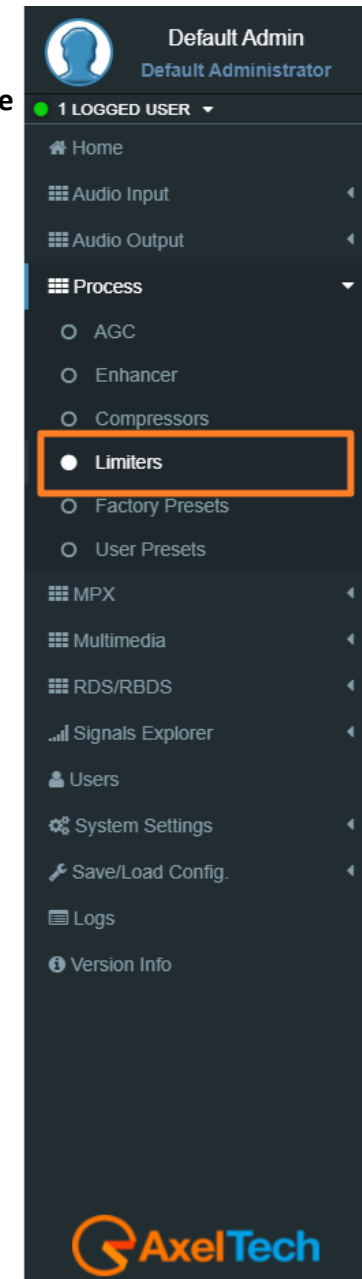

5.1 MPX (NOT IN FALCON D7)

5.1.1 INTERNAL MPX ENCODER

CONFIGURATION

Configuration		
Preemphasis 50uSec	LimiterMode Pshychoacoustic	LimiterDrive +0.30 dB
Psychoacoustic Mask General Purpose	Audio Power Limiter (MPX1) Off	Post Audio Limiter Gain +0.00 dB

Preemphasis: Technical parameter. Could be **Off, 50 μ Sec, 75 μ Sec.**

LimiterMode: Off, Normal, Look-Ahead, Pshychoacoustic. If LimiterMode is on you can set

LimiterDrive: off or from +0.10dB to +1.60dB.

Psychoacoustic Mask: Set it on **General Purpose** or **Dance**.

Audio Power Limiter (MPX1): Here you can set for a special limiter that complies with the ITU-BS412 legislation. Use it only when you have the needs described by the legislation.

Post Audio Limiter Gain: form -12dB to +12dB.

SETUP

Setup		
Pilot Level -21.00 dBr	Mpx Mode Stereo	Internal Mpx Final Gain +0.00 dB

Pilot Level: Select here the Pilot level.

Mode: Select here the Mode.

Internal Mpx Final Gain: form -12dB to +12dB.

Default Admin
Default Administrator

1 LOGGED USER

- Home
- Audio Input
- Audio Output
- Process
- MPX**
 - Internal MPX Encoder**
 - Changeover
 - Inputs
 - Outputs
 - MPX Analysis
- Multimedia
- RDS/RBDS
- Signals Explorer
- Users
- System Settings
- Save/Load Config.
- Logs
- Version Info

5.1.2 CHANGEOVER

5.1.2.1 DELAY / Mode

CONFIGURATION

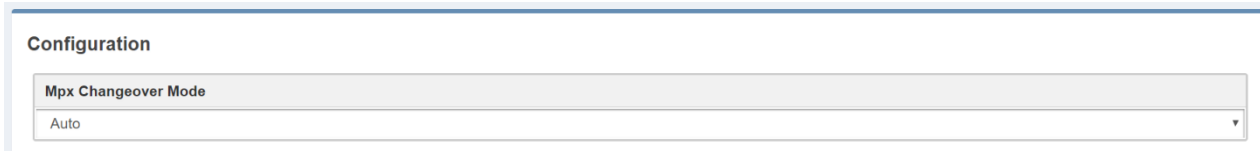

Mpx Changeover Mode: *Auto* – The source is chosen automatically.

Source A – The source is forced manually on Source A.

Source B – The source is forced manually on Source B.

Mpx Delay: Select here the delay time (ms) to apply on the MPX.

Mpx Delay Mode: Select here if you want the delay **Off**, **OnSourceA**, **OnSourceB**, **OnOutput**.

Events

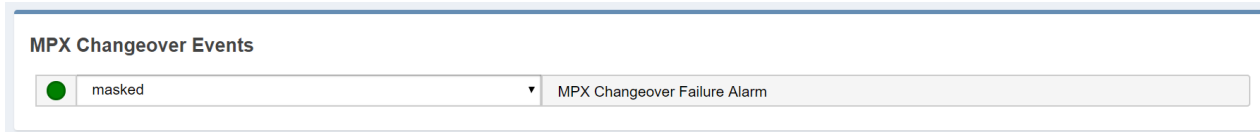

MPX Changeover Masked/Unmasked: Mask/Unmask the alarm of the MPX Changeover.

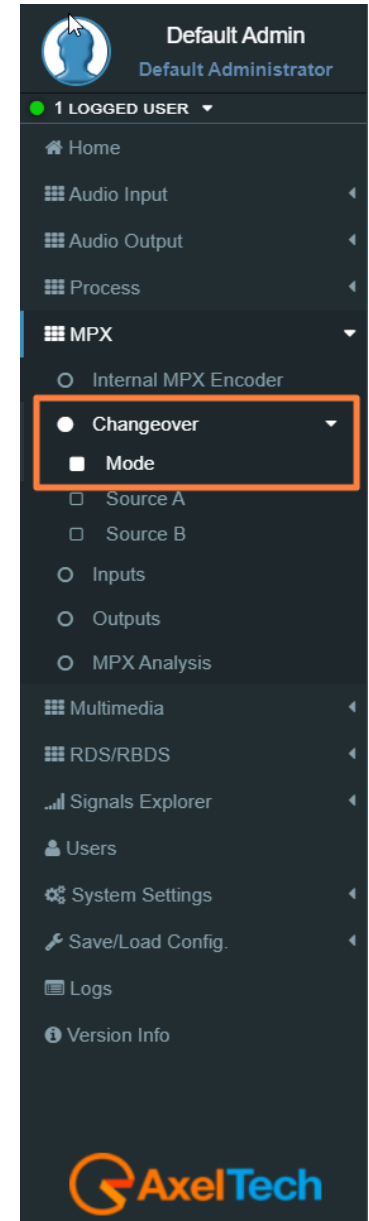
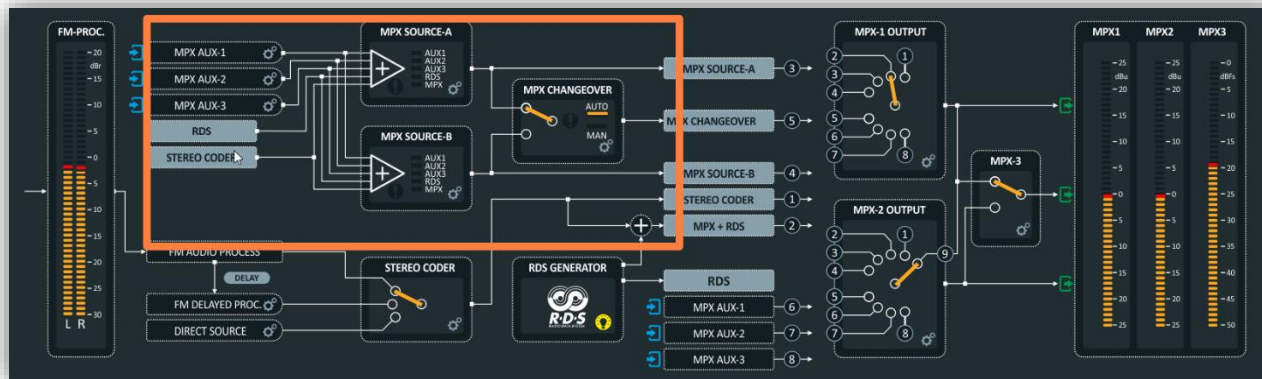

As shown in the previous picture the **MPX Changeover** can select between two different sources: **SourceA** or **SourceB**. In this section, you can define parameters related to **Source A** and all its components like (**Mpx**, **Aux1**, **Aux2**, **RDS**, **Filters**).

5.1.2.2 SOURCE A

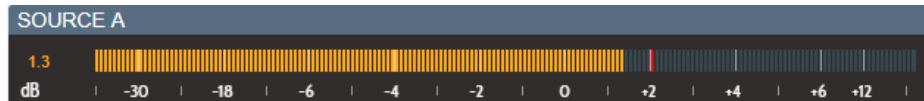

MPX MIXER

MPX Mixer

Internal Mpx Mix <input type="checkbox"/> Off <input type="range"/>	Internal RDS Mix Off
External Aux1 Mix <input type="checkbox"/> Off <input type="range"/>	External Aux1 Mode Full band
External Aux2 Mix <input type="checkbox"/> Off <input type="range"/>	External Aux3 Mix <input type="checkbox"/> Off
Reference Label <input type="text"/>	

Internal Mpx Mix: Select here the **Mpx** Mix level (dB).

Internal RDS Mix: Select here if you want the RDS or not.

External Aux1 Mix: Select here the level of **Aux1**.

External Aux1 Mode: Select here the **Aux1** filter. **Full Band** or **RDS Filtered**.

External Aux2 Mix: Select here the level of **Aux2**.

Reference Label: In this parameter, you can assign the source name.

MPX SOURCE A RDS REBROADCASTING

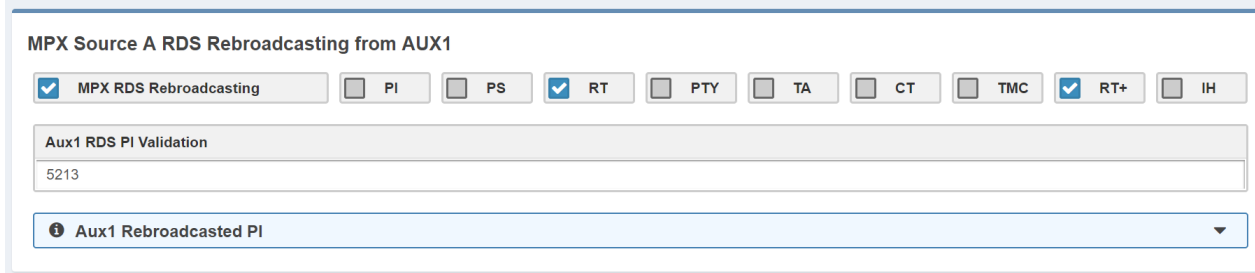

From this section, you can select which RDS services of the Aux1 signal you want to rebroadcast.

- From MPX Mixer section (previous section)
- > turn on the **Internal RDS Mix**
- > and in **External Aux1 Mode** selects **RDS Filtered**.

Here enable **MPX RDS Rebroadcasting** and select all the desired services from Aux1.

For example: if you select **PS** from here, you will rebroadcast the PS of Aux1 and not the PS of the Internal RDS.

Attention: The **AF** is always chosen from the Internal RDS and not from Aux1.

Aux1 Rebroadcasted PI:

A valid **RDS** services rebroadcast source will be available only if **Aux1** decoded **PI** will match with the above set **Aux1 RDS PI Validation** value.

Note: A value=0 will bypass this check.

MPX SOURCE A Changeover Reference Dataset

It is can specify if and which **Dataset** to use as a reference when the **Changeover Mpx** changes to source. We can also decide if the Extended **Dataset** is controlled by the **MPX Changeover**. That is mean the possibility to change dataset depending on the Audio Source. Change a **DataSet** it's possible from **GPI**, **Software**, **UECP** but it's also possible by Audio Source. In case of Fault of MAIN Audio (**Analog**, **Digital** or **MPX**) when the device change Audio Input could automatically change DataSet. This function is already known as "**DataSet Chane on Changeover**".

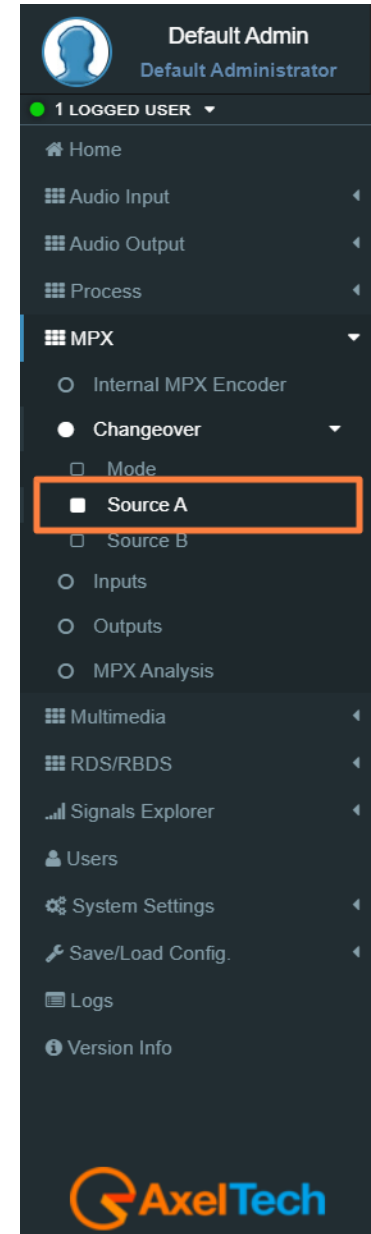

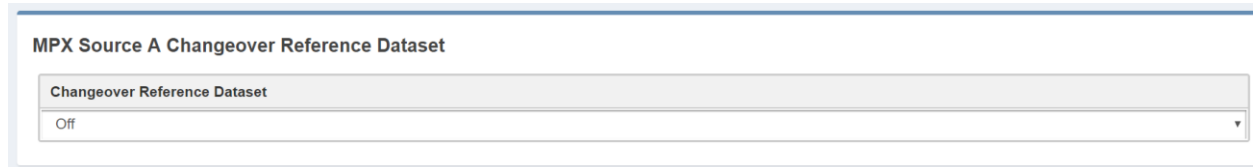

This is useful for example when we are rebroadcasting one or more **RDS** services on Source A and for some reason, the **Changeover MPX** passes on **Source B**. In this way we can check the contents of the services that interest us.

MPX SOURCE A VALIDATION

From this section, you decide all the parameters related to the validation of the **SourceA** MPX Signal. Some of these parameters are indicated on the Home Page top mask in the section **MPX-SOURCES CHANGEOVER, A SRC.**

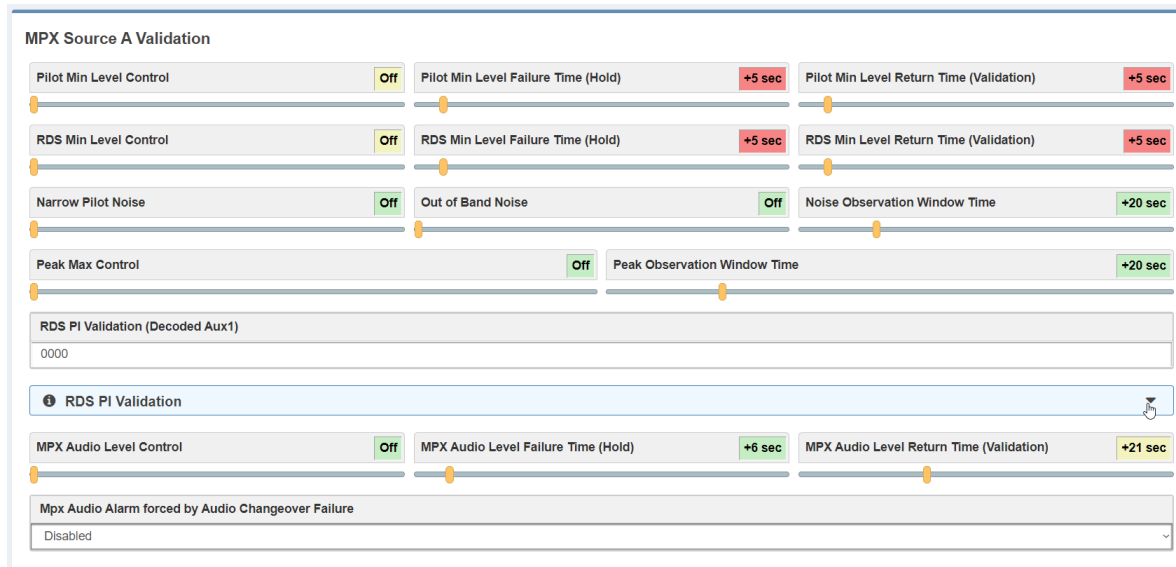

Pilot Min Level Control: if the Mpx pilot is under the threshold selected here the signal is not valid.

RDS Min Level Control: if the RDS level is under the threshold selected here the signal is not valid.

Peak Max Control: If the peak of the MPX level is higher then this value the signal is not valid.

Audio Level Control: If the Audio Level is under the threshold selected here the signal is not valid.

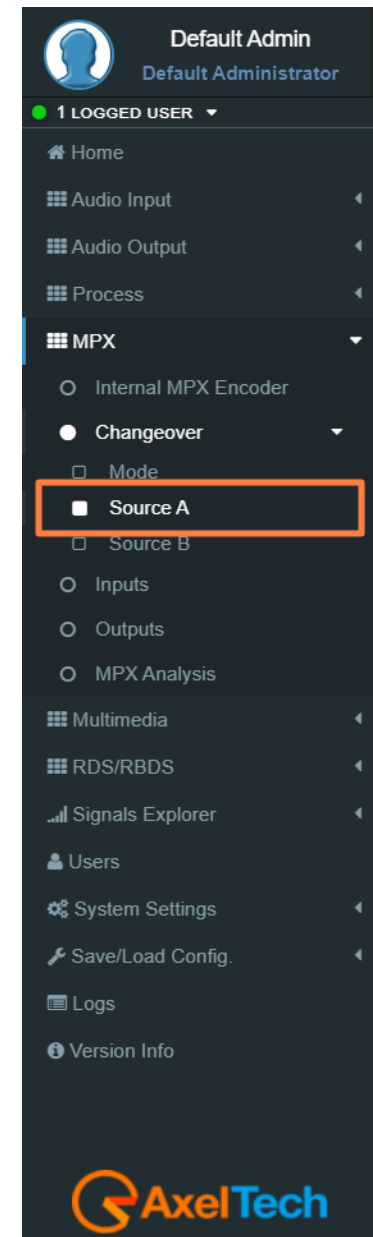

Out of Band Noise: If the Noise level is higher then this value the signal is not valid. (Out of Band Noise > 60 kHz).

Narrow Pilot Noise: If the Noise level is higher then this value the signal is not valid. (15 kHz < Narrow Pilot Noise < 23 kHz)

RDS PI Validation: If the PI is 0000 the RDS PI Validation is disabled. In the other cases, the signal is valid only if SourceA PI = RDS PI Validation.

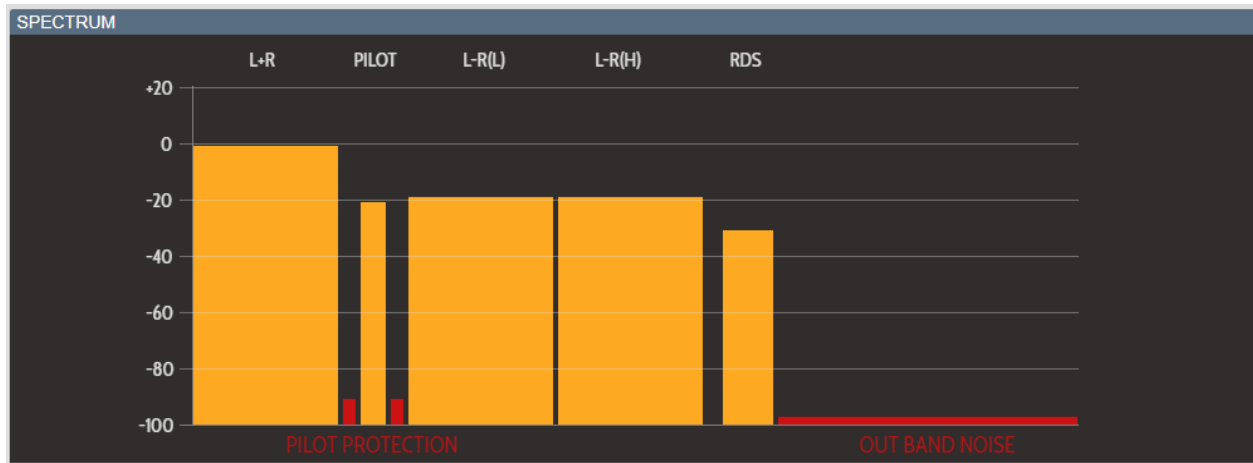

In red the noise
 Pilot protection = Narrow Pilot Noise
 Out Band Noise = Out of Band Noise

Events

MPX Source A Events

masked MPX Source A Alarm

MPX Source A Masked/Unmasked: Mask/Unmask the alarm of the MPX Source A.

The screenshot shows the software interface for 'Default Admin'. The 'MPX' menu is expanded, showing options: Internal MPX Encoder, Changeover, Mode, Source A (highlighted with a red box), and Source B. Other menu items include Home, Audio Input, Audio Output, Process, Multimedia, RDS/RBDS, Signals Explorer, Users, System Settings, Save/Load Config., Logs, and Version Info.

5.1.2.3 SOURCE B

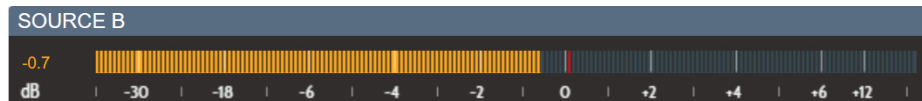

MPX MIXER

Internal Mpx Mix: Select here the Mpx Mix level (dB).

Internal RDS Mix: Select here if you want the RDS or not.

External Aux1 Mix: Select here the level of Aux1.

External Aux1 Mode: Select here the Aux1 filter. **Full Band** or **Rds Filtered**.

External Aux2 Mix: Select here the level of Aux2.

Reference Label: In this parameter, you can assign the source name.

MPX SOURCE B RDS REBROADCASTING

From this section, you can select which RDS services of the Aux1 signal you want to rebroadcast. From MPX Mixer section (previous section) turn on the **Internal RDS Mix** and in **External Aux1 Mode** select **RDS Filtered**. Here enable **MPX RDS Rebroadcasting** and select all the desired services from AUX1. For example: if you select PS from here, you will rebroadcast the PS of Aux1 and not the PS of the Internal RDS.

Attention: The AF is always chosen from the Internal Rds and not from Aux1.

MPX SOURCE B VALIDATION

From this section, you decide all the parameters related to the validation of the **SourceB** MPX Signal. Some of these parameters are indicated on the Home Page top mask in the section **MPX-SOURCES CHANGEOVER, B SRC.**

Pilot Min Level Control: if the MPX pilot is under the threshold selected here the signal is not valid.

RDS Min Level Control: if the RDS level is under the threshold selected here the signal is not valid.

Peak Max Control: If the peak of the MPX level is higher then this value the signal is not valid.

Audio Level Control: If the Audio Level is under the threshold selected here the signal is not valid.

Out of Band Noise: If the Noise level is higher then this value the signal is not valid. (Out of Band Noise > 60 kHz).

Narrow Pilot Noise: If the Noise level is higher then this value the signal is not valid. (15 kHz< Narrow Pilot Noise < 23 kHz).

RDS PI Validation: If the PI is 0000 the RDS PI Validation is disabled. If the other cases the signal is valid only if **SourceB PI** = RDS PI Validation.

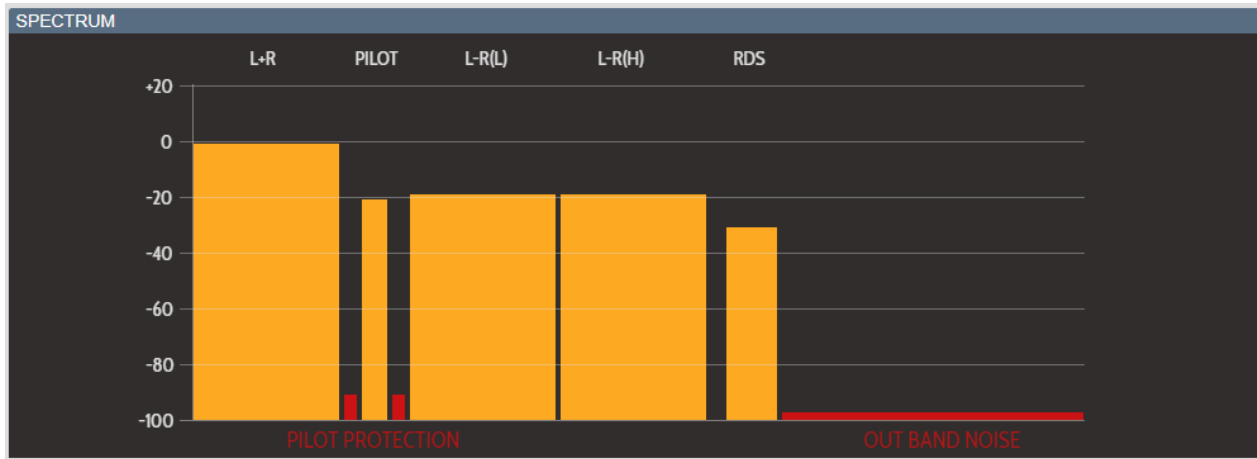

In red the noise
 Pilot protection = Narrow Pilot Noise
 Out Band Noise = Out of Band Noise

Events

MPX Source B Events

masked
 MPX Source B Alarm

MPX Source B Masked/Unmasked: Mask/Unmask the alarm of the MPX Source B.

Default Admin
Default Administrator

1 LOGGED USER ▾

- Home
- Audio Input
- Audio Output
- Process
- MPX** ▾
 - Internal MPX Encoder
 - Changeover** ▾
 - Mode
 - Source A
 - Source B**
 - Inputs
 - Outputs
 - MPX Analysis
- Multimedia
- RDS/RBDS
- Signals Explorer
- Users
- System Settings
- Save/Load Config.
- Logs
- Version Info

5.1.3 OUTPUTS

MPX OUTPUT 1

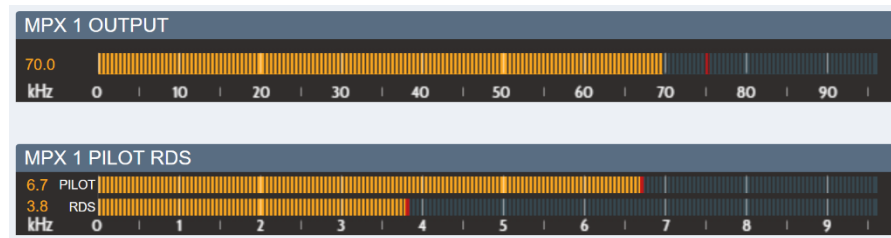

Mpx Output 1

Source Internal MPX Encoder + RDS	Level +0.00 dB	Clipping Level +5 dBu
--------------------------------------	-------------------	--------------------------

Source: Select here the source for the **MPX OUT-1**.

Select here between (Internal MPX Encoder, Internal MPX Encoder + RDS, Source A, Source B, Changeover, Aux 1 or Aux 2).

Gain: Set here the gain of the MPX signal.

Clipping Level: If you work with values < 2 dB, set this parameter at **+5 dBu**. If you work with values > 2 dB, set this parameter at **+18 dBu**.

Default Admin
Default Administrator

2 LOGGED USERS

- Home
- Audio Input
- Audio Output
- Process
- MPX
 - Internal MPX Encoder
 - Changeover
 - Inputs
 - Outputs
 - MPX Analysis
- Multimedia
- RDS/RBDS
- Signals Explorer
- Users
- System Settings
- Save/Load Config.
- Logs
- Version Info

MPX OUTPUT 2

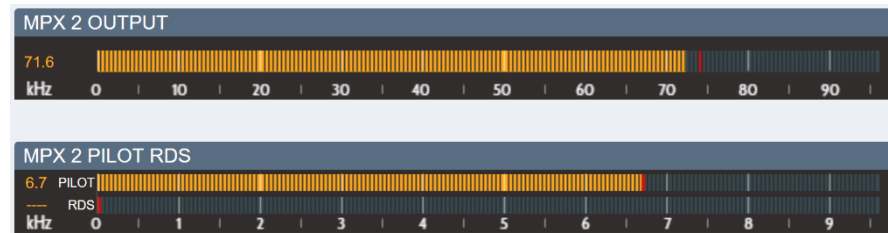

Mpx Output 2

Source Internal MPX Encoder	Gain +0.00 dB	Clipping Level +5 dBu
--------------------------------	------------------	--------------------------

Source: Select here the source for the **MPX OT-2**.

Select here between: Internal MPX Encoder, Internal MPX Encoder + RDS, Source A, Source B, Changeover, Aux 1, Aux 2, Mpx1 Output.

Gain: Set here the gain of the MPX signal.

Clipping Level: If you work with values < 2 dB, set this parameter at **+5 dBu**. If you work with values > 2 dB, set this parameter at **+18 dBu**.

Mpx Inputs

Mpx Inputs

Aux1 Sensitivity +0.00 dBu	Aux2 Sensitivity +0.00 dBu
-------------------------------	-------------------------------

Mpx Outputs Timed Test

Mpx Outputs Timed Test

Test Mode Muted	Test on Mpx1	Test on Mpx2
--------------------	--------------	--------------

Default Admin
Default Administrator

2 LOGGED USERS ▾

- Home
- Audio Input
- Audio Output
- Process
- MPX** ▾
 - Internal MPX Encoder
 - Changeover
 - Inputs
 - Outputs**
 - MPX Analysis
- Multimedia
- RDS/RBDS
- Signals Explorer
- Users
- System Settings
- Save/Load Config.
- Logs
- Version Info

Here you can test the output signal of **MPX1** or **MPX1** by choosing one of the test modes and select the MPX that you want to test it.

Test Mode: Muted, Pilot (-21dBr), 100Hz (0.0dBr), 400Hz (0.0dBr), 1kHz (0.0dBr), 5kHz (0.0dBr), 10kHz (0.0dBr), 13kHz (0.0dBr), 15kHz (0.0dBr).

5.1.4 MPX ANALYSIS

This spectrum shows you the levels of the MPX components.



The screenshot shows the software interface with the following elements:

- User:** Default Admin (Default Administrator)
- Logged User:** 1 LOGGED USER
- Navigation Menu:** Home, Audio Input, Audio Output, Process, MPX, Multimedia, RDS/RBDS, Signals Explorer, Users, System Settings, Save/Load Config., Logs, Version Info.
- MPX Sub-menu:** Internal MPX Encoder, Changeover, Inputs, Outputs, **MPX Analysis** (highlighted with a red box), Multimedia, RDS/RBDS, Signals Explorer, Users, System Settings, Save/Load Config., Logs, Version Info.

RDS: RDS level

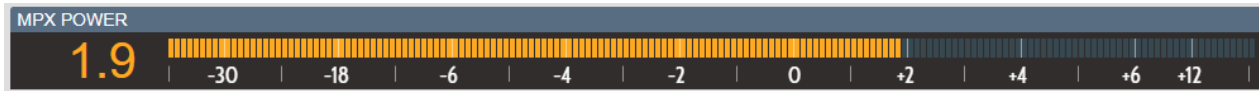

MPX POWER: ITU-R BS412 measure, average power measured over 60 seconds

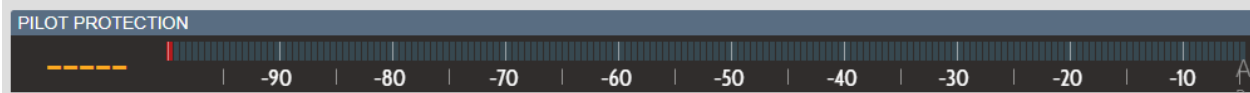

PILOT PROTECTION: Pilot protection level

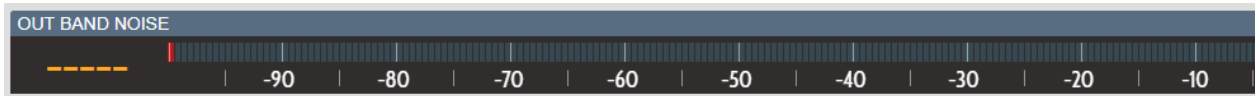

OUT BAND NOISE: Out Band Noise level.

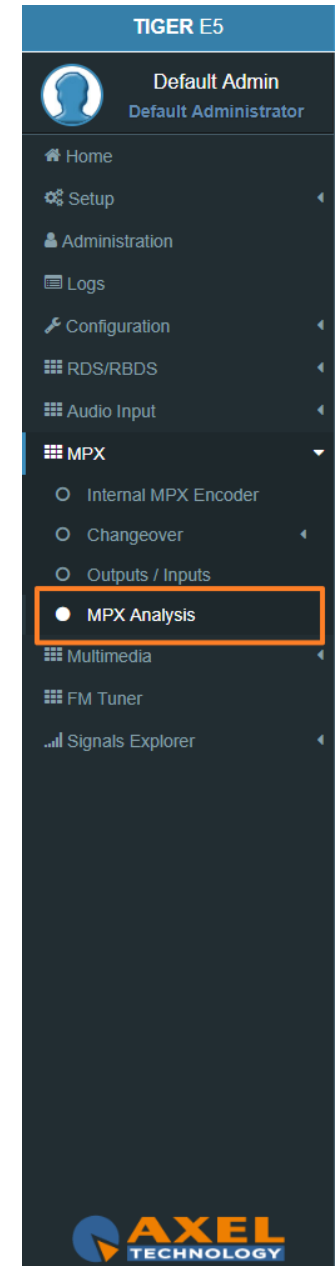

5.2 MULTIMEDIA

5.2.1 SOURCES

5.2.1.1 STREAM 1 DECODER, STREAM 2 DECODER

STATUS (The status parameters are only readable)

Status	Protocol	Encoder	BitRate	Mode	Freq
Connected	Icecast	MPEG-1 Layer 3 (MP3)	128kBits	Stereo	44.1 KHz

Status: Decoder Status

Protocol: Transport protocol

Encoder: Format of the decoded signal

BitRate: BitRate – the bits conveyed or processed per unit of time

Mode: Stereo or Mono

Freq: Sampling rate

CONFIGURATION

Configuration		
Mode IcecastReceiver	Buffer (ms) 3000	
Multicast RX Enable Enabled	Multicast Host Group 239.10.1.2	Output Gain (dB) 0.0

Mode: Select here the Protocol of the Transport and the format of the decoded signal.

Buffer (ms): Set here the desired buffer delay (ms).

Multicast RX Enable: Enable/Disable the Multicast receiving.

Multicast Host Group: Set here the IP of the Multicast Group.

Output Gain: Set here the Output Gain.

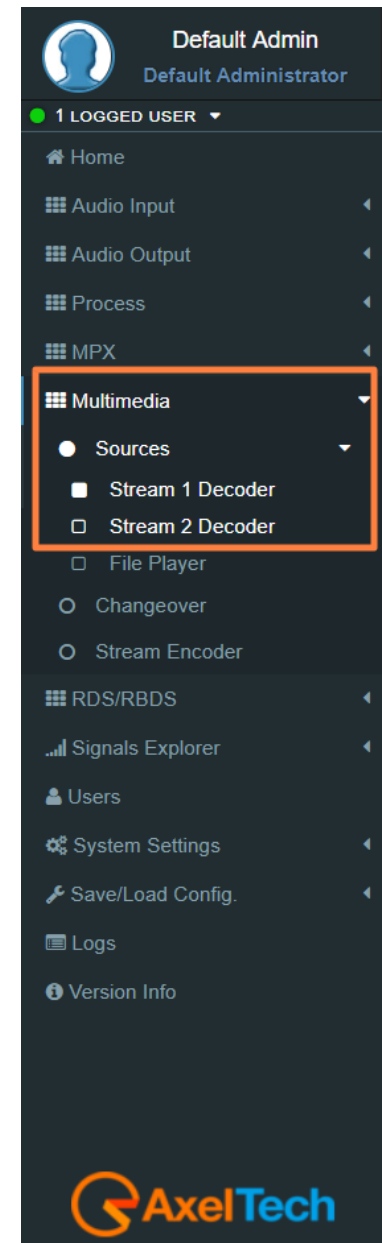

TRANSPORT MODE

RTP

Port
10000

Port: Here you can set the Port of your RTP encoder.

UDP

Port
10000

Port: Here you can set the Port of your UDP encoder.

ICECAST

Location
http://icestreaming.rai.it/2.mp3

Location: Here you can type the URL of the stream to receive your audio from your Icecast.

CODEC SETTINGS

RAW 16 BIT

Mode
Stereo

Sample Rate
32 kHz

Mode: Select here the Mode of the RAW 16 BIT audio decoded.

Sample Rate: Select here the Sample Rate of the RAW 16 BIT audio decoded.

The screenshot shows the Default Admin interface. At the top, it says "Default Admin" and "Default Administrator". Below that, it indicates "1 LOGGED USER". The main menu includes: Home, Audio Input, Audio Output, Process, MPX, Multimedia (highlighted with an orange box), Sources, Stream 1 Decoder, Stream 2 Decoder, File Player, Changeover, Stream Encoder, RDS/RBDS, Signals Explorer, Users, System Settings, Save/Load Config., Logs, and Version Info. The AxelTech logo is at the bottom.

MP3

Mode
Stereo ▼

Sample Rate
32 kHz ▼

Mode: Select here the Mode of the MP3 audio decoded.

Sample Rate: Select here the Sample Rate of the MP3 audio decoded.

OPUS

Mode
Stereo ▼

Sample Rate
48 kHz ▼

Mode: Select here the Mode of the OPUS audio decoded.

Sample Rate: Select here the Sample Rate of the OPUS audio decoded.

AAC

Mode
Stereo ▼

Sample Rate
44.1 kHz ▼

Mode: Select here the Mode of the AAC audio decoded.

Sample Rate: Select here the Sample Rate of the AAC audio decoded.

The screenshot shows the 'Default Admin' interface with the 'Multimedia' menu expanded. The menu items are:

- Home
- Audio Input
- Audio Output
- Process
- MPX
- Multimedia** (expanded)
 - Sources
 - Stream 1 Decoder
 - Stream 2 Decoder
 - File Player
 - Changeover
 - Stream Encoder
- RDS/RBDS
- Signals Explorer
- Users
- System Settings
- Save/Load Config.
- Logs
- Version Info

MPEG-2

Mode
Stereo
Sample Rate
48 kHz

Mode: Select here the Mode of the MPEG-2 audio decoded.

Sample Rate: Select here the Sample Rate of the MPEG-2 audio decoded.



Default Admin
Default Administrator

1 LOGGED USER

- Home
- Audio Input
- Audio Output
- Process
- MPX
- Multimedia
 - Sources
 - Stream 1 Decoder
 - Stream 2 Decoder
 - File Player
 - Changeover
 - Stream Encoder
- RDS/RBDS
- Signals Explorer
- Users
- System Settings
- Save/Load Config.
- Logs
- Version Info



5.2.1.2 FILE PLAYER

To load new audio files inside the device you have to connect with it through an **FTP Client** (in this example we use Filezilla). The device must be reachable.

In the following line you can read for the **FTP Credentials** useful for the connections:

Host: **device IP** User: **sdcard-data** Password: **ax-sdcard**

Click on the **media** folder and paste the new firmware file in the red area as shown in the picture.

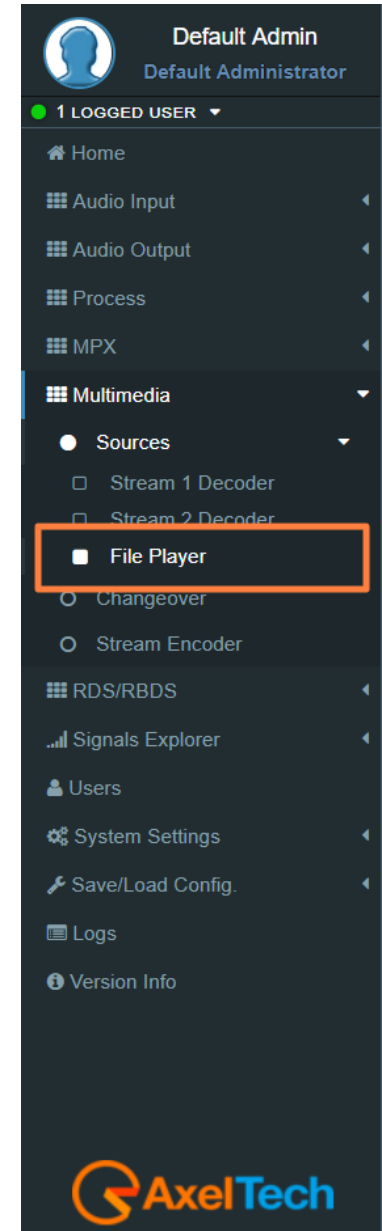
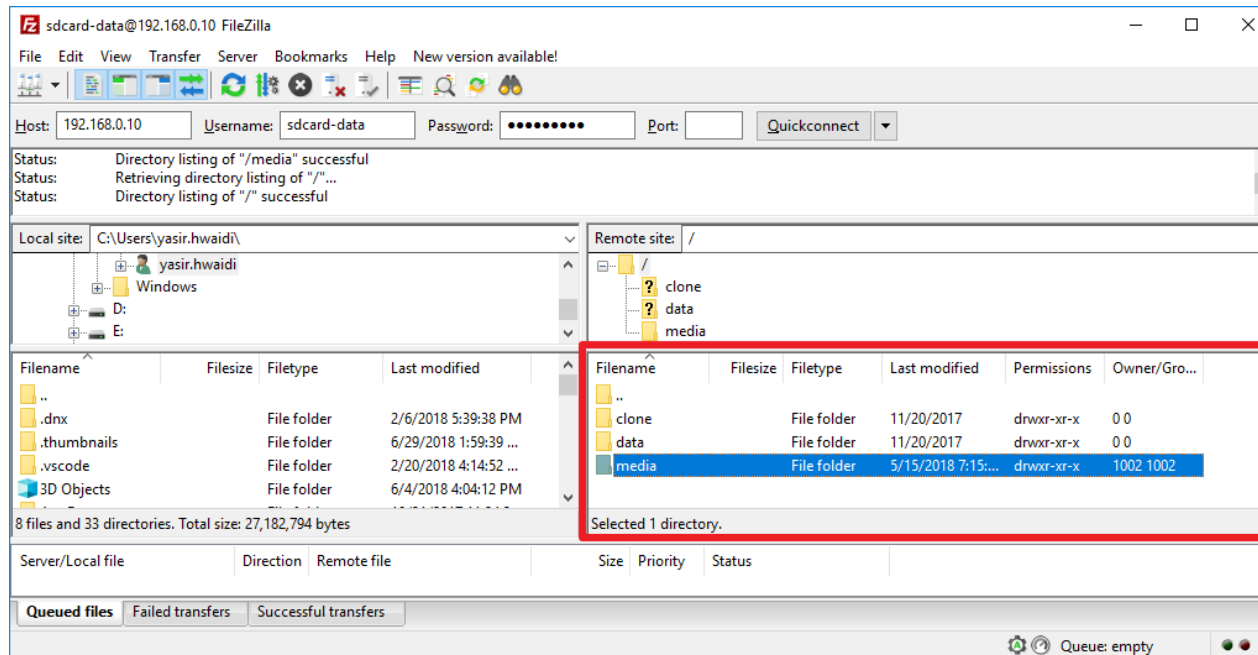

STATUS (The status parameter are only readable)

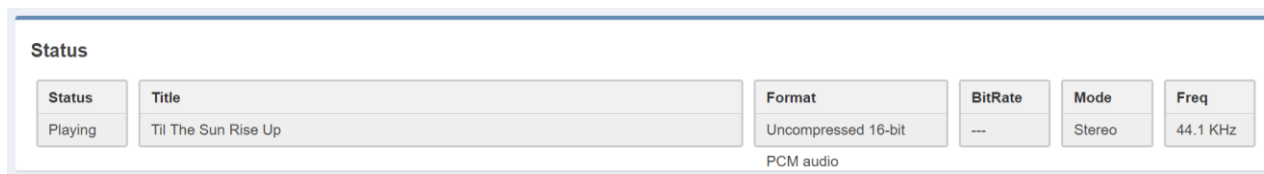

CONFIGURATION

Configuration

Mode Enabled	Buffer (ms) 3000
Output Gain (dB) -6.0	Play Order Alphabetic

Mode: Enable/Disable the File Player from SD.

Buffer (ms): Set here the desired buffer (ms).

Output Gain (dB): Set here the desired output gain for the File Player.

Play Order: Set here the Play Order, decide between Shuffle, Alphabetic, By Date.

Default Admin
Default Administrator

1 LOGGED USER

- Home
- Audio Input
- Audio Output
- Process
- MPX
- Multimedia
 - Sources
 - Stream 1 Decoder
 - Stream 2 Decoder
 - File Player**
 - Changeover
 - Stream Encoder
- RDS/RBDS
- Signals Explorer
- Users
- System Settings
- Save/Load Config.
- Logs
- Version Info

5.2.2 CHANGEOVER

Multimedia Changeover switch between two Decoders and Multimedia Player in AUTOMATIC or MANUAL mode.

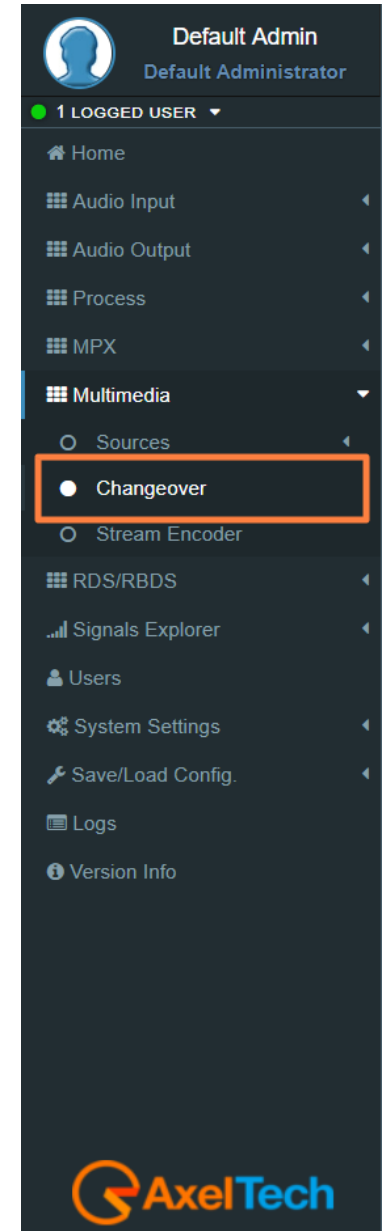
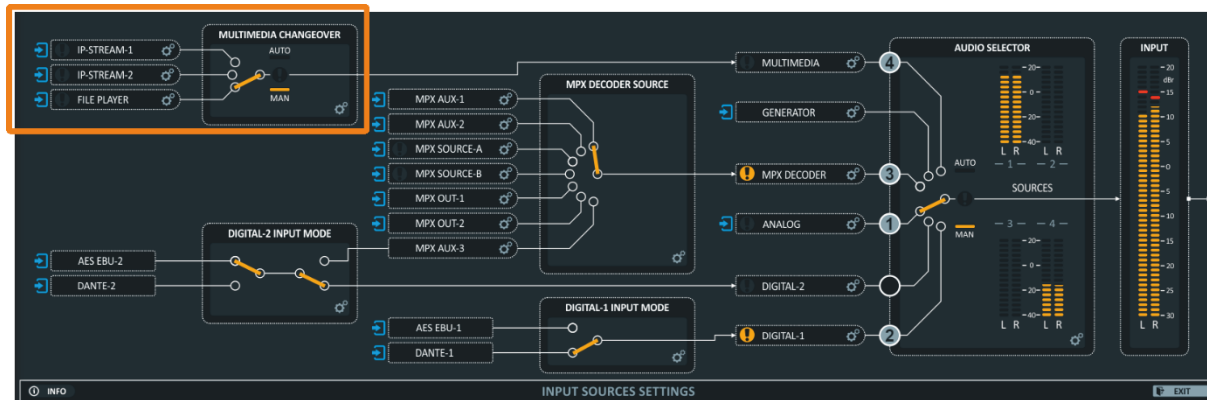

Configuration

Configuration

Multimedia Changeover Mode

FilePlayer

Multimedia Changeover Mode: can choose between three sources including the **MULTIMEDIA MODULE** (Decoder1, Decoder2, FilePlayer) or can select Auto to switch automatically at the source available.

Multimedia Changeover Events.

Multimedia Changeover Events

● unmasked Multimedia Changeover Failure Alarm

Multimedia Changeover Events: Masked /Unmasked the Alarm or notifications related to the connection between the device and one or more SMTP Servers.

5.2.3 STREAM ENCODER

STATUS (The status parameters are only readable)

Status					
Status	Protocol	Encoder	BitRate	Mode	Freq
Connected	Icecast Server	MP3	192kBits	Stereo	48 KHz

Status: Encoder Status

Protocol: Transport protocol

Encoder: Format of the encoded signal

BitRate: BitRate – the bits conveyed or processed per unit of time

Mode: Stereo or Mono

Freq: Sampling rate

CONFIGURATION

Configuration	
Mode IcecastServer-WebAudioHighQuality	Input Gain (dB) 1.0
Multicast Tx Enable Enabled	Multicast Host 239.10.1.3
Multicast TTL 1	

Mode: Select here the Protocol of the Transport and the format of the encoded signal

Input Gain: Type here the gain that you want to assign to the signal

Multicast Tx Enable: Enable or Disable the Multicast transmission.

Multicast Host: Type here the address of the Multicast Host.

Multicast TTL: Time-to-live (TTL)

Force Encoder Restart: This command forces the encoder restart.

The screenshot shows the 'Default Admin' interface. At the top, it says 'Default Admin' and 'Default Administrator'. Below that, it indicates '1 LOGGED USER'. A navigation menu on the right lists various options: Home, Audio Input, Audio Output, Process, MPX, Multimedia, Sources, Changeover, Stream Encoder (highlighted with an orange box), RDS/RBDS, Signals Explorer, Users, System Settings, Save/Load Config., Logs, and Version Info. The AxelTech logo is visible at the bottom of the interface.

TRANSPORT MODE

ICECAST SOURCE

If you have an external Icecast server here you can set all the parameters to stream your audio into a specific mount point of your Icecast.

Uri	<input type="text"/>
Source Port	<input type="text" value="1"/>
Username	<input type="text"/>
Password	<input type="password"/>
Mount Point	<input type="text" value="tge5"/>
Tag Enable	<input type="text" value="Disabled"/>
Tag Title	<input type="text" value="POLLOLANDIA"/>

Uri: Set the Url of your Icecast server

Source Port: set the Icecast port in which your audio will be sent

Username: Username for the authentication

Password: Password for the authentication

Mount Point: Type here the Mount point in which your audio will be sent.

Tag Enable: Set here if you want to enable or disable your Icecast Source

Tag Title: Give a title to your Icecast

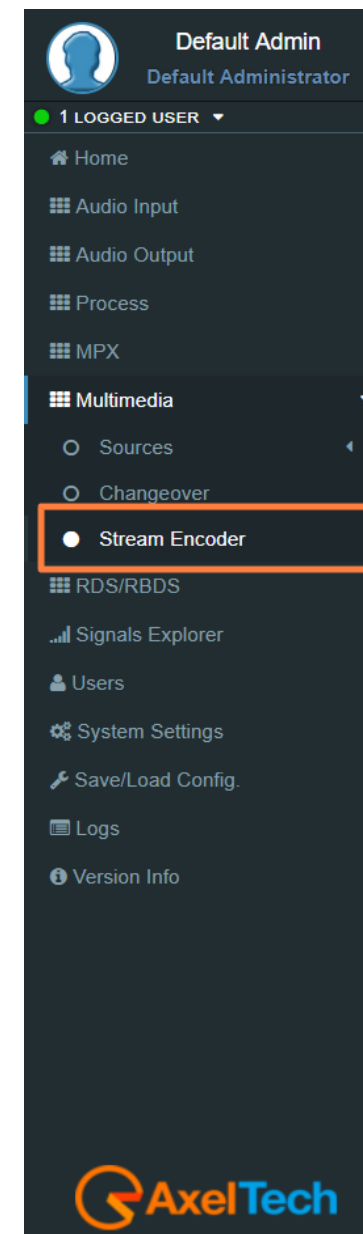

ICECAST SERVER

If you don't have an external Icecast Server you can distribute the audio directly to your listeners as if your device would be an Icecast Server. This Mode, differently from the Icecast Source, could have only a few users.

Mount Point
tge5
Tag Enable
Enabled
Tag Title
sdsdsd

Mount Point: Type here the Mount point in which your audio will be sent

Tag Enable: Set here if you want to enable or disable your Icecast Source

Tag Title: Give a title to your device used as Icecast.

RTP

Host
172.20.0.52
Port
5656

Host: Type here the IP address of your RTP decoder.

Port: Type here the Port of your RTP decoder.

UDP

Host
172.20.0.52
Port
5656

Host: Type here the IP address of your UDP decoder.

Port: Type here the Port of your UDP decoder.

The screenshot shows the 'Default Admin' interface. At the top, it says 'Default Administrator' and '1 LOGGED USER'. A sidebar menu is visible on the right, with 'Multimedia' expanded. Under 'Multimedia', 'Stream Encoder' is selected and highlighted with an orange box. Other options in the menu include Home, Audio Input, Audio Output, Process, MPX, Sources, Changeover, RDS/RBDS, Signals Explorer, Users, System Settings, Save/Load Config., Logs, and Version Info.

CODEC SETTINGS

VORBIS

Rate	192kBits
Mode	Stereo
Sample Rate	48 kHz

Rate: Select the Rate of the Vorbis audio encoding.

Mode: Select the Mode of the Vorbis audio encoding.

Sample Rate: Select the Sample Rate of the Vorbis audio encoding.

MP3

Rate	128kBits
Mode	Stereo
Sample Rate	32 kHz

Rate: Select the Rate of the MP3 audio encoding.

Mode: Select the Mode of the MP3 audio encoding.

Sample Rate: Select the Sample Rate of the MP3 audio encoding.

Default Admin
Default Administrator

● 1 LOGGED USER ▾

- [Home](#)
- [Audio Input](#)
- [Audio Output](#)
- [Process](#)
- [MPX](#)
- [Multimedia](#) ▾
 - Sources
 - Changeover
 - Stream Encoder**
- [RDS/RBDS](#)
- [Signals Explorer](#)
- [Users](#)
- [System Settings](#)
- [Save/Load Config.](#)
- [Logs](#)
- [Version Info](#)

OPUS

Rate	256kBits
Mode	Stereo
Sample Rate	48 kHz
Bandwidth	Full Band

Rate: Select the Rate of the Opus audio encoding.

Mode: Select the Mode of the Opus audio encoding.

Sample Rate: Select the Sample Rate of the Opus audio encoding.

Bandwidth: Select the Bandwidth of the Opus audio encoding.

RAW 16 BIT

Mode	Stereo
Sample Rate	32 kHz

Mode: Select the Mode of the Raw 16 Bit audio encoding.

Sample Rate: Select the Sample Rate of the Raw 16-bit audio encoding.



Default Admin
Default Administrator

● 1 LOGGED USER ▾

- 🏠 Home
- 🔧 Audio Input
- 🔧 Audio Output
- 🔧 Process
- 🔧 MPX
- 🔧 **Multimedia** ▾
 - Sources
 - Changeover
 - **Stream Encoder**
- 🔧 RDS/RBDS
- 📶 Signals Explorer
- 👤 Users
- ⚙️ System Settings
- 🔧 Save/Load Config.
- 📄 Logs
- ℹ️ Version Info



AAC

Rate	128kBits
Mode	Stereo
Sample Rate	48 kHz

Rate: Select the Rate of the AAC audio encoding.

Mode: Select the Mode of the AAC audio encoding.

Sample Rate: Select the Sample Rate of the AAC audio encoding.

MPEG-2

Rate	128kBits
Mode	Stereo
Sample Rate	32 kHz

Rate: Select the Rate of the MPEG-2 audio encoding

Mode: Select the Mode of the MPEG-2 audio encoding.

Sample Rate: Select the Sample Rate of the MPEG-2 audio encoding.

The screenshot shows the Default Admin interface. At the top, it says "Default Admin" and "Default Administrator". Below that, it indicates "1 LOGGED USER". The main menu includes: Home, Audio Input, Audio Output, Process, MPX, Multimedia (expanded), Sources, Changeover, Stream Encoder (highlighted with an orange box), RDS/RBDS, Signals Explorer, Users, System Settings, Save/Load Config., Logs, and Version Info. The AxelTech logo is at the bottom.

5.3 RDS/RBDS (NOT IN FALCON D7)

In RDS/RBDS section you can set all the parameters from RadioText to AF, from EON to PTY/PTYN. You can also set all Extended RDS/RBDS parameters.

In this section, you can setup all the parameters.

5.3.1 UECP PORTS (UNIVERSAL ENCODER COMMUNICATIONS PROTOCOL)

From this section, you can set communication parameters with available remote devices. These devices must be able to send UECP packets from their serial ports. *Version UECP_7_05_100224 standard.*

5.3.1.1 SERIAL PORTS

Serial Port setup

To interface properly target's serial ports the right configuration must be set as described below:

Data: 8 bits, Stop bits: 1, Parity: None and Flow control: None.

Serial 1&2 Port Configuration

Serial 1 Port Configuration	Serial 2 Port Configuration
Speed 38400 bps	Speed 38400 bps
Communication Mode Bidirectional Requested	Communication Mode Bidirectional Requested
Timeout No Action	Timeout No Action

Speed: No action, 75 bps -115200 bps.

Communication Mode: Unidirectional, Bidirectional Spontaneous, Bidirectional Requested.

Timeout: No action, 1 min - 10 min, Inactive.

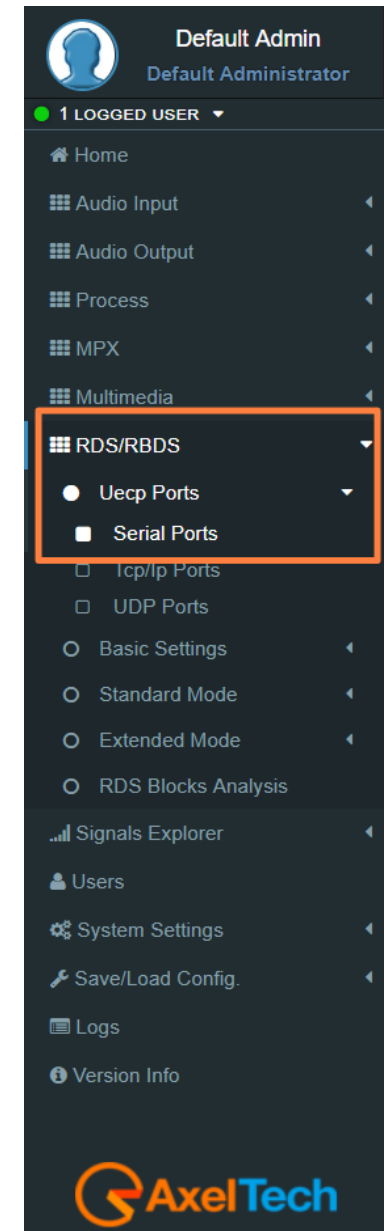

5.3.1.2 TCP/IP PORTS

From this section, you can set communication parameters with available remote devices. These devices must be able to send UECP packets through the TCP/IP protocol.

TCP/IP Port addresses

Target's TCP/IP ports are reachable at:

Tcp/Ip Port 1: **10000**, Tcp/Ip Port 2: **10001**, Tcp/Ip Port 3: **10002**, Tcp/Ip Port 4: **10003**.

Tcp/Ip 1, 2, 3 & 4 Port Configuration

<p>Tcp/Ip 1 Port Configuration</p> <p>Mode Normal Priority</p> <p>Communication Mode Bidirectional Requested</p> <p>Timeout No Action</p>	<p>Tcp/Ip 2 Port Configuration</p> <p>Mode Normal Priority</p> <p>Communication Mode Bidirectional Requested</p> <p>Timeout No Action</p>
<p>Tcp/Ip 3 Port Configuration</p> <p>Mode Normal Priority</p> <p>Communication Mode Bidirectional Requested</p> <p>Timeout No Action</p>	<p>Tcp/Ip 4 Port Configuration</p> <p>Mode Normal Priority</p> <p>Communication Mode Bidirectional Requested</p> <p>Timeout No Action</p>

Mode: No Action, Low Priority, Normal Priority, High Priority.

Communication Mode: Unidirectional, Bidirectional Spontaneous, Bidirectional Requested.

Timeout: No action, 1 min - 254 min, Inactive.

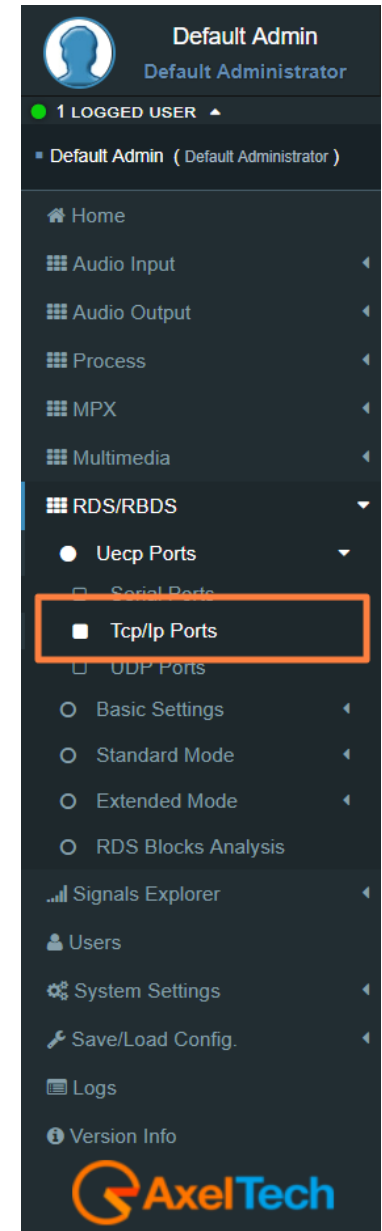

5.3.1.3 UDP & SNMP PORTS

From this section, you can set communication parameters with available UDP remote devices. These devices must be able to send UECF packets through UDP protocol.

UDP Port addresses

Target's UDP ports are reachable at:

Udp Port 1: **11000**, Udp Port 2: **11001**, Udp Port 3: **11002**, Udp Port 4: **11003**.

UDP 1, 2, 3 & 4 Port Configuration

<p>UDP 1 Port Configuration</p> <p>Mode No Action</p> <p>Timeout No Action</p>	<p>UDP 2 Port Configuration</p> <p>Mode Normal Priority</p> <p>Timeout No Action</p>
<p>UDP 3 Port Configuration</p> <p>Mode Normal Priority</p> <p>Timeout No Action</p>	<p>UDP 4 Port Configuration</p> <p>Mode Normal Priority</p> <p>Timeout No Action</p>

Mode: No Action, Low Priority, Normal Priority, High Priority

Timeout: No action, 1 min - 254 min, Inactive

The screenshot shows the user interface for the 'Default Admin' (Default Administrator). The navigation menu includes the following items:

- Home
- Audio Input
- Audio Output
- Process
- MPX
- Multimedia
- RDS/RBDS
 - Uecp Ports (highlighted with an orange box)
 - Serial Ports
 - Tcp/Ip Ports
 - UDP Ports
 - Basic Settings
 - Standard Mode
 - Extended Mode
 - RDS Blocks Analysis
- Signals Explorer
- Users
- System Settings
- Save/Load Config.
- Logs
- Version Info

5.3.2 BASIC SETTINGS

5.3.2.1 UECP ADDRESSING

The recipient encoder, getting UECP data frames from remote devices, must be identifiable by a unique address: **Site (Zone) + Encoder ID**. The remote devices will send UECP data frames to recipients through this addressing data couple. For example, a UECP data frame could be sent to all RDS devices of the desired Site or to the same Encoder ID of all Sites.

This section is used to set the individual device UECP address. In **Individual Address** set RDS site number and encoder number.

Individual Address

Site(Zone): assign to your device the desired site number

Encoder: assign to your device a desired encoder ID number

Uecp Address

Here you can have all the **Uecp Addresses** list.

Site Addresses: the range of possible values is 1 to 1023

Encoder Addresses: the range of possible values is 1 to 63

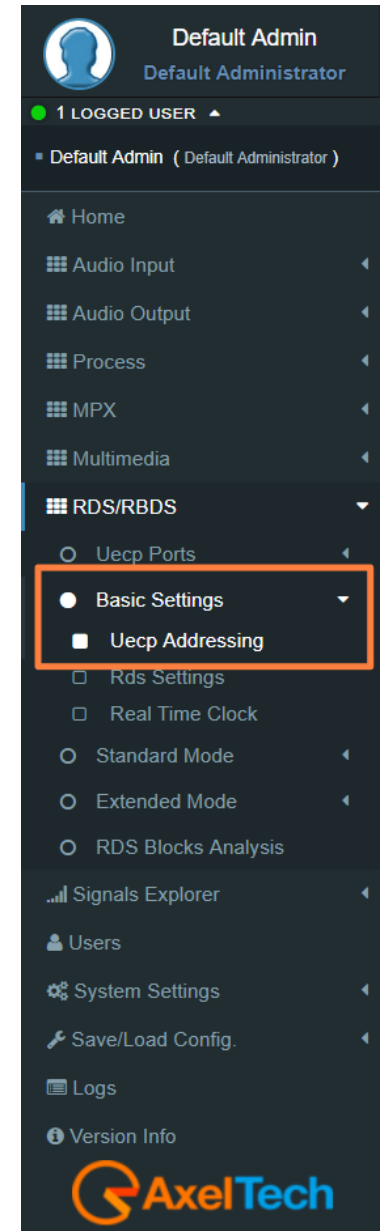

5.3.2.2 RDS SETTINGS

Rds General Settings

Rds General Settings

Rds On

Rds Global Extended Mode
Enabled

Rds Synchronism
Internal

PS Char Table Select
No Control Chars

Max Exported DataSet Number
1

Rds On: In the device Enable/Disable the RDS encoding.

Rds Global Extended Mode: Enable/Disable the Extended Mode.

Rds Synchronism (Pilot Synch): Internal, Auto Sync In (External & Digital), Auto Mpx In(External & Analogue).

PS Char Table Select: we suggest you to leave this parameter in **No Control Chars**.

A receiver, that entirely supports the character coding as defined in the RDS standard, probably does not exist. An assumption, that recent receivers give better results than older types, is valid only partially.

In default of a code table switching character, the display coding taking effect at address 0 should be assumed to be in accordance with code table. Thus when using only the default **Characters Table**, **No Control Chars** switching is required.

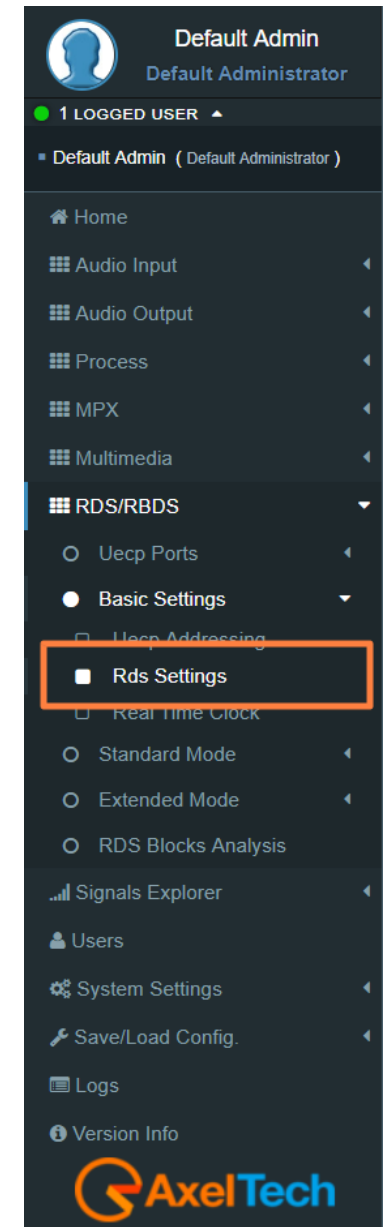

Active Dataset Selection

Active Dataset Selection

On Air Active Dataset

1

On Air Active Dataset: select the Data Set number that you want to air.

Rds Levels

Rds Levels

Current Level and Phase Reference Table Index

3

Level and Phase Reference Table		
	Level (mVpp)	Phase (Deg)
1	50	0.0
2	80	0.0
3	85	0.0
4	50	0.0
5	50	0.0
6	50	0.0

Current Level and Phase Reference Table Index: in the next field, enter the index number of the table row The related signal **Level** and signal **Phase** couple will be aired.

Level and Phase Reference Table: available, choosable and editable **Levels**(mVpp: millivolt peak-to-peak) and related **Phases**(Deg: Degrees).

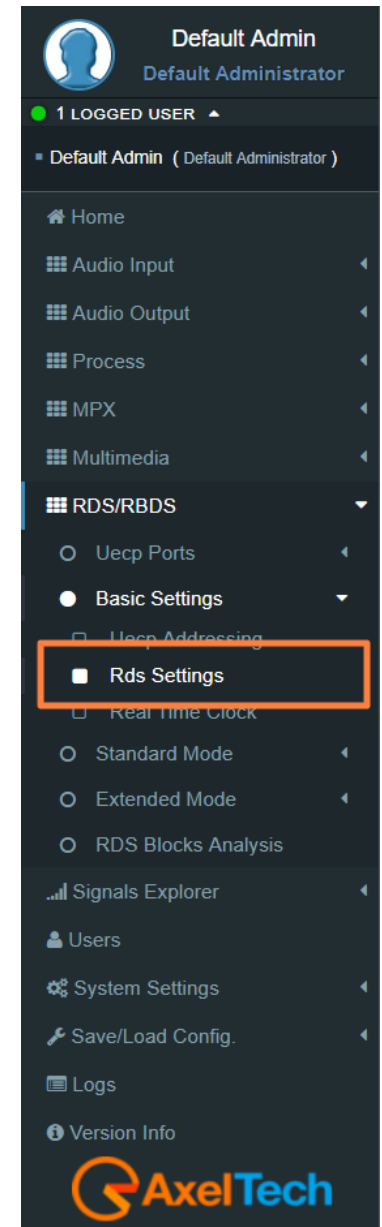

The following two parameter groups manage the special transitions of 15B group and 14B group in the standard RDS group sequence at the TA/EON TA - ON/OFF.

TA Control (15B)

TA TRAFFIC ANNOUNCEMENT IDENTIFICATION control force the transition of the 15B group in the standard RDS group sequence in relation with the activation/deactivation of the TA.

TA Control (15B)

Minimum Group Spacing <input style="width: 90%;" type="text" value="0"/>	ON Transition 15B Groups <input style="width: 90%;" type="text" value="0"/>	OFF Transition 15B Groups <input style="width: 90%;" type="text" value="0"/>
---	--	---

Minimum Group Spacing: number of groups of the standard RDS sequence, between two recurrences of the 15B groups will be inserted and transmitted.

ON Transition 15B(fast signal switching) Groups: only when TA is turned-ON, this parameter decides the number of 15B groups transmitted in a single recurrence.

OFF Transition 15B Groups: only when TA is turned-OFF, this parameter decides the number of 15B groups transmitted in a single recurrence.

EON TA Control (14B)

This control force the transition of the 14B group in the standard RDS group sequence in relation to the activation/deactivation of the EON TA.

EON TA Control (14B)

Minimum Group Spacing <input style="width: 90%;" type="text" value="0"/>	ON Transition 14B Groups <input style="width: 90%;" type="text" value="0"/>	OFF Transition 14B Groups <input style="width: 90%;" type="text" value="0"/>
---	--	---

Minimum Group Spacing: number of groups of the standard RDS sequence, between two recurrences of the 14B groups will be inserted and transmitted.

ON Transition 14B(fast signal switching) Groups: only when EON TA is turned-ON, this parameter decides the number of 14B groups transmitted in a single recurrence.

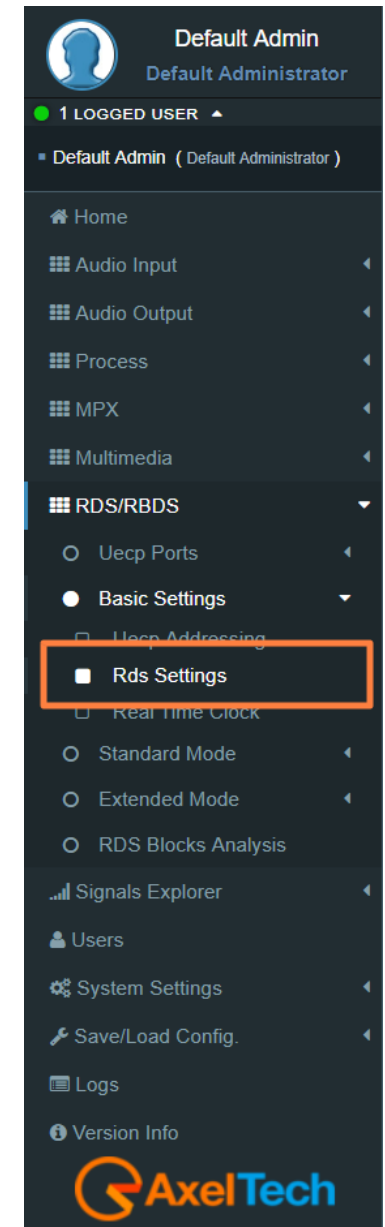

OFF Transition 14B Groups: only when EON TA is turned-OFF, this parameter decides the number of 14B groups transmitted in a single Recurrence.

SMB/SAMBA Share Settings

SMB/SAMBA Share Settings

File Name PLAYLIST.XML	Format DjPro V.2.0
Status All Right	

File Name: in this field type the file name. The RDS will search in the previously set SMB/SAMBA IP/FOLDER for song and author information.

Format: Choose between DjPro V.1.0, DjPro V.2.0, Dalet Simple, MB Studio.

Status: in this field, you can see if the file is found or not

RDS Events

RDS Events

●	masked	Rds Off Alarm
●	masked	Pilot Sync Alarm
●	masked	Smb/Samba Share Rds Alarm

Masked/Unmasked Pilot Sync Alarm: Mask/Unmask the alarm of the synchronization between a Pilot frequency and the encoder.

Masked/Unmasked Smb/Samba Share Rds Alarm: Mask/Unmask the alarm of the connection with the communication folder with your layout.

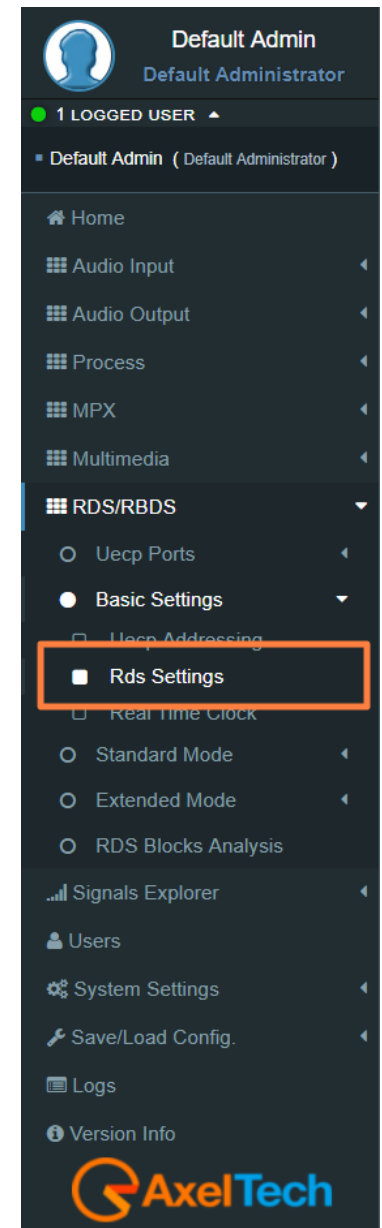

5.3.2.3 REAL TIME CLOCK

RTC Settings

RTC Settings

CT On/Off

Local Time Offset
+2:00 hrs

Real Time Clock Correction (ms)
0

CT On/Off: enable/disable the transmission of RDS Time clock.

Local Time Offset: Select here the desired Local Time Offset.

Real Time Clock Correction (ms): to avoid delays related to the signal transmission-reception, insert here a clock correction time(ms).

Default Admin
 Default Administrator

● 1 LOGGED USER ▲

▾ Default Admin (Default Administrator)

- 🏠 Home
- 🔧 Audio Input
- 🔧 Audio Output
- 🔧 Process
- 🔧 MPX
- 🔧 Multimedia
- 🔧 RDS/RBDS ▼
- Uecp Ports
- Basic Settings ▼
- Uecp Addressing
- Rds Settings
- Real Time Clock
- Standard Mode
- Extended Mode
- RDS Blocks Analysis
- 📶 Signals Explorer
- 👤 Users
- ⚙️ System Settings
- 🔧 Save/Load Config.
- 📄 Logs
- ℹ️ Version Info

5.3.3 STANDARD MODE

5.3.3.1 UECP SERVICES

Dataset General Settings

Dataset General Settings

Editing Dataset Index

DSN 1

Editing Dataset Index: Select here the desired Index to start the related Dataset editing.

PSN List

PSN List

PSN List

REFERENCE	Main	Eon1	Eon2	Eon3	Eon4	Eon5	Eon6	Eon7	Eon8	Eon9	Eon10
PS-NUMBER	001	002	003	004	005	006	007	008	009	010	011
ENABLED	-E-	-E-	---	---	---	---	---	---	---	---	---

Reference: in the reference, you can read all the available reference names

PS-Number: PS-Number of the related reference

ENABLED: (-E- : PSN enabled) (--- : PSN disabled)

PSN List Enable

PSN List Enable

EON 1
EON 2
EON 3
EON 4
EON 5
EON 6
EON 7
EON 8
EON 9
EON 10

MAIN PS
EON 1 ✖

EON 1 : Enabled EON. If the EON is enabled you can see EON 1 ✖ in the bottom section. To disable it click on the related ✖ .

EON 2 : Disabled EON. To enable it, click on it.

Default Admin
Default Administrator

1 LOGGED USER

- Home
- Audio Input
- Audio Output
- Process
- MPX
- Multimedia
- RDS/RBDS
 - Uecp Ports
 - Basic Settings
 - Standard Mode
 - Uecp Services
 - Uecp Main PS
 - Uecp Main AF
 - Uecp Radiotext
 - Uecp Eon PS
 - Uecp Eon AF
 - Extended Mode
 - RDS Blocks Analysis
- Signals Explorer
- Users
- System Settings
- Save/Load Config.
- Logs
- Version Info

MENU | RDS/RBDS (NOT IN FALCON D7)

121

Group List

In the following mask, you can decide the Group List and the group sequence order.

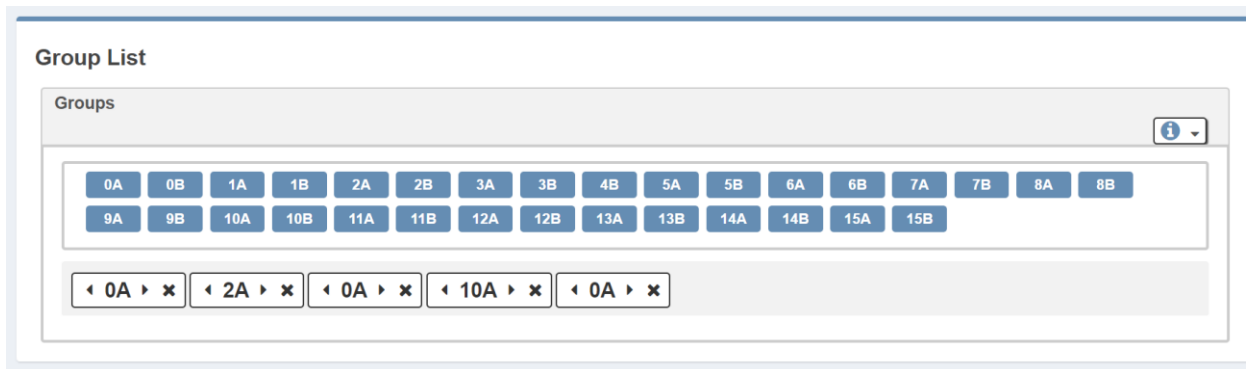

0A : to add the group at the end of the group sequence.

In the bottom section, you see the list of group sequence.

< 0A > x represents a present group inside the group sequence.

By clicking on **◀** you move it in the previous sequence position.

By clicking on **▶** you move it in the following order position.

By clicking on **✕** you erase it from the sent RDS/RBDS groups.

ON AIR GROUPS

<i>Services</i>	<i>RDS groups</i>
Programme Identification (PI) code	All
Programme Type (PTY) code	All
Traffic Programme (TP) identification code	All
Programme Service (PS) name	0A, 0B
Alternative frequency (AF) code pairs	0A
Traffic announcement (TA) code	0A, 0B, 14B, 15B
Decoder identification (DI) code	0A, 0B, 15B
Music Speech (MS) code	0A, 0B, 15B
RadioText (RT) message	2A, 2B
Enhanced other networks information	14A

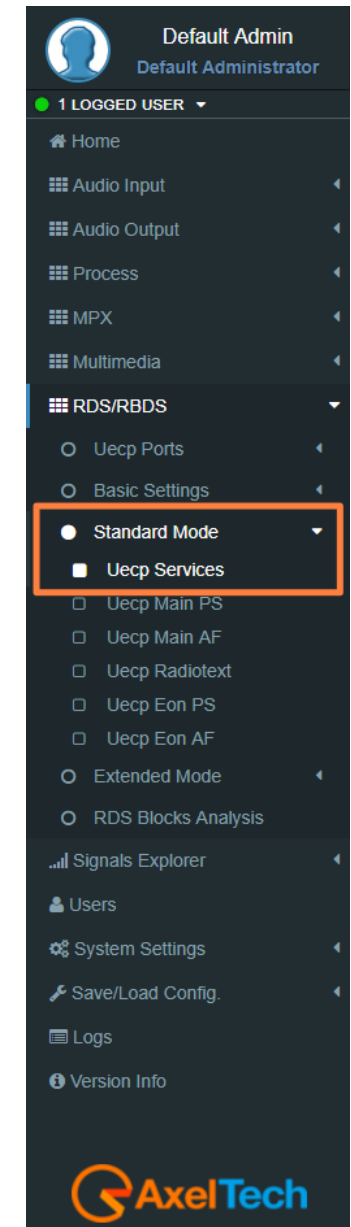

Group Type	Description of Use
0 A	Basic tuning and switching information only
0 B	Basic tuning and switching information only
1A	Program Item Number and slow labelling codes only
1B	Program Item Number
2 A	Radiotext only
2 B	Radiotext only
3 A	Applications Identification for ODA only
3 B	Open Data Applications
4 A	Clock-time and date only
4 B	Open Data Applications
5 A	Transparent Data Channels (32 channels) or ODA
5 B	Transparent Data Channels (32 channels) or ODA
6 A	In House applications or ODA
6 B	In House applications or ODA
7 A	Radio Paging or ODA
7 B	Open Data Applications
8 A	Traffic Message Channel or ODA
8 B	Open Data Applications
9 A	Emergency Warning System or ODA
9 B	Open Data Applications
10 A	Program Type Name
10 B	Open Data Applications
11 A	Open Data Applications
11 B	Open Data Applications
12 A	Open Data Applications
12 B	Open Data Applications
13 A	Enhanced Radio Paging or ODA
13 B	Open Data Applications
14 A	Enhanced Other Networks information only
14 B	Enhanced Other Networks information only
15 A	Undefined
15 B	Fast switching information only

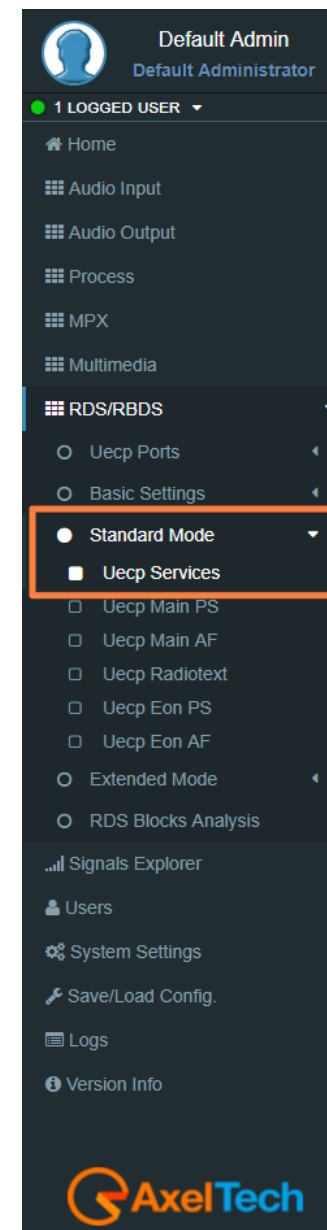

By clicking on  you can open the following top describing table that indicates to the specific work of groups:

Group List

Groups

0A : Basic Tuning & Switching Info	6A : IH	12A : ODA data
0B : Basic Tuning & Switching Info	6B : IH	12B : ODA data
1A : PIN/SLC	7A : RP	13A : ODA data
1B : PIN	7B : ODA data	13B : ODA data
2A : RT	8A : TMC	14A : EON
2B : RT	8B : ODA data	14B : EON
3A : ODA Registration	9A : EWS	15A : ODA data
3B : ODA data	9B : ODA data	15B : Fast switching info
4A : CT	10A : PTYN	
4B : ODA data	10B : ODA data	
5A : TDC	11A : ODA data	
5B : TDC	11B : ODA data	

0A0B1A1B2A2B3A3B4A4B5A5B6A6B7A7B8A8B9A9B10A10B11A11B12A12B13A13B14A14B15A15B

◀ 0A ▶ ✕
◀ 2A ▶ ✕
◀ 0A ▶ ✕
◀ 10A ▶ ✕
◀ 0A ▶ ✕

List of other useful abbreviations

AF	Alternative Frequencies list	MS	Music Speech switch
AID	Applications IDentification for ODA	ODA	Open Data Applications
ARI	Autofahrer Rundfunk Information	PI	Programme Identification
CI	Country Identifier	PIN	Programme Item Number
CT	Clock Time and date	PS	Programme Service name
DI	Decoder Identification	PTY	Program TYpe
ECC	Extended Country Code	PTYI	Dynamic Programme TYpe Indicator
EG	Extended Generic indicator	PTYN	Programme TYpe Name
EON	Enhanced Other Networks information	RBDS	Radio Broadcast Data System
EWS	Emergency Warning System	RDS	Radio Data System
IH	In House application	RP	Radio Paging
ILS	International Linkage Set indicator	RT	Radio Text
LA	Linkage Actuator	TA	Traffic Announcement flag
LI	Linkage Identifier	TDC	Transparent Data Channels
LSN	Linkage Set Number	TMC	Traffic Message Channel
TP	Traffic Programme flag		

Default Admin

Default Administrator

1 LOGGED USER

- Home
- Audio Input
- Audio Output
- Process
- MPX
- Multimedia
- RDS/RBDS
 - Uecp Ports
 - Basic Settings
 - Standard Mode
 - Uecp Services
 - Uecp Main PS
 - Uecp Main AF
 - Uecp Radiotext
 - Uecp Eon PS
 - Uecp Eon AF
 - Extended Mode
 - RDS Blocks Analysis
- Signals Explorer
- Users
- System Settings
- Save/Load Config.
- Logs
- Version Info

Group 1A Variant Sequence (SLC – Slow Labelling Codes)

In the following mask, you can decide the Group 1A Variant Sequence and his Slow Labelling Codes sequence order.

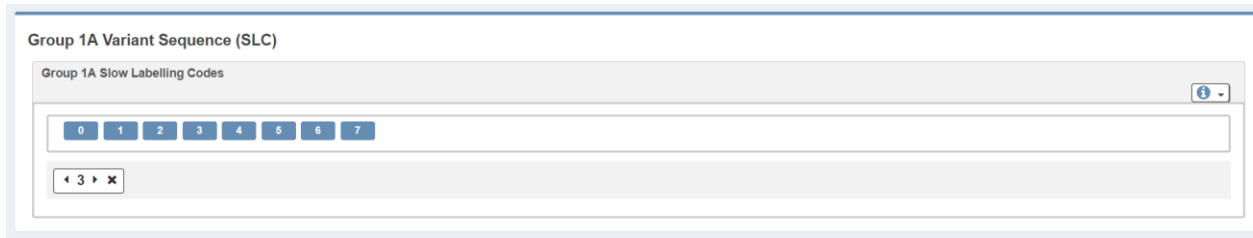

3 : to add the SLC at the end of the sequence.

In the bottom section, you see the list of SLC sequence.

◀ 3 ▶ X : represents a present SLC inside the sequence.

By clicking on ◀ you move it in the previous sequence position.

By clicking on ▶ you move it in the following order position.

By clicking on X you erase it from the transmitted SLCs.

By clicking on ⓘ you can open the following top describing table:

Group 1A Slow Labelling Codes ⓘ	
0 : ECC	4 : n/a
1 : n/a	5 : n/a
2 : Paging ID	6 : Broadcast
3 : Language Codes	7 : EWS Channel Id

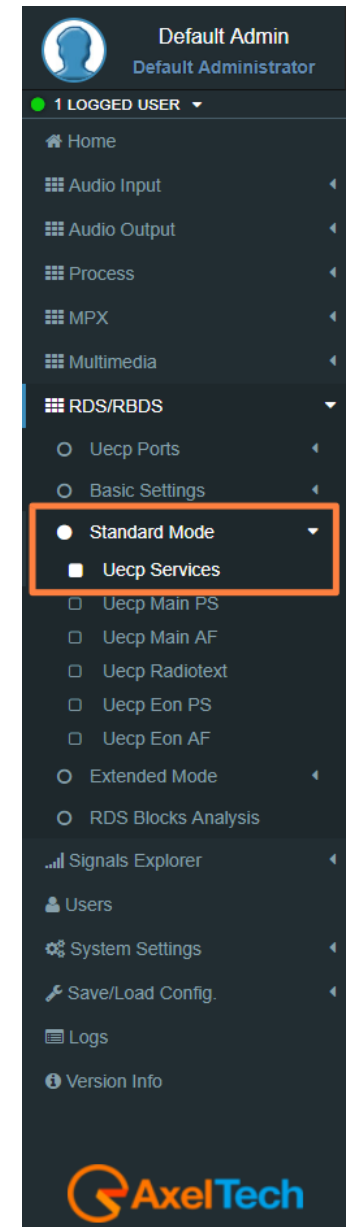

Group 14A Variant Sequence (EON – Enhanced Other Networks information)

In the following mask, you can decide the Group 14A Variant Sequence and his Codes sequence order.

3 : to add the Code at the end of the sequence.

In the bottom section, you see the list of Codes sequence.

< 3 > x : represents a present code inside the sequence.

By clicking on **◀** you move it in the previous sequence position.

By clicking on **▶** you move it in the following order position.

By clicking on **✕** you erase it from the transmitted codes list.

By clicking on **i** you can open the following top describing table:

Group 14 A			
0 : PS-ON	4 : AF-ON (A Method)	8 : AF-ON (Map Freq 4)	12 : Linkage
1 : PS-ON	5 : AF-ON (Map Freq 1)	9 : AF-ON (AM)	13 : TA/PTY-ON
2 : PS-ON	6 : AF-ON (Map Freq 2)	10 : n/a	14 : PIN-ON
3 : PS-ON	7 : AF-ON (Map Freq 3)	11 : n/a	

5.3.3.2 UECP MAIN PS

This section is useful to define all UECP Main PS parameters

Main Network Program Service

Main Network Program Service

Editing Dataset Index DSN 1	Editing Program Service Main PS
--------------------------------	------------------------------------

Editing Dataset Index: decide which Main PS you want to edit, select the related DSN (Dataset Number).

Editing Program Service: You will see this parameter also in UECP Eon PS. Here the parameters are not selectable because this is the MAIN Program.

Basic Settings

Basic Settings

PI 5301	PS hnology	
TP Off	TA Off	
PTY Varied	PTYN TestPTYN	
PIN Day 0	PIN Hour 0	PIN Minute 0
Music/Speech Music	Decoder Information Stereo	

Default Admin
 Default Administrator

● 1 LOGGED USER

- Home
- Audio Input
- Audio Output
- Process
- MPX
- Multimedia
- RDS/RBDS
 - Uecp Ports
 - Basic Settings
 - Standard Mode
 - Uecp Services
 - Uecp Main PS
 - Uecp Main AF
 - Uecp Radiotext
 - Uecp Eon PS
 - Uecp Eon AF
 - Extended Mode
 - RDS Blocks Analysis
- Signals Explorer
- Users
- System Settings
- Save/Load Config.
- Logs
- Version Info

PI(Program Identification): type the PI Code. Lock at

PS(Program Station): type the Program Station Name.

TP(Traffic Program): On/Off

TA(Traffic Announcement): On/Off

PTY: a selectable value between (Pop Music, Rock Music, Culture, Science...).

PTYN: type a desired description for the program.

PIN Day: if you want to schedule a special PTY insert here the month day. From 00 to 31.

PIN Hour: if you want to schedule a special PTY insert here the desired hour (HH). From 00 to 23.

PIN Minute: if you want to schedule a special PTY insert here the desired minute (MM). From 00 to 59.

Music/Speech: select here if you have a Music program or a Speech program.

Decoder Information: select the audio decoder information.

PI (Program identification)

This information consists of a code enabling the receiver to distinguish between countries, areas in which the same program is transmitted, and the identification of the program itself. The code is not intended for direct display and is assigned to each individual radio program, to enable it to be distinguished from all other programs. One important application of this information would be to enable the receiver to search automatically for an alternative frequency in case of bad reception of the program to which the receiver is tuned, the criteria for the change-over to the new frequency would be the presence of a better signal having the same **PI** code.

The **PI** code consists of four characters. The first two characters have special meaning, second two are used to clearly identify different stations.

The changes to the **PI** code assignment are summarized as follows:

- **PI** assignments below **B000** will remain as is, allowing **AF** switching but no regionalization. Call signs deriving **PI** codes “**x0xx**”, and “**xx00**” are re-mapped into the “**A**” range of **PI**’s.
- 3 Letters call signs – Modifications were made to the 3 letters call **PI** code assignment table.
- **C000 – CFFF** assigned to Canada. Allows **AF** switching, but no regionalization. **PI** codes **C0xx**, and **Cx00** are excluded from use.
- **F000 – FFFF** assigned to Mexico. Allows **AF** switching, but no regionalization. **PI** codes **F0xx**, and **Fx00** are excluded from use.

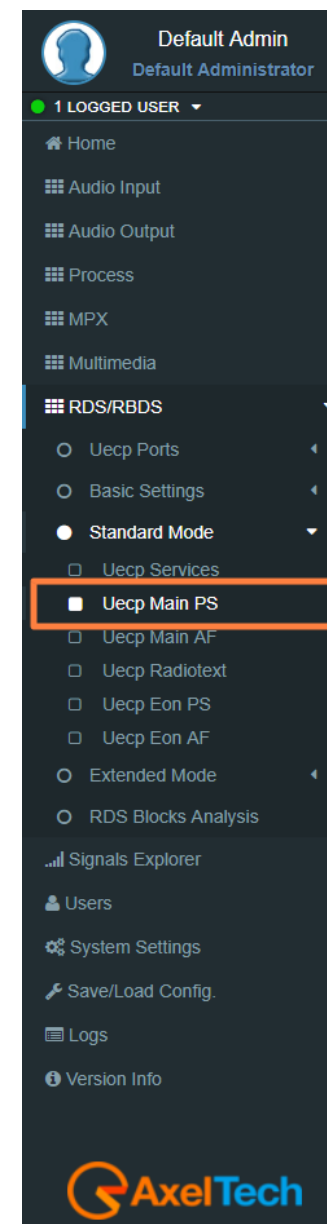

- **B_01 – B_FF, D_01 – D_FF, E_01 – E_FF** assigned for national networks in the US, Canada, and Mexico. Regionalization allowed. **NRSC** to provide assignments for all three countries. It should be noted that operation in this region is the same as it is for all **RDS PI** codes.

The first PI character identifies the country

5000

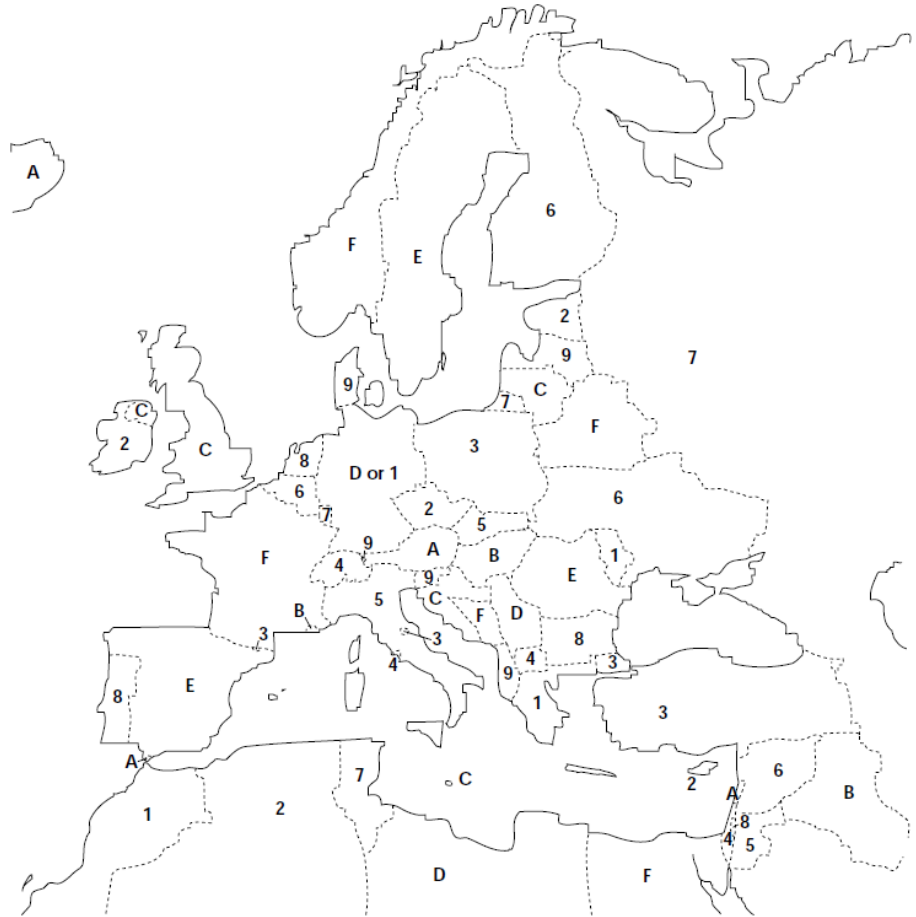

A screenshot of the Default Admin interface. The top bar shows 'Default Admin' and 'Default Administrator'. Below this, there is a '1 LOGGED USER' indicator. The main menu is on the right side, listing various system settings and services. The 'RDS/RBDS' menu is expanded, showing options like 'Uecp Ports', 'Basic Settings', 'Standard Mode', 'Uecp Services', 'Uecp Main PS', 'Uecp Main AF', 'Uecp Radiotext', 'Uecp Eon PS', 'Uecp Eon AF', 'Extended Mode', and 'RDS Blocks Analysis'. The 'Uecp Main PS' option is highlighted with an orange box. At the bottom of the interface, there is an 'AxelTech' logo.

<i>Country</i>	<i>ISO code</i>	<i>ECC</i>	<i>Country code</i>
Albania	AL	E0	9
Algeria	DZ	E0	2
Algeria	DZ	E0	2
Andorra	AD	E0	3
Angola	AO	D0	6
Ascension Island		D1	A
Austria	AT	E0	A
Azores(Portugal)	PT	E4	8
Belarus	BY	E3	F
Belgium	BE	E0	6
Benin	BJ	D0	E
Bosnia Herzegovina	BA	E4	F
Botswana	BW	D1	B
Bulgaria	BG	E1	8
Burkina Faso	BF	D0	B
Burundi	BI	D1	9
Cabinda		D3	4
Cameroon	CM	D0	1
Canaries (Spain)	ES	E2	E
Canary Island	ES	E0	E
Cape Verde	CV	D1	6
Central African Republic	CF	D0	2
Chad	TD	D2	9
Comoros	KM	D1	C
Congo	CG	D0	C

<i>Country</i>	<i>ISO code</i>	<i>ECC</i>	<i>Country code</i>
Cote d'Ivoire	CI	D2	C
Croatia	HR	E3	C
Cyprus	CY	E1	2
Czech Republic	CZ	E2	2
Democratic Republic of Congo	ZR	D2	B
Denmark	DK	E1	9
Djibouti	DJ	D0	3
Egypt	EG	E0	F
Egypt	EG	E0	F
Equatorial Guinea	GQ	D0	7
Estonia	EE	E4	2
Ethiopia	ET	D1	E
Faroe (Denmark)	DK	E1	9
Finland	FI	E1	6
France	FR	E1	F
Gabon		D0	8
Gambia	GM	D1	8
Germany	DE	E0	D or 1
Ghana	GH	D1	3
Gibraltar(United Kingdom)	GI	E1	A
Greece	GR	E1	1
Guinea-Bissau	GW	D2	A
Hungary	HU	E0	B
Iceland	IS	E2	A
Iraq	IQ	E1	B

<i>Country</i>	<i>ISO code</i>	<i>ECC</i>	<i>Country code</i>
Ireland	IE	E3	2
Israel	IL	E0	4
Italy	IT	E0	5
Jordan	JO	E1	5
Kenya	KE	D2	6
Latvia	LV	E3	9
Lebanon	LB	E3	A
Lesotho	LS	6	D3
Liberia	LR	D1	2
Libya	LY	E1	D
Libya	LY	E1	D
Liechtenstein	LI	E2	9
Lithuania	LT	E2	C
Luxembourg	LU	E1	7
Macedonia	MK	E3	4
Madagascar	MG	D0	4
Madeira (Portugal)	PT	E4	8
Malawi	MW	D0	F
Mali	ML	D0	5
Malta	MT	E0	C
Mauritania	MR	D1	4
Mauritius	MU	D3	A
Moldova	MD	E4	1
Monaco	MC	E2	B

<i>Country</i>	<i>ISO code</i>	<i>ECC</i>	<i>Country code</i>
Morocco	MA	E2	1
Mozambique	MZ	D2	3
Namibia	NA	D1	1
Netherlands	NL	E3	8
Niger	NE	D2	8
Nigeria	NG	D1	F
Norway	NO	E2	F
Palestine	PS	E0	8
Poland	PL	E2	3
Portugal	PT	E4	8
Republic of Guinea	GN	D0	9
Romania	RO	E1	E
Russian Federation	RU	E0	7
Rwanda	RW	D3	5
San Marino	SM	E1	3
Sao Tome & Principe	ST	D1	5
Senegal	SN	D1	7
Seychelles	SC	D3	8
Sierra Leone	SL	D2	1
Slovakia	SK	E2	5
Slovenia	SI	E4	9
Spain	ES	E2	E
Sweden	SE	E3	E
Switzerland	CH	E1	4

ECC	1	2	3	4	5	6	7	8	9	A	B	C	D	E	F
E0	DE	DZ	AD	IL	IT	BE	RU	PS	AL	AT	HU	MT	DE		EG
E1	GR	CY	SM	CH	JO	FI	LU	BG	DK	GI	IQ	GB	LY	RO	FR
E2	MA	CZ	PL	VA	SK	SY	TN		LI	IS	MC	LT	YU	ES	NO
E3		IE	TR	MK				NL	LV	LB		HR		SE	BY
E4	MD	EE				UA		PT	SI						BA

The second PI character identifies program type in terms of area coverage:

5000

- 0 - Local** (Local program transmitted via a single transmitter only during the whole transmitting time.)
- 1 - International** (The same program is also transmitted in other countries.)
- 2 - National** (The same program is transmitted throughout the country.)
- 3 - Supra-regional** (The same program is transmitted throughout a large part of the country.)
- 4 to F - Regional** (The program is available only in one location or region over one or more frequencies, and there exists no definition of its frontiers.)

If the entire hexadecimal code is already known, enter it into RDS/RBDS > Quick RDS Setup > PI.

Area coverage code	Local	International	National	Supra-regional	Regional1	Regional2	Regional3
HEX	0	1	2	3	4	5	6

Area coverage code	Regional4	Regional5	Regional6	Regional7	Regional8	Regional9	Regional10	Regional11	Regional12
HEX	7	8	9	A	B	C	D	E	F

The last two characters identify a hexadecimal number between $0_{16} < x < FF_{16}$ ($0_{10} < x < 256_{10}$) assigned by the telecommunications authority

5000

These last two characters are assigned by the National Telecommunications Authority.

PS (Program Service) NAME

Program Service Name is a text consisting of not more than eight alphanumeric characters which are displayed by **RDS** receivers in order to inform the listener what programme service is being broadcast by the station to which the receiver is tuned. An example of a **PS** name is "Radio 21". The Programme Service name is not intended to be used for automatic search tuning.

TP (Traffic Programme identification)

This is a flag to indicate that the tuned programme carries traffic announcements. The **TP** flag must only be set on programmes which dynamically switch on the **TA** identification during traffic announcements. The signal shall be considered during automatic search tuning.

TA (Traffic Announcement identification)

This is an **on/off** switching signal to indicate when a traffic announcement is on air. The signal could be used in receivers to:

- a) Switch automatically from any audio mode to the traffic announcement.
- b) Switch on the traffic announcement automatically when the receiver is in a waiting reception mode and the audio signal is muted.
- c) Switch from a programme to another one carrying a traffic announcement.

After the end of the traffic announcement, the initial operating mode will be restored.

PTY (Program Type)

This is an identification number to be transmitted with each programme item and which is intended to specify the current **Programme Type** within 31 possibilities. This code could be used for search tuning. The code will, moreover, enable suitable receivers and recorders to be pre-set to respond only to programme items of the desired type. The last number, i.e. 31, is reserved for an alarm identification which is intended to switch on the audio signal when a receiver is operated in a waiting reception mode.

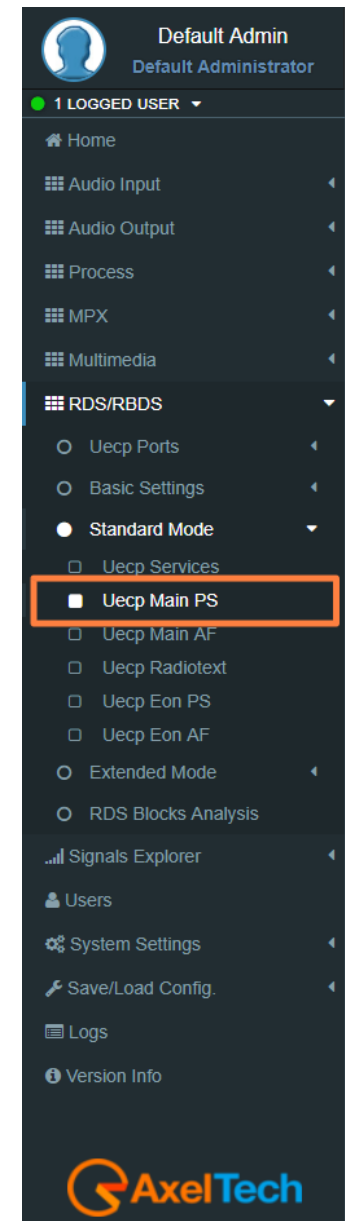

PTYN (Program Type Name)

The **PTYN** feature is used to further describe current **PTY**. **PTYN** permits the display of a more specific **PTY** description (max 8 characters) that the broadcaster can freely decide (e.g. **PTY:4** = Sport and **PTYN:** Football). The **PTYN** is not intended to change the default eight characters of **PTY** which will be used during search or wait modes, but only to show in detail the programme type once tuned to a programme. If the broadcaster is satisfied with a default **PTY** name, it is not necessary to use additional data capacity for **PTYN**. The Programme Type Name is not intended to be used for automatic **PTY** selection and must not be used for giving sequential information.

NOTE: the **PTY** only can be programmed accordingly to the **UECP** protocol. The **PTYN** is related to the **UECP** Extended (custom) RDS programming mode.

Number	PTY Code	PTY (Programme type)	8-character display	16-character display
0	00000	No programme type or undefined	None	None
1	00001	News	News	News
2	00010	Current Affairs	Affairs	Current Affairs
3	00011	Information	Info	Information
4	00100	Sport	Sport	Sport
5	00101	Education	Educate	Education
6	00110	Drama	Drama	Drama
7	00111	Culture	Culture	Cultures
8	01000	Science	Science	Science
9	01001	Varied	Varied	Varied Speech
10	01010	Pop Music	Pop M	Pop Music
11	01011	Rock Music	Rock M	Rock Music
12	01100	Easy Listening Music	Easy M	Easy Listening
13	01101	Light classical	Light M	Light Classics M
14	01110	Serious classical	Classics	Serious Classics
15	01111	Other Music	Other M	Other Music

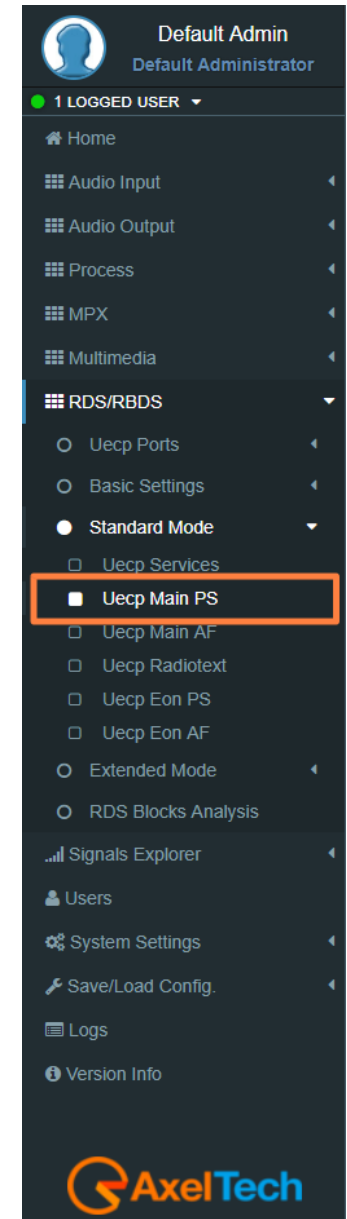

Due to differing broadcast styles, the program type code definitions (i.e. Jazz, Rock, etc.) differ between RDS and RBDS:

PTY Code	RDS Program Type	RBDS Program Type	PTY Code	RDS Program Type	RBDS Program Type
0	No program type or undefined	No program type or undefined	16	Weather	Rhythm and Blues
1	News	News	17	Finance	Soft Rhythm and Blues
2	Current Affairs	Information	18	Children's programs	Language
3	Information	Sports	19	Social Affairs	Religious Music
4	Sport	Talk	20	Religion	Religious Talk
5	Education	Rock	21	Phone In	Personality
6	Drama	Classic Rock	22	Travel	Public
7	Culture	Adult Hits	23	Leisure	College
8	Science	Soft Rock	24	Jazz Music	Unassigned
9	Varied	Top 40	25	Country Music	Unassigned
10	Pop Music	Country	26	National Music	Unassigned
11	Rock Music	Oldies	27	Oldies Music	Unassigned
12	M.O.R. Music	Soft	28	Folk Music	Unassigned
13	Light Classical	Nostalgia	29	Documentary	Weather
14	Serious Classical	Jazz	30	Alarm Test	Emergency Test
15	Other Music	Classical	31	Alarm	Emergency

PIN (Programme Item Number)

The code should enable receivers and recorders designed to make use of this feature to respond to the particular program item (s) that the user has preselected. Use is made of the scheduled programme time, to which is added the day of the month in order to avoid ambiguity.

Linkage

Linkage information provides the means by which several programme services, each characterised by its own PI code, may be treated by a receiver as a single service during times a common programme is carried. During such times each program service retains its unique identity, i.e. the programme service must keep its designated

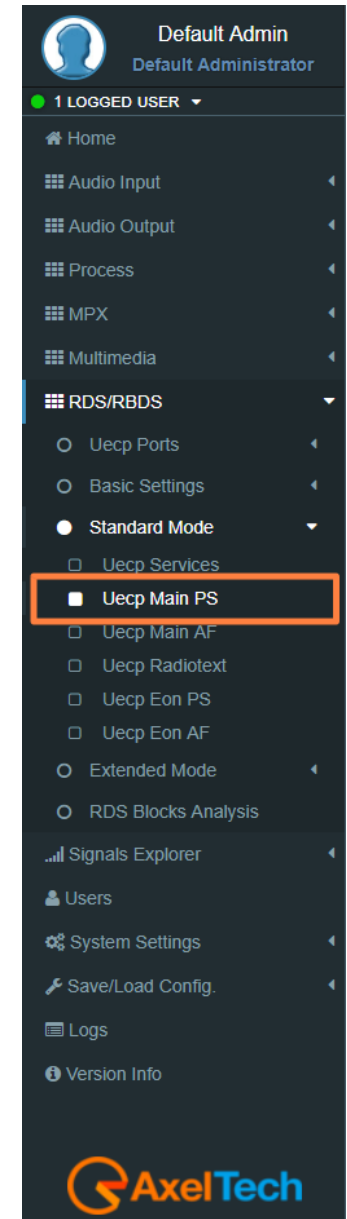

PI code and its **AF** (Alternative Frequency) list(s), but may change programme related features such as **PS**, **PTY**, **RT**, **TP** and **TA** to reflect the common programme;

Linkage information is conveyed in the following four data elements:

Linkage			
LA	EG	ILS	LSN
Off	Off	Off	000

LA: linkage actuator

EG: extended generic index

ILS: international linkage standard

LSN: linkage set number

Slow Labelling Codes (SLC)

The **RDS** specification contains some additional slow labelling codes that are used to support various features. These are specified to be carried in the type **1A group**. In this section, you can set **SLC** values.

Slow Labelling Codes			
SLC 0 (ECC)	SLC 1 (TMC)	SLC 2 (Paging)	SLC 3 (Language)
000	000	000	000
SLC 4 (n/a)	SLC 5 (n/a)	SLC 6 (Broad.)	SLC 7 (EWS)
000	000	000	000

SLC 0 (ECC) Extend Country Code: This code is only used when the EPP is used, it defined the selected country.

SLC 1 (TMC) Traffic Message Channel: This channel is used for road information, not used when **ODA** mode is used for **TMC**.

SLC 2 (Paging): This identification is used only with the international multi-operator.

The screenshot shows the 'Default Admin' interface. The user is logged in as 'Default Administrator'. The 'RDS/RBDS' menu is expanded, showing options like 'Uecp Ports', 'Basic Settings', 'Standard Mode', 'Uecp Services', 'Uecp Main PS' (highlighted with an orange box), 'Uecp Main AF', 'Uecp Radiotext', 'Uecp Eon PS', 'Uecp Eon AF', 'Extended Mode', and 'RDS Blocks Analysis'. Other menu items include 'Home', 'Audio Input', 'Audio Output', 'Process', 'MPX', 'Multimedia', 'Signals Explorer', 'Users', 'System Settings', 'Save/Load Config.', 'Logs', and 'Version Info'. The AxelTech logo is visible at the bottom.

- SLC 3 (Language):** This code allows to define language used by the broadcaster.
- SLC 4 (n/a):** not assigned.
- SLC 5 (n/a):** not assigned.
- SLC 6 (Broadcaster use):** Data reserved for internal management of broadcaster.
- SLC 7 (EWS) Emergency Warning System:** his data identify channel used for emergency or alert transmission.

RBDS PI CALCULATOR (only if you are working on US soil)

Rbds PI Calculator

<input style="width: 95%; border: 1px solid #ccc;" type="text" value="CALL Letters"/>	<input style="width: 95%; border: 1px solid #ccc;" type="text" value="PI Code (Hex)"/>
<input style="width: 40px; height: 20px; background-color: #007bff; color: white; border: none;" type="button" value="Convert"/>	<input style="width: 40px; height: 20px; background-color: #007bff; color: white; border: none;" type="button" value="Convert"/>

CALL Letters: write the desired CALL Letters in this field, then click **Convert**. You will read the converted hexadecimal value in **PI Code (Ex)**.

PI Code (Hex): write the desired hexadecimal PI Code in this field. Then click **Convert**. You will read the converted value in **CALL Letters**.

5.3.3.3 UECP MAIN AF

Main Network Editing Controls

Main Network Editing Controls

<input style="width: 95%; border: 1px solid #ccc;" type="text" value="Editing Dataset Index"/>	<input style="width: 95%; border: 1px solid #ccc;" type="text" value="Editing Program Service"/>
<input style="width: 95%; border: 1px solid #ccc;" type="text" value="DSN 1"/>	<input style="width: 95%; border: 1px solid #ccc;" type="text" value="Main PS"/>

Editing Dataset Index: decide which Main **AF List (alternative frequencies)** you want to edit, select the related **DSN (Dataset Number)**.

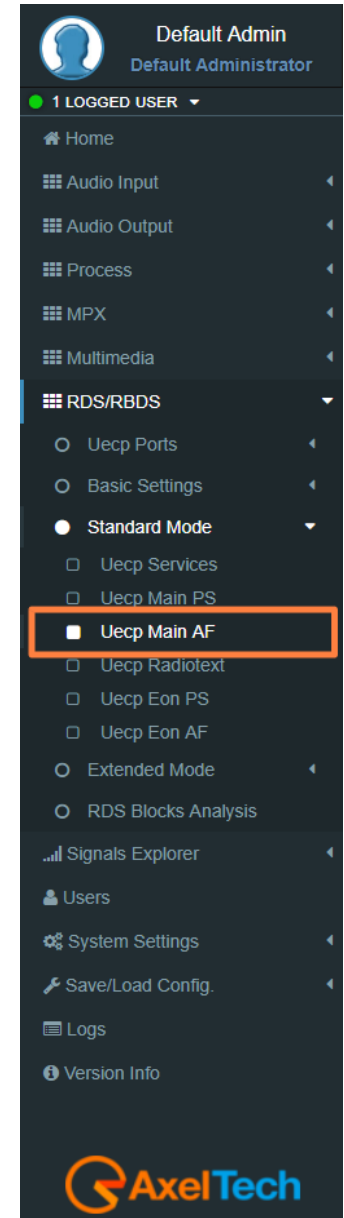

Editing Program Service: You will see this parameter also in **UECP, EON, AF**. Here the parameter is not selectable because this is **AF** of the **MAIN Program Service**.

Alternative Frequencies

If the broadcasting radio station has more than one transmitter in its reaching area then mobile radio listeners can listen to the radio without interruption by the usage of radio receivers auto frequency shifting feature with the support of **RDS Alternative Frequency** feature of the transmitter. This application can be used if the radio receivers enable **AF** support.

Radio X	Transmitter A	88.5 MHz
	Transmitter B	90.7 Mhz
	Transmitter C	101.8 MHz

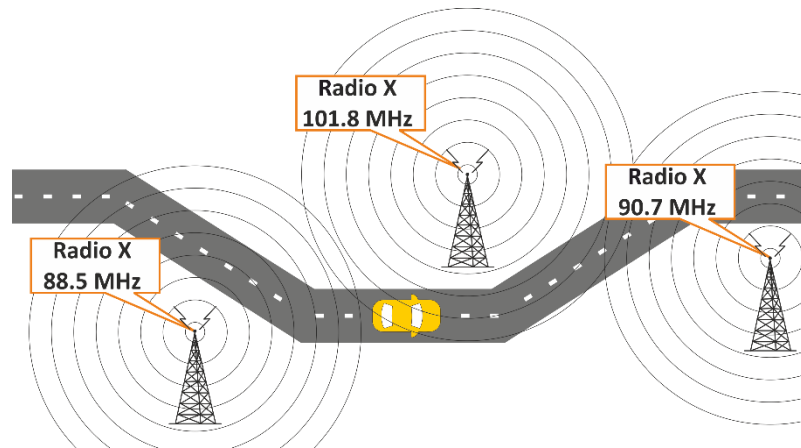

If Radio X Station broadcasts with **RDS AF** feature, and if **AF** feature of the radio receiver of the moving vehicle is enabled then the listener can listen continuously to that radio station without the need to change the frequency. Radio receivers with **RDS** feature automatically choose the strongest signal of the radio station.

AF feature is the ideal system for the vehicles having a long distance to go in order to listen uninterruptedly a radio station.

AF A method transmitted by **OA RDS** group can define 25 frequency transmitters of the same radio station.

AF B method can be applied if the number of frequency transmitters exceeds 25 or regional grouping is needed.

In the following list, you can read **AF (alternative frequencies)** list of desired Tuned frequencies.

Alternative Frequencies				
AF Lists				
Lists	Tuned			
(5-B)	90.0	90.1	90.2	90.3 90.4
(5-B)	91.2	92.4	92.5	100.3 100.6
(2-B)	88.5	88.6		

You see the list of Tuned frequencies with their own **AF** list. **Black AF** are universal. **Blue AF** are regional. click on



to add a new row with **AF** list or click on an existing row to edit it. The following mask will be enabled:

Method	Tuned	AF List
A	100.0	101.0, 102.0, 103.0, 104.0, 105.0

Method: decide between **A/B**. The **B** method allows you to specify also the regionality of the **AF**.

Tuned Freq: here the Main Tuned Freq.

AF List: in this list you see different alternative frequencies separated by a comma (,) and space. If you want to specify that 90.2 frequency is regional. Type **90.2r**.

Add: click on add to confirm parameters and to add them in rows.

Remove: click on a row that you want to delete and click on remove

Update: select a row that you want to edit, change parameters and click **Update** to save changes.

The screenshot shows a sidebar menu for 'Default Admin'. The menu items include: Home, Audio Input, Audio Output, Process, MPX, Multimedia, RDS/RBDS (expanded), Uecp Ports, Basic Settings, Standard Mode (expanded), Uecp Services, Uecp Main PS, **Uecp Main AF** (highlighted), Uecp Radiotext, Uecp Eon PS, Uecp Eon AF, Extended Mode, RDS Blocks Analysis, Signals Explorer, Users, System Settings, Save/Load Config., Logs, and Version Info.

5.3.3.4 UECP RADIOTEXT

Main Network Editing Controls

Main Network Editing Controls

Editing Dataset Index DSN 1	Editing Program Service Main PS
--------------------------------	------------------------------------

Editing Dataset Index: decide which RadioText you want to edit, select the related **DSN (Dataset Number)**.

Editing Program Service: Here the Program Service is not selectable because this is **AF** of the MAIN Program.

Radiotext

Most **RDS** radios can receive short messages which might include information about the presenter, station or programme you are listening to. The information will usually scroll across the display on a home tuner, but this could be distracting to a driver in a car, so the **RadioTEXT** message in a car **hi-fi** does not scroll.

This refers to text transmissions coded, primarily addressed to consumer home receivers, which would be equipped with suitable display facilities.

RT Syntax: From the combo *Reps* choose the number of desired **repetitions** of RT message before system goes on next RT message in the buffer. Choose **A/B** Flag from the combo. If **A/B** Flag is **On** when **RT** is broadcasted, the system tells to receiver to wipe out display buffer before the incoming **RT** is shown. At last write down **RT** message. It can be up to **64 chars** long. Remember: you can program up to **32 radiotext** messages per Dataset.

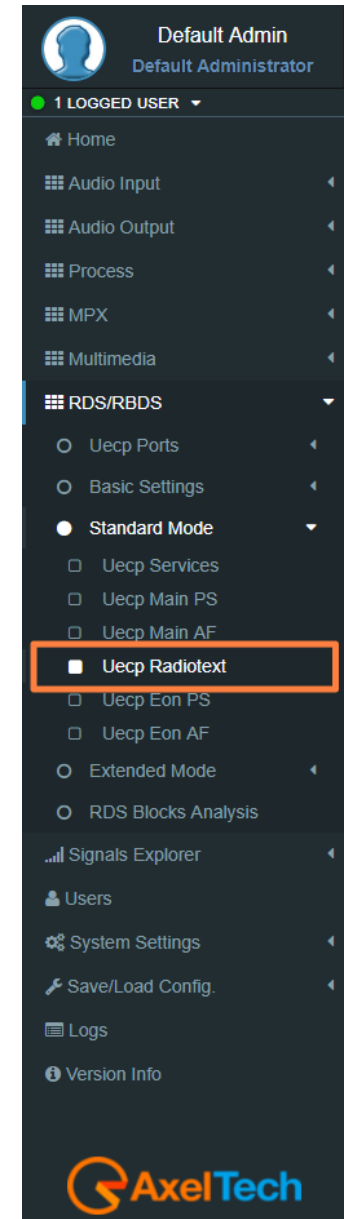

The text can be up to **64** characters long. if your text more than **64** characters you will get an error message. Watch the next figure.

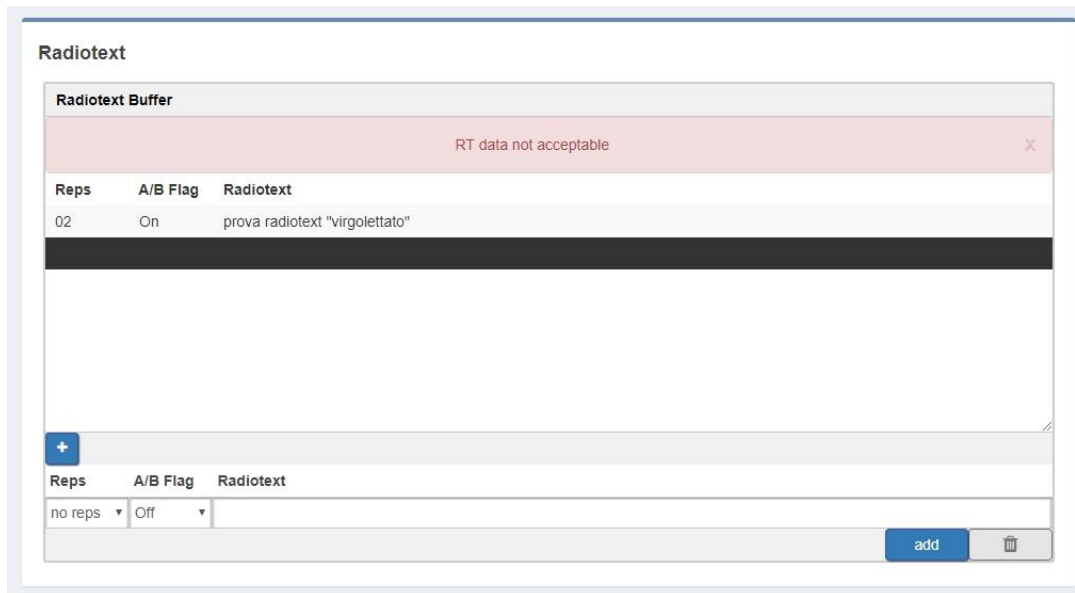

Reps: number of radiotext message repetitions

A/B Flag: The **A/B flag** is an important part of the proper **radiotext** transmission. is used to detect if a screen clear is requested. This flag is used to signal the receiver when a new text message is transmitted. When the receiver detects a change in the **A/B flag** state, the **radiotext** receiver buffer will be cleared, preventing the possibility of a mixture of old and new text messages being displayed on the receiver. In conclusion, the **A/B flag** should be enabled when multiple **RT (RadioText)** messages are scheduled, while it can be disabled in the event of a fixed **RT (RadioText)** broadcasting.

RadioText: RadioText message.

Add: after the new message creation clicks on send to start the RadioText transmission.

Remove: Deletes the selected RadioText message

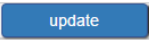
Update: , by selecting an existing RadioText row you can change it. To save new settings click on this button.

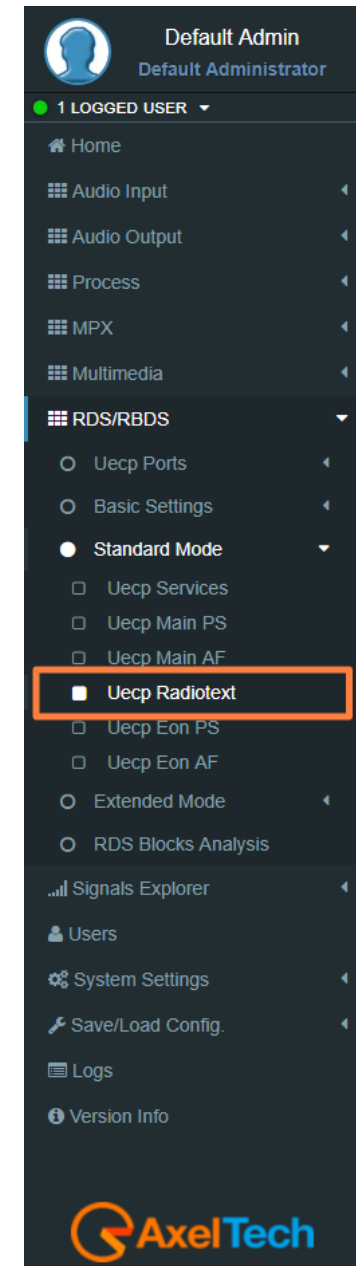

5.3.3.1 UECP EON PS

EON PS This feature can be used to update the **PS (Program Service)** information stored in a receiver about program services.

EON Program Service

Eon Program Service

<div style="border: 1px solid #ccc; padding: 2px;"> Editing Dataset Index DSN 1 </div>	<div style="border: 1px solid #ccc; padding: 2px;"> Editing Program Service Eon 1 PS </div>
--	---

Editing Dataset Index: decide which **Eon PS(Program Service)** you want to edit, select the related DSN (Dataset Number).

Editing Program Service: You will see this parameter also in **UECP, Eon, AF**. you can select between 10 different **EON Program Services**.

EON Basic Settings

Eon Basic Settings

<div style="border: 1px solid #ccc; padding: 2px;"> PI 5001 </div>	<div style="border: 1px solid #ccc; padding: 2px;"> PS NETWRK01 </div>	
<div style="border: 1px solid #ccc; padding: 2px;"> TP Off </div>	<div style="border: 1px solid #ccc; padding: 2px;"> TA Off </div>	
<div style="border: 1px solid #ccc; padding: 2px;"> PTY No Program Type </div>		
<div style="border: 1px solid #ccc; padding: 2px;"> PIN Day 0 </div>	<div style="border: 1px solid #ccc; padding: 2px;"> PIN Hour 0 </div>	<div style="border: 1px solid #ccc; padding: 2px;"> PIN Minute 0 </div>

PI(Program Identification): type the PI Code.

PS(Program Station): type the Program Station Name.

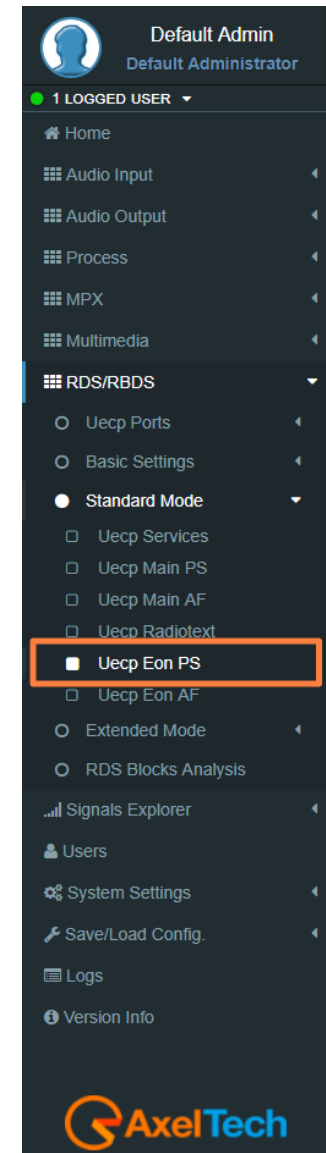

TP(Traffic Program): On/Off

TA(Traffic Announcement): On/Off

PTY: a selectable value between (Pop Music, Rock Music, Culture, Science...).

PTYN: type a desired description for the program.

PIN Day: if you want to schedule a special PTY insert here the month day. From 01 to 31.

PIN Hour: if you want to schedule a special PTY insert here the desired hour (HH). Possible. From 00 to 23.

PIN Minute: if you want to schedule a special PTY insert here the desired minute (MM). From 00 to 59.

Music/Speech: select here if you have a Music program or a Speech program.

Decoder Information: select the audio decoder information.

Eon Linkage

Linkage information provides the means by which several programme services, each characterised by its own **PI** code, may be treated by a receiver as a single service during times a common programme is carried. During such times each program service retains its unique identity, i.e. the programme service must keep its designated **PI** code and its **AF (Alternative Frequency)** list(s), but may change programme related features such as **PS, PTY, RT, TP** and **TA** to reflect the common program.

Linkage information is conveyed in the following four data elements:

Eon Linkage

<div style="border: 1px solid #ccc; padding: 2px;">LA</div> <div style="border: 1px solid #ccc; padding: 2px;">Off ▼</div>	<div style="border: 1px solid #ccc; padding: 2px;">EG</div> <div style="border: 1px solid #ccc; padding: 2px;">Off ▼</div>	<div style="border: 1px solid #ccc; padding: 2px;">ILS</div> <div style="border: 1px solid #ccc; padding: 2px;">Off ▼</div>	<div style="border: 1px solid #ccc; padding: 2px;">LSN</div> <div style="border: 1px solid #ccc; padding: 2px;">000</div>
--	--	---	---

LA: linkage actuator.

EG: extended generic index.

ILS: international linkage standard.

LSN: linkage set number.

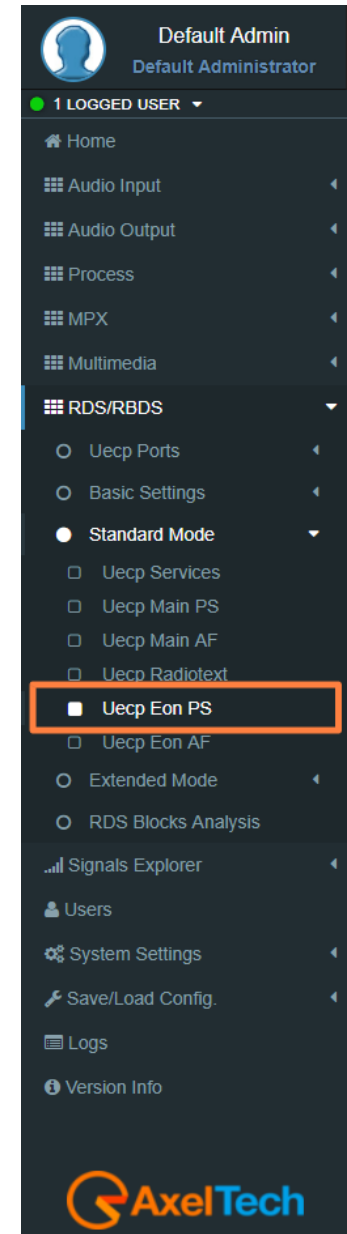

5.3.3.2 UECP EON AF

EON (Enhanced Other Networks Information) makes it possible to transmit information from other stations. This could be used by a radio station, which doesn't offer street traffic program content. If an alternative radio station with **TP (traffic program)** content is available, the tuner temporary switches automatically to the other station during traffic program announcements.

Eon Editing Controls

Eon Editing Controls

Editing Dataset Index

DSN 1

Editing Program Service

Eon 1 PS

Editing Dataset Index: decide which **EON AF** (alternative frequencies) you want to edit, select the related **DSN** (Dataset Number).

Editing Program Service: You will see this parameter also in **UECP Main AF**, you can select between 10 different **EON** Program Services.

EON Alternative Frequencies

In the following list, you can read EON AF (alternative frequencies) list of desired Tuned frequencies.

Eon Alternative Frequencies

Eon AF Lists		
Lists	Tuned	
(4-A)	87.9	91.6 93.5 95.9

+

Method	Tuned Freq.	AF List
A		

add
✖

Default Admin

Default Administrator

1 LOGGED USER ▾

- Home
- Audio Input
- Audio Output
- Process
- MPX
- Multimedia
- RDS/RBDS ▾**
 - Uecp Ports
 - Basic Settings
 - Standard Mode ▾**
 - Uecp Services
 - Uecp Main PS
 - Uecp Main AF
 - Uecp Radiotext
 - Uecp Eon PS
 - Uecp Eon AF**
 - Extended Mode
 - RDS Blocks Analysis
- Signals Explorer
- Users
- System Settings
- Save/Load Config.
- Logs
- Version Info

+		
Method	Tuned	AF List
A	87.9	91.6, 93.5, 95.9

Method: decide between **A, Freq Map 1, Freq Map 2, Freq Map 3.**

Tuned Freq: here the Main Tuned Freq.

AF List: in this list, you see different alternative frequencies.

Add: click on add to confirm parameters and to add them in rows.

Remove: click on a row that you want to delete and click on remove

Update: select a row that you want to edit, change parameters and click **Update** to save changes.

Default Admin
Default Administrator

1 LOGGED USER

- Home
- Audio Input
- Audio Output
- Process
- MPX
- Multimedia
- RDS/RBDS**
 - Uecp Ports
 - Basic Settings
 - Standard Mode**
 - Uecp Services
 - Uecp Main PS
 - Uecp Main AF
 - Uecp Radiotext
 - Uecp Eon PS
 - Uecp Eon AF**
 - Extended Mode
 - RDS Blocks Analysis
- Signals Explorer
- Users
- System Settings
- Save/Load Config.
- Logs
- Version Info

5.3.4 EXTENDED MODE

5.3.4.1 EXTENDED DATASET

Extended Dataset is a special section useful to enable **RDS/RBDS** Features without the using of **UECP** standard.

Dataset Mode

Dataset Operative Mode

UECP Compatible: (the Dataset rules are those defined in **UECP Services** section). In this case, the Extended Source is dis-active.

Extended Mode: (the Dataset rules could be The *Extend Source>Indexed Dataset* or the *Extended Source>Alternative Dataset* or the *Extended Source>REST Command* or the *SMB/SAMBA Share* explained in following lines.

Extended Source:

1. **Indexed Dataset:** if Dataset Operative Mode > Extended Mode, the Dataset choice works with a special binary code created by **GPI (4,5,6)** Events.

GPI Positive Logic:

0 = No GPI event 1 = GPI event Red number = Aired Dataset

GPI Negative Logic:

1 = No GPI event 0 = GPI event Red number = Aired Dataset

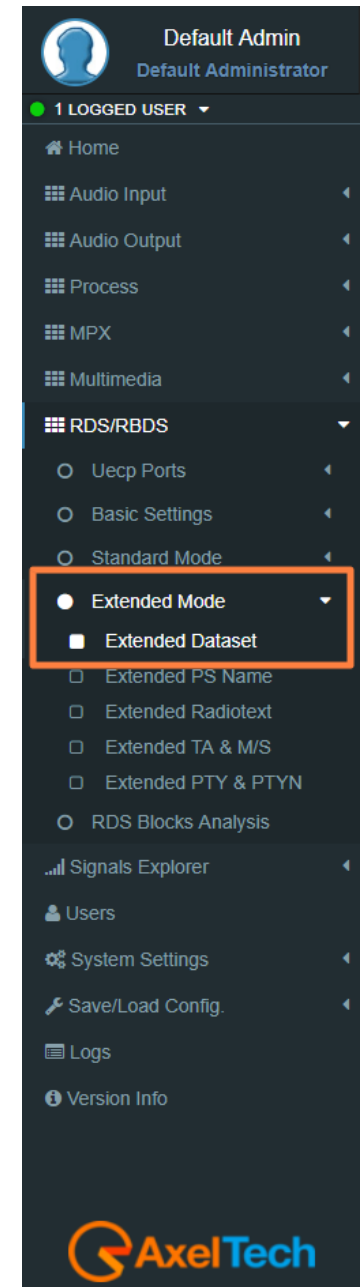

GPI 6	GPI 5	GPI 4	DATASET
0	0	0	1
0	0	1	2
0	1	0	3
0	1	1	4
1	0	0	5
1	0	1	6
1	1	0	7
1	1	1	8

- Alternative Dataset:** if *Dataset Operative Mode > Extended Mode* you can write a Dataset in *Alternative Mode > Alternative Dataset*.
- REST Command:** if Dataset Operative Mode > Extended Mode the dataset will be chosen by REST command.
- SMB/SAMBA Share:** if *Dataset Operative Mode > Extended Mode* the dataset will be chosen by *SMB/SAMBA* server.

Alternative Mode

Alternative Mode

Alternative Dataset

8

Alternative Dataset On

GPI 1 Event

Alternative Dataset: Select between available Datasets the one that will be aired in the following case: *Dataset Operative Mode > Extended Mode* and *Extended Source>Alternative Dataset*.

Active Dataset On: *Dataset Operative Mode > Extended Mode* and *Extended Source >Alternative Dataset*. If Select the **GPI** that actives.

the **Dataset** in the specified **GPI** Event. The control does not work if the related **GPI Event** is masked.

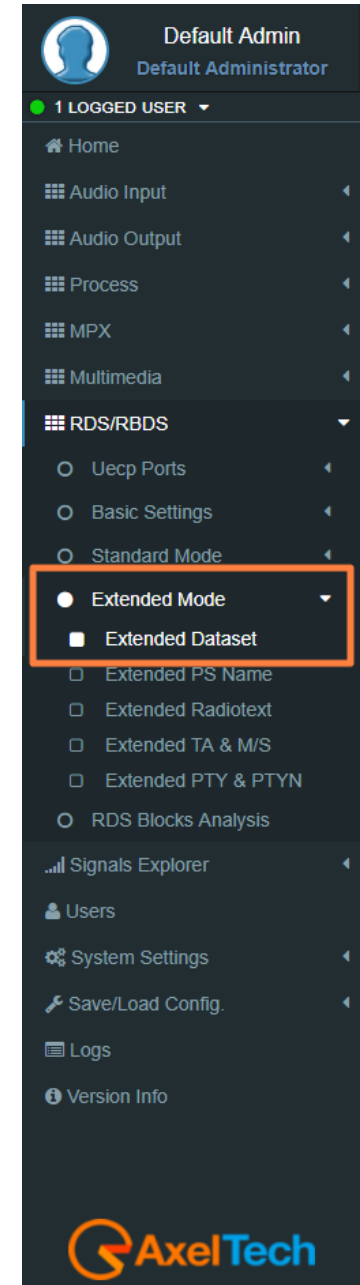

5.3.4.2 EXTENDED PS NAME

PSN Mode

PSN Extended Source: When the Extended PSN Source is on **Aux1 Mpx Changeover Filtered Rebroadcasting Rds Decoder** the Program Service can be driven by **Aux1 MPX signal**.

By selecting the Mpx Changeover Source **A/B** rebroadcasting filters the user can choose this source for the Extended PS.

PSN Operative Mode:

UECP Compatible (the aired PSN is that defined in **UECP Main PS** section).

Extended Mode the aired PSN is the one defined by REST Command or the one defined in the below section Extended PSN Test.

Extended PSN Source: *REST Command, SMB/SAMBA Share, ASCII Parser on UDP Port, ASCII Parser on UDP Port, ASCII Parser on MIB OID, Static Text, Aux1 Mpx Changeover Filtered Rebroadcasting Rds Decoder.*

Extended PSN Buffer Mode: Scrolling

Extended PSN Scrolling Speed: Scrolling speed. Choose between Fastest, Fast, Normal, Slow, Slowest.

Extended PSN Scrolling Steps: Scrolling steps, the number of character scrolling step. From 1 to 8.

Extended PSN Auto Return Mode:

Disabled (there is the PSN repetition)

After 1 Loop (After 1 loop the PSN repetition stops)

After 2 Loops (After 2 loops the PSN repetition stops)

After 3 Loops (After 3 loops the repetition stops)

After 4 Loops (After 4 loops the repetition stops)

After 5 Loops (After 5 loops the repetition stops).

Extended PSN Test

PSN Name: Type here the desired extended PS Name. Then click **SEND** to air it.

Static PSN Text

The user can choose Static Text as **Extended PSN Source**.

Any text written here will be broadcasted as extended PS Name without need any external input.

5.3.4.3 EXTENDED RADIOTEXT

Radiotext Mode

RT Operative Mode:

UECP Compatible (the aired RadioText is that defined in **UECP Radiotext** section).

Extended Mode the aired Radiotext is the one defined by the REST Command or the value will be the one defined in the below section *Extended RT Test*.

RT Extended Source: *REST Command, SMB/SAMBA Share, ASCII Parser on UDP Port, ASCII Parser on UDP Port, ASCII Parser on MIB OID, Static Text, Aux1 Mpx Changeover Filtered Rebroadcasting Rds Decoder.*

When the **Extended RT Source** is on **Aux1 Mpx Changeover Filtered Rebroadcasting Rds Decoder** the Radiotext can be driven by **Aux1 MPX** signal. By selecting the **Mpx Changeover Source A/B** rebroadcasting filters the user can choose this source for the **Extended RT**.

Auto-generated RT+: RT+ Service will be automatically generated using every tagged data available. Important: this service requires 3A and 12A groups in the group sequence list (in Standard Mode - Uecp Services page).

Extended RT Auto Return Time: off, 10 sec – 190 sec.

If it is not off, it returns to the **UECP** buffer if no new data arrives in the selected time.

Note: Sending the same Radiotext within the pre-set time is not accepted as a valid event to prevent the car from returning.

Extended RT Test

Extended RT Test

Radio Text Edit

Radio Text Edit: Type here the desired extended Radiotext. Then click **SEND** to air it.

5.3.4.4 EXTENDED TA & M/S

M/S Mode

M/S Mode

M/S Operative Mode

Uecp Compatible

M/S Extended Source

GPI 1 Event

M/S Operative Mode:

UECP Compatible (the aired Music/Speech value is that defined in **UECP Main PS** section).

Extended Mode the aired Music/Speech value is the one defined by GPI, or by REST Command or the value will be the one defined in the below section **Extended M/S & TA Test** section.

M/S Extended Source:

GPI (1,2,3,4,5,6) Event:

GPI EVENT NOT DETECTED = MUSIC

GPI EVENT DETECTED = SPEECH

REST Command: you can decide if Music or Speech by REST command or by the below **Extended M/S & TA Test** section.

SMB/SAMBA Share: you can decide if the Music or Speech by the payout XML File.

Text Announcement Mode

Text Announcement Mode

TA Operative Mode

Uecp Compatible

TA Extended Source

GPI 1 Event

Default Admin
Default Administrator

1 LOGGED USER ▾

- Home
- Audio Input
- Audio Output
- Process
- MPX
- Multimedia
- RDS/RBDS ▾
 - Uecp Ports
 - Basic Settings
 - Standard Mode
 - Extended Mode ▾
 - Extended Dataset
 - Extended PS Name
 - Extended Radiotext
 - Extended TA & M/S
 - Extended PTY & PTYN
 - RDS Blocks Analysis
- Signals Explorer
- Users
- System Settings
- Save/Load Config.
- Logs
- Version Info

TA Operative Mode:

UECP Compatible (the aired TA on/off value is that defined in **UECP Main PS** section).

Extended Mode (the aired Music/Speech value is the one defined by GPI, or by REST Command or the value will be the one defined in the below section **Extended M/S & TA Test** section).

TA Extended Source:

GPI (1,2,3,4,5,6) Event:

GPI EVENT NOT DETECTED = TA OFF

GPI EVENT DETECTED = TA ON

REST Command: you can decide if TA ON or TA OFF by REST command or by the below **Extended M/S & TA Test** section.

SMB/SAMBA Share: you can decide if TA ON or TA OFF by the payout XML File.

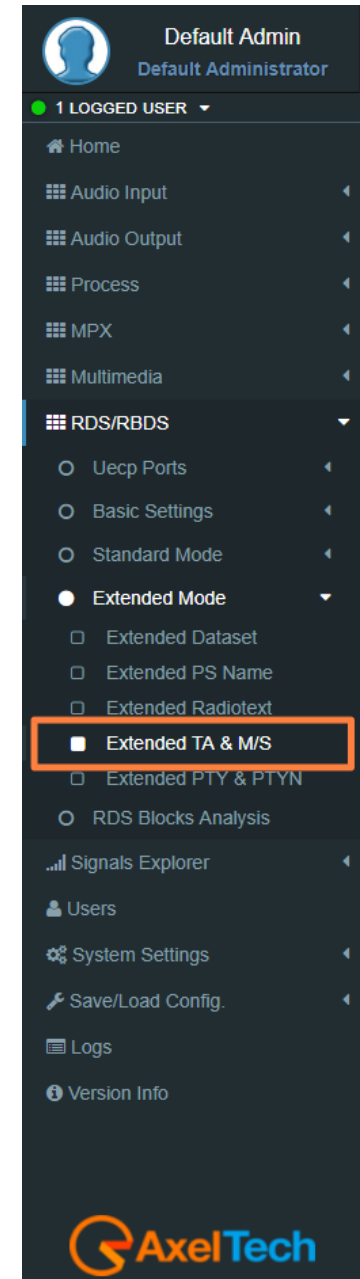

Extended M/S & TA REST Test

Extended M/S & TA REST Test

<div style="border: 1px solid #ccc; padding: 2px;"> <p>Music/Speech</p> <p>Speech</p> </div>	<div style="border: 1px solid #ccc; padding: 2px;"> <p>Traffic Announcement</p> <p>Off</p> </div>
--	---

Music/Speech: airs the Music/Speech only If **TA Operative Mode** is in Extended Mode.

Traffic Announcement: airs the Off/On only If **TA Operative Mode** is in Extended Mode.

Eon TA Mode

<div style="border: 1px solid #ccc; padding: 2px;"> <p>Eon TA 1 Operative Mode</p> <p>Extended Mode</p> </div>	<div style="border: 1px solid #ccc; padding: 2px;"> <p>Eon TA 1 Extended Source</p> <p>GPI 1 Event</p> </div>
--	---

For all the lines the logic works as the Text Announcement Mode. The Extended EON TA is editable from **GPI** and **REST Command**. The following example is an example that summarizes all **EON TA**:

EON TA X OPERATIVE MODE:

UECP Compatible (the aired EON TA on/off value is that defined in **UECP EON PS** section).

Extended Mode (the aired EON TA on/off value is the one defined by GPI or by REST Command).

EON TA X EXTENDED SOURCE:

GPI (1,2,3,4,5,6) Event:

GPI EVENT NOT DETECTED = EON TA OFF

GPI EVENT DETECTED = EON TA ON

REST Command: you can decide if **TA ON** or **TA OFF** by **REST command**.

5.3.4.5 EXTENDED PTY e PTYN

PTY Mode

PTY Mode

PTY Operative Mode Uecp Compatible	PTY Extended Source REST Command
---------------------------------------	-------------------------------------

PTY Operative Mode:

UECP Compatible (the aired PTY value is that defined in **UECP MAIN PS** section).

Extended Mode: (the aired PTY value is the one defined by **REST Command**).

PTY Extended Source: REST Command or SMB/SAMBA.

PTYN Mode

PTYN Mode

PTYN Operative Mode Uecp Compatible	PTYN Extended Source REST Command
--	--------------------------------------

PTYN Operative Mode:

UECP Compatible (the aired PTYN value is that defined in **UECP MAIN PS** section).

Default Admin
Default Administrator

1 LOGGED USER

- Home
- Audio Input
- Audio Output
- Process
- MPX
- Multimedia
- RDS/RBDS
 - Uecp Ports
 - Basic Settings
 - Standard Mode
 - Extended Mode**
 - Extended Dataset
 - Extended PS Name
 - Extended Radiotext
 - Extended TA & M/S
 - Extended PTY & PTYN**
 - RDS Blocks Analysis
 - Signals Explorer
 - Users
 - System Settings
 - Save/Load Config.
 - Logs
 - Version Info

Extended Mode (the aired PTY value is the one defined by REST Command or by the following section Extended PTYN Test).

PTYN Extended Source: REST Command or SMB/SAMBA.

Extended PTYN Test

Extended PTYN Test

PTYN Edit

SEND

PTYN Edit: type here the desired Extended **PTYN** value and then click on **Send**.

5.3.5 RDS BLOCKS ANALYSIS

From the following panel you can read for the statistics related to each transmitted group:

RDS GROUPS STATISTIC



Default Admin
Default Administrator

1 LOGGED USER ▾

- Home
- Audio Input
- Audio Output
- Process
- MPX
- Multimedia
- RDS/RBDS ▾
 - Uecp Ports
 - Basic Settings
 - Standard Mode
 - Extended Mode
 - RDS Blocks Analysis
- Signals Explorer
- Users
- System Settings
- Save/Load Config.
- Logs
- Version Info

5.4 USERS

In the Administration section, you can read, manage all the users and you can set their access permissions to the device. This section can be managed only by the Admin users.

Users List

Axel Technology - Administrator

Tester 1 - Super User



Selected user

Non selected user

remove button



confirm the selected user removal



add a new User

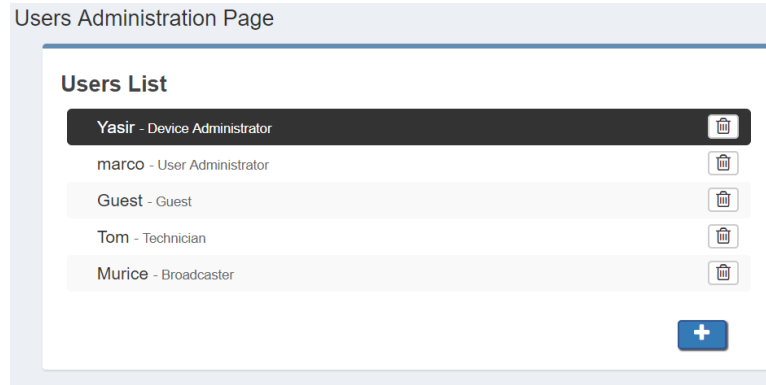

User Details (*user name*)

Full Name: User Name

E-Mail: user email

User Class: user class, here you can decide user permissions.



Discard Changes from the selected user



Change the password for the selected user



Save Changes for the selected user

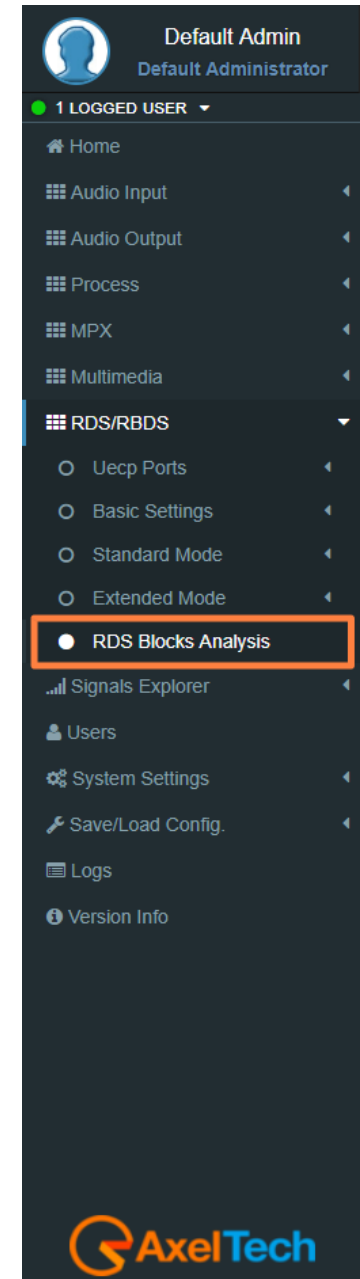
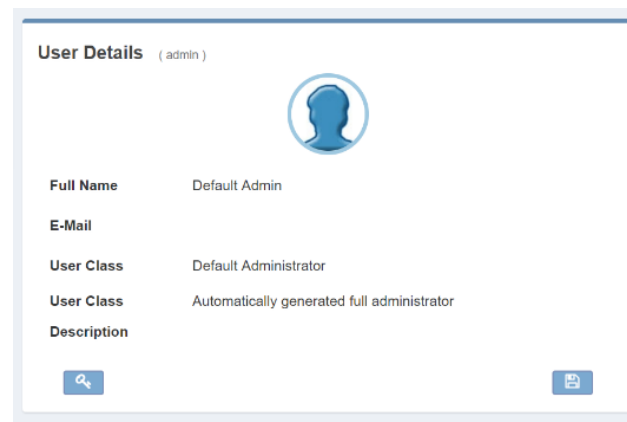

5.4.1 USER CLASS – USER RIGHTS TO LOGIN THE SYSTEM

Full Administrator

The Full Administrator manages all user profiles, accesses all pages (except the calibration).

Default Administrator (Default User): The default administrator is the default user of the device, it is under the Full Administrator category, but it has fixed access credentials (user: admin – pwd: admin). This user is visible only when the system has no other Full Administrators.

User Administrator

User Administrator. It manages the profiles of all users.

Device Administrator

Non-administrator user that accesses all pages (it does not access to administration, calibration and some of the product nameplate data).

Technician

The technician is the one who controls all the hardware parameters of the machine and the control of information pages.

Broadcaster

It has full control only on information management pages and on the audio signal.

Guest/Reader

Guest accesses anywhere without being able to edit any parameter.

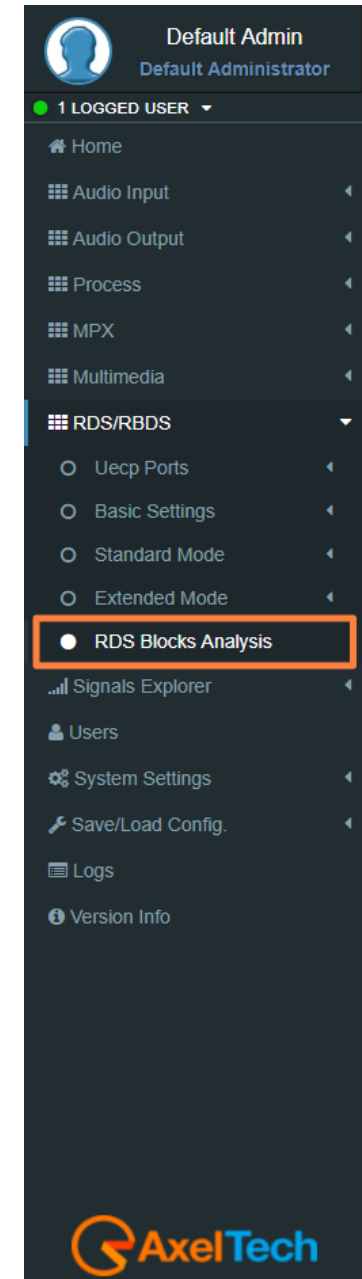

Below, a summary table with the list of product pages and access rights for each type of use:

Legend

RW: full access (read/write)

R: read-only user

H: hidid page

Page	Full Admin	User Admin	Device Admin	Technician	Broadcaster	Guest
Home	R	R	R	R	R	R
General Setup	RW	R	RW	RW	R	R
Network	RW	R	RW	RW	R	R
NTP	RW	R	RW	RW	R	R
SNMP	RW	R	RW	RW	R	R
SMTP	RW	R	RW	RW	R	R
GPIO	RW	R	RW	RW	R	R
GPS	RW	R	RW	RW	R	R
Updates	RW	R	RW	R	R	R
Device Management	RW	R	RW	R	R	R
SD Card Utilities	RW	R	RW	R	R	R
Administration	RW	RW	H	H	H	H
Logs	RW	RW	RW	RW	RW	R
Logs (Debug)	H	H	H	H	H	H
Configuration	RW	R	RW	RW	RW	R
Quick Rds Setup	RW	R	RW	R	R	R
Serial Ports	RW	R	RW	RW	R	R
Tcp/Ip Ports	RW	R	RW	RW	R	R
UDP/SNMP Ports	RW	R	RW	RW	R	R
Uecp Addressing	RW	R	RW	RW	R	R
Rds Settings	RW	R	RW	RW	R	R
Real Time Clock	RW	R	RW	RW	R	R
Uecp Services	RW	R	RW	R	RW	R
Uecp Main PS	RW	R	RW	R	RW	R
Uecp Main AF	RW	R	RW	R	RW	R
Uecp Radiotext	RW	R	RW	R	RW	R
Uecp Eon PS	RW	R	RW	R	RW	R
Uecp Eon AF	RW	R	RW	R	RW	R
Extended Dataset	RW	R	RW	R	RW	R
Extended PS Name	RW	R	RW	R	RW	R
Extended Radiotext	RW	R	RW	R	RW	R
Extended TA & M/S	RW	R	RW	R	RW	R

Extended Pty&Ptn	RW	R	RW	R	RW	R
RDS Blocks Analysis	R	R	R	R	R	R
Audio Input Sources: Analogic	RW	R	RW	RW	RW	R
Audio Input Sources: Digital	RW	R	RW	RW	RW	R
Audio Input Sources: Multimedia	RW	R	RW	RW	RW	R
Audio Input Sources: MPX Decoder	RW	R	RW	RW	RW	R
Audio Input Sources: Audio Generator	RW	R	RW	RW	RW	R
Audio Input Sources: Output Monitor	RW	R	RW	RW	RW	R
Audio Input: Changeover	RW	R	RW	RW	RW	R
Audio Input:Audio Analysis	RW	R	RW	RW	RW	R
Internal MPX Encoder	RW	R	RW	RW	RW	R
MPX Changeover: Delay	RW	R	RW	RW	RW	R
MPX Changeover: Source A	RW	R	RW	RW	RW	R
MPX Changeover: Source B	RW	R	RW	RW	RW	R
MPX Outputs	RW	R	RW	RW	RW	R
MPX Analysis	RW	R	RW	RW	RW	R
Multimedia Streamer: Encoder	RW	R	RW	RW	RW	R
Multimedia Streamer: Decoder	RW	R	RW	RW	RW	R
Multimedia Output	RW	R	RW	RW	RW	R

5.4.2 ADDING A NEW USER

To add a New User read the following steps:

1. Click on Add a New User button
2. Type in the following fields the new user details:

User Name: New User name

Full Name: New User full name

E-Mail: New User email address

User Class: Select here the new user class

Password: New User Password

Password (Confirm): Password confirmation

3. click on to discard last changes or click on to save for them.

New User Details

User Name

Full Name

E-Mail

User Class

Password

Password (Confirm)

5.4.3 REMOVING AN EXISTING USER.

To remove an Existing User read the following steps:

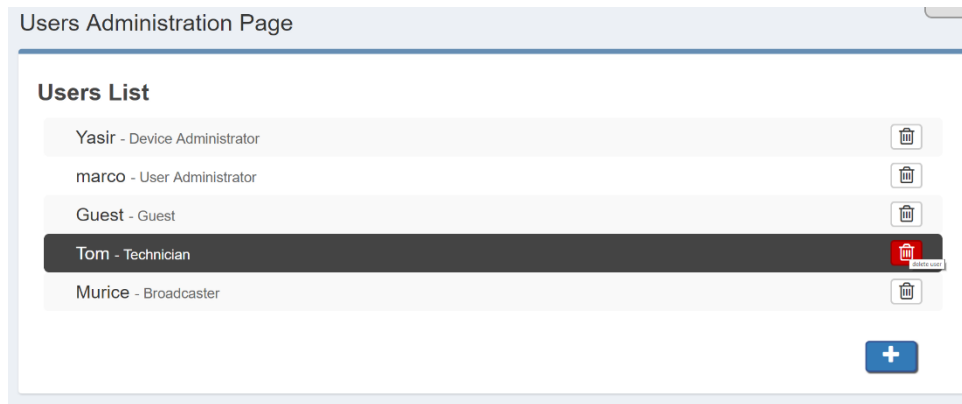

1. Move the mouse to the desired user.
2. Click on the delete button.
3. In the following mask Click on to exit from the user deletion or click on to confirm his deletion.

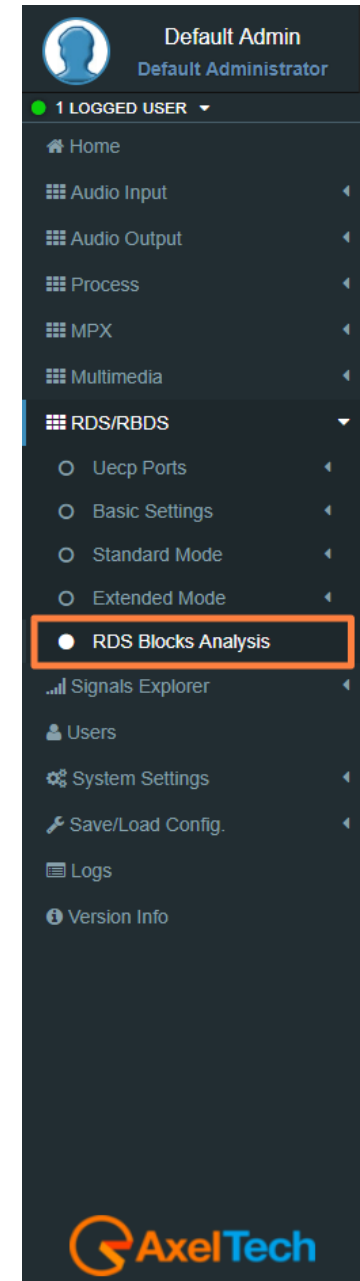
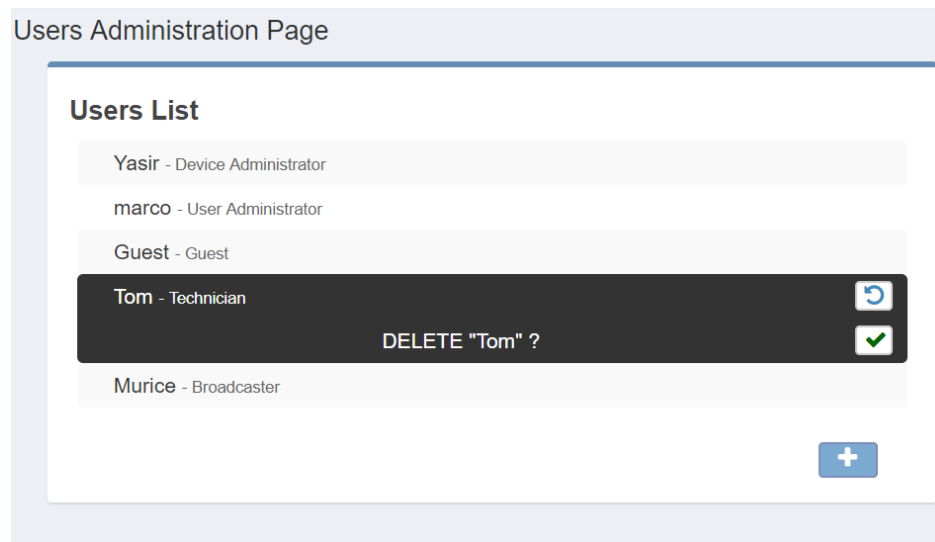

5.5 SYSTEM SETTINGS

By clicking on the setup you can see all the available setup subpages as shown in the following picture.

5.5.1 GENERAL SETUP

In [Setup > General Setup](#) you have different general parameters to start with the device setup:

Target References

Target References

Host Name Prefix FALCONX7	Host Name Custom I	Host Name FALCONX7
Target Name Ref. ---	Target Location Ref. ---	Target Operator Ref. ---
Target Web Label _____		

Host Name Prefix: default field with the Product Name. This parameter is unchangeable.

Host Name Custom: customizable parameter. Type here the desired device name. This parameter helps you to recognize the device in your computer network.

Host Name: Host Name Prefix(fixed value) + Host Name Custom.

Target Name Ref.: Type here a desired name for the device.

Target Location Ref.: Type here the device location.

Target Operator Ref.: Type here the Operator name.

Target Web Label: allows customizing the tab of the web browser of the machine.

Note: Web editing is visible only after a page refresh.

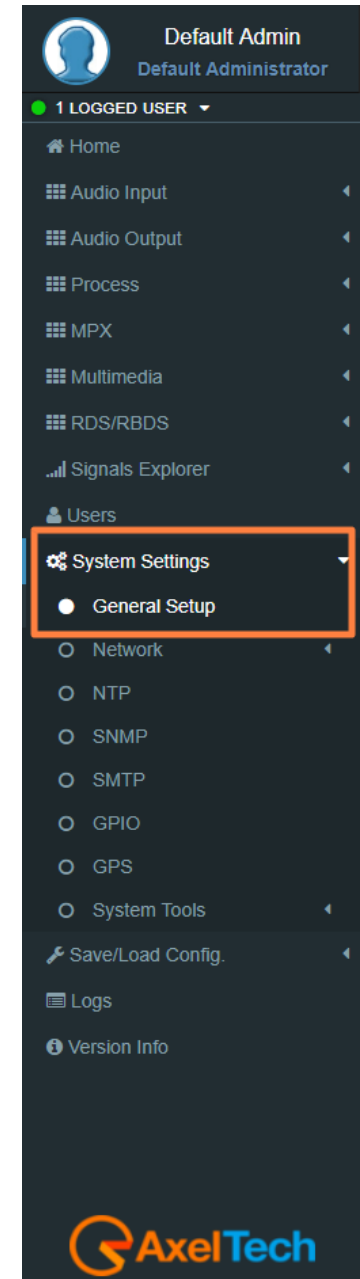
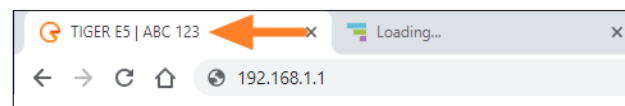
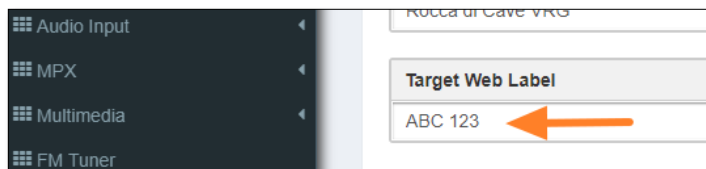

Other Settings

Other Settings

Language English ▼	Http Bandwidth High Bandwidth ▼	Local Time Zone Europe/Rome ▼
------------------------------	---	---

Language: Select here the desired device language.

Http Bandwidth: Select here between GPRS, Low, Normal or High bandwidth.

Local Time Zone: Select from the drop-down menu the desired Time Zone.

REST Settings

REST Settings

<input checked="" type="checkbox"/> Active	Port 5000
--	---------------------

Active: Check/Uncheck this box if you want to activate/deactivate the REST API for the device.

Port: RDS E3 Coder is active on port 5000.

The REST APIs in this device are intended as Extended Mode parameter. To allow the REST APIs to work, we advise you to set also the following parameters in the following ways:

RDS/RBDS > Basic Settings > Rds Settings > Rds General Settings > Rds Global Extended Mode > Enabled

go in ***Rds/Rbds > Extended Mode*** and in the single service you want to enable set:

Dataset Operative Mode = **Extended Mode**

Extended Source = **Rest Command**



Default Admin
Default Administrator

1 LOGGED USER ▼

- Home
- Audio Input
- Audio Output
- Process
- MPX
- Multimedia
- RDS/RBDS
- Signals Explorer
- Users
- System Settings ▼
 - General Setup
 - Network
 - NTP
 - SNMP
 - SMTP
 - GPIO
 - GPS
 - System Tools
- Save/Load Config.
- Logs
- Version Info



The REST interface allows to manage the following EXTENDED MODE parameters:

- Active Dataset;
- Aired Program Service Name;
- Aired Radiotext;
- Aired Program Type;
- Aired Program Type Name;
- Traffic Announcement;
- Music/Speech;
- All 10 EON-TA;

Below are examples of REST API. In the following lines the syntax:

(READ)

http://<PC IP or Url>:5000/REST/send/READ?TOKEN=AX&MOD=RDS&VARNAME=<variable name>

(WRITE)

http:// <PC IP or Url>:5000/REST/send/WRITE?TOKEN=AX&MOD=RDS&VARNAME=<variable name>&VARVALUE=<value to set>

DATASET

(READ)

http://<PC IP or Url>:5000/REST/send/READ?TOKEN=AX&MOD=RDS&VARNAME=DSET_Ext_DYN

(WRITE)

http:// <PC IP or Url>:5000/REST/send/WRITE?TOKEN=AX&MOD=RDS&VARNAME=DSET_Ext_DYN&VARVALUE=x

where x can be 1, 2, 3, 4, 5, 6, 7, 8.

Aired Program Service Name

(READ)

http://<PC IP or Url>:5000/REST/send/READ?TOKEN=AX&MOD=RDS&VARNAME=PSN_Ext_DYN_Local

(WRITE)

http:// <PC IP or Url>:5000/REST/send/WRITE?TOKEN=AX&MOD=RDS&VARNAME=PSN_Ext_DYN_Local&VARVALUE=aaaaaaaa

where *aaaaaaaa* is a string of 64 characters max. The string can be composed by symbols and accented letters.

It is also possible to act on the EXTENDED MODE parameters of the Program Service Name:

Extended PSN Buffer Mode

At the moment it is fixed on *Scrolling*. The variable can only be read. The reference variable is **PSN_Buffer_Mode**.

(READ)

http://<PC IP or Url>:5000/REST/send/READ?TOKEN=AX&MOD=RDS&VARNAME=<PSN_Buffer_Mode>

Extended PSN Scrolling Speed

The reference variable is **PSN_Scrolling_Speed**. It can take the following values:

"Fastest", "Fast", "Normal", "Slow", "Slowest"

(READ)

http://<PC IP or Url>:5000/REST/send/READ?TOKEN=AX&MOD=RDS&VARNAME=<PSN_Scrolling_Speed>

(WRITE)

http:// <PC IP or Url>:5000/REST/send/WRITE?TOKEN=AX&MOD=RDS&VARNAME=<PSN_Scrolling_Speed>&VARVALUE=<Fastest>

Extended PSN Scrolling Steps

The reference variable is PSN_StepMode. It can assume values from 1 to 8 and represents the number of characters that flow each time.

(READ)

http://<PC IP or Url>:5000/REST/send/READ?TOKEN=AX&MOD=RDS&VARNAME=<PSN_Step_Mode>

(WRITE)

http:// <PC IP or Url>:5000/REST/send/WRITE?TOKEN=AX&MOD=RDS&VARNAME=<PSN_Step_Mode>&VARVALUE=<x>

where x can be 1, 2, 3, 4, 5, 6, 7, 8.

Extended PSN Auto Return Mode

The reference variable is **PSN_Return_Mode**. This variable can be the following values:

"Disabled", "After 1 Loop", "After 2 Loops", "After 3 Loops", "After 4 Loops", "After 5 Loops"

and it indicates the behaviour of the writing in the buffer. The Disabled value says that the writing will rotate indefinitely. The other values indicate the number of revolutions of the writing before the buffer is cleaned up and the writing deleted.

(READ)

http://<PC IP or Url>:5000/REST/send/READ?TOKEN=AX&MOD=RDS&VARNAME=<PSN_Return_Mode>

(WRITE)

http:// <PC IP or Url>:5000/REST/send/WRITE?TOKEN=AX&MOD=RDS&VARNAME=<PSN_Return_Mode>&VARVALUE=<After 1 Loop>

Aired Radiotext

(READ)

http://<PC IP or Url>:5000/REST/send/READ?TOKEN=AX&MOD=RDS&VARNAME=RT_Ext_DYN_Local

(WRITE)

http:// <PC IP or Url>:5000/REST/send/WRITE?TOKEN=AX&MOD=RDS&VARNAME=RT_Ext_DYN_Local&VARVALUE=aaaaaaaa

where *aaaaaaaa* is a string of 255 characters long. The string can be composed by symbols and accented letters.

Aired Program Type

(READ)

http://<PC IP or Url >:5000/REST/send/READ?TOKEN=AX&MOD=RDS&VARNAME=PTY_Ext_DYN

(WRITE)

http:// <PC IP or Url>:5000/REST/send/WRITE?TOKEN=AX&MOD=RDS&VARNAME=PTY_Ext_DYN&VARVALUE=x

where x is a value from 0 to 31 which encodes the PTY according to the standard.

Aired Program Type Name

(READ)

http://<PC IP or Url>:5000/REST/send/READ?TOKEN=AX&MOD=RDS&VARNAME=PTYN_Ext_DYN_Local

(WRITE)

http:// <PC IP or Url>:5000/REST/send/WRITE?TOKEN=AX&MOD=RDS&VARNAME=PTYN_Ext_DYN_Local&VARVALUE=aaaaaaaa

where aaaaaaaaa is a string of 8 characters at the max that can contain symbols and accented letters.

Traffic Announcement

(READ)

http://<PC IP or Url >:5000/REST/send/READ?TOKEN=AX&MOD=RDS&VARNAME=TA_Ext_DYN

(WRITE)

http:// <PC IP or Url>:5000/REST/send/WRITE?TOKEN=AX&MOD=RDS&VARNAME=TA_Ext_DYN&VARVALUE=x

where x can be *Off* or *On*.

Music/Speech

(*READ*)

http://<PC IP or Url>:5000/REST/send/READ?TOKEN=AX&MOD=RDS&VARNAME=MS_Ext_DYN

(*WRITE*)

http:// <PC IP or Url>:5000/REST/send/WRITE?TOKEN=AX&MOD=RDS&VARNAME=MS_Ext_DYN&VARVALUE=x

where x can be *Speech* or *Music*.

EON Traffic Announcement

(*READ*)

http://<PC IP or Url>:5000/REST/send/READ?TOKEN=AX&MOD=RDS&VARNAME=EON_TA_n_Ext_DYN

where n can be a number from 1 to 10 (ex: EON_TA_7_DYN).

(*WRITE*)

http:// <PC IP or Url>:5000/REST/send/WRITE?TOKEN=AX&MOD=RDS&VARNAME=EON_TA_n_Ext_DYN &VARVALUE=x

where x can be *Off* or *On*.

SMB/SAMBA Share Settings

SMB Server Message Block. This section helps you to air **TITLE** and **AUTHOR** of the aired song by the DJPRO playout Dalet and with MB Studio. These 2 parameters will be aired via **RDS** directly from our playout software DJPRO in your **RADIOTEXT**. In the following pictures, you can find all the settings.

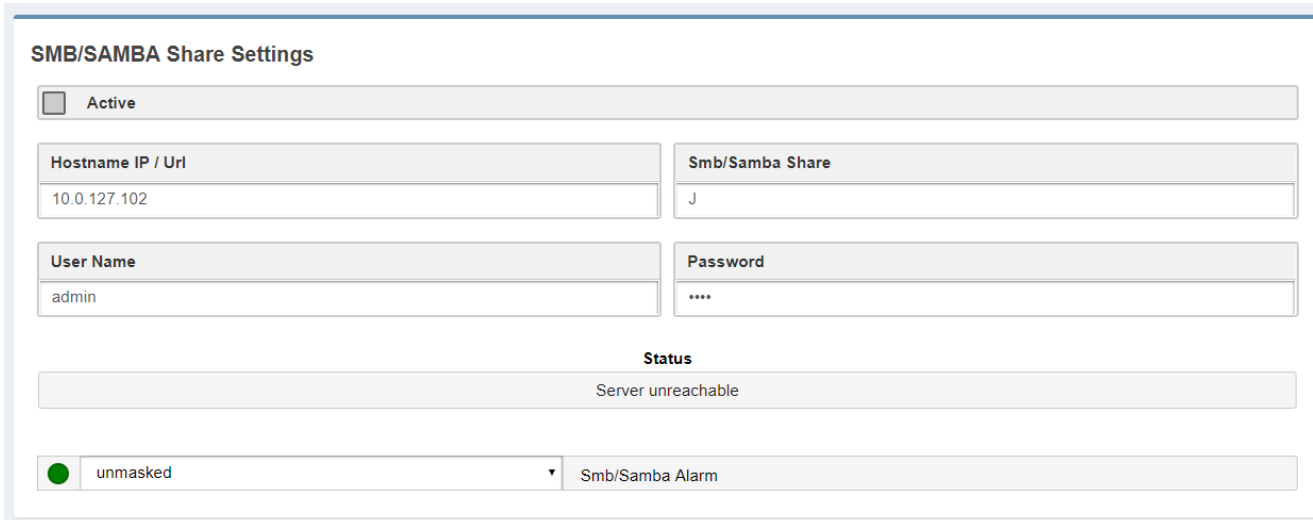

SMB/SAMBA Share Settings

Active

Hostname IP / Url: 10.0.127.102 Smb/Samba Share: J

User Name: admin Password: ****

Status
Server unreachable

unmasked Smb/Samba Alarm

Active: Check/Uncheck this parameter to activate/deactivate the control on the playout folder.

Hostname IP / URL: Type here the IP/URL of the PC where the Playout software writes the (TXT, XML, INI,...) file with the playlist (for example [//192.168.XXX.XXX](#)).

Smb/Samba Share: Type here the shared resource where the XML file is saved (for example: J).

Attention, here it is not possible to write a classic path, but only a shared resource.

User Name: Type here the shared resource Username.

Password: Type here the shared resource Password.

Masked/Unmasked: decide here if you want to mask/unmask the Alarms related to the connectivity with the PC / Shared Resource. If you see SMB/SAMBA Alarms something is wrong with the IP/URL, Smb/Samba Share or USERNAME and PASSWORD.

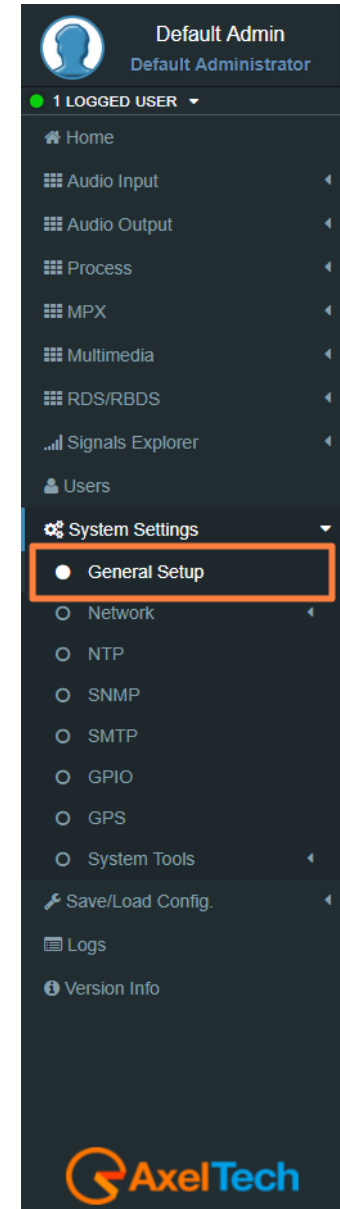

Default Admin
Default Administrator

1 LOGGED USER

- Home
- Audio Input
- Audio Output
- Process
- MPX
- Multimedia
- RDS/RBDS
- Signals Explorer
- Users
- System Settings**
 - General Setup**
 - Network
 - NTP
 - SNMP
 - SMTP
 - GPIO
 - GPS
 - System Tools
- Save/Load Config.
- Logs
- Version Info



DJPRO SAMBA share

In the next image, you can see the **DJPRO** setup area where you can set the **.xml** path.

Go to **Main Menu > Setup ON-AIR Manager > ON AIR > Open Setup > Extern > RDS Settings (IEM)**.

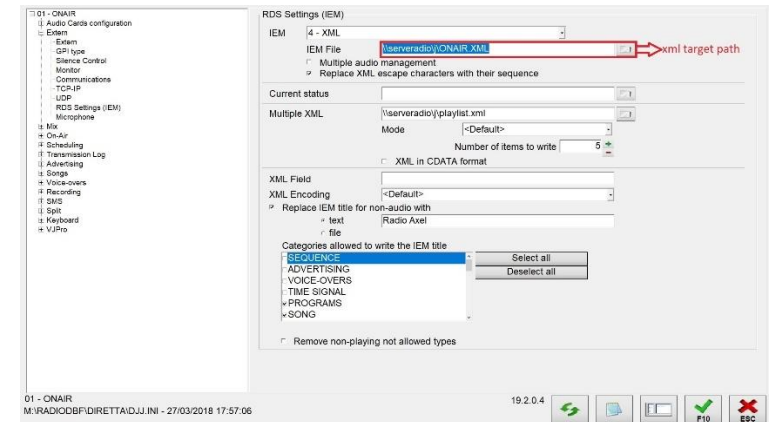

ZARA Studio SAMBA share

This software rigidly generates a **CurrentSong.txt** file containing the file name of the song currently in playlist.

Just select the **SAMBA share** folder as '**Output Folder**'.

Note: Since the software allows the insertion of **TTH** Announcements (time signal, temperature and humidity) the device recognizes the various types and formats the **PS** and the **Radiotext** on the air as a consequence:

Info Type	PS / Radiotext
Song	Title
Time	Time Announcement
Temperature	Temperature Announcement
Humidity	Humidity Announcement

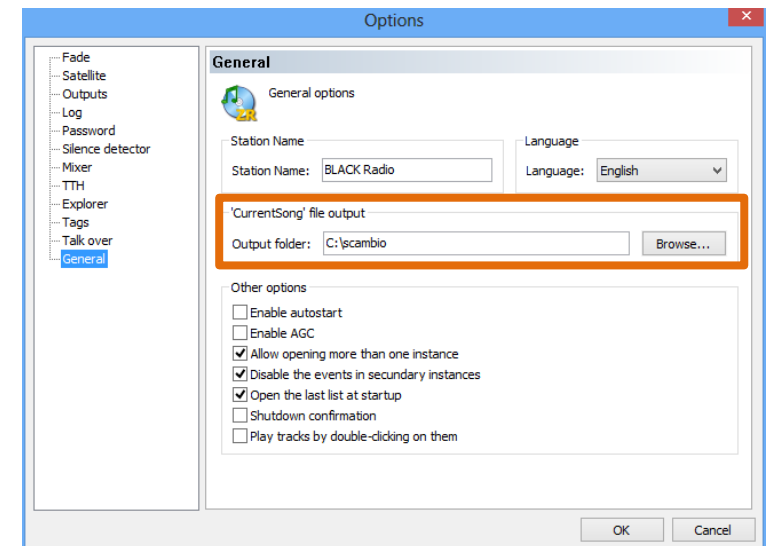

During jingles (Intervals and announcements), there is no content variation in the **CurrentSong.txt** file, so they are not traceable.

If the playlist is interrupted, there is no change in content in the **CurrentSong.txt** file (it remains the last event on air).

Dinesat SAMBA share

This software allows exporting the data of the current playlist both on text files and on an **XML** metadata file.

Our device is able to process only the **XML** data stream, so it will be set on the software to generate a **.xml** file in the **SAMBA share**:

Simply check the '**Enable XML Data**' and select the file to be inserted as a **SAMBA share** in the desired folder. Obviously, the name of the chosen file will be that of the **SAMBA share** to be indicated in the **RDS settings** of our device.

As highlighted by the blue arrow, it is possible to indicate which categories of playlist events end up in the **XML** file (Music, Advertising or Artistic data relating to the song, such as the album of the collection).

In any case, the content of the **XML** file is read by our device to form the **PS** and the **Radiotext** on the air.

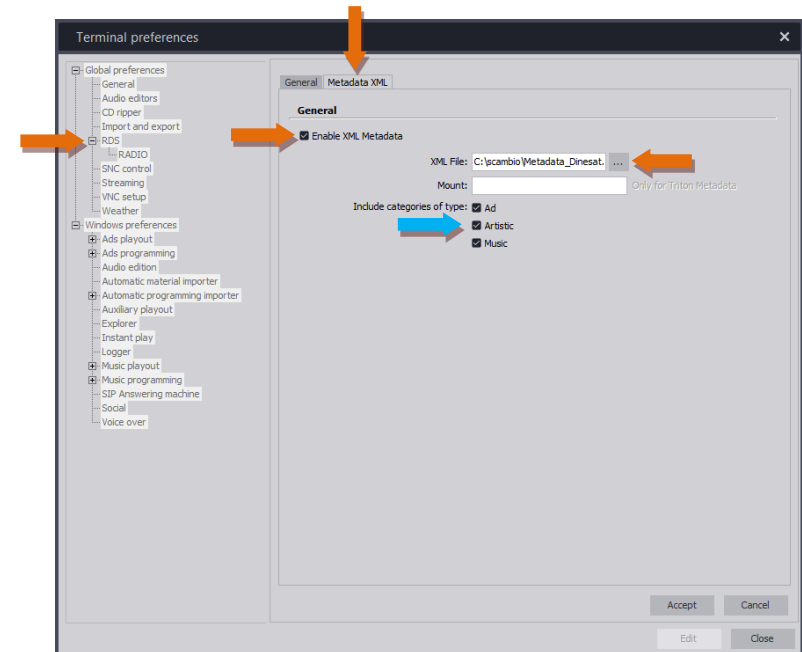

Target Localization

Target Localization

Manual Target Coordinates

Latitude 44.3221	Longitude 11.1300	Marker Baloon Field Bologna
---------------------	----------------------	--------------------------------

Manual Target Coordinates: Check/Uncheck this parameter to activate/deactivate the Manual Target Coordinates insertion.

Latitude: Latitude insertion is activated when **Manual Target Coordinates** is checked. Type here the manual latitude. ” please use the numbers and points as shown in figure ”.

Longitude: Longitude insertion is activated when **Manual Target Coordinates** is checked. Type here the manual longitude. ” please use the numbers and points as shown in figure ”.

Marker Baloon Field: Insert here what you want to read on the map Marker Baloon at the selected coordinates.

Front Panel Display lock

Front Panel Display Secure Lock

Display Lock

Display Lock: By activating this function can prevent access and change setting from front panel.

Manual Target Clock Synchronization

Manual Target Clock Synchronization

Synchronize Target with Client Clock

Synchronize Target with Client Clock: synchronizes the clock with the client pc clock.

5.5.2 NETWORK

In [Setup > Network > eth0](#) you have different parameters to set configurations for the device network connection and addressing:

Mac Address



MacAddress: Here you can read the device Mac Address.

In [General Configuration](#) you can read for all the current network settings.

Network Interface

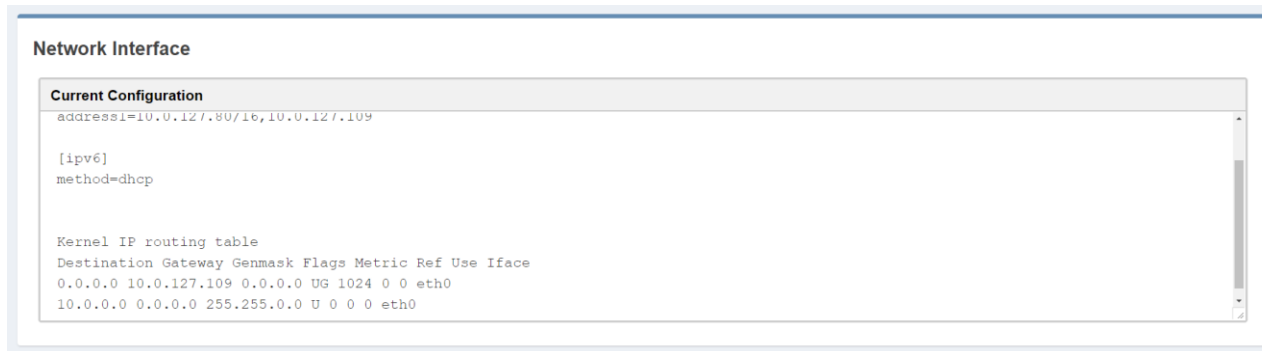

Current Interface: It's a textbox in order to give a possibility to copy all network configuration.

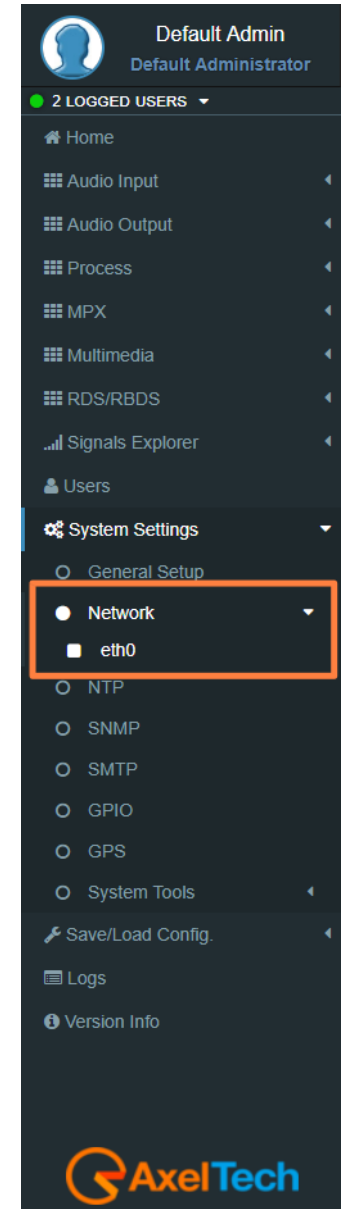

IPv4 Addressing

IPv4 Addressing Method: choose here the Addressing Method. You can choose between Manual or DHCP(auto).

Manual: if you choose Manual you have to insert all IPv4 and DNS IPv4 data.

DHCP(auto): a DHCP (Dynamic Host Configuration Protocol) server dynamically distributes network configuration parameters.

IPv6 Address

IPv6 Addressing Method: choose here the Addressing Method. You can choose between Manual or DHCP(auto).

Manual: if you choose Manual you have to insert all IPv6 and DNS IPv6 data.

DHCP(auto): a DHCP (Dynamic Host Configuration Protocol) server dynamically distributes network configuration parameters.

In the following setting sections you can fill all the desired IP data if you have set Manual Addressing Method:

Primary IPv4

Primary IPv4

Address	10.0.127.80
Subnet Mask	255.255.0.0
Gateway (Default)	10.0.127.100

Additional #1 IPv4

Additional #2 IPv4

Additional #1 IPv4

Address	Subnet Mask
<input type="text"/>	<input type="text"/>

Additional #2 IPv4

Address	Subnet Mask
<input type="text"/>	<input type="text"/>

Default Admin
Default Administrator

2 LOGGED USERS ▾

- Home
- Audio Input
- Audio Output
- Process
- MPX
- Multimedia
- RDS/RBDS
- Signals Explorer
- Users
- System Settings ▾
 - General Setup
 - Network ▾**
 - eth0
 - NTP
 - SNMP
 - SMTP
 - GPIO
 - GPS
 - System Tools
- Save/Load Config.
- Logs
- Version Info

DNS IPv4

DNS IPv4

Primary DNS

Additional #1 DNS

Additional #2 DNS

Enable(Primary DNS IPv4): If it is needed, click on the checkbox to enable a Primary DNS IPv4.

Primary DNS(IPv4): type here the IP of the desired DNS server.

Enable(Additional #1 DNS IPv4): Check it to enable the first additional DNS IPv4 Server.

Additional #1 DNS(IPv4): type the IP of the DNS server.

Enable(Additional #2 DNS IPv4): Check it to enable the second additional DNS IPv4 Server.

Additional #2 DNS(IPv4): type the IP of the DNS server.

DNS IPv6

DNS IPv6

Primary DNS

Additional #1 DNS

Additional #2 DNS

Default Admin
 Default Administrator

2 LOGGED USERS ▾

- Home
- Audio Input
- Audio Output
- Process
- MPX
- Multimedia
- RDS/RBDS
- Signals Explorer
- Users
- System Settings ▾
 - General Setup
 - Network ▾
 - eth0
 - NTP
 - SNMP
 - SMTP
 - GPIO
 - GPS
 - System Tools
- Save/Load Config.
- Logs
- Version Info

Enable(Primary DNS IPv6): If it is needed, click on the checkbox to enable a Primary DNS IPv6.

Primary DNS(IPv6): type here the IP of the desired DNS server.

Enable(Additional #1 DNS IPv6): Check it to enable the first additional DNS IPv6 Server.

Additional #1 DNS(IPv6): type the IP of the DNS server.

Enable(Additional #2 DNS IPv6): Check it to enable the second additional DNS IPv6 Server.

Additional #2 DNS(IPv6): type the IP of the DNS server.

CONFIGURATION

The next two parameters are used to save all previous network settings. The first following button gives a first confirmation of the network parameters, but to make it really effective it is necessary to access the new IP within 5 minutes and it is necessary to press Confirm Network Configuration. This double security is useful in case you have entered wrong addresses or in case there are network problems.

Send Network Configuration: By clicking on this button you send the new network configuration.

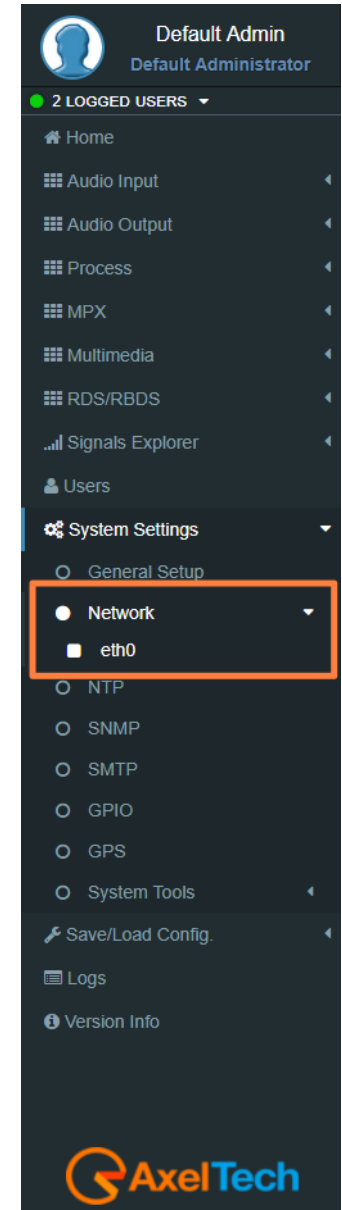
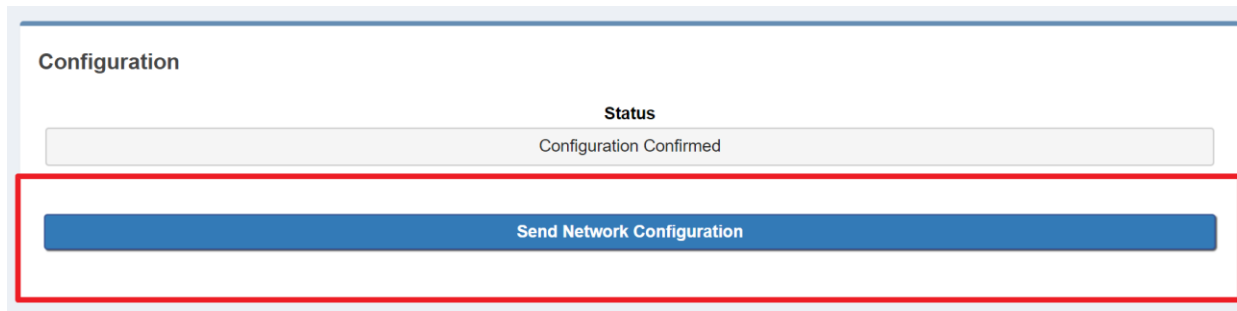

To confirm the process you have to connect to the new set IP and press **Confirm Network Configuration** from: [Setup](#) > [Network](#) > [eth0](#)

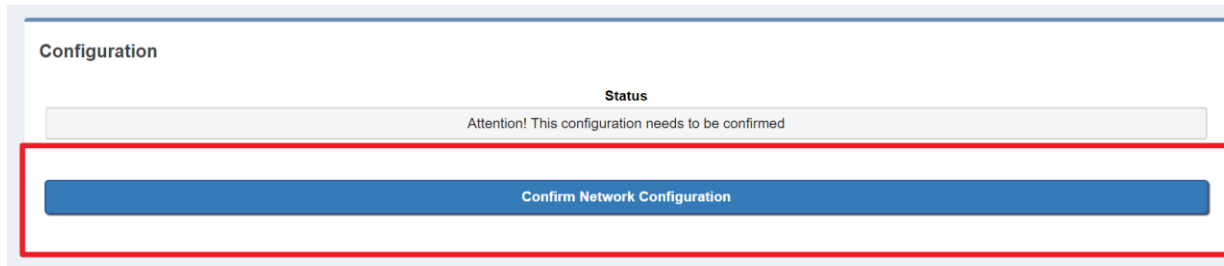

Confirm Network Configuration: If you do not confirm the new configuration within 5 minutes, the last changes are not implemented. Then you have to reconnect by using the **old IP address** and [Send Network configuration](#) again. After the confirmation of the new IP address you will see the following message:

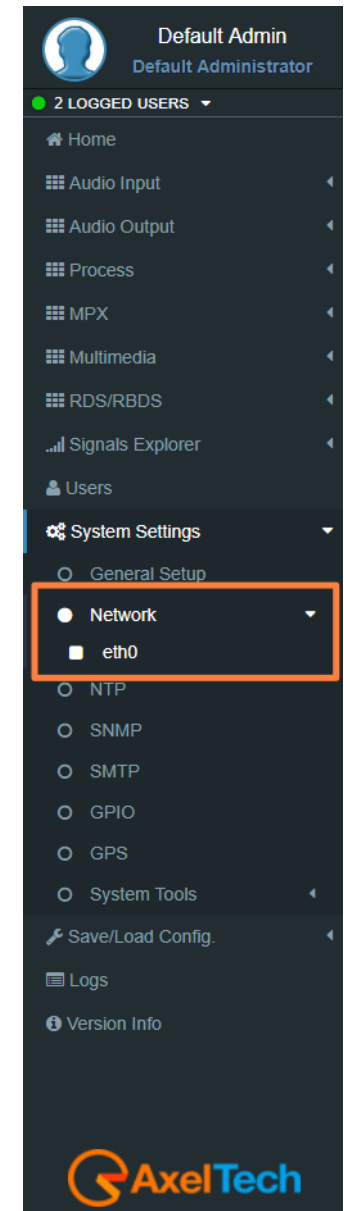
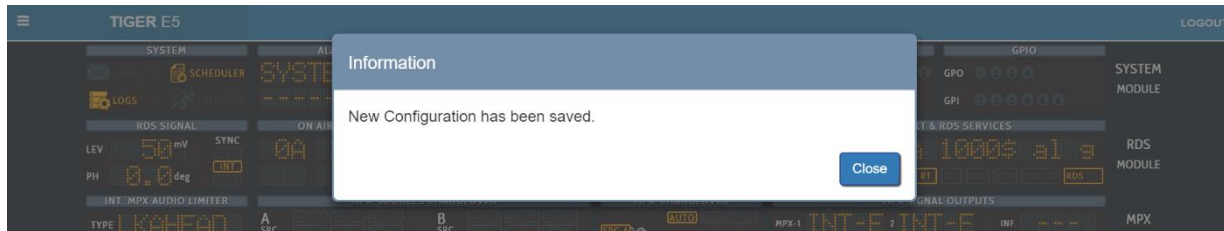

5.5.3 NTP

Network Time Protocol. This section contains all the settings related to NTP features. It is, in fact, possible to connect the device to an NTP server and in this way the device will synchronize its own date and time with the server.

You can set up to three NTP servers. In case there are problems on the first server, the device goes to the second and so on up to the third.

In Setup > NTP you have all the settings related to the Network Time Protocol. Here you can synchronize the device with different desired NTP Servers clock time to start with them the data packet exchange.

GENERAL SETTINGS

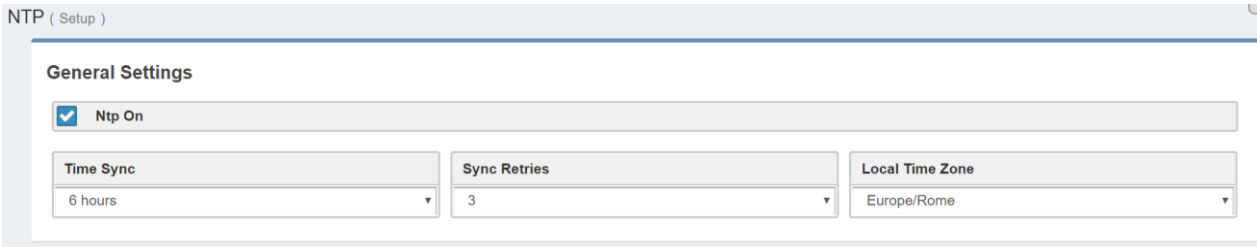

NTP (Setup)

General Settings

Ntp On

Time Sync: 6 hours

Sync Retries: 3

Local Time Zone: Europe/Rome

NTP ON: click on the checkbox to enable/disable the Sync with the desired NTP server

TYME SYNCH: decide the sync interval

SYNC RETRIES: decide the sync retries in case of failure

LOCAL TIME ZONE: select the Local Time Zone related to the geographical device position.

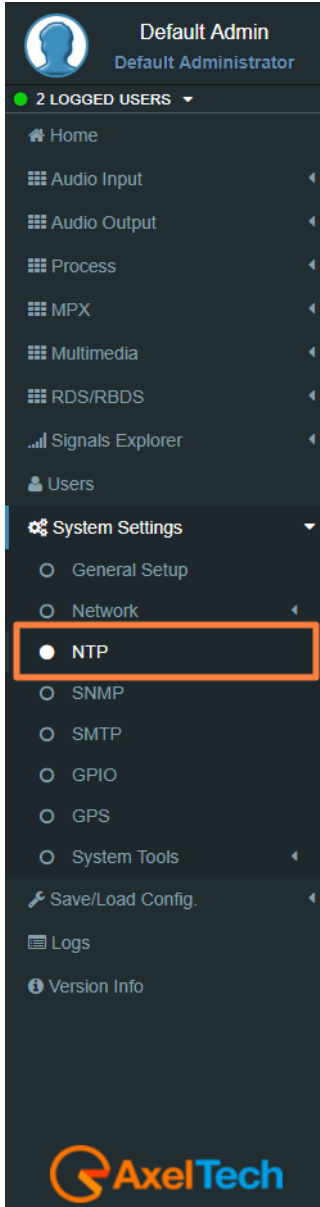

Default Admin
Default Administrator

2 LOGGED USERS

- Home
- Audio Input
- Audio Output
- Process
- MPX
- Multimedia
- RDS/RBDS
- Signals Explorer
- Users
- System Settings
 - General Setup
 - Network
 - NTP**
 - SNMP
 - SMTP
 - GPIO
 - GPS
 - System Tools
- Save/Load Config.
- Logs
- Version Info



PRIMARY NTP SERVER

Primary NTP Server	
IP Address / Url 0.pool.ntp.org	NTP Version Auto
Additional #1 NTP Server	
IP Address / Url 1.pool.ntp.org	NTP Version Auto
Additional #2 NTP Server	
IP Address / Url 2.pool.ntp.org	NTP Version Auto

IP ADDRESS / URL: type the IP/URL of the desired primary NTP server to synchronize the device clock with the server clock.

NTP VERSION(AUTO, V1, V2, V3, V4): select the desired NTP version.

NTP Events

NTP Events	
<input checked="" type="checkbox"/> masked	NTP Warning
<input checked="" type="checkbox"/> masked	NTP Alarm

Masked/Unmasked NTP Warning: the warning control records in the logs section a connection problem with one or more DNS Servers. Select Mask to enable the record or Unmask to disable it

Masked/Unmasked NTP Alarm: the Alarm control records in logs section a connection problem with all DNS Servers. Select Mask to enable the record or Unmask to disable for it.

The event section is useful to mask/unmask problems detection with the connection between the device and the NTP Servers.

Default Admin
Default Administrator

2 LOGGED USERS

- Home
- Audio Input
- Audio Output
- Process
- MPX
- Multimedia
- RDS/RBDS
- Signals Explorer
- Users
- System Settings**
 - General Setup
 - Network
 - NTP**
 - SNMP
 - SMTP
 - GPIO
 - GPS
 - System Tools
 - Save/Load Config.
 - Logs
 - Version Info

5.5.4 SNMP

The **Simple Network Management Protocol** (SNMP) is used mostly in large networks to monitor network-attached devices for conditions that warrant administrative attention. The RDS encoder supports SNMP.

You can setup all parameters related to the **Simple Network Management Protocol**. Here you can define parameters for different **NMS** (Network Management Server) for the network and trap management.

SNMP Settings

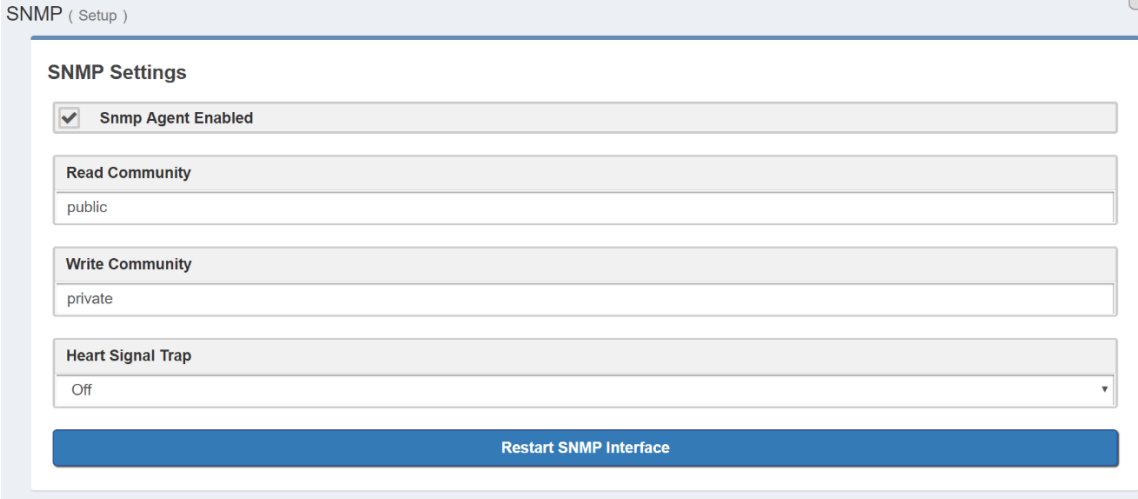

SNMP (Setup)

SNMP Settings

Snmp Agent Enabled

Read Community
public

Write Community
private

Heart Signal Trap
Off

Restart SNMP Interface

SNMP Agent Enabled: click on this check box to enable or disable the SNMP agent for the warning or alarm traps.

Read Community: it is set on “public” by default. It is the Community String related to the SNMP requests from NMS to the device. If you want to protect your data change it here and in the NMS.

Public/Private: it is set on “private” by default. It is the Community String related to the SNMP device settings from NMS to the device. To have better protection in the Write Community change the Community String here and in the NMS.

Heart Signal Trap: select between ON/OFF if you want to enable/disable the device Heartbeat signal trap.

Restart SNMP Interface: This command restarts the SNMP interface.

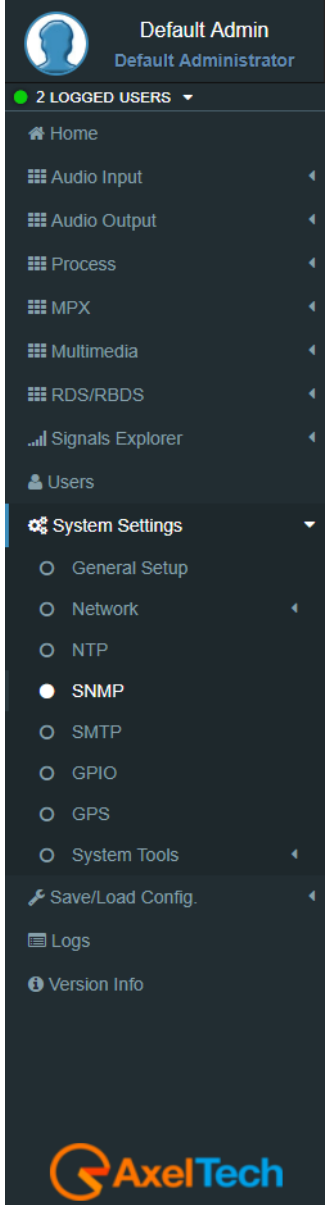

Default Admin
Default Administrator

2 LOGGED USERS

- Home
- Audio Input
- Audio Output
- Process
- MPX
- Multimedia
- RDS/RBDS
- Signals Explorer
- Users
- System Settings**
 - General Setup
 - Network
 - NTP
 - SNMP**
 - SMTP
 - GPIO
 - GPS
 - System Tools
- Save/Load Config.
- Logs
- Version Info



5.5.5 SMTP

Here can setup all parameters related to the **Simple Mail Transfer Protocol**. you can define parameters for different SMTP servers for the e-mail notification on the device functioning.

SMTP Settings

SMTP Settings

SMTP On

Delivery Interval
6 hours

Sender E-Mail Name FALCONX7	Sender Display Address noreply@mail.com	Sender E-Mail Subject [FALCONX7] Periodic Report Message
--------------------------------	--	---

SMTP Receivers

Receiver #1 -	Receiver #2 -
Receiver #3 -	Receiver #4 -

SMTP On: Click on the checkbox to activate/deactivate the SMTP service

Delivery Interval: Select the desired Delay Interval for the Email Notifications. If **SMTP On** is checked you will have Email Notifications every Delivery Interval.

Sender E-Mail Name: Type here a standard Sender E-mail Name

Sender Display Address: Type here the default Sender Display Address. Receivers will read this sender address.

Sender E-Mail Subject: Email Receivers will read this E-Mail Subject.

Default Admin

Default Administrator

2 LOGGED USERS

- Home
- Audio Input
- Audio Output
- Process
- MPX
- Multimedia
- RDS/RBDS
- Signals Explorer
- Users
- System Settings
 - General Setup
 - Network
 - NTP
 - SNMP
 - SMTP
 - GPIO
 - GPS
 - System Tools
- Save/Load Config.
- Logs
- Version Info

MAIN SMTP Server Settings

Main SMTP Server Settings

Description

Server IP Address / Url Port
25

Security Authorization Method
None None

Username Password

Description: type here a short description of the desired main SMTP Server

Server IP Address / Url: the IP Address / Url of your SMTP server domain

Port: TCP port for the communication

Security protocol: Network Security protocol

Authorization Method: choose the desired method from the list

Username: email username

Password: email password

Default Admin
Default Administrator

2 LOGGED USERS ▾

- Home
- Audio Input
- Audio Output
- Process
- MPX
- Multimedia
- RDS/RBDS
- Signals Explorer
- Users
- System Settings ▾
 - General Setup
 - Network
 - NTP
 - SNMP
 - SMTP
 - GPIO
 - GPS
 - System Tools
- Save/Load Config.
- Logs
- Version Info

5.5.6 GPIO

In [Setup > GPIO](#) you can setup all parameters related to the General Purpose **Input/Output**. Here you can define the behaviour of different **GPI** or **GPO** devices.

GPI Logic

GPI (Setup)

GPI Logic

GPI 1
Positive Logic

GPI 2
Positive Logic

GPI 3
Positive Logic

GPI 4
Positive Logic

GPI 5
Positive Logic

GPI 6
Positive Logic

Positive Logic: the event is logged when the GPI circuit is closed.

Negative Logic: the event is logged when the GPI circuit is opened.

GPI Events: select masked but the GPI in action. Unmasked to not in action it.

GPI Events

unmasked

masked

masked

Default Admin
Default Administrator

2 LOGGED USERS

- Home
- Audio Input
- Audio Output
- Process
- MPX
- Multimedia
- RDS/RBDS
- Signals Explorer
- Users
- System Settings**
 - General Setup
 - Network
 - NTP
 - SNMP
 - SMTP
 - GPIO**
 - GPS
 - System Tools
- Save/Load Config.
- Logs
- Version Info

GPO LOGIC

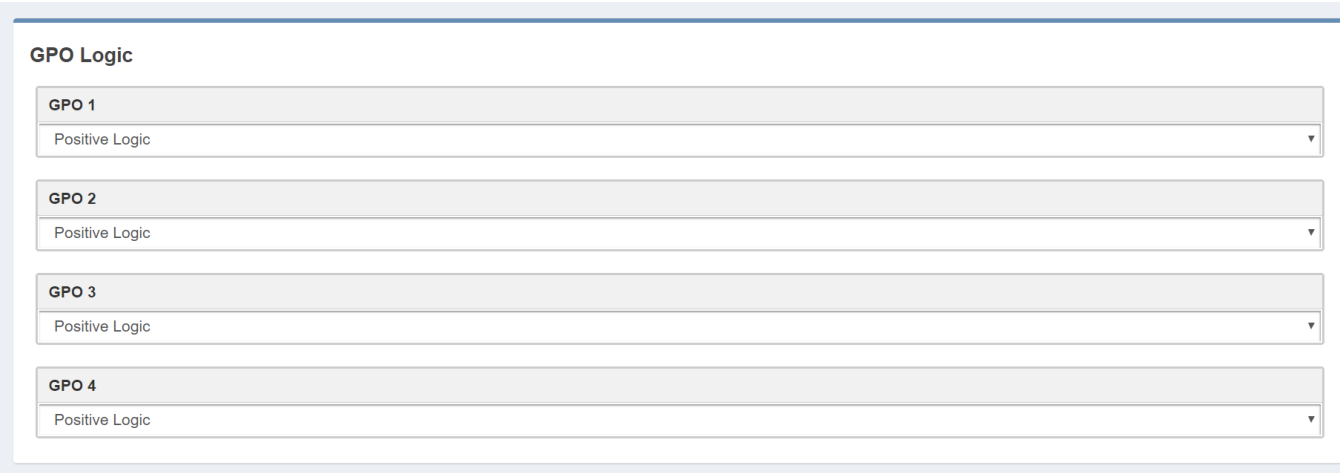

Positive Logic: the generated event is the closing of the GPO circuit.

Negative Logic: negative logic: the generated event is the opening of the GPO circuit.

In **GPO Event Notifications** you can decide to root to the GPO device: no Event Source(OFF), to root all Event Sources(ON), to root a selected Event Source (for example, NTP Alarm).

in every GPO menu select the event source that you want to listen, as shown in the following picture:

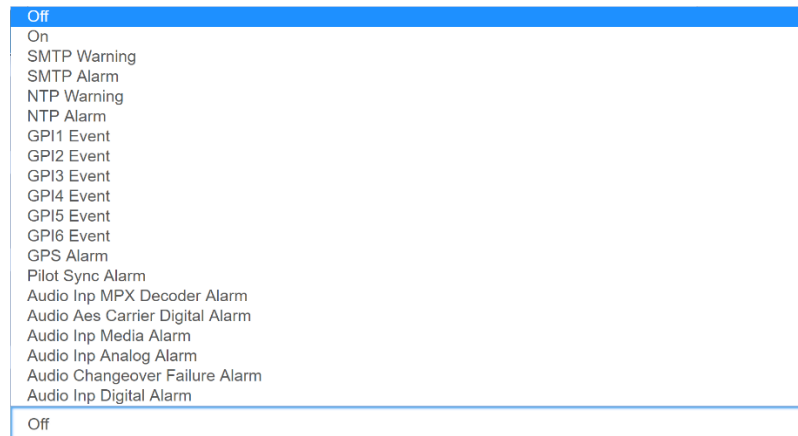

Pilot Sync Alarm: alarm starting when the frequency of the encoded RDS/RBDS signal is out of sync with an available external pilot(analogue MPX frequency / digital frequency by the SYNC/MPX inputs).

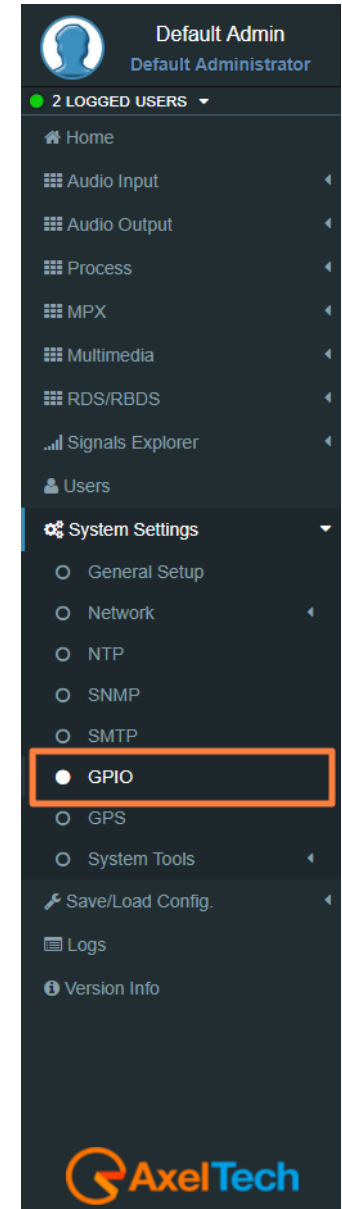

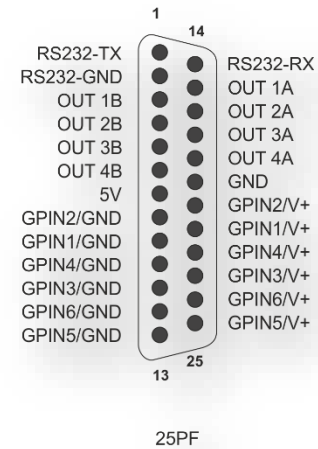
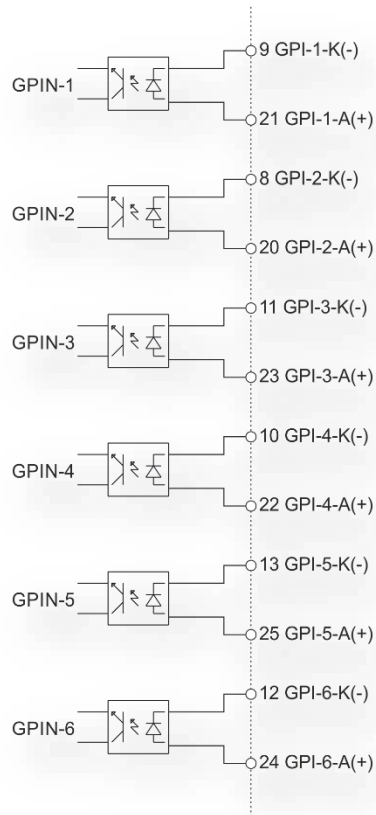
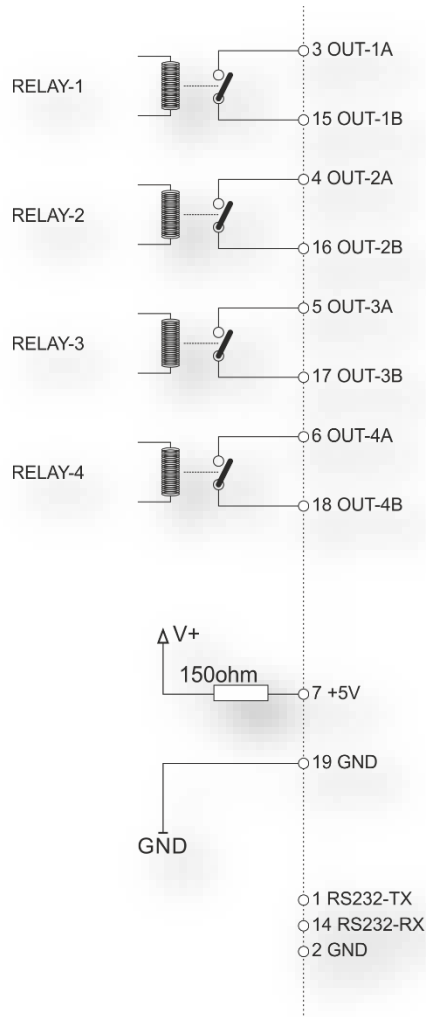

Default Admin
Default Administrator

2 LOGGED USERS

- Home
- Audio Input
- Audio Output
- Process
- MPX
- Multimedia
- RDS/RBDS
- Signals Explorer
- Users
- System Settings**
 - General Setup
 - Network
 - NTP
 - SNMP
 - SMTP
 - GPIO**
 - GPS
 - System Tools
 - Save/Load Config.
 - Logs
 - Version Info

AxelTech

5.5.7 GPS

In [Setup > GPS](#) you can setup all parameters related to the **Global Positioning System**. Here you can define parameters for the desired **GPS** device for the satellite geolocation.

General Settings

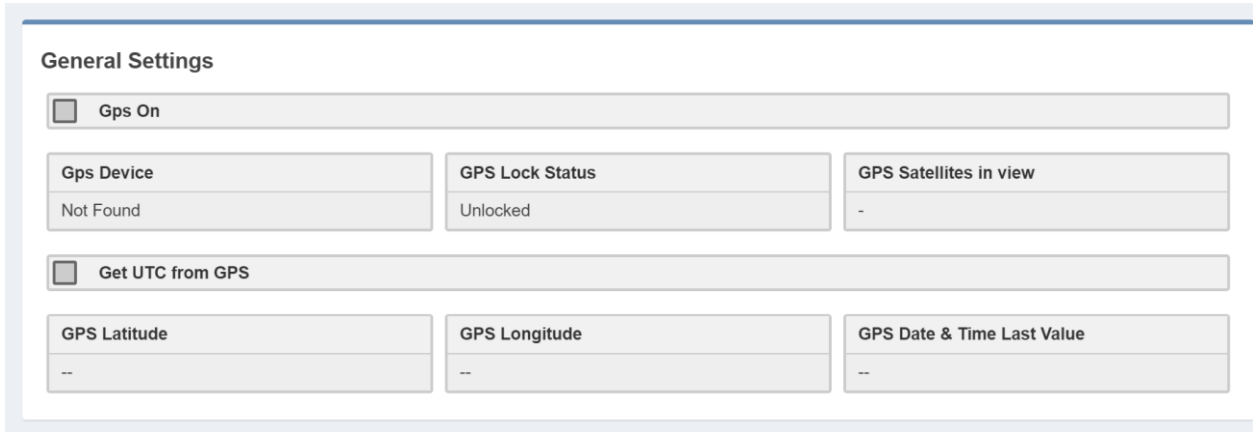

The screenshot shows the 'General Settings' page for GPS configuration. It includes a 'Gps On' checkbox, a 'Gps Device' field (Not Found), 'GPS Lock Status' (Unlocked), 'GPS Satellites in view' (-), a 'Get UTC from GPS' checkbox, 'GPS Latitude' (--), 'GPS Longitude' (--), and 'GPS Date & Time Last Value' (--).

Gps On: Enable/Disable the GPS device

Gps Device: Name of the GPS device connected

GPS Lock Status: Lock/Unlock the GPS status

GPS Satellites in view: Satellites Number in view

GPS Latitude: Type here the Latitude coordinate. If GPS is turned on this value is automatically inserted

GPS Longitude: Type here the Longitude coordinate. If GPS is turned on this value is automatically inserted

GPS Date & Time Last Value: Type here the Date and Time. If **Get UTC from GPS** is enabled this value is automatically inserted

GPS Events

Masked/Unmasked GPS Alarm: the alarm control logs a connection problem with the GPS device. Select Masked to enable the log or Unmasked to disable it

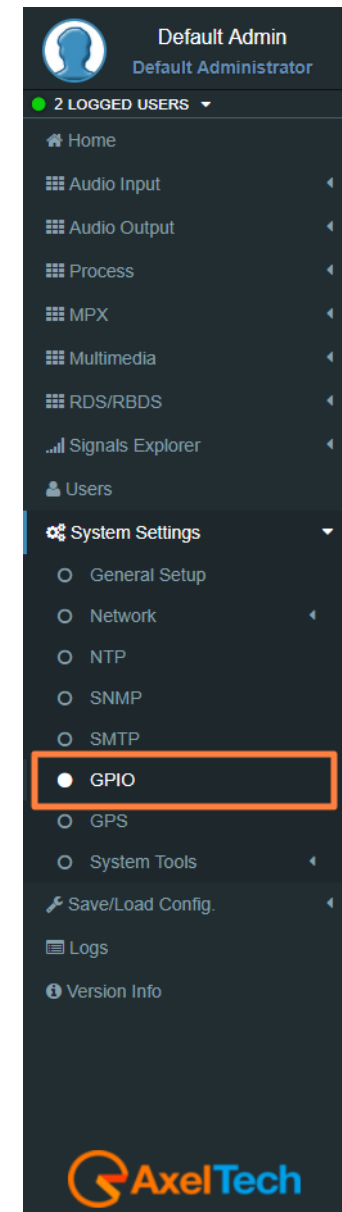

The screenshot shows the system settings menu. The 'GPIO' option is selected and highlighted with a red box. The menu includes options like Home, Audio Input, Audio Output, Process, MPX, Multimedia, RDS/RBDS, Signals Explorer, Users, System Settings (General Setup, Network, NTP, SNMP, SMTP, GPIO, GPS, System Tools), Save/Load Config., Logs, and Version Info.

5.5.8 SYSTEM TOOLS

5.5.8.1 UPDATES

LOAD A NEW FIRMWARE FILE

To load a new firmware file inside the device you have to connect with it through an FTP Client (in this example we use Filezilla). The device must be reachable.

In the following line you can find for the FTP Credentials useful for the connections:

Host: **device IP** XXX.XXX.XXX.XXX User: **upgrader** Password: **ax-upgrader**

The FTP client will connect directly to the right upgrader folder (it will not be possible to navigate in different folders).

Paste the new firmware file in the red area as shown in the picture by drag and drop.

N.B: The update file must be provided by **AXEL TECHNOLOGY**.

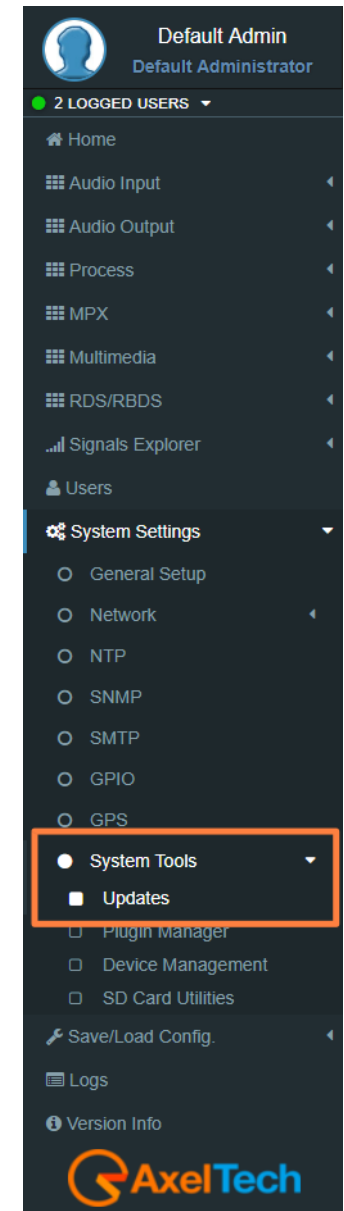
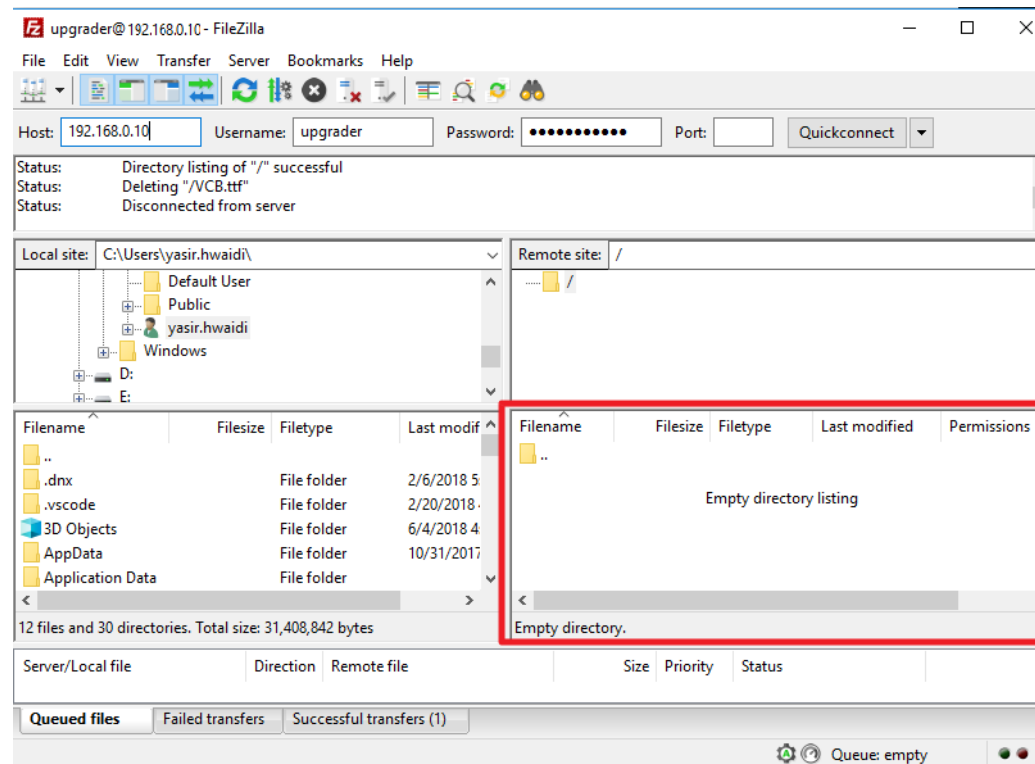

FIRMWARE UPDATES

After uploading the update file into the device by the FTP Client. Now we have to go to the web interface to login in and following this steps [SETUP > SYSTEM TOOLS > UPDATES](#). By pushing the **Check for Firmware Updates** you will search if there is an FW update file available. If so, you can update the Firmware clicking on '**Update**' in the window that will appear. During this process, you should not shut down or reboot this device. When it is ready it will REBOOT the device automatically. Finally, it will be ready to use.

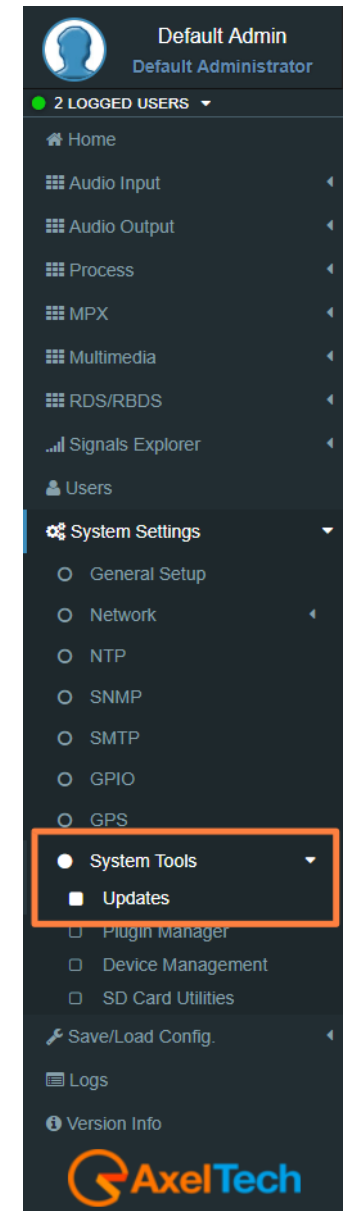
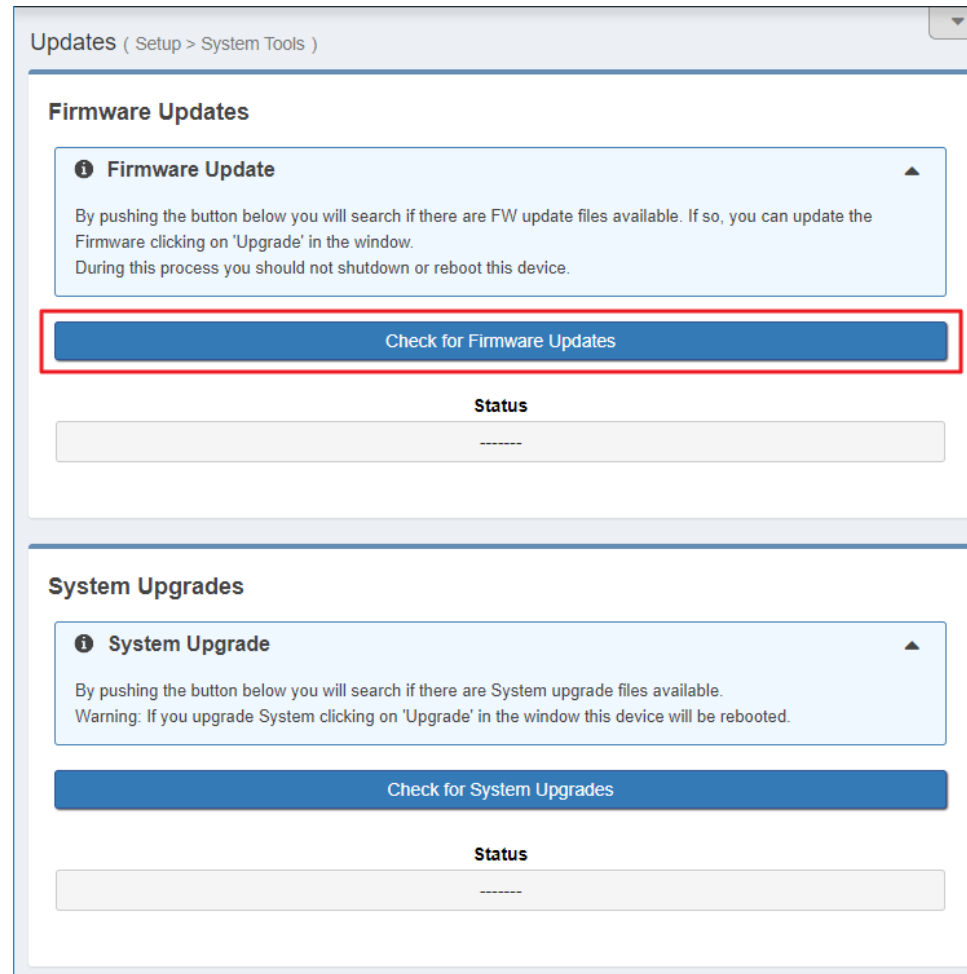

LOAD A NEW SYSTEM UPGRADE FILE

To load a new system upgrade file inside the device you have to connect with it through an **FTP Client** (in this example we use Filezilla). The device must be reachable.

In the following line you can read for the FTP Credentials useful for the connections:

Host: **device IP XXX.XXX.XXX.XXX** User: **sysupgrader** Password: **ax-sysupgrader**

The FTP client will connect directly to the right upgrader folder (it will not be possible to navigate in different folders).

Paste the new firmware file “**SysUpgrade-XXX.tgz**” in the red area as shown in the picture by drag and drop.

N.B: The update file must be provided by **AXEL TECHNOLOGY**.

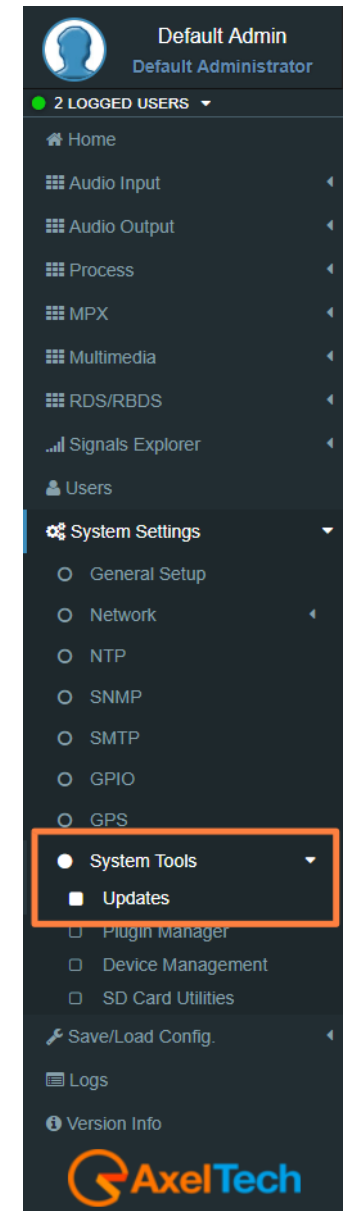
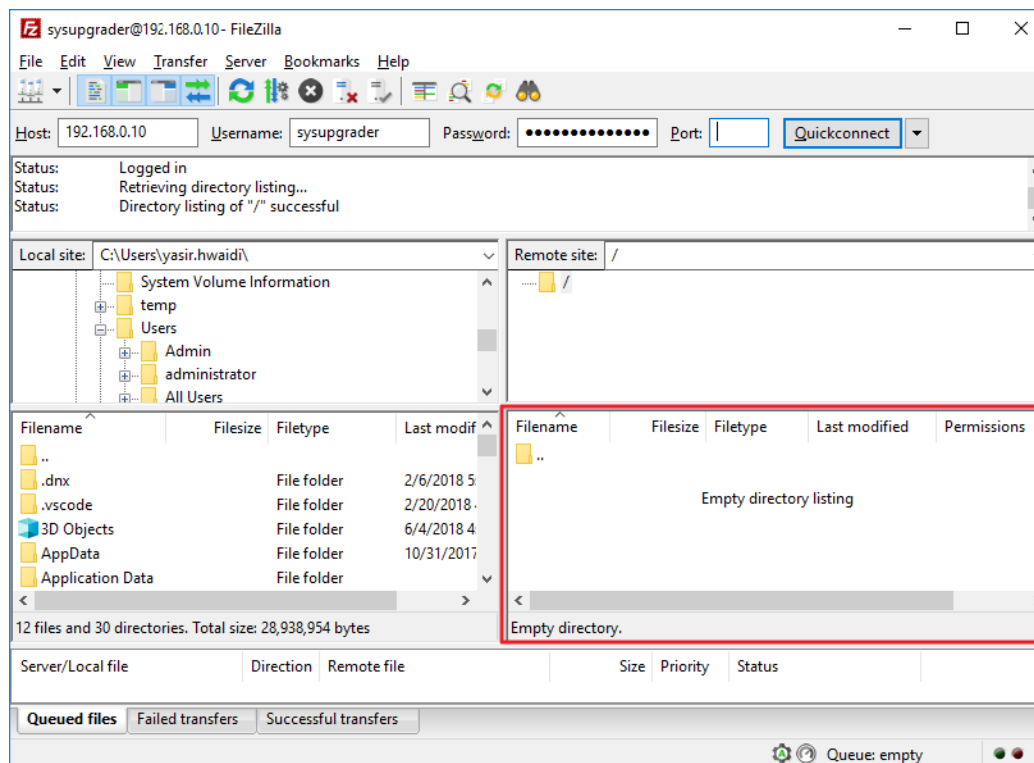

After uploading the system update file into the device by the FTP Client. Now we have to go to the device web interface to login in and following this steps [SETUP > SYSTEM TOOLS > UPDATES](#). By pushing the **Check for system Upgrades** you will search if there is an FW update file available. If so, you can update the system by clicking on **'Upgrade'** in the window that will appear. During this process, you should not shut down or reboot this device. When it is ready it will REBOOT the device automatically. Finally, it will be ready to use.

The screenshot shows the 'Updates' page in the web interface, located under 'Setup > System Tools'. It contains two main sections:

- Firmware Updates:** Includes an information icon, a title 'Firmware Update', and a text box explaining that pushing the button below will search for FW update files. Below this is a blue button labeled 'Check for Firmware Updates' and a 'Status' field with a dashed line.
- System Upgrades:** Includes an information icon, a title 'System Upgrade', and a text box explaining that pushing the button below will search for system upgrade files, with a warning that the device will be rebooted. Below this is a blue button labeled 'Check for System Upgrades' (highlighted with a red box) and a 'Status' field with a dashed line.

The screenshot shows the sidebar menu of the web interface. At the top, it says 'Default Admin' and 'Default Administrator'. Below that, it shows '2 LOGGED USERS'. The menu items include: Home, Audio Input, Audio Output, Process, MPX, Multimedia, RDS/RBDS, Signals Explorer, Users, System Settings (with a sub-menu), System Tools (highlighted with an orange box), Updates (highlighted with an orange box), Plugin Manager, Device Management, SD Card Utilities, Save/Load Config., Logs, and Version Info. The AxelTech logo is at the bottom.

5.5.8.2 PLUGIN MANAGER

LOAD A NEW Plugin CODE

go to the web interface to login in and following this steps [SETUP > SYSTEM TOOLS > Plugin Manager](#). Copy your Plugin Code and paste it in the **(Insert Plugin Key here)** as shown in the next figure in the red rectangle. Now you have to click on the **Activate Plugin**. During this process, you should not shut down or reboot this device. When it is ready it will REBOOT the device automatically. Finally, it will be ready to use.

N.B: The Plugin Code must be provided by **AXEL TECHNOLOGY**.

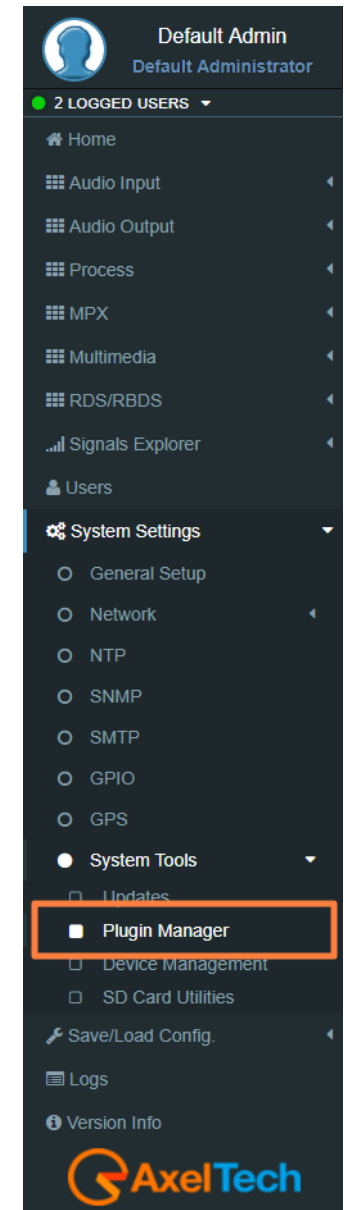
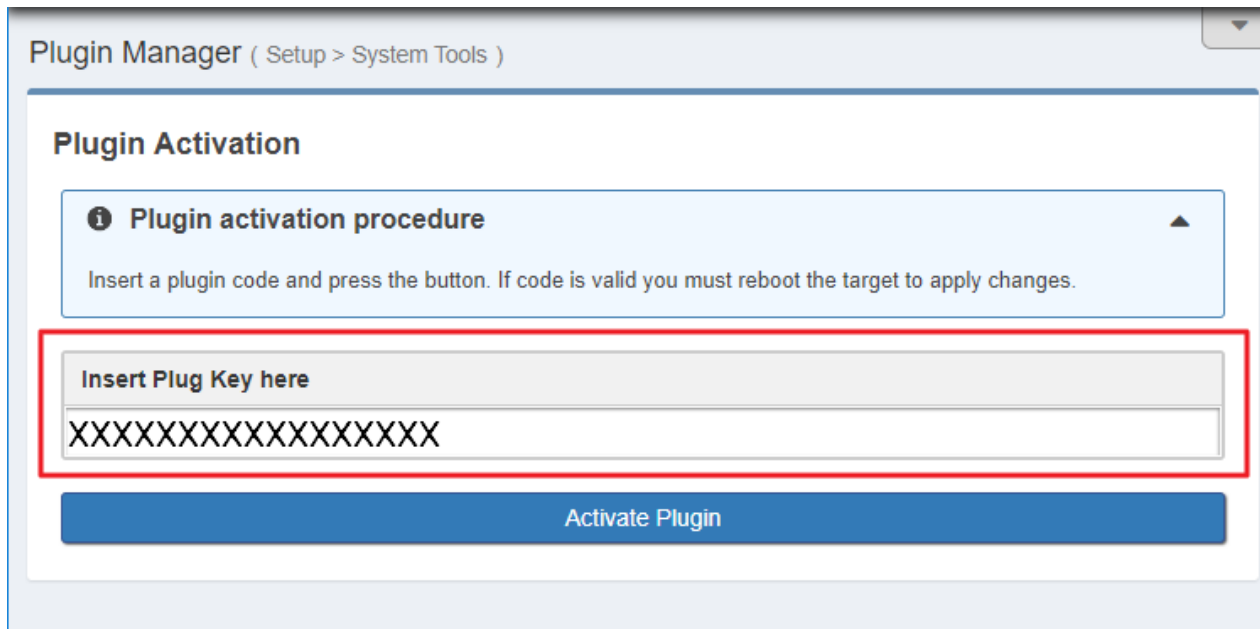

5.5.8.3 DEVICE MANAGEMENT

A. Reboot Device

This button will cause a device reboot.

B. Shutdown Device

This button will cause a device shutdown.

C. Reset to Defaults

This button will cause a device reset.

Warning:

This operation will erase ALL target data included saved presets and users.

After confirmation device will restart.

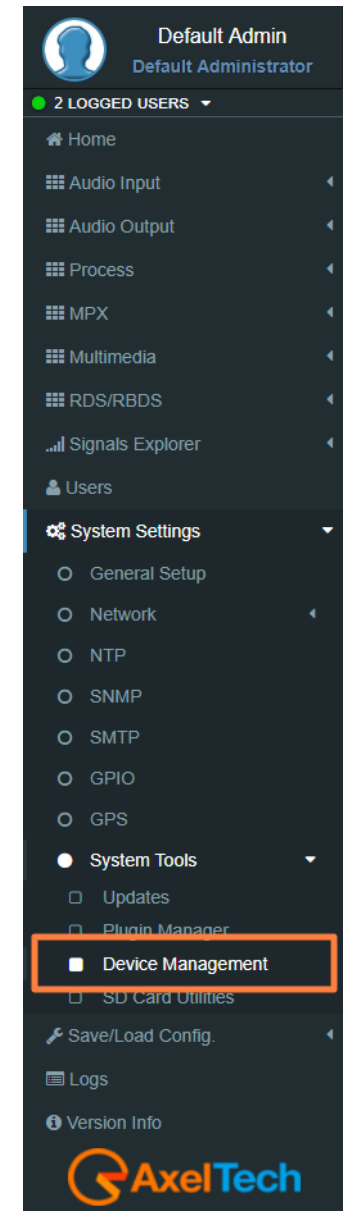
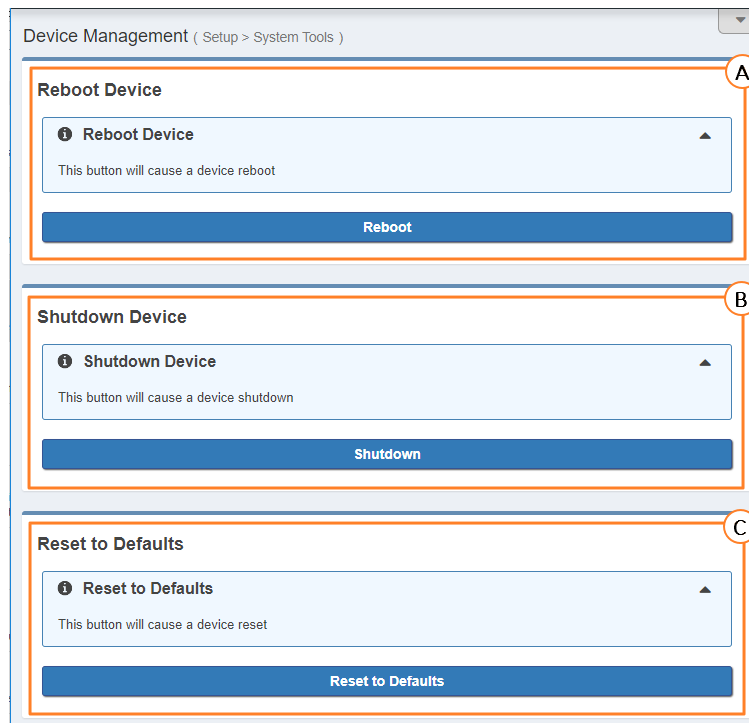

5.5.8.4 SD CARD UTILITIES

SD STATUS

SD Found	SD Structure
No	Missing SD

SD Found: If an external SD is found, this status will be OK, otherwise to use the tools below you need to insert (or change) an SD card in the external back slot.

SD Structure: The external SD card must be formatted and prepared with a particular folder tree. If this status is not OK, you need to format & prepare it using the format button.

FORMAT AND PREPARE

This procedure will format the external SD card and prepares it to receive data.

CLONING TOOLS

Clone to SD	
Status	

Cloning Device	
Clone from SD	
Status	

Clone to SD: This procedure will create a clone data structure on the external SD card.

Clone from SD: This procedure will create a clone data structure from the external SD card.

Important: System will be offline for a few minutes.LOGS

Very Important: Do not power-off target or remove SD card immediately after cloning process has finished!

Do not remove SD card if power is ON.

Wait at least a couple of minutes before shutdown the device.

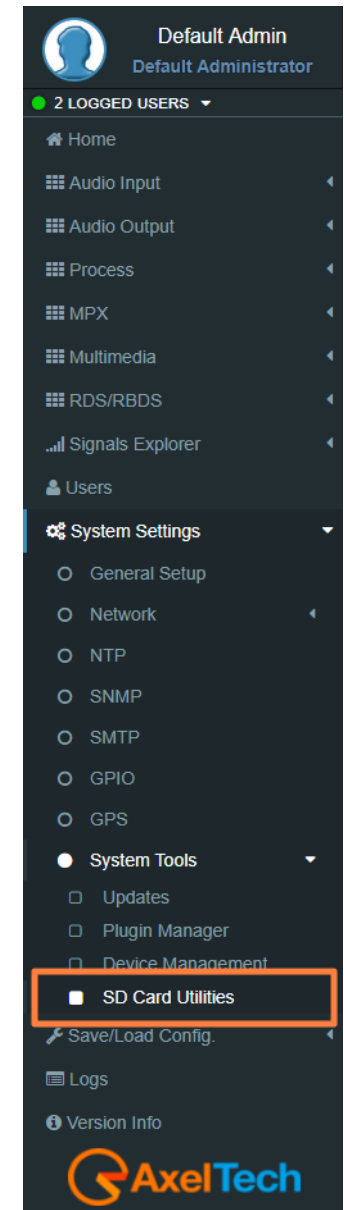

5.1 SAVE/LOAD CONFIG.

5.1.1 TO/FROM FILE

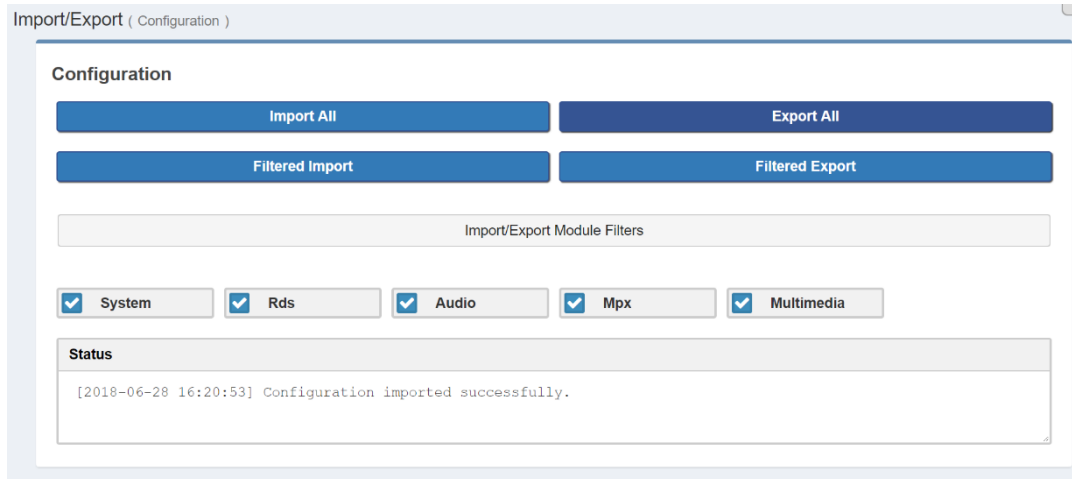

Import: Import an existing .cnf file (json format) with all configs.

Export: Export a .cnf file (JSON format) with all configs in the desired folders.

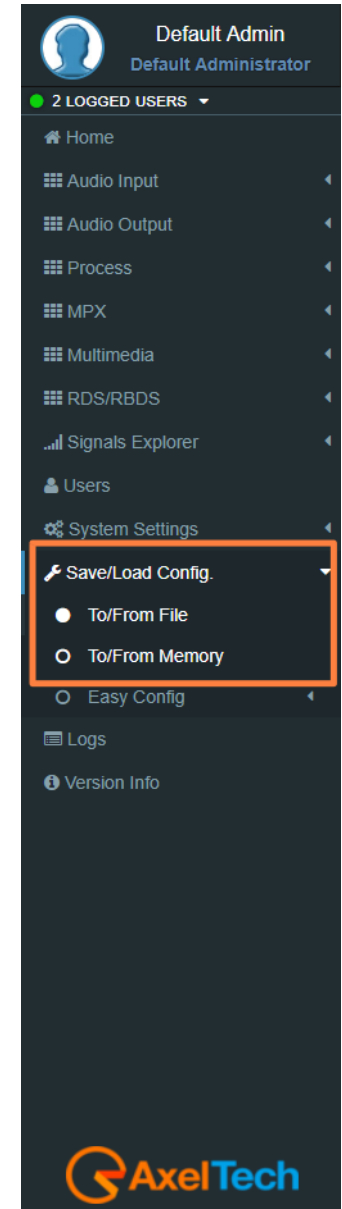
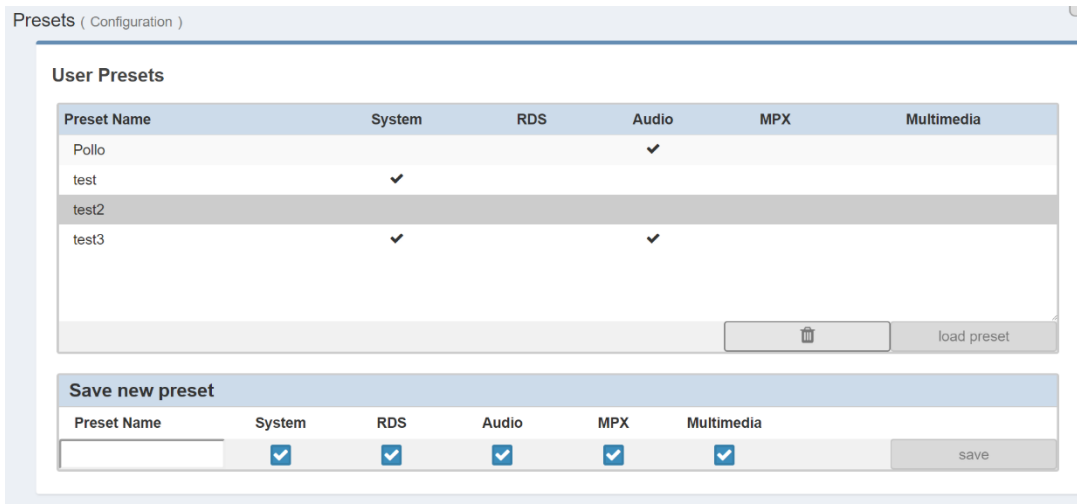

5.1.2 EASY CONFIG

5.1.2.1 Quick RDS Setup

Here you can access to basic rds settings and make your radio come to life in a few simple steps!

To begin setup procedure, press the button below.

This operation resets and prepare **Dataset 1** to broadcast services shown below.

Quick Setup Menu:

From this quick setup, you can set the basic RDS parameters to make your radio come to life in a few simple steps.

To begin the quick setup procedure. The pressure of this button resets and prepare “**Dataset 1**” to broadcast services shown below.

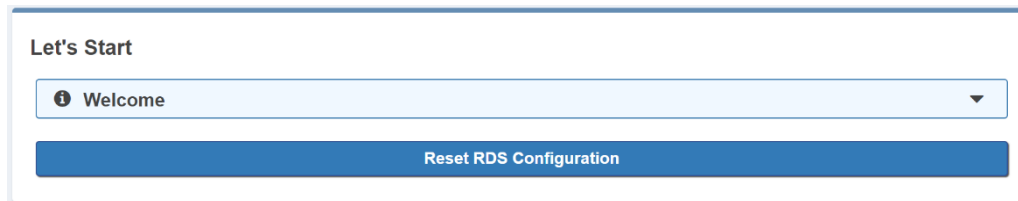

To start the RDS configuration click on **Confirm**

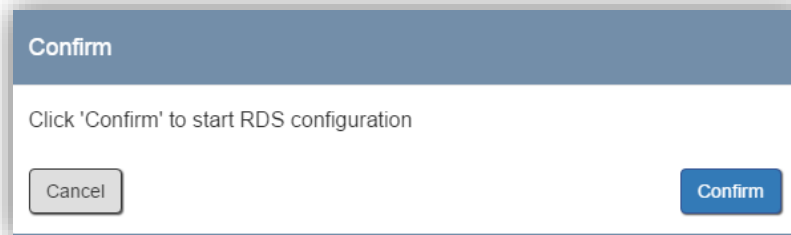

Go down on the same page, read the instructions until the end of the page and fill all the parameters. You can set all the most important **RDS** Parameters. **In this way, you can be immediately ONAIR with your RDS.** We suggest you change device Network Ip Address and to create the Users that you need.

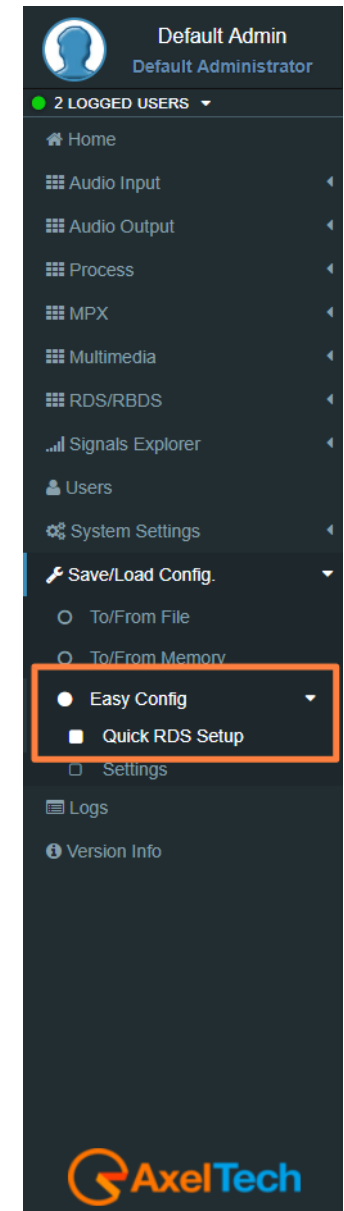

Data set

Data set it's the whole RDS setup that you can create. You can find available from **DATASET1** up to **DATASET8**. This gives you more ability to change all parameters needed in one click. [RDS/RBDS>Basic Settings>Active Dataset Selection](#).

Rds Signal Settings

In this section you can choose **Rds Level**.

Shown value is suitable for most cases, but feel free to change it to get the best result.

For Rds Level acceptable values are from **0** up to **8100 mVpp**.

Rds Signal Settings

Adjust the Rds Signal

Rds Level (mVpp)

50

Program Services

PI: This is the most important datum. This **4 hexadecimal code** is the unique identifier for your radio.

PI

5001

PS: Type here your Radio's name. Remember: you have at least 8 chars.

PS

NETWRK01

TP: If your radio carries out traffic infos set this to On.

TP

Off

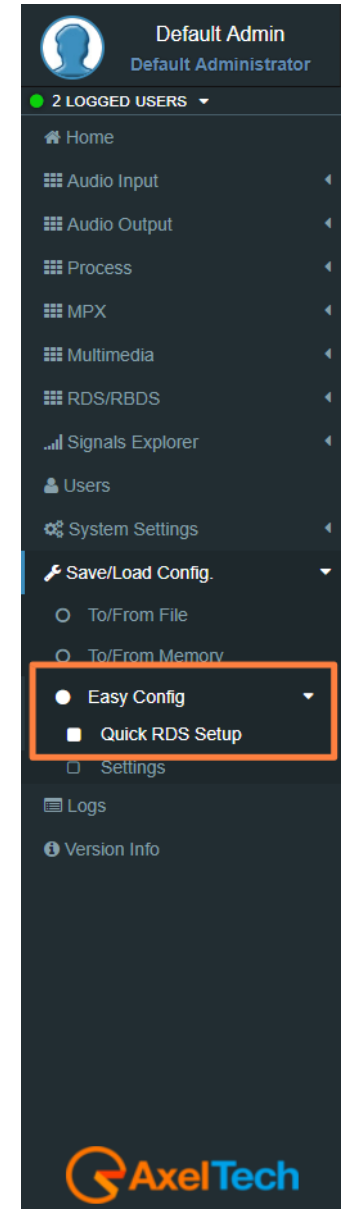

PTY: Tells your listeners which type of (most of) programs you're transmitting. Are you a Classical Music radio? Do you prefer Rock? Here you can choose the best suit for you.

PTY

No Program Type

No Program Type

News

Current Affairs

Information

Sport

Education

Drama

Culture

Science

Varied

Pop Music

Rock Music

Easy Listening Music

Light Classical

Serious Classical

Other Music

Weather

Finance

Children's Programs

Social Affairs

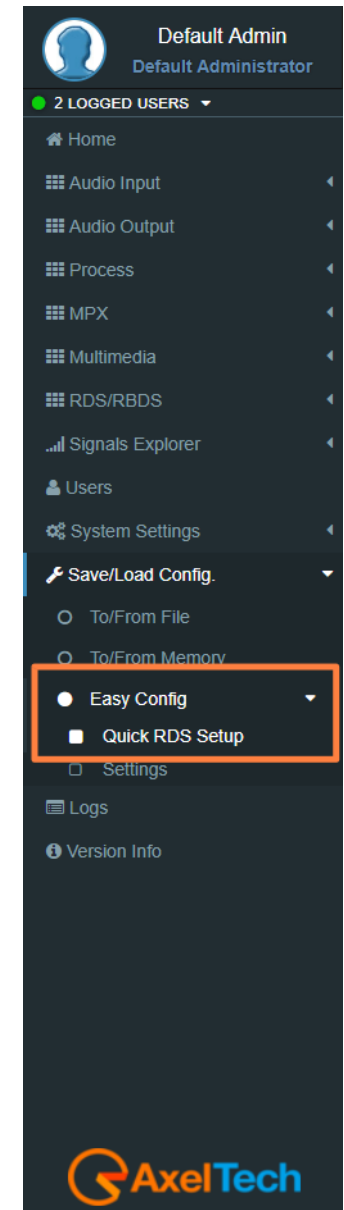

Music/Speech: You can tell the receiver whether the current audio program is music (or speech) oriented.

Music/Speech

Speech

Speech

Music

Decoder Information: This allows you to indicate to the receiver if the decoder is stereo or mono. In every most of cases can be leaved on Stereo.

Decoder Information
Stereo
Mono
Stereo
Mono-AH
Stereo-AH
Mono-Compr
Stereo-Compr
Mono-AH-Compr
Stereo-AH-Compr
Mono-Dyn
Stereo-Dyn
Mono-AH-Dyn
Stereo-AH--Dyn
Mono-Compr-Dyn
Stereo-Compr-Dyn
Mono-AH-Compr-Dyn
Stereo-AH-Compr-Dyn

NOTE:These **PS** and **PTY** settings are the basic ones but this machine has extended powerful features. Please refer to documentation to discover the full features!

Alternative Frequencies

Alternative frequencies give the ability to automatically link the receiver to two or more transmitters carrying the same program material. The receiver will automatically switch from one transmitter to another when the signal quality becomes unacceptable. If you have a limited **AF** number (less than 25 frequencies) and you don't have particular needs you can choose **Method A**. You should use **Method B** whenever your transmitter and associated repeater stations exceeds **25 frequencies**, or if you need to indicate frequencies which belong to different region which at times carry different programmes.

Let's make a couple of examples.

- First we want to set up a **method A** list where your station's Main frequency is on **100.0 MHz** and the alternative frequencies are **98.4, 101.7** an **104.1 MHz**.

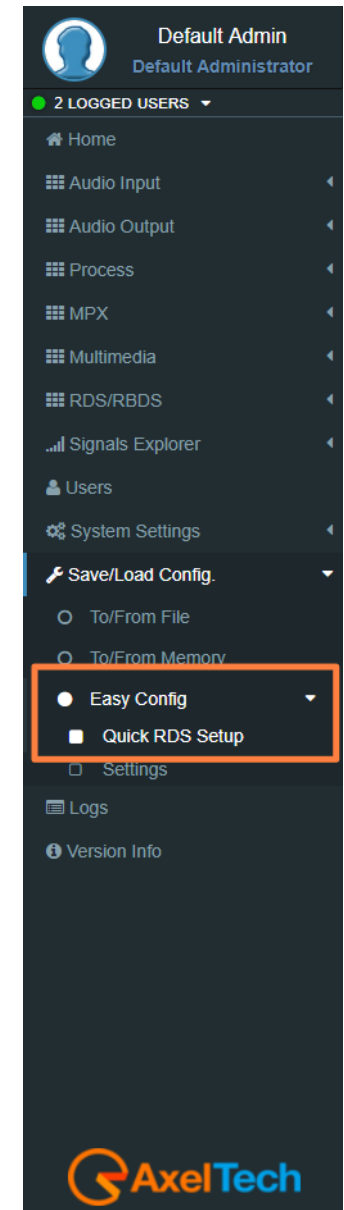

- Press the button marked with a plus (+).
- This allows to edit a new **AF** list.
- From the combo box tagged 'Method' choose 'A'.
- In the '**Tuned. Freq.**' edit type your main frequency always completed with decimal (**100.0**).
- In the AF list write down the alternative frequencies separated by a comma (**98.4, 101.7, 104.1**).

Method	Tuned	AF List
A	100.0	101.0, 102.0, 103.0, 104.0, 105.0

- Finally, press '**add**' button.

Now your list is inserted. You can see it in the frame above.

If you want to add a new list press again the (+) button and repeat each step.

If an alert appears check what you have typed (there can be a mistake). In doubt, refer to the manual.

Alternative Frequencies		
AF Lists		
Lists	Tuned	
(5-B)	90.0	90.1 90.2 90.3 90.4
(5-B)	91.2	92.4 92.5 100.3 100.6
(2-B)	88.5	88.6

Now we want to handle a more sophisticated network that shares the same audio program but differs in commercial advising from zone to zone.

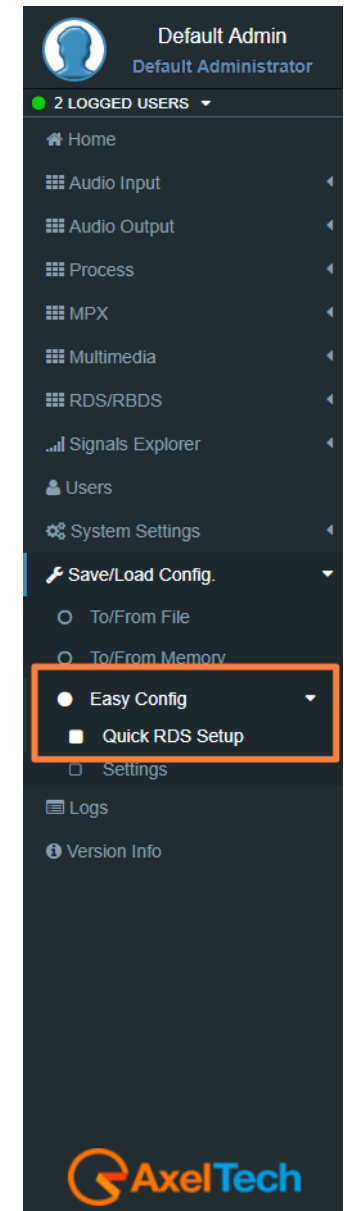

RadioText

Radiotext is a very useful **Rds** feature that allows your listeners to get more informations about what are they hear or about your Radio.

This feature, now supported by all modern receivers, consists of messages up to **64 characters** long.

You can choose what and how many time show an information.

Let's make an example.

- First of all, press the button marked with a plus (+).
- This allows to edit a new **radiotext**.
- From the combo box tagged '**Reps**' choose '**4 reps**'.
- From the '**A/B Flag**' combo choose '**On**'.
- In the edit box '**Radiotext**'

type: *'You are listen to MARIAH CAREY with SOMEDAY'*.

- Finally press the '**add**' button. And it's done!

Now you can see above your broadcasted radiotext.

Go ahead. We want to alternate this info with a Network information.

- Let's press '+' button again.
- Choose: **Reps = 1 rep, A/B Flag = On**.
- **Type on edit:** *'Live ABC Radio at: +012-345-6789 live@abcradio.org @abcRadio'*
- Press 'add' to update the Radiotext buffer.
- Now you can see on customer's receiver two alternating text: a song (that persists more) and contact infos (that displays for a lesser time).
- You can add up to **32 phrases** in this buffer. The system cycles each phrase (from the first to the last) for '**Reps**' times befor process next one.

Once last one was processed, the system restart from the first.

The **A/B flag** when set to '**On**' makes the customer's display is wiped each time a new phrase is shown.

NOTE:This RT setting is the basic one but this machine has extended powerful features. Please refer to documentation to discover the full features!

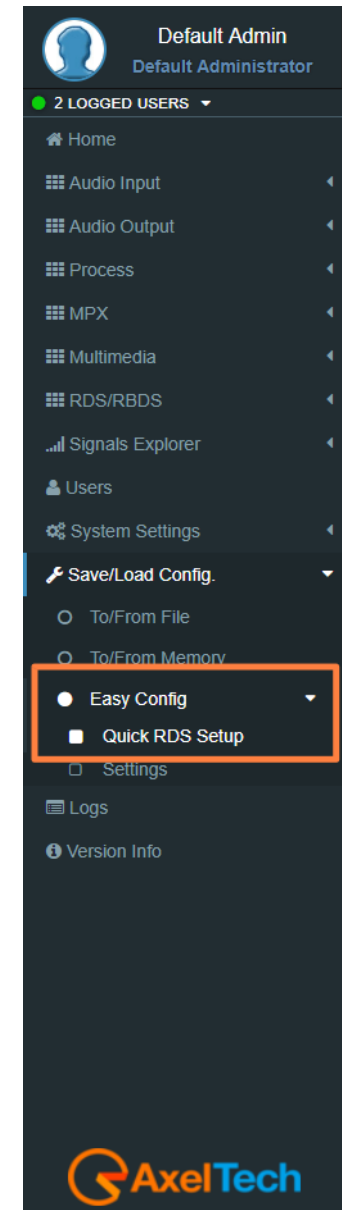

Extended Radiotext using SMB

Configuration

For using properly **SMB/Samba** features, it's required to complete the following form with the configuration of the remote server.

<input checked="" type="checkbox"/> Active	
Hostname IP / Url 10.0.127.84	Smb/Samba Share DJPROM
User Name Admin	Password TMSLogin

Extended RDS and RT Sources

Samba requires the activation of RDS Extended functions.

Rds Global Extended Mode

Rds Global Extended Mode
Enabled
Disabled
Enabled
Enabled by GPI 1
Enabled by GPI 2
Enabled by GPI 3
Enabled by GPI 4
Enabled by GPI 5
Enabled by GPI 6
Disabled by GPI 1
Disabled by GPI 2
Disabled by GPI 3
Disabled by GPI 4
Disabled by GPI 5
Disabled by GPI 6

Default Admin
Default Administrator

2 LOGGED USERS

- Home
- Audio Input
- Audio Output
- Process
- MPX
- Multimedia
- RDS/RBDS
- Signals Explorer
- Users
- System Settings
- Save/Load Config.
 - To/From File
 - To/From Memory
 - Easy Config**
 - Quick RDS Setup**
 - Settings
- Logs
- Version Info

RT Operative Mode

RT Operative Mode

Extended Mode

Uecp Compatible

Extended Mode

RT Extended Source

RT Extended Source

SMB/SAMBA Share

REST Command

SMB/SAMBA Share

UECP Custom

ASCII Parser on UDP Port

ASCII Parser on MIB OID

Aux1 Mpx Changeover Filtered Rebroadcasting Rds Decoder

Remote Rebroadcasting Multicast Source

Extended RT Refresh Time

Extended RT Refresh Time

Off

Off

10 sec

20 sec

30 sec

40 sec

50 sec

60 sec (1 min)

70 sec

Default Admin
Default Administrator

2 LOGGED USERS

- Home
- Audio Input
- Audio Output
- Process
- MPX
- Multimedia
- RDS/RBDS
- Signals Explorer
- Users
- System Settings
- Save/Load Config.**
 - To/From File
 - To/From Memory
 - Easy Config**
 - Quick RDS Setup**
 - Settings
- Logs
- Version Info

RT+

RT+ Service will be automatically generated using every tagged data available.

Important: this service requires **3A** and **12A** groups in the group sequence list (in Standard Mode - Uecp Services page).

Auto-generated RT+

Enhanced RT+ enable

Enhanced RT+ disable

Enhanced RT+ enable

5.1.2.2 Settings

Setup Options

If you want to be notified about this quick setup menu on next session login, please mark the check below.

Setup Options

Information

Show Easy Config Menu advice on next login

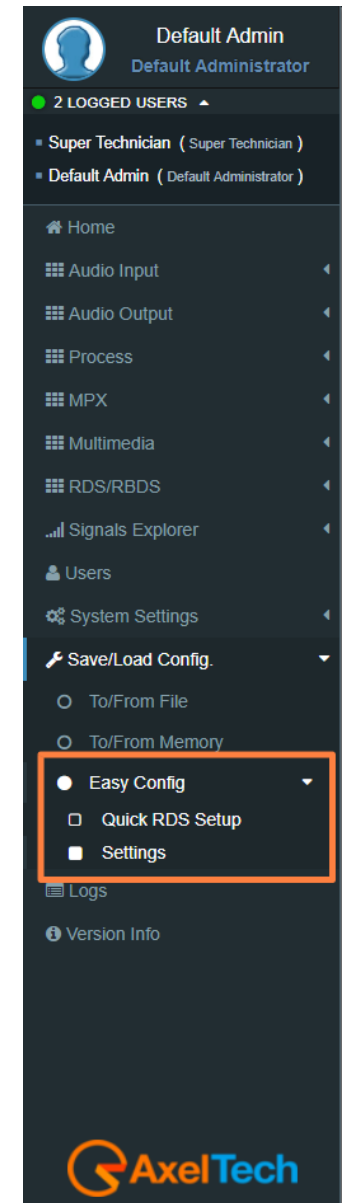

5.2 LOGS

In the Logs section, you can read for all the device Log list.

You can see four Logs Section. For every section, you can do Refresh, Load All Logs from the device beginning or you can Clear it. All user classes can click some of these three buttons.

Logs - User Permissions:

Administrator, technician, broadcaster, default administrator - Logs Read&Write, Logs Debug Hide)

Super Technician (Logs Hided, Logs Debug Read&Write)

Guest (Logs Read&Write, Logs Debug Hide)

5.2.1 USERS LOGS

In this section, you can read for the user logs changes or user logins or logouts.

5.2.2 EVENTS LOGS

In this section, you can read for the logs of all detected events if they are **unmasked** in the related section.

5.2.3 NOTIFICATIONS LOGS

In this section, you can read for the logs of sent notifications or alarms.

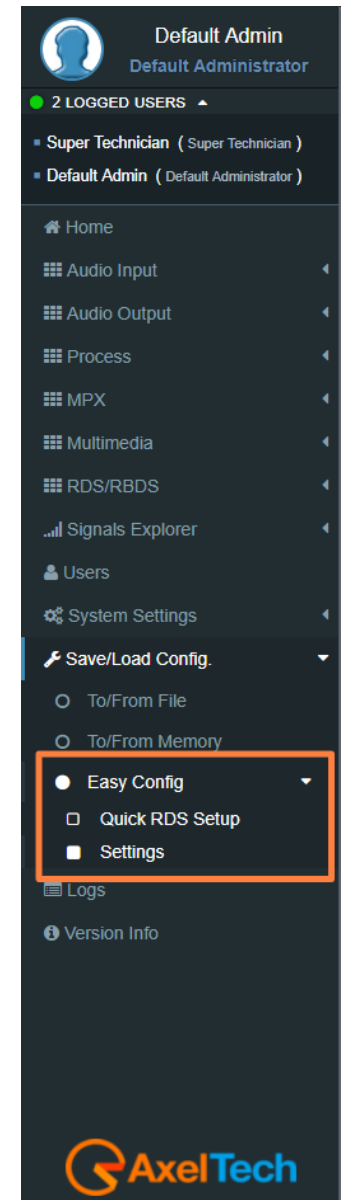
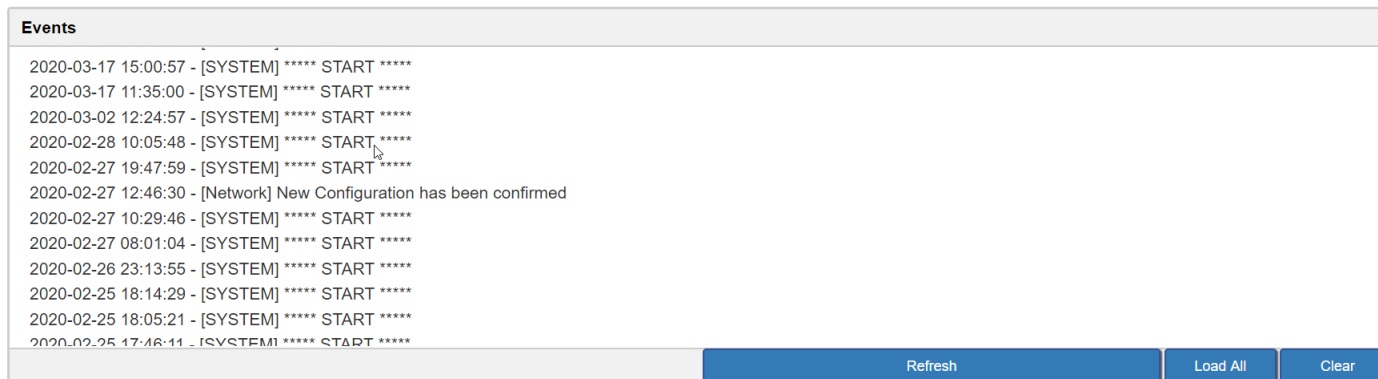

5.3 ASCII COMMANDS

By **Parser ASCII** can acquire text commands by activating the '**ASCII Commands**' mode from the software or via web browser. The ASCII commands string can be accepted also via **SNMP** sending to **OID** the "**Ascii Code**" string (see MIB for further details).

It can be used in three ways:

- Share SAMBA
- UDP Port: 15000
- SNMP OID on MIB

The **RDS** services contemplated are:

- PS, PS Scrolling
- Radiotext
- RT+
- TA/TP
- MS
- Dataset
- PTY
- PTYN

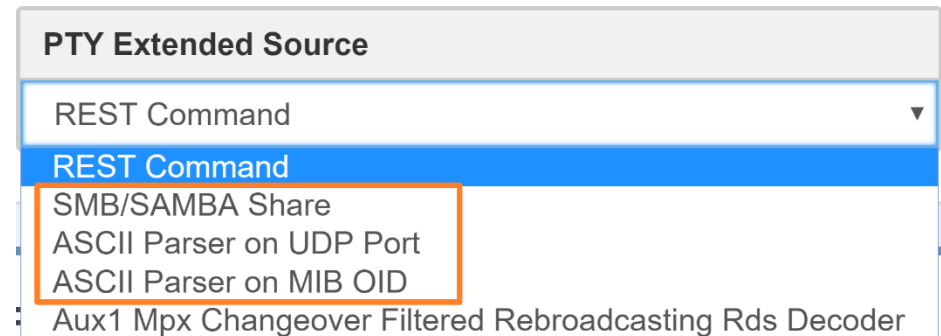

For each of them, it is possible to select the data source separately.

In the case of **SAMBA Share**, simply select the corresponding mode on the **RDS** Settings page:

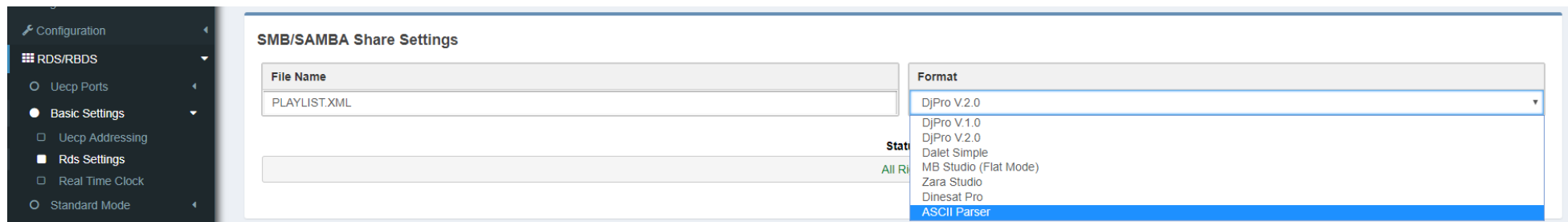

If the **UDP port** is selected, this must be enabled (always on the same page):

ASCII Parser on UDP Port Settings

<input checked="" type="checkbox"/> Active	Port 15000
--	---------------

Finally, if you choose to operate via **MIB**, there is the **OID .1.3.6.1.4.1.27295.2.3.2.9.1.0** which contains the string **aStringCmd** where you can insert commands:

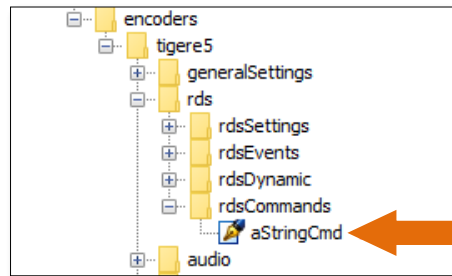

5.3.1 ASCII PARSER (DESCRIPTION OF THE PROTOCOL)

All **ASCII commands** optionally allow you to expose **SiteAddress** and **EncoderAddress**. In this case, the device only actuates the command if the values shown belong to the device's address list (see [RDS / RBDS menu > Basic Settings > UECP Addressing](#)).

Uecp Addressing (RDS/RBDS > Basic Settings)

Individual Address

Site 2	Encoder 3
-----------	--------------

Uecp Address

Site Addresses 1 🗑️	Encoder Addresses 1 🗑️
+	+

5.3.2 SYNTAX

Each command begins with a keyword that identifies it, a series of separators ',' designed to separate the parameters related to the keyword and, if the command provides it, from a string of characters enclosed by double quotes (ascii code: 34).

- Spacing characters are allowed.
- The keywords and parameters are not case-sensitive.
- The parameters must respect the sending order as described below.
- The command must end with a return (ascii code: 13).
- If the command is expected, **UECP** addressing can be added by indicating **SiteAddress** and **EncoderAddress**.

5.3.3 COMMANDS

Radiotext

Keyword:	RADIOTEXT
Parameters:	<"string max 64 characters">, [SiteAddress, EncoderAddress]
Answer:	RT OK

Example:

RADIOTEXT, "text max 64 characters" ↓

with **UECP** addressing: SiteAddress = 2, EncoderAddress = 18

RADIOTEXT, "text max 64 characters", 2, 18 ↓

PS Scroll

Keyword:	PSSCROLL
Parameters:	<RIP>,<CHARS>,<SPEED>,<"string max 64 characters">, [SiteAddress, EncoderAddress]
Answer:	PS OK

RIP: { NORIP, 1_RIP, 2_RIP, 3_RIP, 4_RIP, 5_RIP, 6_RIP, 7_RIP }

CHARS: { 1CHAR, 2CHAR, 3CHAR, 4CHAR }

SPEED: { SLOWER, NORMAL, FASTER }

Example 1:

PSSCROLL with no repetition, **PSSCROLL** of **2** characters for refresh, low speed:

PSSCROLL, NORIP, 2CHAR, SLOWER, "text max 64 characters"↓

Example 2:

PSSCROLL with **4** repetitions, **PSSCROLL** of **2** characters for refresh, normale speed:

PSSCROLL, 4_RIP, 2CHAR, NORMAL, "text max 64 characters", 2, 18 ↓

RT Plus

Keyword:	RTPLUS
Parameters:	ToggleBit, RunningBit, RTContent type 1, Start Content Type 1, Lenght Content Type 1, RTContent type 2, Start Content Type 2, Lenght Content Type 2, [SiteAddress, EncoderAddress]
Answer:	RT+ OK

ToggleBit: Inform the receiver that the item has changed

RunningBit: Inform the receiver of the validity of the item

RTContent Type1: Content type 1

Start Content Type1:	Starting position of content type 1
Length Content Type1:	Number of characters following the first defining the content type 1
RTContent Type2:	Content type 2
Start Content Type2:	Starting position of content type 2
Length Content Type2:	Number of characters following the first defining the content type 2

Example:

The following string **RT** is sent:

I	n	o	n	a	:	U	p	r	i	n	g	,	M	u	s	e	-	T	h	e	R	e	s	i	s	t	a	n	c	e	-	2	0	0	9										
0	0	0	0	0	0	0	0	0	0	1	1	1	1	1	1	1	1	1	2	2	2	2	2	2	2	2	2	3	3	3	3	3	3	3	3	3	4	4	4	4	4				
0	1	2	3	4	5	6	7	8	9	0	1	2	3	4	5	6	7	8	9	0	1	2	3	4	5	6	7	8	9	0	1	2	3	4	5	6	7	8	9	0	1	2	3	4	5

With **UECP** addressing: **Site Address = 2, Encoder Address = 18**

RTPLUS, 1, 1, 1, 8, 7, 4, 18, 3, 2, 18 ↓

Note: For more information on **RT+** consult the official **RDS** Forum document.

Dataset

Select the active **Dataset**.

Keyword:	DATASET
Parameters:	DataSet number (1 to 6), [SiteAddress, EncoderAddress]
Answer:	DS OK

Example for Dataset 1:

DATASET, 1 ↓

With **UECP** addressing:

DATASET, 1, 2, 18 ↓

TA/TP

Set the **TA/TP** of the current Dataset.

Keyword:	TATP
Parameters:	TA, TP, [SiteAddress, EncoderAddress]
Answer:	TATP OK

Example: TA OFF, TP ON

TATP, 0, 1 ↓

With **UECP** addressing: **SiteAddress** = 2, **EncoderAddress** = 18

TATP, 0, 1, 2, 18 ↓

Example: TA ON, TP ON

TATP, 1, 1 ↓

With **UECP** addressing: **SiteAddress** = 2, **EncoderAddress** = 18

TATP, 1, 1, 2, 18 ↓

PTY

Set the **Program Type**.

Keyword:	PTY
Parameters:	PTY number (0 to 31), [SiteAddress, EncoderAddress]
Answer:	PTY OK

Select **PTY** News:

PTY, 1 ↓

PTYN

Set the **Program Type Name**.

Keyword:	PTYN
Parameters:	PTYN "string max 8 characters", [SiteAddress, EncoderAddress]
Answer:	PTYN OK

Select **PTYN** "Football":

PTYN, "Football" ↓

M/S

Set the **Music/Speech**.

Keyword:	MS
Parameters:	MS number (0 to 1), [SiteAddress, EncoderAddress]
Answer:	MS OK

Select **Speech**:

MS, 0 ↓

Select **Music**:

MS, 1 ↓

6. TECHNICAL SPECS

PSU	
Power Supply	90-260 Vac / 47-63 Hz 15W
Analog Input	
Connectors	Balanced on 2 XLR – EMI Suppression
Nominal Input Level (sensitivity)	-12dBu to +13dBu Adjustable via software
Input impedance	10k Ω
Level range	-21,0 dBu to + 24,0 dBu
Input level max.	+24,0 dBu
A/D Conversion	CS4272 DAC 24bit 192KHz
CMRR input	>60 dB (20 Hz to 20 kHz)
Digital Input	
Inputs Number	2
Connectors	Balanced on 1 XLR – EMI Suppression
Input impedance	110 Ω
Format	AES3/EBU & SPDIF
Sample rate	32/44,1/48/64/88,2/96/192 kHz
Nominal input level (sensitivity)	From -0,1 dBFs to -25,0 dBFs (0,1 dB step)
Level range	0,0 dBFs ÷ -36,0 dBFs
Conversion dynamic range	124 dB (32 KHz) 126 dB (44,1 kHz) 126 dB (48 kHz) 122 dB (96 kHz)
Conversion resolution	24 bits
MPX Input	
Connector	Unbalanced on 2 BNC – EMI Suppression
Input Impedance	50K
Adjustable Nominal Input Level (Sensitivity)	Software Adjustable -9dBm to +15,0dBm
Range of Level	-21,0dBu ÷ +24,0dBu
Max Input Level	+24,0dBu
A/D Conversion	Texas PCM4202

Analog Output	
Connectors	Balanced on 2 XLR – EMI Suppression
Output impedance	47 Ω
Output Level	Adjustable software from -4 dBu to +20dBu
Level Range	-20,0 dBu to + 24,0 dBu
Output Level Max.	+ 24,0 dBu
CMRR Output	>60 dB (20 Hz - 20 kHz)
D/A Conversion	CS4272 DAC 24bit 192 kHz
Digital Output	
Outputs Number	2
Connectors	Balanced on 1 XLR – EMI Suppression
Input impedance	110 Ω
Format	AES3/EBU
Sample rate	32/44,1/48/64/88,2/96/192 KHz
Output level adjustment	From 0,0 dBFs to -30,0 dBFs (0,1dB steps)
Level range	0,0 dBFs ÷ -36,0 dBFs
Frequency range	20 Hz-20 kHz (+/- 0,025dB when processing is disabled)
MPX Output	
Connector	Unbalanced on 2 BNC – EMI Suppression
Output Impedance	10 Ω
Load Impedance	600 Ω or greater
Maximum Load Capacitance 5nF	192KHz
D/A Conversion	Texas PCM 1796
Composite output level	-9,0dBm to +15,0 dBm (0,1 dBm step)
S/N	\geq 85dB
THD	\leq 0.01%
Separation	\geq 65dB
MPX & RDS Signal	
Pilot Frequency	19 KHz +/- 1Hz
Pilot Injection	Adj from -25,0dB a -15,5dB (0,1 dB step); 6 to 18% of total deviation
Pilot Stability	\pm 10 ppm (-10 to +55°C)

Pilot Distortion	0,05% (typical)
Pilot Distortion + Noise	0,068% (on 100KHz band)
Composite out THD	0,01% (typical on the whole band)
Stereo Separation	>70 dB (typical on the whole band)
Linear Crosstalk Main to Sub / Sub to Main	>70 dB (minimum)
Digital filtering / band	30 Hz to 15 kHz (-0,1dB), 17 kHz (-70 dB), 19 kHz (-100 dB)
57 kHz (RDS/RBDS) Protection	Better than 51 dB
Pre-emphasis	Off, 50uS, 75uS (+-0,1dB)
Freq Response	±0,3 dB (30Hz-15kHz)
Operation	Mono / Stereo
MPX/RDS Output	Adj from -10,0 dB to 15,0 dB (0,1 dB step)
Signal/Noise Ratio	≥ 85 dB (on 100 kHz band)
Carrier Suppression	> 85 dB
System	
GPIO Inputs/Outputs	6 GPI / 4 GPO
Communication Port	2xRS232, 3xUSB, 1xLAN
Synchronization	Ext(Pilot Mpx)/ Int/ Auto
Synchronization Monitoring	Yes
RDS Level adjustment	Digitally controlled
Phase adjustment	Yes, 0 ÷ 359.9°
Separate outputs for RDS+MPX and for RDS only	Yes
Command to activate the RDS SCA	Yes
Side Chain Mode, Loop through mode, Bypass feature	Yes
RDS Subcarrier	100% Digitally Generated Shape
CENELEC – EN50067 compliant –	Yes
Accurate Clock Time (CT) Sync with Internet Connection	Yes
Remote TA actuation for Traffic Announcements	Yes
GPS module for automatic synchronization of the built-in Real Time Clock (RTC)	Optional (USB External)
RDS decoder for rebroadcasting RDS Data	Yes
Firmware can be upgraded in the field	Yes

Front-panel Colour TFT Display	No (Falcon X6)	Yes (Falcon X5, X7)
Data may be entered on-site with Front-panel Buttons	No (Falcon X6)	Yes (Falcon X5, X7)
Front Panel LEDs	40	
Operating Temperature	0°C ÷ 50°C	
DIGITAL INPUT - MPX		
Connectors	Balanced on 1 XLR – EMI Suppression	
Input impedance	110 Ω	
Format	AES3/EBU & SPDIF	
Sample rate	192 kHz	
Nominal input level (sensitivity)	From -0,1 dBFs to -25,0 dBFs (0,1 dB step)	
Level range	0,0 dBFs to -36,0 dBFs	
Conversion dynamic range	124 dB (32 kHz) 126 dB (44,1 kHz) 126 dB (48 kHz) 122 dB (96 kHz)	
Conversion resolution	24 bits	
MPX & RDS SIGNAL		
Pilot frequency	19 kHz +/- 1 Hz	
Pilot injection	-25,0 dB ÷ 15,5 dB (step 0,1) 6-18% total deviation	
Pilot stability	±10 ppm (-10° to +55° C)	
Pilot distortion	0,05 % (typical)	
Distortion + Pilot noise	0,068 % (on the 100 kHz band)	
External composite THD	0,005 % (typical on the whole band)	
Stereo separation	> 70 dB (typical on the whole band)	
Linear crosstalk	≤ -80 dB (for a 100% modulation)	
main>sub and sub>main crosstalk	> 65 dB (at least)	
Filtering / digital band	30 Hz to 15 kHz (-0,1 dB), 17 kHz (-70 dB), 19 kHz (-100 dB)	
Protect. 57 kHz subcarrier (RDS/RBDS)	Better than 51 dB	
Pre-emphasis	Off, 50 μS, 75 μS (+0,1dB)	
Frequency response	±0,3 dB (30 Hz to 15 kHz)	
Operating mode	Mono /Stereo	
MPX/RDS Output	Adjustable from -10,0 dB to 15,0 dB (step 0,1 dB)	
Signal/Noise Ratio	> 90 dB (on the 100 kHz band)	
Carrier Suppression	>85 dB	

RDS Features	
Group supported	All
Group Sequence	Configurable
PS	8 DSN x MAIN+10 PSN
PI	8 DSN x MAIN+10 PSN
PIN & PTY	RDS/RBDS
AF Method A	up to 1024 (64 lists)
AF Method B	up to 1024 (64 lists)
RT	Yes, 32 messages
RT rate adjustment	Group Sequence
RT+ for songs and content tagging	Yes
TP	Yes
TA Control	Command, Software, GPI
PTYN	Yes
EON	10 PSN
CT	Yes
TMC, EWS, IH, TDC	Yes
Free Format Groups (FFG)	Yes
Open Data Application (ODA)	Yes
PS Scrolling	Yes
Scrolling by characters, by word, auto centre, truncate long words	Yes (Characters – from 1 up to 8)
BACKUP PLAYER	
Physical support	USB Flash Drive, microSD CARD (max 64GB)
Audio file format	MP3, WAV
Sample Rate	32 44,1 48 64 96 kHz
Communication	
Connection with Automation Software	Yes
Network Connectivity	4 TCP ports / 4 UDP / 1 SNMP
PSN Scheduler	Yes
Configuration Software	Web Server, FTP
Password Protection	Yes

ASCII Protocol	Configuration Messages
REST Command	Yes
Alert notifications on user-defined events via SNMP traps or E-mails	Yes
Embedded SNMP agent permitting active management tasks	Yes
Supported Network Protocols	HTTP, SMTP, UDP, TCP, NTP, FTP
UECP Protocol	EBU SPB490 Ver.7.05
PI Calculator	Yes
RDS 2.0 Ready	Yes
Dimensions	
Dimensions (W; H; D)	485 x 44 x 240 mm
Weight	3.5Kg

7. WEEE DIRECTIVE – INFORMATIVA RAEE



In line with EU Directive 2002/96/EC for waste electrical and electronic equipment (WEEE), this electrical product must not be disposed of as unsorted municipal waste. Please dispose of this product by returning it to the point of sale or to your local municipal collection point for recycling.

In Übereinstimmung mit der Richtlinie 2002/96/EG des Europäischen Parlaments und des Rates über Elektro- und Elektronik-Altgeräte (WEEE) darf dieses Elektrogerät nicht im normalen Hausmüll oder dem Gelben Sack entsorgt werden. Wenn Sie dieses Produkt entsorgen möchten, bringen Sie es bitte zur Verkaufsstelle zurück oder zum Recycling-Sammelpunkt Ihrer Gemeinde.

Conformément à la Directive 2002/96/EC sur les déchets d'équipements électriques et électroniques (DEEE), ce produit électrique ne doit en aucun cas être mis au rebut sous forme de déchet municipal non trié. Veuillez vous débarrasser de ce produit en le renvoyant à son point de vente ou au point de ramassage local dans votre municipalité, à des fins de recyclage.

In navolging van richtlijn 2002/96/EG van het Europees Parlement en de Raad betreffende afgedankte elektrische en elektronische apparatuur (AEEA) mag dit elektrische product niet als ongescheiden huisvuil worden weggedaan. Breng dit product terug naar de plaats van aankoop of naar het gemeentelijke afvalinzamelingspunt voor recycling.

In ottemperanza alla Direttiva UE 2002/96/EC sui rifiuti di apparecchiature elettriche ed elettroniche (RAEE), questo prodotto elettrico non deve essere smaltito come rifiuto municipale misto. Si prega di smaltire il prodotto riportandolo al punto vendita o al punto di raccolta municipale locale per un opportuno riciclaggio.

De conformidad con la Directiva 2002/96/CE de la UE sobre residuos de aparatos eléctricos y electrónicos (RAEE), este producto eléctrico no puede desecharse con el resto de residuos no clasificados. Deshágase de este producto devolviéndolo al punto de venta o a un punto de recogida municipal para su reciclaje.

I henhold til EU-direktiv 2002/96/EF om affald af elektrisk og elektronisk udstyr (WEEE) må dette udstyr ikke bortskaffes som usorteret husholdningsaffald. Bortskaf dette produkt ved at returnere det til salgsstedet eller til det lokale indsamlingssted, så det kan genbruges.

I linje med EU-direktiv 2002/96/EG om avfall som utgörs av eller innehåller elektriska eller elektroniska produkter (WEEE) får denna elektriska produkt inte bortskaffas som osorterat kommunalt avfall. Bortskaffa den i stället genom att lämna in den på försäljningsstället eller din lokala återvinningsstation.

EU:n sähkö- ja elektroniikkalaiteromudirektiivin (2002/96/EY) mukaisesti tätä elektroniikkalaitetta ei saa laittaa lajittelemattoman yhdyskuntajätteen sekaan. Hävitä laite palauttamalla se ostopaikkaan tai viemällä se elektroniikkaromun keräyspisteeseen.

De acordo com a Directiva Europeia 2002/96/EC sobre resíduos sólidos de equipamento eléctrico e electrónico (WEEE), este produto eléctrico não pode ser deixado fora juntamente com o lixo municipal indiferenciado. Por favor, no final da vida útil deste produto, devolva-o ao estabelecimento de aquisição, ou entregue no local de recolha apropriado para reciclagem designado pelo seu município.

V souladu se smrnici EU . 2002/96/ES o odpadních elektrických a elektronických zařizeniích (OEEZ) se tento elektrický výrobek nesmí likvidovat jako netříděný komunální odpad. Při likvidaci výrobek vraťte prodejci nebo ho odevzdejte k recyklaci do komunálního sběrného zařízení.

Vastavalt EL direktiivile 2002/96/EÜ, mis käsitleb elektri- ja elektroonikaseadmete jäätmeid (WEEE), ei või antud toodet visata majapidamisjäätmete hulka. Palun tagastage antud toode taaskasutamise eesmärgil müügipunkti või kohaliku piirkonna jäätmekogumise punkti.

V súlade so smernicou 2002/96/ES o odpade z elektrických a elektronických zariadení (OEEZ) sa toto elektrické zariadenie nesmie odstranovať ako netriedený komunálny odpad. Výrobok odstráňte jeho vrátením v mieste nákupu alebo odovzdaním v miestnom zbernom zariadení na recyklovanie.

V súlade so smernicou 2002/96/ES o odpade z elektrických a elektronických zariadení (OEEZ) sa toto elektrické zariadenie nesmie odstranovať ako netriedený komunálny odpad. Výrobok odstráňte jeho vrátením v mieste nákupu alebo odovzdaním v miestnom zbernom zariadení na recyklovanie.

8. WARRANTY

The manufacturer offers a one-year warranty ex-works. Do not open the equipment. Any breaking of the seals will result in forfeiture of the same. The manufacturer is not liable for damages of any kind arising from, or in connection with, the use of the wrong product.

DECLARATION OF CONFORMITY

Manufacturer: AXEL TECHNOLOGY S.r.l.
Company title: VIA C. DI SABBIUNO 6/F - 40011 ANZOLA EMILIA - BOLOGNA ITALY

DECLARES UNDER ITS OWN RESPONSIBILITY THAT THE FOLLOWING EQUIPMENT

MODEL: FALCON X5

**DESCRIPTION: FM/DAB+/HDRadio/WEB/DRM Digital Audio Processor 5 bands. 1RU.
Analog, digital AES. 2x MPX out. SD slot to store files for audio backup. LCD display.
IS COMPLIANT**

To the requirements and all characteristics enacted from Community Directive:

1. **2014/30/UE “EMC” Electromagnetic Compatibility**
2. **2014/35/UE “LDV” Low Voltage Directive**
3. **2011/65/UE “on the restriction of the use of certain hazardous substances in electrical and electronic equipment (RoHS 2)”**

and following Harmonized Standards:

- √ **EN 55103-1:2009** Electromagnetic compatibility. Product family standard for audio, video, audio-visual and entertainment lighting control apparatus for professional use. Emissions.
- √ **EN 55103-2:2009** Electromagnetic compatibility. Product family standard for audio, video, audio-visual and entertainment lighting control apparatus for professional use. Immunity.
- √ **EN 60065:2016** Audio, video and similar electronic apparatus. Safety requirements.
- √ **EN 61000-6-1:2007** Electromagnetic compatibility. Generic standards. Immunity for residential, commercial and light-industrial environments.
- √ **EN 61000-6-3:2007+A1:2011** Electromagnetic compatibility. Generic standards. Emission standard for residential, commercial and light-industrial environments.
- √ **EN 60950-1:2006+A2:2013** Information technology equipment. Safety. General requirements.
- √ **EN 55024:2010** Information technology equipment. Immunity characteristics. Limits and methods of measurement.
- √ **EN 50581:2012** - Technical documentation for the assessment of electrical and electronic products with respect to the restriction of hazardous substances.
- √ **EN 55032:2015** - Electromagnetic compatibility of multimedia equipment. Emission Requirements.
- √ **EN 55024:2010+A1:2015** - Information technology equipment. Immunity characteristics. Limits and methods of measurement.

Remark: The present product must be installed as showed in the installation manual provided together with the equipment and used at the sole scope for wich it has been manufactured.

Anzola Emilia (BO) Italy, 16/10/2019

C.E.O.
Giuseppe Vaccari



DICHIARAZIONE DI CONFORMITA'

Nome Fabbricante: AXEL TECHNOLOGY S.r.l.
Ragione Sociale: VIA C. DI SABBIUNO 6/F - 40011 ANZOLA EMILIA - BOLOGNA ITALY

DICHIARA SOTTO LA PROPRIA RESPONSABILITÀ CHE IL PRODOTTO

MODELLO: **FALCON X5**

DESCRIZIONE: FM/DAB+/HDRadio/WEB/DRM Digital Audio Processor 5 bands. 1RU. Analog, digital AES. 2x MPX out. SD slot to store files for audio backup. LCD display.

RISPETTA

i requisiti essenziali e tutte le caratteristiche richiamate dalla Direttiva comunitaria:

1. **2014/30/UE "EMC" Compatibilità Elettromagnetica**
2. **2014/35/UE "LDV" Bassa Tensione**
3. **2011/65/UE "sulla restrizione dell'uso di determinate sostanze pericolose nelle apparecchiature elettriche ed elettroniche (RoHS 2)"**

e alle seguenti normative tecniche armonizzate:

- √ **EN 55103-1:2009** Norme di famiglie di prodotto per apparecchi audio, video, audiovisivi e di comando di luci da intrattenimento per uso professionale - Parte 1: Emissione
- √ **EN 55103-2:2009** Norme di famiglie di prodotto per apparecchi audio, video, audiovisivi e di comando di luci da intrattenimento per uso professionale - Parte 2: Immunità
- √ **EN 60065:2016** Apparecchi audio, video e apparecchi elettronici simili Requisiti di sicurezza.
- √ **EN 61000-6-1:2007** – EMC – Immunità per ambienti residenziali, commerciali e industria leggera.
- √ **EN 61000-6-3:2007+A1:2011** – EMC – Emissione per ambienti residenziali, commerciali e industria leggera.
- √ **EN 60950-1:2006+A2:2013** – Sicurezza degli apparati ITE (Information Technology Equipment)
- √ **EN 55024:2010** Apparecchiature per la tecnologia dell'informazione - Caratteristiche di immunità Limiti e metodi di misura.
- √ **EN 50581:2012** - Documentazione tecnica per la valutazione dei prodotti elettrici ed elettronici in relazione alla restrizione delle sostanze pericolose.
- √ **EN 55032:2015** - Compatibilità elettromagnetica di apparecchiature multimediali - Requisiti di emissione.
- √ **EN 55024:2010+A1:2015** - Apparecchiature per la tecnologia dell'informazione - Caratteristiche di immunità - Limiti e metodi di misura.

Nota: il presente prodotto deve essere installato come previsto dal manuale d'uso fornito a corredo dell'apparato ed utilizzato ai fini del servizio per il quale è stato fabbricato e destinato.

Anzola Emilia (BO) Italy, 16/10/2019

Presidente del C.d.A.

Giuseppe Vaccari



DECLARATION OF CONFORMITY

Manufacturer: AXEL TECHNOLOGY S.r.l.
Company title: VIA C. DI SABBIUNO 6/F - 40011 ANZOLA EMILIA - BOLOGNA ITALY

DECLARES UNDER ITS OWN RESPONSIBILITY THAT THE FOLLOWING EQUIPMENT

MODEL: FALCON X6

DESCRIPTION: FM/DAB+/HDRadio/WEB/DRM Digital Audio Processor 5 bands. 1RU. Analog, digital AES and streaming I/O. 2x MPX out. Audio and MPX changeover. SD slot to store files for audio backup.

IS COMPLIANT

To the requirements and all characteristics enacted from Community Directive:

1. **2014/30/UE “EMC” Electromagnetic Compatibility**
2. **2014/35/UE “LDV” Low Voltage Directive**
3. **2011/65/UE “on the restriction of the use of certain hazardous substances in electrical and electronic equipment (RoHS 2)”**

and following Harmonized Standards:

- √ **EN 55103-1:2009** Electromagnetic compatibility. Product family standard for audio, video, audio-visual and entertainment lighting control apparatus for professional use. Emissions.
- √ **EN 55103-2:2009** Electromagnetic compatibility. Product family standard for audio, video, audio-visual and entertainment lighting control apparatus for professional use. Immunity.
- √ **EN 60065:2016** Audio, video and similar electronic apparatus. Safety requirements.
- √ **EN 61000-6-1:2007** Electromagnetic compatibility. Generic standards. Immunity for residential, commercial and light-industrial environments.
- √ **EN 61000-6-3:2007+A1:2011** Electromagnetic compatibility. Generic standards. Emission standard for residential, commercial and light-industrial environments.
- √ **EN 60950-1:2006+A2:2013** Information technology equipment. Safety. General requirements.
- √ **EN 55024:2010** Information technology equipment. Immunity characteristics. Limits and methods of measurement.
- √ **EN 50581:2012** - Technical documentation for the assessment of electrical and electronic products with respect to the restriction of hazardous substances.
- √ **EN 55032:2015** - Electromagnetic compatibility of multimedia equipment. Emission Requirements.
- √ **EN 55024:2010+A1:2015** - Information technology equipment. Immunity characteristics. Limits and methods of measurement.

Remark: The present product must be installed as showed in the installation manual provided together with the equipment and used at the sole scope for wich it has been manufactured.

Anzola Emilia (BO) Italy, 16/10/2019

C.E.O.
Giuseppe Vaccari

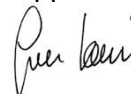

DICHIARAZIONE DI CONFORMITA'

Nome Fabbricante: AXEL TECHNOLOGY S.r.l.
Ragione Sociale: VIA C. DI SABBIUNO 6/F - 40011 ANZOLA EMILIA - BOLOGNA ITALY

DICHIARA SOTTO LA PROPRIA RESPONSABILITÀ CHE IL PRODOTTO

MODELLO: **FALCON X6**

DESCRIZIONE: **FM/DAB+/HDRadio/WEB/DRM Digital Audio Processor 5 bands. 1RU. Analog, digital AES and streaming I/O. 2x MPX out. Audio and MPX changeover. SD slot to store files for audio backup.**

RISPETTA

i requisiti essenziali e tutte le caratteristiche richiamate dalla Direttiva comunitaria:

1. **2014/30/UE "EMC" Compatibilità Elettromagnetica**
2. **2014/35/UE "LDV" Bassa Tensione**
3. **2011/65/UE "sulla restrizione dell'uso di determinate sostanze pericolose nelle apparecchiature elettriche ed elettroniche (RoHS 2)"**

e alle seguenti normative tecniche armonizzate:

- √ **EN 55103-1:2009** Norme di famiglie di prodotto per apparecchi audio, video, audiovisivi e di comando di luci da intrattenimento per uso professionale - Parte 1: Emissione
- √ **EN 55103-2:2009** Norme di famiglie di prodotto per apparecchi audio, video, audiovisivi e di comando di luci da intrattenimento per uso professionale - Parte 2: Immunità
- √ **EN 60065:2016** Apparecchi audio, video e apparecchi elettronici simili Requisiti di sicurezza.
- √ **EN 61000-6-1:2007** – EMC – Immunità per ambienti residenziali, commerciali e industria leggera.
- √ **EN 61000-6-3:2007+A1:2011** – EMC – Emissione per ambienti residenziali, commerciali e industria leggera.
- √ **EN 60950-1:2006+A2:2013** – Sicurezza degli apparati ITE (Information Technology Equipment)
- √ **EN 55024:2010** Apparecchiature per la tecnologia dell'informazione - Caratteristiche di immunità Limiti e metodi di misura.
- √ **EN 50581:2012** - Documentazione tecnica per la valutazione dei prodotti elettrici ed elettronici in relazione alla restrizione delle sostanze pericolose.
- √ **EN 55032:2015** - Compatibilità elettromagnetica di apparecchiature multimediali - Requisiti di emissione.
- √ **EN 55024:2010+A1:2015** - Apparecchiature per la tecnologia dell'informazione - Caratteristiche di immunità - Limiti e metodi di misura.

Nota: il presente prodotto deve essere installato come previsto dal manuale d'uso fornito a corredo dell'apparato ed utilizzato ai fini del servizio per il quale è stato fabbricato e destinato.

Anzola Emilia (BO) Italy, 16/10/2019

Presidente del C.d.A.

Giuseppe Vaccari



DECLARATION OF CONFORMITY

Manufacturer: AXEL TECHNOLOGY S.r.l.
Company title: VIA C. DI SABBIUNO 6/F - 40011 ANZOLA EMILIA - BOLOGNA ITALY

DECLARES UNDER ITS OWN RESPONSIBILITY THAT THE FOLLOWING EQUIPMENT

MODEL: FALCON X7

DESCRIPTION: FM/DAB+/HDRadio/WEB/DRM Digital Audio Processor 5 bands. 1RU. Analog, digital AES and streaming I/O. 2x MPX out. Audio and MPX changeover. SD slot to store files for audio backup. LCD display.

IS COMPLIANT

To the requirements and all characteristics enacted from Community Directive:

1. **2014/30/UE “EMC” Electromagnetic Compatibility**
2. **2014/35/UE “LDV” Low Voltage Directive**
3. **2011/65/UE “on the restriction of the use of certain hazardous substances in electrical and electronic equipment (RoHS 2)”**

and following Harmonized Standards:

- √ **EN 55103-1:2009** Electromagnetic compatibility. Product family standard for audio, video, audio-visual and entertainment lighting control apparatus for professional use. Emissions.
- √ **EN 55103-2:2009** Electromagnetic compatibility. Product family standard for audio, video, audio-visual and entertainment lighting control apparatus for professional use. Immunity.
- √ **EN 60065:2016** Audio, video and similar electronic apparatus. Safety requirements.
- √ **EN 61000-6-1:2007** Electromagnetic compatibility. Generic standards. Immunity for residential, commercial and light-industrial environments.
- √ **EN 61000-6-3:2007+A1:2011** Electromagnetic compatibility. Generic standards. Emission standard for residential, commercial and light-industrial environments.
- √ **EN 60950-1:2006+A2:2013** Information technology equipment. Safety. General requirements.
- √ **EN 55024:2010** Information technology equipment. Immunity characteristics. Limits and methods of measurement.
- √ **EN 50581:2012** - Technical documentation for the assessment of electrical and electronic products with respect to the restriction of hazardous substances.
- √ **EN 55032:2015** - Electromagnetic compatibility of multimedia equipment. Emission Requirements.
- √ **EN 55024:2010+A1:2015** - Information technology equipment. Immunity characteristics. Limits and methods of measurement.

Remark: The present product must be installed as showed in the installation manual provided together with the equipment and used at the sole scope for wich it has been manufactured.

Anzola Emilia (BO) Italy, 16/10/2019

C.E.O.
Giuseppe Vaccari



DICHIARAZIONE DI CONFORMITA'

Nome Fabbricante: AXEL TECHNOLOGY S.r.l.
Ragione Sociale: VIA C. DI SABBIUNO 6/F - 40011 ANZOLA EMILIA - BOLOGNA ITALY

DICHIARA SOTTO LA PROPRIA RESPONSABILITÀ CHE IL PRODOTTO

MODELLO: **FALCON X7**

DESCRIZIONE: FM/DAB+/HDRadio/WEB/DRM Digital Audio Processor 5 bands. 1RU. Analog, digital AES and streaming I/O. 2x MPX out. Audio and MPX changeover. SD slot to store files for audio backup. LCD display.

RISPETTA

i requisiti essenziali e tutte le caratteristiche richiamate dalla Direttiva comunitaria:

1. **2014/30/UE "EMC" Compatibilità Elettromagnetica**
2. **2014/35/UE "LDV" Bassa Tensione**
3. **2011/65/UE "sulla restrizione dell'uso di determinate sostanze pericolose nelle apparecchiature elettriche ed elettroniche (RoHS 2)"**

e alle seguenti normative tecniche armonizzate:

- ✓ **EN 55103-1:2009** Norme di famiglie di prodotto per apparecchi audio, video, audiovisivi e di comando di luci da intrattenimento per uso professionale - Parte 1: Emissione
- ✓ **EN 55103-2:2009** Norme di famiglie di prodotto per apparecchi audio, video, audiovisivi e di comando di luci da intrattenimento per uso professionale - Parte 2: Immunità
- ✓ **EN 60065:2016** Apparecchi audio, video e apparecchi elettronici simili Requisiti di sicurezza.
- ✓ **EN 61000-6-1:2007** – EMC – Immunità per ambienti residenziali, commerciali e industria leggera.
- ✓ **EN 61000-6-3:2007+A1:2011** – EMC – Emissione per ambienti residenziali, commerciali e industria leggera.
- ✓ **EN 60950-1:2006+A2:2013** – Sicurezza degli apparati ITE (Information Technology Equipment)
- ✓ **EN 55024:2010** Apparecchiature per la tecnologia dell'informazione - Caratteristiche di immunità Limiti e metodi di misura.
- ✓ **EN 50581:2012** - Documentazione tecnica per la valutazione dei prodotti elettrici ed elettronici in relazione alla restrizione delle sostanze pericolose.
- ✓ **EN 55032:2015** - Compatibilità elettromagnetica di apparecchiature multimediali - Requisiti di emissione.
- ✓ **EN 55024:2010+A1:2015** - Apparecchiature per la tecnologia dell'informazione - Caratteristiche di immunità - Limiti e metodi di misura.

Nota: il presente prodotto deve essere installato come previsto dal manuale d'uso fornito a corredo dell'apparato ed utilizzato ai fini del servizio per il quale è stato fabbricato e destinato.

Anzola Emilia (BO) Italy, 16/10/2019

Presidente del C.d.A.

Giuseppe Vaccari



DECLARATION OF CONFORMITY

Manufacturer: AXEL TECHNOLOGY S.r.l.
Company title: VIA C. DI SABBIUNO 6/F - 40011 ANZOLA EMILIA - BOLOGNA ITALY

DECLARES UNDER ITS OWN RESPONSIBILITY THAT THE FOLLOWING EQUIPMENT

MODEL: FALCON D7

DESCRIPTION: TV/DAB+/HDRadio/WEB Digital Audio Processor 5 bands. 1RU. Loudness Control ITU-1770. Analog, digital AES e streaming I/O. SD slot per audio backup. LCD display.

IS COMPLIANT

To the requirements and all characteristics enacted from Community Directive:

1. **2014/30/UE “EMC” Electromagnetic Compatibility**
2. **2014/35/UE “LDV” Low Voltage Directive**
3. **2011/65/UE “on the restriction of the use of certain hazardous substances in electrical and electronic equipment (RoHS 2)”**

and following Harmonized Standards:

- √ **EN 55103-1:2009** Electromagnetic compatibility. Product family standard for audio, video, audio-visual and entertainment lighting control apparatus for professional use. Emissions.
- √ **EN 55103-2:2009** Electromagnetic compatibility. Product family standard for audio, video, audio-visual and entertainment lighting control apparatus for professional use. Immunity.
- √ **EN 60065:2016** Audio, video and similar electronic apparatus. Safety requirements.
- √ **EN 61000-6-1:2007** Electromagnetic compatibility. Generic standards. Immunity for residential, commercial and light-industrial environments.
- √ **EN 61000-6-3:2007+A1:2011** Electromagnetic compatibility. Generic standards. Emission standard for residential, commercial and light-industrial environments.
- √ **EN 60950-1:2006+A2:2013** Information technology equipment. Safety. General requirements.
- √ **EN 55024:2010** Information technology equipment. Immunity characteristics. Limits and methods of measurement.
- √ **EN 50581:2012** - Technical documentation for the assessment of electrical and electronic products with respect to the restriction of hazardous substances.
- √ **EN 55032:2015** - Electromagnetic compatibility of multimedia equipment. Emission Requirements.
- √ **EN 55024:2010+A1:2015** - Information technology equipment. Immunity characteristics. Limits and methods of measurement.

Remark: The present product must be installed as showed in the installation manual provided together with the equipment and used at the sole scope for wich it has been manufactured.

Anzola Emilia (BO) Italy, 15/01/2021

C.E.O.
Giuseppe Vaccari



DICHIARAZIONE DI CONFORMITA'

Nome Fabbricante: AXEL TECHNOLOGY S.r.l.
Ragione Sociale: VIA C. DI SABBIUNO 6/F - 40011 ANZOLA EMILIA - BOLOGNA ITALY

DICHIARA SOTTO LA PROPRIA RESPONSABILITÀ CHE IL PRODOTTO

MODELLO: **FALCON D7**

DESCRIZIONE: TV/DAB+/HDRadio/WEB Digital Audio Processor 5 bands. 1RU. Loudness Control ITU-1770. Analog, digital AES e streaming I/O. SD slot per audio backup. LCD display.

RISPETTA

i requisiti essenziali e tutte le caratteristiche richiamate dalla Direttiva comunitaria:

1. **2014/30/UE "EMC" Compatibilità Elettromagnetica**
2. **2014/35/UE "LDV" Bassa Tensione**
3. **2011/65/UE "sulla restrizione dell'uso di determinate sostanze pericolose nelle apparecchiature elettriche ed elettroniche (RoHS 2)"**

e alle seguenti normative tecniche armonizzate:

- ✓ **EN 55103-1:2009** Norme di famiglie di prodotto per apparecchi audio, video, audiovisivi e di comando di luci da intrattenimento per uso professionale - Parte 1: Emissione
- ✓ **EN 55103-2:2009** Norme di famiglie di prodotto per apparecchi audio, video, audiovisivi e di comando di luci da intrattenimento per uso professionale - Parte 2: Immunità
- ✓ **EN 60065:2016** Apparecchi audio, video e apparecchi elettronici simili Requisiti di sicurezza.
- ✓ **EN 61000-6-1:2007** – EMC – Immunità per ambienti residenziali, commerciali e industria leggera.
- ✓ **EN 61000-6-3:2007+A1:2011** – EMC – Emissione per ambienti residenziali, commerciali e industria leggera.
- ✓ **EN 60950-1:2006+A2:2013** – Sicurezza degli apparati ITE (Information Technology Equipment)
- ✓ **EN 55024:2010** Apparecchiature per la tecnologia dell'informazione - Caratteristiche di immunità Limiti e metodi di misura.
- ✓ **EN 50581:2012** - Documentazione tecnica per la valutazione dei prodotti elettrici ed elettronici in relazione alla restrizione delle sostanze pericolose.
- ✓ **EN 55032:2015** - Compatibilità elettromagnetica di apparecchiature multimediali - Requisiti di emissione.
- ✓ **EN 55024:2010+A1:2015** - Apparecchiature per la tecnologia dell'informazione - Caratteristiche di immunità - Limiti e metodi di misura.

Nota: il presente prodotto deve essere installato come previsto dal manuale d'uso fornito a corredo dell'apparato ed utilizzato ai fini del servizio per il quale è stato fabbricato e destinato.

Anzola Emilia (BO) Italy, 15/01/2021

Presidente del C.d.A.

Giuseppe Vaccari

