

MOZA Pro

User manual

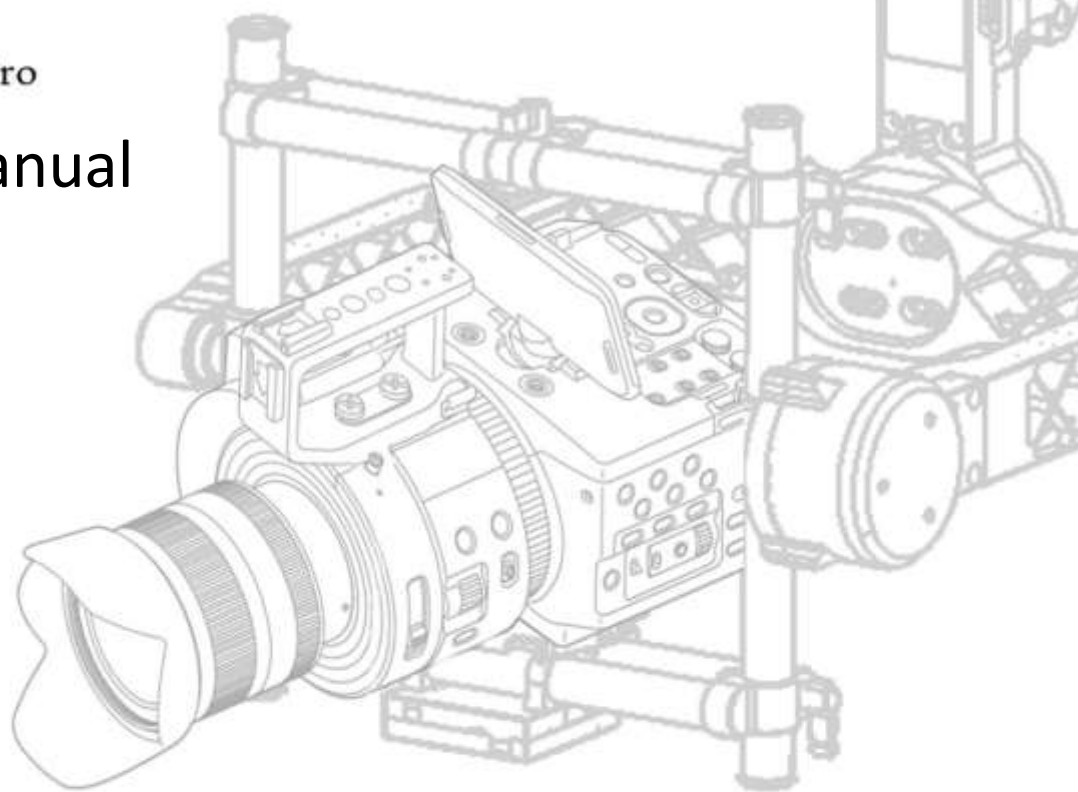

GUDSEN

User note

Congratulations on your purchase of the MOZA series 3-axis camera gimbal! These instructions will help you to successfully install and correctly use this product and its accessories. Please read these instructions carefully before using this product.

Announcements

1. We have done our best to create accurate and complete instructions, but minor errors and omissions may still exist. When in doubt, please refer to the actual product.
 2. Gudsen is responsible for the warranty and maintenance of the product itself. However, Gudsen assumes no liability for damage or injuries incurred directly or indirectly from misuse of the product.
 3. By reading this disclaimer, you also acknowledge that:
 - (1) Any part of this disclaimer is subject to change without prior notice. Please refer to www.gudsen.com for the latest version.
 - (2) Gudsen reserves the right of final interpretation of this disclaimer.
-

Contents

Terms & Conditions

User Note	1
In the Box	2
Safety Instructions	3

Operation Guide

MOZA Pro Diagram	4
Installation	6
Balancing	9
Getting Started	11

Using the Gimbal

Follow Modes	13
Operation Modes	14
Gimbal Operation	15
Camera	16

Thumb Controller

Thumb Controller Diagram	17
Button Instructions	18
Using the Main Menu	19
Settings	20
Menu Function List	22

Software and APP

Downloading and Installation	28
Connection with MOZA	29
Parameters and Functions	30
Sensor Calibration	36
Firmware Upgrade on Gimbal	37
Firmware Upgrade on Thumb Controller	38
APP Connection with MOZA	45
Using the APP	46

Specifications

MOZA Pro Specifications	43
Thumb Controller Specifications	43
Intelligent Battery	43
Charger Battery	43

FAQs	44
------------	----

Maintenance	46
-------------------	----

Product Introduction

Designed for professional film production, the MOZA Pro is an intelligent 3-axis electronic gyroscope stabilizer made by Gudsen Technology to create smooth video.

MOZA Pro has a maximum payload of 10kg that can support most large cinema cameras.

The wireless thumb controller designed exclusively by Gudsen Technology works perfectly with MOZA Pro for camera recording and focus control.

Tuning MOZA Pro is possible via the MOZA Assistant. The Assistant works on multiple operating systems, including iOS, Android, Windows, and Mac OS X.

In the Box

Gimbal X 1
Stand X 1
Handle Bar X 1
Accessory Mount X 2
Intelligent Battery X 1
Battery Charger X 1
Pan Extension Arm X 1 (Assembled)
Roll Extension Arm X 1 (Assembled)
Counterweight Set (Securing Rods & Counterweights) X 1 (Optional)
Wireless Thumb Controller (accessory mount assembled) X 1
 Wireless Thumb Controller x 1
 Accessory Mount x 1
 1/4 Screw x 1
Quick Install Assembly X 1
 Camera Mounting Plate x 1
 1/4" Camera Screw x 2
 3/8" Camera Screw x 1
Tool Bag X 1
 Follow Focus Assembly Tube x 2
 1/4" Screw x 1
 3/8" Screw x 1
 Lens Support x1
 L2/L2.5/L3 Allen Wrench x 3
 Flannelette Bag x 1
Cables X 5
 Micro USB Cable x 1
 Mini to Mini USB Cable x 1
 Mini to Micro USB Cable x1
 Mini to 2.5mm Control Cable*1
 DC 3.5mm to D-TAP Power Cable*1
User Manual X 1
Wrapper X 1
 Carrying Case x 1
 First Layer EVA Cotton x 1
 Second Layer EVA Cotton x 1
 Cotton Interlayer x 1

Safety Instructions

1. The MOZA Pro is a precision machine, but it is not waterproof. Keep it away from rain and other damp conditions. Do not place it on items containing liquid or store any items on it that contain liquid.
 2. Do not use this product at a gas station, filling station, or any other location that bans the use of electronic devices.
 3. Do not use the MOZA Pro at hospitals, on airplanes, etc. It contains wireless equipment.
 4. Keep this product away from children to avoid a choking hazard. The MOZA Pro is equipped with small parts and accessories.
 5. The MOZA Lite2 and thumb controller are powered by a large-capacity lithium battery. If misused, the battery could explode, resulting in fire and possible chemical burns. Please observe the following precautions:
 - (1). Do not dismantle the battery.
 - (2). Do not crush, beat, throw, stomp on, or shake the battery.
 - (3). Do not short-circuit the battery. Keep the MOZA Pro away from metal and other conductors.
 - (4). Store the battery in an environment in which the temperature is lower 65°C and keep it out of direct sunlight.
 - (5). Keep the battery away from fire.
 - (6). Do not use a damaged or leaking battery.
 - (7). Use the original battery and charger supplied here. Do not use other batteries charger. Or use this battery or charger with other machines. Gudsen has no responsibilities in any of the above situations.
-

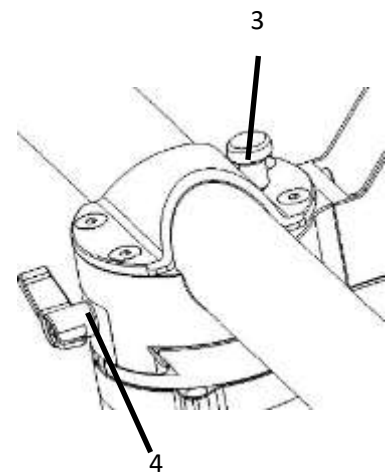
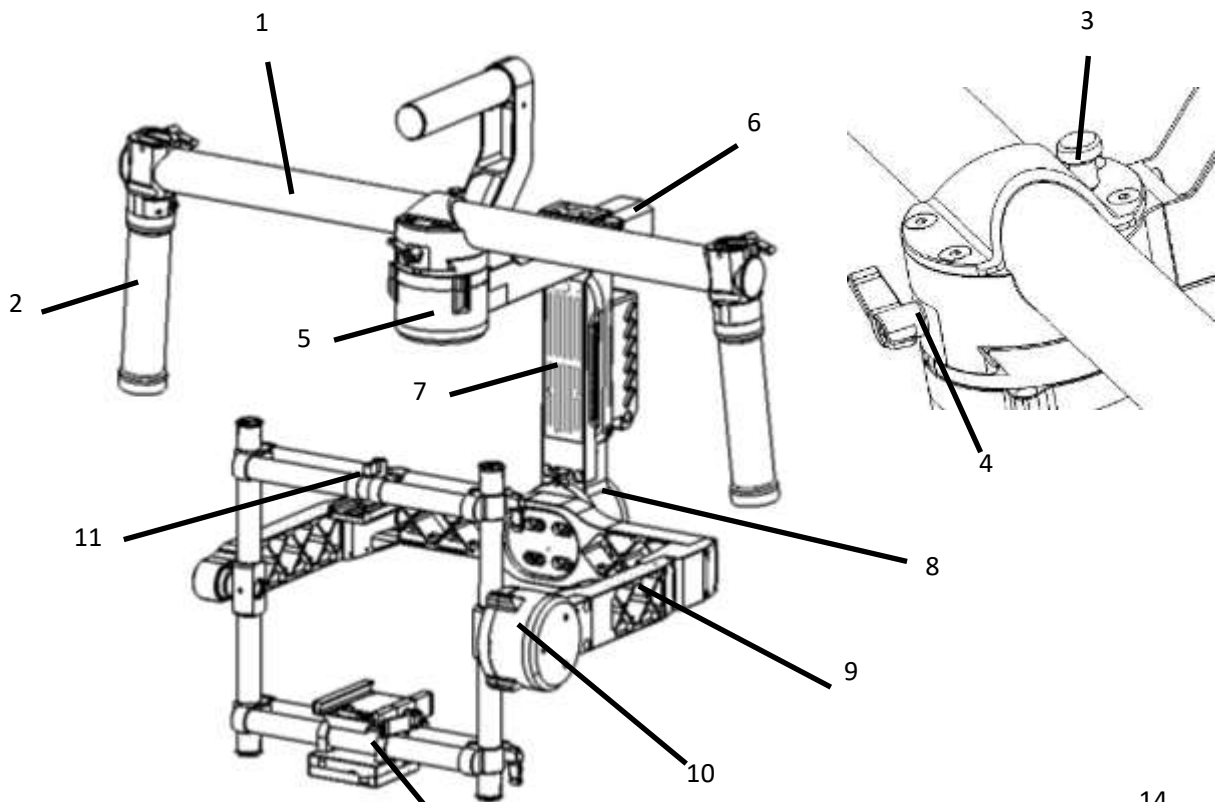

1. Handle bar
2. Slide Handle
3. Safety Pin for Handle Bar
4. Locking-knob for Handle Bar
5. Pan/Yaw Motor
6. Pan/Yaw Arm
7. Mainboard
8. Roll Motor
9. Roll Arm (U-shaped arm)
10. Tilt Motor
11. Camera Upper Mount Assembly
12. Camera Lower Mount Assembly

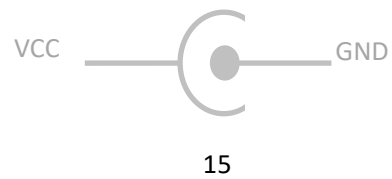
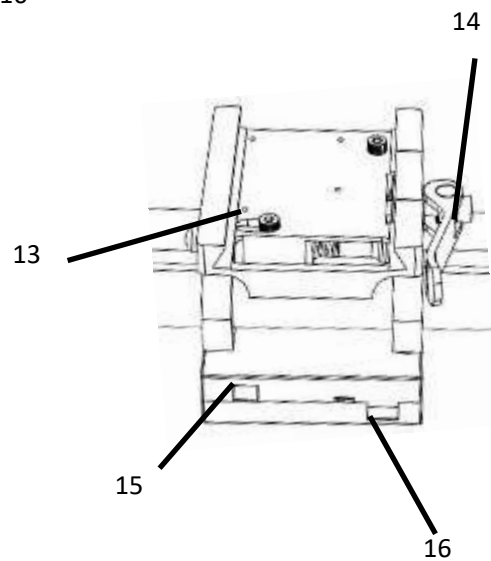

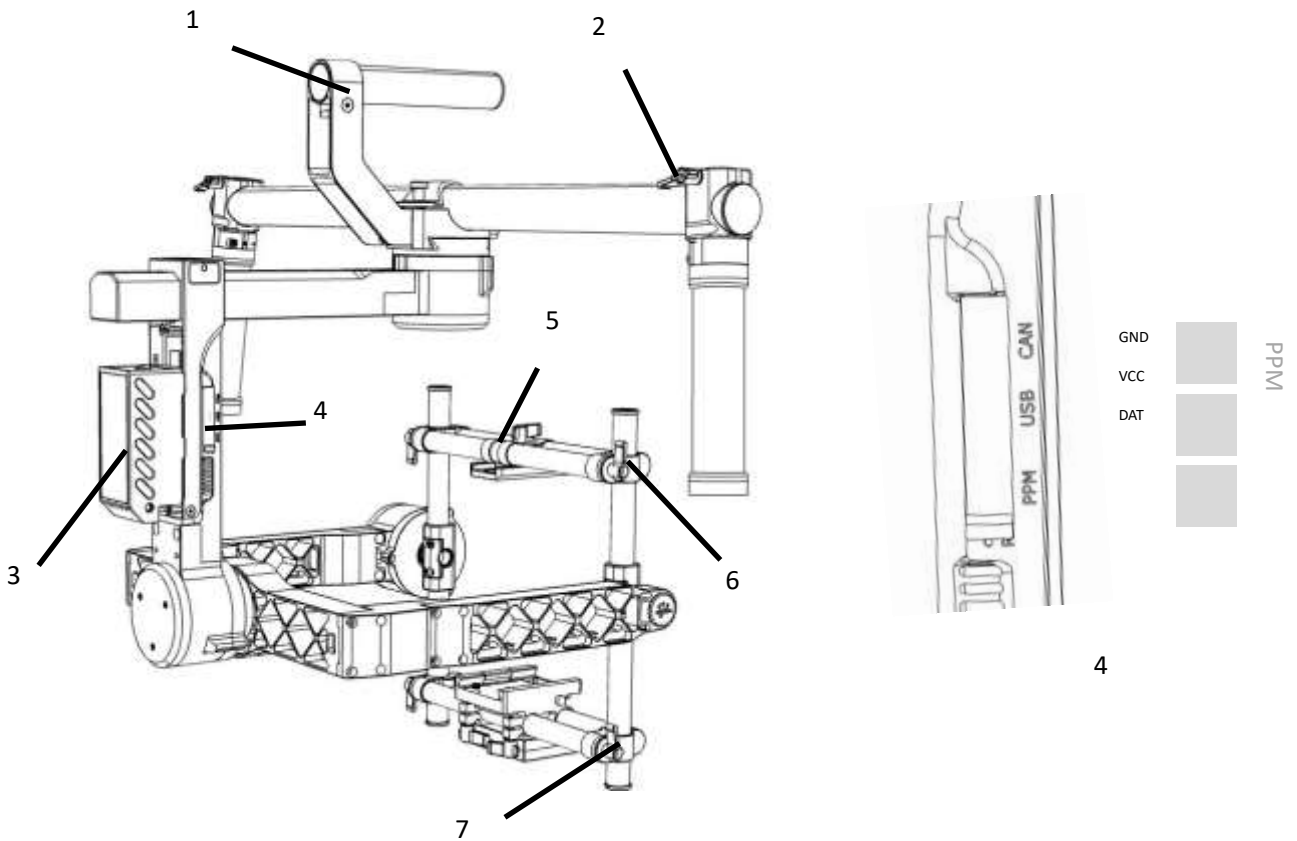

1. Top Handle
2. Locking-knob for Handle Bar
3. Intelligent Battery
4. Communication Port (CAN/USB/PPM)
5. Knob to Lock Camera Upper Mount Assembly
6. Knob to Adjust Tilt Balance of Camera Upper Mount Assembly
7. Knob to Adjust Tilt Balance of Camera Lower Mount Assembly

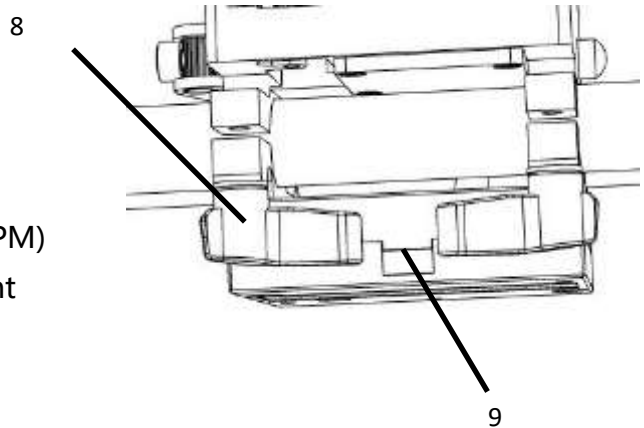

Installation

1. Preparation before installation.

Before you start using your MOZA Pro, be sure to charge the battery. Check the battery level before use.

To check the current battery level, press the button on the left side. Small blue lights will go on.

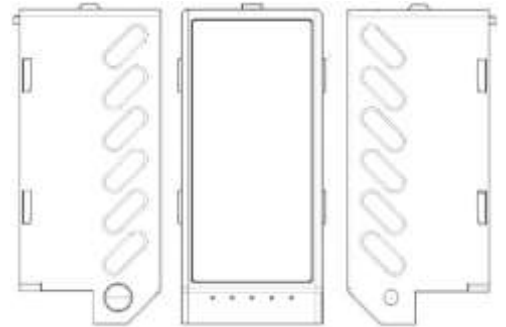

Each blue light indicates 20% power. The battery is charged when the last small light is blinking. The charge port is on the right.

The intelligent battery functions only when installed on the MOZA Pro. It will shut down automatically when it is not installed on the MOZA Pro.

Make sure that the thumb controller is sufficiently charged before attempting to use it. Always check the battery level before use. Press the ON/OFF button for 3 seconds to turn the wireless thumb controller on. The currently battery level will be displayed on the top right side of the screen. Charge the thumb controller with a Micro USB cable when the battery is running low.

The thumb controller can be charged with any standard 5 volt power source with a USB port. Therefore, no extra charger is included here.



When charging the thumb controller in its power-off state, the screen will show "Charging" and indicate the battery level.

2. Install the tuning stand

The stand is composed of an upper rod holder, lower rod holder, and 5 round rods.

The upper rod holder comes with a groove and locking screw on the side.

Insert the two shorter rods without grooves into the lower rod holder to assemble the stand base.

Insert the sleeve-free end of the longer rod into the lower rod holder, and the other end into the upper rod holder.

Insert the two shorter rods with grooves into the upper rod holder and make sure the groove is upwards. This will make it convenient to hold the MOZA Pro.

Tighten all knobs and screws to finish installation of the tuning stand.

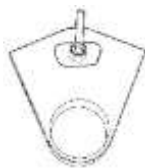

Upper Rod Holder

Lower Rod Holder

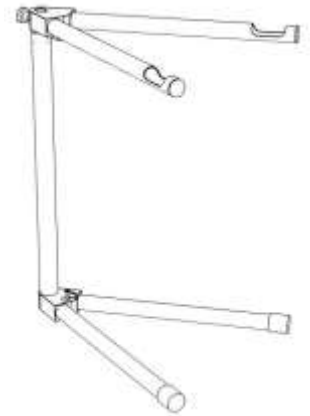
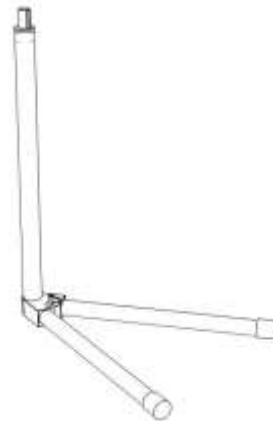

3. Install the handle bar onto the gimbal

Place the handle bar onto the stand. Attach the side handle to the handle bar and lock it in your preferred position. Then, slide it horizontally into the gimbal and tighten the locking-knob. Holding the gimbal by the side handle, make sure the gimbal is not loose.

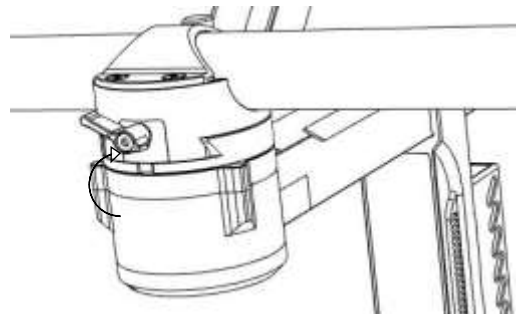
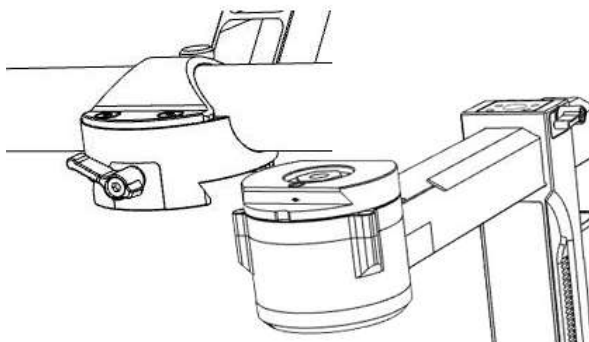

4. Install the intelligent battery

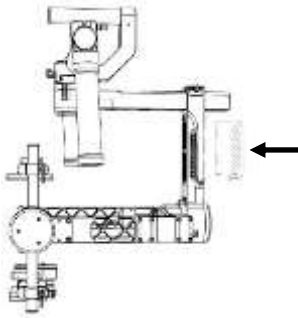

Insert the intelligent battery directly into the battery slot.

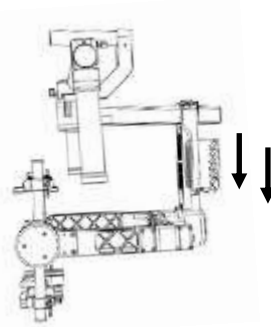

Slide down until the locking-pin is secured.

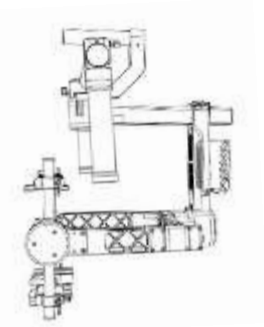

5. Attach the camera to the gimbal

There are two different screws in the mounting plate: $\frac{1}{4}$ " and $\frac{3}{8}$ ". Choose the correct screw holes for your camera's configuration.

Change the horizontal position of the camera on the mounting plate to make sure it is centered.

Slide the mounting plate onto the gimbal. Then, balance the camera on the gimbal and tighten the lock-knob. If the mounting plate does not work properly, use the L3 wrench to tighten the screw below the handle.

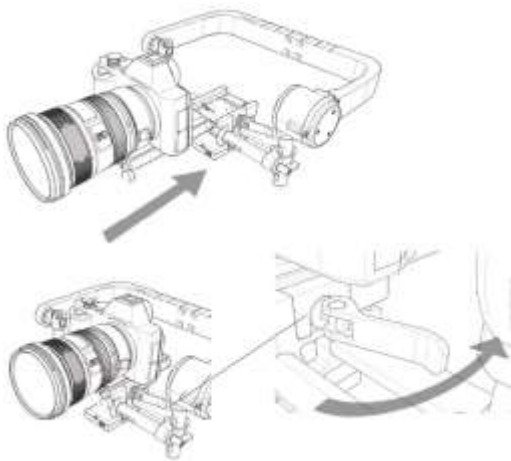

6. Install the extension arms

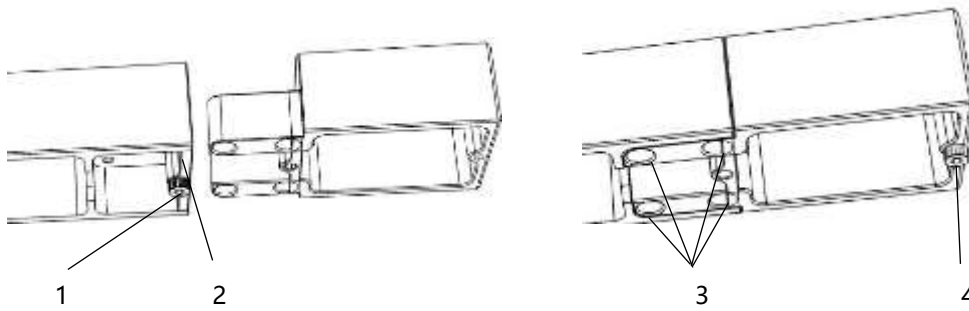

Loosen the screw [1], take out the baffle plate [2], and insert the extension arm into the yaw axis. Secure it with 4 M4*20 screws [3]. Tighten it with 1 M3*10 head screw [4]. You are now finished installing the yaw-axis extension arm.

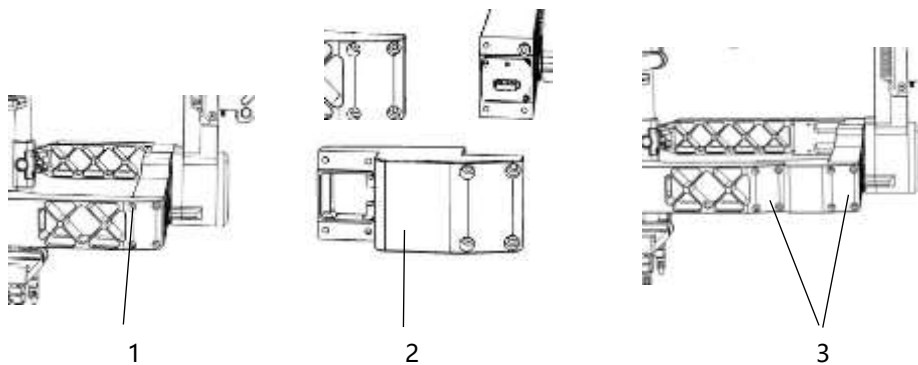

Take out 4 screws at [1], dismantle the rolling arm, and take out the roll-axis extension arm [1]. Fit the roll-axis extension arm to the parting position and use 7 screws to fix the port [3] to finish the installation.

7. Installing the Upper Mounting Kit

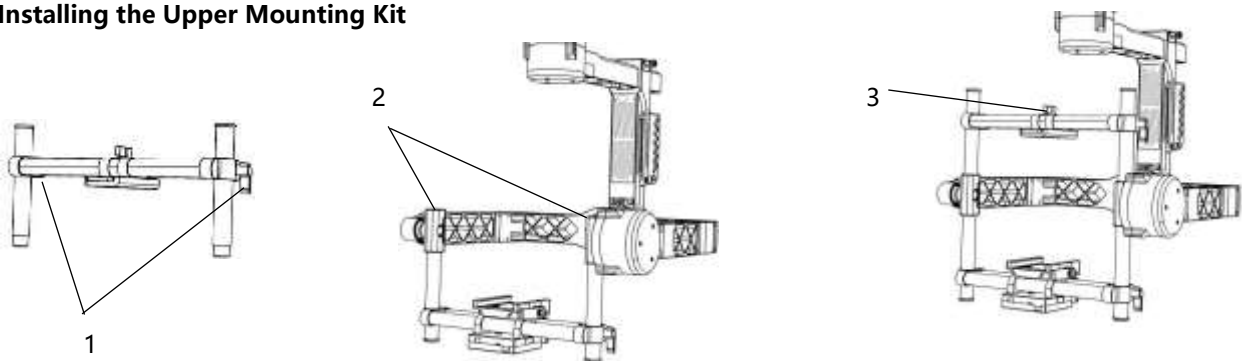

Loosen the tilt arm by loosening the knob at [1]. Insert the upper tilt arm to the connector [2] and tighten the knob.

Loosen the knob at [3], and adjust the locking kit until its screw hole fits into the camera. Then, tighten the camera with either the 1/4" or 3/8" screw.

Installing Counterweights

When the weights of the camera and lens are not distributed evenly, the balance cannot be adjusted. Adding counterweights can adjust the centre of gravity.

The counterweight kit is made up of 3 large counterweights (326g each), 3 small counterweights(155g each) and 1 weight connector.

The weight connector is locked to the specialized quick-release plate via 2 M4*12 cylindrical screws. The counterweights can be installed directly via the 5 1/4'' screw holes under the weight connector. At the bottom of the counterweight, there is also a 1/4'' screw hole. This allows for the counterweights to be connected to one another.

Installation of the counterbalance is generally not required.

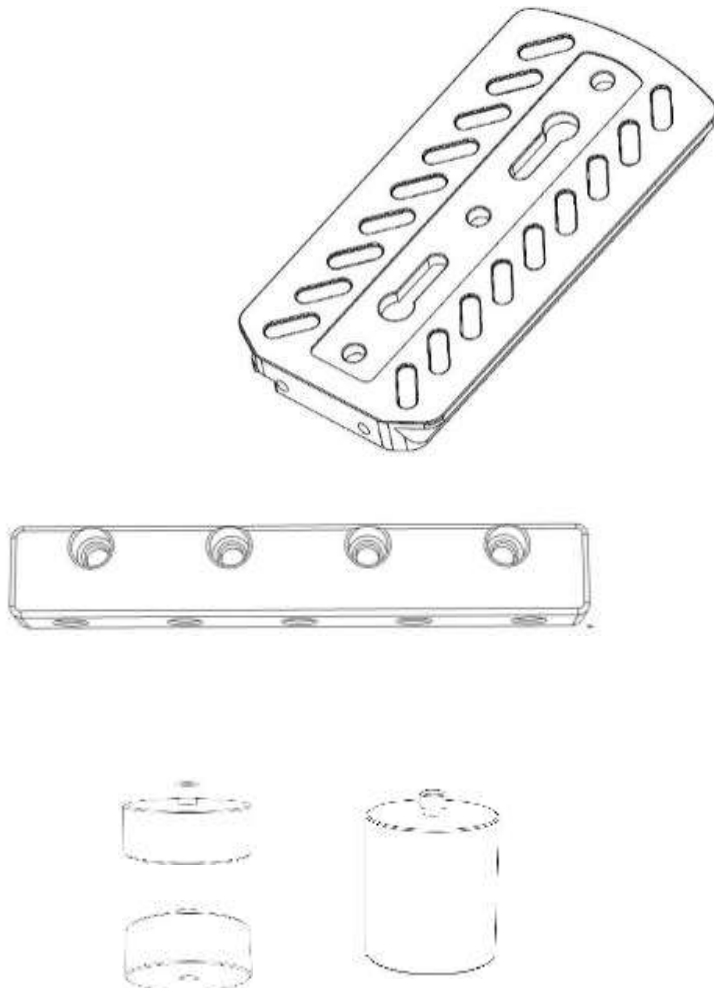

Balance

1. Balancing the tilt axis

Loosen the side clamp to slide the camera forwards or backwards until the tilt axis is level. Then, tighten the side clamp.

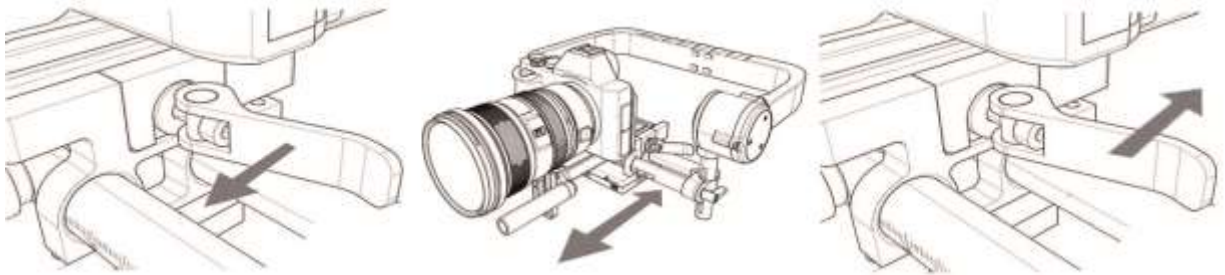

2. Balancing the vertical tilt

Loosen the two lock-knobs to slide the camera upwards or downwards until the camera stays still when released. Then, tighten the two lock-knobs.

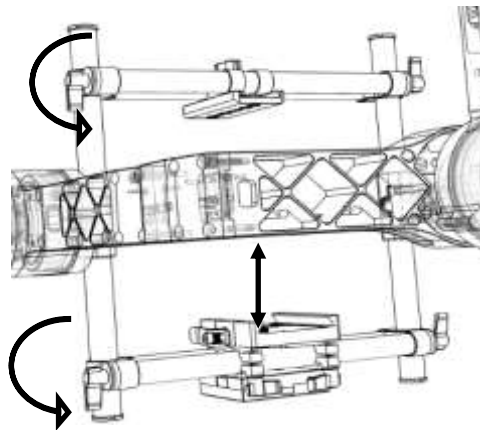

3. Balance the roll arm

Loosen the two lock-knobs to slide the camera left or right until the roll axis becomes level. Then, tighten the two lock-knobs.

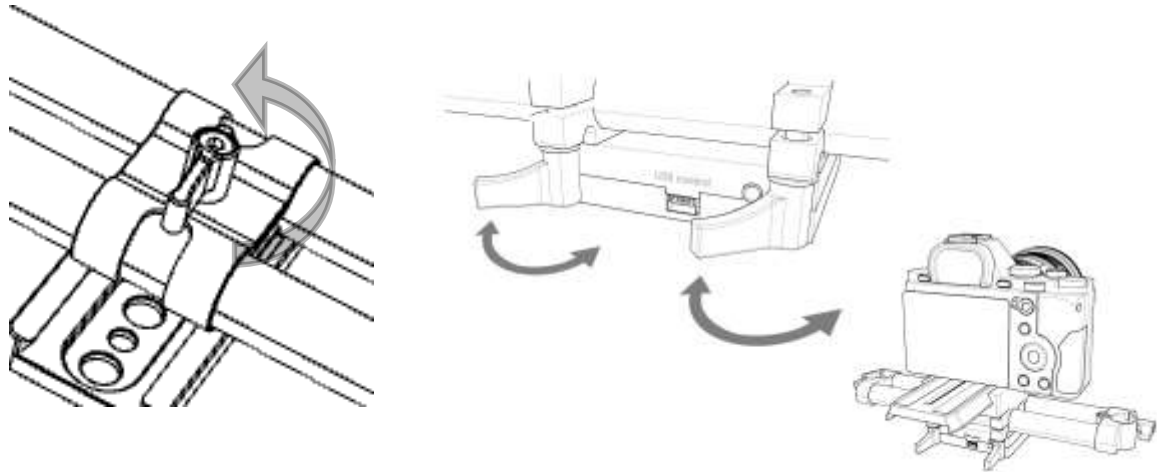

4. Balancing the pan axis

Loosen the lock-knob to slide the compartment forward or backwards until the pan axis stays still when released.

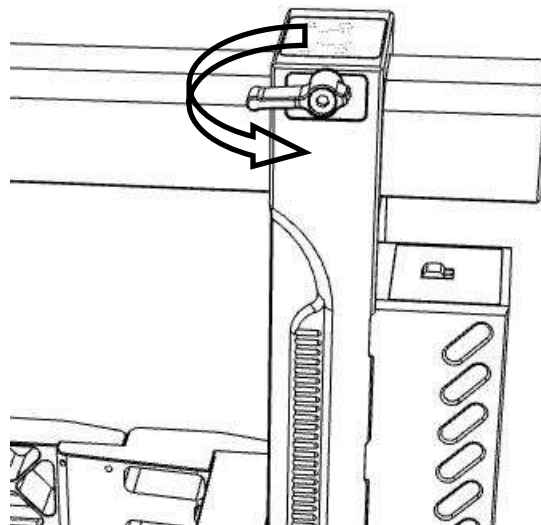

Getting Started

Some things to remember before you get started:

1. Heavy lenses may be necessary in certain cases, but heavy lenses change the camera's center of gravity, causing oscillation. Use the lens support in these situations. Remove the lens support from the tool bag and install it on the pan axis quick release.

2. Follow Focus may also be needed on certain occasions. For your convenience, two tubes for use in installing Follow Focus have been supplied. Remove them from the tool bag and rotate the connecting base of the mount plate.

3. In some situations, you may need to use a very light camera or lens for shooting. Since the roll axis power motor is quite heavy, this may cause the horizontal gravity to be uneven. In such cases, advanced roll adjustment is necessary. Loosen the 4 screws on the U-shaped handle. Contact official customer support, if necessary.

4. After installation and balancing, turn on the battery to make MOZA work. The left button on the battery works as follows:

A quick press in the shutdown state displays the battery level, while a long press in the shutdown state turns on the machine.

A long press when the battery level is displayed forces a reboot, while a quick press in the power-on state causes shutdown.

To check MOZA's function before your first use, follow the steps below:

1. Long press the battery's ON/OFF button to turn on MOZA. This will check if the machine is stable and noiseless.

2. Long press the thumb controller's ON/OFF button to turn on the controller. Check its effectiveness. Move the joystick in all directions to see whether it can operate MOZA successfully and noiselessly.

3. Take the handle from the stand and move it in the roll, pan, and tilt axis directions. Check the camera's stability during this process.

4. Switch to the following different modes: underslung, upright, and briefcase. Repeat step three for each mode.

5. Put the handle back on the stand and turn on the camera. After it is on, quick press the ON-OFF button on the thumb controller to see if the camera will start to record. Roll the roller to observe if it changes the camera's focus. Press the ON/OFF button on the thumb controller while the camera is recording to see if the camera turns off.

6. After completing the steps above, you should be able to begin shooting.

Function Instructions

Follow Mode

Usually, by default a lens will keep level in all circumstances. When the Follow Mode is on, the lens will follow the movement of the operation instead of locking in a level direction.

There are 3 types of Follow Modes. Quickly press the ' Option' button to switch among the modes. For more specific operations, refer to the thumb controller function instructions.

Pan Mode: The default mode. The tilt and roll axes will lock. The lens will keep level and forward, and follow the pan axis movement.

Tilt Mode: Only the roll axis will lock to keep the picture level. The tilt and pan axes will follow the movement.

Pan & Tilt Mode: Only the roll axis will lock to keep the picture level. The tilt and pan axes will follow the movement.

All-Lock Mode: All 3 axes will keep locked. The lens will always stay in a fixed direction.

Operation Modes

There are 3 operation modes for the MOZA Pro. It is very flexible and can change its shape to adapt to various situations. Users can choose the proper mode for their shooting circumstances. The specific steps for transformation are as follows:

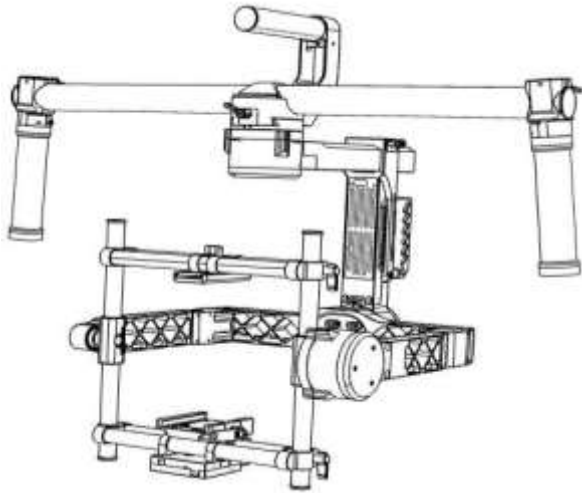

Underslung Mode

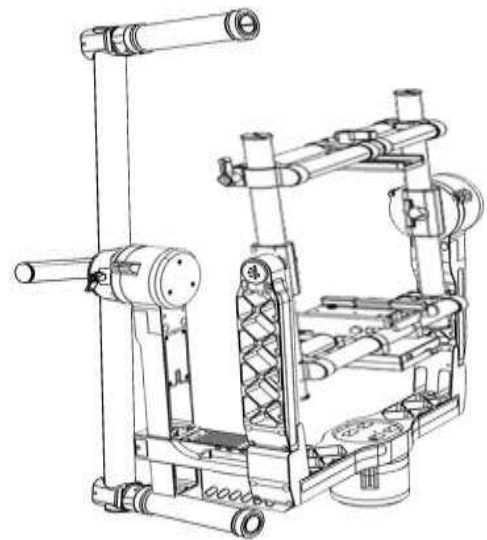

Briefcase Mode

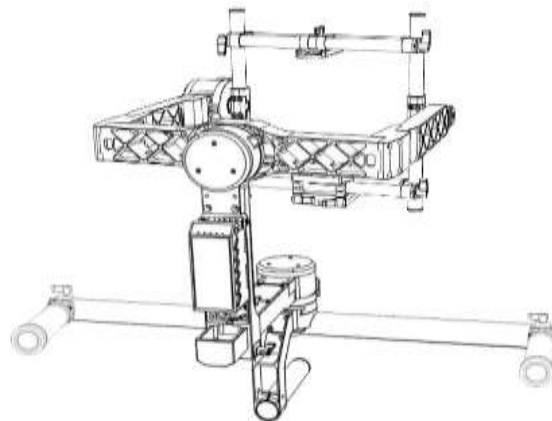

Upright Mode

Gimbal Movement Control

The gimbal's movement can be controlled by the thumb or SBUS controller. The thumb controller works effectively within 30 meters of the gimbal. It can control the pan and tilt axis movements in all Follow and Operation Modes. The gimbal will stop and hold the last position. The last position will then become the new stable position, and MOZA will balance according to it. The control effect won't be interrupted by your movement or a Follow effect. You can control the gimbal's movement by the thumb controller or through your own actions.

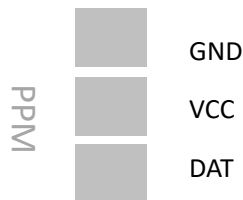

Opposite cable connections may lead to an inability to control the gimbal with the wireless thumb controller. Errors in VCC will cause electrical circuit fault. Please make sure the correct cables are connected before the power is turned on.

Wireless Thumb Controller

Interface Diagram

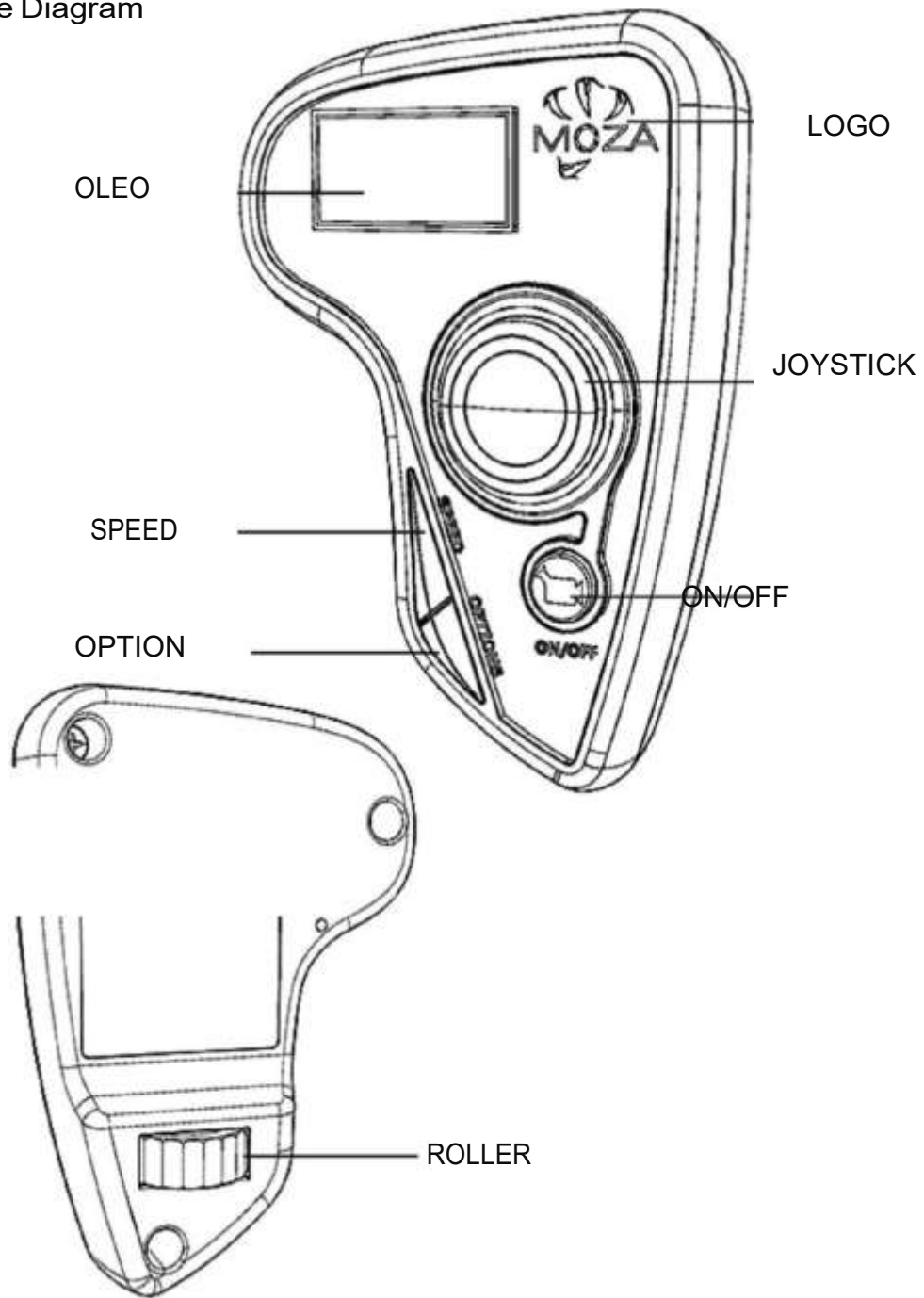

Button Introductions

JOYSTICK

The main interface controls the up, down, and sideways movements.

On the menu interface, vertical movements will select projects. Moving leftwards will return you to the previous menu. Moving rightwards confirms your selection.

On the Data Input interface, vertical movements increase or decrease the number, and move you to the left exit. Moving to the right will preserve your MOZA selections and make them effective.

SPEED button

A single press will change speeds between Low/Medium/High.

A long press will change the speed settings between the gimbal movement and focus control speeds.

After connecting with the USB, pressing the SPEED button will cause the device to enter the firmware upgrade mode.

OPTIONS button

A single press will switch the Follow Mode between pan follow, tilt follow, and all locked.

A long press will bring you to the main menu.

After connecting with the USB, pressing the OPTIONS button will cause the device to enter the factory mode.

ON-OFF button

A single press will start or stop recording. A long press will turn the power on or off.

ROLLER

Rolling horizontally controls the camera focus. Double click to return to the initial status.

Using the Main Menu

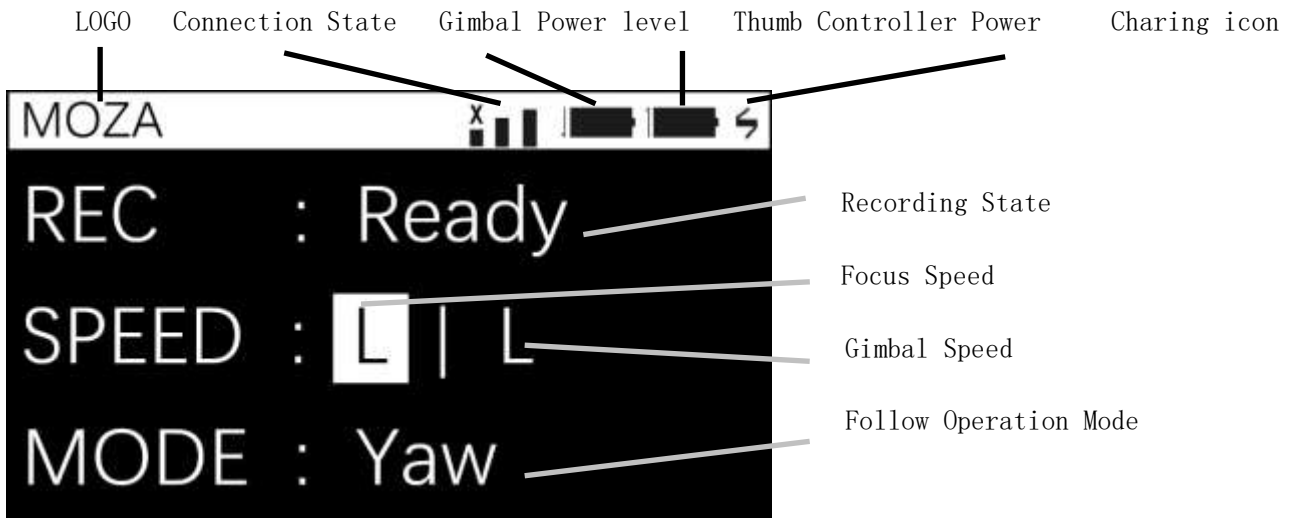

REC:

Ready	Ready to record
Recording	Recording

SPEED Status:

Focus Adjustment Speed	Remote Control Speed
L Low	L Low
M Medium	M Medium
H High	H High

FOLLOW MODE:

Yaw	Yaw axis follow, tilt axis locked
Pit	Yaw axis locked, tilt axis follow
Pit-Yaw	Pan axis and tilt axis follow
All Lock	All-lock

1. Starting or stopping the recording

A single press of the ON/OFF button.

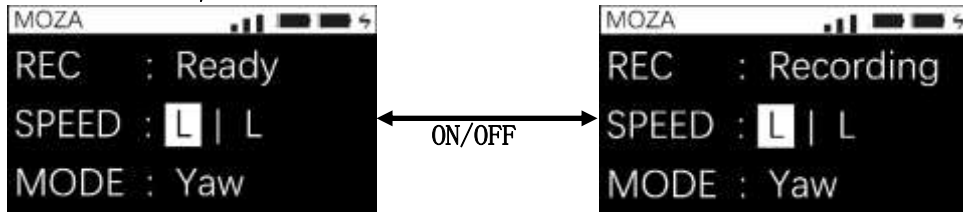

2. Adjusting the focus and gimbal movement speeds

A single press will change speeds between Low/Medium/High.

A long press will change the speed settings between the gimbal movement and focus control.

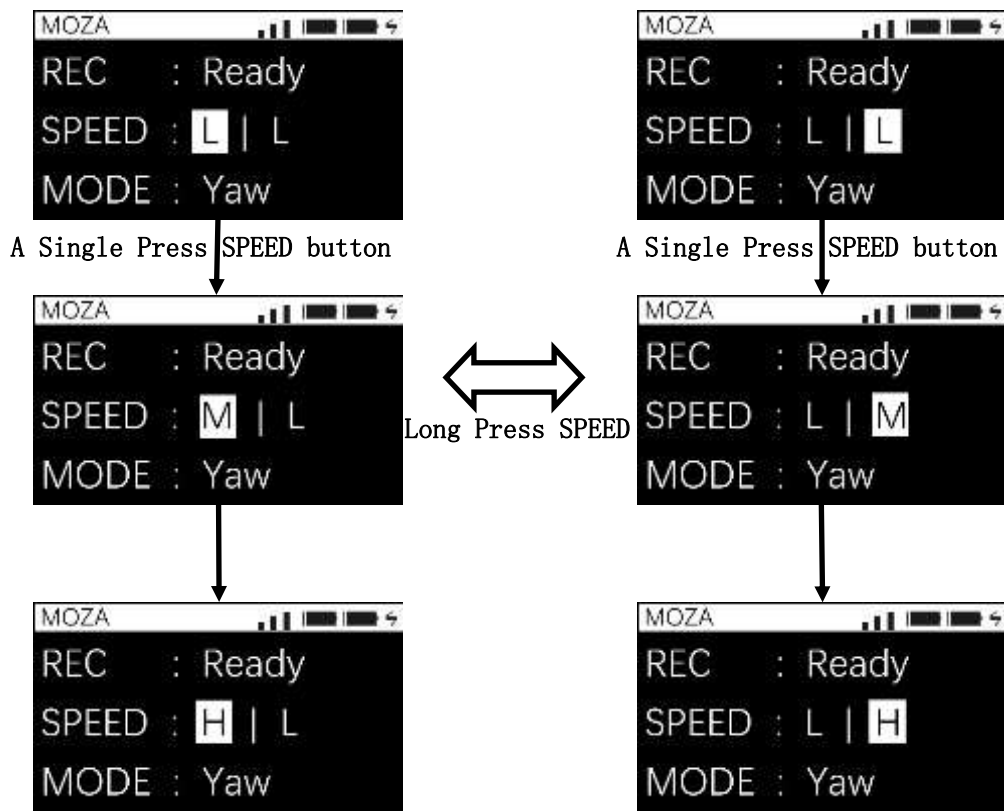

3. Switching the Follow Modes

A single press will switch the Follow Modes between pan follow, tilt follow, and all locked.

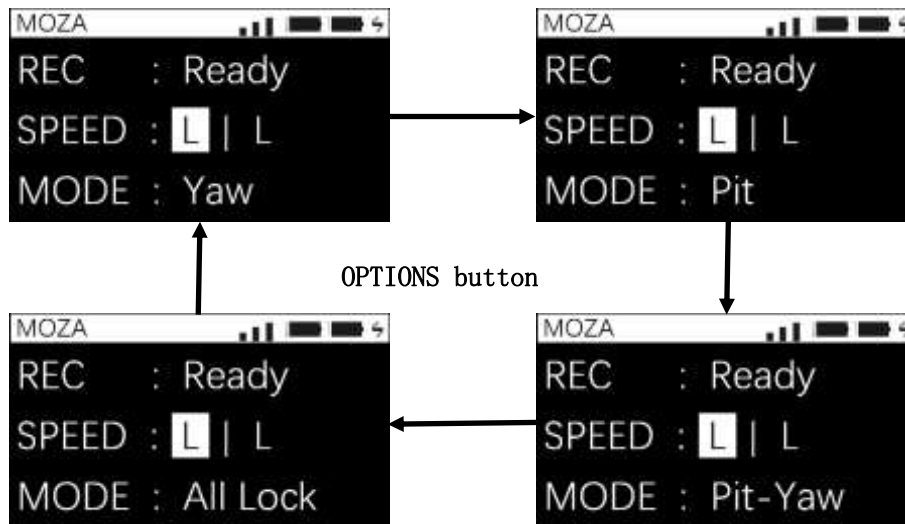

4. Adjusting the camera focus

Roll the roller.

5. Adjusting the camera focus

Entering the Main Menu interface, long press the 'OPTIONS' button.

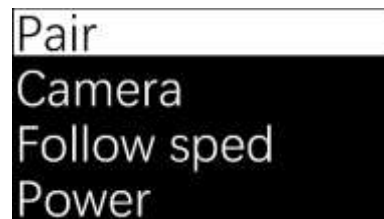
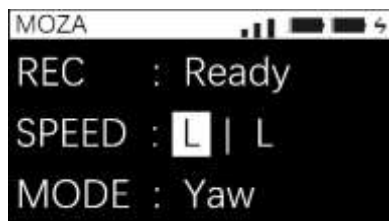

6. Turn Off

Long press on ON/OFF button.

Thumb Controller MenuContent

Top menu	Secondary	Third	Fourth
Pair	NO		
	YES		
Camera	EOSDSLR	Lens ultralight	
		Lens light	
		Lens heavy	
	EOSCinema	Lens ultralight	
		Lens light	
		Lens heavy	
	Alpha	Ditto	
	GH	Ditto	
	BMCC	Ditto	
	BMPC	Ditto	
BMPCC	Ditto		
Habits	Joystick	Mode	4 Directions
			8 Directions
		Up Down	PIT
			ROLL
			YAW
		Left Right	PIT
	ROLL		
	YAW		
	Reverse	LEFT-RIGHT	
		UP-DOWN	
	Display	Custom	(min)
		Always On	

Pairing

It is necessary to pair the MOZA with the thumb controller when you change the thumb controller or MOZA gimbal. Long press OPTIONS to enter the menu. Then choose 'Pair' and move the joystick rightwards to enter the secondary menu. Move the joystick downwards to choose the YES option, and move the joystick rightwards again to enter the 'Pairing' mode. Wait for MOZA to turn on pairing. The interface will appear, as below. Install the intelligent battery in MOZA, and the pairing is complete.



Every MOZA gimbal is properly paired before shipping. There is no need to pair again. Pairing failures may happen when the thumb controller firmware does not match the gimbal firmware. You have to upgrade both the wireless thumb controller and gimbal firmware to the latest version.

Choosing Camera Types

Because there are different weights and means of control, MOZA needs different parameters to balance itself. After choosing a type of camera, the corresponding parameters must be saved to MOZA. You must keep the power on while operating.



Follow Speed

Adjust the motor rotation speed in Follow Modes. There are three options, L/M/H, to adjust the speed. The higher the speed is, the faster the gimbal responds, and the shorter the follow time is.



The specific figures of the different levels can be subtly adjusted with the MOZA Assistant software. After the adjustment, the thumb controller will display 'Set OK'. Otherwise it will display 'Set ERR'. In this case, it must be reset.

Adjusting the motor' s output power

When the loaded camera is light and the torque is high, the gimbal may jerk and make noise. On the contrary, when the loaded camera is heavy and the torque is low, the gimbal cannot keep stable and the wireless thumb controller fails to control the gimbal' s movement.

In such cases, enter the main menu and click 'Power' .

The three-motor torque can be adjusted separately. Choose the motor that needs adjustment, and move the joystick up or down to resize the data. Turn the joystick rightwards to save.



If the screen reads "Set OK", it means you were successful. "Set ERR" means the save was unsuccessful.

Calibrating the Sensor

Sensor calibration is necessary if each axis of the gimbal starts to drift when the MOZA Pro turns on.

Enter the menu, choose Motor, and click OFF. The motor will stop working and the wireless thumb controller will show 'Set OK' . Choose ON when you need the motor to work.

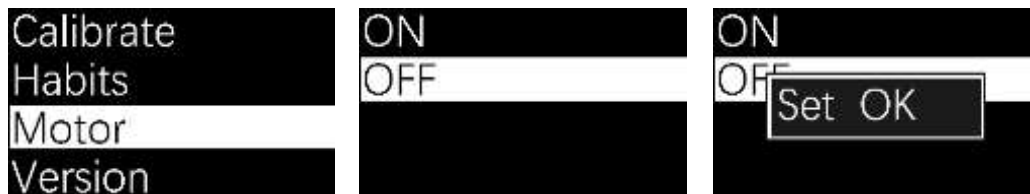

Place the MOZA Pro on a sturdy and stationary surface. Turn on the wireless thumb controller and enter the main menu. Click 'Calibrate.' Then choose YES. The wireless thumb controller screen will display 'Calibrating' . The gimbal should remain stable during the calibration process. Restart the MOZA Pro once the thumb controller shows 'Calibration OK' to finish the calibration.



Preference

The preference setting can customize parameters and the backlighting time of the screen.

Click "Joystick" to enter the setting menu. Click "Mode" to set the operation mode. Either 4 (up, down, right, left) or 8 directions are possible. When done, the screen will display "Set OK".



'Up Down' is used to remap the joystick up-down control of the gimbal movement and 'Left Right' is for right-left control. Choose the axis that needs to be remapped and move the joystick rightwards. Once the thumb controller shows "Set OK", return to the main interface. After completing the remapping, move the joystick and the corresponding power motor will follow.



'Reverse' will make the power motor move the opposite way of the joystick. You can adjust according to your own needs. Operation direction has no relationship to the joystick map or the 4/8 Direction mode.



'Display' will set the OLEO background light. To choose 'Backlight', move the joystick rightwards and enter the fourth menu. There are 2 options: 'Custom' and 'Always on'. When you want to choose 'Custom', move the joystick rightwards to set the brightness time. The default time is 1 minute.



Version

Check the wireless thumb controller's hardware and firmware version.

Click on 'Version' and move the joystick rightwards to view the version.



The front data is the hardware's version and the back data is the firmware version.

Software and APP

Supported Systems:

Application	Operating System	Version
MOZA Assistant	Windows	Windows XP/Windows 7/Windows 8/Windows 10
MOZA Assistant	Mac	Mac OS X 10.0 above
MOZA Assistant	iOS	iOS 5 above
MOZA Assistant	Android	Android 4.0 above

It is necessary to manually install the Virtual Serial Port Driver the first time you connect the MOZA Pro to a windows computer. There are a few devices that cannot install the drive, due to compatibility issues.

For Mac users, it is necessary to set "Allow software to run" in the preference setting.

It is necessary to connect to the internet to download the firmware files. Make sure your network is working properly.

Connecting the MOZA Assistant to the MOZA Pro

There are three different interfaces in the MOZA Assistant software. Each represents a different status of the MOZA Pro and thumb controller.

I、Adjust Parameters (after MOZA Pro is balanced):

1. Install the intelligent battery and turn on the gimbal
2. Connect the USB cable
3. Open the MOZA Assistant software

II、Upgrade Gimbal Firmware:

1. Open the MOZA Assistant software
2. Connect the USB cable
3. Install the intelligent battery and turn on the gimbal

III、Upgrade Thumb Controller Firmware:

1. Open the MOZA Assistant software
2. Turn off the thumb controller
3. Long press **SPEED** and connect the USB cable

The operating sequence above should be strictly followed. Different operating sequences will lead the software to different interfaces. If you enter the wrong interface, please close the MOZA Assistant software, unplug the cable, and turn off the device.

Only one window of the MOZA Assistant software can be open at a time. The software cannot recognize the device when multiple software windows are open.

Use Software to Adjust Parameters

Follow the steps below to enter the parameter adjustment mode.



Turn off motor: Tick this box to shut down the motor's power. It's required to check this box before calibrating the sensor. Otherwise, data errors in the calibration may occur. Adjust the motor's working state and not make any noise. Check this box when audio is required.

Sensor Calibration: Calibrate the gyroscope sensor.

Power: The output value of each motor. When the loaded camera is relatively light but the torque is high, the gimbal may shake or generates noise. When the loaded camera is relatively heavy but torque is low, the gimbal may fail to remain balanced or the thumb controller may fail to properly control the gimbal movement. Lower the motor power to eliminate serious shakes after the gimbal is turned on.

Rotation range: Use the software to control the maximum rotation angle. This is not recommended for regular use.

Follow: Adjust the parameters in each Follow Mode.

	Accel	Dead Angle	Smoothing
<input checked="" type="checkbox"/> Pit	2.000	10.000	0.080
<input checked="" type="checkbox"/> Yaw	2.000	13.000	0.080

Check to start Follow Mode.

Accel: Adjusts the accelerated speed from still to rotate.

Dead Corner: Deviation angle allowed before a Follow movement.

Smoothing: The smoothing of each axis when the outer remote operates the gimbal.

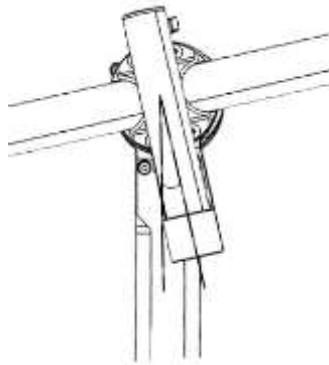

Camera Lens: Choose the proper type of camera and lens.

Camera Lens	
Camera	<input type="text" value="EOS DSLR"/>
Lens	<input type="text" value="Ultra Light"/>
Default Profile :	
<input type="text" value="0%"/>	<input type="button" value="Start"/>

Mechanical Angle: Each motor's rotation angles from its initial position.

Monitor: real-time view of the video captured by the camera.

The mechanical angle is the actual rotation angle of the motor. The monitor angle is the angle calculated by the gyro-sensor, which is the deviation angle of the camera along three axes.

The mechanical and monitor angles should remain constant under static conditions. The gyroscope data should fluctuate around ± 0.03 .

Machine Angle	
Pit	-168.3
Rol	-25.8
Yaw	-143.9

	Angle	Gyro	Power
Pit	168.16	-0.12	-21
Rol	-22.85	0.13	-33
Yaw	-142.22	0.07	50

Motor Pit

Motor Rol

Motor Yaw

Gyro Pit

Gyro Rol

Gyro Yaw



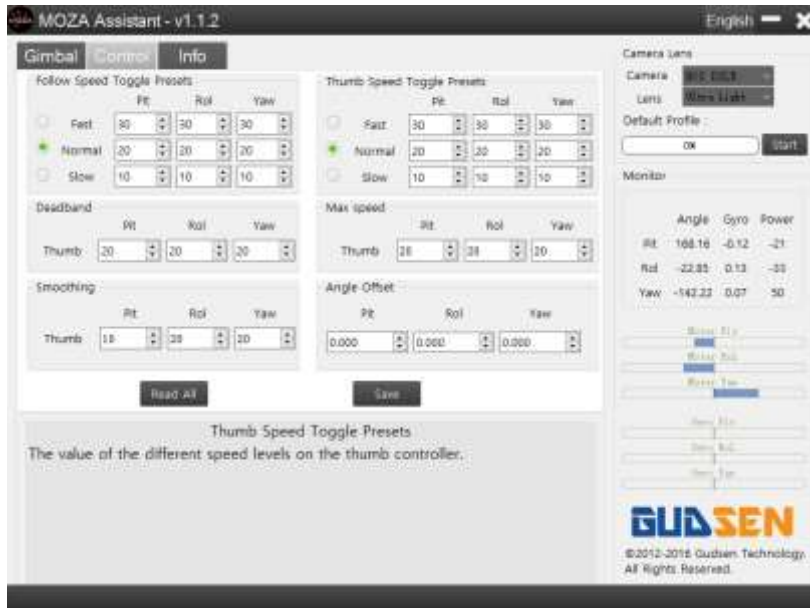

Follow Speed: The specific values of the different speed levels of the gimbal's follow movement. There are three options of follow speed: Low/Middle/High



Remote Speed: The specific values of the thumb controller operating the gimbal. There are three options for the thumb controller: Low/Middle/High.



Dead Range: The gimbal will not rotate when moving the joystick of the thumb controller in the dead range.

Max Speed: The max speed of the thumb controller controls the gimbal's movements.

Smoothness: The flexibility of the motor's actions when the thumb controller controls the gimbal's movement.

Angle Offset: When there is a slight deviation between the locked and absolute positions, the angle offset can be used to offset the deviation.

Angle Offset

Pit	Rol	Yaw
0.000	0.000	0.000

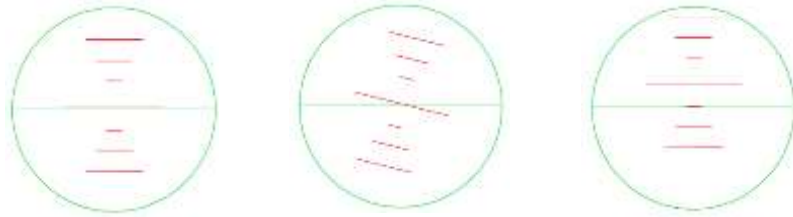

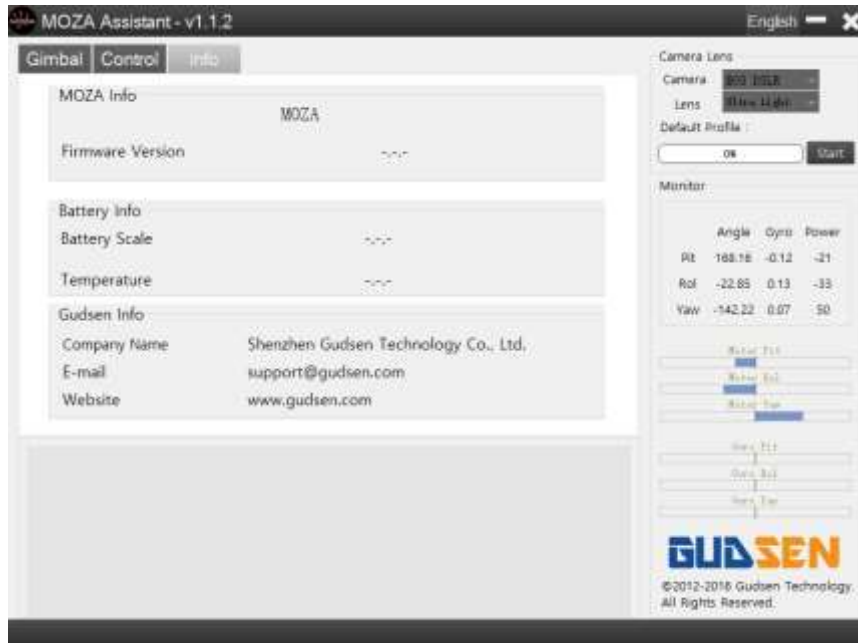

Whether the MOZA Pro enters the parameter-adjustment or firmware-upgrade mode is decided by if you first open the software or turn on the battery. A few computers may fail to enter the firmware-upgrade state. Setting the upgrade wait time will help avoid such errors. This parameter does not need to be modified.

Calibrating the Sensor

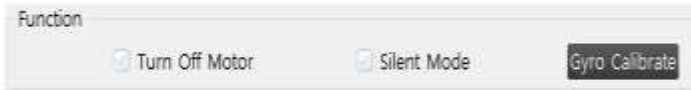

Before calibration, turn off the motor and uncheck the Follow Mode. Place the gimbal on a sturdy and stationary surface. Click “Sensor Calibrate” to begin calibration. Wait for at least three minutes, and then check for any changes in the gyroscope’s data. The calibration is complete when all of the gyroscope’s axis data fluctuates within 0.05. Otherwise, attempt an additional calibration.

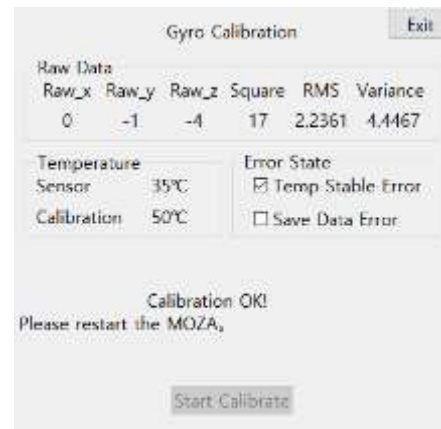
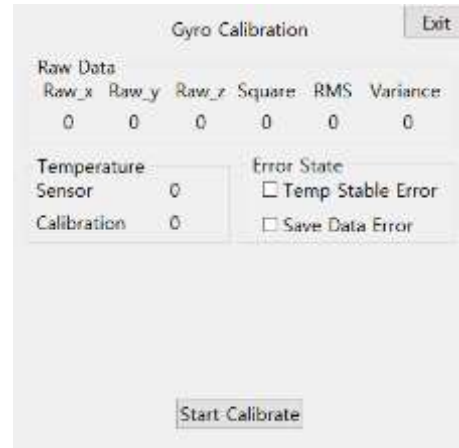

Upgrade the MOZA Pro Firmware

Follow the steps below to upgrade the MOZA Pro firmware.

1. Open the MOZA Assistant software
2. Connect the USB Cable
3. Install the intelligent battery and turn it on

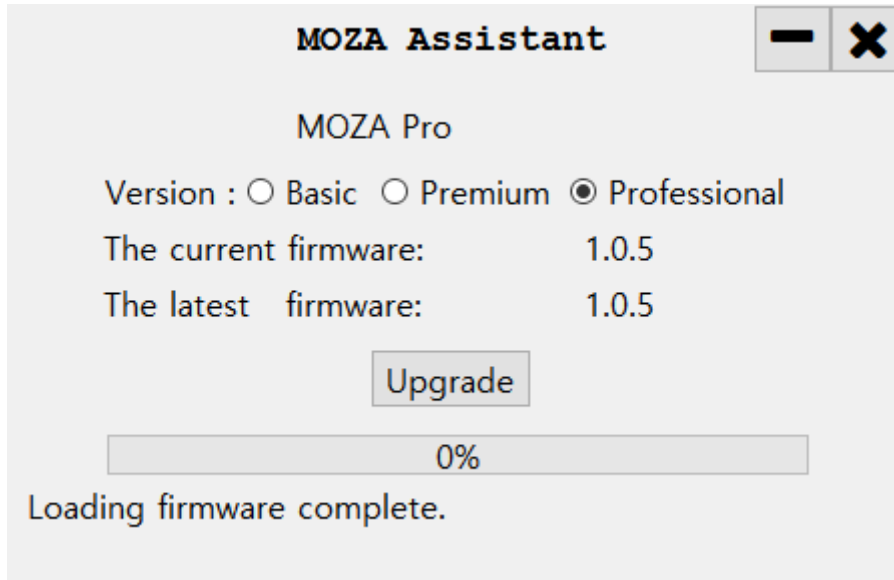

First, connect the gimbal to a PC or Mac through the USB cable. Then, turn on the MOZA Pro. It will enter the firmware upgrade mode. Choose the correct version and click the upgrade button. The MOZA Assistant will then download the firmware from the server and automatically upgrade.

Upgrade the Wireless Thumb Controller Firmware

Follow the steps below to upgrade the thumb controller firmware.

1. Open the MOZA Assistant software
2. Turn off the wireless thumb controller
3. Long press on SPEED and connect the USB cable

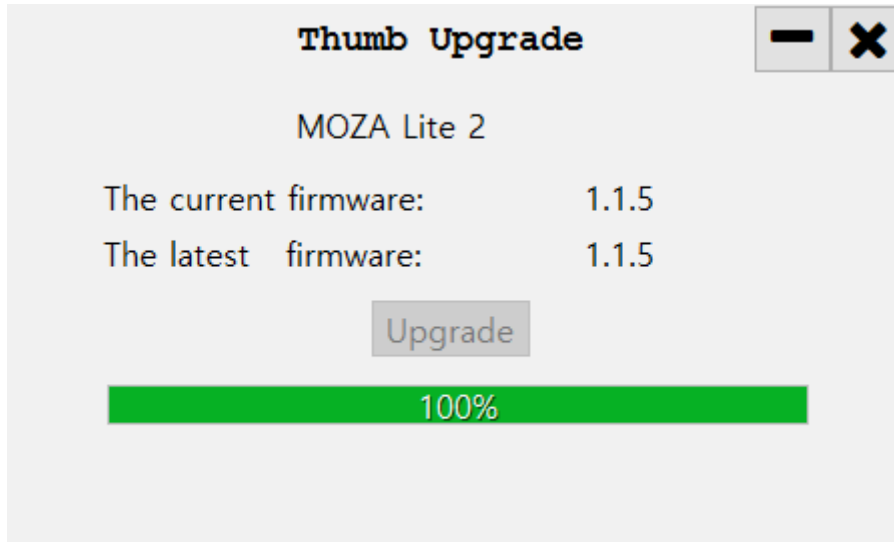

The MOZA Assistant software will automatically access information from the wireless thumb controller and download the latest firmware you're your network connection. Click the 'Upgrade' button after the downloading is finished.

Specifications

MOZA PRO

GENERAL

Weight	3.6kg
Dimensions	50*25*35(CM)
Max Payload	10.0kg

Extended Interface

Bluetooth	BLUETOOTH 4.0
Wireless Remote Control	2.4G
USB Input	Micro USB
PPM	General PPM Protocol
CAN	General CAN Protocol
USB Control Output	Mini USB
USB Power Output	Mini USB 5V 1A
DC OUT	3.5MM 14.8V 0.8A

Electrical Parameters

Working Voltage	14.8V
Resting Current	20mA
Static Current	300mA
Dynamic Current	4A
Bluetooth Control Range	5M
2.4G Remote Control Range	50M

Mechanical Performance

Supported Device Dimensions:	18*15*25(CM)
Max Rotation Range:	
Tilt:	360°
Roll: Left: 75° Right:	235°
Yaw:	360°

Wireless Thumb Controller

Weight	100g
Battery Capacity	600mAh
Battery Voltage	3.7V
Working Current	50mA
Resting Current	10mA
Battery Life	4h
Wireless Type	2.4G
RC Range	50M
Charging Voltage	5V
Charging Time	2h

Intelligent Battery

Capacity	2800mAh
Output Voltage	14.8V
Output Cut-Off Voltage	12V
Output Current	12A
Output Cut-Off Current	100mA

Charger

Input Voltage	110~220V AC
Output Voltage	16.8V
Output Current	2A

FAQs

FAQs

1. Gimbal skew

If the initial gimbal gesture skews, open the MOZA Assistant on your PC to correct the gesture and calibrate the sensor.

2. Low power motor output

First, balance the gimbal. After eliminating the possibility of overload caused by bad balancing, choose the proper lens weight via the thumb controller. If the problem isn't solved, open the MOZA Assistant on your PC to turn up the corresponding value.

3. Follow speed is too slow

Turn on the thumb controller. Open the Parameters App and MOZA Assistant to adjust the speed of each axis.

4. Thumb controller cannot be used to record.

First, check all of the cables to make sure they are correctly and properly connected. Then, turn on the thumb controller and choose the proper type of camera. The types of cameras are listed on Page 16 of this manual.

5. Gimbal movement is beyond the control of the thumb controller

First, check the icons on the screen of the thumb controller to make sure there is a connection. If not, pair them again. After ensuring that they are properly connected, check the joystick map function.

6. If there are vibrations after the MOZA Pro has been calibrated, check all of the knobs and screws to make sure they are well tightened, if they aren't, use the screwdriver to tighten them up.

7. In the case of a power motor shutdown, it is likely that the three axes of the MOZA Pro have engaged the self-protection function. When there are abnormal conditions, the self-protection mode shuts off the power.

Maintenance

This product uses double-decker packing. The outer container is designed to bear any logistic transportation damage. The inner container is a paper box (for basic and premium devices) or flight case (for professional devices) for use in safekeeping of the product during storage.

In the case of long term lack of use, please remove the battery and store the MOZA Lite 2 and accessories in the inner box. The product should be stored in a dry and cool place, away from direct sunlight, damp conditions, and water.

Accessories should be stored in the tool bag to prevent scratches and loss.

Current increases rapidly when the power motor is started. Therefore, detach the electrical machine to extend its life.

The stand should be used for MOZA Pro storage. Do not hang other heavy items on the stand. Without the stand, the L-shaped handle bar can be detached and the MOZA Lite 2 can be stored on a table in the underslung mode.

Please retain this user manual.

Website: www.gudsen.com

Customer Service: support@gudsen.com



GUDSEN
www.gudsen.com
