



KINEFINITY INC.

MAVO LF

OPERATION MANUAL

For KineOS 6.2

MAVO LF BRIEF INTRODUCTION

Kinefinity Inc. has been developing the cameras covering optical design to FPGA, circuits and software, with assistance from filmmakers, broadcasting industry and academic schools.

The large format MAVO LF and MAVO S35 cameras are considered to be the flagship 6K cameras by Kinefinity. MAVO LF, is the full frame camera of Kinefinity, 6K records up to 75fps and 4K wide up to 100fps, can either shoot ProRes or RAW.

- Full frame 3:2 6K CMOS sensor;
- Dual native ISO: 5120/800, low noise level and high latitude image at both settings;
- ProRes: in-camera ProRes recording at any fps, in-camera oversampling 6K to 4K/3K;
- Compressed RAW cDNG: The compression ration of cDNG can be set to 3:1, 5:1, or 7:1, which is supported by Davichi Reslove for editing or grading;
- Compressed RAW KRW 2.0: will be enabled in firmware in the first half year of 2019;
- High frame rate: up to 200fps@2K Wide; up to 150fps@3K Wide; up to 100fps@ 4K Wide;
- Low rolling effect: fast sensor readout speed, barely suffer any rolling shutter effect ;
- 14+ stops with KineLOG3: Preserve highlight and shadow perfectly, provide max room for post;
- Custom LUT: Support third-party 3D LUT from shooting to post;
- 2.5-inch 7mm professional KineMAG SSD as Record Media, compatible with consumer-type SSD;
- KineMount (Interchangeable mounting system) supports PL/EF/Sony E Mount and even EF/PL Mount with e-ND;
- Multiple monitoring output: Video port x2, HD output x1 and 3G SDI output X2 through KineBACK-W.

MAVO LF follows the very compact and modular body of TERRA/MAVO and shares most of the accessories with the two cameras, suitable for both one-man job and film crew. ProRes codec enables fluent post workflow. With professional ports, MAVO LF is a powerful cinema camera that offers amazing footages while supporting an effective post workflow.

SAFETY TIPS

Please read all contents of the manual carefully:

- Pay attention to the **CAUTION** and **NOTE**;
- Do not use the camera near water in case of water droplets that can splash on the camera body;
- Do not ject the camera to severe vibrations;
- Do not use camera under direct sunlight; operating temperature should be from 0 °C to 40°C ;
- Do not use the camera near strong magnetic field, pretty dust, high humidity or lighting storm places;
- Avoid condensation during transportation or transitions;
- Do not block the vent, or it will cause overheating that will damage the camera;
- Do not expose the LCD/OLED screen to harsh direct sunlight, and do not squeeze or hit the monitor in case of any damage to the screen;
- Only use accessories recommended by Kinefinity.

While using the camera, please:

- Turn off the camera when you try to attach or detach a Lens Mount, KineBACK-W or HDMI monitor;
- Avoid to touch the OLPF when attaching or detaching an adapter, as the optical element is fragile. MAVO LF is with changeable OLPF, please be careful when you change it;
- The EF mounting adapter is a lock-type (cine-type) EF mount. When mounting a lens to the camera, the position of red dot in the mount is DIFFERENT from a DSLR camera. Secondly, it is a LOCKING RING rotation, NOT a lens rotation. Make sure the EF lens is aligned pogo-pin contact inside of EF mount, now you can firmly lock the lens in place by rotating the locking ring on the lens mount (the arrow on the mount suggests which direction);
- Hold the lens while detaching it from the lens mount, to prevent from accident.
- We strongly recommend inserting or removing the SSD only after camera is powered down. If you like to hotswap, you must Deactivate the SSD at first (SSD section in UI shows **SSD: Ins**), and then open the push-pull locking lever to get the SSD out.

CONTENTS

MAVO LF BRIEF INTRODUCTION	2
SAFETY TIPS	3
1. OVERVIEW	6
1.1 Interfaces and Buttons	6
1.2 Functions of Buttons	8
1.3 Interface and Parameters	9
1.4 Default Settings	10
2. QUICK GUIDE	11
2.1 Power Supply	11
2.2 Mount	12
2.3 Lens	13
2.4 Monitoring	14
2.5 SSD Mag	15
2.6 Audio	17
2.7 Playback	17
2.8 Codec	18
2.9 Downscale and Clip Mode	19
2.10 Access clips on PC/MAC	20
3. SETTINGS AND ADVANCED OPERATIONS	23
3.1 Footages and Slate	23
3.2 Exposure and White Balance	24
3.2.1 Color Temperature List	24
3.2.2 Auto White Balance	24
3.2.3 Waveforms	25
3.2.4 Zebra	26
3.2.5 e-ND	26
3.3 Slow-Mo and Quick-Mo	27
3.3.1 Two Types of FPS	27
3.3.2 User-defined Sensor FPS	27
3.4 Custom LUT	28
3.4.1 Upload Custom LUT	28
3.4.2 Erase Custom LUT	28

3.5 Firmware Update and Option Upgrade	29
3.5.1 Firmware Update	29
3.5.2 Black Balancing.....	30
3.6 TimeCode and SYNC.....	31
3.6.1 TC port and TC cord	31
3.6.2 External TC	32
3.6.3 Beeper and SYNC.....	32
3.7 Configure Camera.....	33
3.7.1 Preset	33
3.7.2 Shutter Display Mode	33
3.7.3 Camera Fan and Core Temperature	34
3.7.4 ISO.....	35
3.8 Control Cameras with iPad (KineRemote).....	37
3.9 3D and SYNC	38
3.9.1 Steps to set the two cameras	38
3.9.2 Playback and Change Parameters	39
3.9.3 Clip Name for Post Workflow.....	39
3.10 Anamorphic Lens Support And 4:3 Recording	40
4. FAQ.....	41
5. TECH & SPEC AND CONNECTORS	44
5.1 Tech Parameters.....	44
5.1.1 MAVO LF SPEC.....	44
5.1.2 MAVO LF Frame Rate and FPS.....	46
5.2 Connectors.....	47
5.2.1 DC IN.....	47
5.2.2 CTRL.....	47
5.2.3 EXT	48
5.2.4 TC.....	48
5.3 Mechnaical Drawings.....	49
5.3.1 Physical Parameters for Body with KineMount.....	49
5.3.2 Body with KineMOUNT and EF Mounting Adapter (with KineBACK-W)	53
5.3.3 Body with KineMOUNT and E Mounting Adapter (with KineBACK-W).....	56
5.3.4 Body with KineMOUNT and PL Mounting Adapter (with KineBACK-W)	59

1. OVERVIEW

1.1 Interfaces and Buttons

The native mount is also KineMOUNT, which works together with Mounting Adapters to adapt different lenses. But lenses which are tailored for KineMOUNT can be mounted directly.

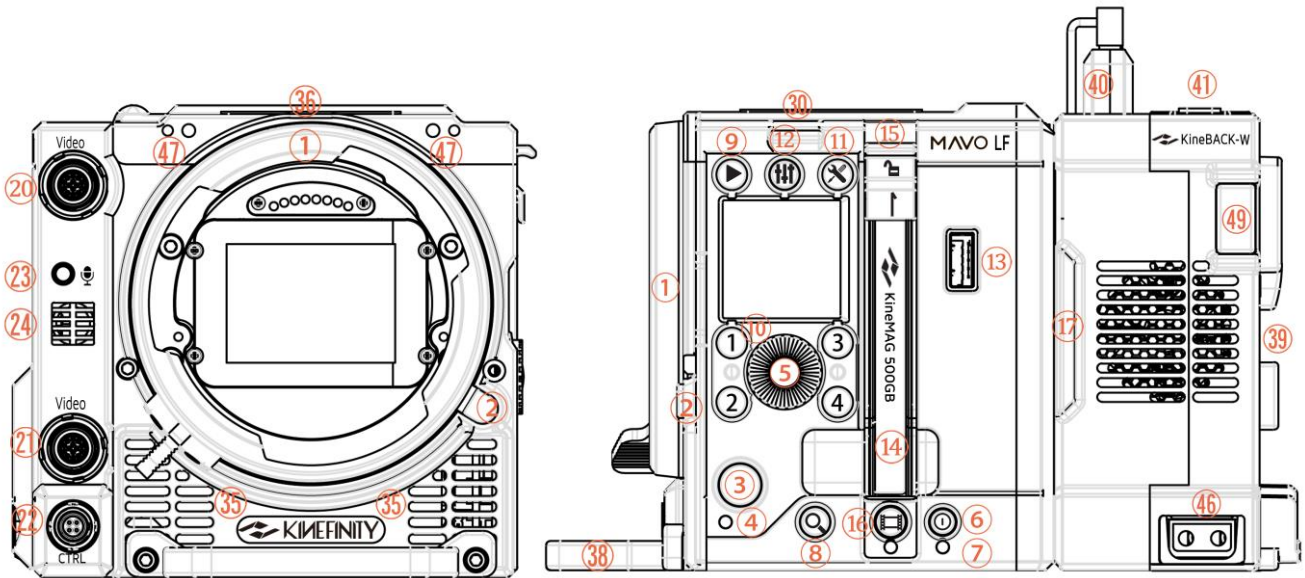

Front View (KineMOUNT)

Left View of Body with KineBACK-W (KineMOUNT)

#	Name	#	Name	#	Name
1	KineMOUNT	7	Power Status LED	13	USB Port
2	KineMOUNT Release Button	8	Zoom Button	14	SSD Slot
3	REC Button	9	Playback Button	15	SSD Latch
4	Tally LED	10	Shortcut Button 1~4	16	SSD Button
5	Wheel	11	Configuration / Play Button	17	Rear Air Intake
6	Power Button	12	Audio Button	18	KineBACK-W Port

More details about the professional ports on KineBACK-W will be introduced in the buttons review.

CAUTION Do not cover the air intakes at both front and rear of the body as well as the air vents at top and right side of the body.

CAUTION Camera has a new quick release port on the back of the camera, please be careful when installing/removing the KineBACK from the camera body.

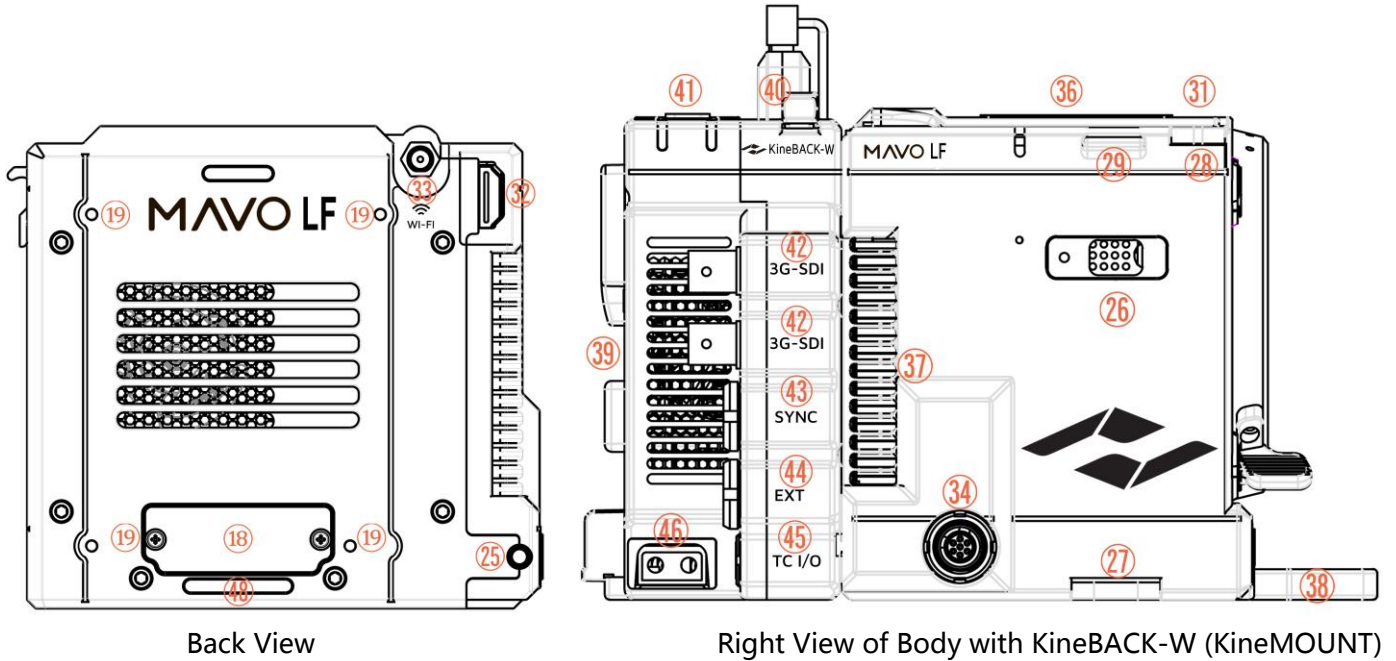

#	Name	#	Name	#	Name
19	KineBACK-W Screw Holes (M3)	31	Optical Mark (M2.5)	41	Audio XLR Port x2 (KineBACK-W)
20/21	Video Port	32	HD Type-A port	42	3G-SDI Port x2 (KineBACK-W)
22	CTRL Port	33	WIFI Antenna Port	43	SYNC Port (KineBACK-W)
23	3.5mm MIC Port	34	DC Input	44	EXT Port (KineBACK-W)
24	In-camera MIC	35	Front Air Intake	45	TC Port (KineBACK-W)
25	3.5mm Headphone Jack	36/37	Side Air Vent	46	D-Tap Power Output x2 (KineBACK-W)
26	SideGrip Port	38	Front Support (Detachable)	47	KineMON Screw Holes (M3)
27/28	SideGrip Screw Holes (M2.5)	39	V-mount Battery Plate (KineBACK-W)	48	KineBACK-W Positioning Hole
29/30	Shoulder Strap Hole	40	DT Transmitter Slot	49	Battery Release Button (KineBACK-W)

The definition of ports, please refer to [5.2 Connectors](#). SYNC and KineMON are proprietary.

1.2 Functions of Buttons

Under Liveview Mode, set the parameters by [Shortcut Button 1-4] and the [Wheel]; under Playback Mode, select and switch between clips by [Shortcut Button 1-4].

Operation	Function	Note
Rotate the Wheel	Iris Control/Select	Only for Lenses in <u>White List</u>
Cental Button	Switch Displays	Display with core parameters -> Display with Waveform , or Confirm
Button 2 Once	ISO/EI	Set ISO/EI Value
Button 3 Once	ND	Set ND (only with e-ND adapter)
Button 1 Once	Shutter	Shutter Angle or Speed
Button 4 Once	Color Temp	Set Complete List by menu
Button 2 Twice	FPS	Shooting (Sensor) FPS different from Project FPS
Button 3 Twice	LUT	Choose LUT (with e-ND adapter)
Button 1 Twice	N/A	
Button 4 Twice	Resolution	Set the resolution under the format

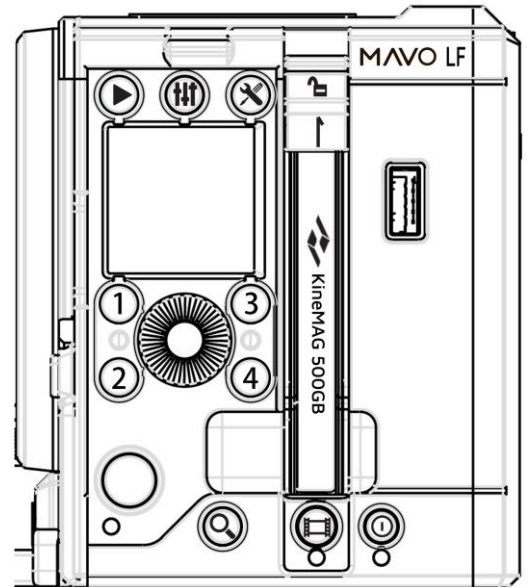

Buttons and wheel on SideGrip are basically the same as on the body, functions:

Button	Function	Note
	REC	REC; Switch from Playback to Liveview
	Shortcut List	Also play footage under Playback or cancel operation
	Zoom	Switch between 1:1/1:2/1:8, or disable the zoom in menu; press for 3 seconds to enter/quit lock mode
	Playback Mode	
	Configuration Menu	Also play footage under Playback mode
	Volume	Press twice to set audio
	Sleep Mode	Only on SideGrip, low-power standby mode
	SSD Button	Activate, deactivate or format SSD
	Power on/off	Press twice to power off; press for 5 sec + to power off compulsorily

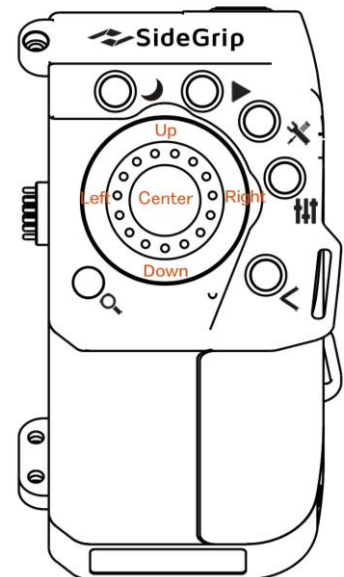

NOTE SSD Button is only on camera body; Sleep Mode Button is only on SideGrip. [Multifunction Wheel→Up] on SideGrip equals [Button 1]; [Multifunction Wheel→Left] to [Button 2]; [Multifunction Wheel→Right] to [Button 3] and [Multifunction Wheel→Down] to [Button 4].

1.3 Interface and Parameters

Once the camera is powered it enters into the Liveview mode right away: parameters of current scene are displayed on the top and bottom. Press [Wheel→Central Button] to show/hide Waveform.

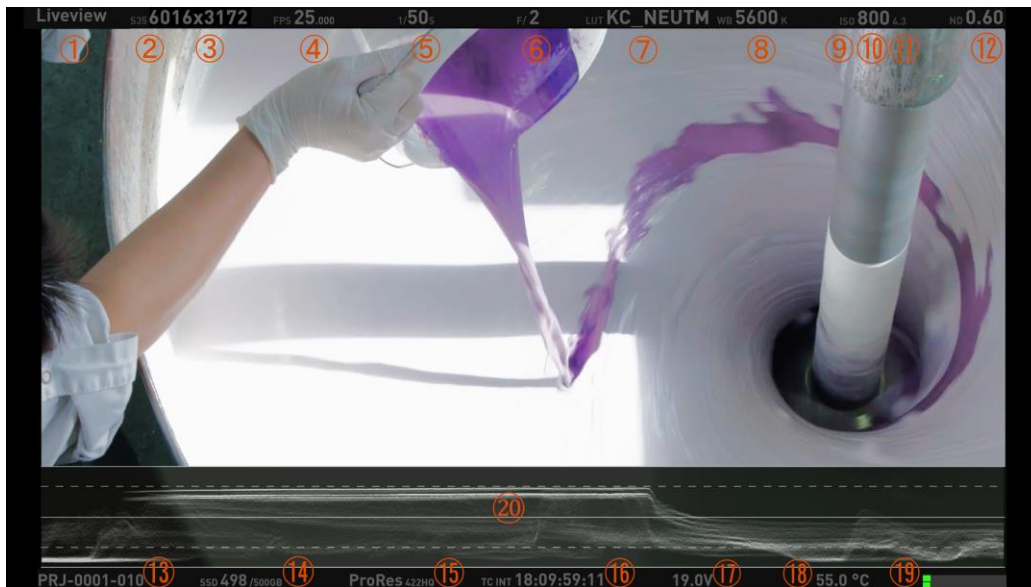

#	Name	#	Name
1	Display Mode: LIVEVIEW/PLAYBACK/REC	11	Highlight Level
2	Effective Sensor Frame Size	12	ND Value (only with e-ND adapter)
3	Record Resolution	13	Clip Name
4	CMOS Sensor FPS	14	SSD Status/Capacity
5	Shutter Speed/Shutter Angle	15	Record Format/Codec
6	Iris Number (If Applicable)	16	Time Code
7	Monitoring LUT	17	Real-time Power Voltage
8	Color Temperature	18	Real-time Core Temperature
9	Exposure Mode	19	VU meter
10	ISO/EI ASA	20	Waveform

NOTE **CMOS Sensor FPS** is the actual shooting FPS of CMOS, set by [Shortcut Button 2] and [Wheel]; Project FPS is the playback FPS of the footage in post work, set by [Config].

NOTE **EF Iris control** is only for lenses in the White list; other lenses might not be recognized or controlled.

1.4 Default Settings

The list below features the default setting of MAVO LF:

Type	Name	Default	Type	Name	Default
Shooting	Image Format	FF	Settings	SSD System Format	HFS
	Resolution	6K 6016*3172		Time Code	Free Run
	Sensor FPS	25fps		ND set	0.03
	Project FPS	25fps		WIFI Power	ON
	Shutter	1/50s		Threshold Voltage	12.5V
	ISO	ISO 800		Language	English
	Highlight Stops	4.3		Start Display	Brief
	Color Temperature	5600K Daylight		Fan Speed	30%
	LUT	KC_NEUTM		Fan Stop	Never
	Codec	ProRes 422HQ		Clip End	Loop
	Active Mount	Enhanced		SYNC	Tally Lamp
	Project Blanking	None	Beeper		ON
Liveview	Video Output FPS	60P	Audio	MIC Level	29.5dB
	Waveform	Post RGB		Playback/Monitoring Level	0dB
	Zebra Pattern	90%		KineAudio	OFF
	Color Temperature List	Brief		Phantom 48V	OFF
	Shutter Mode	Time		KineAudio Source	CH1/CH2
	Anamorphic Lens	None		KineAudio Level	30dB

NOTE When the camera is powered with an e-ND adapter attached, the default value will be 0.6 (2 stops).

How to restore to factory settings:

[Configuration → System → Factory Reset]

NOTE When the camera is powered with a USB storage device (doesn't matter what files it contains) plugged into the USB socket of the camera, the camera will restore itself to factory settings.

2. QUICK GUIDE

2.1 Power Supply

The camera allows different types of power supplies:

- **GripBAT 45Wh** (compatible with BP-U30) fits MAVO LF with SideGrip. Single GripBAT 45Wh can power the camera for 100 mins. SideGrip is connected to the "SideGrip Port" on camera body by three M2.5 screws, which enables a kind of "DSLR" shooting style.
- **Supper Compact V battery KineBAT 120Wh** (compatible with V-mount batteries) fits camera with KineBACK-W. Single KineBAT 120Wh can power the camera for more than four hours. KineBACK-W only comes in a V-mount version, and does work with other V-mount batteries. The EXT port of KineBACK-W also provides dual 12V outputs and two D-TAP ports. For a definition of EXT port, please refer to Chapter 5.2.3.
- Use different power cords to the 2-pin power port of camera body:
 - D-Tap Power Cord: connect the D-Tap plug to the D-Tap socket of battery/battery plate, and connect 2-pin push-pull plug to the 2-pin power socket of camera body;
 - XLR Power Cord: connect the 4-pin standard XLR plug to the XLR socket on storage battery (11~19V), and connect the 2-pin push-pull plug to the 2-pin power port on camera body;
 - Kine AC Power Adapter: connect the adapter to a power bar, and plug 2-pin push-pull plug to the 2-pin power socket of camera body.

CAUTION The input range is 11~19V, don't go above or the camera might be burned.

CAUTION Please pay attention to the direction of 2-pin DC IN port on the camera body while pulling/plugging the power cords: please align the red dots.

NOTE A V-mount to Anton-Bauer Plate Adapter is needed if you want to use Anton-Bauer (golden mount) broadcast batteries.

NOTE When two of the three power supplies are available at the same time, the camera will automatically choose the source with highest voltage, and allows hot-switch of batteries.

NOTE To save power, use other power supply for monitors and turn off WIFI.



1. DC IN as VDD
2. Ground

NOTE If there is a power failure during the recording of a file, the recorded clip might be damaged, please refer to Chapter [2.5 SSD Mag.](#)

2.2 Mount

MAVO LF is designed with a native KineMOUNT, which need a [Mounting Adapter II](#) to be able to attach a lens to the camera. The available adapters include [EF Mounting Adapter II](#), [EF Mounting Adapter II with KineEnhancer](#), [EF Mounting Adapter II with e-ND](#), [PL Mounting Adapter II](#), [PL Mounting Adapter II with e-ND](#), and also [SONY E Mounting Adapter](#).

There are only three steps to install a "Lens Mounting Adapter II" to the KineMOUNT, we will take EF adapter as an example, turn off the camera and then:

1. **Release:** keep pressing the KineMOUNT Release Button and rotate the locking ring of the KineMOUNT counter-clockwise → then take off the KineMOUNT cover;
2. **Install:** there is a positioning slot above the electronic contacts of the KineMOUNT, please align the arcuate protrusion on the adapter with the locating slot of KineMOUNT when attaching the mounting adapter to the camera;
3. **Lock:** Firmly rotate the locking ring of KineMOUNT clockwise to fasten the adapter to KineMOUNT firmly.

Power on the camera after mounting the adapter. Press [Configuration] and check the bottom of this menu, if it presents EF sys 9(or other number), it means you have mounted the adapter successfully.

CAUTION Power off camera when swapping different adapters, else camera or adapters may get burned.

CAUTION As the FFD of KineMOUNT is very short, please don't try to attach any lens directly to KineMOUNT, or it will cause permanent damage to CMOS sensor and OLPF.

NOTE The KineMOUNT only works with [Mounting Adapter II](#).

NOTE When install the [EF Mounting Adapter II with KineEnhancer](#) or [e-ND](#), please don't touch the optical glass. Any damage caused to the glass is irreversible, and the glass has to be replaced.

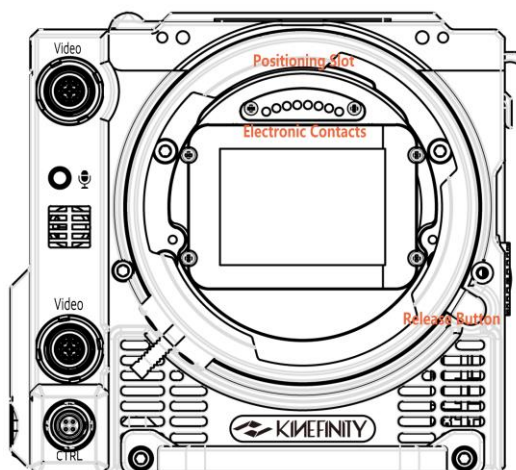

2.3 Lens

No matter if you attaching DSLR lens or PL cine lens, the camera employs a lock-style (Cine-style) mounting system, rather than a DSLR camera mount.

Steps to attach EF lenses

1. **Release:** Rotate locking ring of EF mount clockwise, take off the cover and lens cover;
2. **Install:** Align the “red dot” on the lens with the “red dot” on the mounting adapter. Make sure that the pin on mount engages with the hole in the mount of the lens. For EF-S lens, align the white square on lens with the one on the mount.
3. **Lock:** Rotate locking ring (NOT lens) counter-clockwise (follow the arrow of “lock sign” on mount) until it is fastened firmly.

CAUTION The mounting adapter might be burned if a lens/adapter with all-metal rear end is attached directly to the camera body. In this case, please keep electronic iris control off: [Configuration→Settings→ Active Mount→Disable].

NOTE The following mount lenses with electronic contacts: **Sigma18-35 T2.0** and **Canon18-80 T4.0**, may show iris value on UI, but please do not change the value by the Wheel, or it will cause the malfunction of the camera or the lens, we strongly recommend turning off the electronic iris control. [Configuration→Settings→ Active Mount→Disable].

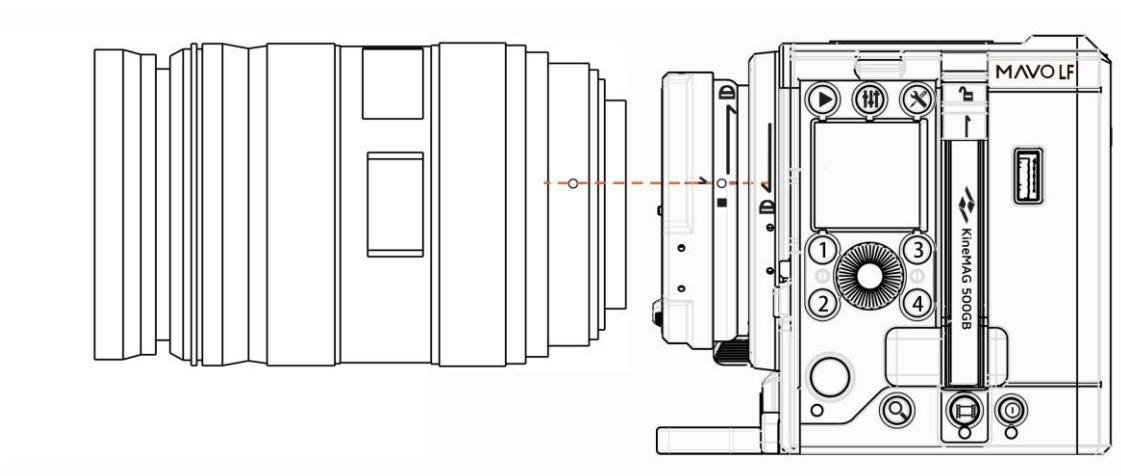

2.4 Monitoring

Please choose a recommended EVF or Field Monitors with Video, 3G-SDI (Not HD-SDI) or HD digital input, and connect the input port of EVF or monitor to output port of the camera body with high a quality cable.

Suggestions for monitoring:

- KineMON 5" Full-HD Monitor: with the Kine Video Cord our monitor gets both power supply and video signal through the same cable. There are many appropriate accessories available to firmly mount the monitor according different needs.
- SmallHD Monitors 500 series and 700 series: can be connected to the HD Type-A port and two 3G-SDI ports on the KineBACK-W.
- Zucuto Gratical EYE: a 3rd-party Micro-OLED EVF with SDI port can also be used on the camera with KineBACK-W. For a EVF with only HDMI port, Gratical X is a good choice.
- FSI broadcasting/cine monitor or other monitor with 3G-SDI port as director monitor or DIT monitor.

For the current firmware, HD Type-A port is only for video monitoring, but SDI port also supports audio signal: output audio during the playback of files.

CAUTION Use the HD video cable or SDI cable (75Ω) to connect the monitor and the camera before the monitor and camera are turned on. Please pay attention to the direction of the D-TAP cord.

NOTE When using the 3rd-party monitors, please choose the LP-E6 Battery Coupler (7.4V).

NOTE The video output is only for monitoring, not recording. The monitoring FPS is different from CMOS FPS; therefore, the external recorder cannot get the clips with the same FPS and resolution as CMOS sensor.

Functions of Buttons on KineMON

- PEAK: peaking focus, show the red line peaking as an overlay on a black-and-white image;
- CLIP: marks clip exposure, show the overexposure and underexposure area;
- False: marks false color exposure: overexposure/underexposure areas and the area between;
- Wheel: press the wheel to trigger backlight setting, and rotate the wheel to set the level of backlight.

NOTE Turn off the KineMON to save the power for longer duration.

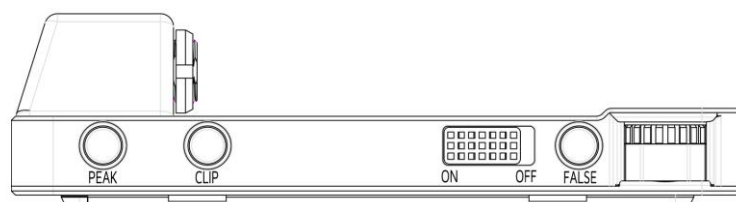

2.5 SSD Mag

Please employ the KineMAG 500G/1T SSD or other 2.5" 7mm SSD to SSD slot before power on the camera. The SSD slot has a secure latch: push the latch **upwards** before inserting or pulling out the KineMAG. The button under the slot controls the operation of the SSD, and the LED indicator beneath the button shows the status of the SSD.

Check the SSD status on the monitoring screens:

- Blinking red **[No SSD]**: the SSD indicator is off, which means that there is no SSD in the slot, you can not shoot. Insert the SSD into the slot and reboot the camera;
- Blinking yellow **[SSD: Ins]**: the SSD indicator is red now, which means that there is a SSD detected but hasn't been activated, you still can't shoot under this status. You need to:
 - Activate the SSD: press [SSD] button, and choose [SSD Maintenance → Activate] or twice-quick press on SSD button; if the SSD has been formatted into HFS or NTFS, it will be activated successfully showing SSD capacity and green **[SSD: Act]**.
 - Rebuild SSD: if fail to activate SSD, please rebuild it in camera. Press [SSD] button, choose [SSD Maintenance → Rebuild]. Then activate SSD, SSD status displays green **[SSD: Act]**.

Green **[SSD: Act]** with SSD available capacity and total capacity: SSD indicator is Green which means the SSD is ready for shooting and the clips will be recorded onto it.

Please make sure that the SSD is deactivated before taken out: press [SSD Maintenance → Deactivate] or twice on SSD button, SSD status turns into **[SSD: Ins]**, then push the latch upward and pull out the SSD.

CAUTION Data can't be recovered after rebuilt the SSD; please backup all data before formatting.

NOTE Please do insert the SSD before the camera is powered on, or the SSD will not be detected.

NOTE We only recommend KineMAG. Performance of 3rd-partyon data spec are not guaranteed. No technical support or help on recording issues such as frame drop or data loss for 3rd-partySSD. In addition, some 3rd-party SSD may damage the blade of SSD slot, such as Samsung 860 PRO.

NOTE Please prepare backup SSD cards in case of emergency on the set.

NOTE If it shows red "Flush" during recording, please try a KineMAG. If the issue still exists, please contact us by email: sales@kinefinity.com.

SSD File System Formats: NTFS & HFS

The camera supports both NTFS and HFS format for SSD. The default format is HFS, but for Windows platform, you can set it to format in NTFS by:

[Configuration→Settings→SSD File System] choose NTFS

Then reboot the camera and rebuild the SSD in camera, the file system of the SSD will be NTFS.

NOTE For Mac platform, you can still use NTFS: since MacOS 10.12 Sierra, MacOS can access NTFS files. Do not write data or format SSD on Mac or Windows.

NOTE Rebuilt/format the SSD in camera ONLY.

NOTE When the file system format of the camera is set to NTFS, the SSD of HFS can not be activated in the camera. Here are two solutions for such situation: change the format of the camera into HFS and then reboot to take effect; or back up your SSD on a computer, and then rebuild/format the SSD in camera as NTFS. MAKE SURE to back up your clips before you format SSD.

NOTE If the camera is out of power while recording, the NTFS SSD may not be activated when the camera is powered on again. Please back up your clips and then rebuild the SSD, or you have to use another SSD to continue the shoot. While HFS SSD can be activated for shooting after reboot, but the clip also needs to be recovered if to play back.

NOTE To recover the cDNG/ProRes clip damaged by power failure, please email us for detailed solutions.

2.6 Audio

There are three audio recording methods:

- In-camera MIC: can record audio using the in-camera MIC even there is no KineAudio or 3.5mm MIC;
- 3.5mm Plug-in-power port: suited for 3.5mm MIC;
- KineAudio dual XLR ports with Phantom 48V: KineAudio has a high-quality pre-amp audio module with Phantom 48V, and it is integrated into KineBACK-W. Also, it has dual industry-standard XLR ports for professional condenser microphones. Since KineOS 6.112, KineAudio CH1 and CH2 channel can be set independently.

If the camera has no KineBACK-W or KineAudio is disabled, audio will be recorded by 3.5mm MIC if a microphone is connected to the 3.5mm port; if no microphone is connected, audio will be recorded by the in-camera MIC.

NOTE The audio will be packed into mov file only when the project FPS is the same as sensor FPS, or it will be recorded into a separate mov file. For example, if the project FPS is 25.000, when the sensor FPS is set to 30.000, it will show yellow **30.000** on the UI.

KineAudio and Phantom 48V

If microphone needs Phantom 48V, you need to set the KineAudio: press twice the Audio button
[Audio Button→Audio Management→] [KineAudio: ON] and [Phantom 48V: ON]

Three modes for audio tracks:

- Two audio tracks as CH1: recorded two tracks as CH1;
- Two audio tracks as CH2: recorded two tracks as CH2;
- Stereo: recorded two tracks as CH1 (Default: left track) and CH2 (Default: right track) separately.

Generally, the camera audio can be set as one input if just using one MIC.

CAUTION For MIC does not apply Phantom power, please turn off the Phantom 48V.

2.7 Playback

While in Liveview mode, press [Playback] button and enter into Playback mode, and [Shortcut List] button and [Configuration] button act as Play/Pause button. Playback of the current clip is looped by default. Press [Shortcut Button 2] to the previous clip; press [Shortcut Button 4] to the next clip. You can also fast forward or fast reverse by step of 5 seconds. Please note that the parameters in Playback mode are different than the ones in Liveview mode.

Press [REC] button or [Playback] to switch back to Liveview mode.

NOTE Playback clip of 4K or lower resolution in the camera is fluent, but higher resolution will see stutter.

2.8 Codec

There are two in-camera recording codecs, set the default codec by:

[Configuration→Shooting→Default CODEC→ ProRes (.mov) /cDNG(.dng)]

We recommend shooting ProRes as the camera supports in-camera ProRes recording at all resolution and fps: 6K/5K/4K/3K/2K even 4K Wide 100fps. Besides ProRes422HQ, MAVO LF also supports ProRes4444XQ, 4444 recording and keeps all dynamic range of ProRes clips with KineLOG3, while the monitoring LUT will not be burned into the clips.

MAVO LF can in-camera record compressed RAW as well with cDNG format, and the compression ratio is configurable, from 3:1, 5:1 to 7:1. Da Vinci Resolve natively supports cDNG, so that you can directly import, edit and grade the cDNG footage shot by the camera in DaVinci Resolve! No matter what compression ratio 3:1, 5:1 or 7:1, every format is able to achieve super high quality image and room for post-production.

NOTE No need to reboot the camera when switch between codecs, but the screen will be black with a cross in the center for 3 seconds during the switch.

NOTE The camera supports ProRes4444XQ recording to 4K 48fps, ProRes4444 to 6K 30fps due to the ability limitation of SSD.

NOTE KRW code will be enabled in firmware in the first half year of 2019.

Duration Reference

Settings	Duration	
	@KineMAG 500GB	@KineMAG 1TB
2K@25fps ProRes422HQ	5 hours and 30 mins	11 hours
3K@25fps ProRes422HQ	2 hours and 50 mins	5 hours 20 mins
3K@25fps cDNG(7:1)	5 hours 20 mins	11 hours
4K@25fps ProRes422HQ	1 hour 20 mins	2 hours 40 mins
4K@25fps cDNG(7:1)	2 hours and 40 mins	5 hours 20 mins
5K@25fps ProRes422HQ	53 mins	1 hour and 40 mins
5K@25fps cDNG(7:1)	1 hour and 40 mins	2 hours and 40 mins
6K@25fps ProRes422HQ	42 mins	1 hour and 20 mins
6K@25fps cDNG(7:1)	1 hour and 20 mins	2 hours and 40 mins

2.9 Downscale and Clip Mode

In Comparison with the discontinued and older TERRA 6K, MAVO LF doesn't have HiSpeed. Due to the native, super fast sensor readout time of 8ms, the camera has a very low jello/skew effect, even with fast pans it's rolling effect is hardly noticeable and the readout time of this camera is comparable to the best and most awarded cameras in this industry. Because there is no need for the so called "Highspeed mode" , the sensor doesn't suffer from noisy images, aliasing and moire.

Oversampling/Downscale

Oversampling/Downscale: recording (output) resolution is less than actual sampling resolution by image sensor, while the image format of recording is the same with the image format of sampling. As all effective area of image sensor is used, there is lower noise level. Oversampling at FF is 4K/3K.

For most cases, downscale 4K ProRes at FF is recommended.

NOTE Due to the downscale in-camera process, there is no 4K/3K RAW under FF.

Cropping Mode

Cropping means that image sensor only utilizes an center part of image as effective sampling area. Cropping mode can boost fps higher than full resolution sampling:

- Output 6K Wide full resolution sampling, up to 75fps;
- Cropping Mode, 3K Wide (M4/3), up to 150fps;
- Cropping Mode, 2K Wide (S16), up to 200fps.

Oversampling + Cropping = infinity combination of resolution, fps and framing. Select Cropping Mode by:

Press [Shortcut Button 1] twice or [Configuration→Shooting→Image Format]

2.10 Access clips on PC/MAC

Access SSD on PC/MAC

To access Clips from SSDs on PC or MAC, a SATA to USB3.0 reader is used to connect SSD to workstation or laptop:

- MAC platform (MacOS Sierra or higher version) can access SSD with either NTFS or HFS file format;
- Windows platform can only access SSD with NTFS file format (format must be set as NTFS in camera).

NOTE We suggest to use the reader supplied by Kinefinity to access SSD. Some 3rd-party reader may not work.

Clip Folder

Each clip is saved in the SSD. The folder name is nearly the same as the clip name, just no file extension, for example: folder PRJ-0002-003-A2_5D8A (meaning of clip name, see [3.1 Footages and Projects Information](#)) includes:

- PRJ-0002-003-A2_5D8A.mov or PRJ-0002-003-A2_5D8B.krw: are ProRes mov file or KRW RAW file.
- PRJ-0002-003-A2_5D8A_L.wav and PRJ-0002-003-A2_5D8A_R.wav: are the uncompressed audio files of CH1 and CH2.
- *****.cube** and *****.look** are the LUT while monitoring, format is cube or look format.
- Curve.cube: one gamma curve 1D LUT.
- PRJ-0002-003-A2_5D8A_snapshot.bmp: the snapshot of this clip, resolution 1/2x1/2.
- Slate.txt: contains most of the information when shooting the clip, like shutter speed, ISO, highlight, color temp, etc.
- 0.mt: internal camera information when recording.

Please send slate.txt and 0.mt to Kinefinity if clip files show abnormal.

NOTE If Project FPS is the same with Sensor FPS (shooting FPS), audio will be recorded into ProRes mov file; else audio will be recorded into two wav files (in slow-mo or quick-mo).

NOTE When importing mov files into editing software, enter and search *.mov by the dialog box, all mov files will be listed automatically, then press CTRL+A / ⌘+A to select all mov files and drag them inside your NLE.

Play ProRes Clips on PC/MAC

All dynamic range of KineLOG3 ProRes clips is retained, and monitoring LUT will not be burned into the clips. Therefore, it is LOG clips retain all of their dynamic range and color information While playing the

footage at an computer use the LUT file that was used inside the camera and the image will look identical to the one while monitoring during the recording.

When using Windows you need to install Quicktime7 to access ProRes mov file, while other DI softwares such as SCRATCH, DaVinci Resolve do not need to install Quicktime7 to be able to work with those files. MAC platform can access or play ProRes files without other software tools.

Edit cDNG Clips on PC/MAC

The camera can in-camera record compressed RAW with cDNG format, and the compression ratio is configurable, from 3:1, 5:1 to 7:1, each is able to achieve super high quality image and room for post-production.

Da Vinci Resolve natively supports cDNG, so that you can directly import, edit and grade the cDNG footage shot by the camera in DaVinci Resolve! And cDNG is also natively supported by SCRATCH V9.0, LUT used on site is automatically applied when you input the cDNG clip into SCRATCH, and the audio track is also connected automatically.

For RAW files, they look different in DI tools. But SCRATCH V9.0 has optimized the process for clips of Kine cameras, applies the LUT you use automatically to the clip. After disabling the LUT, you will get the RAW clip with native KineLOG3, which looks the same with the ProRes clip plus KineLOG3, and you can add Kine NeutralM LUT or other LUT into it. While since Da Vinci Resolve doesn't have such optimization for the clips, the color will be quite different when inputting a cDNG file into Resolve. But we can set the RAW decoding settings to get the actual RAW clip with native KineLOG3.

1. Set RAW Project: open Resolve, then [Project Settings→Camera RAW];
2. Set decoding method: select [RAW Profile→CinemaDNG], and then choose [Decode Using→Project];
3. Set decoding details:
 - a. White Balance: choose [Cloudy];
 - b. Gamma: select [Linear];
 - c. Lift: set to 3.20;
 - d. Tint: unbox, and use default 10.00

After the settings are done, you can input cDNG files and get the clip with KineLOG3.

NOTE Compressed RAW is only supported by DaVinci Resolve and SCRATCH, but Adobe and other DI tools don't support cDNG for now.



3. SETTINGS AND ADVANCED OPERATIONS

3.1 Footages and Slate

When start a new project, please make sure:

- Project FPS: the fps used by playback clips, editing clips or delivery. For example: 24fps for movie, and 25fps for TV release (PAL). Project FPS should not be changed after project kicks off;
- Slate information, set clip name, director name, DoP and so on to the project, and you can find all the information in slate.txt.
- Codec: choose in-camera ProRes or cDNG RAW for recording;
- Project Blanking: can choose from 2.4:1, 2:1, 17:9, 16:9, 4:3 or Instagram ratio 1:1, also 9:16 and 1:2 for cellphone screens. Project Blanking is also suitable for anamorphic shooting.

Codec: choose based on the requirement of project, post workflow even the working habit of the colorist:

- In-camera ProRes: most of the projects can be recorded by ProRes 422HQ (visually lossless), and in-camera oversampling to 4K/3K ProRes with high image quality, efficiency and reliability;
- Compressed RAW cDNG: can in-camera record compressed RAW with CinemaDNG format (compression ratio 3:1, 5:1 and 7:1) which is natively supported by DaVinci Resolve.

Set the project information, such as Project Name, DoP Name, Roll Num, Take Num and so on, in [Configuration]

- Set Project FPS: [Configuration→Shooting→Project FPS]
- Set Slate: [Configuration→Shooting→Slate]
- Set Project Blanking: [Configuration→Shooting→Project Blanking]

Use the Shortcut Button 1~4 to change the information. All will be listed on the Slate and the SSD Roll Label, see eg:

Before a new project, suggest setting the Scene Num, Roll Num and Take Num as "1". Then the Roll Num of the SSD card will be added 1 each time of shooting after formatted in the camera, convenient for DIT to back up clips.

NOTE Project Blanking only acts as a reference for monitoring, camera will record the full active image.

Menu Operation

Change Project FPS

[Configuration→Shooting
→Project FPS]

Menu Operation

Set Project Information
[Configuration→Shooting
→Slate]

Clip Name

PRJ-0002-003-A2-5D8B

- PRJ: Project Name;
- 0002: Scene Num;
- 003: Take Num;
- A: Camera Unit;
- 2: Camera Num;
- 5D8B: random numbers

SSD Roll Label

A002_6D09B6

- A: Camera Unit;
- 002: Roll Num;
- 6D09: First Four Digits of Serial Number;
- B6: Random

NOTE For 3D shooting or multi-cam SYNC, please refer to [3.9 3D and SYNC](#).

3.2 Exposure and White Balance

The color temperature is tuned by directly adjusting RGB channels of sensor to change original RAW data, rather than apply a digital LUT. Although you can modify white balance of RAW data or change color temperature by post processing, all the modifications are based on the data you shoot previously. In order to minimize the distortion in post processing, it is important to gain as accurate color temperature as possible in shooting stage.

3.2.1 Color Temperature List

The camera has two types of color temperature lists for white balance: Simple List and Complete List.

- Typical List: with typical color temperatures such as 2800K, 3200K, 4300K, 5500K, 5600K, 6400K and User WB. Among them, UserWB is user-defined value, which is automatically generated when do the Auto WB manually.
- Complete List: complete color temperatures according to the portfolios of color temperatures (in accordance with the 100K for a step) and lighting types. You can simply choose the one to match with your shooting condition.

To change color temperatures: [Configuration→Liveview→ Color Temperature List]

3.2.2 Auto White Balance

For most cases, the Complete List of color temperature can meet the need. However, if the color temperatures listed in the built-in lists are not enough to meet complex shooting lighting conditions, use a gray card or white card to do Auto WB to achieve specific color temperature. To do the Auto WB:

1. Put a gray card at front of the camera;
2. You may Zoom to make the grey/white card cover the whole display;
3. Choose: [Configuration→Liveview→ Custom White Balance]

Menu Operation

Change Color Temperature List
[Configuration→Liveview → Color Temperature List]

Maunal Operation

Auto WB
[Configuration→ Liveview→Custom White Balance]

The camera corrects the white balance parameters, and writes the color temperature value to the UserWB. Once the UserWB is set, it can be used anytime later.

3.2.3 Waveforms

Waveforms, zebra and histogram help cinematographers determine the exposure of images. Waveform at the middle of UI indicates the brightness of images over the horizontal direction, while histogram in the lower right corner of UI shows the statistical information on the brightness of whole image.

The Waveform matched the images by default, and shows the LUT NeutM, too. Waveform will change according to the different LUT. You can also choose to check the waveform of pure RAW with KineLOG3 by [Configuration→Liveview→Waveform]

You can choose different displays for waveforms and:

- **Post RGB:** The histogram information displays distribution of RGB, which is based on RAW data after the processing of monitoring LUT loaded.
- **RAW RGB:** The histogram information display R/G/B three color channels distribution based on the RAW data. It is pure RAW with KineLOG3.

NOTE When over 100% on the waveform of Post RGB, images do not mean overexposure definitely, only over 100% on the waveform of RAW RGB, images are sure to be overexposed.

NOTE By waveforms, it is important to make sure that the main image is over 50% and the background is with proper exposure to avoid unnecessary noise.

Menu Operation

Switch between different data resources

[Configuration→Liveview→Waveform]

3.2.4 Zebra

Zebra strip is a very straightforward way to show the overexposed area in image.

For Kine cameras, the zebra calculation is based on RAW data: RAW data is overexposed when the zebra appears. So observe carefully to avoid unintentional over-exposure in most cases, as it is the "dead white" in the post workflow.

Zebra threshold value can set in different value:

[Configuration→Liveview→Zebra Pattern]. The default threshold value is 90%: it means that it will display zebra when the light exceeds 90% of the maximum range.

3.2.5 e-ND

E-ND refers to electronic ND (Electronic Neutral Density Filter), it is based on modern liquid crystal materials and optics controlled electronically, which is completely unlike conventional technology such as a rotating filter wheel or polarising ND Filters. It covers a wide range from 0.6 to 3.0 (2 stops to 10 stops), and brings sharp images with color fidelity.

Seamless adjustment brings a very important feature: accurate exposure stop, which is what traditional glass ND filters don't have. You can also set the accuracy to one stop(0.3) for each rotate, but the default set is seamless adjustment by 0.1 stop (0.03).

NOTE E-ND is only embedded to EF/PL adapters, but not the camera body.

Menu Operation

Set Zebra Threshold

[Configuration→

Liveview→Zebra Pattern]

Menu Operation

Set e-ND

[Configuration→

Settings→ND Adjust]

3.3 Slow-Mo and Quick-Mo

3.3.1 Two Types of FPS

Sensor fps: It is the capturing fps of sensor. Shown on the up center on the UI as well as on the slate, can be set by the [Shortcut Button 2].

Project fps: It is the fps which used by playback clips, editing clips or delivery. You can choose one of them based on your need. For example: 24fps for movie and 25fps for TV release (PAL). Set the Project FPS:

[Configuration→Shooting→Project FPS]

When the Project fps is set to 25fps, whatever you set your sensor fps, clips will be played at 25fps in post-production or in-camera playback. For example: we usually choose 22fps Sensor fps for shooting action movies, but choose 25fps for playback. It makes the actions seems faster when playback. The factory setting of project fps is 25fps.

3.3.2 User-defined Sensor FPS

For regular fps, like 24, 25, 30, 48, 50, 96, 200, are available in FPS Shortcut List, for other fps, custom by menu: [Configuration→Shooting→Custom Sensor FPS].

You can define three fps to any value between minimum fps (0.2fps) and the max fps of current resolution w/ accuracy 0.001fps.

- Define the sensor PFS to 22fps, there will be 22fps option in the sensor shortcut list at any resolutions;
- Define the sensor FPS to 149fps, the 149fps option would not appear at S35 4K resolutions, but will appear in the Sensor fps menu at M4/3 3K resolutions.

You can delete the customized Sensor fps by modifying it to 24 fps.

NOTE

When shoot slow-mo or fast-mo (Sensor FPS is different from Project FPS), the audio track will not be packaged into mov file if the record codec is ProRes mov or transcoded by KineStation, but two uncompressed audio files are in the clip folder.

Shortcut List

Change Sensor FPS
[Shortcut Button 2] twice

Menu Operation

Change Project FPS
[Configuration→Shooting
→Project FPS]

Menu Operation

Custom sensor FPS
[Configuration→Shooting
→Custom Sensor FPS]

3.4 Custom LUT

The camera supports custom LUT perfectly: from shooting to post with custom LUT. There is one in-camera preset LUT: KC_NeutM. KC_NeutM has more accurate highlight and details in shadow than Kine709 and covers balanced tone, normal saturation and contrast.

You can upload LUT to the camera, switch different LUT/Look instantly when monitoring. Record KRW or ProRes with custom LUT; it does not burn into footage: RAW is RAW, on-site LUT for monitoring is dumped to clip folder. It is suitable for fast project if the exposure is proper while shooting.

You can upload 3rd-party LUT to the camera as many as you want; supporting up to 33x33x33 3D LUT Cube, SCRATCH and DaVinci Resolve can output cube LUT.

3.4.1 Upload Custom LUT

It just needs three simple steps:

1. Output from DI software and rename it, rename the LUT into four letters in English, like CAN1.cube;
2. Copy the LUT into root folder of USB stick as FAT/FAT32;
3. Upload to the camera: insert USB stick to USB port:
[Configuration→LUT→Load Custom LUT]; it only takes one second.
Reboot the camera, and the new LUT will be shown in the LUT shortcut list if press [Shortcut Button 3].

NOTE The LUT will be overridden, if the name is same, and there should be no blank in the name and not more than four letters.

Menu Operation

Load Custom LUT

[Configuration→LUT→Load Custom LUT]

3.4.2 Erase Custom LUT

Erasing the uploaded custom LUT is also instinctive,

[Configuration→LUT→Clean Custom LUT]

Then all custom LUT will be deleted in a second, and only native KC_NeutM will be remained.

Menu Operation

Erase custom LUT

[Configuration→LUT→Clean Custom LUT]

3.5 Firmware Update and Option Upgrade

Updating firmware is easy and quick: download firmware from Kinefinity website, prepare a USB thumb as FAT32. Besides, you can also downgrade to the previous firmware version.

3.5.1 Firmware Update

The firmware version is shown at the bottom of CONFIG menu, for example, firmware: KineOS V6.2 (02), means KineOS version is 6.2 with building number of 6202. Upgrade the firmware as following steps:

1. **Download:** Download the latest firmware, and copy it to the root folder of a FAT32 USB disk; insert the USB disk into USB socket of the camera; there will be an usb label in the UI;
2. **Update:** do [Configuration→System→Update Firmware]. Confirm to upgrade, wait about fifteen minutes till the successful display comes out;
3. **Reboot:** Power down, and get USB disk out. Power on, and then the new firmware takes effective.

Menu Operation

Update Firmware

[Configuration→System→
Update Firmware]

If the camera shows the USB information but cannot update the firmware, please refer to [the FAQ](#).

CAUTION Do NOT take any other operation and Never lose power when update firmware, else it may lead to failure of firmware update, even camera has to be sent to Kinefinity for repair.

NOTE It is highly recommended that user should restore to factory settings and do black balancing after the update.

3.5.2 Black Balancing

Each Kine camera has gone through black balancing before shipping, which is done under Calibration Mode. After a long period of usage, please do the balancing again, and factory reset would not change the balancing data.

After upgrading to KineOS 6.1, please do as following:

4. Enter into Calibration Mode: hold configuration button when press and release power button, after three seconds, release configuration button;
5. Balancing: put on lens cover or mount cover to make sure a total black display, then [Configuration → System → Black Balancing], it will take about 5 mins;
6. Factory Reset: [Configuration → System → Factory Reset], then reboot camera.

Menu Operation

Black Balancing
[Configuration → System →
Black Balancing]

CAUTION Please do reset to factory settings, or camera will stay in calibration mode after reboot.

NOTE After black balancing, there is no dead pixel in normal ISO, but there might be a few red/green/blue spot when ISO is extremely high.

NOTE If there is white dot in some frames, it may be due to the cosmic rays, not the malfunction of CMOS sensor.

3.6 TimeCode and SYNC

Timecode is one of key features of cinema camera. The camera shows time code in the Liveview and Playback state. Timecode is written into recorded clips. For ProRes, the mov file contain a single timecode track; for RAW, every single frame contains a specific timecode, and the generated mov will contain the timecode track if you use KineStation to transcode them.

The camera has three types of timecodes:

- Free run: timecode runs all the time, no matter recording or not, and the timecode will be embedded into recorded clips;
- Record run: timecode runs only when recording, and does not run if Liveview. Suggest set timecode to 00: 00: 00: 00 when a new project begins;
- External TC: the camera can use timecode from external device like Ambient NanoLockit as timecode of camera: using special cable to connect timecode generator to TC port (on KineBACK-W), then set timecode source as external in the menu.

To set the timecode:

[Configuration→Settings→TimeCode]

Choose the timecode mode or reset the timecode.

3.6.1 TC port and TC cord

The TC port is MOCO 0B 5-pin port as definitions right side. It is compatible with ARRI Alexa camera TC port for LTC IN and OUT.

For timecode generator based on Ambient timecode system, such as NanoLockit, also a 0B 5-pin port; check the TC cord on Kinefinity website or contact sales@kinefinity.com.

In addition, the camera can output timecode to other devices: connect the TC input port of the device to the TC output port of the camera by a special TC cord.

NOTE The external mode doesn't support Jam TC input.

Menu Operation

Set the TimeCode

[Configuration→Settings
→TimeCode]

Port Definition



1. GND
2. LTC IN
- 3,4. NC
5. LTC OUT

3.6.2 External TC

There are three kinds of frame rate when using external TC: Project FPS of TERRA, Sensor FPS of TERRA and External FPS of TC generator. From KineOS 6.1, ONLY make sure that the Sensor FPS is an integral multiple of the External FPS.

Timecode on UI will be green if you successfully set the system. If there is no external timecode feeding into the camera, it will automatically employ the internal timecode of the camera and show Yellow. If the timecode blink green/red/yellow, you need to check if there is:

- Improper settings on the frame rates
- Poor cable connection;
- Power loss of external timecode device;
- Special settings needed for the timecode device. For example, NanoLockit TC output needs to be activated manually.

3.6.3 Beeper and SYNC

The beeper has two usages:

- It makes a tone of 1KHz and 2KHz respectively when trigger on/off record, to give signal to crew in the field. You can disable the beeper by:

[Configuration→SYNC→Beeper: on/off]

- It records a tone of 1KHz and 2KHz at the beginning of the video and end of the video when trigger on/off record, as pilot for post-workflow. Disable the function by:

[Configuration→SYNC→Recording Beeper: on/off]

Menu Operation

Set Beeper

[Configuration→SYNC→

Beeper: on/off]

Menu Operation

Set recording of Beeper

[Configuration→SYNC→

Recording Beeper: on/off]

3.7 Configure Camera

The camera can set shortcut list, body fan speed, EI/ISO mode, and shutter mode, etc. When power on with USB disk, the camera will be set to factory reset.

3.7.1 Preset

In-Camera Presets are a set of parameters for recording and shooting:

Image Format; Resolution; FPS; Shutter Speed; Record Format

Moreover, there are eight in-camera presets, and it provides quick switch for these presets: press [Shortcut Button 1] twice to pop up the Preset Shortcut list.

Besides, customers can define and save these in-camera presets. After setting these parameters in Liveview state, then:

[Configuration→Shooting→Save as Preset]

You will find the preset you save on the shortcut list.

3.7.2 Shutter Display Mode

There are two modes for shutter display: Shutter Speed and Shutter Angle:

[Configuration→Liveview→Shutter Mode: Time/Angle]

Calculation between Speed and Angle, if Shutter Speed is 1/50s, and fps is 25, and then the shutter angle is:

$$25 * 360 * (1/50) = 180 \text{ Degree.}$$

The Shutter Angle ranges from 0.7~358 Degree; the Shutter Speed has min value 1/2000, and the max value depends on the FPS.

Besides, Shutter Speed List does NOT match Shutter Angle List.

NOTE Set appropriate shutter speed to avoid flickering: for example, 1/50s, or 172.8 Degree.

Menu Operation

Change Presets

[Configuration→Shooting
→Save as Preset]

Menu Operation

Change Shutter Display

[Configuration→
Liveview→Shutter Mode:
Time/Angle]

3.7.3 Camera Fan and Core Temperature

Core Temperature is the real-time temperature of core processor, not the body temperature. It is shown in the Liveview and bottom of Configuration menu, so that users can monitor it. If the core temperature reaches up to 80 degrees, the temperature indicator turns into yellow number; up to 90 degrees, indicator turns red, camera needs to be cooled down or even turned off for safety, else it may bring permanent damage to camera body.

Two fans inside the camera for cooling:

- Core Fan: cools the Core Processor; the fan runs quietly for most of time, and can NOT be set manually;
- Body Fan: cools the whole camera body, can be set manually.

You can adjust the body fan speed (factory set: 30%) from 15% to 100% or even turn off: [Configuration→Settings→Fan Speed].

Besides, you can choose to stop the Body Fan while recording, and there will be less noise; the fan will be turned on automatically when stop recording: [Configuration→Settings→Fan Stop].

Menu Operation

Change Fan Speed
[Configuration→
Settings→Fan Speed]

Manu Operation

Stop Fan
[Configuration→
Settings→Fan Stop]

3.7.4 ISO

EI / ISO is a group of settings to capture light on the Sensor. Displayed at the upper right corner of the main interface, MAVO LF supports ISO and EI mode.

ISO Mode

Nominal value of ISO is ISO ASA, takes effect on the RAW data, applying different gain on the CMOS sensor. The default mode is ISO mode, ISO800, Highlight level (Highlight, that is 18% gray to ADC Clip) is 4.3 stops.

Under the same highlight level, when lower the the ISO value, the latitude of CMOS will be close to the darker part, which helps lower the noise and keep more details. Otherwise, when under low light condition, you have to set the ISO higher than 800 to increase the sensitivity of CMOS, but will increase the noise and keep less details at the same time (high light spots will expose or overflow).

Highlight Stops

As the name suggests, more highlight stops less shadows details. Less shadows may mean more noises. If retain more highlight details, suggest higher than 4.3 stops or use EI mode. Changing ISO won't change highlight stop.

Change Highlight Stops: sensitivity unchanged, the image brightness and dynamic range unchanged, while Only Highlight and Shadow stops changed.

To set the Highlight stops: [Configuration→Shooting→ISO Highlight Stops], choose from 3.3~6.3 stops. Under each highlight stop, camera will have minimum ISO value, for example: highlight stop is 3.6, minimum ISO will be 200, while for 4.3 stop, minimum ISO 320.

EI Mode

The nominal EI value, like Alexa or RED camera setting. Change value of EI affects the Highlight and shadow stops, image brightness adjusted by digital gain while the CMOS image sensor analog gain unchanged.

Change EI: sensitivity and dynamic range unchanged, while highlight and shadow stops changed, and image brightness changes. Switch between EI/ISO:

[Configuration→Shooting→Sensitivity Mode].

NOTE At LiveView, 18% grey matches E/I value to maintain the same lightness of shooting and post.

Menu Operation

Set Highlight

[Configuration→Shooting
→ISO Highlight Stops]

Menu Operation

Change Sensitivity Mode
[Configuration→Shooting
→ Sensitivity Mode]

NOTE

Suggest shooting at ISO mode if you are not completely understand the EI and ISO mode.

Dual ISO

MAVO LF is with Dual Native ISO: 5120/800, which allows it to capture low-noise and wide-latitude images in regular scenes or low-light environment very easily. When highlight level is 4.3, the native ISO for range from 320 to 1600 is 800, and 5120 for range from 1600 to higher ISO. For EI mode, native EI for range from 200 to 2560 is 800, and 5120 for range from 2560 to higher ISO.

3.8 Control Cameras with iPad (KineRemote)

If the camera is configured with WIFI option, you can use iPad (iOS 10 or below) to control the camera.

KineRemote APP is now available in App Store (iOS 10 or below), search Kinefinity or KineRemote, then download and install.

Turn on WIFI: [Configuration→Settings→WIFI Power: On].

How to use KineRemote:

1. Set camera: Plug in Antenna to WIFI socket, and turn on the camera. A wireless hotspot (AP) will be generated by camera automatically such as kinefinity_5D8A, 5D8A stands for the first four digits of the camera serial number.
2. Set iPad: Run KineRemote App installed on iPad: [Setting→WIFI], and choose to connect kinefinity_5D8A.
3. Open the APP: open the KineRemote, if you see the Timecode running, it means you have successfully connected the camera to your iPad.

You can directly modify a parameter in KineRemote App by finger tap. For example, to changes shutter, tap shutter Angle to pop up shutter setting list, tap the Up or Down button with your finger to desired value, and click blank space to confirm and exit.

NOTE LOOK is for Iris if attached an EF lens.

NOTE You need close the KineRemote in background when KineRemote does not show parameter properly. Then open it again.

Menu Operation

Turn on WIFI

[Configuration→

Settings→WIFI Power: On]



3.9 3D and SYNC

Two cameras with KineBACK-W can realize real 3D shooting; you can shoot multiple cameras in total sync with more cameras and KineSYNC box.

For Kine cameras in sync state, the sensors are almost completely synchronized: time code synchronization, frame synchronization and scanning synchronization with less than 5us mismatch. You need to prepare:

1. Each camera equipped with KineBACK-W (3D shooting option embedded); all cameras with the exact same firmware;
2. One or more 3D SYNC cables;
3. For multi-cam SYNC, a KineSYNC box is a must.

NOTE One KineSYNC Box can help a Master to synchronize seven slaves. To synchronize 32 cameras, you will need $32/7=5$ KineSYNC Boxes.

3.9.1 Steps to set the two cameras

For 3D shooting:

1. **Connect** the cameras: power off the two cameras, and connect them with 3D SYNC cable to their SYNC ports on KineBACK-W;
2. **Settings**: Set shooting parameters of the two cameras to the same, such as: shutter, sensor fps, project fps, resolution, ISO, highlights, etc. (suggest factory reset at first);
3. **Naming the clip**: [Configuration→Shooting→Slate] Please set the Lens number of Master to 0001, and slave one to 0002, which represent the left eye clips and the right eye clips. All the other clip parameters must be set exactly the same, except clip names;
4. **Auto WB** with grey or white card for two cameras respectively, so that they gain consistent color temperature;
5. **SYNC**: choose one camera to set: [Configuration→SYNC→3D Master], and the other one: [Configuration→SYNC→3D Slave], then a sync confirmation pops up to confirm the serial number of the Master camera.

After confirming the connection, **Master/Slave** in Green font appears on the upper left corner of the screen, then press REC button of the Master Camera, two cameras shoot fully consistent clips, which match the left eye and right eye respectively.

Menu Operation

Set Project Information

[Configuration→

Shooting→Slate]

Menu Operation

Set 3D Master

[Configuration→SYNC→
3D Master]

Menu Operation

Set 3D Slave

[Configuration→SYNC→
3D Slave]

3.9.2 Playback and Change Parameters

In current firmware version, playback is not supported in 3D yet, and you can only playback in 2D mode. Therefore, you have to exit 3D settings firstly:

If you want to change parameters, please exit from SYNC mode and set the parameters before you SYNC the camera again when Liveview.

Here are the steps:

1. Exit from SYNC: please press Configuration or Playback button on the Master Camera, choose [Disconnect 3D Sync] in the pop-up window. The Master Camera turns into 2D/Single operation mode, and the SLAVE enters SYNC mode: Green **Slave** will become Yellow **SYNC** indicating that the Slave Camera enters into the standby state.
2. Change parameters: set the parameters for shooting or play back clips;
3. Sync again: set the 3D menu of the Master Camera, and connect the Slave Camera again.

During the process, you don't have to set the Slave Camera, meanwhile, the 3D SYNC cable keeps connecting the two cameras.

3.9.3 Clip Name for Post Workflow

After the 3D shooting, the names of Master Camera and Slave Camera will be:

- PRJ-0002-003-A1-5D8B.mov
- PRJ-0002-003-A2-5D8B.mov

They represent the Left eye clip and Right eye clip. A1 and A2 stand for lens number just as you set before shooting, A1 is the Master camera, A2, the Slave Camera.

In this case, even you put all clips under one folder, there won't be naming conflicts, and all the right eye clips are adjacent to the corresponding left eye clips naturally.

For the naming of clips in details, please refer to Section [2.10](#).

Menu Operation

Exit from SYNC mode

[Configuration→

Disconnect 3D Sync]

3.10 Anamorphic Lens Support And 4:3 Recording

Anamorphic was a technical choice for filming, but now an aesthetic preference. Echo to more affordable anamorphic lenses, TERRA 4K, MAVO and MAVO LF are also good choices for anamorphic shooting, as the sensors are all 3:2. For MAVO LF, the full frame 36x24mm sensor allows:

- S35 anamorphic;
- Full frame anamorphic, which equals to 65mm;
- Open Gate: 6016×4160, all pixels of the CMOS imaging sensor are captured, leave maximum room for post processing.

The camera supports 2x, 1.8x, 1.75x, 1.5x, 1.33x, 1.25x, 0.5x anamorphic shooting, which falls into almost all anamorphic lenses in the market.

When use 2x anamorphic lens:

Format	Resolution	FPS	De-Squeezed
FF 3:2 Open Gate	6016x4160	40	12032x4160
FF 4:3 Ana	5376x4160	40	10752x4160
FF 6:5 Ana	4864x4160	40	9728x4160
S35 4:3 Ana	4096x3072	50	8192x3072
S35 1:1 Ana	3072x3072	50	6144x3072

Menu Operation

Set Anamorphic Lens
 [Configuration→Liveview
 → Anamorphic Lens]

For monitoring when shooting at 4:3 with anamorphic lens, you can de-squeeze the images into normal image by setting anamorphic lens factor in Configuration menu. For example, anamorphic lens factor is 2, set the factor in camera to 2, then you can get 2.66:1 instead of normal view of 4:3.

Set the ratio: [Configuration→Liveview→ Anamorphic Lens]

NOTE The in-camera clips are 4:3 instead of de-squeezed and monitoring depends on the ratio you set. To get normal monitoring, you can match the lens with proper ratio, but the actual clips are still 4:3.

4. FAQ

If there is an issue about the camera or accessory, please check the related chapter in this manual. Still need help, please make a short video and fill in the issue report on [issue report page](#). We will contact you within one working day. The issues below are mostly due to improper operation of accessories or camera settings.

1. Windows OS cannot get access to SSD:

- Please check if the file system of KineMAG+ is NTFS. To change the format into NTFS before recording, you need to set: [Configuration→Settings→SSD file system: NTFS], then rebuild the SSD in the camera.
- Try another SSD reader.

2. Press REC button, camera does not record, no tally light.

Please insert the SSD into the camera before power on, rebuild the SSD into NTFS or HFS and activate it, if the SSD indicator shows green, the SSD is ready for recording.

3. Camera stop recording automatically after a few seconds when recording:

- Check if your SSD has no capacity, and it shows red on the UI;
- Check if you use KineMAG+ SSD: if you use 3rd-party SSD, its speed may not be fast enough.

4. No signal on Monitor:

- Power off camera and connect output ports on the camera body to the input ports of monitors with high quality HDMI cable. Power on the camera and monitors after all parts set up well.
- Power off the monitor and reconnect the video cable.

5. Monitoring seems dropping or skipping frame, stutter when camera pans:

It is normal for monitoring when panning, but recorded clips do not drop any frame if using KineMAG SSD.

- Skipping frame on monitoring: monitoring signal from Kine camera is based on 25fps progressive (or other CMOS sensor fps), not 50i;
- Skipping frame when playback on workstation: if recorded clips are 25fps, less than 30fps, the clips will show it. If recording 50fps, and playback at 50fps, it will be much better.

6. No images from SDI on KineBACK-W:

- Check if the monitor supports 3G-SDI, as the output of KineBACK-W is 1080p;

- Restore to factory reset: [Configuration→System→ Factory Reset], or power on the camera with a USB thumb connected to USB port.

7. No audio when playback the clip

Please check if the project fps is the same with sensor fps, if not, the audio will not be packed into the clip, but be saved as two wave files to the clip folder. For details, see 3.3 Slow-Mo and Quick-Mo.

8. Iris of electronic EF lens cannot be adjusted:

- Make sure attach EF lens to EF mount in right way: please refer to [Section of Quick Guide – Lens](#);
- Make sure Active EF mounting adapter assembled well if camera body is version of KineMOUNT: please refer to [2.2 Mount](#). Both native EF mount and EF mounting adapter will show the "ef sys" + version number under the menu;
- Make sure the EF lens is compatible with Kine cameras: [Whitelist for lens](#);
- Make sure the iris control disabled: [Configuration→Settings→Active Mount→Disable]

9. There is no sound after inserting with XLR MIC of KineBACK-W:

- Make sure the well connection between KineAudio port and the MIC;
- Turn on KineAudio: press twice on Audio button or [Configuration→Audio→KineAudio: ON];
- Turn on Phantom 48V if using phantom powered MIC: press twice on Audio button or [Configuration→Audio→Phantom 48V: ON]

10. KineOS cannot update camera with new firmware:

- Check whether [USB] shown in the UI after USB stick is inserted to the USB socket of camera, else change another USB socket to try it;
- Check U disk is FAT32, NOT NTFS, or HFS;
- Check firmware is stored at the root folder of U disk, and no other firmware files in the same place;
- Rebuild the U disk as FAT applying MBR partition.

11. Black screen with a cross while switch between the codecs:

You don't have to reboot the camera when switch between KRW and ProRes, but the screen will be black with a cross in the center for a few minutes, this is not a failure or a bug.

12. Black screen after upgrading failure:

Please try to enter into Calibration Mode: hold configuration button when press and release power button, after three seconds, release configuration button. You can also upgrade the firmware under this mode. But if you can not enter into calibration mode, please contact us.

13. Recover the footage due to power failure:

Power failure during shooting can damage the current footage, and footage can not be played back on camera or computer. For ProRes footage, please use the method below. Please make sure is operated on Windows and have Quicktime 7 installed. Download KineRecovery.zip to your PC, and then:

1. Copy files: unzip the file and copy KineRecovery.exe and QTCF.dll to the folder of footage, like PRJ-0002-003-A2_5D8A;
2. Run: run the KineRecovery.exe to start the recovery;
3. Complete: the recovered mov file will be generated in the footage folder, name starting with "r" .

5. TECH & SPEC AND CONNECTORS

5.1 Tech Parameters

5.1.1 MAVO LF SPEC

The following are typical settings, for latest complete list, please refer to SPEC of MAVO LF on the website.

Camera Type	Large Format Digital Cinema Camera			
Imaging Sensor	6K 3:2 -S35 Format CMOS		Size: 36x24mm	
Lens Mount	Native KineMOUNT as omni mount to be PL/EF/SONY E by solid mounting adapters		*PL, PL e-ND *EF, EF e-ND, EF Enhancer *Sony E	
ISO	Dual Base ISO		Max	
	5120(from 1600)	800(below 1600)	20480	
Dynamic Range	>14 stops			
Full Frame	FF 6K Wide	6016x2520, 0.2~75fps		Active size: 36x15.2mm, ø 39.1mm
	FF 6K	6016x3172, 0.2~50fps		Active size: 36x19.1mm, ø 41.0mm
	FF 3:2, Open Gate	6016x4016, 0.2~40fps		Active size: 36x24mm, ø 43.3mm
	FF 4:3 Ana	5376x4016, 0.2~40fps		Active size: 32x24mm, ø 40.0mm
	FF 6:5 Ana	4864x4016, 0.2~40fps		Active size: 29x24mm, ø 37.7mm
S35	S35 4K Wide	4096x1600, 0.2~100fps		Active size: 24.5x9.6mm, ø 26.3mm
	S35 4K	4096x2160, 0.2~75fps		Active size: 24.5x12.9mm, ø 27.7mm
	S35 5K Wide	5120x2160, 0.2~80fps		Active size: 30.5x12.9mm, ø 33.2mm
	S35 5K	5120x2704, 0.2~60fps		Active size: 30.5x16.2mm, ø 34.6mm
	S35 4:3 Ana	4096x3072, 0.2~50fps		Active size: 24.4x18.3mm, ø 30.6mm
	S35 1:1 Ana	3072x3072, 0.2~50fps		Active size: 18.3x18.3mm, ø 25.9mm
Other Cropping	3K Wide	3072x1200, 0.2~150fps		
	3K	3072x1620, 0.2~100fps		
	2K HD Wide	2048x860, 0.2~200fps		
	2K HD	2048x1080, 0.2~150fps		
Record Format	Codec Type	Codec Format	Bit Depth	
	Compressed cDNG	cDNG(.dng)	12bits	3:1/5:1/7:1
	Compressed KineRAW 2.0	KineRAW(.krw)	12bits	2:1-10:1, *release in 2019
	ProRes422HQ/422/422LT/Proxy	ProRes(.mov)	10bits	
	ProRes4444	ProRes(.mov)	12bits	up to 6K 30fps
	ProRes4444XQ	ProRes(.mov)	12bits	up to 4K HD 48fps

(Continued from the technical data sheet on the previous page)

Shutter Angle	0.7°~358° Rolling Shutter			
Monitoring	Video Port x2	HD Port x1	SDI x2*	*Applicable on KineBACK-W
Sync Function	Tally, AutoSlate, Beeper, Trigger, SMPTE LTC*, 3D/Multi-cam Sync*			*Applicable on KineBACK-W
LUT	Preset: Neutral , Support Custom 3D LUT			
Audio Capture	In-camera MIC; 3.5mm MIC-in; KineAudio* with 48V Phantom Power XLR			*Applicable on KineBACK-W
Record Media	2.5" SSD with 7mm Height			
Power	Power in	Consumption		
	DC IN 11~19V/SideGrip/V-Mount*	23W		*Applicable on KineBACK-W
Body Color	Titanium Grey			
Weight	2.1 lb/990g			*Only Body
Size	4.5x4.3x3.7" / 115x110x95 mm			*W/o projections, WxHxL
Operating Temp	0 ~ 40°C			

All specifications shown are preliminary and ject to change without notice.

5.1.2 MAVO LF Frame Rate and FPS

The following chart contains resolution, frame rate and codecs:

Image Format	Format	Resolution	Max FPS	Codec
FF	6K Wide	6016x2520	75	ProRes or RAW
	6K DCI	6016x3172	50	ProRes or RAW
	6K HD Wide	5760x2400	75	ProRes or RAW
	6K HD	5760x3240	50	ProRes or RAW
	6K Open Gate	6016x4016	40	ProRes or RAW
	4:3 Anamorphic	5376x4016	40	ProRes or RAW
	6:5 Anamorphic	4864x4016	40	ProRes or RAW
	4K HD Wide (Oversample)	3840x1600	75	ProRes
	4K HD (Oversample)	3840x2160	50	ProRes
	3K HD Wide (Oversample)	2944x1227	75	ProRes
3K HD (Oversample)	2944x1620	50	ProRes	
S35	5K Wide	5120x2160	80	ProRes or RAW
	5K DCI	5120x2704	60	ProRes or RAW
	4:3 S35 变宽	4096x3072	50	ProRes or RAW
	1:1 S35 变宽	3072x3072	50	ProRes or RAW
	4K Wide	4096x1720	100	ProRes or RAW
	4K	4096x2160	75	ProRes or RAW
	4K HD Wide	3840x1600	100	ProRes or RAW
4K HD	3840x2160	75	ProRes or RAW	
M43	3K Wide	3072x1280	150	ProRes or RAW
	3K	3072x1620	100	ProRes or RAW
	3K HD Wide	2944x1227	150	ProRes or RAW
	3K HD	2944x1620	100	ProRes or RAW
S16	2K Wide	2048x860	200	ProRes or RAW
	2K	2048x1080	150	ProRes or RAW
	2K HD Wide	1920x800	200	ProRes or RAW
	2K HD	1920x1080	150	ProRes or RAW

NOTE Oversampling/DownScale is only for ProRes. You can get images of higher resolution, less noise but high latitude.

NOTE You can define FPS to any value between minimum fps (0.2fps, in current firmware) and the maximum sensor fps of current resolution. Accuracy can be 0.001fps.

NOTE Due to the technical limitation of SSDport, ProRes4444XQ is up to 4K 48fps; ProRes4444 is up to 6K 30fps.

5.2 Connectors

This chapter will introduce specification and pin-out of some connector/ports on KineBACK-W including DC IN, CTRL, EXT and TC.

5.2.1 DC IN

DC IN is on the lower right of camera body, a 1B 2-pin Lemo socket. The voltage range for camera is 11V~19V, DO NOT use power source higher than 19V, or the camera will be burned. Also please note that:

- Max current of external power is 3A;
- Max consumption of camera body only is 25W;
- With KineMON, max consumption is 30W.

NOTE Oversampling/DownScale Red dot and groove on the socket shall match pin 1.

5.2.2 CTRL

CTRL is on the lower front of the camera body, a 0B 4-pin Lemo socket.

- Short pin 1 and pin 3 can trigger on/off;
- Pin 2 can output 3.3V, max 1A. Pin 2 and 3 can be used for power supply;
- Pin 4 is reserved.

CAUTION The camera will shut down if Pin 2 outputs a higher current than 1A; camera also can NOT be powered on under such high current.



1. DC IN as VDD
2. Ground

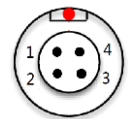

1. REC;
2. 3.3V output;
3. GND;
4. Reserved

5.2.3 EXT

EXT port is on KineBACK-W, a 1B 6-pin Lemo socket. It can output 12V, max current 1A, or even output power from V-lock battery plate when a battery is attached. Meanwhile, EXT also transmits signal to control the Movcam motor for follow-focus.

CAUTION The camera will shut down if Pin 2 or Pin 5 outputs a higher current than 1A; camera also can NOT be powered on under such high current.

NOTE CAN_L and CAN_H are for the control of Movcam motor.

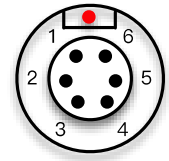

1. Detect
2. CAN_L
3. CAN_H
4. 12V output
5. Battery output
6. GND

5.2.4 TC

TC port is on KineBACK-W, a 0B 5-pin Lemo socket for timecode in or out. For different timecode generators, such as Ambient timecode generator Nano Lockit, or SoundDevice recorder which has TC system, the physical spec and definition is the same.

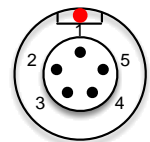

1. GND
2. LTC IN
- 3,4. NC
5. LTC OUT

5.3 Mechanical Drawings

5.3.1 Physical Parameters for Body with KineMount

Front View of Body with KineMount

Dimensions are shown in mm.

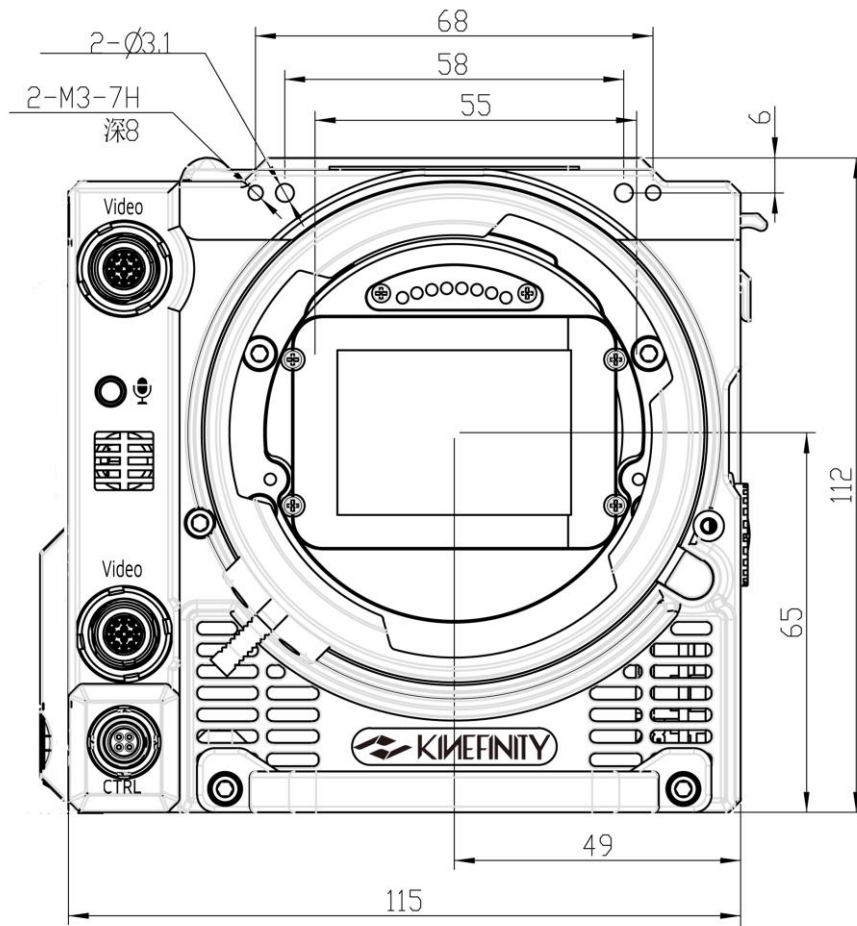

Front View of Body with KineMount (with SideGrip)

Dimensions are shown in mm.

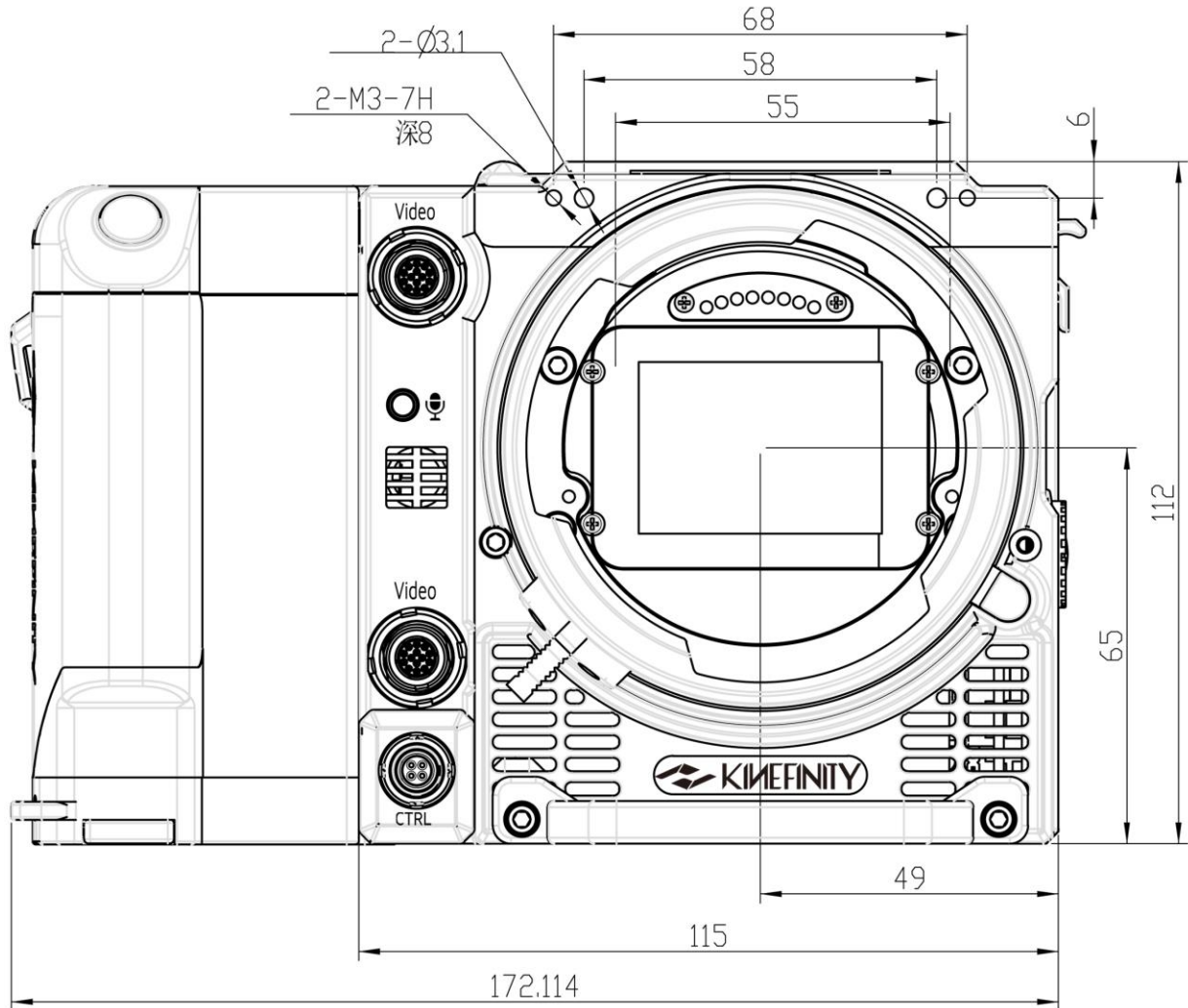

Top View of Body with KineMount

Dimensions are shown in mm.

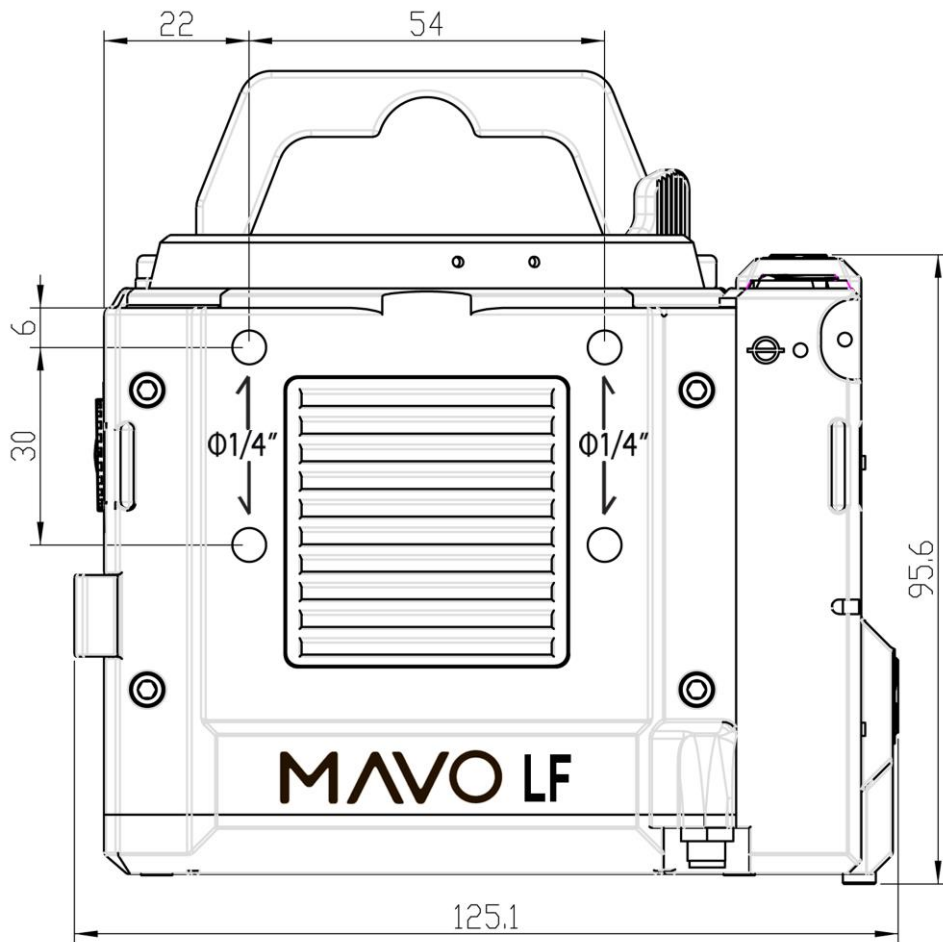

Bottom View of Body with KineMount

Dimensions are shown in mm.

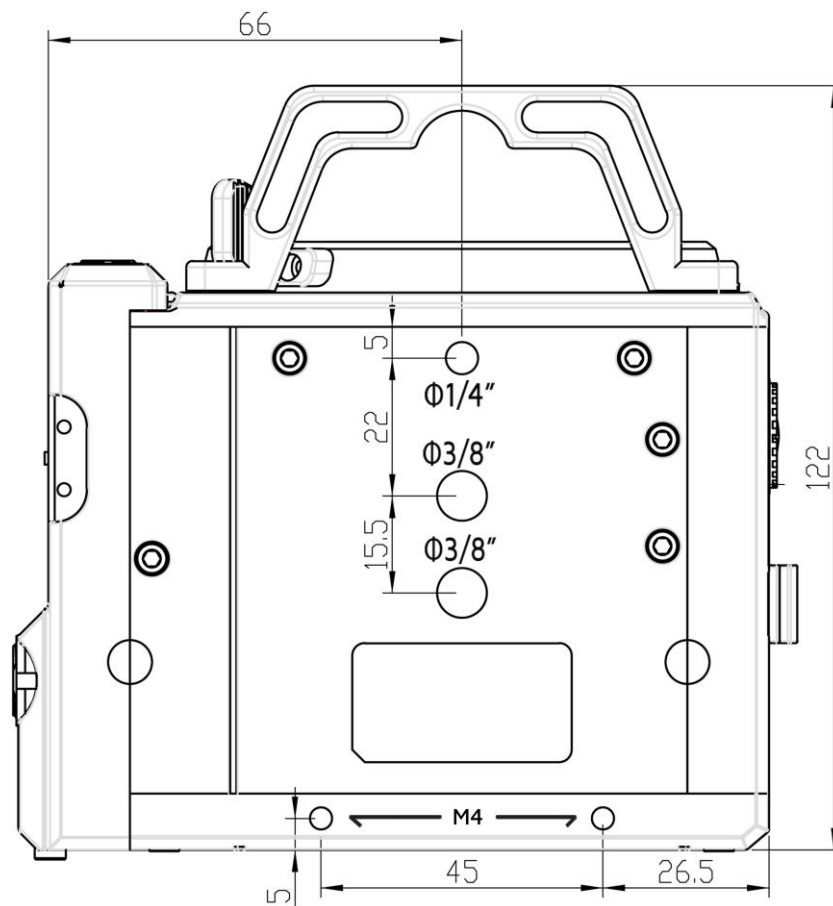

5.3.2 Body with KineMOUNT and EF Mounting Adapter (with KineBACK-W)

Front View of Body with KineMOUNT and EF Mounting Adapter (with KineBACK-W)

Dimensions are shown in mm.

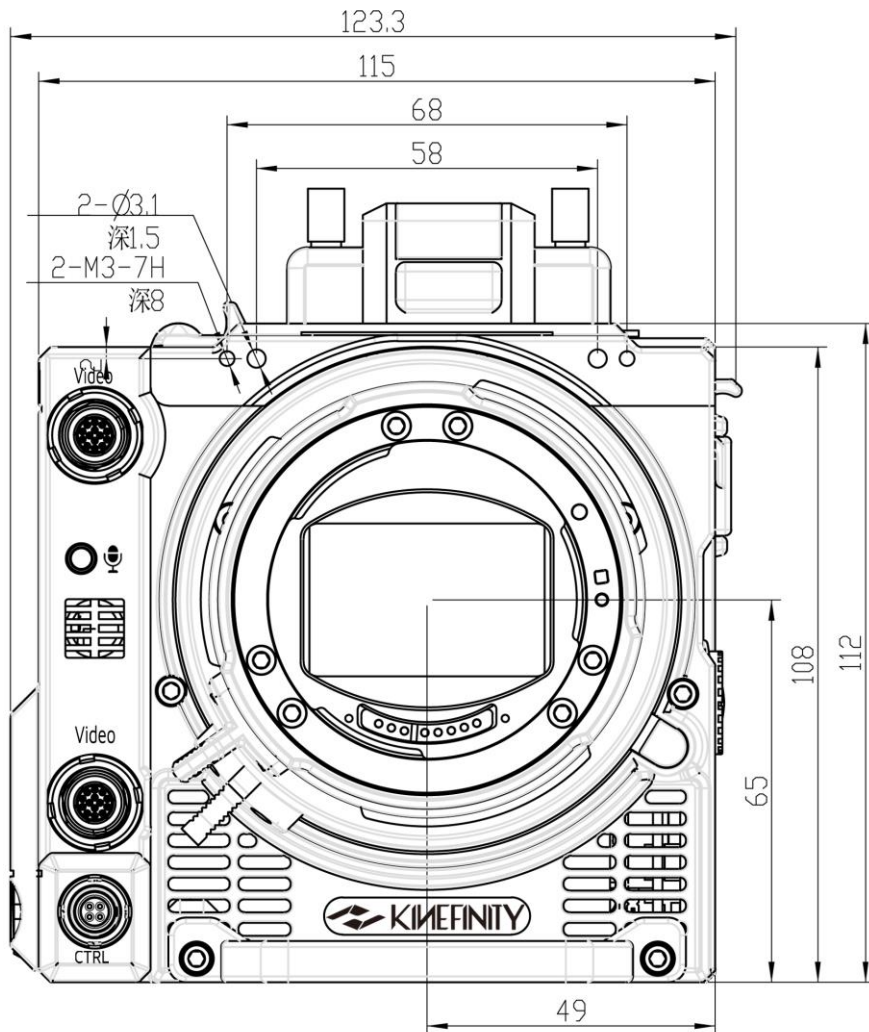

Top View of Body with KineMOUNT and EF Mounting Adapter (with KineBACK-W)

Dimensions are shown in mm.

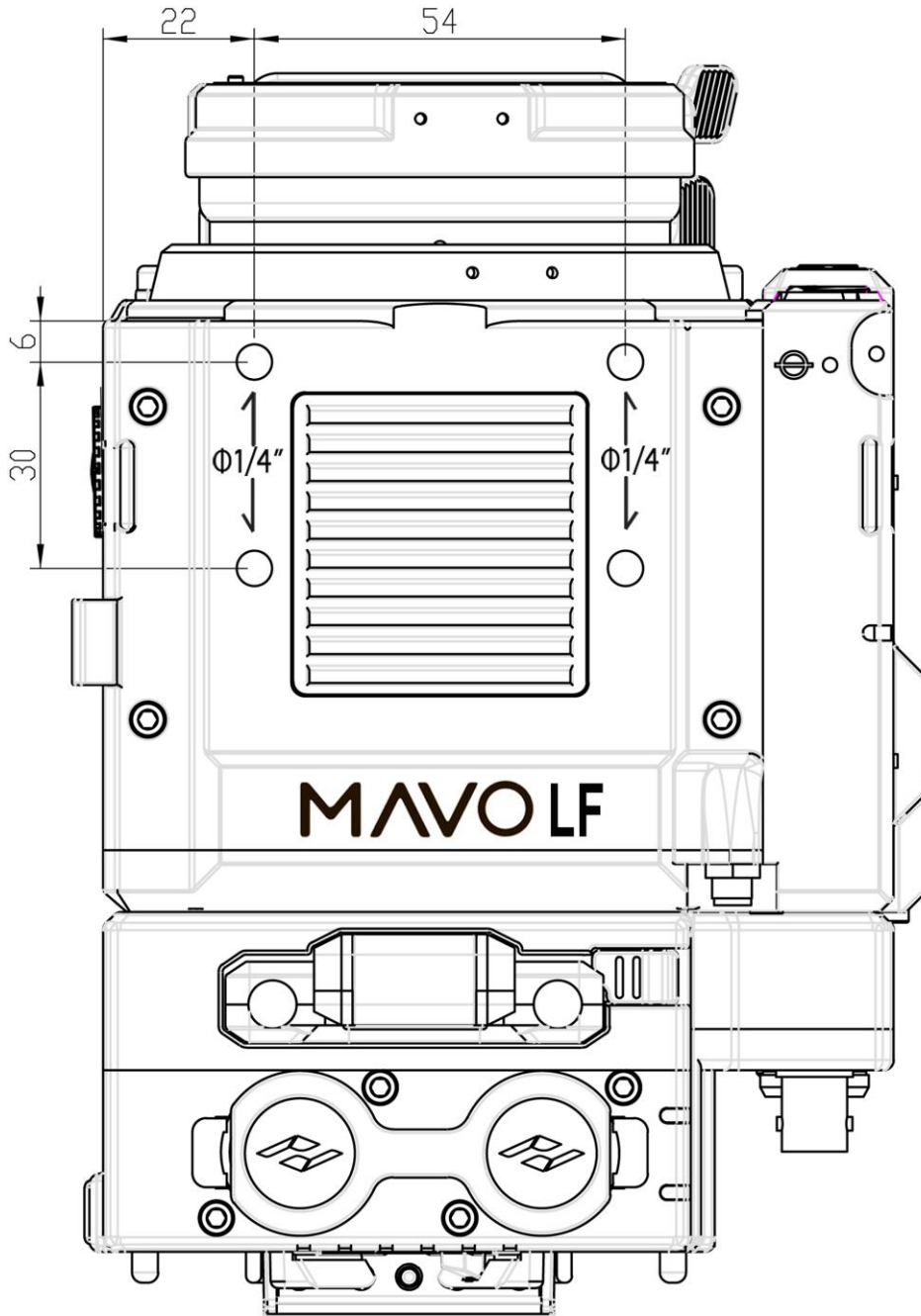

5.3.3 Body with KineMOUNT and E Mounting Adapter (with KineBACK-W)

Front View of Body with KineMOUNT and E Mounting Adapter (with KineBACK-W)

Dimensions are shown in mm.

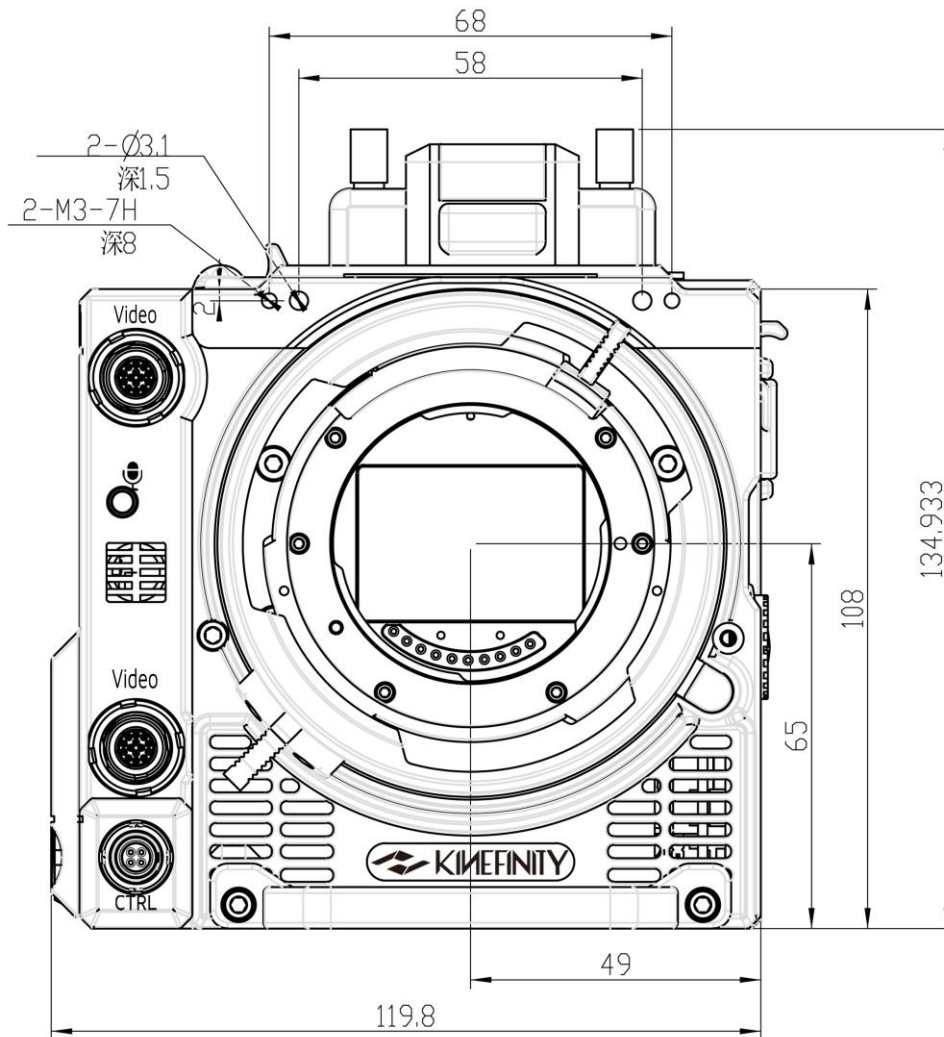

Top View of Body with KineMOUNT and E Mounting Adapter (with KineBACK-W)

Dimensions are shown in mm.

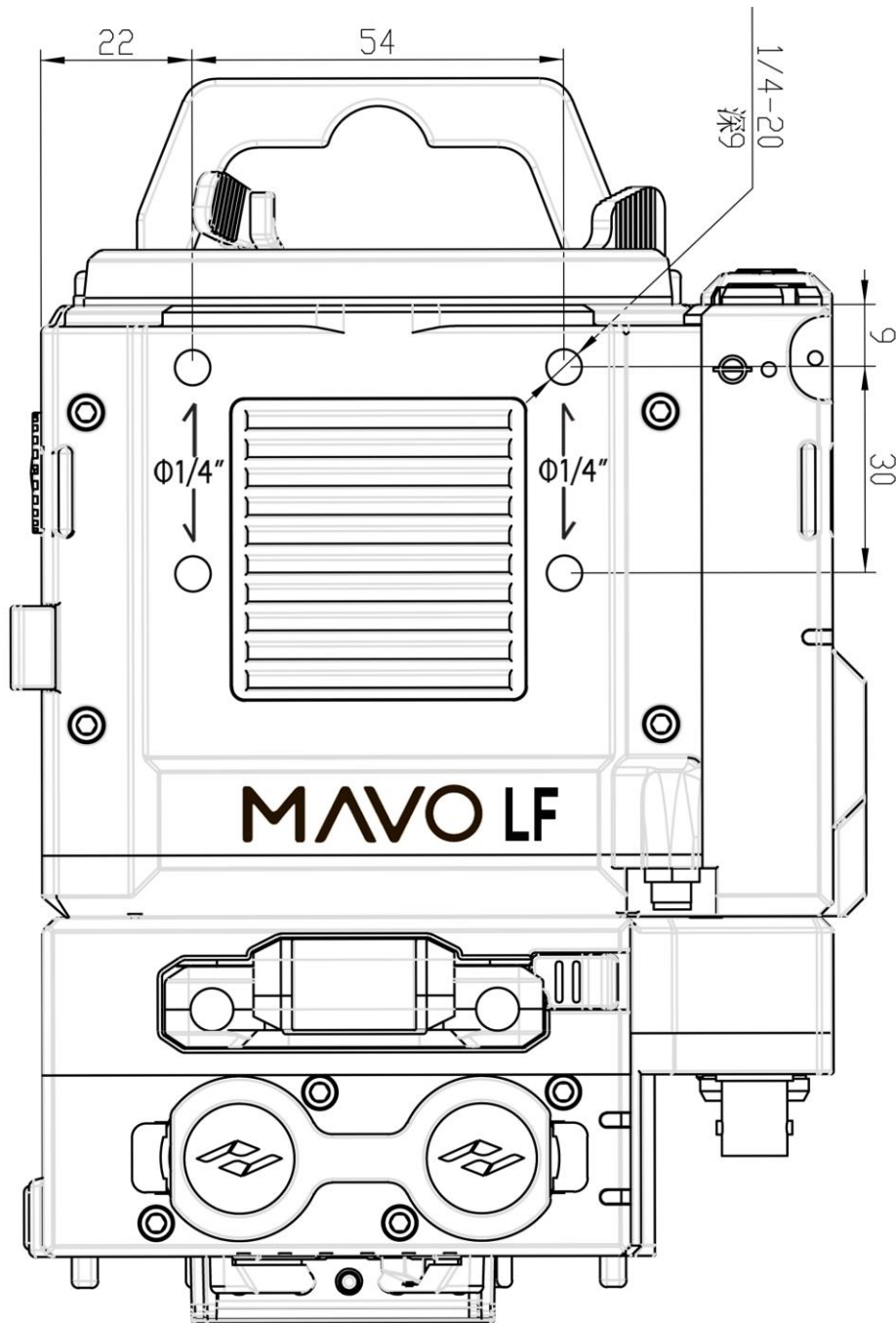

Bottom View of Body with KineMOUNT and E Mounting Adapter (with KineBACK-W)

Dimensions are shown in mm.

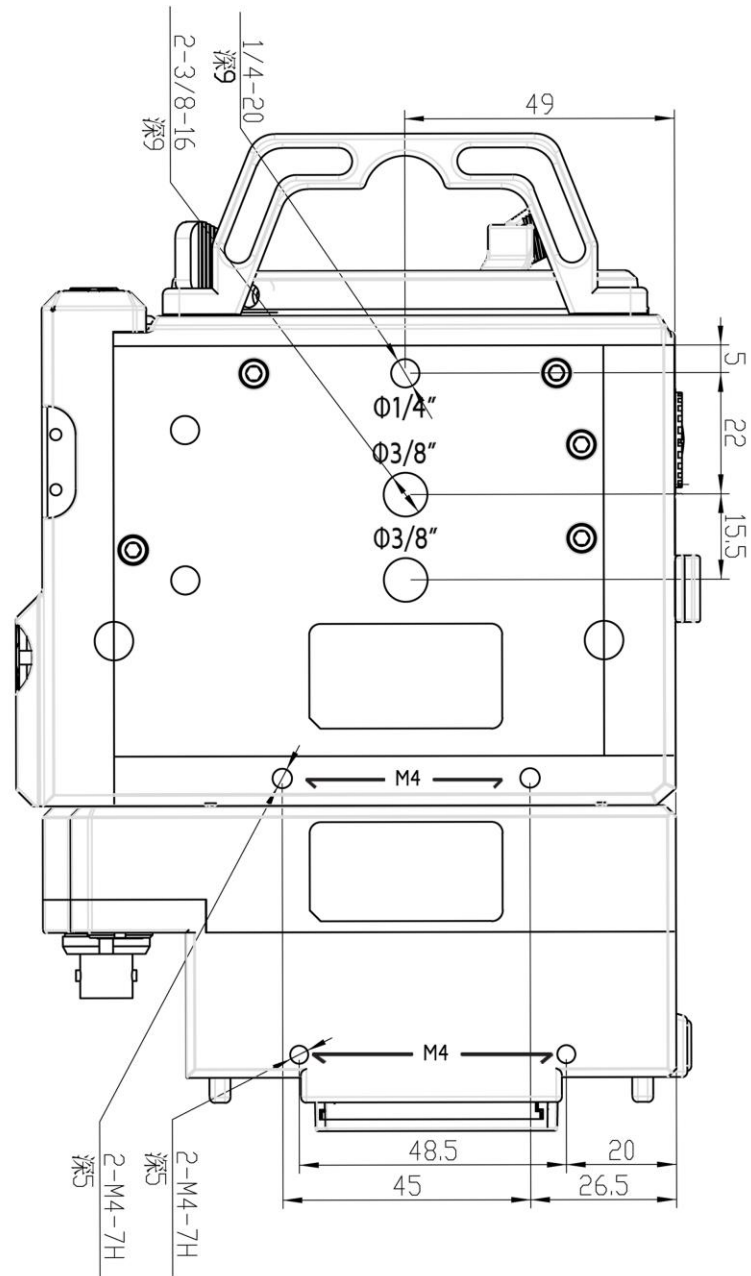

5.3.4 Body with KineMOUNT and PL Mounting Adapter (with KineBACK-W)

Front View of Body with KineMOUNT and PL Mounting Adapter (with KineBACK-W)

Dimensions are shown in mm.

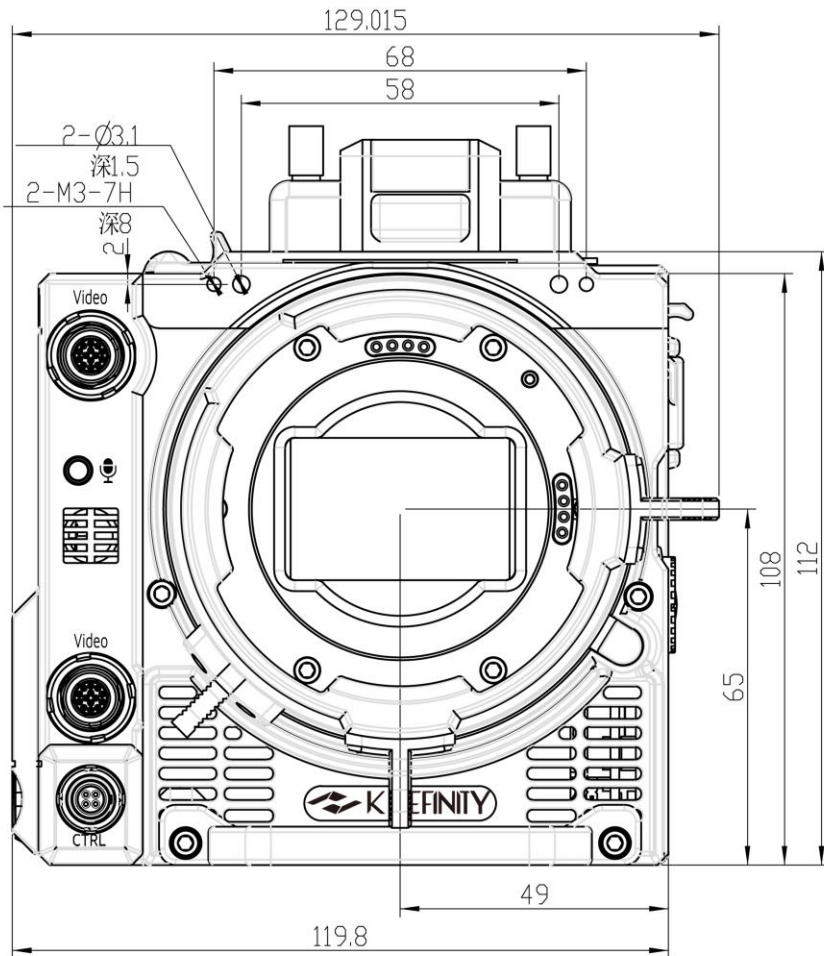

Top View of Body with KineMOUNT and PL Mounting Adapter (with KineBACK-W)

Dimensions are shown in mm.

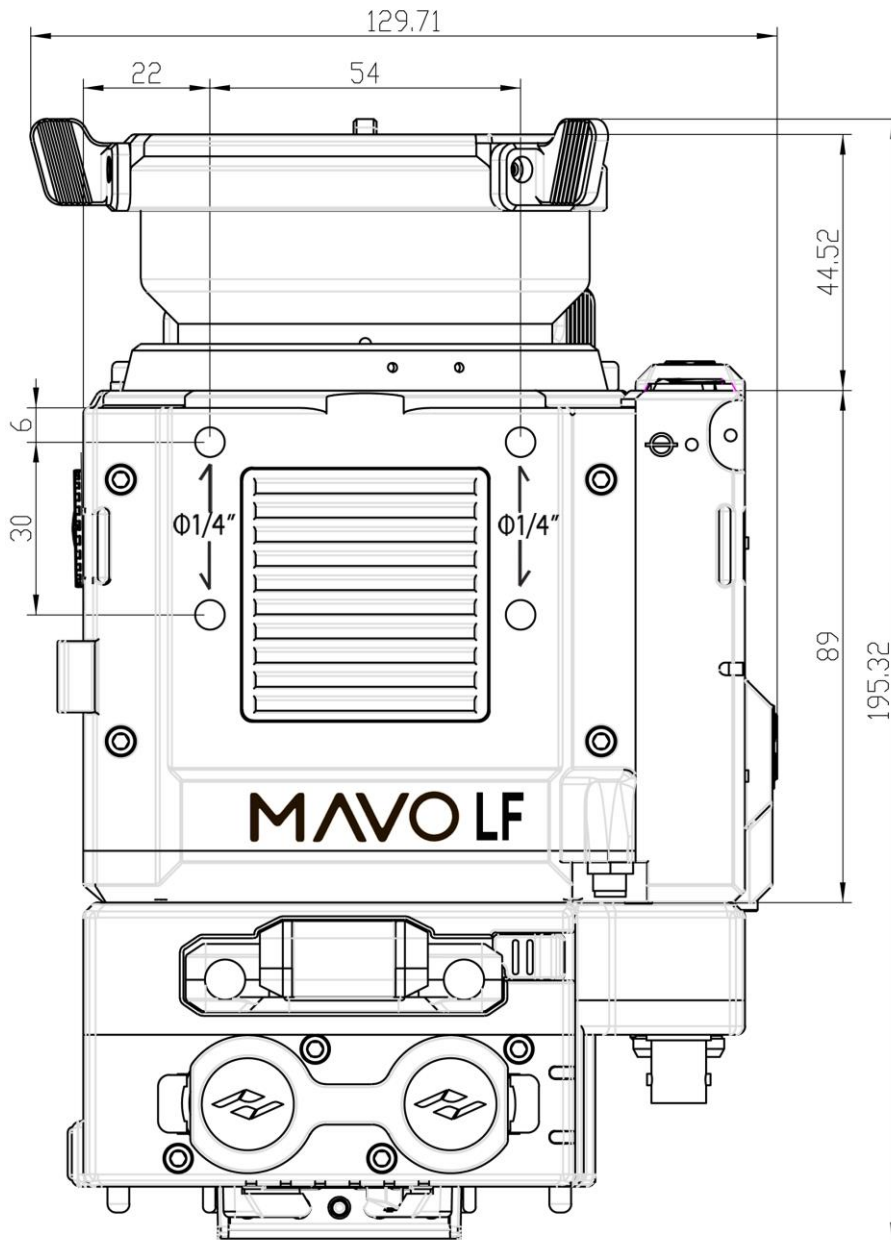

Bottom View of Body with KineMOUNT and PL Mounting Adapter (with KineBACK-W)

Dimensions are shown in mm.

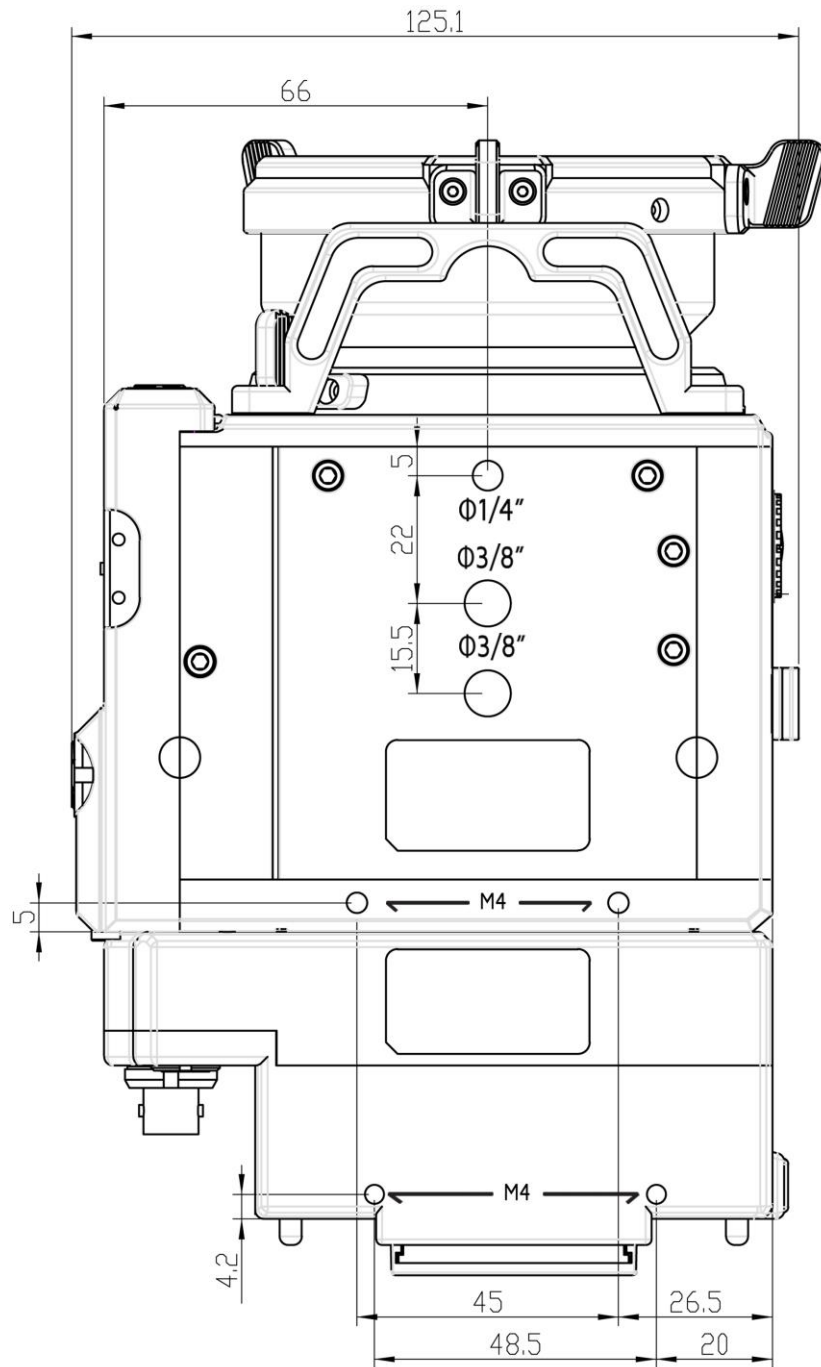

Back View

Dimensions are shown in mm.

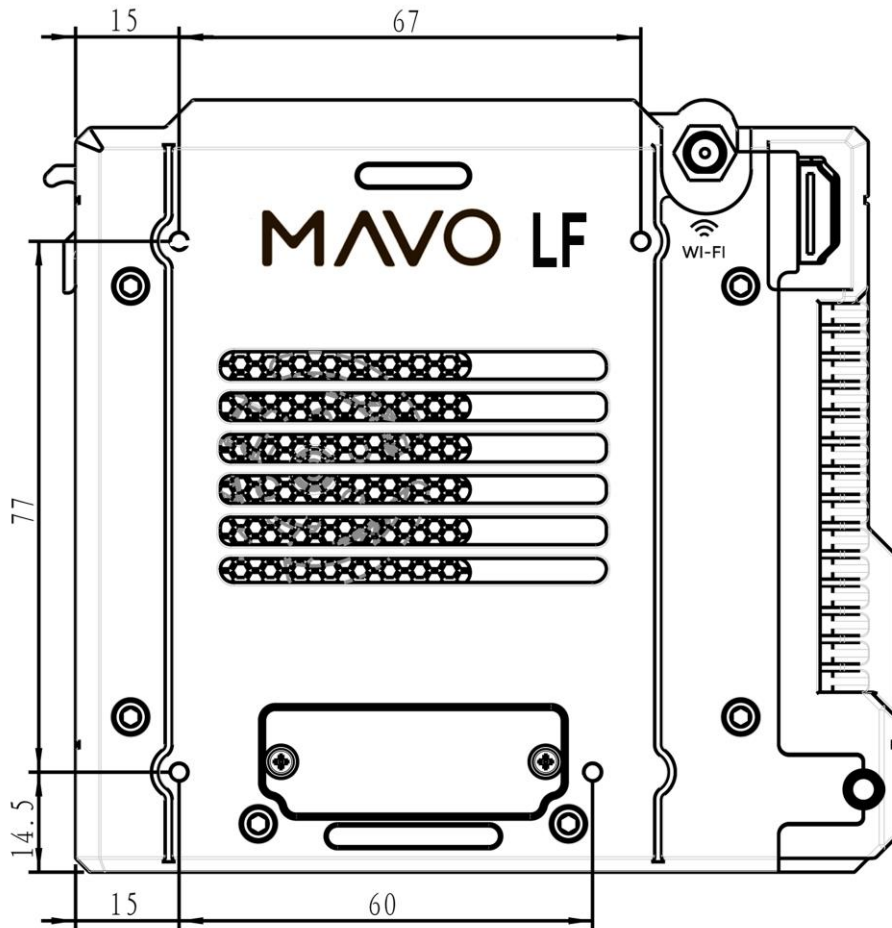

**Kinefinity Inc.**

www.kinefinity.com

Address: Bldg #1, Enji West Park, No.1, Fuwailiangjiadian, Haidian
District Beijing, 100142, China

Phone: 0086-10-51243411

Email: support@kinefinity.com, sales@kinefinity.com



Copyright 2019 Kinefinity Inc.

ALL SPECIFICATIONS SHOWN ARE PRELIMINARY AND JECT TO CHANGE WITHOUT NOTICE.

KineMAX™, KineMAG™, KineKIT™ are trademarks of Kinefinity™.