

**PMW-100**  
Solid-State Memory Camcorder

**SONY**  
make.believe

**XDCAM HD**

**MPEG HD422**



**XDCAM** **MPEG HD422** **DVCAM** **SXS** **Exmor**

## High-quality XDCAM™ HD422 Handheld Camcorder

The PMW-100 is a compact and lightweight camcorder with a new 1/2.9-inch type Exmor™ CMOS sensor. With its high-quality MPEG HD422 (50 Mbps) recording capability, which is widely accepted in broadcasting stations and production houses, the PMW-100 can contribute to your creativity in many different applications, including news gathering and documentary production.

### Compact Design

#### » Handheld Camcorder for Professional Use

The PMW-100 is a compact and lightweight camcorder with abundant features for the professional user. Its ergonomic design gives more shooting opportunities from a variety of angles. And it can be used as an ideal companion camera with the PMW-500 XDCAM HD422 memory camcorder.



### Camera Features

#### » High Sensitivity

The PMW-100 incorporates a 1/2.9-type Full HD Exmor CMOS sensor (1920 x 1080) to achieve high resolution, high sensitivity, low noise, and wide dynamic range. These capabilities are essential to the professional when shooting under severe lighting conditions.

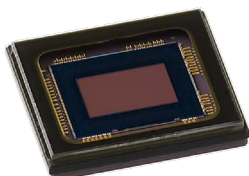

**Exmor**

#### » Manual Control of Lens

The PMW-100 incorporates 5.4 - 54 mm (equivalent to 40 - 400 mm on 35 mm lens) zoom lenses with an Optical SteadyShot™ feature, and – to expand its applications – an optional VCL-HG0737K lens (a 0.7x wide conversion lens). Zoom and focus can be manually controlled with the Lens Control Ring, which includes a selector switch to set the ring for focus or zoom control. There is also an Exposure Control Dial for manual adjustment of camera brightness.



#### » 3.5-inch WVGA (852x480) LCD Monitor

The PMW-100 is equipped with a large, easy-to-read, 3.5-inch WVGA color LCD panel, which assists with critical focus control during HD shooting.



#### » Focus Assist Functions

Various functions are provided to help with precise control of focus. These include Color Peaking, MF (Manual Focus) Assist, One-push Auto Focus, Expanded Focus, and the Auto Focus function.

## » Slow & Quick Motion (Visual Effects)

By changing the frame rate, slow- and fast-motion visual effects (Slow & Quick Motion) are available. Other visual effects include Interval Recording, Frame Recording, and Slow Shutter.

## » NightShot Function

The PMW-100 offers a NightShot function, which adopts a built-in Infrared LED. This function helps users to shoot in extremely low light environments without any light sources.

## » Picture Profile

The Picture Profile feature allows you to easily call up customized picture-tonal settings to suit particular shooting conditions, rather than having to readjust the camera each time. Picture Profile data can be saved on SxS™ memory cards, and shared with multiple PMW-100 units.

## » Selectable Gamma Curves

You can select the best-suited preset gamma curve to handle contrast and give a specific 'look' to an image. There are six types of standard gamma curve, and four types of HyperGamma which are identical to those on CineAlta™ cameras.

### Recording Section

## » MXF and FAT File Format

The PMW-100 can be used as a Handheld camcorder for various types of file-based operation because it employs both industry-standard file formats: the MXF file format (UDF) and MP4 file format (FAT).

## » MPEG HD422 Codec

You can record Full HD video (1920x1080) at up to 50 Mbps using MPEG HD422 compression technology, and enjoy the benefits of proven, high-speed, and intuitive XDCAM HD422 workflow. With the PMW-100, you can also record video in MPEG HD or DVCAM™ format. (Note: Proxy video is not available with the PMW-100.)

**XDCAM**

## » 4-hour Continuous Recording

By combining the BP-U60 with two optional SBS-64G1A SxS Memory Cards (64-GB SxS-1 cards), you can record continuously for up to four hours. With the high-capacity Lithium-Ion battery BP-U90, you can achieve six hours of continuous operation.

## » Cache Recording

Once activated, the PMW-100 continuously streams audio and video into its internal memory. When you push the REC START button, the content buffered in the camcorder's memory is recorded onto the memory media at the start of the recording clip. The caching period can be set at up to 15 seconds. This function is useful when shooting a developing situation, such as in news gathering, so as not to miss a critical moment.

## » Continuous Recording

By activating the Continuous Recording function, multiple clips can be recorded as a single clip, which makes it easy to ingest the file to a Non Linear Editing (NLE) system.

## » Reliable, High-speed Recording Media

The XDCAM Series uses high-speed SxS PRO™ and SxS-1 memory cards for its recording media, developed specifically for professional content creation applications. These memory cards boast high-speed data transfer, which accelerates the post-production workflow. SxS memory cards are also resistant to shock and vibration. Furthermore, Memory Stick media, SD cards, and XQD cards can be used as emergency backup media with the appropriate adaptors.



**SxS**

## Audio

### » High-quality Audio

The PMW-100 is equipped with two XLR connectors, which are for professional microphones such as the ECM-MS2/680S/678/673 and wireless microphone systems such as the UWP-V1/V2. By combining the built-in stereo microphone with external microphone input, you can record up to four channels of 24-bit 48-kHz high-quality audio in MPEG HD422 50-Mbps mode.

## Interfaces

### » HD/SD-SDI, HDMI, and i.LINK

The SDI connector allows the camcorder to interface with other professional products, and supports down-conversion from HD to SD signals. A domestic-use TV can be used as a monitor with the HDMI connector. The i.LINK™ connector can be used for HDV when SP 1440 (FAT) mode is selected, and for DV when DVCAM (FAT) mode is selected.

### » Timecode IN/OUT, and Genlock

The PMW-100 comes equipped with Timecode Input/Output and Genlock Input connectors. These allow you to synchronize the timecode and video with other cameras, enabling easier multi-camera productions.

### » USB2.0 (Device)

The PMW-100 can be connected directly with a PC using the USB interface. Even without a memory card reader/writer, you can easily ingest shot files from the PMW-100 to PC.

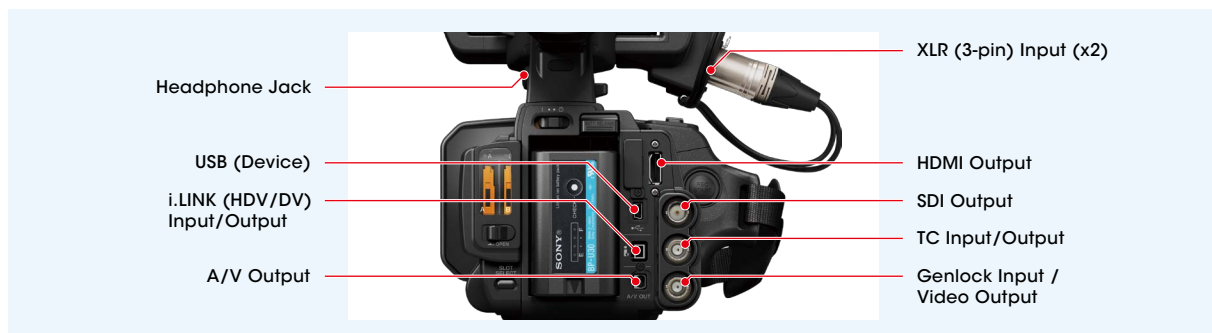
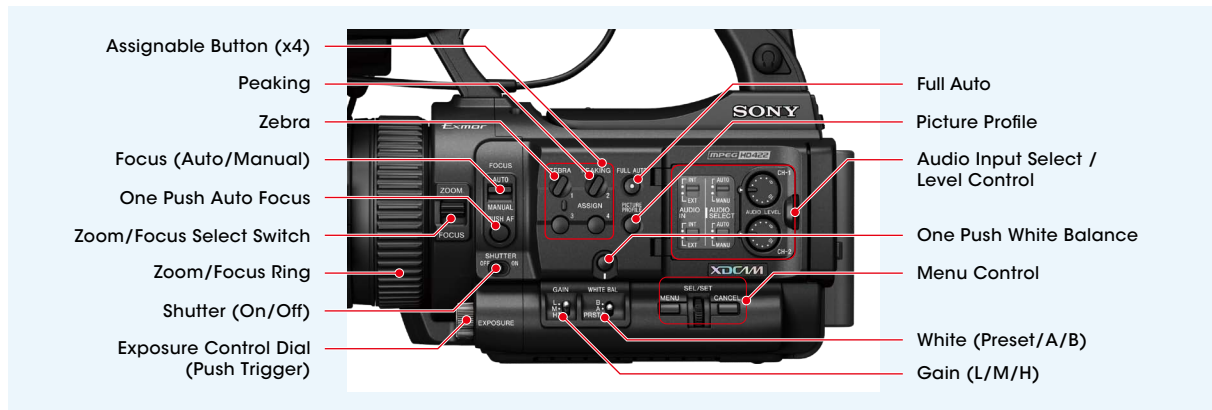

## XDCAM HD422 Workflow

### XDCAM HD422 System

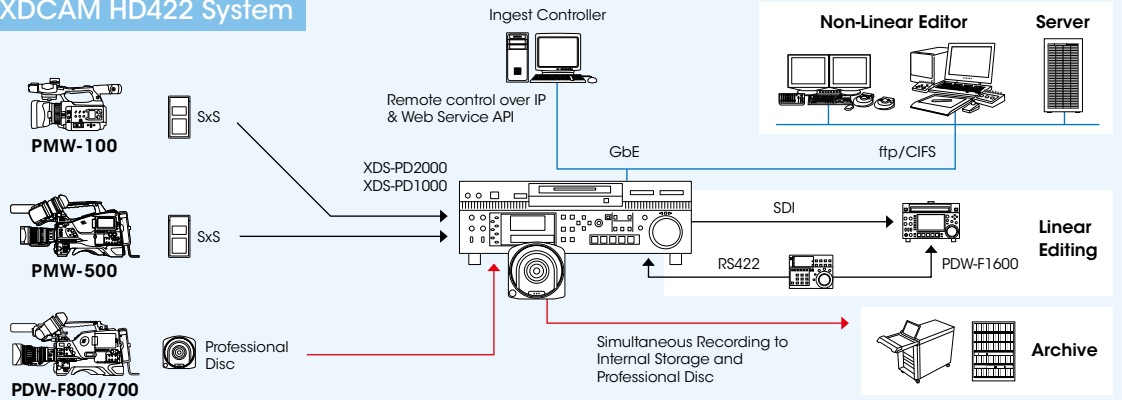

### Ingest to PC

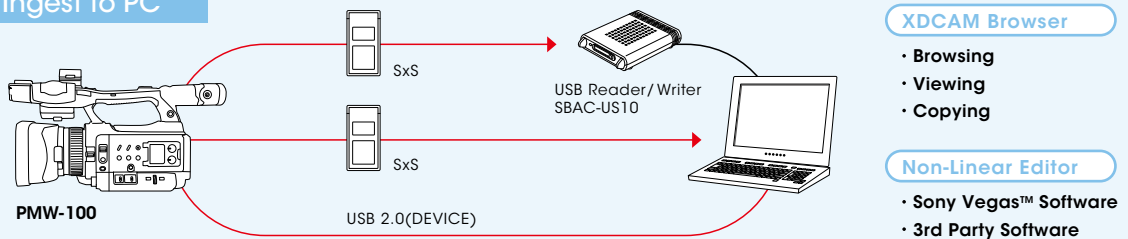

## Optional Accessories for PMW-100

 <p><b>SBP-64A/32</b> SxS Pro Memory Card</p>	 <p><b>SBS-64G1A / SBS-32G1A</b> SxS-1 Memory Card</p>	 <p><b>MEAD-MS01</b> Memory Stick Adaptor</p>	 <p><b>MEAD-SD01</b> SD Card Adaptor</p>	 <p><b>QDA-EX1</b> XQD Adaptor</p>	 <p><b>SBAC-US10</b> SxS Memory USB Reader/Writer</p>
 <p><b>BP-U90/U60/U30</b> Li-Ion Battery Pack</p>	 <p><b>BC-U1</b> Battery Charger (1-slot)</p>	 <p><b>BC-U2</b> Battery Charger (2-slot)</p>	 <p><b>ECM-680S</b> Stereo Microphone</p>	 <p><b>ECM-MS2</b> Stereo Microphone</p>	 <p><b>ECM-678/673</b> Monaural Microphone</p>
 <p><b>UWP-V1/V2</b> Wireless Microphone System</p>	 <p><b>VCL-HG0737K</b> Wide Conversion Lens</p>	 <p><b>HVR-MRC1K</b> Memory Recording Unit</p>	 <p><b>PHU-220R</b> Professional Harddisk Unit</p>		

\*The photos show the BP-U90, the ECM-678, and the UWP-V1 respectively.

## SPECIFICATIONS

General	
Mass	Approx. 1.5 kg (Approx. 3 lb 5 oz) (body) Approx. 1.8 kg (Approx. 3 lb 15 oz) (with lens hood, eye piece, BP-U30 battery, a SxS memory card)
Dimensions (W x H x D)	167 x 164 x 278 mm (6 5/8 x 6 1/2 x 11 inches) (without protrusions)
Power Requirements	DC 12 V
Power Consumption	Approx. 12 W (while recording, EVF On, LCD monitor Off, I/O Select Off) Approx. 14 W (while recording, EVF On, LCD monitor On, I/O Select HD SDI & HD HDMI)
Operating Temperature	0°C to 40°C (32°F to 104°F)
Storage Temperature	-20°C to +60°C (-4°F to +140°F)
Battery Operating Time	Approx. 2 hrs with BP-U30 battery (while recording, HQ 1920 59.94i Mode, EVF On, LCD monitor Off, I/O Select Off) Approx. 4 hrs with BP-U60 battery (while recording, HQ 1920 59.94i Mode, EVF On, LCD monitor Off, I/O Select Off) Approx. 6 hrs with BP-U90 (while recording, HQ 1920 59.94i Mode, EVF On, LCD monitor Off, I/O Select Off)
Recording Format (Video)	<UDF> - HD422 Mode: CBR, maximum bit rate: 50 Mbps, MPEG-2 422P@HL - HD420 Mode: VBR, 35 Mbps, MPEG-2 MP@HL - DVCAM Mode: DVCAM <FAT> - HQ 1920 Mode: VBR, 35 Mbps, MPEG-2 MP@HL - HQ 1440 Mode: VBR, 35 Mbps, MPEG-2 MP@HL - SP 1440 Mode: CBR, 25 Mbps, MPEG-2 MP@H-14 - DVCAM Mode: DVCAM
Recording Format (Audio)	<UDF> - HD422 Mode: LPCM 24 bits, 48 kHz, 4 channels - Other Mode: LPCM 16 bits, 48 kHz, 4 channels <FAT> - HD Mode: LPCM 16 bits, 48 kHz, 4 channels - SD Mode: LPCM 16 bits, 48 kHz, 2 channels
Recording Frame Rate	<UDF> HD422 Mode: MPEG-2 422P@HL, 50Mbps / CBR - 1920x1080 / 59.94i, 50i, 29.97p, 25p, 23.98p - 1280x720 / 59.94p, 50p, 29.97p, 25p, 23.98p HD420 Mode: MPEG-2 MP@HL, 35Mbps / VBR - 1440x1080 / 59.94i, 50i, 29.97p, 25p, 23.98p - 1280x720 / 59.94p, 50p, 29.97p, 25p, 23.98p DVCAM Mode: - 720x480 / 59.94i, 29.97PsF - 720x576 / 50i, 25PsF <FAT> HQ 1920 Mode: MPEG-2 MP@HL, 35Mbps / VBR - 1920x1080 / 59.94i, 50i, 29.97p, 25p, 23.98p HQ 1440 Mode: MPEG-2 MP@HL, 35Mbps / VBR - 1440x1080 / 59.94i, 50i, 29.97p, 25p, 23.98p HQ 1280 Mode: MPEG-2 MP@HL, 35Mbps / VBR - 1280x720 / 59.94p, 50p, 29.97p, 25p, 23.98p SP 1440 Mode: MPEG-2 MP@H-14, 25Mbps / CBR - 1440x1080 / 59.94i, 50i, 23.98p (2-3 pull down) DVCAM Mode: - 720x480 / 59.94i, 29.97PsF - 720x576 / 50i, 25PsF
Recording/Playback Time	<UDF> HD 422 Mode: Approx. 120 min with SBP-64 / SBS-64G1A (64 GB) memory card Approx. 60 min with SBP-32 / SBS-32G1A (32 GB) memory card Approx. 30 min with SBP-16 (16 GB) memory card HD 420 Mode: Approx. 180 min with SBP-64 / SBS-64G1A (64 GB) memory card Approx. 90 min with SBP-32 / SBS-32G1A (32 GB) memory card Approx. 45 min with SBP-16 (16 GB) memory card DVCAM Mode: Approx. 220 min with SBP-64 / SBS-64G1A (64 GB) memory card Approx. 110 min with SBP-32 / SBS-32G1A (32 GB) memory card Approx. 55 min with SBP-16 (16 GB) memory card <FAT> HQ 1920/HQ 1440 Mode: Approx. 200 min with SBP-64 / SBS-64G1A (64 GB) memory card Approx. 100 min with SBP-32 / SBS-32G1A (32 GB) memory card Approx. 50 min with SBP-16 (16 GB) memory card SP 1440 Mode: Approx. 280 min with SBP-64 / SBS-64G1A (64 GB) memory card Approx. 140 min with SBP-32 / SBS-32G1A (32 GB) memory card Approx. 70 min with SBP-16 (16 GB) memory card

	DVCAM Mode Approx. 260 min with SBP-64 / SBS-64G1A (64 GB) memory card Approx. 130 min with SBP-32 / SBS-32G1A (32 GB) memory card Approx. 65 min with SBP-16 (16 GB) memory card
Lens	
Lens Mount	Fixed
Zoom Ratio	10x (optical), servo/manual
Focal Length	f = 5.4 - 54 mm (equivalent to 40-400 mm on 35 mm lens)
Iris	F1.8 - F2.9, auto/manual selectable
Focus	AF/MF selectable, 10 mm to ∞ (Wide), 800 mm to ∞ (Tele)
Image Stabilizer	ON/OFF selectable, shift lens
Filter Diameter	M37 mm, pitch 0.75mm
Camera Section	
Imaging Device (Type)	1/2.9-inch type Single-chip Exmor CMOS
Effective Picture Elements	1920 (H) x 1080 (V)
Minimum Illumination	0.40 lx (typical) (1920 x 1080/59.94i Mode, F1.8, +18 dB gain, with 64-frame accumulation, 100% video level) 0.08 lx (typical) (1920 x 1080/59.94i Mode, F1.8, +18 dB gain, with 64-frame accumulation, 50% video level)
Shutter Speed	1/32 sec to 1/2,000 sec
Slow Shutter (SLS)	2, 3, 4, 5, 6, 7, 8, 16, 32, and 64-frame accumulation
Slow & Quick Motion Function	720p: Frame rate selectable from 1 fps to 60 fps (from 1 fps to 50 fps in PAL area setting in UDF Mode) 1080p: Frame rate selectable from 1 fps to 30 fps (from 1 fps to 25 fps in PAL area setting in UDF Mode)
White Balance	Presef (3200K), Memory A, Memory B/ATW
Gain	-3, 0, 3, 6, 9, 12, 18 dB, AGC
Gamma Curve	Selectable
Input/Output	
Audio Input	XLR-type 3-pin (female) (x2), line/mic/mic +48 V selectable Line: +4dBu Mic: -30dBu-70dBu
Composite Output	AV multi connector, NTSC or PAL
Video Output	BNC (x1), HD-Y/Composite 1.0Vp-p, 75Ω (switchable to Genlock in)
Audio Output	A/V multi connector -10dBu (Reference Level), 47kΩ
SDI Output	BNC (x1), HD/SD selectable SMPTE 292M/259M standards
i.LINK	IEEE 1394, 4-pin (x1), HDV (HDV 1080i) / DV input/output, S400
Timecode Input	BNC (x1) (switchable to TC out) SMPTE 12M-2-2008 standard 0.5V-1.8Vp-p, 10kΩ
Timecode Output	BNC (x1) (switchable to TC in) SMPTE 12M-2-2008 standard 1.0Vp-p, 10kΩ
Genlock Input	BNC (x1) (switchable to Video out) 1.0 Vp-p, 75Ω
USB	USB device, mini-B (x1)
Headphone Output	Stereo mini jack (x1), -18dBu 16Ω
Speaker Output	Monaural, 250mW
DC Input	DC jack
HDMI Output	Type A (x1)
Monitoring	
Viewfinder	0.24-inch type color LCD: 392 (H) x 224 (V), 16:9
Built-in LCD Monitor	3.5-inch type color LCD monitor: 852 (H) x 3 (RGB) x 480 (V), 16:9
Built-in Microphone	
Built-in Microphone	Omni-directional stereo electret condenser microphone
Media	
Type	ExpressCard/34 slot (x2)
Supplied Accessories	
Supplied Accessories	Lens hood (x1), Lens cap (x1), Infrared Remote Commander (x1), USB cable (x1), AV connecting cable (x1), BP-U30 battery pack (x1), BC-U1 battery charger (x1), Shoulder strap (x1), Lithium battery (CR2032 for backup) (x1), Lithium battery (CR2025 for the IR Remote Commander) (x1), CD-ROM: Utility software (x1) and Operating instructions in PDF (x1), Operating instructions (x1)

Distributed by

MK10902V1DNP12MAR

©2012 Sony Corporation. All rights reserved.  
Reproduction in whole or in part without written permission is prohibited.  
Features and specifications are subject to change without notice.  
Sony, CineAlta, DVCAM, Exmor, i.LINK, Memory Stick, SteadyShot, SxS,  
SxS PRO, Vegas and XDCAM are trademarks of Sony Corporation.  
All other trademarks are the property of their respective owners.

The PMW-100 is produced at Sony EMCS  
Corporation's Tokai Technology Center, which  
has received ISO14001, the Environmental  
Management System certification.

