

# SONY



## PVM-X300

4K Professional Video Monitor

TRIMASTER **4K**

XAVC

SXS

# 4K Cinema Production



# 4K Live Production

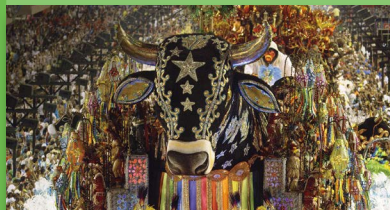

# 4K Business and Industry Production

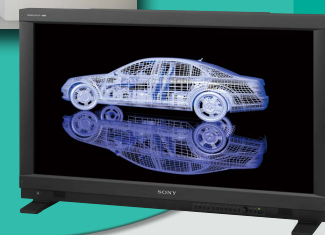

TRIMASTER  
4K



It's Time for 4K  
Don't Miss the Wave;  
Catch the PVM-X300 4K Monitor

Full-HD production has widely impacted the broadcast and video production industry, yet now another wave is forming – the 4K content creation wave. Its rise is rapid, and it looks set to dramatically change the content creation industry, especially digital cinema.

Seeing this wave develop, you may be looking around for a versatile, dependable 4K video monitor. You can catch one right now – a right-size, easy-to-use monitor for every element of the production workflow including 4K cinema production (onset monitoring, dailies, and editing), 4K live production (camera control and program preview) and real-time 4K presentation.

Sony is proud to introduce the PVM-X300, 30-inch\* true 4K (4096 x 2160 pixels) resolution LCD video monitor, ideal for 4K previewing in onset and editing applications.

The PVM-X300 monitor realizes true 4K resolution in a portable 30-inch size. It's packed with features such as a wide-viewing-angle IPS LCD panel, and versatile input interfaces including 3G/HD-SDI x 4 and HDMI x 4 inputs. In addition, it delivers a user-friendly monitor control system, and supports an optional 4K SxS™ player, BKM-XP1.

Want to review immediately the 4K images from your camera without an external box, and would you like to free yourself from complicated wired connections? It's easy with an optional 4K SxS player. Combine the PVM-X300 4K video monitor with this player to achieve an integrated total workflow with Sony's PMW-F55 4K cameras.

Catch every advantage of the 4K wave not just in film and TV production, but also in a wide range of other applications. The PVM-X300 is also ideal in industrial design and visualization systems, computer graphics systems, and in museum and laboratory environments. Catch it now!

\* 767.5 mm viewing area, measured diagonally.

## // True 4K (4096 x 2160) Resolution Panel

The PVM-X300 incorporates a 30-inch wide-viewing-angle IPS LCD panel delivering true 4K (4096 x 2160) resolution. This new professional video monitor also incorporates a RGB 10-bit panel with uniformity control, and can accurately display the industry-standard ITU-R BT.709 color space.

With its convenient size, you can easily carry the PVM-X300 to an onset site to monitor 4K resolution motion pictures. You can also achieve 4K monitoring in postproduction by putting the PVM-X300 monitor on a desk in the edit suite. From acquisition to editing, you'll have a true 4K workflow all the way. Soon you'll be wondering how you ever managed without the PVM-X300 in your production and postproduction environments!

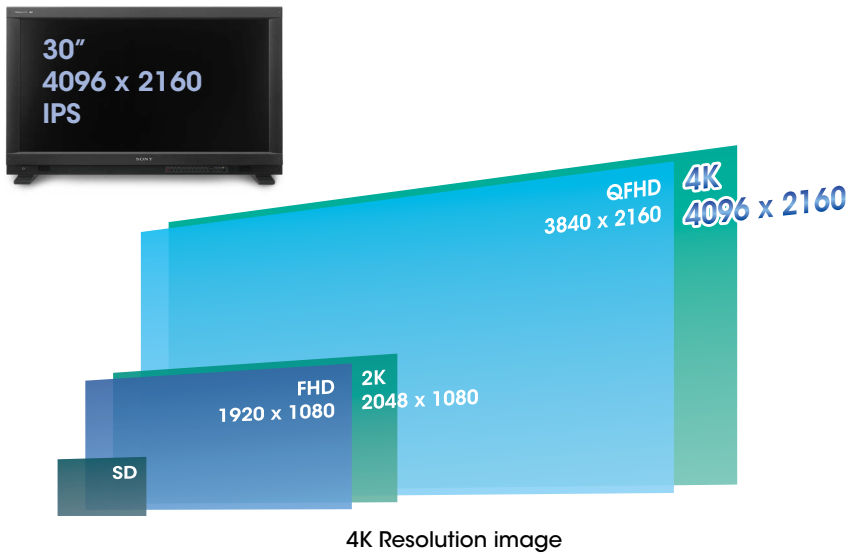

### Application images



## // Versatile Input Interfaces

The PVM-X300 4K monitor is equipped with variable interfaces including 3G/HD-SDI x 4 and HDMI x 4, allowing a direct connection with any type of 4K cinema camera and live product.

### ■ 3G/HD-SDI x 4 inputs

This monitor supports 3G-SDI receiving a wide range of 3G-SDI signals up to 4096 x 2160, 50p/60p, 10-bit Y/Cb/Cr 4:2:2.

### ■ HDMI x 4 inputs

This monitor supports 4096 x 2160/24p and 3840 x 2160/24p, 25p, 30p with one single HDMI cable. The PVM-X300 is also equipped with a unique capability – it can display 4096 x 2160/60p video signals with one single HDMI cable when connected to Sony's new PMW-F55 4K camera system.

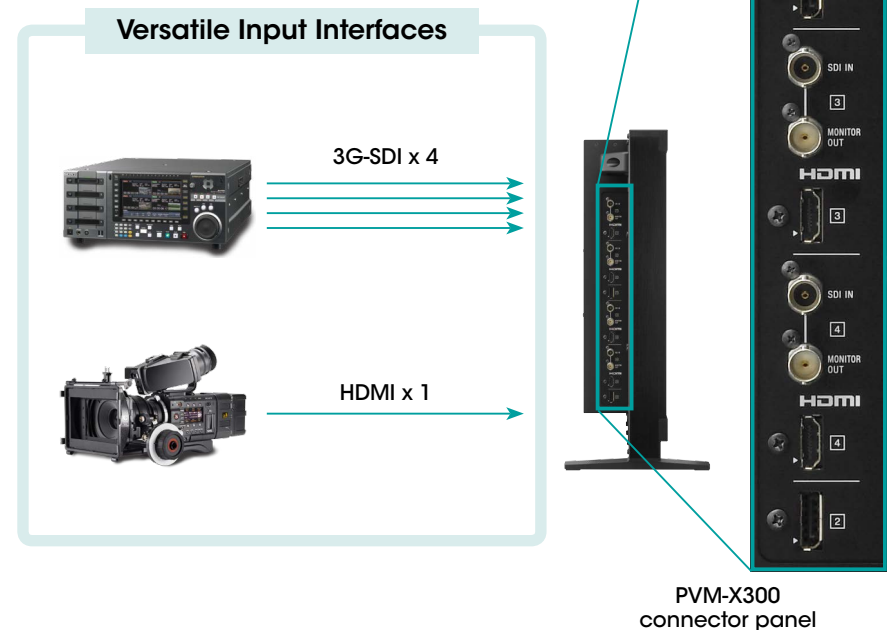

## // 4K SxS Player (BKM-XP1) (option)



You can combine the PVM-X300 with an optional 4K SxS player for easy playback of 4K content. Simply insert the newly developed SxS PRO+ high-speed memory media, which supports XAVC™ 4K and XAVC HD high-frame-rate recording, into the player to achieve immediate viewing of 4K camera images and 4K programs from a nonlinear editing system. This frees you from using an expensive, fragile HDD external player and complicated wired connections.

Thumbnails of each clip recorded on SxS PRO+ media are displayed on the monitor and can be controlled by the monitor's control panel.



\*\* Nonlinear editing alliance partners support the XAVC format.



### SxS PRO+ Media

This is a memory card for XAVC recording. XAVC is a scalable video format that supports HD, 2K, QFHD, and up to true 4K resolution. The XAVC 4K format provides exquisite 4K image quality in storage-efficient file sizes. XAVC is an open format, and is supported by industry-leading manufacturers.

## // User-friendly Control Panel Design

With its user-friendly control panel design, the PVM-X300 allows seven functions to be allocated to assignable buttons. Button lights are dimmable and indicator lights are on/off switchable - this means you can operate the monitor easily in a dark environment.

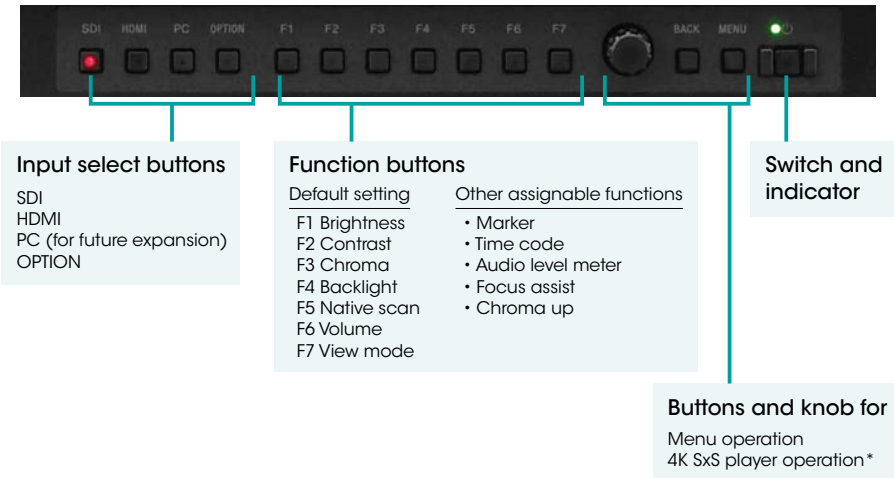

\* When the optional BKM-XP1 4K SxS player is installed, it can be operated with the monitor's control panel. In addition, the 4K SxS player can also be operated with an optional USB mouse. Operations include Clip Selection, PLAY/PAUSE, REV/FWD, and PREV/NEXT.



Thumbnail display and mouse operation

## // Display Mode

The PVM-X300 provides two basic display modes:

4K/QFHD and 2K/HD mode.

4K/QFHD mode is used for displaying 4096 x 2160 or 3840 x 2160 signal inputs.

2K/HD mode is for displaying 2048 x 1080 or 1920 x 1080 signal inputs scaled to the 4K screen.



4K/QFHD Mode

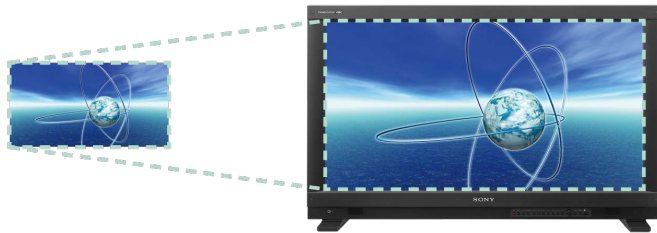

2K/HD Mode

## // Camera Focus Function

The PVM-X300 can control the aperture level of a video signal, and display images on screen with sharpened edges to help camera focus operation. Further to this, the sharpened edges can be displayed in user-selectable colors (white, red, green, blue, and yellow) for more precise focusing.

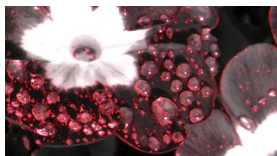

Focus in red

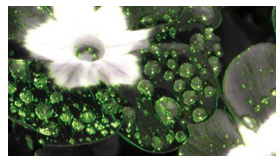

Focus in green

## // Marker Settings

This useful feature enables the PVM-X300 to display various markers including an aspect marker, safe area marker, and center marker.



images are simulated

## // Gamma Selection

The PVM-X300 supports Gamma 2.4 as specified by the ITU-R BT.1886. In addition, Gamma 2.2, 2.6, and S-Log2 can be selected.

## // Robust and Lightweight Aluminum Body

A solid aluminum housing ensures durability, especially for outdoor usage.

## // Other Convenient Features

- Audio: Stereo speakers, line out, and stereo headphone jack
- VESA™ mounting (200 x 100 mm pitch)
- Timecode display
- SDI-embedded 8-ch audio level meter display (1 to 8 ch or 9 to 16 ch)
- Chroma Up

## // Signal Format

### HD-SDI / 3G-SDI

Signal System	Signal Format	
<b>HD-SDI Single-link</b>		
1920 x 1080/60i*1, 50i, 30p*1, 30PsF*1, 25p, 25PsF, 24p*1, 24PsF*1	4:2:2 YCbCr 10 bit	
1280 x 720/60p*1, 50p, 30p*1, 25p, 24p*1		
2048 x 1080/30p*1, 30PsF*1, 25p, 25PsF, 24p*1, 24PsF*1		
<b>Quad-Link HD-SDI*2</b>		
3840 x 2160/30p*1, 30PsF*1, 25p, 25PsF, 24p*1, 24PsF*1	4:2:2 YCbCr 10 bit	Square division
4096 x 2160/30p*1, 30PsF*1, 25p, 25PsF, 24p*1, 24PsF*1		
<b>3G-SDI</b>		
1920 x 1080/60p*1, 50p	4:2:2 YCbCr 10 bit	Level A / Level B-DL
1920 x 1080/60i*1, 50i, 30PsF*1, 25PsF, 24p*1	4:4:4 RGB 10 / 12 bit	Level A / Level B-DL
1920 x 1080/30p*1, 25p, 24PsF*1	4:4:4 YCbCr 10 / 12 bit	Level A** / Level B-DL
1280 x 720/60p*1, 50p, 25p, 24p*1	4:4:4 RGB 10 bit	Level A
1280 x 720/30p*1	4:4:4 YCbCr 10 bit	Level A**
2048 x 1080/60p*1, 50p, 48p*1	4:2:2 YCbCr 10 bit	Level A** / Level B-DL
2048 x 1080/30p*1, 30PsF*1, 25p, 25PsF, 24p*1, 24PsF*1	4:4:4 RGB 10 / 12 bit	Level A** / Level B-DL
	4:4:4 YCbCr 10 / 12 bit	
<b>Dual Link 3G-SDI*2</b>		
1920 x 1080*3/60p*1, 50p	4:4:4 RGB 10 / 12 bit	Level A / Level B-DL
2048 x 1080*3/60p*1, 50p, 48p*1	4:4:4 YCbCr 10 / 12 bit	Level A** / Level B-DL
3840 x 2160/30p*1, 25p, 24p*1	4:2:2 YCbCr 10 bit	2-sample interleave division*3
3840 x 2160/30PsF*1, 25PsF, 24PsF*1		Level B-DS Square division
4096 x 2160*3/30p*1, 25p, 24p*1		Level B-DS Square division
4096 x 2160*3/30PsF*1, 25PsF, 24PsF*1	4:2:2 YCbCr 10 bit	2-sample interleave division*3
		Level B-DS Square division
<b>Quad Link 3G-SDI*2</b>		
3840 x 2160/60p*1, 50p	4:2:2 YCbCr 10 bit	Level A / Level B-DL
3840 x 2160/30p*1, 25p		2-sample interleave division*3 / Square division
3840 x 2160/30PsF*1, 25PsF	4:4:4 RGB 10 / 12 bit	Level A** / Level B-DL
		2-sample interleave division*3 / Square division
3840 x 2160/24p*1	4:4:4 YCbCr 10 / 12 bit	Level A / Level B-DL
3840 x 2160/24PsF*1		2-sample interleave division*3 / Square division
4096 x 2160/60p*1, 50p, 48p*1	4:2:2 YCbCr 10 bit	Level A** / Level B-DL
4096 x 2160/30p*1, 25p, 24p*1		2-sample interleave division*3 / Square division
4096 x 2160/30PsF*1, 25PsF, 24PsF*1	4:4:4 RGB 10 / 12 bit	Level A** / Level B-DL
		2-sample interleave division*3 / Square division
4096 x 2160/30PsF*1, 25PsF, 24PsF*1	4:4:4 YCbCr 10 / 12 bit	Level A** / Level B-DL
		Square division

### HDMI

Signal System	Signal Format	
640 x 480p@60*1	4:4:4 RGB 12 / 10 / 8 bit	
720 x 480p@60*1		
800 x 600p@60		
1024 x 768p@60		
1280 x 720p@60*1		
1280 x 720p@60*1		
720 x 576p@50		
1280 x 720p@50		
1920 x 1080i@60*1		
1920 x 1080i@50		
1920 x 1080p@60*1	4:4:4 RGB 12 / 10 / 8 bit	
1920 x 1080p@50		
1920 x 1080p@30*1		
1920 x 1080p@25		
1920 x 1080p@24*1		
2048 x 1080p@60*1		
2048 x 1080p@50		
2048 x 1080p@48*1		
2048 x 1080p@30*1		
2048 x 1080p@25		
2048 x 1080p@24*1	4:4:4 YCbCr 12 / 10 / 8 bit	
3840 x 2160p@30*1		
3840 x 2160p@25		
3840 x 2160p@24*1		
4096 x 2160p@30*1		
4096 x 2160p@25		
4096 x 2160p@25		
4096 x 2160p@24*1		
4096 x 2160p@30*1		
4096 x 2160p@25		

\*1 Also compatible with 1/1,001.

\*2 The Square division signal is also supported for Quad Link 3G-SDI, Quad Link HD-SDI, or Dual Link 3G-SDI signal systems.

\*3 Signal connectivity is currently being tested.

\*4 Audio signal is not supported.

## // Specifications

Picture Performance	
Panel	a-Si TFT Active Matrix LCD
Picture size (diagonal)	767.5 mm 30.2 inches
Effective picture size (H x V)	678.9 x 358.0 mm 26 3/4 x 14 1/8 inches
Resolution (H x V)	4096 x 2160 pixels
Aspect	17:9
Panel drive	RGB 10-bit
Viewing angle (panel specification)	89°/89°/89°/89° (typical) (up/down/left/right contrast > 10:1)
Input	
SDI	BNC (x4)
HDMI	HDMI (x4) (HDCP correspondence)
Output	
SDI	BNC (x4) Output signal amplitude: 800 mVp-p ±10% Output impedance: 75 Ω unbalanced
Audio monitor	Stereo mini jack (x1)
Speaker (built-in)	1.0 W (stereo)
Headphone	Stereo mini jack (x1)
General	
Power requirements	AC 100 V to 240 V, 2.4 A to 1.2 A, 50/60 Hz
Power consumption	Approx. 200 W (max., without mounting the option) Approx. 230 W (max., with the option mounted)
Operating temperature	0°C to 35°C (32°F to 95°F) Recommended: 20°C to 30°C (68°F to 86°F)
Operating humidity	30% to 85% (no condensation)
Storage and transport temperature	-20°C to +60°C -4°F to +140°F
Storage and transport humidity	0% to 90%
Operating, storage, and transport pressure	700 hPa to 1060 hPa
Dimensions (W x H x D)*	754 x 457 x 120 mm 29 3/4 x 18 x 4 3/4 inches 754 x 475 x 205 mm (with monitor feet) 29 3/4 x 18 3/4 x 8 1/8 inches (with monitor feet)
Mass	17 kg 37 lb 8 oz
Supplied accessories	AC power cord (1), AC plug holder (1), Operating instructions (1), CD-ROM (1)

\* The values for dimensions are approximate.

## // Dimensions

Front

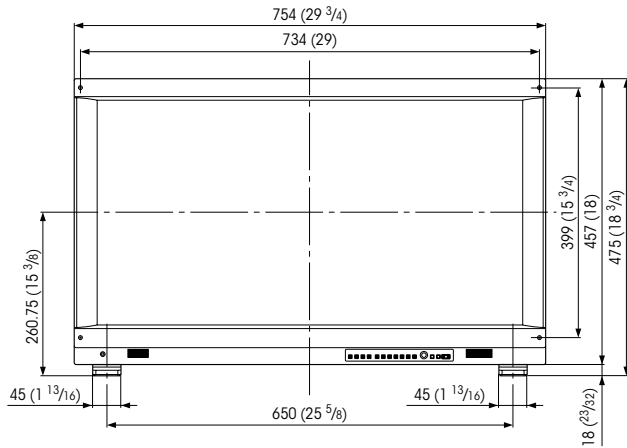

Side

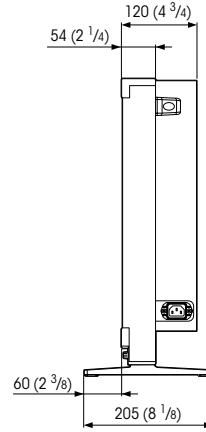

Rear

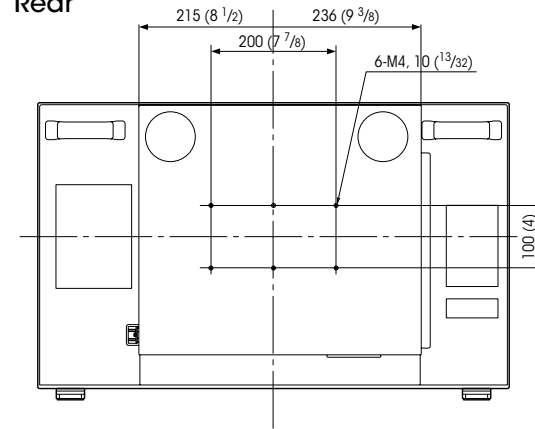

Bottom

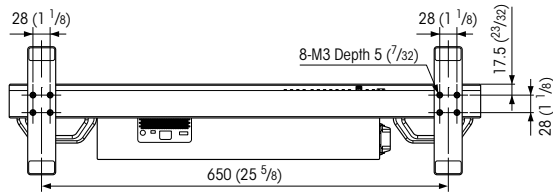

## // Optional Accessory



**BKM-XP1**  
4K SxS Player

Distributed by

MK10996V4YIT15MAR

©2015 Sony Corporation. All rights reserved.  
Reproduction in whole or in part without written permission is prohibited.  
Features and specifications are subject to change without notice.

Screen images are simulated.  
The values for mass and dimension are approximate.  
"SONY", "TRIMASTER", "SxS", and "XAVC" are trademarks of Sony Corporation.  
HDMI is a trademark of HDMI Licensing, LLC.  
All other trademarks are property of their respective owners.

The PVM-X300 is produced at Sony EMCS Corporation Kosai Site, which has received ISO 14001 Environmental Management System certification.

