

## DATASHEET

MODEL: **RADIATE D500**

### 500W DAYLIGHT 5600K HIGH INTENSITY – HMI REPLACEMENT

*Built-in power supply: direct AC or battery*

*Motorized beam control 15° to 55°*

*Compact size: L.41 cm Ø 21 cm / L.16" Ø 8.5"*

*Lightweight: 17 lbs / 8 kg*

*Touchscreen user interface + rotary encoders and CPU*

### MAIN FEATURES

500W Phosphor-Coated COB LED

DMX 512 control, RDM Ready

CRI: 90+

LED lifespan > 30,000 hours

USB input for firmware upgrades

AC-DC "hot swap" capability

Silent operation

4 selectable dimming curves, from linear to logarithmic

### FULL SPECIFICATIONS

Lens type Glass Fresnel 175mm

Weight 8 kg (17 lbs)

Beam adj. system Stepper motor

Stand Mount 16mm + 28mm (universal)

Beam Angle 15° to 55° (half peak)

AC Connection PowerCon

Power supply Built-in, universal

DC Power Supply 26 to 48V, 15A max

AC Power supply 100-240V

DMX Connection 5-pin IN + OUT

Power consumption 500W

Dimming 0,1% - 100% continuous

LED Efficiency >130 lumens/watt

Ambient temp. up to 35°C (95°F)

Cooling Active, Silent Fan

Case Color Silver or Black

CCT 5600K

Special features Touchscreen UI

Color accuracy High (3-step)

Flicker-free High FPS

Note: specifications are subject to change without prior notice



MADE IN ITALY

LED LIGHT DIMENSIONS

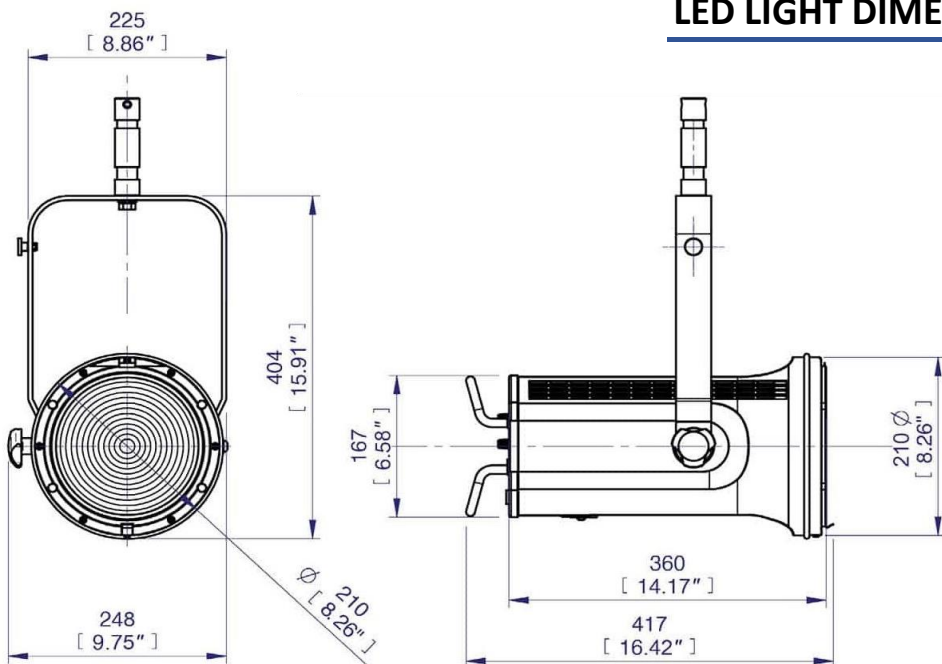

PHOTOMETRIC DATA

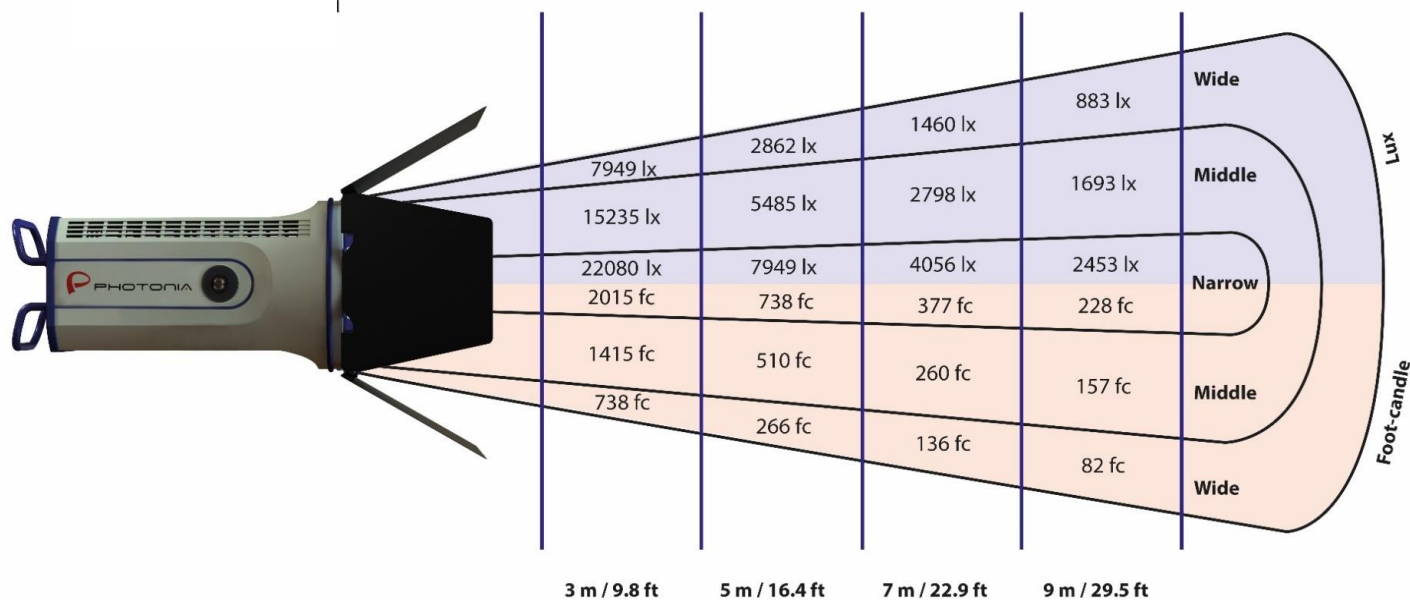

MADE IN ITALY

