

EDIROL
by Roland



R-4
Pro

**4 CHANNEL PORTABLE RECORDER
and WAVE EDITOR**

Edirol R-4 Pro - The Professional Four-Channel Portable Field Recorder

- SMPTE Time Code In/Out for Video Sync
- 4 Channel Recording
- 24 bit / 192 kHz Resolution
- 80GB Hard Disk Drive
- Instant backup via USB2.0
- Direct Connection with Computer
- Wave Editing Function

Portable 4 Channel Recorder with Superior Sound Quality and SMPTE Time Code sync function

Advantages of 4 channels recording.

- Capture more ambient sound at any shoot for an overall more convincing soundscape.
- Place mics on each participant in conferences, panels, reporters, etc.
- Redundancy or backup in case of camera mic noise or drop out.
- Simplify wedding shoots with a mic on the bride, groom, officiator and a mic for ambient sound.
- Video editing environments now support multi-channel audio as standard.

**R-4
Pro**



Top Panel

Built-In Mics

Select between input channels 1/2 and the built-in mics.

Hold Switch

Locks all control switches, including power switch.

Effects Button

Press to enter effect mode.

Wave Edit Button

Press to enter wave edit mode.

Marker Set/ Operate Buttons

Use to set markers or to index previously set markers.

A-B Repeat Button

Press once to set point A, again to set point B, and again to cancel the set points.

Display Selector

Use to select current playback time, remaining time, or current playback position bar.



Built-In Speakers

The speakers play the same sound as the headphones.

Limiter Switch

Turns the limiter of all channels ON or OFF.

Phantom Power Switch

Turns the phantom power ON or OFF for channels 1/2 and 3/4 during mic input.

Shuttle Dial

Use to vary forward or reverse speed in playback or in waveform editing.

Jog Dial

Use to select files and set parameters.

Cursor/Monitor Select Buttons

Use to select files and menu items and to set parameters.

Front Panel

LCD

Large 128x x 64 dot display

Input Sens & Gain dials

Dual type dials to set input sens and gain. Each channel can be set independently at the analog stage



Prev Button

Press to select previous file. Hold it down to rewind.

Next Button

Press to select the next file. Hold it down to fast-forward.

REC Button

Press to start recording. Press while holding down the PAUSE button to enter standby recording.

Monitor Level Dial

Volume control for built-in speakers and headphone.

Right Panel



Input Terminals (Ch 1 to 4)

XLN type jacks with switchable phantom power

Line Out Terminals

RCA jacks x 4 for Independent monitoring of all channels.

Left Panel



USB Terminals

For external storage and computer connection

DC Input

Use to supply DC power from external battery or AC adaptor

AES/EBU Input/Output

Digital Audio input and output

Time Code Input/Output

Use to sync with external video devices as master or slave.

Headphone Jack

Standard headphone jack.

The R-4 Pro shares the R-4's rugged construction, robust feature set and great sound quality, but the R-4 Pro also includes AES/EBU support, SMPTE time code and superb electronics. Record up to four channels at 24-bit 96KHz and monitor each channel discretely. The durable DC input jack allows for industry-standard battery packs to extend your record time. Its 80GB hard drive will store up to 116 hours of high quality audio. You can plug in any standard USB drive and enjoy fast back-ups of your projects. Like the R-4, the R-4 Pro has on-board effects and WAV editing features. Geared for pro videographers and recordists, the R-4 Pro delivers professional sound and features in a package that everyone can afford.

AES/EBU Input/Output

The R-4 Pro is equipped with XLR style AES/EBU digital input and output for connection with pro Audio and Video recorders or sources.

Individual Monitoring of 4 channels

Individual monitoring of all channels is enabled via the four analog outputs. This allows precise monitoring of all recorded audio.

Superior 24-bit/192-kHz Linear Recording

Totally uncompressed recording assures outstanding sound quality. Choose 16-bit or 24-bit quantization and a sampling rate of 44.1 kHz to 192 kHz. Save data as BWF or WAV files.

Extended Recording with 80GB Hard Disk Drive

Equipped with a 80GB hard disk drive, the R-4 Pro can record a stereo audio file for following hours.

Recording Time (Stereo)

	16bit	24bit
44.1kHz	116hours	77hours
48kHz	106hours	70hours
88.2kHz	58hours	38hours
96kHz	53hours	35hours
192kHz	26hours	17hours

* These recording times are approximate. Your actual results may vary somewhat.

* If more than one recorded file exists, the total recordable time will be less than these.

Simultaneous 4-Channel Recording

The 4 XLR jacks come with switchable phantom power and give you a choice of MONO, STEREO, STEREO X2, or 4CH recording. Digital input/output is also provided. Four-channel recording gives you exceptional flexibility.

On-Board Limiter (selectable)

Built into the analog stage, the Limiter helps deliver a stable and reliable recording free of clipped noise from sudden input surges.

■ Limiter Operation

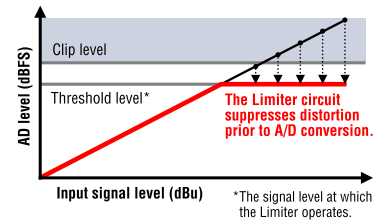

Built-In Nondirectional Stereo Microphones

The R-4 Pro's omnidirectional, back electret condenser microphones offer superb transient characteristics and vibration resistance.

Pre-Recording Function

When the REC button is pressed, the current material is appended to a buffer that contains recorded material from a few seconds earlier. This helps prevent missed recording opportunities or sound bites at the beginning of a recording.

Computer Linking

USB 2.0 provides a High Speed Computer Data Link. You can transfer the data about 20 times faster than DAT. You can also use R-4 Pro as a 80GB storage device. Edit R-4 Pro files directly from DAWs and other applications.



Master or Slave Sync with SMPTE Time Code

The R-4 Pro accepts SMPTE time code which enables it to slave to video cameras or VCRs. Four channels of high quality audio can be fully synchronized with video. In addition, the R-4 Pro can also act as the master, sending out time code to slave devices.



Instant Backup via USB 2.0

The USB host terminal of R-4 Pro enables high speed and instant backup of recorded data to affordable and easy obtainable media like Flash Memory, Memory Cards via card reader or HDD storage. Easy and high speed duplication of recorded data improves production workflow across multiple locations.



DC Input for External Battery Power Supply

The R-4 Pro is equipped with a 4-pin XLR type battery power input. This enables power supplies from industry standard battery manufacturers for video cameras such as Anton-Bauer, etc. Additional flexibility in power options include AA type battery power or AC power (via adapter).

Wave Editing

Just watch the waveform on the LCD.

Scrubbing playback with the shuttle dial let you set the edit points precisely by sound.

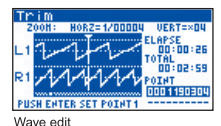

Operation Screens

The large 128x68 LCD display enables easy/intuitive operations

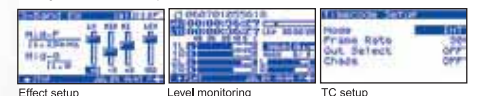

Newly designed High Quality Pre-amps

The high quality R-4 Pro pre-amps specially designed for field recording ensures superior sound quality.



Six High-Quality Effects

The R-4 Pro lets you tailor the sound during both recording and playback.

Built-In Effects

3-Band EQ	3-band parametric EQ; allows precise equalization with high/low shelving and mid peaking
Graphic EQ	6-point frequency band equalizing-ideal for recording
Noise Gate	Minimizes noise during silences, cuts low-frequency noise
Enhancer	Clearly defines and enhances sounds-good for dialogue
Comp & DeEsser	Cuts hissing, smoothens the sound, makes the sound level uniform
MS Mic Mixing	Generate stereo mix with specified spread from inputs of Mid-Side Microphones

*Only one effect can be used at a time. Effect ON/OFF and parameters can be set for each track.
*Effects are not available in 96-kHz or higher sampling rate operation.

Dimension Chart (mm)

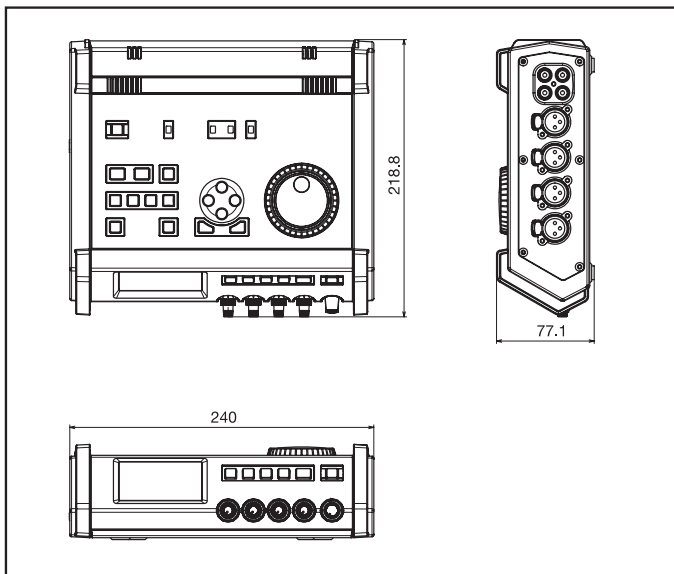

Specifications

Recorder Part	
Channels	4
Signal Processing	
AD/DA Conversion	24bits
Sampling Frequency	44.1/48/88.2/96/192 kHz(*1)
Data Type	
Format	BWF, WAV
Bit Depth	16/24bits
Recording Media	
Type	Internal Hard Disk Drive
Capacity of HDD	80GB
Effect Unit	
Tone Control	3Band Shelving EQ, 6band Graphic EQ, Noise Gate, Enhancer, Compressor and De-esser, MS Mic Mixing (*2)
Time Code	
Frame Rate	24, 25, 29.97D, 29.97ND, 30D, 30ND fps
Running Mode	Internal (free run), External, REC Run, RTC
Jamming Mode	Manual, External
Clock Accuracy	Max Error Rate : 80ppm
Input and Output	
Input	
Connectors	Analog Audio : XLR type x 4 (phantom powered) Digital Audio : AES/EBU (XLR 3 pin type) x 1 SMPTE Time Code : BNC type x 1 DC Power : XLR 4 pin type x 1 (for external battery)
Built in Microphones	Omnidirectional, back electret condenser type x 2
Impedance	Analog Input : 4 k Ohms
Frequency Response	44.1kHz : 20Hz to 20kHz (0dB/-2dB) 48kHz : 20Hz to 22kHz (0dB/-2dB) 88.2/96/192kHz : 20Hz to 40kHz (0dB/-3dB)
Nominal Input Level (Sens Level)	-56, -50, -44, -38, -32, -26, -20, -14, -8, -2, +4 dBu (Input Level Knob : Center)
S/N Ratio	100dB
Output	
Connectors	Analog Audio : RCA pin type x 4 Digital Audio : AES/EBU (XLR 3 pin type) x 1 SMPTE Time Code : BNC type x 1 Headphone : Stereo Phone type (1/4 inch) x 1
Impedance	Analog Audio : 950 Ohms, Headphone : 10 Ohms
Output Level	Line Output : -10dBu Headphone : 40mW + 40mW
Built in speakers	3.5cm x 2cm Oval type x2
Other Connectors	
USB 2.0 connectors	A type x1, B type x 1 (*3)
Others	
Power Supply	DC9V(AC Adaptor), AA Battery x 8 or External Battery (9-16V)
Dimension and Weight	254(W) x 221.8(D) x 72.2(D) mm, 1.7kg or 9-1/2(W) x 8-9/16(D) x 3-1/16(H) inches, 3 lbs 12oz
Accessories	USB Cable, AC Adaptor with XLR 4 pins conversion Cable, Owner's Manual, Carrying Case (soft type)

*1 : Limited to Stereo x 1 when 192kHz

*2 : Invalid when sampling rate is 88.6/96/192kHz

*3 : Mass Storage Class. System Requirements : Windows (R) XP/2000/Me, MacOS 9.2 or MacOS X, OS standard driver

Block Diagram

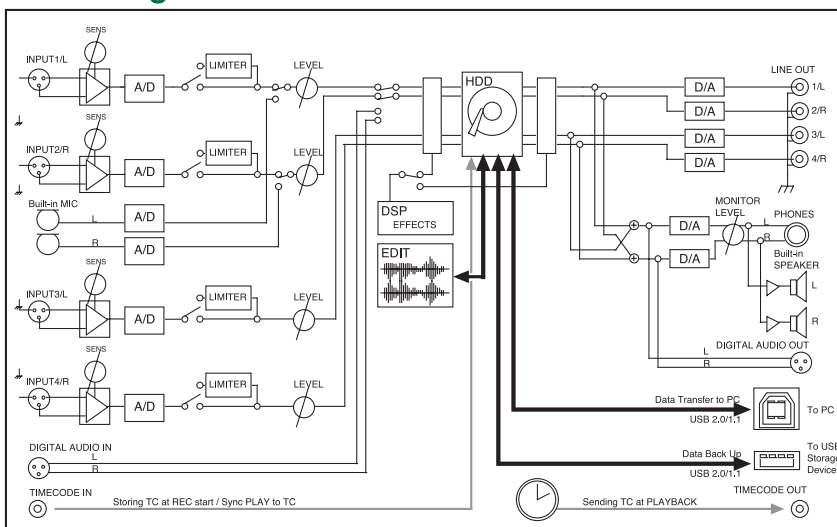

Optional and related items

For stereo recording in the field

CS-50

High quality headphones for audio monitoring

RH-200 RH-300

Dedicated hard-type carrying case

SHC-R4

R-4

The R-4 is a very cost effective solution to use with the many SD and HDV cameras not equipped with time code. Especially convenient is the L-control connector that allows the R-4 to pause, record, stop along with the camera.

EDIROL
by Roland

Roland
WE DESIGN THE FUTURE

www.rolandsystemsgroup.net