

SHARP

PN-Q601E/PN-Q701E/PN-Q801E/PN-Q901E
Professional LCD Displays

Creating a great impression is essential /**This is Why** we created the PN-Q series of affordable, large and professional displays.



YOUR ORGANISATION DESERVES TO SHOW ITSELF IN THE BEST POSSIBLE LIGHT WITH AN AFFORDABLE ANSWER TO YOUR SIGNAGE AND DISPLAYS NEEDS.

Sharp's PN-Q series of large, professional displays combine great features with an attractive design. Cost-effective, and with a three-year warranty providing professional support and service if required, they are the ideal choice for a wide variety of everyday applications where robust, reliable displays are needed to make the right impact.

You need professional level features. /This is Why the Sharp PN-Q range was designed to meet your needs every day.

Maximum impact when you really need it

Designed for continuous use during retail and business hours, and in other high demand applications, the Sharp PN-Q range of affordable, large and professional displays is designed to offer a broad appeal for a wide range of professional settings.

The exacting specifications and impressive size of these robust and long-lasting panels, will ensure your content has a high impact that gets viewers' attention even in areas with high ambient light levels.

Sharp's proprietary UV²A LCD technology, which continuously offers brilliant images over the display lifetime, creates deep, true blacks and crystal-clear whites, with an advanced pixel structure and 5000:1 contrast ratio. This is reinforced by powerful audio capabilities, thanks to 10W + 10W speakers, to complement your video content even in those areas where background noise might otherwise detract.

And because we know you don't just need superb image quality but you need to know it will always be displayed at its very best, the PN-Q series gives you 1920 x 1080 display resolution and a 178-degree viewing angle, which ensures on-screen content is visible from the maximum range of positions around the display.

Connectivity, commands, and control

The PN-Q series' full-HD video and audio is delivered via one of three HDMI ports, a single common standard cable for ease-of-use, and hassle-free connection to digital signage sources. The range also offers direct playback of photos, videos, and audio directly from the USB port, eliminating the need for additional playback devices.

RS-232C command set, and Ethernet connectivity, provide flexible remote control capabilities from connected devices that will enable businesses to keep track of displays remotely, performing cost-saving commands, such as turning off all displays outside of business hours and wake-on-LAN, where required.

Once your content is being displayed in its best light, you need to know it will stay that way, which is why the PN-Q range is fitted with a series of lockdown options. This important feature will allow users to disable access to LED backlight setting, infrared remote control sensors, power and volume control buttons, and on-screen display functions to prevent tampering when the display is installed in a public space.



Your displays should be professional and presentable. /This is Why the PN-Q series has been beautifully designed for a range of applications.

An affordable, professional display unit with high quality appeal

Sharp designed the PN-Q series of large, professional displays as a practical, robust choice for a wide range of applications, from retail spaces and shops, to hotels, corporate office meeting rooms, and public spaces.

In addition to the superb quality and manageability customers have come to expect from Sharp, that means ensuring the display units themselves will be compatible with many different uses and in many different potential locations, and always create the right impression.

One way we have ensured this is through the PN-Q series' thin profile, which measures 11.15mm (right/left), 10.85mm (top), and 15.65mm (bottom) on the PN-Q701E enabling easy and great looking installation.

This is further enhanced by the stylish design of the PN-Q series' thin (8.8mm on the PN-Q701E) bezel, adding an overall effect that helps to improve the impact of displayed content, by contributing to the complete visual impact.

The high quality design, look, and feel of the PN-Q series results from Sharp's pedigree and experience in display design. The PN-Q series offers slightly varying cabinet styles in the four different sizes, which are all stylish, sleek and have good looking appeal for use in public spaces.



MODEL SHOWN PN-Q701E WITH STAND

Specifications

Model		PN-Q701
Installation		Landscape
LCD Panel		70" Class (69 1/2" diagonal) TFT LCD
Max. Resolution		1920 x 1080 pixels
Max. Display Colours (approx.)		1.07 billion colours
Pixel Pitch (H x V)		0.8015 x 0.8015 mm
Max. Brightness*1 (average)		350 cd/m ²
Contrast Ratio		5,000 : 1
Dynamic Contrast Ratio		4,000,000 : 1
Viewing Angle (H/V)		176°/176° (CR≥10)
Active Screen Area (W x H) (approx.)		60.6" x 34.0"
Response Time		4 ms (grey to grey, avg.)
Backlight		LED, edge lit
Computer Input		HDMI, Analogue RGB
Synchronisation		Horizontal/vertical separation (TTL: positive/negative)
Plug & Play		VESA DDC2B
Video Color System		NTSC-M/PAL-N/PAL-M
Input Terminals*2		HDMI x 3, Mini D-sub 15-pin x 1, Component Video RCA (Y, Cb/Pb, Cr/Pr) x 1, Composite Video RCA pin x 2, RCA pin (L/R) x 2, 3.5 mm-diameter mini stereo jack x 1, RS-232C x 1, USB x 1
Output Terminals*2		Audio: RCA pin (L/R) x 1, Digital audio output (optical) x 1
Input/Output Terminals*2		Ethernet RJ-45 x 1
Speaker Output		10 W + 10 W
Power Supply		110 – 240V AC, 50/60Hz
Power Consumption		180W
Operating Temperature		0°C to 40°C
Dimensions (W x D x H) (approx.) (display only)		1,563 x 87 x 908 mm (61 35/64" x 3 7/16" x 35 3/4")
Weight (approx.)		33.5 kg

PN-Q601E/PN-Q801E/PN-Q901E will be launched at a later date

Notes

*1 Brightness will depend on input mode and other picture settings. Brightness level will decrease over time. Due to the nature of the equipment, it is not possible to precisely maintain a constant level of brightness. *2 Use a commercially available connection cable for PC and other video connections.

Design and specifications are subject to change without prior notice. All information was correct at time of print. Windows, Windows Server, and Windows Vista are registered trademarks of Microsoft Corporation in the United States and/or other countries. All other company names, product names and logotypes are trademarks or registered trademarks of their respective owners. © Sharp Corporation. February 2017. Ref PN-Q601E/PN-Q701E/PN-Q801E/PN-Q901E Brochure 4pp (17904).

Dimensions

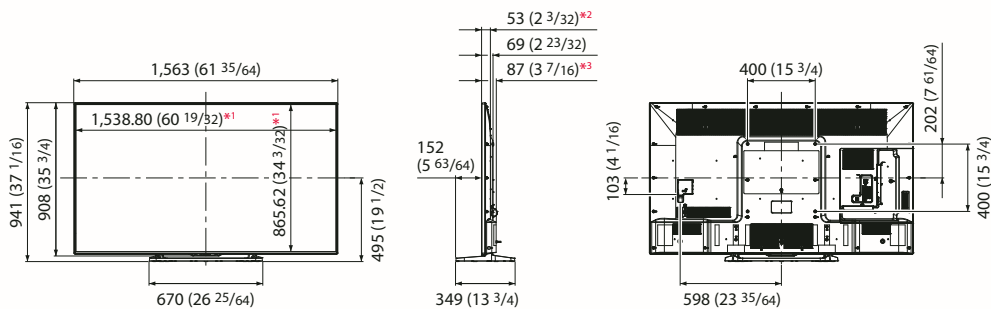

Units: mm (inch)

*1 Active area, *2 Thinnest part, *3 Including projecting parts

SHARP

Inspiring ideas from technology

www.sharp.eu

HDMI™
HIGH DEFINITION MULTIMEDIA INTERFACE