

4K UHD PTZ Video Camera

User Manual

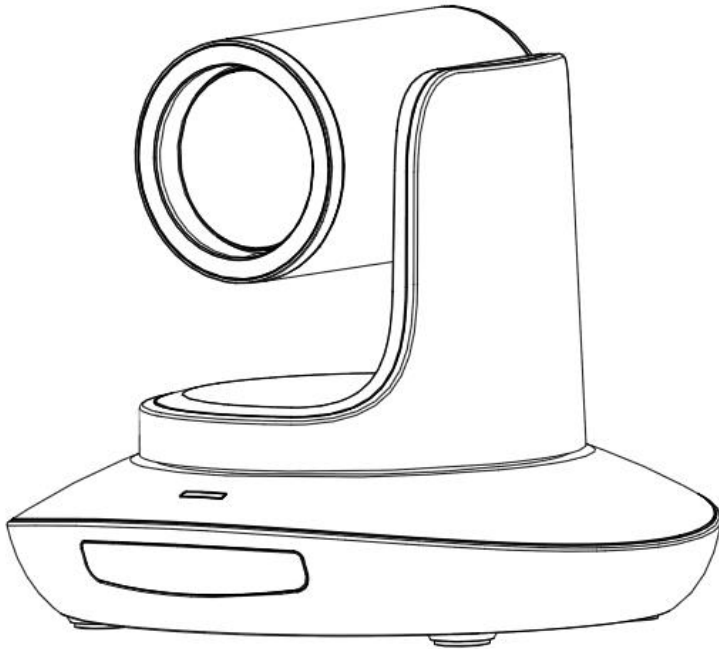

Version V1.2
(English)

CONTENT

| | |
|-------------------------------|----|
| CONTENT..... | 1 |
| SAFETY GUIDES | 2 |
| PACKING LIST..... | 3 |
| QUICK START | 3 |
| PRODUCT HIGHLIGHTS | 4 |
| CAMERA SPEC | 4 |
| CAMERA INTERFACE | 6 |
| CAMERA DIMENSION | 6 |
| IR REMOTE CONTROLLER | 7 |
| VISCA IN (RS232 PORT)..... | 9 |
| VISCA PROTOCOL | 10 |
| PELCO-D PROTOCOL | 19 |
| PELCO-P PROTOCOL | 20 |
| OSD MENU | 21 |
| UVC CONTROL | 24 |
| WEB SETTING | 25 |
| VIEW RTSP VIDEO VIA VLC | 30 |
| VISCA OVER IP | 31 |

SAFETY GUIDES

1. Before operation, please fully read and follow all instructions in the manual. For your safety, always keep this manual with the camera.
2. The camera power input range is 100-240VAC(50-60Hz), ensure the power supply input within this rate before powering on.
3. The camera power voltage is 12VDC, rated current is 2A. We suggest you use it with the original power supply adapter supplied by the factory.
4. Please keep the power cable, video cable and control cable in a safe place. Protect all cables especially the connectors.
5. Operational environment: 0°C-50°C, humidity less than 90%. To avoid any danger, do not put anything inside the camera, and keep away from the corrosive liquid.
6. Avoid stress, vibration and damp during transportation, storage and installation.
7. Do not touch the camera housing and cover. For any service, please contact authorized technicians.
8. Video cable and control cable should be individually shielded, and cannot be substituted with other cables. Do not direct the camera lens towards strong light, such as the sun or the intensive light.
9. Use a dry and soft cloth to clean the camera housing. Applied with neutral cleaning agent when there is need to clean. To avoid damage on the camera lens, never use strong or abrasive cleaning agents on the camera housing.
10. Do not move the camera by holding the camera head. To avoid mechanical trouble, do not rotate the camera head by hand.
NEVER MOVE THE CAMERA MANUALLY WHEN IT IS WORKING.
11. Put the camera on fixed and smooth desk or platform, avoid leaned installation.
12. Power Supply Polarity (Drawing)

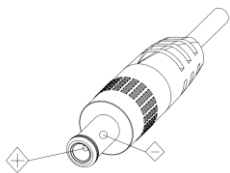

Note:

The video quality may be affected by the specific frequencies of electromagnetic field.

Never grasp the head of the camera, and never move the camera by hand when it is working, otherwise, mechanism may be destroyed.

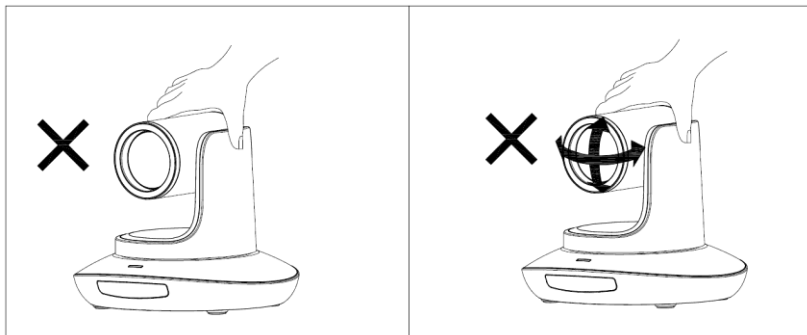

PACKING LIST

Check all below items when open the package:

| | |
|-----------------------------|---|
| Camera | 1 |
| Power Adapter | 1 |
| Power Cable | 1 |
| RS232 Control Cable | 1 |
| USB3.0 Cable | 1 |
| Remote Controller | 1 |
| User Manual | 1 |
| Double-sided Adhesive | 1 |
| QC certification | 1 |

QUICK START

1. Check all cable connections before power on.

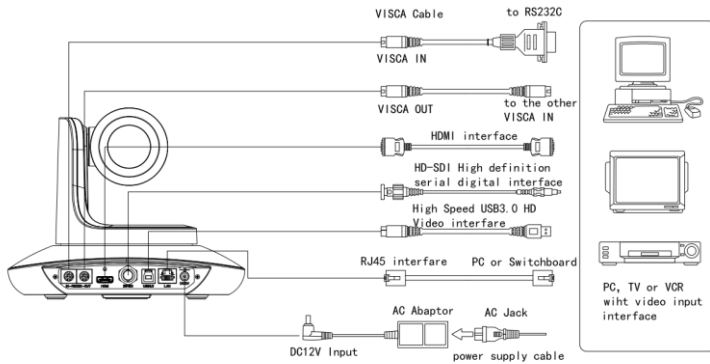

2. Dial Switch Setting (at the bottom of the camera):

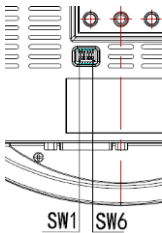

| Dial Switch (ARM) | | | |
|-------------------|------|------|----------------|
| | SW-1 | SW-2 | Instruction |
| 1 | OFF | OFF | Updating mode |
| 2 | ON | OFF | Debugging mode |
| 3 | OFF | ON | Undefined |
| 4 | ON | ON | Working mode |

| Dial Switch | | | |
|-------------|------|------|-------------|
| | SW-3 | SW-4 | Instruction |
| 1 | OFF | OFF | reserve |
| 2 | ON | OFF | reserve |
| 3 | OFF | ON | reserve |
| 4 | ON | ON | reserve |

| Dial Switch (USB) | | | |
|-------------------|------|------|---------------|
| | SW-5 | SW-6 | Instruction |
| 1 | OFF | OFF | Undefined |
| 2 | ON | OFF | Working mode |
| 3 | OFF | ON | Updating mode |
| 4 | ON | ON | Undefined |

PRODUCT HIGHLIGHTS

- Adopts most advanced ISP, 1/2.5 inch 8.5MP sensor, providing 3840x2160 p30 Ultra HD video resolution.
- 4K wide angle optical lens: 12x optical zoom and 2x digital zoom , with 72.5 degree field of view.
- 4K video over IP, H.264, H.265 encoding.
- IP, HDMI, 3G-SDI, USB outputs, fit for different application, 4K video streaming over IP and HDMI optional.
- White Balance, Exposure, Focus, Iris can be adjusted automatically or manually.
- Support POE: one single CAT5/6 to get video, control and power supply.
- Special Focusing Algorithm: fast and precise focusing performance when zooming or moving.
- Smooth PTZ mechanical design, accurate pan tilt motor control.
- 128 presets supported; Exposure parameter and white balance parameter can be saved in presets (in manual mode).
- Standard Sony VISCA, IP VISCA, PELCO-P, PELCO-D control protocol; IP VISCA over both TCP and UDP.
- Daisy chain supported, max 7 cameras connected in VISCA protocol.
- Image flip function, support upside-down installation.
- Supplied with functional IR remote controller, can set IP address via OSD menu.
- Fast video format switch: less than 3 seconds.
- Supported field upgrade for ISP, ARM, FPGA and USB.
- USB3.0 port compatible with USB2.0 output.
- Support RS232/RS485/UVC control.
- Standard UVC1.5 protocol, seamlessly compatible with major video conferencing software and platform.
- Support IR transfer function, code of the third party remote controller can be transferred to the host via VISCA IN port, in case client's development.
- OSD menu in English and Chinese supported. IP address, streaming resolution and size can be set in OSD menu.

CAMERA SPEC

| | | |
|-----------------|--|--|
| Video Format | HDMI | 3840*2160P30/25 1920*1080P60/50/30/25/59.94/29.97/24 1920*1080I60/50/59.94 1280*720P60/50/30/25/59.94/29.97 |
| | SDI | 1920*1080P60/50/30/25/59.94/29.97/24 1920*1080I60/50/59.94 1280*720P60/50/30/25/59.94/29.97 |
| | USB | 1920*1080P60/50/30/25(USB3.0) 1280*720P60/50/30(USB3.0) 1280*720P25(USB3.0&USB2.0) 1024*576P30(USB3.0&USB2.0) 960*540P30(USB2.0) 640*360P30(USB2.0) 512*288P30(USB2.0) |
| | RJ45 | Main Stream: 3840*2160@15~30;1920*1080@15~30; 1280*720@15~30; 1024*576@15~30 Sub Stream: 1280*720@15~30;;1024*576@15~30,640*360@15~30 |
| Video Interface | HDMI, SDI, RJ45, USB3.0, USB2.0 | |
| Sensor | 1/2.5" 8.5MP CMOS sensor | |
| Zoom | f3.92 ~ 47.32mm(12X), F1.8 – 2.8, View Angle:72.5°(Far)-6.3°(Near) | |
| Rotation Angle | Pan: -170° ~ +170°; Tilt: -30° ~ +90° | |
| Rotation Speed | Pan: 0°~120°/s ; Tilt: 0°~80°/s | |
| Preset: | Remote controller: 10; RS232: 128; Accuracy: 0.1° | |

| | |
|--------------------|---|
| Control Port | RS232, RS485, RJ45(VISCA over IP), USB3.0(UVC1.5), USB2.0(UVC1.1) |
| Network Speed | 1000M |
| Video encode | H.264/H.265 |
| Bit Rate Control | Variable Bit Rate, Constant Bit Rate |
| Video Bit Rate | 1024Kbps~51200Kbps |
| IP Protocol | TCP/IP, HTTP, RTSP, DHCP ,RTMP, Onvif |
| POE | Supported |
| Daisy Chain | Support RS232 serial daisy chain |
| Minimum Lux | 0.01lux |
| White Balance | ATW/Manual/Auto/Indoor/Outdoor/Push |
| Exposure | Auto/Manual/Shutter/Iris/Bright |
| Focus | Auto / Manual |
| Iris | Auto / Manual |
| Electric Shutter | Auto / Manual |
| Gamma | Supported |
| WDR | Supported |
| BLC | Supported |
| 2D Noise Reduction | Supported |
| 3D Noise Reduction | Supported |
| Anti Flicker | OFF/50Hz/60Hz |
| PanTilt Flip | Supported |
| Input Voltage | DC12V/POE+(IEEE802.3at) |
| Dimension | 220mm×190mm×173mm |
| Net Weight | 1.4KG |

Note: when HDMI port output 4K, USB and SDI port no video output.

CAMERA INTERFACE

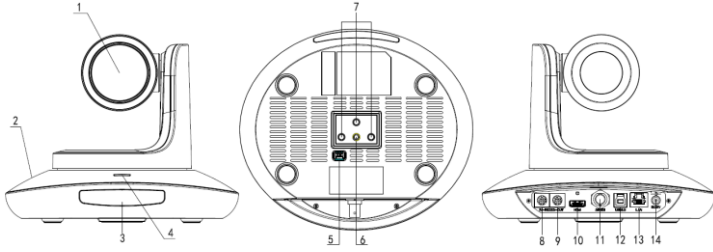

- 1. Camera Lens
- 2. Camera Base
- 3. IR Receiver Panel
- 4. Power Indicator Light
- 5. Dial Switch

- 6. Tripod Screw Hole
- 7. Installation Hole
- 8. RS232 control port (input)
- 9. RS232 control port(output)
- 10. HDMI port

- 11. 3G-SDI port
- 12. USB port
- 13. RJ45 port
- 14. DC12V plug

CAMERA DIMENSION(MM)

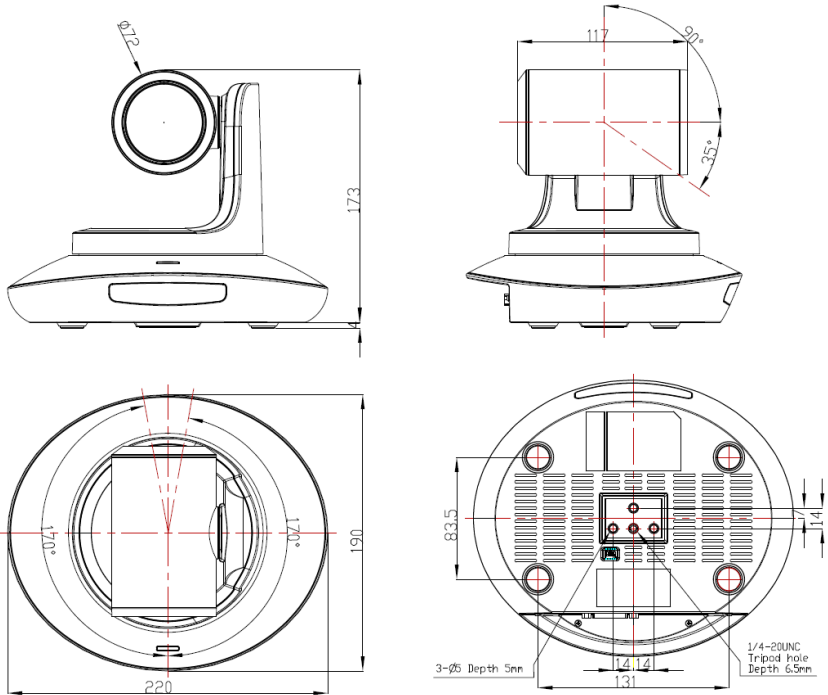

IR REMOTE CONTROLLER



POWER

Under normal working mode, short press POWER key, to enter standby mode; Press it again, the camera will do self-configuration, then go back to HOME position. It will go to preset position if power on model has been set before.

FREEZE (Not Supported in USB)

Short press FREEZE key to freeze/ unfreeze the image.

IRT (IR Transfer/IR Pass)

Open / close the IR pass function. Once press the IRT key, the camera will receive and Pass the IR remote control signal to the codec/terminal (via VISCA IN port).



SET 1~SET4 ADDRESS SETTING

Long press for 3seconds until the key light ON, to set camera address.

CAM1~CAM4 (CAMERA SELECTING)

Short press to select the relative camera.

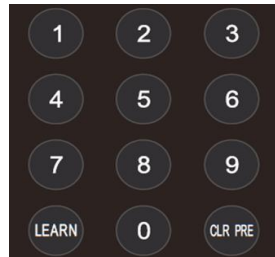

NUMBER KEY (1-9)

Set preset: long press (3 seconds) the number key to set preset.

Run preset: Short press the number key to run preset.

CLR PRE (CLEAR PRESET)

CLR PRE+ number key: to clear the relative preset.

Long press to clear all preset.



FOCUS KEY (ON THE LEFT)

Manual focus, only valid under manual focus model.

ZOOM KEY(ON THE RIGHT SIDE)

Set the zoom rate

NAVIGATE KEY: UP/DOWN/LEFT/RIGHT

Under working mode, use navigate key to set the pan tilt, and select menu when enter OSD.

OK /HOME KEY

Under working mode, short press OK to make the camera go back to HOME position; and confirm the selection when enter OSD.



AF: Auto Focus

MF: Manual Focus

RESET: Press 3 seconds to reset camera

MENU: Enter OSD menu



LEARN+LIMIT L key: Set the pan tilt left limit position.

LEARN+LIMIT R key: Set the pan tilt right limit position.

LEARN+LMT CLR key: Clear the limit position.

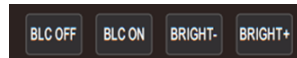

BLC OFF/ BLC ON: Not Available

BRIGHT-/BRIGHT+: Set image brightness, only valid under bright priority exposure mode.



Video Format Keys:

Long press 3 seconds to select different video format output.

Note:

Long press F3 to switch to 3840*2160P30 mode (HDMI)

Long press F4 to switch to 3840*2160P25 mode (HDMI)

VISCA IN (RS232 PORT)

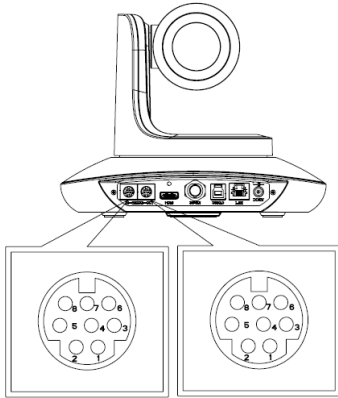

| No. | V_IN | V_OUT |
|-----|--------|-------|
| 1 | DTR | DTR |
| 2 | DSR | DSR |
| 3 | TXD | TXD |
| 4 | GND | GND |
| 5 | RXD | RXD |
| 6 | A | |
| 7 | IR OUT | |
| 8 | B | |

| VISCA IN | RS485 |
|----------|--------|
| 1 | |
| 2 | |
| 3 | |
| 4 | |
| 5 | |
| 6 | A(+) |
| 7 | IR OUT |
| 8 | B(-) |

VISCA IN & Mini DIN Connection

| Camera VISCA IN | | Mini DIN | |
|-----------------|--------|----------|-----|
| 1 | DTR | 1 | DSR |
| 2 | DSR | 2 | DTR |
| 3 | TXD | 5 | RXD |
| 4 | GND | 4 | GND |
| 5 | RXD | 3 | TXD |
| 6 | A(+) | 6 | NC |
| 7 | IR OUT | 7 | NC |
| 8 | B(-) | 8 | NC |

VISCA IN & DB9 Connection

| Camera VISCA IN | | Windows DB-9 | |
|-----------------|--------|--------------|-----|
| 1 | DTR | 6 | DSR |
| 2 | DSR | 4 | DTR |
| 3 | TXD | 2 | RXD |
| 4 | GND | 5 | GND |
| 5 | RXD | 3 | TXD |
| 6 | A(+) | | |
| 7 | IR OUT | | |
| 8 | B(-) | | |

VISCA Network Construction:

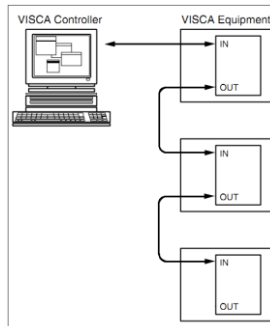

SERIAL PORT CONFIGURATION

| Parameter | Value | Parameter | Value |
|-----------|-----------------------|-----------|-------|
| Baud rate | 2400/4800/9600/115200 | Stop Bit | 1bit |
| Start Bit | 1 bit | Check Bit | None |
| Date Bit | 8 bit | | |

VISCA PROTOCOL

Part1 Camera Return Command

| Ack/Completion Message | | |
|------------------------|----------------|--|
| | Command Packet | Note |
| ACK | z0 41 FF | Returned when the command is accepted. |
| Completion | z0 51 FF | Returned when the command has been executed. |

z = camera address+8

| Error Messages | | |
|------------------------|----------------|---|
| | Command Packet | Note |
| Syntax Error | z0 60 02 FF | Returned when the command format is different or when a command with illegal command parameters is accepted |
| Command Not Executable | z0 61 41 FF | Returned when a command cannot be executed due to current conditions. For example, when commands controlling the focus manually are received during auto focus. |

Part 2 Camera Control Command

| Command type | function | command | |
|---------------|----------------------------|-------------------------------|--|
| AddressSet | Broadcast | 88 30 01 FF | Address setting |
| IF_Clear | Broadcast | 88 01 00 01 FF | I/F Clear |
| CommandCancel | | 8x 21 FF | |
| CAM_Power | On | 8x 01 04 00 02 FF | Power ON/OFF |
| | Off | 8x 01 04 00 03 FF | |
| CAM_Zoom | Stop | 8x 01 04 07 00 FF | p = 0(low)~7(high) |
| | Tele(Standard) | 8x 01 04 07 02 FF | |
| | Wide(Standard) | 8x 01 04 07 03 FF | |
| | Tele(Variable) | 8x 01 04 07 2p FF | |
| | Wide(Variable) | 8x 01 04 07 3p FF | |
| | Direct | 8x 01 04 47 0p 0q 0r 0s FF | |
| CAM_DZoom | Direct with speed | 8x 0A 04 47 0t 0p 0q 0r 0s FF | t: spd 0~7 pqrs: Zoom Position (0(wide)~0x4000(tele)) |
| | ON | 8x 01 04 06 02 FF | |
| | OFF | 8x 01 04 06 03 FF | |
| | Combine Mode | 8x 01 04 36 00 FF | Combine with optical zoom control |
| | Separate Mode | 8x 01 04 36 01 FF | Separate with optical zoom control |
| | Stop | 8x 01 04 06 00 FF | Enable In separate mode |
| | Tele (Variable) | 8x 01 04 06 2p FF | Enable In separate mode |
| | Wide (Variable) | 8x 01 04 06 3p FF | Enable In separate mode |
| Direct | 8x 01 04 46 0p 0q 0r 0s FF | Enable In separate mode | |
| | Stop | 8x 01 04 08 00 FF | |

| Command type | function | command | |
|---------------|------------------|---|--|
| CAM_Focus | Far(Standard) | 8x 01 04 08 02 FF | |
| | Near(Standard) | 8x 01 04 08 03 FF | |
| | Far (Variable) | 8x 01 04 08 2p FF | p=0 (Low) to 7 (High) |
| | Near (Variable) | 8x 01 04 08 3p FF | p=0 (Low) to 7 (High) |
| | Direct | 8x 01 04 48 0p 0q 0r 0s FF | pqrs: Focus Position |
| | Auto Focus | 8x 01 04 38 02 FF | |
| | Manual Focus | 8x 01 04 38 03 FF | |
| | One Push AF | 8x 01 04 18 01 FF | |
| CAM_ZoomFocus | Direct | 8x 01 04 47 0p 0q 0r 0s 0t 0u 0v 0w FF | pqrs: Zoom Position (0(wide)~ 0x4000(tele)) tuvw: Focus Position |
| CAM_WB | Auto | 8x 01 04 35 00 FF | |
| | Indoor | 8x 01 04 35 01 FF | |
| | Outdoor | 8x 01 04 35 02 FF | |
| | OnePush | 8x 01 04 35 03 FF | |
| | ATW | 8x 01 04 35 04 FF | |
| | Manual | 8x 01 04 35 05 FF | |
| | Sodium lamp | 8x 01 04 35 08 FF | |
| | fluorescent | 8x 01 04 35 09 FF | |
| | OnePush Trigger | 8x 01 04 10 05 FF | |
| CAM_RGain | Reset | 8x 01 04 03 00 FF | Manual Control of R Gain |
| | Up | 8x 01 04 03 02 FF | |
| | Down | 8x 01 04 03 03 FF | |
| | Direct | 8x 01 04 43 00 00 0p 0q FF | pq: R Gain (0~0xFF) |
| CAM_Bgain | Reset | 8x 01 04 04 00 FF | Manual Control of B Gain |
| | Up | 8x 01 04 04 02 FF | |
| | Down | 8x 01 04 04 03 FF | |
| | Direct | 8x 01 04 44 00 00 0p 0q FF | pq: B Gain (0-0xFF) |
| CAM_AE | Full Auto | 8x01 04 39 00 FF | Automatic Exposure mode |
| | Manual | 8x 01 04 39 03 FF | Manual Control mode |
| | Shutter Priority | 8x 01 04 39 0A FF | Shutter Priority Automatic Exposure mode |
| | Iris Priority | 8x 01 04 39 0B FF | Iris Priority Automatic Exposure mode |
| | Bright | 8x 01 04 39 0D FF | Bright Mode (Manual control) |
| CAM_Shutter | Reset | 8x 01 04 0A 00 FF | Shutter Setting |
| | Up | 8x 01 04 0A 02 FF | |

| Command type | function | command | |
|--------------------|------------|----------------------------|---|
| | Down | 8x 01 04 0A 03 FF | |
| | Direct | 8x 01 04 4A 00 00 0p 0q FF | pq: Shutter Position (0~0x15) |
| CAM_Iris | Reset | 8x 01 04 0B 00 FF | Iris Setting(0~0xD) |
| | Up | 8x 01 04 0B 02 FF | |
| | Down | 8x 01 04 0B 03 FF | |
| | Direct | 8x 01 04 4B 00 00 0p 0q FF | pq: Iris Position (0~ 0x11) |
| CAM_Gain | Reset | 8x 01 04 0C 00 FF | Gain Setting (0~0x0F) |
| | Up | 8x 01 04 0C 02 FF | |
| | Down | 8x 01 04 0C 03 FF | |
| | Direct | 8x 01 04 0C 00 00 0p 0q FF | pq: Gain Positon (0~0x0E) |
| CAM_Bright | Reset | 8x 01 04 0D 00 FF | Bright Setting |
| | Up | 8x 01 04 0D 02 FF | |
| | Down | 8x 01 04 0D 03 FF | |
| | Direct | 8x 01 04 4D 00 00 0p 0q FF | pq: Bright I Positon (0~0x1B) |
| CAM_WDR | On | 8x 01 04 3D 02 FF | Exposure Compensation ON/OFF |
| | Off | 8x 01 04 3D 03 FF | |
| | Direct | 8x 01 04 D3 pq FF | pq: ExpComp Position (0~0x6) |
| CAM_BackLight(BLC) | On | 8x 01 04 33 02 FF | BackLight On |
| | Off | 8x 01 04 33 03 FF | BackLight Off |
| CAM_Sharpness | Reset | 8x 01 04 02 00 FF | Aperture Control |
| | Up | 8x 01 04 02 02 FF | |
| | Down | 8x 01 04 02 03 FF | |
| | Direct | 8x 01 04 42 00 00 0p 0q FF | pq: Aperture Gain (0~0x0F) |
| CAM_Memory(preset) | Reset | 8x 01 04 3F 00 pp FF | pp: Preset Number(=0 to 127) Corresponds to 0 to 9 on the Remote Commander |
| | Set | 8x 01 04 3F 01 pp FF | |
| | Recall | 8x 01 04 3F 02 pp FF | |
| CAM_LR_Reverse | On | 8x 01 04 61 02 FF | Image Flip Horizontal ON/OFF |
| | Off | 8x 01 04 61 03 FF | |
| CAM_PictureFlip | On | 8x 01 04 66 02 FF | Image Flip Vertical ON/OFF |
| | Off | 8x 01 04 66 03 FF | |
| CAM_RS485Ctl | On | 8x 01 06 A5 02 FF | |
| | Off | 8x 01 06 A5 03 FF | |
| CAM_Saturation | Saturation | 8x 01 04 A1 00 00 0p 0q FF | pq :saturation level 0x00~0x0f |
| CAM_Contrast | Contrast | 8x 01 04 A2 00 00 0p 0q FF | pq :Contrast level 0x00~0x0f |

| Command type | function | command | |
|-----------------------------|------------|----------------------------|--|
| CAM_SpeedByZoom | On | 8x 01 06 A0 02 FF | |
| | Off | 8x 01 06 A0 03 FF | |
| CAM_PTSpeed | PT Speed | 8x 01 04 C1 00 00 0p 0q FF | pp :PT speed 0x05~0x18 |
| CAM_ZoomSpeed | Zoom Speed | 8x 01 04 D1 00 00 0p 0q FF | pp :Zoom speed 0x01~0x07 |
| CAM_ZoomDisplay | On | 8x 01 06 C2 02 FF | |
| | Off | 8x 01 06 C2 03 FF | |
| CAM_IRAddress | IR address | 8x 01 06 D8 0p FF | p:IR address 1~4 |
| CAM_Gamma | Gamma set | 8x 01 04 5B 0p FF | P:Gamma NO. (0~4) |
| CAM_2D Noise Reduction | Direct | 8x 01 04 A5 0p FF | (0~0x01) |
| CAM_3D Noise Reduction | Direct | 8x 01 04 53 0p FF | (0~0x05) |
| FLICK | 50HZ | 8x 01 04 23 01 FF | |
| | 60HZ | 8x 01 04 23 02 FF | |
| | OFF | 8x 01 04 23 00 FF | |
| VideoSystem Set(Telycam) | | 8x 01 06 35 00 pp FF | pp: Video format 1080P60 0x00 1080P50 0x01 1080I60 0x02 1080I50 0x03 1080P30 0x04 1080P25 0x05 720P60 0x06 720P50 0x07 720P30 0x08 720P25 0x09 1080P5994 0x0E 1080I5994 0x0F 1080P2997 0x10 720P5994 0x13 720P2997 0x14 1080P24 0x11 1080P2398 0x12 4K@30 0x15 4K@25 0x16 |
| VideoSystem Set(Sony) | | 8x 01 04 24 72 0p 0q FF | pp: Video format 1080P60 0x2e 1080P50 0x2f 1080I60 0x01 1080I50 0x04 1080P30 0x06 1080P25 0x08 720P60 0x09 720P50 0x0c 720P30 0x0e 720P25 0x11 1080P5994 0x13 1080I5994 0x02 1080P2997 0x07 720P5994 0x0a 720P2997 0x0f 1080P24 0x2a |

| Command type | function | command | |
|--------------------|------------------------|---|---|
| | | | 1080P2398 0x2b 4K@30 0x1D 4K@25 0x1E |
| CAM_IDWrite | | 8x 01 04 22 0p 0q 0r 0s FF | pqrs: Camera ID (=0000 to FFFF) |
| DHCP control | DHCP off | 8x 01 04 AE 00 FF | DHCP off |
| | DHCP on | 8x 01 04 AE 01 FF | DHCP on |
| IP address control | IP set | 8x 01 04 AB 0p 0q 0r 0s 0m 0n 0x 0y FF | Set ip to :pq.rs.mn.xy |
| | Mask set | 8x 01 04 AC 0p 0q 0r 0s 0m 0n 0x 0y FF | Set mask to :pq.rs.mn.xy |
| | Gateway set | 8x 01 04 AD 0p 0q 0r 0s 0m 0n 0x 0y FF | Set gateway to : pq.rs.mn.xy |
| Mainstream | resolution | 8x 01 04 C2 00 0p 0q 0r 0s 0m 0n 0x 0y FF | pqrs : Column(x size) mnxy: Line (y size) only support: 1920*1080 1280*720 3840*2160 1024*576 |
| | rate | 8x 01 04 C2 01 0p 0q 0r 0s 0m 0n 0x 0y FF | pqrsmnxy: bitrate (1024~20480kbps) |
| | Encode Mode | 8x 01 04 C2 02 0p 0q FF | Mode sel:0xpp 0x00:h264 0x01:h265 |
| | Frame Rate | 8x 01 04 C2 03 0p 0q FF | Frame rate:0xpp (15~30) |
| | IDR | 8x 01 04 C2 04 0p 0q FF | IDR Setting:0xpp (5~120) |
| | StreamRateMode | 8x 01 04 C2 05 0p 0q FF | Contor mode:0xpp 0x00:CBR 0x01:VBR |
| Substream | resolution | 8x 01 04 C3 00 0p 0q 0r 0s 0m 0n 0x 0y FF | pqrs : Column(x size) mnxy: Line (y size) only support: 640*360 |
| | rate | 8x 01 04 C3 01 0p 0q 0r 0s 0m 0n 0x 0y FF | pqrsmnxy: bitrate (1024~10240kbps) |
| | Encode Mode | 8x 01 04 C3 02 0p 0q FF | Mode sel:0xpp 0x00:h264 0x01:h265 |
| | Frame Rate | 8x 01 04 C3 03 0p 0q FF | Frame rate:0xpp (15~30) |
| | IDR | 8x 01 04 C3 04 0p 0q FF | IDR Setting:0xpp (5~120) |
| | StreamRateMode | 8x 01 04 C3 05 0p 0q FF | Contor mode:0xpp 0x00:CBR 0x01:VBR |
| Color adjust | Coloradjust OFF | 8x 01 04 B6 00 FF | Color adjust off |
| | Color adjust ON | 8x 01 04 B6 01 FF | Color adjust on |
| | brightness balance OFF | 8x 01 04 B7 00 FF | Keep Brightness |
| | brightness balance ON | 8x 01 04 B7 01 FF | No keep Brightness |
| | Flare red | 8x 01 04 B8 dat FF | Flare mode red value Default is 32 |
| | Flare green | 8x 01 04 B9 dat FF | Flare mode green value Default is 32 |
| | Flare blue | 8x 01 04 BA dat FF | Flare mode blue value Default is 32 |

| Command type | function | command | |
|------------------|------------------|---|--|
| SYS_Menu | Menu On | 8x 01 06 06 02 FF | Turn on the menu |
| | Menu Off | 8x 01 06 06 03 FF | Turn off the menu |
| | Menu Back | 8x 01 06 06 10 FF | Menu step back |
| | Menu Ok | 8x 01 7E 01 02 00 01 FF | Menu ok |
| IR_Receive | On | 8x 01 06 08 02 FF | IR(remote commander)receive ON/OFF |
| | Off | 8x 01 06 08 03 FF | |
| | On/Off | 8x 01 06 08 10 FF | |
| Pan_tiltDrive | Up | 8x 01 06 01 VV WW 03 01 FF | VV: Pan speed 0x01 (low speed) to 0x18 (high speed) WW: Tilt speed 0x01 (low speed) to 0x14 (high speed) YYYY: Pan Position(TBD) ZZZZ: Tilt Position(TBD) |
| | Down | 8x 01 06 01 VV WW 03 02 FF | |
| | Left | 8x 01 06 01 VV WW 01 03 FF | |
| | Right | 8x 01 06 01 VV WW 02 03 FF | |
| | Upleft | 8x 01 06 01 VV WW 01 01 FF | |
| | Upright | 8x 01 06 01 VV WW 02 01 FF | |
| | DownLeft | 8x 01 06 01 VV WW 01 02 FF | |
| | DownRight | 8x 01 06 01 VV WW 02 02 FF | |
| | Stop | 8x 01 06 01 VV WW 03 03 FF | |
| | AbsolutePosition | 8x 01 06 02 VV WW 0Y 0Y 0Y 0Y 0Z 0Z 0Z 0Z FF | |
| | RelativePosition | 8x 01 06 03 VV WW 0Y 0Y 0Y 0Y 0Z 0Z 0Z 0Z FF | |
| | Home | 8x 01 06 04 FF | |
| Reset | 8x 01 06 05 FF | | |
| Pan-tiltLimitSet | Set | 8x 01 06 07 00 0W 0Y 0Y 0Y 0Y 0Z 0Z 0Z 0Z FF | W:1 UpRight 0:DownLeft YYYY: Pan Limit Position(TBD) ZZZZ: Tilt Limit Position(TBD) |
| | Clear | 8x 01 06 07 01 0W 07 0F 0F 0F 07 0F 0F 0F FF | |

Part 3 Camera Inquiry Command

| Command type | command | return | note |
|----------------------|----------------|----------------------|---|
| CAM_PowerInq | 8x 09 04 00 FF | y0 50 02 FF | On |
| | | y0 50 03 FF | Off(Standby) |
| CAM_ZoomPosInq | 8x 09 04 47 FF | y0 50 0p 0q 0r 0s FF | pqrs: Zoom Position |
| CAM_DZoomOnOffInq | 8x 09 04 06 FF | y0 50 0p FF | p 2: ON 3: OFF |
| CAM_DZoomModelInq | 8x 09 04 36 FF | y0 50 0p FF | p 0:combination mode 1:separate mode |
| CAM_DZoomPosInq | 8x 09 04 46 FF | y0 50 0p 0q 0r 0s FF | pqrs: Zoom Position |
| CAM_SpeedByZoomInq | 8x 09 06 A0 FF | y0 50 0p FF | p 2: ON 3: OFF |
| CAM_PTSpeedInq(IR) | 8x 09 04 C1 FF | y0 50 pp FF | pp: 0x05~0x18 |
| CAM_ZoomSpeedInq(IR) | 8x 09 04 D1 FF | y0 50 0p FF | p:0x00~0x07 |
| CAM_FocusModelInq | 8x 09 04 38 FF | y0 50 02 FF | Auto Focus |
| | | y0 50 03 FF | Manual Focus |
| CAM_FocusPosInq | 8x 09 04 48 FF | y0 50 0p 0q 0r 0s FF | pqrs: Focus Position |

| | | | |
|-------------------------|-------------------|-------------------------------------|--|
| CAM_2D_Inq | 8x 09 04 A5 FF | y0 50 03 FF | (0~0x01) p: 0: off 1: on |
| CAM_3D_Inq | 8x 09 04 53 FF | y0 50 03 FF | (0~0x05) p:0:off 1: auto 2~5: noise level |
| CAM_WBModelInq | 8x 09 04 35 FF | y0 50 00 FF | Auto |
| | | y0 50 01 FF | Indoor mode |
| | | y0 50 02 FF | Outdoor mode |
| | | y0 50 03 FF | OnePush mode |
| | | y0 50 04 FF | ATW |
| | | y0 50 05 FF | Manual |
| CAM_RGainInq | 8x 09 04 43 FF | y0 50 00 00 0p 0q FF | pq: R Gain |
| CAM_BGainInq | 8x 09 04 44 FF | y0 50 00 00 0p 0q FF | pq: B Gain |
| CAM_SaturationInq | 8x 09 04 A1 FF | y0 50 00 00 0p 0q FF | pq: saturation |
| CAM_ContrastInq | 8x 09 04 A2 FF | y0 50 00 00 0p 0q FF | pq: contrast |
| CAM_AEModelInq | 8x 09 04 39 FF | y0 50 00 FF | Full Auto |
| | | y0 50 03 FF | Manual |
| | | y0 50 0A FF | Shutter priority |
| | | y0 50 0B FF | Iris priority |
| | | y0 50 0D FF | Bright |
| CAM_FlickerModelInq | 8x 09 04 AA FF | y0 50 0p FF | p 0: OFF 1: 50HZ 2: 60HZ |
| CAM_ShutterPosInq | 8x 09 04 4A FF | y0 50 00 00 0p 0q FF | pq: Shutter Position |
| CAM_IrisPosInq | 8x 09 04 4B FF | y0 50 00 00 0p 0q FF | pq: Iris Position |
| CAM_GainPosInq | 8x 09 04 4C FF | y0 50 00 00 0p 0q FF | pq: Gain Position |
| CAM_BrightPosInq | 8x 09 04 4D FF | y0 50 00 00 0p 0q FF | pq: Bright Position |
| CAM_WDRModelInq | 8x 09 04 3D FF | y0 50 02 FF | On |
| | | y0 50 03 FF | Off |
| CAM_WDRPosInq | 8x 09 04 D3 FF | y0 50 0p FF | p: WDR Position |
| CAM_ApertureInq | 8x 09 04 42 FF | y0 50 00 00 0p 0q FF | pq: Aperture Gain |
| CAM_PresetExistInq | 8x 09 04 3F pp FF | y0 50 0q FF | pp: Memory number q: 1=preset exist 0=preset not saved |
| SYS_MenuModelInq | 8x 09 06 06 FF | y0 50 02 FF | On |
| | | y0 50 03 FF | Off |
| CAM_LR_ReverseInq | 8x 09 04 61 FF | y0 50 02 FF | On |
| | | y0 50 03 FF | Off |
| CAM_PictureFlipInq | 8x 09 04 66 FF | y0 50 02 FF | On |
| | | y0 50 03 FF | Off |
| CAM_IDInq | 8x 09 04 22 FF | y0 50 0p 0q 0r 0s FF | pqrs: Camera ID |
| CAM_DHCPInq | 8x 09 04 AE FF | y0 50 pp FF | |
| CAM_IPInq | 8x 09 04 AB FF | y0 50 0p 0p 0q 0q 0r 0r 0s 0s FF | |
| CAM_MASKInq | 8x 09 04 AC FF | y0 50 0p 0p 0q 0q 0r 0r 0s 0s FF | |
| CAM_GATEWAYInq | 8x 09 04 AD FF | y0 50 0p 0p 0q 0q 0r 0r 0s 0s FF | |
| CAM_FlareModelInq | 8x 09 04 B6 FF | y0 50 pp FF | |
| CAM_FlareBrightModelInq | 8x 09 04 B7 FF | y0 50 pp FF | |
| CAM_FlareRed | 8x 09 04 B8 FF | y0 50 pp FF | |
| CAM_FlareGreen | 8x 09 04 B9 FF | y0 50 pp FF | |
| CAM_FlareBlue | 8x 09 04 BA FF | y0 50 pp FF | |
| CAM_VersionInq | 8x 09 00 02 FF | y0 50 ab cd | |

| | | mn pq rs tu vw FF | |
|-------------------------|-------------------|-------------------------------------|--|
| VideoSystemInq(Telycam) | 8x 09 06 23 FF | y0 50 pp FF | pp: Video format |
| VideoSystemInq(Sony) | 8x 09 04 24 72 FF | y0 50 0p 0p FF | pp: Video format |
| IR_Transfer | 8x 09 06 1A FF | y0 50 02 FF | On |
| | | y0 50 03 FF | Off |
| IR_Receive | 8x 09 06 08 FF | y0 50 02 FF | On |
| | | y0 50 03 FF | Off |
| Pan-tiltMaxSpeedInq | 8x 09 06 11 FF | y0 50 ww zz FF | ww: PanMaxSpeed zz: Tilt Max Speed |
| Pan-tiltPosInq | 8x 09 06 12 FF | y0 50 0w 0w 0w 0w 0z 0z 0z 0z FF | www: PanPosition zzzz: Tilt Position |
| MainstreamResolutionInq | 8x 09 04 C2 00 FF | y0 50 0p 0q 0r 0s 0m 0n 0x 0y FF | pqrs : Column(x size) mnxy: Line (y size) only support: 1920*1080 、 1280*720、 3840*2160 、 1024*576 |
| MainstreamRateInq | 8x 09 04 C2 01 FF | y0 50 0p 0q 0r 0s 0m 0n 0x 0y FF | pqrsmnxy: bitrate (1024~20480) |
| MainEncodeModelInq | 8x 09 04 C2 02 FF | y0 50 pp FF | Mode sel:0xpp 0x00:h264 0x01: h265 |
| MainFrameRateInq | 8x 09 04 C2 03 FF | y0 50 pp FF | Frame rate:0xpp (15~30) |
| MainIDRInq | 8x 09 04 C2 04 FF | y0 50 pp FF | IDR Setting:0xpp (5~120) |
| MainStreamRateModelInq | 8x 09 04 C2 05 FF | y0 50 pp FF | Contor mode:0xpp 0x00:CBR 0x01:VBR |
| SubstreamResolutionInq | 8x 09 04 C3 00 FF | y0 50 0p 0q 0r 0s 0m 0n 0x 0y FF | pqrs : Column(x size) mnxy: Line (y size) only support: 640*360 |
| SubstreamRateInq | 8x 09 04 C3 01 FF | y0 50 0p 0q 0r 0s 0m 0n 0x 0y FF | pqrsmnxy: bitrate (1024~20480 kbps) |
| SubEncodeModelInq | 8x 09 04 C3 02 FF | y0 50 pp FF | Mode sel:0xpp 0x00:h264 0x01: h265 |
| SubFrameRateInq | 8x 09 04 C3 03 FF | y0 50 pp FF | Frame rate:0xpp (15~30) |
| SubIDRInq | 8x 09 04 C3 04 FF | y0 50 pp FF | IDR Setting:0xpp (5~120) |
| SubStreamRateModelInq | 8x 09 04 C3 05 FF | y0 50 pp FF | Contor mode:0xpp 0x00:CBR 0x01:VBR |

Note: **[x]** means the camera address ; **[y]** = **[x + 8]** .

VISCA PAN TILT ABSOLUTE POSITION VALUE

| Pan Angle | VISCA Value | Tilt Angle | VISCA Value |
|-----------|-------------|------------|-------------|
| -170 | 0xF670 | -30 | 0xFE50 |
| -135 | 0xF868 | 0 | 0x0000 |
| -90 | 0xFAF0 | 30 | 0x01B0 |
| -45 | 0xFD78 | 60 | 0x0360 |
| 0 | 0x0000 | 90 | 0x510 |
| 45 | 0x0288 | | |
| 90 | 0x0510 | | |
| 135 | 0x0798 | | |
| 170 | 0x0990 | | |

VISCA PAN TILT SPEED VALUE

| Pan(Degree/Second) | | Pan(Degree/Second)) | |
|--------------------|-----|---------------------|-----|
| 0 | 0.3 | 0 | 0.3 |
| 1 | 1 | 1 | 1 |
| 2 | 1.5 | 2 | 1.5 |
| 3 | 2.2 | 3 | 2.2 |
| 4 | 2.4 | 4 | 3.6 |
| 5 | 2.6 | 5 | 4.7 |
| 6 | 2.8 | 6 | 6 |
| 7 | 3.0 | 7 | 8 |
| 8 | 3.2 | 8 | 10 |
| 9 | 3.4 | 9 | 12 |
| 10 | 3.8 | 10 | 15 |
| 11 | 4.5 | 11 | 18 |
| 12 | 6 | 12 | 23 |
| 13 | 9 | 13 | 30 |
| 14 | 15 | 14 | 39 |
| 15 | 19 | 15 | 48 |
| 16 | 25 | 16 | 59 |
| 17 | 32 | 17 | 69 |
| 18 | 38 | 18 | 80 |
| 19 | 45 | | |
| 20 | 58 | | |
| 21 | 75 | | |
| 22 | 88 | | |
| 23 | 105 | | |
| 24 | 120 | | |

PELCO-D Protocol Command List

| Function | Byte1 | Byte2 | Byte3 | Byte4 | Byte5 | Byte6 | Byte7 |
|------------------------------|-------|---------|-------|-------|-----------------|----------------|-------|
| Up | 0xFF | Address | 0x00 | 0x08 | Pan Speed | Tilt Speed | SUM |
| Down | 0xFF | Address | 0x00 | 0x10 | Pan Speed | Tilt Speed | SUM |
| Left | 0xFF | Address | 0x00 | 0x04 | Pan Speed | Tilt Speed | SUM |
| Right | 0xFF | Address | 0x00 | 0x02 | Pan Speed | Tilt Speed | SUM |
| Upleft | 0xFF | Address | 0x00 | 0x0C | Pan Speed | Tilt Speed | SUM |
| Upright | 0xFF | Address | 0x00 | 0x0A | Pan Speed | Tilt Speed | SUM |
| DownLeft | 0xFF | Address | 0x00 | 0x14 | Pan Speed | Tilt Speed | SUM |
| DownRight | 0xFF | Address | 0x00 | 0x12 | Pan Speed | Tilt Speed | SUM |
| Zoom In | 0xFF | Address | 0x00 | 0x20 | 0x00 | 0x00 | SUM |
| Zoom Out | 0xFF | Address | 0x00 | 0x40 | 0x00 | 0x00 | SUM |
| Focus Far | 0xFF | Address | 0x00 | 0x80 | 0x00 | 0x00 | SUM |
| Focus Near | 0xFF | Address | 0x01 | 0x00 | 0x00 | 0x00 | SUM |
| Set Preset | 0xFF | Address | 0x00 | 0x03 | 0x00 | Preset ID | SUM |
| Stop | 0xFF | Address | 0x00 | 0x00 | Pan Speed | Tilt Speed | SUM |
| Clear Preset | 0Xff | Address | 0x00 | 0x05 | 0x00 | Preset ID | SUM |
| Call Preset | 0Xff | Address | 0x00 | 0x07 | 0x00 | Preset ID | SUM |
| Query Pan Position | 0Xff | Address | 0x00 | 0x51 | 0x00 | 0x00 | SUM |
| Query Pan Position Response | 0Xff | Address | 0x00 | 0x59 | Value High Byte | Value Low Byte | SUM |
| Query Tilt Position | 0Xff | Address | 0x00 | 0x53 | 0x00 | 0x00 | SUM |
| Query Tilt Position Response | 0Xff | Address | 0x00 | 0x5B | Value High Byte | Value Low Byte | SUM |
| Query Zoom Position | 0Xff | Address | 0x00 | 0x55 | 0x00 | 0x00 | SUM |
| Query Zoom Position Response | 0Xff | Address | 0x00 | 0x5D | Value High Byte | Value Low Byte | SUM |

PELCO-P Protocol Command List

| Function | Byte1 | Byte2 | Byte3 | Byte4 | Byte5 | Byte6 | Byte7 | Byte8 |
|------------------------------|-------|---------|-------|-------|-----------------|----------------|-------|-------|
| Up | 0xA0 | Address | 0x00 | 0x08 | Pan Speed | Tilt Speed | 0xAF | XOR |
| Down | 0xA0 | Address | 0x00 | 0x10 | Pan Speed | Tilt Speed | 0xAF | XOR |
| Left | 0xA0 | Address | 0x00 | 0x04 | Pan Speed | Tilt Speed | 0xAF | XOR |
| Right | 0xA0 | Address | 0x00 | 0x02 | Pan Speed | Tilt Speed | 0xAF | XOR |
| Upleft | 0xA0 | Address | 0x00 | 0x0C | Pan Speed | Tilt Speed | 0xAF | XOR |
| Upright | 0xA0 | Address | 0x00 | 0x0A | Pan Speed | Tilt Speed | 0xAF | XOR |
| DownLeft | 0xA0 | Address | 0x00 | 0x14 | Pan Speed | Tilt Speed | 0xAF | XOR |
| DownRight | 0xA0 | Address | 0x00 | 0x12 | Pan Speed | Tilt Speed | 0xAF | XOR |
| Zoom In | 0xA0 | Address | 0x00 | 0x20 | 0x00 | 0x00 | 0xAF | XOR |
| Zoom Out | 0xA0 | Address | 0x00 | 0x40 | 0x00 | 0x00 | 0xAF | XOR |
| Focus Far | 0xA0 | Address | 0x00 | 0x80 | 0x00 | 0x00 | 0xAF | XOR |
| Focus Near | 0xA0 | Address | 0x01 | 0x00 | 0x00 | 0x00 | 0xAF | XOR |
| Stop | 0xA0 | Address | 0x00 | 0x00 | Pan Speed | Tilt Speed | 0xAF | XOR |
| Set Preset | 0xA0 | Address | 0x00 | 0x03 | 0x00 | Preset ID | 0xAF | XOR |
| Clear Preset | 0xA0 | Address | 0x00 | 0x05 | 0x00 | Preset ID | 0xAF | XOR |
| Call Preset | 0xA0 | Address | 0x00 | 0x07 | 0x00 | Preset ID | 0xAF | XOR |
| Query Pan Position | 0xA0 | Address | 0x00 | 0x51 | 0x00 | 0x00 | 0xAF | XOR |
| Query Pan Position Response | 0xA0 | Address | 0x00 | 0x59 | Value High Byte | Value Low Byte | 0xAF | XOR |
| Query Tilt Position | 0xA0 | Address | 0x00 | 0x53 | 0x00 | 0x00 | 0xAF | XOR |
| Query Tilt Position Response | 0xA0 | Address | 0x00 | 0x5B | Value High Byte | Value Low Byte | 0xAF | XOR |
| Query Zoom Position | 0xA0 | Address | 0x00 | 0x55 | 0x00 | 0x00 | 0xAF | XOR |
| Query Zoom Position Response | 0xA0 | Address | 0x00 | 0x5D | Value High Byte | Value Low Byte | 0xAF | XOR |

OSD MENU

1. Under working mode, press the MENU key on the IR remote controller, to enter the OSD menu as bellow:

| MENU | |
|----------|----------------------|
| SYSTEM | PROTOCOL < VISCA > |
| EXPOSURE | ADDRESS < 001 > |
| IMAGE | BAUDRATE < 9600 > |
| QUALITY | PTL LOCK < OFF > |
| PTZ | RS485 < ON > |
| FORMAT | VISCA < OVER ALL > |
| IP | LANGUAGE < ENGLISH > |
| RESET | |
| INFO | |

2. After enter the main menu, use the navigate UP/DOWN key to select the main menu. Once been selected, the main menu will change to blue background, and the right side will show all sub menu options.

3. Press the navigate RIGHT key to enter sub menu; use UP/DONW key to select the sub menu; use LEFT/RIGHT key to select parameter.

4. Press the MENU key again to return to previous menu. Press the MENU key continuously to exit the OSD menu.

5. OSD Menu Setting List

| | | | |
|--------|-----------|--|-------------------|
| SYSTEM | PROTOCOL | Optional item: VISCA、PLC.P、PLC.D | Default: VISCA |
| | ADDRESS | VISCA:1~7 PLC.P/PLC.D:1~255 | Default: 1 |
| | BAUD RATE | Optional item:2400、4800、9600、115200 | Default: 9600 |
| | PTL LOCK | Protocol lock: once set, above protocol setting will be locked | Default: OFF |
| | RS485 | RS485 ON/OFF | Default: ON |
| | VISCA | Optional Item: OVER ALL、OVER IP、OVER COM | Default: OVER ALL |
| | LANGUAGE | Optional Item: Chinese、English | Default: English |

| | | | |
|----------|---------------|---|---------------|
| EXPOSURE | EXPOSURE MODE | AUTO、MANUAL、SHUTTER、IRIS、BRIGHT | Default: AUTO |
| | SHUTTER | Shutter speed: 1/30~1/10000, only valid under MANUAL and SHUTTER mode | Default: AUTO |
| | IRIS | Iris setting: CLOSE~F1.8, only valid under MANUAL and IRIS mode | Default: AUTO |
| | GAIN | Gain setting: 0dB~30dB, only valid under MANUAL mode | Default: AUTO |
| | EBRIGHT | Bright setting: 0~27, only valid under BRIGHT priority mode. | Default: AUTO |
| | BRIGHT | 0~15 | Default: 8 |
| | WD MODE | ON/OFF | Default: OFF |
| | WD LEVEL | WDR Level | Default: 1 |
| BLC | ON/OFF | Default: OFF | |

| | | | |
|--|---------|---|--------------|
| | WB MODE | Optional: ATW、MANUAL、AUTO、INDOOR、OUTDOOR、PUSH | Default: ATW |
|--|---------|---|--------------|

| | | | |
|-------|--------|--|---------------|
| IMAGE | R GAIN | Red gain level: 0~255, only valid under manual white balance mode | Default: AUTO |
| | B GAIN | Blue gain level: 0~255, only valid under manual white balance mode | Default: AUTO |
| | FLICK | Anti-Flicker setting: 50/60HZ, to reduce the video flicker | Default: 50HZ |
| | DZOOM | ON/OFF | Default: OFF |
| | FOCUS | Select focus mode | Default: AUTO |

| | | | |
|---------|----------------|--|-----------------|
| QUALITY | 2D NR | 2D noise reduction: the bigger value is, the less noise on image is, the lower resolution is | Default: OFF |
| | 3D NR | 3D noise reduction: OFF/AUTO/0~4, the bigger value is, the less motion noise on image is. High value will cause image smear. | Default: AUTO |
| | SHARPNESS | Sharpness setting: 0~15, the higher value is, edge of the image will be sharpen | Default: 3 |
| | CONTRAST | Set contrast level | Default: 8 |
| | SATURATION | Set saturation. | Default: 8 |
| | GAMMA | Select gamma level | Default: 0 |
| | AF SENSITIVITY | Optional: LOW/NORMAL/HIGH | Default: NORMAL |

| | | | |
|-----|----------|--|-----------------|
| PTZ | SPEEDBYZ | SpeedByZoom: proportional speed, the bigger the zoom is, the slower the speed is | Default: ON |
| | FLIP.HOR | Flip horizontal | Default: OFF |
| | FLIP VER | Flip vertical | Default: OFF |
| | PT SPD | Pan Tilt speed | Default: 18 |
| | ZOOM SPD | Zoom speed | Default: 5 |
| | MENU MIR | Optional Item: NORMAL、MIRROR | Default: NORMAL |
| | PRE FRZ | Open/Close Video Freeze when running presets | Default: OFF |

| | | | |
|--------|--------------|--------------|--|
| FORMAT | 3840*2160P30 | 3840*2160P25 | <p>After selecting the system, press OK to switch the system.</p> <p>If it is the currently selected system, it will not be activated.</p> |
| | 1080P59.94 | 1080P50 | |
| | 1080I59.94 | 1080I50 | |
| | 1080P29.97 | 1080P25 | |
| | 720P59.94 | 720P50 | |
| | 720P29.97 | 720P25 | |

| | | | |
|--|---------|---------|--|
| | 1080P60 | 1080P30 | |
| | 720P60 | 720P30 | |
| | 1080I60 | 1080P24 | |

| | | | |
|----|--------------|--------------------|--|
| IP | DHCP | ON/OFF | Using up/down/left/right navigation button to select item to set, and using number button to set parameter. Press menu button to return. |
| | IP | 192.168.001.188 | |
| | MASK | 255.255.255.000 | |
| | GW (Gateway) | 192.168.001.001 | |
| | MAIN | Default: 1920*1080 | |
| | BITRATE | Default: 04096k | |
| | SUB | Default: 640*360 | |
| | BITRATE | Default: 02048k | |

| | | |
|-------|-----------|--|
| RESET | SYS RESET | Reset communication parameter to default |
| | CAM RESET | Reset camera parameter to default |
| | PT RESET | Reset pan/tilt parameter to default |
| | ALL RESET | Reset all parameter to default |

| | | |
|------|-----------|------------------------------------|
| INFO | IR ADDR | Camera IR control address |
| | USB | USB firmware version |
| | CLIENT | Default client end protocol: VISCA |
| | MODEL NO. | Model number |
| | ARM VER | ARM firmware version |
| | FPGA VER | FPGA firmware version |
| | CAM VER | Camera version |
| | RELEASE | Software release date |

Set IP Address in Menu

In order to facilitate customer debugging, the camera has the support menu to set IP address. The specific methods are as follows:

1. Press "MENU" to open the menu interface, select "network parameters" in the menu to call up the IP setting interface:



2. Right click the remote control to enter the IP setting interface, and select the parameters to be set by using the navigation up and down keys, and then select the IP address, mask, gateway:
3. Short press the number key to set the corresponding parameters. After setting the current parameters, press the "MENU" key again to complete the current parameter setting;
4. To exit the menu, just press the "MENU" key again.

UVC CONTROL

1. Only run the client software after the USB3.0 camera has completed self-configuration (the IR indicator in blue color and will not flash); otherwise may cause black video issue.
2. Make sure the USB3.0 camera is recognized by the PC Device Manager.
3. Make sure the interval of video format switching more than 3 seconds, otherwise black video maybe caused.
4. Make sure the interval of control command sending from the server (via USB) to the camera no less than 250ms.
5. Support standard UVC interface.

| | |
|--------------------------------------|---------------------------------------|
| PU_BRIGHTNESS_CONTROL | 81 01 04 4d 00 00 0p 0q FF |
| PU_CONTRAST_CONTROL | 81 01 04 A2 00 00 0p 0q FF |
| PU_SATURATION_CONTROL | 81 01 04 A1 00 00 0p 0q FF |
| PU_SHARPNESS_CONTROL | 8x 01 04 42 00 00 0p 0q FF |
| PU_GAMMA_CONTROL | 8x 01 04 5B 0p FF |
| PU_WHITE_BALANCE_TEMPERATURE_CONTROL | 8x 01 04 35 0X FF |
| PU_BACKLIGHT_COMPENSATION_CONTROL | 81 01 04 33 02/03 FF |
| PU_POWER_LINE_FREQUENCY_CONTROL | 8x 01 04 AA 00/01/02 FF |
| CT_ZOOM_ABSOLUTE_CONTROL | 8x 01 04 47 0p 0q 0r 0s FF |
| CT_PANTILT_ABSOLUTE_CONTROL | 8x 01 06 02 VV WW 0Y 0Y 0Y 0Z 0Z 0Z F |
| CT_PANTILT_RELATIVE_CONTROL | 8x 01 06 01 pp qq rr ss FF |
| CT_ZOOM_RELATIVE_CONTROL | 8x 01 04 07 pp FF |

WEB SETTING

It is not necessary to install additional video player plug-in to preview the local screen on the web interface. At the same time, the browser can call Flash Player to preview the local video.

The web interface supports Google Chrome, Firefox, IE, Safari, Opera, 360, QQ and other browsers, adaptability is very good.

If you need to use Flash Player to play, please install Flash Player according to the following procedure. If no Flash Player is installed on PC, the video decoder provided by browser will be used by default to decode and display the video. Please note that IE browser does not support decoding by non Flash Player . If you can't preview video with flash player, please use Edge and Chrome, Firefox, Safari etc.

1. Download and install Flash Player

When visit IP camera via Internet Explore browser the first time, need to install Flash Player, we suggest user download it from flash official website to get latest version:

<https://www.flash.cn/english>

after installation, we will be able to see bellow via PC's Programs and Features Control Panel:



2. Login

Run browser, input IP address(**defaulted IP address is 192.168.1.188**), to enter login interface, can select Language (Chinese or English), input admin and password to login as following:

(Default admin: admin Default password: admin)

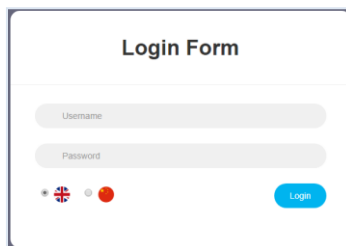

3. Real-time Preview:

If you are log in web interface first time, there maybe show up a mistake notice as bellow, the reason is the explorer prevent the web interface to run Flash Player, what we need to do is to enter explorer setting, to set it allow to use Flash Player.

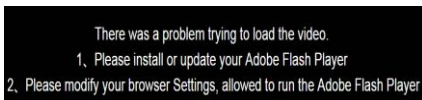

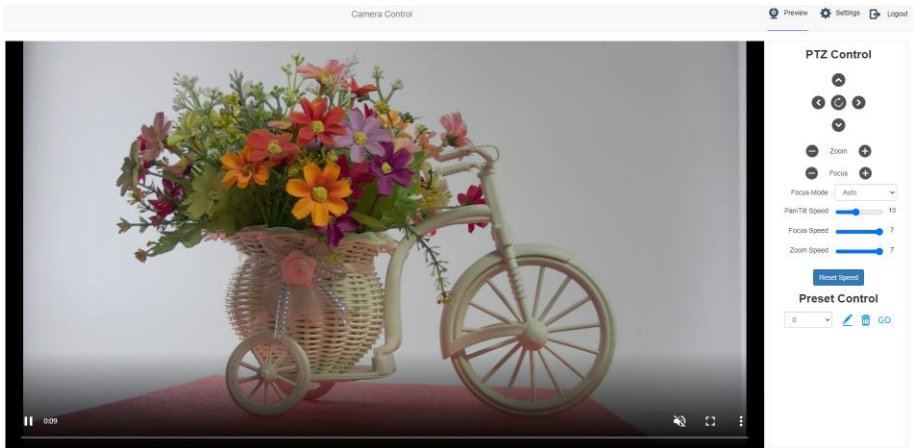

Preview interface as above image, on the right side, there are options to control camera pan, tilt, zoom, focus, presets, focus speed, zoom speed can be set. On the top of the image, main stream and sub stream preview can be selected, image width&height rate can be selected, and full size view can be selected.

4. Parameter Setting

Click “Setting” to enter into parameter setting interface as following:

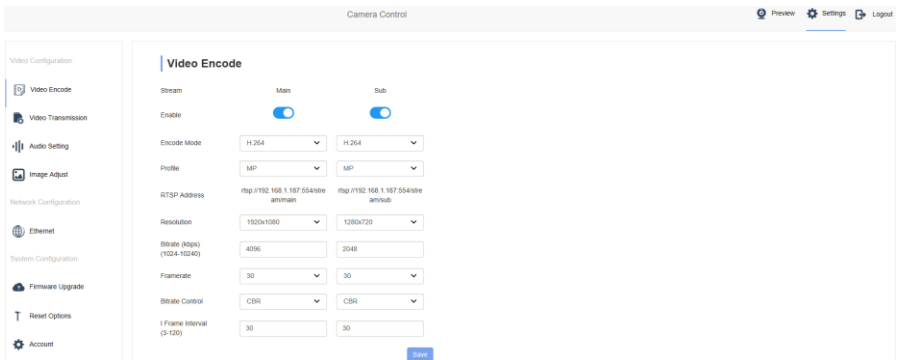

“Video Encode”: can set image encode mode, main stream and sub stream resolution/bit rate/frame rate, bit rate control way, and I frame interval etc as above image

Video Encode

| Stream | Main | Sub |
|--------------------------------|--|---|
| Enable | <input checked="" type="checkbox"/> | <input checked="" type="checkbox"/> |
| Encode Mode | <input type="text" value="H.264"/> | <input type="text" value="H.264"/> |
| Profile | <input type="text" value="MP"/> | <input type="text" value="MP"/> |
| RTSP Address | <input type="text" value="rtsp://192.168.1.187:554/streams/main"/> | <input type="text" value="rtsp://192.168.1.187:554/streams/sub"/> |
| Resolution | <input type="text" value="1920x1080"/> | <input type="text" value="1280x720"/> |
| Bitrate (kbps) (1024-10240) | <input type="text" value="4096"/> | <input type="text" value="2048"/> |
| Framerate | <input type="text" value="30"/> | <input type="text" value="30"/> |
| Bitrate Control | <input type="text" value="CBR"/> | <input type="text" value="CBR"/> |
| I Frame Interval (3-120) | <input type="text" value="30"/> | <input type="text" value="30"/> |

"video Transmission":RTMP settings are available, as shown in the following figure:

RTMP Setting

| Stream | Main | Sub |
|--------------|--|--|
| Enable | <input type="checkbox"/> <input checked="" type="checkbox"/> | <input type="checkbox"/> <input checked="" type="checkbox"/> |
| RTMP Address | <input type="text"/> | <input type="text"/> |

"Image Parameter" can set focus, exposure, white balance, image, image quality, noise-reduction, as following picture.

Image Adjust

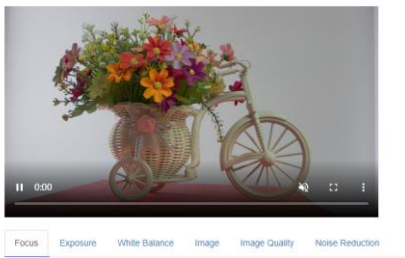

Focus Exposure White Balance Image Image Quality Noise Reduction

Focus Mode

Digital Zoom

Focus including focus mode, default focal distance, digital zoom etc.

Focus Exposure White Balance Image Image Quality Noise Reduction

Focus Mode

Digital Zoom

Exposure includes exposure mode, shutter speed, gain, iris, brightness, and anti-flicker.

White Balance includes white balance mode, red gain, blue gain.

Image includes mirror, flip, backlight compensation, Gamma, WDR(wide dynamic range).

Image Quality includes brightness, sharpness, contrast, saturation.

Noise reduction includes 2D/3D reduction. There is on/off option for 2D, and off/auto/1~4 six options.

“Ethernet” includes DHCP mode, IP address, Netmask, Gateway, Http Port, RTSP Port, Visca Over IP. Default parameter as

following:

| | | | | | |
|------------|---------------|-----------|-------------|---------------|-------|
| DHCP | OFF | Gateway | 192.168.1.1 | RTSP Port | 554 |
| IP address | 192.168.1.188 | DNS | 192.168.1.1 | Visca Over IP | 52381 |
| Netmask | 255.255.255.0 | HTTP Port | 80 | | |

“Firmware upgrade”: it is for camera program upgrade, currently only for ISP part update. How to update:

As following picture, click “clicking to upload file” icon, open dialog box, select to open the file, and click “upgrade” to start.

DO NOT power off or do other operation when upgrading, reboot the camera after 5 min when upgrade finished.

Then login web end to select “reset all” to reset the camera completely.

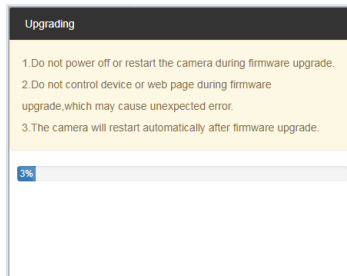

Reset to default : reset the camera to default setting

Reset simply: reset camera image parameter

Reset Completelyall: reset camera Ethernet and image parameter, language and protocol will not be reset.

Reboot: Reboot ISP part of camera

Reset Options

Reset

Reset image settings to their default values.

Reset/Reboot

Reset all camera settings to their default values and reboot

Reboot

Account Setting: is used for setting camera account and password

Input the account firstly, then input same password twice, click set to finish

Please remember account and password, otherwise you may be not able to login.

Account Settings

Account

Password

Confirm Password

Save

VIEW RTSP VIDEO VIA VLC

Default RTSP main streaming address: rtsp://192.168.1.188/stream/main

Default RTSP sub streaming address: rtsp://192.168.1.188/stream/sub

Default RTMP main streaming address: rtmp://192.168.1.188:1935/app/rtmpstream0

Default RTMP sub streaming address: rtmp://192.168.1.188:1935/app/rtmpstream1

1, Run VLC Media Player.

2, Media->network stream, to enter into "open media" interface.

3, Input RTSP address in URL as following:

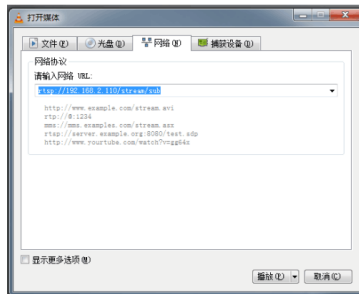

4, Click play to view the real time image.

Note: If there is much image lag, select "more option" to enter into following setting, change buffer time smaller (VLC default buffer time is 1000ms).



VISCA OVER IP

VISCA over IP means VISCA protocol transmit via IP, to reduce RS232/RS485 cable layout (the controller must support IP communication function)

Communication port spec:

- Control port: RJ45 Gigabit LAN
- IP protocol: IPv4
- Transmit protocol: UDP
- IP address: set via web end or OSD menu
- Port address: 52381
- Confirm send/transmission control: depend on applied program
- Applied range: in the same segment, not suitable for bridge network
- Turn on camera: In the menu, set VISCA option to OVER IP

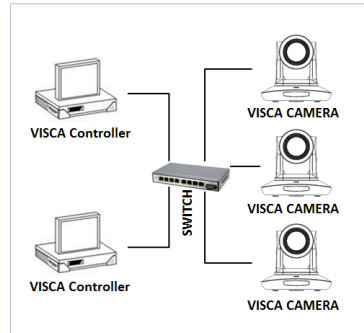

How to use VISCA over IP

VISCA Command

It means commands from controller to peripheral equipment, when peripheral equipment receives commands, then return ACK. When commands executed, will return complete message.

For different commands, camera will return different message.

VISCA Inquiry

It means inquiry from controller to peripheral equipment when peripheral equipment receives this kind of commands, it will return required message.

VISCA Reply

It means ACK, complete message, reply or error reply, it is sent from peripheral equipment to controller.

Command format: the following is message head and valid message format.

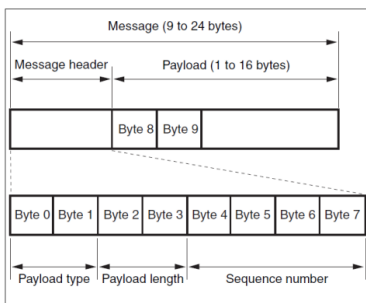

Note: LAN output way is big-endian, LSB is in the front.

Payload type:

Data definition as following:

| Name | Value (Byte 0) | Value (Byte 0) | Value (Byte 0) |
|------------------------------|----------------|----------------|--|
| VISCA command | 0x01 | 0x00 | Stores the VISCA command. |
| VISCA inquiry | 0x01 | 0x10 | Stores the VISCA inquiry. |
| VISCA reply | 0x01 | 0x11 | Stores the reply for the VISCA command and VISCA inquiry, or VISCA device setting command. |
| VISCA device setting command | 0x01 | 0x20 | Stores the VISCA device setting command. |
| Control command | 0x02 | 0x00 | Stores the control command. |
| Control reply | 0x02 | 0x01 | Stores the reply for the control command. |

Payload length

Valid data length in Payload (1~16), is command length.

For example, when valid data length is 16 byte

Byte 2 : 0x00

Byte 3 : 0x10

Controller will save sequence number of each command, when one command sent, the sequence number of the command will add 1, when the sequence number becomes the max value, it will change to 0 for next time. The peripheral equipment will save sequence number of each command, and return the sequence number to the controller.

Payload

According to Payload type, the following data will be saved.

- VISCA command
Save VISCA command packet
- VISCA inquiry
Save VISCA message packet
- VISCA reply
Save VISCA return packet
- VISCA device setting command
Save VISCA equipment setting command packet.
- Control command
The following data is saved in control command payload

| Name | Value | Description |
|-------|--------|--|
| RESET | 0x01 | Resets the sequence number to 0. The value that was set as the sequence number is ignored. |
| ERROR | 0x0Fyy | yy=01:Abnormality in the sequence number. |
| | | yy=02:Abnormality in the message(message type). |

- Controlled reply

The following data is saved in return command payload of control command.

| Message | Value | Description |
|---------|-------|------------------|
| ACK | 0x01 | Reply for RESET. |

Delivery confirmation

VISCA over IP uses UDP as transmission communication protocol, UDP communication message transmission is not stable, it is necessary to confirm delivery and resent in application.

Generally, when controller sends a command to peripheral equipment, controller will wait for the return message then send the next command, we can detect and confirm if the peripheral equipment receive the commands from return message's lag time.

If controller shows it is overtime, it is regarded as error transmission.

If controller shows it is overtime, resend the commands to check peripheral's status, resend command sequence number is same as last command, the following chart list the received message and status after resending the commands.

| Lost message | Received message for retransmission | Status after retransmission | Correspondence after retransmission |
|---|---|---|--|
| Command | ACK message | Command is performed by retransmission. | Continue processing. |
| Completion message For the command | ERROR(Abnormality in the sequence number.) | Command has been performed. If only the ACK message is lost, the completion message returns. | If the result by the completion message is needed, retransmit by updating the sequence number. |
| Completion message for the command | ERROR(Abnormality in the sequence number.) | Command has been performed. | If the result by the completion message is needed, retransmit by updating the sequence number. |
| Inquiry | Reply message | Inquiry is performed by retransmission. | Continue processing. |
| Reply message for the inquiry | ERROR(Abnormality in the sequence number.) | Inquiry has been performed. | If the result by the reply message is needed, retransmit by updating the sequence number. |
| Error message | Error message | Command is not performed. If the error cause eliminates, normal reply is return(ACK, reply message) | Eliminate the error cause. If normal reply returns, continue processing. |
| Inquiry of the VISCA device setting command | Reply message of the VISCA device setting command | Inquiry has been performed by retransmission. | Continue processing. |
| Reply message of the VISCA device setting command | ERROR(Abnormality in the sequence number.) | Inquiry has been performed. | If the result by the reply message is needed, retransmit by updating the sequence number. |

Sequence chart as following

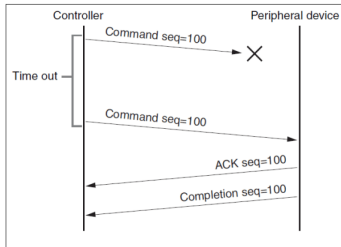

Sequence chart when command lost

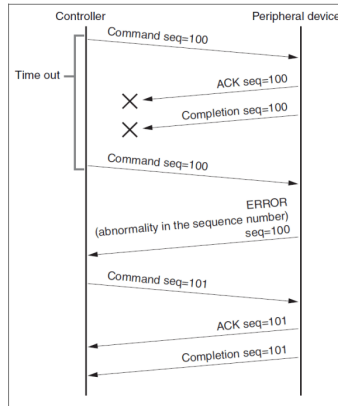

Sequence chart when returned message lost

Note: Do not set IP address, subnet mask, gateway parameter in VISCA over IP command, otherwise, it will cause network breaks off. Due to change these parameter, network will be in off status.

