



CVW Beamlink-Quad

4TX-to-1RX Wireless HD Video Transmission System



EU Environmental Protection

Waste electrical products should not be disposed of with household waste. Please recycle where facilities exist. Check with you local authority or retailer for recycling advice.



User Manual

This user manual applies to:

Transmitter: 7060

Receiver: 3060

User Manual V1.0

Contents

About the User Manual.....	01
Product Features.....	01
Brief introduction.....	01
Packing List.....	02
Structure & Interface.....	03
Wireless HD Transmitter 7060.....	03
Wireless HD Receiver 3060.....	05
Product Installation.....	07
Wireless HD Transmitter 7060.....	07
Wireless HD Receiver 3060.....	09
OLED Display Description.....	14
Functional Instructions.....	16
Wireless Software Upgrade.....	21
Troubleshooting.....	24
Precautions.....	25

Thank you for choosing CVW's professional wireless HD audio and video transmission product. Read the following precautions carefully before using this product:

- * Do not use this product for a long time in the sun or dusty place.
- * Be sure to use this product within the temperature and humidity ranges.
- * Do not operate the product under vibration or strong magnetic fields.
- * Do not put conductive materials in the product vents.
- * Do not open the product yourself without the guidance of our professionals.
- * Before power-on, make sure that the adapter input voltage is AC110V-220V, and that the output voltage and current meet the product specifications.
- * Before power-on, make sure that the antenna is installed.
- * This product is a 5GHz WIFI device. When there are devices with the same frequency around, there may be mutual interference. In this case, solve the problem by switching the frequency channel of the product.

Special Precautions

When installing the machine with the double-thread screw supplied with the product, tighten the product with the fastening screw plate. Do not hold the machine for rotary tightening to prevent the screw from being unable to be removed from the machine.

The RS232 and Tally function interfaces of this product are non-standard physical interfaces. If you need this function, communicate with the sales staff.

About the User Manual

This Manual details the product specifications, instructions for use, precautions, and troubleshooting. Read the Manual carefully before using the product. If you have any questions or difficulties in using this product, contact the company or the seller in time.

Product Features

BeamLink Quad is a set of 4TX-to-1RX full-HD audio and video wireless transmission system. The 4 video channel transmission shares one wireless channel and supports the highest video resolution up to 1080P/60Hz. This system is based on 5G wireless network technology for transmission, along with advanced 4x4 MIMO and Beam-Forming technology. Image processing is performed using H.264 coding-decoding technology, and the video quality is sharp and the latency is lower.

Brief Introduction

High-quality and ultra low latency

This product supports HD-SDI&3G-SDI input and output as well as HDMI full-HD input and output, with the highest resolution of 1080P/60Hz. With the use of H.264 coding-decoding technology with high compression ratio and high definition, the images have high definition, and the latency is as low as 70ms.

4 transmitters and 1 receiver share one wireless channel

This product supports 4 channel videos simultaneous input, with resolution up to 1080P60 per channel. 4 channel videos shares one wireless channel, which greatly saves spectrum resources and provides great convenience for users to perform multi-camera shooting.

Beam-Forming

Combined with 4x4 MIMO and Beam-Forming technology, this product has advantages over other WiFi products in the market in terms of transmission distance and image bitrate. Beam-Forming technology makes wireless signals more concentrated and stronger in the direction from which they are transmitted to the receiver, allowing them to transmit farther and be less susceptible to interference from other signals, thus making them more stable.

Standard mode and streaming mode

This product supports switching between two operating modes, namely standard mode and RTSP streaming mode. In standard mode, this product supports 4TX-to-1RX and 4TX-to-2RX, and the video outputs interface are HDMI and 3G-SDI. In RTSP streaming mode, this product supports 4TX-to-1RX and 4TX-to-2RX, and the video streaming interface is LAN port(RJ45) ..

Support RS232/422

This product supports controlling signal transmission via RS232/422 interface, which is convenient for users to control the transmitting terminal through the device at the receiving terminal, such as the PTZ.

Support monitoring on mobile devices

This product supports monitoring on portable devices, like mobile phone, tablet and PC. User can install live streaming tool supporting RTSP like VLC on mobile device, and connect portable devices with receiver via WiFi to watch the live video with different transmitter IP address.

Packing List

The following items are included in the product package

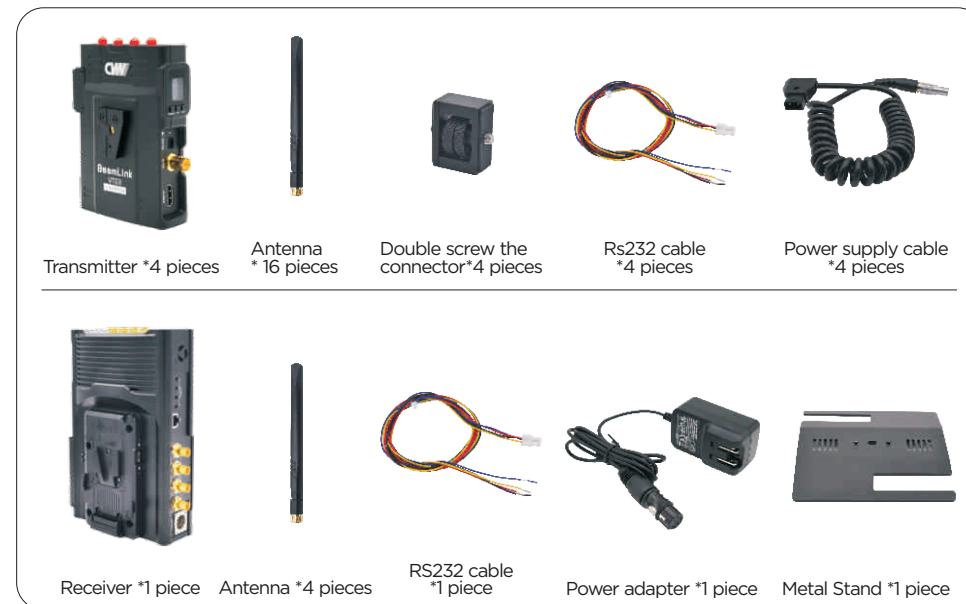

Notice: The transmitter comes with the Sony NP-F type battery dock and has preassembled V-mount connector. The receiver has preassembled V-mount battery plate and V-mount connector.

Structure & Interface

TX: 7060

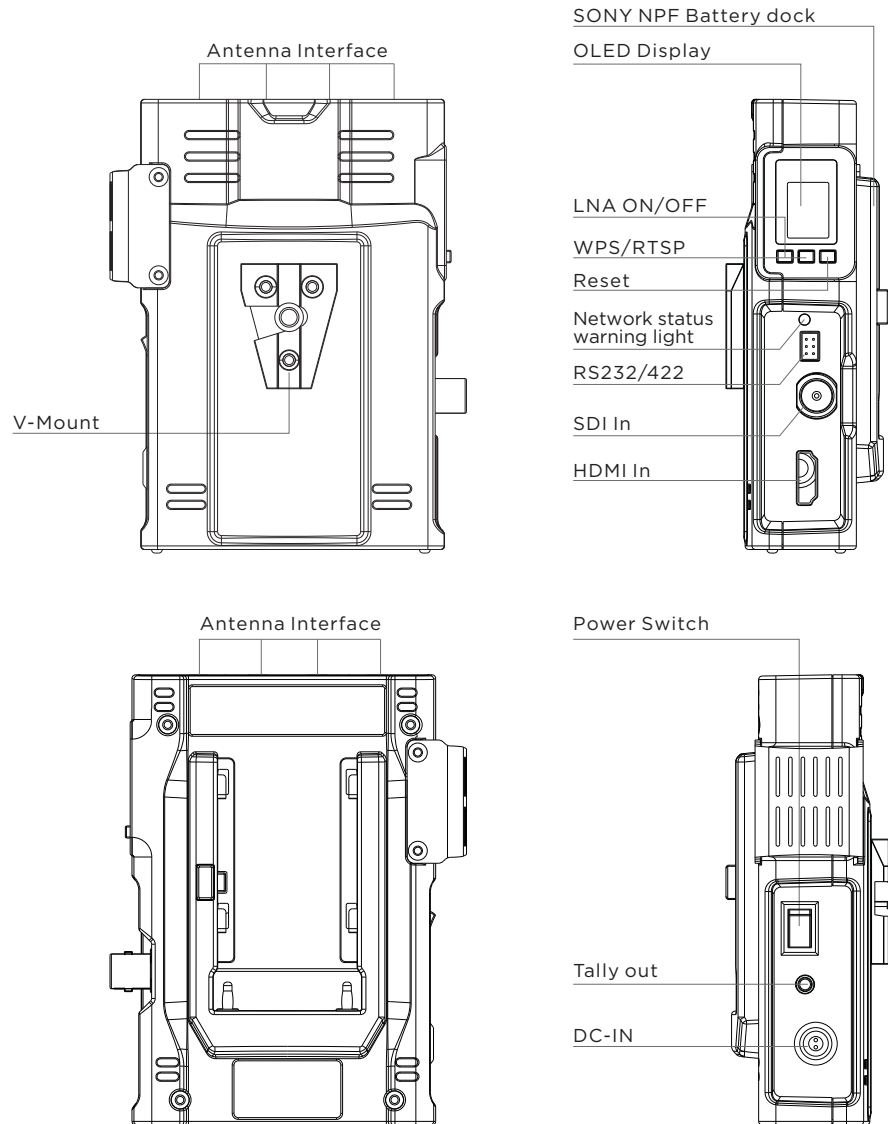

Transmitter Key Operation

Function	Operation	Description
High-gain and low-gain mode switching	Press the "LNA ON/OFF" button for about 3s	<p>"L" (low-gain) mode: Applicable for close-range (<200m/656ft & LOS) and strong interference environments, with strong anti-interference ability. After switching to L mode, the "L" character will be displayed on the OLED display.</p> <p>"H" (high-gain) mode: Applicable for long distances, (NLOS or >200m/656ft) and the anti-interference ability is weaker than that in "L" mode. After switching to H mode, the characters on the OLED display will disappear.</p>
Code matching	Press the "WPS/RTSP" button for about 3s	In the code matching process of the transmitter and receiver, the word "WPS" will always be displayed on the OLED display, and the string will disappear after the code matching. The transmitter and receiver need to be in code matching status at the same time to achieve code matching.
Standard and streaming mode switching	Press the "WPS/RTSP" button for about 6s	<p>When switching to streaming mode, the word "RTSP" will be displayed on the OLED display, and the product will enter streaming mode.</p> <p>Tips: in RTSP mode, the decoding function is disabled</p>
Restart the encoding board	Press the "RESET" button for about 3s	During the restart of the encoding board, the "RESET" string will always be displayed on the OLED display of the transmitter, and the string will disappear after the restart.

RX: 3060

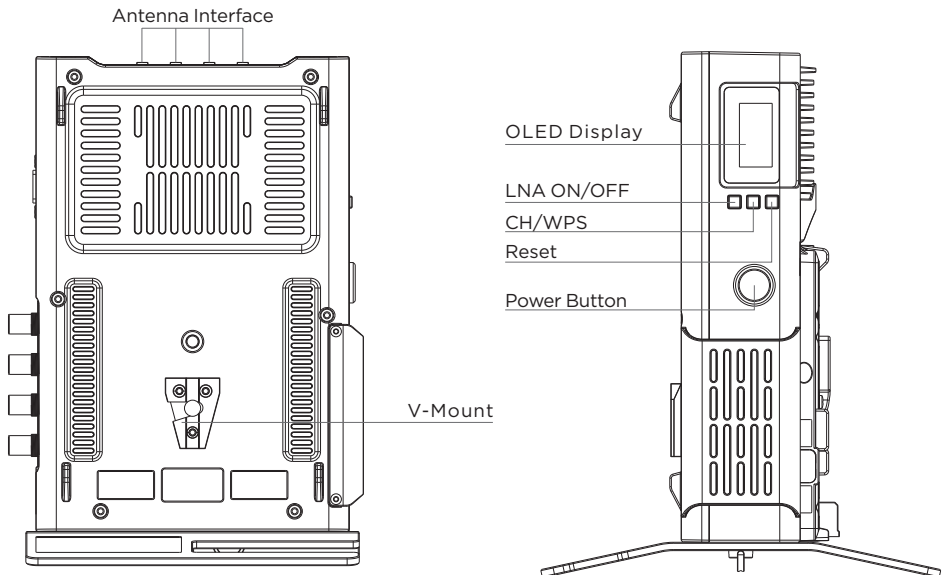
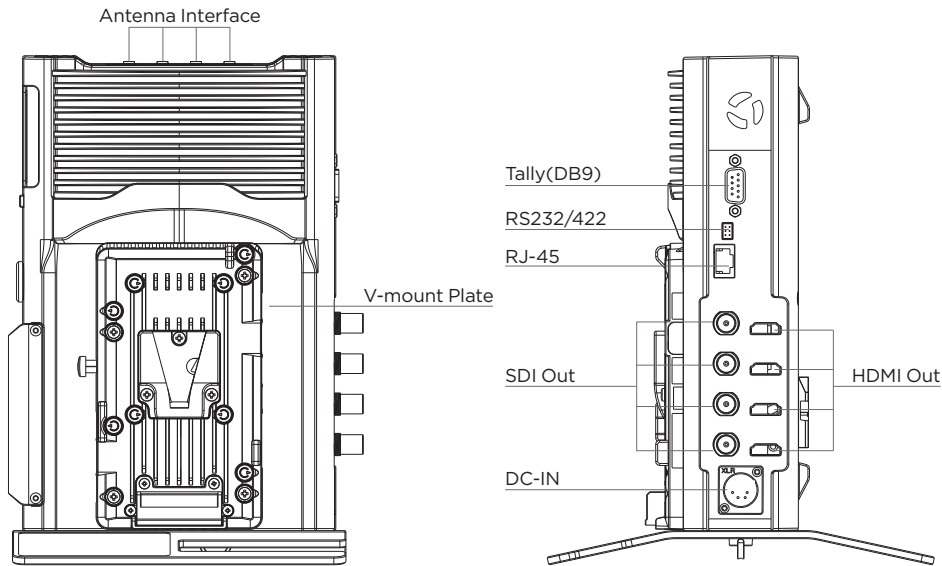

Receiver Key Operation

Function	Operation	Description
Frequency channel switching	Short press the "CH/WPS" button about 1S	After the receiver switches the frequency channel about 1S, the OLED display of the receiver and transmitter will display the new frequency channel about 1S number after switching.
High-gain and low-gain mode switching	Press the "LNA ON/OFF" button for about 3s	<p>"L" (low-gain) mode: Applicable for close-range (LOS &TX-to-RX <200m/656ft) and strong interference environments, with strong anti-interference ability. After switching to L mode, the "L" character will be displayed on the OLED display.</p> <p>"H" (high-gain) mode: Applicable for long distances,(NLOS or TX-to-RX>200m/656ft) and the anti-interference ability is weaker than that in "L" mode. After switching to H mode, the characters on the OLED display will disappear.</p>
Code matching	Press the "CH/WPS" button for about 3s	In the code matching process of the transmitter and receiver, the word "WPS" will always be displayed on the OLED display, and the string will disappear after the code matched. The transmitter and receiver need to be in code matching status at the same time to achieve code matching.
OLED display switching between landscape mode and portrait mode	Short press the "LNA ON/OFF" button for about 1s	Short press the "LNA ON/OFF" button, and the display will switch between landscape mode and portrait mode.
Restart a certain channel video of the receiver	First, short press the [RESET] button for cyclical selection among 1, 2, 3 and 4 to restart the decoding board in the channel. Then press and hold the [RESET] button for 3s to confirm the restart.	After long pressing the button to confirm, the "RESET" string will be displayed on the OLED display for 3s, and the string will disappear after the decoding board begins to restart.

Product Installation

For transmitter

1. Please install all the antennas on the transmitter and make them in a fan shape as shown in the picture.

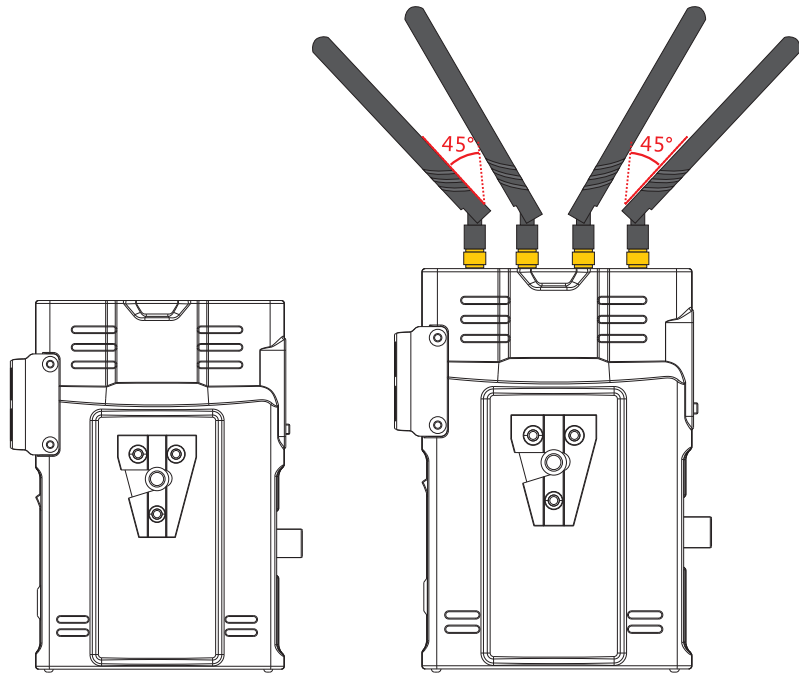

2. Please fix the transmitter via the screw at the bottom or the V-mount at the back, and place it at a height of around 1.5 to 2 meters above floor. Please make sure that the distance between each transmitter is more than 1 meter.

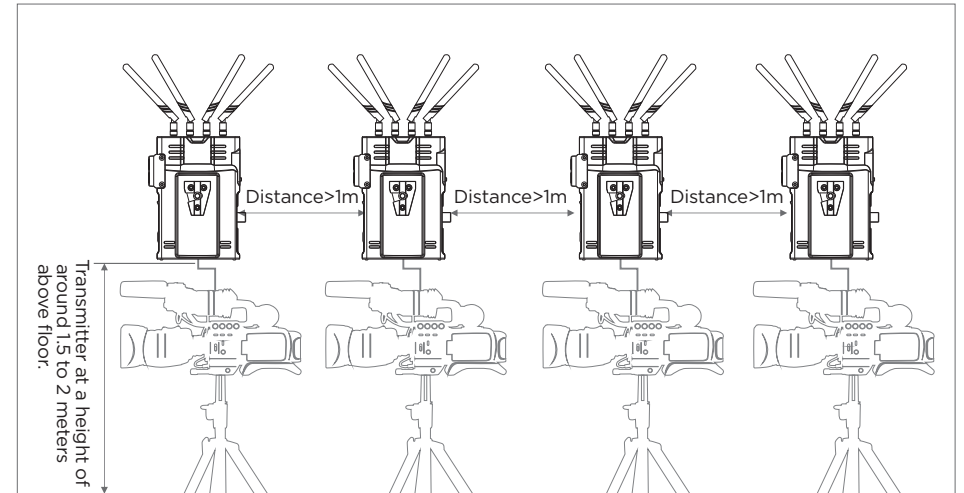

3. Please connect the transmitter and camera with SDI or HDMI cable.

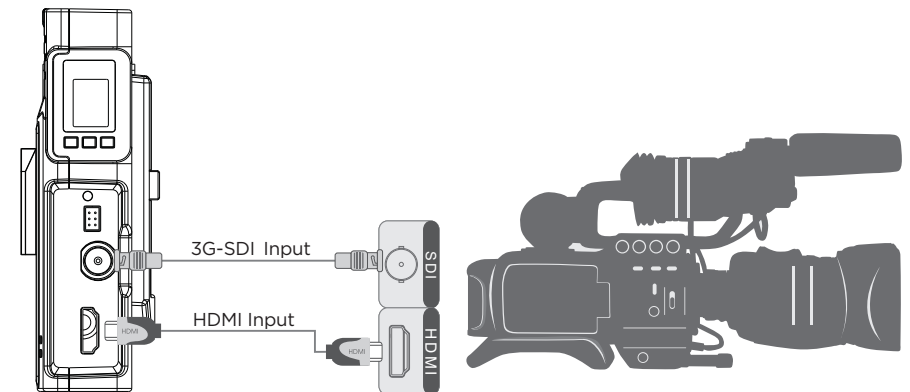

Receiver Installation

1. Please install all the antennas on the receiver, and make them in a fan shape as shown in the picture.

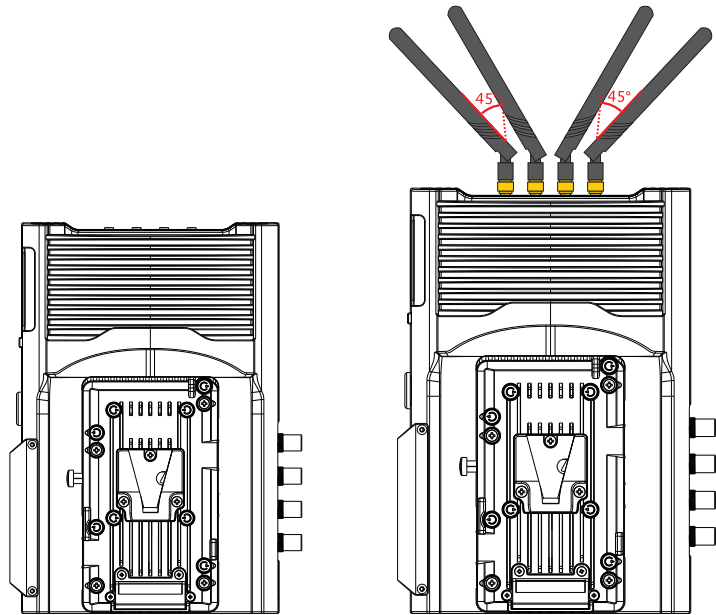

2. Please place the receiver at a height of around 1.5 to 2 meters above floor. Receiver can be placed in vertical or horizontal positions, and can be fixed via the screw at the bottom or V-mount at the back. Please install the affiliated metal stand before placing the receiver in vertical position.

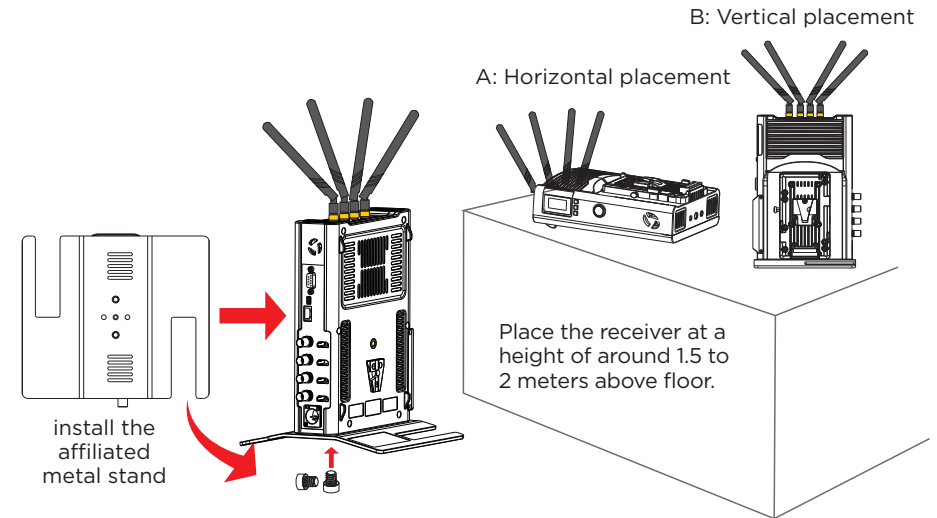

3. Please connect the receiver and video switch console or monitor with SDI or/and HDMI cable.

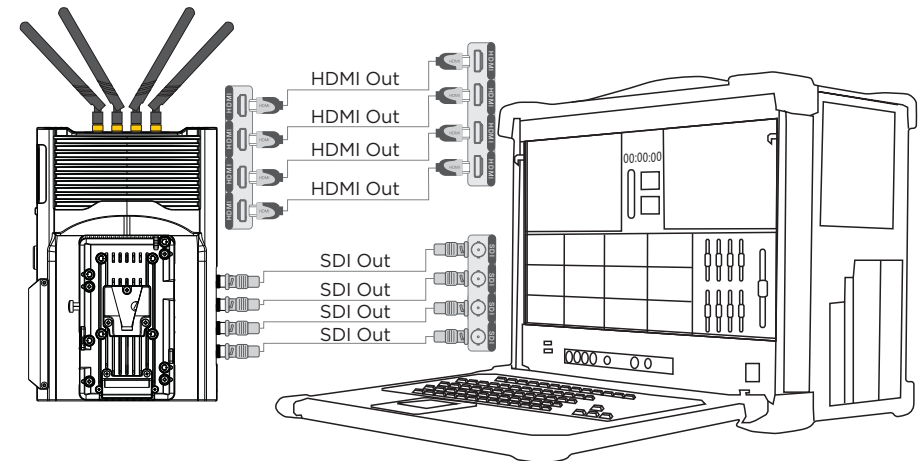

4. The receiver can be powered by both the V-mount battery and DC-IN port via the affiliated power adapter. If the mentioned two types of power supply are connected at the same time, the lithium battery is prioritized in power supplying, and the battery will switch to the power adapter for power supplying automatically after the battery power is exhausted.

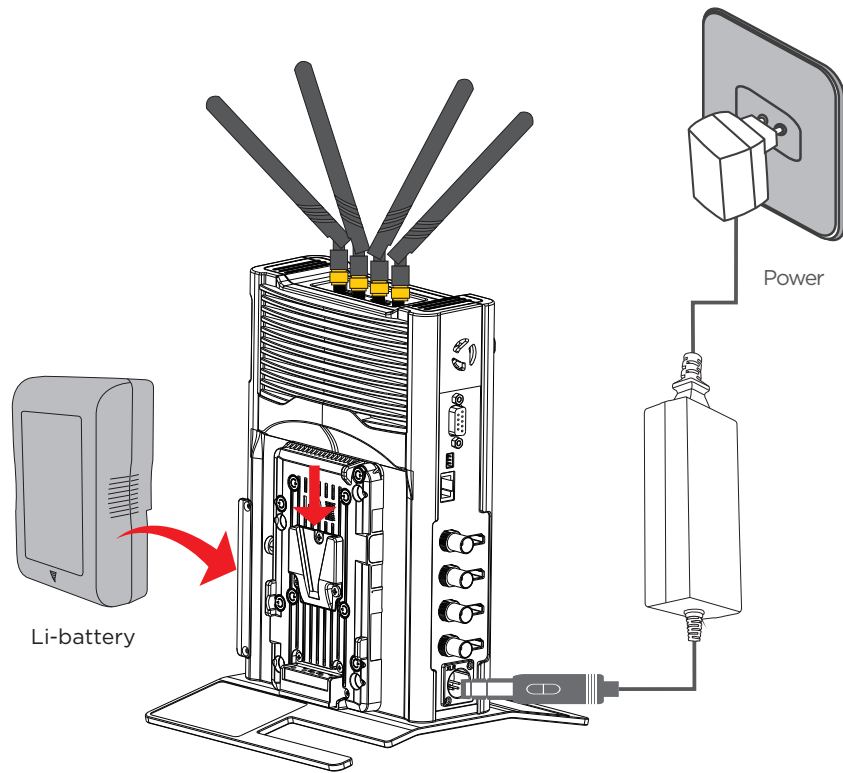

This system supports tally function. When the receiver is activated by low-level current, the transmitter will output high-level current signal.

Product Application

Standard mode

In standard mode, the four channel video sources are transmitted to the four transmitters via HDMI or SDI respectively. The receiver will receive the four channel signals and transport them to switch console or/and monitor via HDMI or/and SDI.

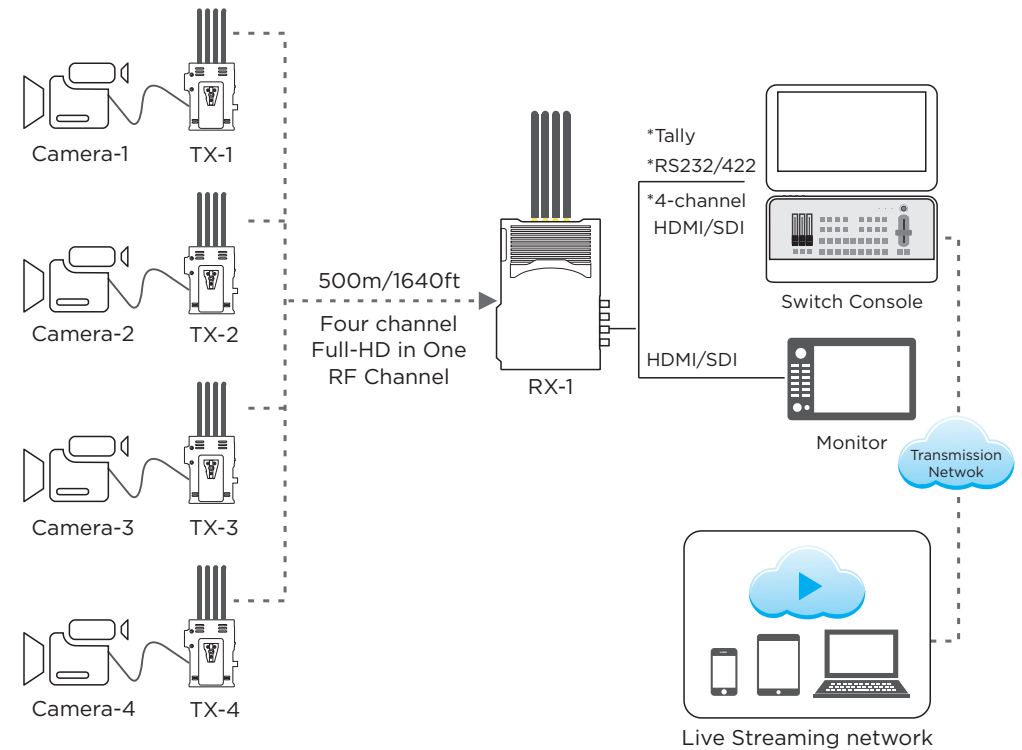

Streaming mode

In streaming mode, the four channel video sources are transmitted to the four transmitters via HDMI or SDI respectively. The receiver will receive the four RTSP streamings from the four transmitters and send them to the switch console through the LAN port. You can also connect the receiver with mobile devices such as your mobile phone, tablet and PC via WiFi, and watch the live video on the mobile phone, tablet and PC.

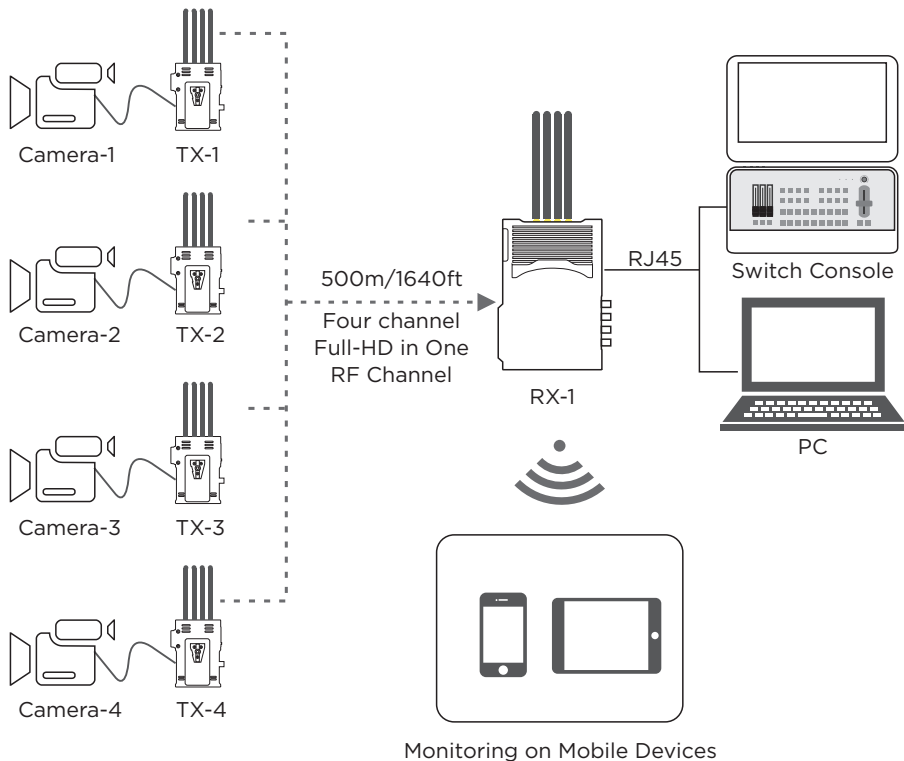

OLED Display Description

TX:7060

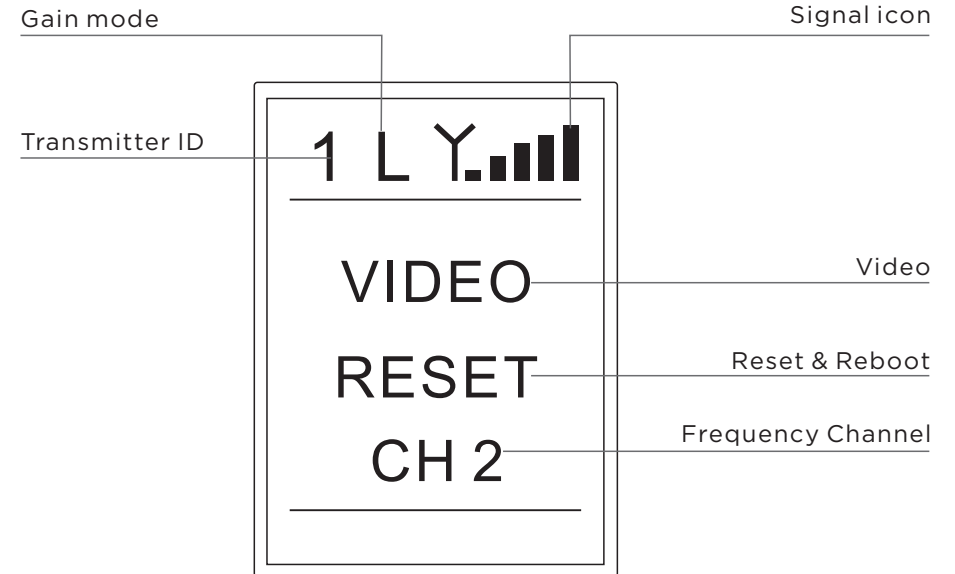

Icon	Content	Status
Transmitter ID	Numbers 1-4	Four transmitters are numbered 1, 2, 3 and 4, respectively
Gain Mode	L	Low-gain mode
	Blank	High-gain mode
Signal Icon	X	Connecting
	Signal bar	Successful network connection
Video	Blank	No video signal input
	VIDEO	Video signal input connected
	WPS	In code matching status
Reset & Reboot	Reset	The device is resetting and rebooting
Frequency Channel	CH*	Display current frequency channel (1-11)

RX:3060

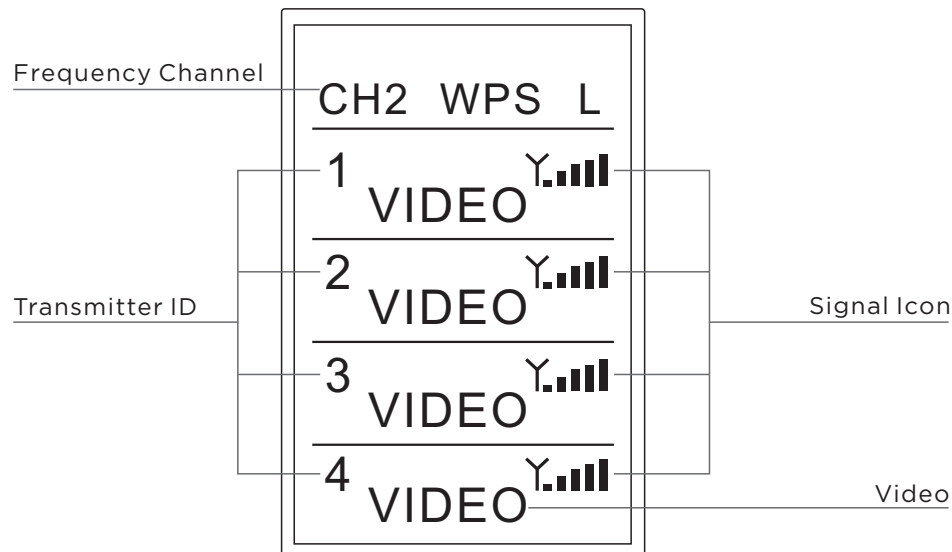

Icon	Content	Status
Transmitter ID	Numbers 1-4	Four transmitters are numbered 1, 2, 3 and 4, respectively
Frequency Channel	CH*	Display current frequency channel (1-11)
Signal Icon	X	Connecting
	Signal bar	Successful network connection
Video	Blank	No video signal received from TX
	VIDEO	Video signal received from TX
Gain State	L	Low gain mode
	Blank	High gain mode
WPS	Blank	Standard work mode
	WPS	WPS Pairing

Functional Instructions

Tally function

Insert the Tally light into the transmitter's Tally output interface first, then connect the switch console to the receiver's Tally input interface, and then control the Tally light of the four transmitters through the switch console. When the receiver is triggered by a low-level current, the transmitter's Tally light is on.

Tally interface of the transmitter and receiver: The transmitter's Tally interface is a standard $\phi 3.5$ headphone interface. The receiver's Tally interface is a DB9 female.

Tally light output interface:

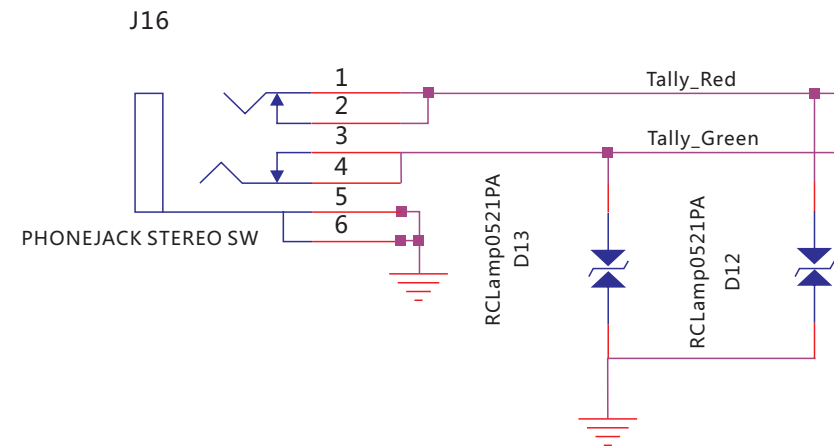

The DB9 header of the Tally input interface is defined as follows:

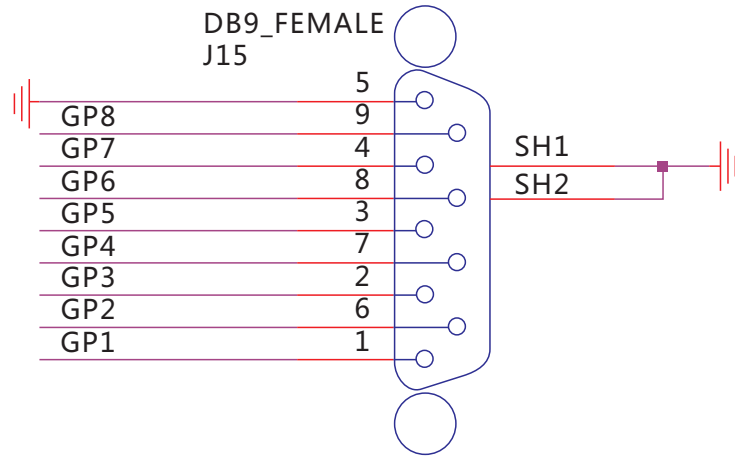

RS232/RS422 transparent transmission

Description:

This interface defaults to RS232 function. For RS422 function, contact the sales staff in advance for customized information!

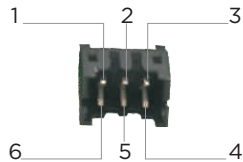

Pin No	RS232		RS422	
	Name	Description	Name	Description
1	NC	NC	RXD-	Receive data RX-
2	P12V	No voltage output by default (Reserve 12V voltage output)	P12V	No voltage output by default (Reserve 12V voltage output)
3	NC	NC	TXD-	Transmit data TX-
4	TXD	Transmit data TX	TXD+	Transmit data TX+
5	GND	Ground	GND	Ground
6	RXD	Receive data RX	RXD+	Receive data RX+

Attached: Baud rate settings

Log in to the backplane parameter settings page to change the baud rate settings: (For specific operating steps, refer to “Video Parameter Settings”)

Streaming Function

When using the functions in streaming mode, the transmitter needs to switch to streaming mode. At this time, the word “RTSP” is displayed on the transmitter’s OLED display, the SDI and HDMI at the receiver have no video output, and the image is transmitted to the streaming media software through the LAN port of the receiver for decoding display. The streaming mode depends on software decoding. Comply with lots of streaming media software. The following is an example of common VLC streaming media software: After the transmitter and receiver establish a network connection, the transmitter network indicator is always on, the receiver network connection is normal; the transmitter is connected to the HDMI or SDI video source, and the receiver’s network port is connected to the streaming device.

Take the VLC of the PC as an example. After running VLC, select to turn on the network stream. Fill in the address “rtsp://corresponding transmitter encoding board IP address/media/live/0”. Click “Play” to start streaming.

Note that the transmitter must be connected to the video source, and the IP address of the terminal streaming device (such as a computer) must be the same network segment as the IP address of the encoding board. Otherwise, the streaming will fail.

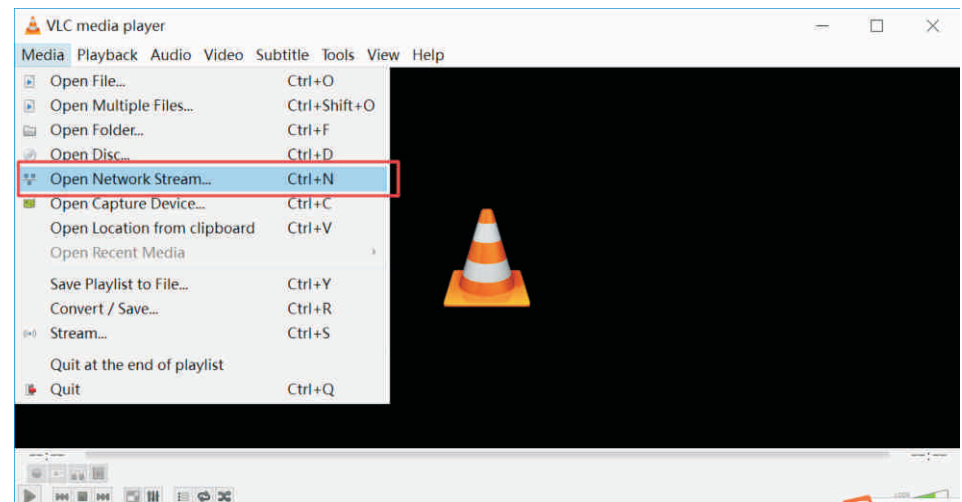

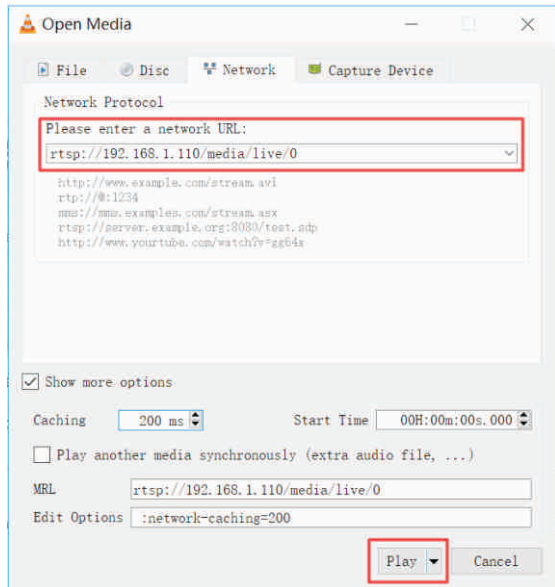

Encoder/Decoder Configuration and Upgrading

Each transmitter has one encoder, and its configuration and software upgrading need to be implemented on its encoder. Since the receiver has four decoders, the configuration and software upgrading need to be implemented on its each decoder respectively.

Keep the computer connected to the receiver through LAN port, and keep the receiver connected with all transmitters normally.

Each transmitter has one wireless transmission module and one encoder. Receiver has one wireless transmission module and four decoders. All modules and each encoder/decoder have their respective IP address as follows, and all configuration and upgrading operation must be implemented under its own IP address.

Transmitter	
Wireless transmission module IP (WiFi IP)	192.168.1.201, 192.168.1.202, 192.168.1.203, 192.168.1.204
Encoder IP	192.168.1.111, 192.168.1.112, 192.168.1.113, 192.168.1.114
Receiver	
Wireless transmission module IP (WiFi IP)	192.168.1.100
Decoder IP	192.168.1.211, 192.168.1.212, 192.168.1.213, 192.168.1.214

Open internet browser, and enter transmitter's encoder or receiver's decoder IP address in the address bar to enter the parameter settings page.

All transmitter's encoder and receiver's decoders need to be configured one by one, please refer to the following configuration case.

Transmitter Encoder Case (transmitter 2):

IP ETHADDR
192.168.1.112 → Transmitter IP address(192.168.1.111-114). Do not change the IP, otherwise the wireless connection will be shut down.

GROUP
2222 → Transmitter ID (four devices correspond to 1111, 2222, 3333 and 4444, respectively), Do not change the ID, otherwise the wireless connection will be shut down

Standard Mode Bitrate
8000 Range(1000-25000) → Transmission bitrate

RTSP Bitrate
Range(1000-15000) → RTSP streaming bitrate

SDI Audio Mode 0 1

Serial Baud Rate 2400 9600 19200 38400 57600 115200 → Serial baud rate

File Upload: 未选择任何文件 (Select A Local File)

Save the configuration and then reboot...

② Software upgrade: ① Select a file; ② Click Save

Receiver module: (Since the receiver has four decoders, there are four corresponding IP addresses need to be configured)

Receiver Decoder Case (Decoder 2):

Version:CM3060V3.15 → Software version

IP ETHADDR
192.168.1.212 → Decoder IP address (192.168.1.211-214)

GROUP
2222 → Corresponding transmitter ID (1111/2222/3333/4444)

LATENCY_MODE
1

Serial Baud Rate 2400 9600 19200 38400 57600 115200 → Serial baud rate

File Upload: 未选择任何文件 (Select A Local File)

Save the configuration and then reboot...

② Software upgrade:
① Select the file to be upgraded
② Click Save to complete the upgrade

Wireless Transmission Module Upgrading

Each transmitter has one wireless transmission module, and the software upgrading needs to be implemented on each transmitter. Receiver also has one wireless transmission module, and the software upgrading needs to be implemented on it accordingly.

1. The transmitter operates the same as the wireless software upgrade of the receiver.
2. The back of each device's body will be labeled with the IP address of WiFi and the IP address of the encoder/decoder. The default IP addresses are as follows:

Transmitter	
Wireless transmission module IP (WiFi IP)	192.168.1.201, 192.168.1.202, 192.168.1.203, 192.168.1.204
Encoder IP	192.168.1.111, 192.168.1.112, 192.168.1.113, 192.168.1.114
Receiver	
Wireless transmission module IP (WiFi IP)	192.168.1.100
Decoder IP	192.168.1.211, 192.168.1.212, 192.168.1.213, 192.168.1.214

(Take the following figure as an example: The device's operating mode, WiFi IP(wireless transmission module IP), and IP of the Encoder/Decoder can be found.)

Information label on transmitter:

Mode:STA
 WiFi IP:192.168.1.201
 Encoder IP:192.168.1.111

First, connect the computer to the LAN port of the receiver;

Then enter the device's WiFi IP (wireless transmission module IP) in the address bar to enter the login page:

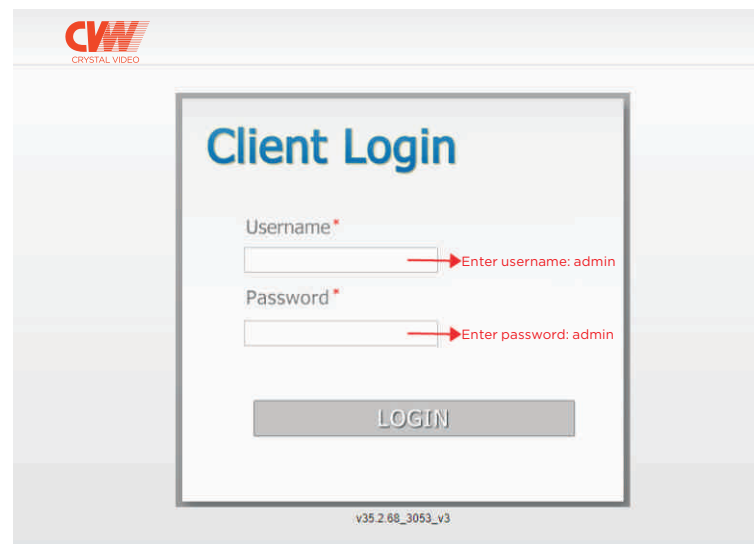

After successful login, enter the WiFi board parameter page of the device:

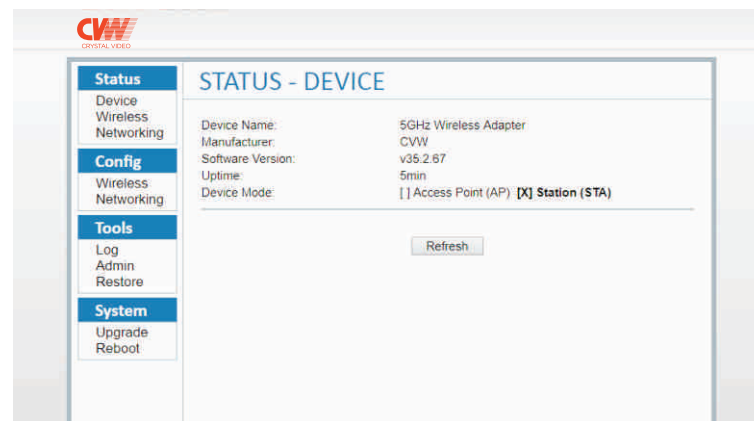

Select the “Upgrade” option in the “System” column.

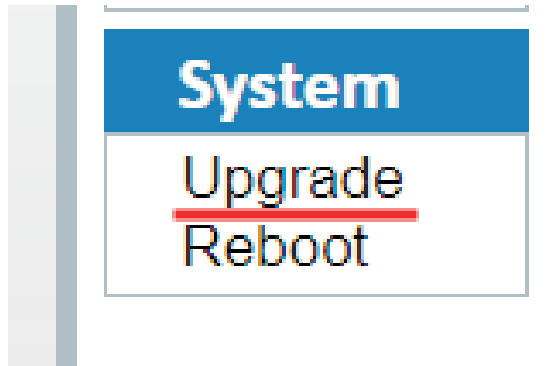

On the “Upgrade” settings page:

The software for the product WiFi board can be upgraded:

1. Select the software file to be upgraded
2. Click to upgrade

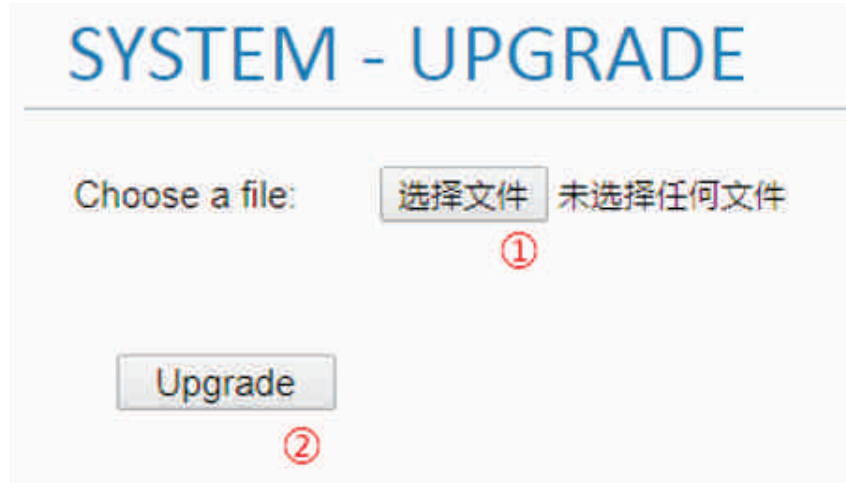

Product Specifications

ITEM	TX:7060	RX:3060
Frequency	5190MHZ, 5230MHZ, 5755MHZ, 5795MHZ Optional: 5270MHZ, 5310MHZ, 5510MHZ, 5550MHZ, 5590MHZ, 5630MHZ, 5670MHZ	
Antenna	4*4 MIMO 5dBi External antenna	
Modulation mode	OFDM	
Transmission Power	17dBm	
EVM	≤-28dB	
Receiving Sensitivity	≤-70dBm	
Bandwidth	40MHz	
Wireless	802.11n	
Network encryption	WPA2/WPS	
Network model	Point to point, RTSP	
Transmission Distance	500m(video code rate: 8Mbps per channel)	
Transmission Delay	70ms(min)	
code function	Support code	
HDMI Protocol	Support HDMI 1.4	
Video Resolution	1080p,1080i,720p (up to 1080P/60Hz)	
Audio Format	PCM	
Video Compression Format	H.264	
Remote control	RS232/RS422	
IO port signal return	Support Tally signal return	
Interface	SDI in * 1; HDMI in * 1; Tally output * 1; Lemo power coordinates *1; Antenna sub *4; Key * 3; Ship type power switch *1; OLED display screen *1; Np-F970 battery holder *1	SDI output *4; HDMI output *4; DB9(Tally in) * 1; Antenna sub *4; Power supply coordinate *1; Metal power switch *1; Display screen *1; Key * 3; Battery button connection seat *1
Power Consumption	10W	20W
Operating Power Supply	DC 12V/2A	DC 12V/3A
Temperature	-10°C - 50°C(Working); -40°C - 80°C(Storage)	
Operating voltage	7-17V	

Trouble Shooting

Trouble	Solutions
If mosaics or jams appear during use	<p>Lift the transmitter and receiver as high as possible, to 1.5-2m or more;</p> <p>The antennas are installed in fan-shape and facing forward to receiver, and the transmission effect is the best;</p> <p>The LNA mode is set in H (high-gain mode);</p> <p>When multiple transmitters function at the same time, ensure that the transmitters are at least 1m apart from each other;</p> <p>If there is still a mosaic or a jam, switch the product frequency to the intermediate frequency.</p>
If smear or frame loss appears during use:	<p>If the latency configuration has been changed, confirm the software version of the encoder and decoder and contact the technician in time. If the software version is confirmed to be too old, it is necessary to upgrade the software.</p>
If there is no connection during use, It is divided into 2 cases:	<p>In close range situation(TX-to-RX<2m), if the transmitter and receiver are connected to 4 antennas, the distance needs to be extended to 5m, and the LNA mode should be set to L (low-gain mode); when multiple transmitters function at the same time, ensure that the transmitters are at least 1m apart from each other;</p> <p>In the long-distance situation(TX-to-RX>2m), lift the transmitter and receiver as high as possible, to 1.5-2m or more; the antenna is fan-shaped and facing forward, and the transmission effect is the best; the LNA mode is set to H (high-gain mode); when multiple transmitters function at the same time, ensure that the transmitters are at least 1m apart from each other.</p>

Precautions

1. If transmitter or/and receiver use HDMI cable:(a~f)
 - a. Do not plug in or pull out the HDMI cable of the transmitter and receiver during normal use.
 - b. Connect the transmitter to the video source and connect receiver to a monitor via HDMI and then power on the transmitter and receiver.
 - c. When the OSD prompts that code matching fails after trying code matching, reboot the transmitter and receiver to see whether they can be connected normally. Perform code matching again when it is still unable to be connected after restarting.
 - d. When there is no video source output since a blank screen appears during the receiver output after switching the video source resolution, pull out and then plug in the HDMI cable of the transmitter or receiver. If the HDMI cable cannot be recovered after removal and insertion, power off and restart the transmitter and receiver.
 - e. When the network cannot be connected for a long time after switching frequency channel, reboot the transmitter and receiver.
 - f. When the transmitter and receiver devices are connected normally, there is no output on the monitor at the receiver, or the video output is abnormal, re-plug the HDMI cable of the receiver and check whether the monitor is on standby. If it is still unable to output normally after the above operation, try to replace the display device.
2. If there is a picture jam or mosaic during use, it is generally caused by interference in the network. Therefore, try switching the network frequency channel to avoid the interference band. The frequency channel switching operation refers to the frequency channel switching operation instructions.

3. When using the device, be sure to install the antenna before turning on the power. Failure to do so may result in damage to the device.
4. When used, the surrounding environment will affect the quality of wireless transmission. Poor operating environment may cause image sound disorder, such as picture pause, noise, etc. Therefore, pay attention to the following:
 - Walls, large metal plates, and appliances can affect wireless transmission. Try to avoid using in these environments.
 - In case of using in crowded conditions, the transmitter and receiver should be raised as high as 1.5-2m or more.
 - If a 5GHZ wireless device is used nearby, it may also cause interference to wireless transmission. Such issue can be solved by switching the frequency channel. It is recommended to switch the product frequency to the intermediate frequency in the case of interference.
 - Do not place the transmitter and receiver in a metal shelf, which will affect the wireless transmission. If it is unavoidable, consider leading the antenna out.
 - The transmitter and receiver are 1.5-2m above the ground. The antenna is fan-shaped and facing forward, and the transmission effect is the best.