

**FUJIFILM**  
Value from Innovation

CINE LENS



**FUJINON** CINE LENS

**ZK12×25** 25-300mm / T3.5-3.85

The versatile 4K high zoom ratio lens

# FUJINON CINE LENS

## ZK12×25 25-300mm / T3.5-3.85

### Offering advanced optical performance that supports 4K cameras

The lens features high-precision large-diameter aspheric elements, designed with Fujifilm's proprietary cutting-edge optical simulation technology. The use of the "three moving zoom group" system, which minimizes chromatic aberrations and controls image distortion across the entire zoom range while delivering edge-to-edge sharpness, enabling video production with a premium quality image.



### Broader range of scenes covered with a single lens for substantial improvement in on-site usability

Covering the most frequently-used range of focal lengths from 25mm to 300mm for the industry-leading 12x zoom ratio

### 9-blade round iris mechanism deliver natural bokeh in images

Using a 9-blade round iris mechanism to achieve the iris shape as round as possible, enabling natural bokeh in images

### Mechanical design in pursuit of comfort and operability

- The focus ring with a large 280-degree rotation angle to aid accurate focusing when precision is required; Smooth ring rotation to enable delicate operation.
- Featuring the Flange Back Focus\* Adjustment Mechanism and Macro Lever, used in television camera lenses to draw out the lens optical performance to the fullest

\*Distance from the lens mounting reference plane (flange) to the sensor



### Compatible with optional detachable drive unit

The lens can be combined with the optional drive unit to enable remote control of zooming, focusing and iris (aperture) adjustment. The availability of the Zoom Rate Demand and Focus Position Demand controls means the lens offers the operability equivalent to conventional television camera lenses, making it ideal for shooting movies, commercials, dramas or even providing live TV feed. Wired or wireless controls can be employed. With drive unit, lens meta data capable through electric contacts in the mount\*.

\*Cooke's /i technology and ARRI's LDS, lens communication feature is available.

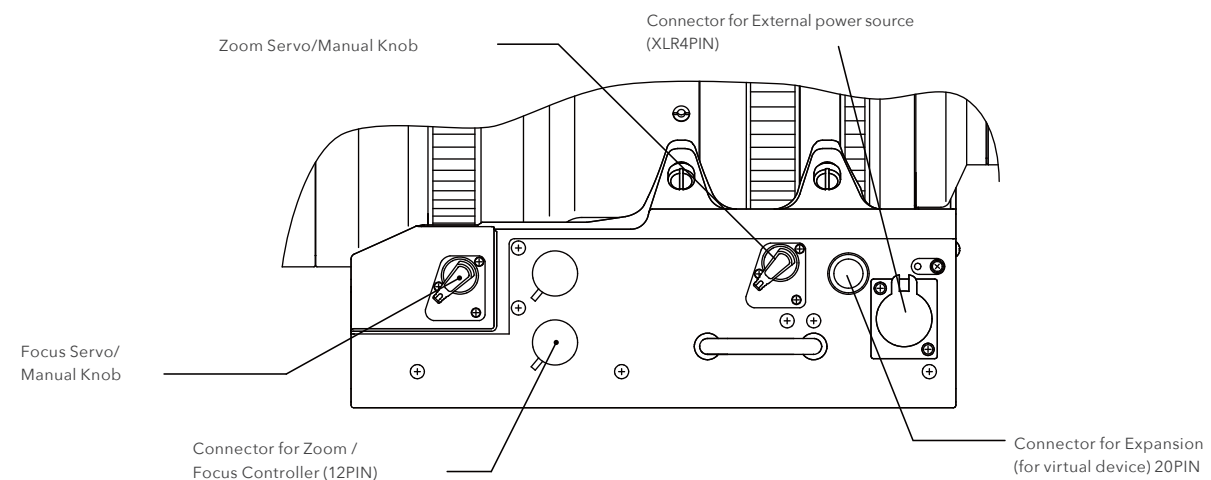

### Optional Accessories

#### Servo Control Kit

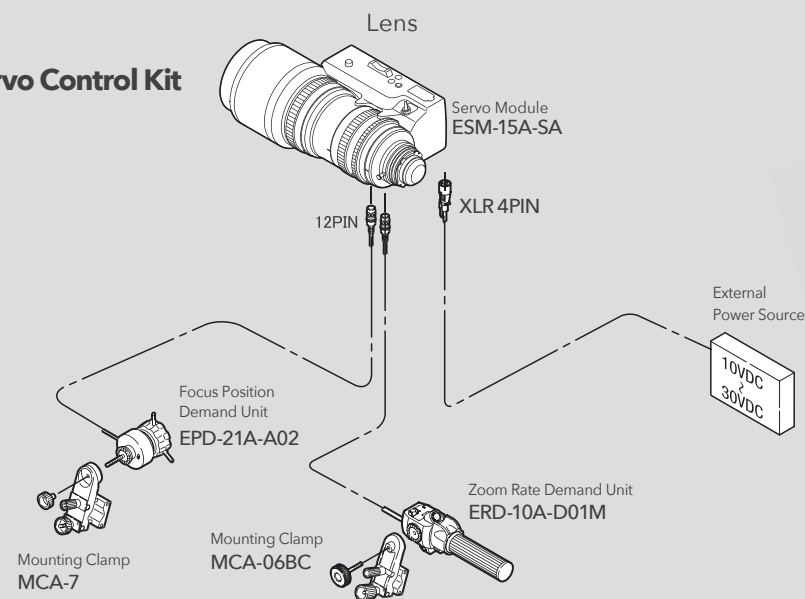

**DIGIPOWER**  
Zoom Rate Demand Unit  
ERD-10A-D01M  
+  
Mounting Clamp  
MCA-06BC



Focus Position Demand Unit  
EPD-21A-A02  
+  
Mounting Clamp  
MCA-7

FUJINON CINE LENS

# ZK12×25 25-300mm / T3.5-3.85



## Specification

Model Name	ZK12x25		
Application	35mm PL Mount Camera	Angular Field of View	25mm 57°32' × 34°19'
Focal Length	25-300mm	1.78 : 1 Aspect Ratio*	300mm 5°14' × 2°57'
Zoom Ratio	12 ×	Focus Rotation	280°
T-No.	T3.5(25-273mm) T3.85(300mm)	Zoom Rotation	120°
Iris Blades	9	Approx. Size ( Φ×Length)	Φ136 × 401mm
M.O.D.from Image Planes	1.2m / 4'	Approx. Mass	8.4kg(without Drive Unit)
Object Dimensions at M.O.D.	25mm 937 × 527mm		ZK12x25 servo drive unit is optionally available
1.78 : 1 Aspect Ratio*	300mm 77 × 43mm		

**FUJIFILM**  
FUJIFILM Corporation

1-324 Uetake, Kita-ku, Saitama City, Saitama, 331-9624, Japan  
[http://www.fujifilm.com/products/optical\\_devices/tv\\_cine/](http://www.fujifilm.com/products/optical_devices/tv_cine/)

Due to a continuous process of product improvement, design and specification are subject to change without notice.



### For Your Safety

Be certain to read the instruction for use before using any equipment.