

Panasonic

AJ-D455

DVCPRO Studio Editing VTR
(PAL:625)



DVCPRO



The Core of Your New-Generation D



Panasonic introduces a new-generation DVCPRO studio VTR that meets today's most advanced requirements in professional image production.

The AJ-D455 comes

equipped with AES/EBU digital audio in/out and offers optional boards for SDI and IEEE1394 digital interfacing. This compact unit accommodates a range of digital video systems and provides both playback and recording in the DVCPRO and DV formats. From full-scale digital video editing to new applications like webcasting, the versatile AJ-D455 represents a cost-effective solution to a wide range of professional needs.

Ultra-Reliable DVCPRO Format

Developed for broadcast use, the DVCPRO format was designed for high reliability. It uses a metal particle (MP) tape with proven performance in professional applications. And its original track pattern, featuring an 18-micron track pitch — almost twice that of DV formats — as well as control track (CTL) and analogue CUE tracks, ensures optimal accuracy for video editing.

Outstanding Picture and Sound Quality

The AJ-D455's digital component recording assures superb pictures, with a video Y bandwidth of 5.5 MHz and video S/N ratio of 55 dB. For audio that surpasses CD quality, it features two 16-bit digital audio channels with 48-kHz sampling. There's also one analogue cue track. Using the optional digital interface, both picture and audio quality remain high even after editing and repeated dubbing.

184 Minutes Recording/Playback

The AJ-D455 can use the AJ-5P92LP DVCPRO tape to provide up to 184 minutes of continuous recording and playback, permitting the recording of extended programming onto a single tape cassette for added convenience in production and transmission. For field recording, 66-minute M cassettes can also be utilized without the need for an adaptor.

DV Format Recording and Playback

The AJ-D455 is the first DVCPRO VTR to offer DV-format recording. Recording and playback are possible with both standard and Mini-DV cassettes for cost-effective, extended-time applications. The new AJ-CS455 Mini-DV cassette adaptor is provided as a standard accessory. The AJ-D455 also plays back DV camcorder tapes. In both recording and playback, a cassette detection function automatically selects the proper mode for the type of cassette loaded.

*The AJ-D455 cannot playback DV cassette tapes recorded in LP mode, or extended-time Mini-DV cassette tapes (80 minutes in SP mode, 120 minutes in LP mode), even with the cassette adaptor.

Full Digital Interfaces

- Digital Audio: Equipped with AES/EBU digital audio in/out (BNC connector)
- SDI In/Out: Serial digital interface (video/audio, ITU-R BT.656-3) in/out capability with the optional AJ-YA455P board
- IEEE1394: Input/output of IEEE1394 (FireWire) possible* with the optional AJ-YAD455P board. Ideal for back-up recording with a DV camcorder or for uploading/downloading of digital video with a Windows or Macintosh PC.

*DVCPRO/DV conversion function through IEEE1394 interface is not allowed.

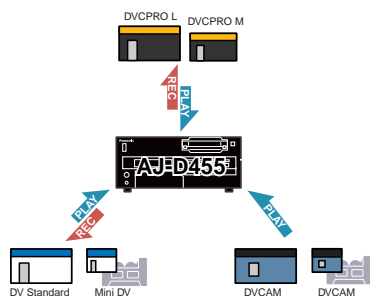

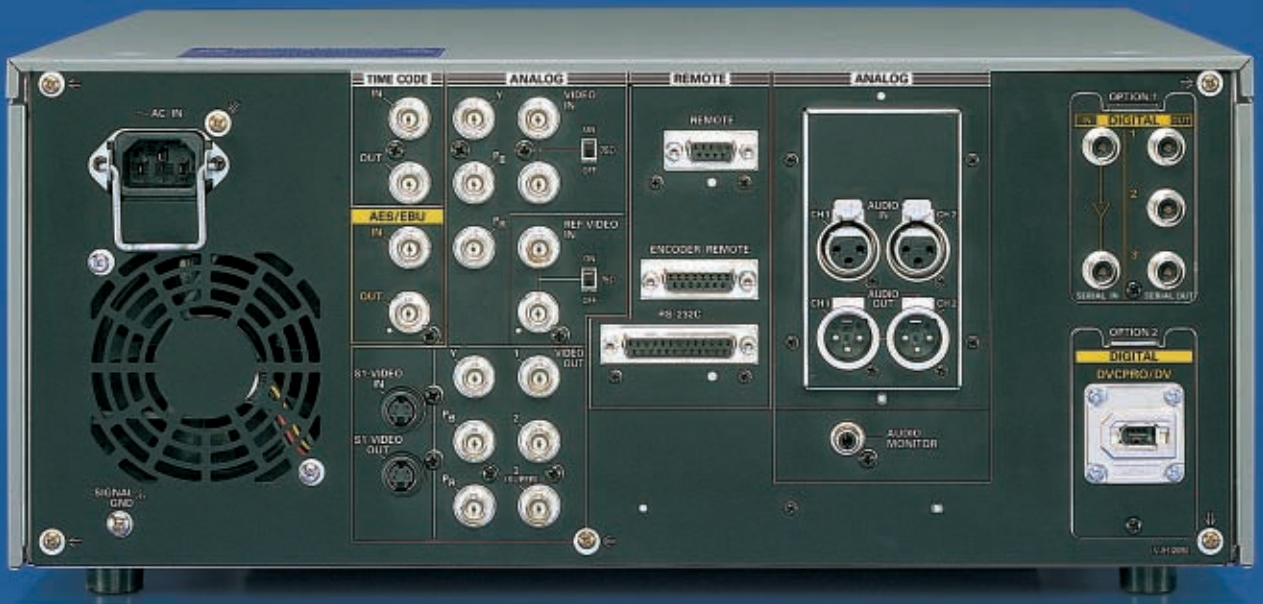

Digital Video Studio

Digital In/Out Signal Adjustment

Users can adjust audio recording levels for both analogue and digital inputs (AES/EBU, SDI). For convenience, a user can adjust each channel while watching the level meter display. Adjusting the output images from the AU-ER65B encoder remote controller is done the same way for digital output (SDI) as for analogue signals. The AJ-D455 greatly improves ease of use with digital interfaces.

Teams with High-Precision Editing Systems

The AJ-D455 features a built-in SMPTE/EBU time code generator and reader, and a 9-pin serial remote (RS-422A) terminal, which permits the VTR to be used with an external editing controller for high-precision (± 0 frame) editing.* Also, the DVCPRO control track contains colour frame information for perfectly colour-framed edits.

*Editing cannot be done in the DV record mode, also editing between two AJ-D455s through IEEE1394 cannot be assured.

Digital Slow Motion

The AJ-D455 offers Digital Still and Digital Slow Motion playback at up to $\pm 0.43x$ normal speed, with an external controller having slow motion capability (without interpolation).

High-Speed 60x, Full-Colour Search

When an external controller is used, the AJ-D455 provides forward or reverse searching at 16/32/60x normal speed (selected by a menu setting), with the search image in full colour, as well as jog operation. Generally, digital PCM audio cannot be heard at high search speeds. But DVCPRO has one analogue CUE track, and it allows users to set editing points listening to the recorded audio at high search speed. DVCPRO control track allows for intelligent tape handling.

Outstanding System Versatility

- Analogue In/Out: Component/composite/S-VIDEO video and analogue audio, allowing direct connection to existing analogue systems
- Data communication with computers is possible through the RS-232C terminal.
- With its compact 4U size, the AJ-D455 fits a 19-inch rack using the AJ-MA75P* Rack Mount Adaptor.

*slide rails are not included with AJ-MA75P

- Channel condition indicator lets the operator view actual conditions
- The On-Screen Menu Display permits a user to easily change many initial settings .

Digital Dubbing via IEEE1394

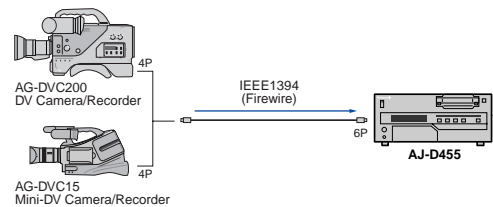

Upload/Download via IEEE1394

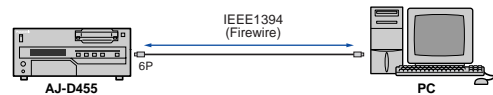

Editing System from DVCPRO/DV Source

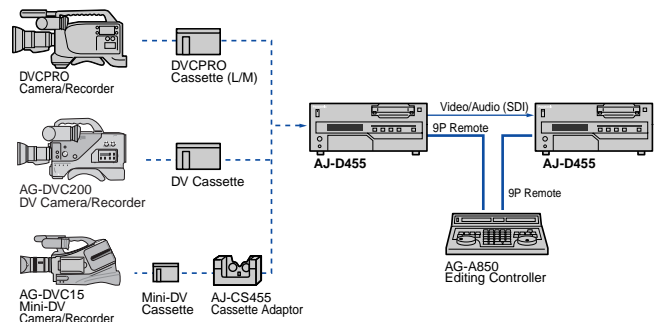

A/B Roll Editing System

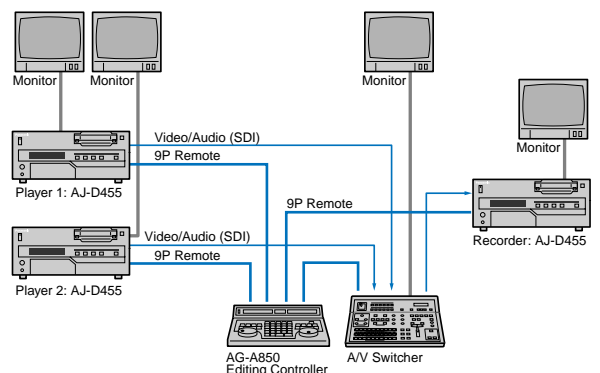

OPTIONAL ACCESSORIES



AJ-YAD455P
IEEE1394 Interface Board



AJ-YA455P
Component Digital Serial Interface Board

AU-ER65B
Encoder Remote Controller

AJ-CS455P
Mini-DV Cassette Adaptor

AJ-MA75P
Rack Mount Adaptor
(slide rail, not included)

AG-A850
Editing Controller



DVCPRO L-size Cassettes

Model No.	R/P Time	Length
AJ-5P92LP	184 min.	377 m
AJ-P126LP	126 min.	259 m
AJ-P94LP	94 min.	194 m
AJ-P66LP	66 min.	137 m
AJ-P34LP	34 min.	72 m

Cleaning Tape
AJ-CL12LP

DVCPRO M-size Cassettes

Model No.	R/P Time	Length
AJ-P66MP	66 min.	137 m
AJ-P46MP	46 min.	96 m
AJ-P33MP	33 min.	70 m
AJ-P24MP	24 min.	51 m
AJ-P12MP	12 min.	27 m

Cleaning Tape
AJ-CL12MP



DV Cassettes
(Master Series)

Model No.	R/P Time
AY-DV96MQ	96 min.
AY-DV124MQ	124 min.
AY-DV186MQ	186 min.
AY-DV276MQ	276 min.

Cleaning Tape
AY-DVCLB

DV Cassettes
(Professional Series)

Model No.	R/P Time
AY-DV96PQ	96 min.
AY-DV124PQ	124 min.
AY-DV186PQ	186 min.

SPECIFICATIONS

[General]

Power Requirement:	AC220V to 240 V ±10%, 50 to 60 Hz
Power Consumption:	95W
Operating Temperature:	5 °C to 40 °C
Operating Humidity:	10% to 90%
Weight:	14.3 kg
Dimensions (WxHxD):	424 x 175.2 x 415mm
Recording Format:	DVCPRO/DV
Recording Video Signal:	625i
Recording Audio Signal:	48 KHz 16 bits 2CH (DVCPRO)
Recording Track:	Digital Video, Digital Audio: Helical Track TC; Sub code area Digital Audio: 2CH Cue: 1 track CTL: 1 Track
Tape Speed:	33.854 mm/sec.
Recording/Playback Time:	Max. 184 min. (DVCPRO/AJ-5P92LP) Max. 276 min. (DV/AY-DV276MQ)
Tape:	DVCPRO: Metal Particle, DV: Metal Evaporated
FF/REW Time:	Less than 3 min. (with AJ-P126LP)
Editing Accuracy:	±0 frame (TC)
Tape Timer Accuracy:	±1 frame (CTL)
Search Speed:	±60x (in colour)
Digital Slow Motion:	-0.43 to +0.43
Servo Lock Time:	Less than 0.5 sec. (colour framing/standby ON)

[Video]

Sampling Frequency:	Y: 13.5MHz, PB/PR: 3.375MHz
Quantization:	8 bits
Compression Method:	DV-Based Compression (SMPTE314M)
Compression Ratio:	1/5
Error Correction:	Reed Solomon Product Code
Bit Rate:	25Mbps
sample x Active Line:	720x576/frame
Bandwidth (Analogue Out):	Y: 25Hz to 5.5MHz (+1 to -1.5dB) PB/PR: 25Hz to 1.3MHz (+1 to -2dB)
S/N (Analogue Out):	55 dB typ
K Factor (Analogue Out):	2% or less

[Processor adjustment range (Video Out)]

Video Gain:	±3 dB
Chroma Gain:	±3 dB
Chroma Phase:	±30°
Black Level:	±100 mV
Sync phase:	±15 μ sec.
SC phase:	±180°

[Audio]

Sampling Frequency:	48 kHz (sync. With video)
Quantization:	16 bits
Frequency Response:	20 Hz to 20 kHz ± 1.0 dB (reference level)
Dynamic Range:	More than 85 dB (1 kHz, emphasis off, "A" weighted)
Distortion:	within 0.1% (1 kHz, emphasis off, reference level)
Cross Talk:	Less than -80 dB (1 kHz, between 2channels)
Wow & Flutter:	Below measurable limit
Headroom:	18 dB
Emphasis:	T1=50μsec, T2=15μsec (ON/OFF Auto)

[Video Input]

Analogue Component:	BNC x 3 (Y,PB,PR) Y: 1.0Vp-p, 75 Ω PB/PR: 0.7Vp-p, 75 Ω (100% colour bar)
Analogue Composite:	BNC x 2, loop-through, 75 Ω On/Off
Analogue Y/C:	S-VIDEO (4P) x 1
Reference:	BNC x 2, loop-through, 75 Ω On/Off
SDI :	BNC x 2 (option), Active-through, ITU-R BT.656-3

[Video Output]

Analogue Component:	BNC x 3 (Y,PB,PR) Y: 1.0Vp-p 75 Ω PB/PR: 0.7 Vp-p, 75 Ω (100% colour bar)
Analogue Composite:	BNC x 3 Video1/Video2/Video3 (Super On/Off)
Analogue Y/C:	S-VIDEO (4P) x 1
SDI:	BNC x 3 (option), ITU-R BT.656-3

[Audio Input]

Analogue:	XLR x 2, 600 Ω/high-impedance switchable, +4/0/-20/-60 dBu
Digital:	BNC x 1, AES/EBU
SDI:	BNC, 75 Ω (option), ITU-R BT.656-3

[Audio Output]

Analogue:	XLR x 2, low-impedance, +4/0/-20dBu
Digital:	BNC x 1 AES/EBU
SDI:	BNC, 75 Ω (option) ITU-R BT.656-3
Monitor:	RCA x 1, 600 Ω, -8dBv
Headphone:	M6, variable level control, 8Ω

[Others]

Time Code Input:	BNC x 1, 0.5 to 8Vp-p, 10kΩ
Time Code Output:	BNC x 1, 2.0 ±0.5Vp-p, low-impedance
RS-422A Input:	D-sub 9pin RS-422A
RS-232C:	D-sub 25pin RS-232C
Encoder Remote In:	D-sub 15pin
IEEE1394:	6pin x 1, IEEE1394-1995 (option)

Weight and dimensions shown are approximate.
Features and specifications are subject to change without notice.
These products may be subject to export regulations.

Macintosh, Firewire and Windows are copyright of their respective owners.

Panasonic

Matsushita Electric Industrial Co., Ltd.
Systems Business Group
2-15 Matsuba-cho, Kadoma, Osaka 571-8503
Japan
Tel. 81-6-6905-4650 Fax. 81-6-6908-5969
www.panasonic.co.jp/bsd

[Countries and Regions]

Argentina	Tel. 54-1-308-1610	Iran	Tel. 98-21-2271463
Australia	Tel. 61-2-9887-6222	Italy	Tel. 39-02-67881
Austria	Tel. 43-1-61080-773	Jordan	Tel. 961-6-586-1914
Bahrain	Tel. 973-252292	Kuwait	Tel. 965-481-2123
Belgium	Tel. 32-2-481-0481	Lebanon	Tel. 961-1-216827
China	Tel. 86-10-6515-8828	Malaysia	Tel. 60-3-5549-5422
(Hong Kong)	Tel. 852-2313-0888	Netherlands	Tel. 31-73-640-2721
Czech Republic	Tel. 42-02-2166-4120	New Zealand	Tel. 64-9-272-0100
Denmark	Tel. 45-43-200-853	Norway	Tel. 47-22916800
Egypt	Tel. 20-2-3938151	Pakistan	Tel. 92-21-455-5766
Finland	Tel. 358-9-521-5253	Peru	Tel. 51-145-29470
France	Tel. 33-149464388	Poland	Tel. 48-3912-3173
Germany	Tel. 49-611-18160	Portugal	Tel. 351-21-424-8630
Greece	Tel. 30-1-969-2300	Russia	Tel. 7-095-258-4237
Hungary	Tel. 36-1-382-6060	Saudi Arabia	Tel. 966-1-465-0709
Indonesia	Tel. 62-21-801-5666 62-21-385-9449	Singapore	Tel. 65-6270-0110
		Slovakia	Tel. 421-7-5292-1423

South Africa	Tel. 27-11-313-1400
Spain	Tel. 34-93-425-9300
Sweden	Tel. 46-8-680-8238
Switzerland	Tel. 41-41-259-9632
Thailand	Tel. 66-2-731-8888
Turkey	Tel. 90-216-416-0150
U.A.E.	Tel. 971-4-282201
U.K	Tel. 44-118-902-9210

