

# Panasonic

# AJ-HD130 DC

1080i/720p DVCPRO HD Recorder

# HD HIGH DEFINITION



# DVCPRO HD

## The Smallest AC/DC-Powered HD Recorder for



Small, lightweight and easy to carry, the AC/DC-powered AJ-HD130DC joins the DVCPRO HD series of recorders with superior HD (1080i/720p) pictures and 8-channel audio. The AJ-HD130DC is around the same size as a waveform monitor and weighs less than 20 lbs. Accommodating both AC and DC power sources, it can be used on a desktop, in the field, in an OB van, or just about anywhere. The built-in HD/SD down converter allows image checks with existing SD monitors and simultaneous HD/SD data transmission. Versatile, mobile and easy to operate, the AJ-HD130DC brings new possibilities to HD program production, editing and playout.



### Small Size, Easy to Carry

Only 8-7/16" wide, 5-1/4" high, and 16-15/16" deep, the AJ-HD130DC is virtually the same size as a 3U-high waveform monitor. A space-saver in OB vans and other tight places, it is the smallest HD digital VTR for broadcast use. The AJ-HD130DC's light weight — less than 20 lbs. — and handle make it easy to carry from studio to field and back.



### AC/DC Operation

Operating on either AC or DC (12V), the versatile AJ-HD130DC is a great desktop or rack mount VTR that you can also take away for OB van or field use.

### 1/4" DVCPRO HD Format

The DVCPRO HD format brings DVCPRO's many advantages to HD production environments. Thanks to the small 1/4" tape and ultracompact mechanism, DVCPRO HD equipment is compact and lightweight, and running costs are low. A high-density 100-Mbps video recording system and high-efficiency compression algorithm achieve an outstanding level of picture quality.

### 46 Minutes of High-Quality HD Recording

A video recording rate of 100 Mbps and high-efficiency compression combine to deliver superior HD (1080i/720p) images. A compact DVCPRO HD cassette provides up to 46 minutes of high-quality, high reliability recording. The AJ-HD130DC handles both 1080i and 720p scanning lines.

### Built-In HD/SD Down Converter

The AJ-HD130DC lets you down-convert images from HD-SDI input and tape playback (1080i/59.94 and 720p/59.94) to SD (480i/59.94) images, and then output the SD images from SDI and/or composite video ports. This makes it possible to check recorded and incoming images on an existing NTSC monitor. HD and SD signals can also be output for simultaneous transmission of HD and SD signals. You can also change the aspect ratio, selecting from letterbox, squeeze, side cut, 14:9 cut, and 13:9 conversion modes.

\*The AJ-HD130DC cannot play back SD tapes, such as from DVCPRO P, DVCPRO50, DVCPRO, DV, and DVCAM sources.

### Equipped with HD SDI

The AJ-HD130DC is equipped with an HD Serial Digital Interface (1.5 Gbps, SMPTE292M/296M), for easy, reliable use with other digital HD equipment.

### 8-Channel Digital Audio

The AJ-HD130DC's eight channels of 16-bit/48kHz digital audio allow for multilingual, 5.1 surround sound, and conventional stereo applications. In operation, only channels 1-4 are available for playback and record via their analog ports. All eight channels are embedded within the HD-SDI data stream and will transfer accordingly to the AJ-HD150 for record and playback.

### Auto-Playback Functions

These automatic functions are convenient for presentations using HD images.

- **Auto Rewind:** Detects the tape end and automatically rewinds the tape.
- **Auto Repeat:** Repeatedly plays the section between two designated points.
- **Memory Stop:** Automatically stops the tape near a designated point during fast forward or rewind.

### Other Advanced Functions

- 4-channel analog audio in/out (Channel 3 and 4 can be switched for L/R monitor output use)
- Built-in SMPTE time code generator/reader and time code in/out
- Auto back function for seamless recording
- Rec inhibit on/off switch
- TAPE/EE output select switch
- Headphone output with volume control

### External Remote Controller: AJ-A95 (optional)

An RS-422A 9-pin remote control terminal lets you connect the optional AJ-A95 for remote control operation. In addition to basic operations like Rec, Play, and Pause, this option enables remote control shuttle searches at up to 16x normal speed. Jog and slow motion capabilities are also extended to the AJ-HD130DC. Connection to the AJ-A95 is simplified via a dedicated power port, eliminating the need for an AC adapter.

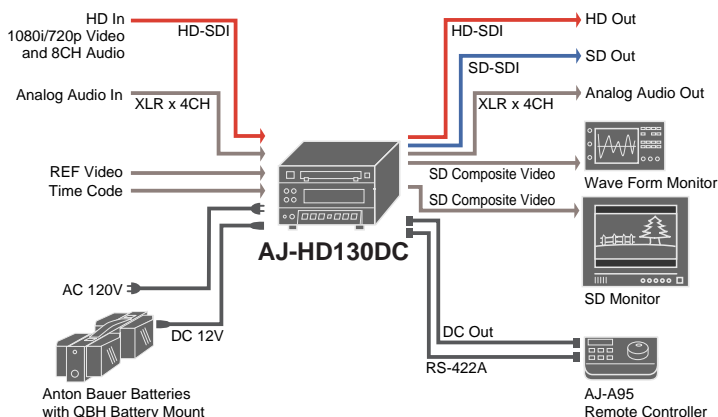

Signal In/Out and System Chart



Rear Panel



**AJ-A95**  
9-pin remote controller



**QBH**  
Anton Bauer  
Battery Mount  
and 4battery Packs



**AJ-HP46LP/  
HP32LP/HP23LP**  
DVCPRO HD  
Cassette Tapes

A J - H D 1 3 0 D C S P E C I F I C A T I O N S

General		Video Input	
Power Supply:	AC120V ±10%, 50 to 60 Hz DC12V (6.1A)	HD SDI:	BNC x 1, SMPTE 292M/296M
Power Consumption:	97W	HD/SD Reference:	HD Tri-Level SYNC (59.94 Hz) or Analog Composite BNC x 2 (loop-through), 75Ω On/Off
Operating Temperature:	41°F to 104°F (5°C to 40°C)	Video Output	
Operating Humidity:	10% to 85% (non dew)	HD SDI:	BNC x 2, SMPTE 292M/296M
Weight:	19.84 lbs (9 kg)	SD SDI:	BNC x 1 (down-convert), SMPTE 259M-C
Dimensions (WxHxD):	8-7/16" x 5-1/4" x 16-15/16" (214 x 132 x 430 mm)	Analog Composite:	BNC x 2 (down-convert), super on/off
Recording Format:	DVCPRO HD (1080i/59.94Hz, 720p/59.94Hz switchable)	Video Output Adjustment Range	
Recording Track:	Digital Video/Audio: Herical track TC: Subcode area Cue: 1 longitudinal track CTL: 1 longitudinal track	HD SDI System Phase:	±0.5H (±550 sample, 27ns step)
Tape Speed:	135.280mm/s	SD SDI/ Composite Video System Phase:	±0.5H (±429 sample, 74ns step)
Rec/Play Time:	Max. 46 minutes with AJ-HP46LP	SD SDI/ Composite Video SC Phase:	±180°
Tape:	1/4" metal particle	Audio Input	
FF/REW Time:	Less than 4 minutes with AJ-HP46LP	Analog:	XLR x 4 (CH1/2/3/4), +4/0/-20/-60 dBu switchable, 600Ω/high-impedance switchable (3KΩ of -60 dBu) factory setting; high-impedance
Video		Serial Digital:	Embedded with HD SDI (SMPTE299M)
Sampling Frequency:	Y; 74.25/1.001MHz, Pb/Pr; 37.125/1.001MHz	Audio Output	
Quantization:	8 bits	Analog:	XLR x 4 (CH1/2/3/4), +4/0/-20 dBu switchable, low-impedance, CH3/4 switchable for monitor out (L/R)
Error Correction:	Reed-solomon product code	Serial Digital:	Embedded with HD SDI (SMPTE299M) Embedded with SD SDI (SMPTE272M-A)
Compression Method:	DTC + variable length code	Headphones:	M3, variable level control, 8Ω
Compression Ratio:	6.7:1	Others	
Bit Rate:	100 Mbps	TC IN:	BNC x 1, 0.5 to 8.0 Vp-p, 10KΩ
Digital Audio		TC OUT:	BNC x 1, low-impedance, 2.0±0.5 Vp-p
Channel:	8 channels	RS-422A IN:	D-sub 9 pin RS-422A interface for AJ-A95
Sampling Frequency:	48kHz (synchronous with video)	DC OUT:	4-pin x 1, DC12V, 250 mA for AJ-A95
Quantization:	16 bits	Weight and dimensions shown are approximate. Features and specifications are subject to change without notice. These products may be subject to export regulations.	
Frequency Response:	20Hz to 20kHz, ±1.0dB (reference level)		
Dynamic Range:	More than 85dB (1kHz, emphasis off, "A" weighted)		
Distortion:	within 0.1% (1kHz, emphasis off, reference level)		
Cross Talk:	Less than -80dB (1kHz, between any 2 channels)		
Wow & Flutter:	Below measurable limit		
Headroom:	20 dB		

# Panasonic

**PANASONIC BROADCAST & TELEVISION SYSTEMS COMPANY**

DIVISION OF MATSUSHITA ELECTRIC CORPORATION OF AMERICA  
www.panasonic.com/broadcast

**Executive Office:** One Panasonic Way 4E-7, Secaucus, NJ 07094 (201) 348-5300

**EASTERN ZONE:** One Panasonic Way 4E-7, Secaucus, NJ 07094 (201)348-7196

**Central Region:** 1707 N Randall Road E1-C-1, Elgin, IL 60123 (847) 468-5200  
**WESTERN ZONE:** 3330 Cahuenga Blvd W., Los Angeles, CA 90068 (323) 436-3608

**Government Marketing Department:**  
52 West Gude Drive, Rockville, MD 20850 (301) 738-3840

**Panasonic Canada Inc.**  
5770 Ambler Drive, Mississauga, Ontario L4W 2T3 (905) 624-5010  
www.panasonic.ca e-mail: broadcast@panasonic.ca

**Panasonic Sales Company**  
(Division of Matsushita Electric of Puerto Rico Inc.)  
San Gabriel Industrial Park, 65th Infantry Ave., Km. 9.5, Carolina,  
Puerto Rico 00630 (787) 750-4300

**Matsushita Electric Industrial Co., Ltd.**  
**Systems Business Group**  
2-15 Matsuba-cho, Kadoma, Osaka, 571-8503 Japan  
Tel. 81-6-6905-4650 Fax. 81-6-6908-5969  
www.panasonic.co.jp/bsd

**Panasonic Systems Sales Taiwan Co.,Ltd.**  
5F, 2 Sec. 5 Hsin I Road Taipei, Taiwan, R.O.C  
Tel. 886-2-2725-9100 Fax. 886-2-2725-9291

**DaeHeung Multimedia Communication Corp.**  
4th Fl, Kyobo Securities Bldg., 26-4, Youngdungpo-Gu,  
Seoul, Korea Tel. 82-2-784-0245 Fax. 82-2-784-0109

**Broadcast and Communication Company of Asia, Inc.**  
R-1902A Tektite Tower II Exchange Road Ortigas Center  
Posig City, Philippines  
Tel. 63-2-633-6162 Fax. 63-2-631-1861

**Panasonic de Mexico, S.A. de C.V.**  
Tel. 52-5-488-1000 Fax. 52-5-488-1059

**Panasonic Latin America S.A.**  
(Caribe, Centro America, Venezuela, Colombia, Ecuador, Bolivia,  
Uruguay, Paraguay, Chile)  
Tel. 507-229-2955 Fax. 507-229-2536

**Panasonic del Peru S.A.**  
Tel. 51-1-451-3638 Fax. 51-1-452-9415

**Panasonic do Brasil Ltda**  
Tel. 55-11-3889-4035 Fax. 55-11-3889-4004

