

Panasonic

AJ-HD150

DVCPRO HD Studio VTR

HD HIGH DEFINITION



DVCPRO HD



1/4" DVCPRO HD Format

The new DVCPRO HD format brings DVCPRO's many advantages to HD production environments. Thanks to the small 1/4" tape and ultracompact mechanism, DVCPRO HD equipment is compact and lightweight, and running costs are low. A high-density 100-Mbps video recording system and high-efficiency compression algorithm achieve a level of picture quality.

Compact Size, Easy Installation

With its compact 4RU size, the AJ-HD150 fits into a 19-inch rack using the optional AJ-MA75P* rack mount adaptor for easy installation both in the studio and in OB vans. Its space-saving size and low power requirement can mean lower operating costs.

*Slide rail not included.

46 Minutes of High-Quality HD Recording

A video recording rate of 100 Mbps and high-efficiency compression combine to deliver superior HD images. A compact 1/4" DVCPRO HD cassette provides up to 46 minutes of high-quality recording.

1080i/720p Switchable

The AJ-HD150 handles both 1080i and 720p image formats. Users can select it at the menu.

Meta Data Recording

Adding the optional VANC board AJ-VNC150P makes it possible for the AJ-HD150 to record supplemental data (such as Meta Data or Closed Caption Data) onto the tape.

Playback of Any DVCPRO Cassette

The AJ-HD150 accommodates SDTV (480i/480p) sources, and it can play back DVCPRO, DVCPRO50, DVCPRO P, and consumer DV/Mini-DV*1 and other 1/4" DV-based format tapes. It also provides both SDI and analog (composite video and 4-channel audio) output.

*1: The AJ-HD150 cannot record on Mini-DV cassettes, even with the AJ-CS455P cassette adaptor. And the AJ-HD150 cannot play back DV/Mini-DV cassettes recorded in LP mode, or long-time Mini-DV cassettes (SP mode 80 minutes/LP mode 120 minutes).



Subpanel

Accepts a Built-In Up/Down Converter

Adding the optional HD-SD format converter board AJ-UDC150AP makes it possible for the AJ-HD150 to down-convert and output DVCPRO HD playback images as SD (480i/480p) images. It can also up-convert and output SD playback images in DVCPRO50, DVCPRO P, DVCPRO and 1/4" DV formats as HD images.

Standard with HD SDI

The AJ-HD150 comes equipped with an HD Serial Digital Interface (1.5 Gbps/SMPTE292M), for easy, reliable use with other digital HD equipment.

SDTI (Serial Data Transport Interface) System

Adding an optional board AJ-YAC150P gives the AJ-HD150 SDTI input and output capability, which lets you transfer compressed data between HD equipment with no quality loss.

ATM Transfer with a Single OC-3 Line

With the optional SDTI board AJ-YAC150P, the AJ-HD150 uses asynchronous transfer mode for DVCPRO HD data, with its 100 Mbps video recording rate, over a single OC-3 line. This makes it possible to construct a digital network at a very economical cost.

High-Quality 8-Channel Audio

The AJ-HD150 provides eight channels of 16-bit/48-kHz digital audio, which allows multi-lingual applications. There are eight channels of digital audio in/out, or four channels of analog audio in/out.

High-Speed 50x Shuttle and Jog

The AJ-HD150 provides shuttle search (both forward and reverse), fast forward and rewind at up to 50x normal speed. In jog mode you can also monitor the audio, for better accuracy and response.

Remote Control Terminals

The AJ-HD150 comes equipped with RS-422A (9-pin), RS-232C (25-pin) and parallel (50-pin) terminals for interfacing with remote operation controllers.

Other Advanced Functions

- User setting files can be uploaded/downloaded to an IC card
- 80-event cue memory
- WFM output allows monitoring of the output signal's waveform

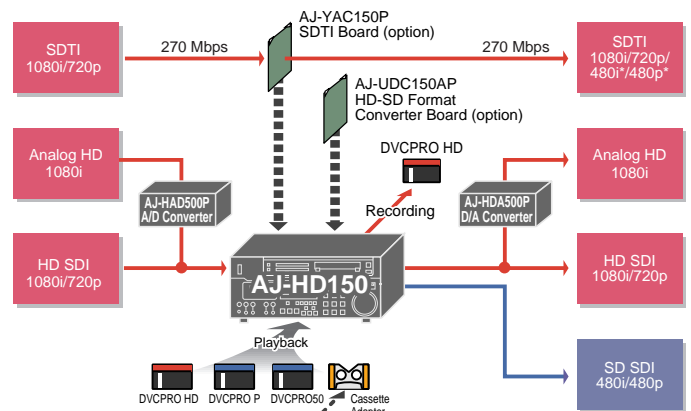

*: Playback only

Interface Chart

A Multi-Format Conversion of AJ-HD150 (with optional AJ-UDC150AP)

Playback Tape	Format	Output Signals		
		HD-SDI	SDI	Video Out
DVCPRO HD	1080i	1080i	480i/480p	480i
		720p	—	—
	720p	1080i	—	—
		720p	480i/480p	480i
DVCPRO P	480p	1080i	480p	480i
		720p	480p	480i
	—	—	480i	480i
		—	—	480i
DVCPRO50 DVCPRO 1/4" DV-based Format	480i	1080i	480i	480i
		720p	480i	480i
	—	—	480p	480i
		—	—	480p



Rear Panel

A J - H D 1 5 0 S P E C I F I C A T I O N S

General

Power Supply:	AC120V ±10%, 50 to 60 Hz
Power Consumption:	230W
Operating Temperature:	41 °F to 104 °F (5°C to 40°C)
Operating Humidity:	10% to 90% (non dew)
Weight:	44 lbs (20 kg)
Dimensions (WxHxD):	16-11/16" x 6-7/8" x 17-3/4" (424 x 175 x 450 mm)
Recording Format:	DVCPRO HD (1080/59.94i, 720/59.94p)
Recording Track:	Digital Video: 1080i/720p Digital Audio: 8 channels TC: Subcode area Cue: 1 longitudinal track CTL: 1 longitudinal track
Tape Speed:	135.280mm/s (1080i/720p)
Rec/Play Time:	Max. 46 minutes with AJ-HP46LP
Tape:	1/4" metal particle
FF/REW Time:	Less than 3 minutes with AJ-HP46LP
Search Speed:	±50x (in color)
Editing Accuracy:	±0 frame (TC)
Tape Timer Accuracy:	±1 frame (continuous CTL)
Servo Lock Time:	Within 0.5 sec (standby ON)
Loading/Unloading Time:	Approx. 3 sec

Video

Quantization:	8 bits
Error Correction:	Reed Solomon Product Code
Compression Ratio:	6.7:1
Bit Rate:	100 Mbps

Digital Audio

Channel:	8 channels
Sampling Frequency:	48kHz
Quantization:	16 bits
Error Correction:	Reed-solomon product code
Frequency Response:	20Hz to 20kHz, ±1.0dB (reference level)
Dynamic Range:	More than 90dB (1kHz, "A" weighted)
Distortion:	within 0.05% (1kHz, reference level)
Cross Talk:	Less than -80dB (1kHz, between any 2ch)
Wow & Flutter:	Below measurable limit
Headroom:	20 dB

Cue Audio

Frequency Response:	300Hz to 6kHz (±3dB)
---------------------	----------------------

Video Input

HD SDI:	BNC x 1, SMPTE 292M
HD Reference:	BNC x 2 (loop-through), 75Ω On/Off
SD Reference:	BNC x 2 (loop-through), 75Ω On/Off
SDTI (option):	BNC x 1, SMPTE 305M

Video Output

HD SDI:	BNC x 3 (OUT3: Super on/off), SMPTE 292M
SD SDI:	BNC x 3 (OUT3: Super on/off), SMPTE 259M-C/SMPTE 294M
HD Reference Sync:	BNC x 1
SD Reference Sync:	BNC x 1
SDTI (option):	BNC x 1, SMPTE 305M
Analog Composite:	BNC x 3 (SD playback or down-convert) OUT2: switchable for WFM OUT OUT3: super on/off

Audio Input

Analog:	XLR x 4 (CH1/2/3/4), +4/0/-20 dBu switchable, 600Ω/high-impedance switchable
Digital:	BNC x 4 (CH1/2, CH3/4, CH5/6, CH7/8), AES/EBU
Serial Digital:	Embedded with HD SDI
Cue:	XLR x 1, +4/0/-20/-60 dBu switchable, Low-impedance

Audio Output

Analog:	XLR x 4 (CH1/2/3/4), +4/0/-20 dBu switchable, 600Ω/high-impedance switchable
Digital:	BNC x 4 (CH1/2, CH3/4, CH5/6, CH7/8), AES/EBU
Serial Digital:	Embedded with HD SDI, Embedded with SD SDI
Cue:	XLR x 1, Low-impedance, +4/0/-20 dBu switchable
Monitor:	XLR x 2 (L/R), Low-impedance, +4/0/-20 dBu switchable
Phones:	M6, variable level control, 8Ω

Others

TC IN:	XLR x 1, 0.5 to 8.0 Vp-p
TC OUT:	XLR x 1, 2.0 Vp-p
RS-422A IN/OUT:	D-sub 9 pin RS-422A I/F
RS-422A OUT:	D-sub 9 pin RS-422A I/F
RS-232C:	D-sub 25 pin RS-232C I/F
Parallel IN/OUT:	D-sub 50 pin
Encoder Remote:	D-sub 15 pin

Options

HD-SD Format Converter:	AJ-UDC150AP
SDTI Board:	AJ-YAC150P
VANC Board:	AJ-VNC150P
Video Controller:	AJ-A900
Rack Mount Adaptor:	AJ-MA75P (for DVCPRO series)

Weight and dimensions shown are approximate.
Features and specifications are subject to change without notice.
These products may be subject to export regulations.

Panasonic

PANASONIC BROADCAST & TELEVISION SYSTEMS COMPANY

DIVISION OF MATSUSHITA ELECTRIC CORPORATION OF AMERICA
www.panasonic.com/broadcast

Executive Office: One Panasonic Way 4E-7, Secaucus, NJ 07094
(201) 348-5300

EASTERN ZONE: One Panasonic Way 4E-7, Secaucus, NJ 07094
(201)348-7196

Central Region: 1707 N Randall Road E1-C-1, Elgin, IL 60123 (847) 468-5200
WESTERN ZONE: 3330 Cahuenga Blvd W., Los Angeles, CA 90068
(323) 436-3608

Government Marketing Department:

52 West Gude Drive, Rockville, MD 20850 (301) 738-3840

Panasonic Canada Inc.

5770 Ambler Drive, Mississauga, Ontario L4W 2T3 (905) 624-5010
www.panasonic.ca e-mail: broadcast@panasonic.ca

Panasonic Sales Company

(Division of Matsushita Electric of Puerto Rico Inc.)
San Gabriel Industrial Park, 65th Infantry Ave., Km. 9.5, Carolina,
Puerto Rico 00630 (787) 750-4300

Matsushita Electric Industrial Co., Ltd. Systems Business Group

2-15 Matsuba-cho, Kadoma, Osaka, 571-8503 Japan
Tel. 81-6-6905-4650 Fax. 81-6-6908-5969

www.panasonic.co.jp/bsd

Panasonic Systems Sales Taiwan Co., Ltd.

5F, 2 Sec. 5 Hsin I Road Taipei, Taiwan, R.O.C
Tel. 886-2-2725-9100 Fax. 886-2-2725-9291

DaeHeung Multimedia Communication Corp.

4th Fl, Kyobo Securities Bldg., 26-4, Youngdungpo-Gu,
Seoul, Korea Tel. 82-2-784-0245 Fax. 82-2-784-0109

Broadcast and Communication Company of Asia, Inc.

R-1902A Tektite Tower II Exchange Road Ortigas Center
Posig City, Philippines
Tel. 63-2-633-6162 Fax. 63-2-631-1861

Panasonic de Mexico, S.A. de C.V.

Tel. 52-5-488-1000 Fax. 52-5-488-1059

Panasonic Latin America S.A.

(Caribe, Centro America, Venezuela, Colombia, Ecuador, Bolivia,
Uruguay, Paraguay, Chile)
Tel. 507-229-2955 Fax. 507-229-2536

Panasonic del Peru S.A.

Tel. 51-1-451-3638 Fax. 51-1-452-9415

Panasonic do Brasil Ltda

Tel. 55-11-3889-4035 Fax. 55-11-3889-4004

