



Vinten

Freeing your creativity

Perfect Balance for effortless camera operation

Camera Support Systems 2013/2014

A professional video camera is mounted on a black tripod. The camera is positioned in the lower right quadrant of the frame. In the background, a light-colored wall is visible with a blue ribbon that flows across the top of the image, creating a sense of movement and elegance. The overall scene is clean and professional.

Vinten's wide range of studio and OB camera support equipment gives camera operators **effortless support** that frees them to **maximise creativity** and focus on that perfect moment.

Contents

Every year thousands of iconic television productions across the globe are filmed using cameras supported by **Vinten** pan and tilt heads, pedestals and tripods.



Above: Vinten: chosen for silky smooth, flawless support

Collaboration with world famous broadcasters, cameramen and professional videographers over decades has driven Vinten's unique, pioneering technology:

- Infinitely adjustable **Perfect Balance** so that the camera feels weightless for the camera operator
- Infinitely adjustable **Lubricated Friction (LF) and Thin Film (TF) Drag** enable continuous drag adjustment so that the camera moves in tune with you.

Vinten is the de facto standard for studio and outdoor broadcasters. As the premium camera support brand, every Vinten is backed by global sales and service.



www.vinten.com/en/vinten-story

Contents

The Vinten Difference

Broadcast Performance	6
Perfect Balance Technology	7
Lubricated Friction Drag Technology	19
Tripod Rigidity	27
Thin Film Drag Technology	33
Service and Support	50
Vinten Online Parts Store	33
Free Warranty Extension	52-53
System Guides	

Vision blue Systems

Payload 1.5kg to 12kg / 3.5lbs to 25lbs	4-9
Vision blue Range Introduction	5
Vision blueBridge	8
Vision blue Systems	9
Vision blue/blue3/blue5	
Range Specifications	9

Vision Lightweight Systems

Payload to 33kg / 72.8lbs	10-17
Vision Head Range Specifications	11
Vision 8AS	12-13
Vision 10AS	12-13
Vision 100	14-15
Vision 250	16-17

Tripods, Spreaders and Dollies

18-25	
Pozi-Loc Tripods (payload to 55kg / 121lbs)	18-21
Heavy Duty Tripods (payload to 140kg / 308.6lbs)	22-23
Spreaders	24
Skids/Dollies (payload to 160kg / 353lbs)	25
Tracking Skids	25

Studio/OB Heads

Payload to 120kg / 264.5lbs	26-31
Vector 430 & 430S	28
Vector 75	29
Vector 750	30
Vector 950	31

Studio/OB Pedestals

Payload to 105kg / 231.5lbs	32-40
Vision Ped Plus	34
Pro-Ped Pedestal	35
Osprey Light	36
Osprey Elite	37
Quartz One & Two	38
Quattro-L and Quattro-OBL	39
Quattro-SL	40

Virtual/Augmented Reality

Payload to 75kg / 165.3lbs	41-46
Vector 430i	42
Vector 750i	43
Vector 950i	44
Virtual Reality Interface Box	45
Quattro-SE	46

Adaptors and Accessories

48-51	
System Guides	52-53

Contact us

54	
-----------	--

Visit www.vinten.com for the latest news, videos and user stories. Become a fan on Facebook www.facebook.com/vintenlive Follow us on Twitter [@vinten_live](https://twitter.com/vinten_live)



Introducing the award winning Vision blue family





Combining perfect balance with precisely adjustable drag to match your style.
Freeing your creativity.

Award winning

The award winning **Vision blue** head and tripod systems deliver effortless support, freeing you to focus on your creative edge. With the widest payload capacity in each class, the perfect balance and drag control can be adapted for cameras from just 1.5kg with the new **blueBridge**, up to 12kg/26.5lb, for heavier combinations.

Whichever system you choose, each pan and tilt head is effortless to use, providing perfect balance and precisely adjustable drag to exactly match your style.

Based upon the technology used by broadcasters around the globe, Vinten Vision blue systems offer outstanding quality of camera support. Each Vision blue head is the only product in its class to offer infinitely adjustable Perfect Balance and Lubricated Friction (LF) drag technology, freeing you to focus on getting the best from your camera.

Freeing you to focus on the filming, the award winning **Vision blue head** and tripod systems deliver effortless support.

The Vision blue range

- **Effortless camera operation** – perfect counterbalance adjustment
- **Moves in tune with you** – infinite drag settings
- **Built to last** – precision engineered parts, designs based upon broadcast industry expertise
- **Adapts to many cameras** - widest payload capacity in each class:

Vision blue from 1.5kg @55mm CofG
Vision blue3 from 2.1kg @55mm CofG
Vision blue5 up to 12kg (26.5lb) @100mm CofG

“The performance of the head is **flawless**. The usual Vinten silky smooth pan and tilt starts and stops, **superb** constant velocity movement in any axis and not a hint of pullback at pan ends. In short, as perfect as I can ever imagine any head being.”

Chris Soucy, New Zealand, reviewing the Vision blue



Perfect Balance for Unrivalled, Effortless Camera Operation

Vinten's unique infinitely adjustable **Perfect Balance** system makes heavy broadcast **cameras appear weightless** in the hands of the operator. It has made Vinten the de facto studio and OB camera support.



Above: Perfect Balance - free to focus on the shot



Above: Dial in Perfect Balance

"The amazing Perfect Balance system on the **blue5** allowed me to dial in **precise control** for smooth movement without any surprises."

Tom Guilmette
Sports camera operator and director of photography



www.vinten.com/en/vinten-tv

Perfect Balance delivers:

- **Minimal effort** is required to move the camera; the camera operator can even go hands-free
- **Consistent movement** and easy positioning of the camera at any angle
- **Perfect shots** captured
- Physical strain reduced so it is easy to **work longer**.

Vinten's **unrivalled broadcast technology is also available to pro-videographers** who expect the best camera support, freeing them to focus on getting the best from their camera.

Vintens Perfect Balance pedestals:

- Ensure that pedestals can be **moved effortlessly** and one positioned will stay put, whatever the weight of the camera configuration
- Provides slow, low effort elevation movements with **no distraction from filming** caused by unwanted vertical movement
- Physical strain reduced so it is easy to work longer.

Competitor 1 linear counterbalance system

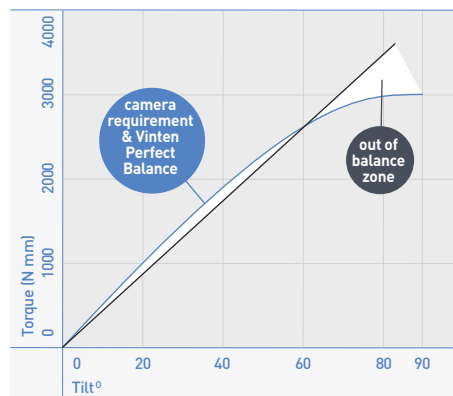

Competitor 2 approximate counterbalance system

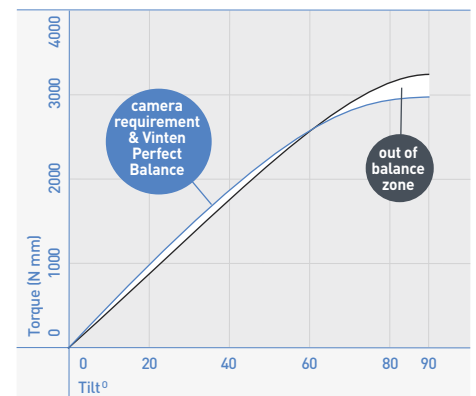

Above: When a camera is out of balance, it will drift.

Vinten's Lubricated Friction (LF) Drag Technology Precisely matches the way you work

Each Vinten pan and tilt head is **effortless** to use, providing **perfect balance** and precisely adjustable drag to exactly match your style.

LF Drag: the camera moves in tune with you

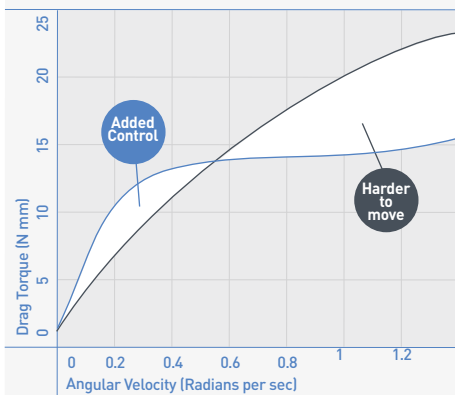

“The big advantage of this technology is that I could **capture perfect shots with minimal effort** and have easy and consistent movement of the camera throughout the tilting range. I simply dialled in the amount of drag I needed, and this is adjustable, so it enabled me to maintain precise control over the camera.”

Derran Rootring, Netherlands,
Independent Film Maker reviewing Vision blue3

Below: Capture the action with controlled whip pan



To help achieve the best possible filming, Vinten's Lubricated Friction (LF) drag technology (resistance to movement):

- Provides simple, continuous adjustment of drag level that **suits the way you work** instead of a pre-determined level which may not
- Helps prevent overshooting
- Dampens out unwanted movements and makes minor adjustment virtually impossible to detect
- Instant, controlled whip pan movement without manual drag reduction.



Vision blue

Freedom rewarded

Bridging the gap

The new **Vision blueBridge** accessory extends the lower range of payloads for each Vision blue system. Quickly and simply attaching to the underside of the camera, it raises the camera above the platform allowing lower weight cameras to be used that would otherwise be too light for the counterbalance system to balance perfectly.



In tune with you

By teaming the Vision blue heads with the Pozi-Loc tripod and Vinten carry case, you'll have the perfect support for your business. The Pozi-Loc's design excellence is felt throughout, starting with the excellent torsional rigidity which minimises spring back. It will perform, whatever the conditions. For more information about the Pozi-Loc, see page 19.

Match Vision blue to your camera...



www.vinten.com/en/what-camera-which-head

Below: Vision blueBridge extends the payload capacity



Discover **blueBridge**.
Watch the video...



www.vinten.com/en/vinten-tv

"I have been a great fan of Vinten for a long time. They have consistently given me the technology and the **reliability of performance** that I need to operate as a freelance professional."

Laurie Gilbert,
Director of Photography



Product specifications	Vision blue	Vision blue3	Vision blue5
Capacity Range	2.1 to 5.0kg / 4.6 to 11.0lbs @ approx. 55mm CofG	3.0 to 6.6kg / 6.6 to 14.6lbs @ approx. 55mm CofG	5.5 to 12kg / 12 to 26lbs @ approx. 100mm CofG
Capacity Range with Vision blueBridge	1.5 to 5.0kg / 3.3 to 11.0lbs @ approx. 55mm CofG	2.1 to 6.6kg / 4.6 to 14.6lbs @ approx. 55mm CofG	4.2 to 12kg / 9.2 to 26lbs @ approx. 100mm CofG
System height range with Pozi-Loc tripod (floor spreader)	55-169cm (22-66")		
System transport length (floor spreader)	85cm (33.5")		
Tilt range	±90°		
Counter balance	Infinitely adjustable Perfect Balance		
Drag	Calibrated infinitely adjustable LF drag system		
Ball base	75mm		
Camera fixing	Standard Vision AS two-way sliding plate with one 1/4" camera screw and pin		
Levelling bubble	Illuminated high contrast blue LED		
Pan Bar	Single fixed length		
Temperature range	-15 to +30°C		
Floor spreader system weight with optional Vision blueBridge	6.9kg/15.2lbs incl. pan bar, camera plate, bowl clamp and Vision blueBridge		
Mid level spreader system weight with optional Vision blueBridge	6.5kg/14.3lbs incl. pan bar, camera plate, bowl clamp and Vision blueBridge		
Package Options			
Head only	V4092-0001 Stand alone Vision blue head	V4106-0001 Stand alone Vision blue3 head	V4105-0001 Stand alone Vision blue5 head
End entry camera plate supplied with 1/4" screw and pin assembly, additional 1/4" screw and 2 x 3/8" camera screws, fixed length pan bar, bowl clamp knob and multi-language operator guide.			
System with floor spreader	VB-AP2F • 1 x Vision blue head (V4092-0001) • 1 x Two stage aluminium Pozi-Loc tripod (3819-3)	VB3-AP2F • 1 x Vision blue3 head (V4106-0001) • 1 x Floor Spreader (3363-3)	VB5-AP2F • 1 x Vision blue5 head (V4105-0001) • 1 x Soft Case (3358-3)
System with Mid level spreader	VB-AP2M • 1 x Vision blue head (V4092-0001) • 1 x Two stage aluminium Pozi-Loc tripod (3819-3)	VB3-AP2M • 1 x Vision blue3 head (V4106-0001) • 1 x LW Mid-Level Spreader (V4032-0001)	VB5-AP2M • 1 x Vision blue5 head (V4105-0001) • 1 x Soft Case (3358-3)
Vision blueBridge camera adapter	V4106-1003 • 1 x Small camera adapter (V4106-2004) • 1 x 1/4" screw and pin assy (V4045-1006) • 1A/R Oring (Q001-093)		

Vision blue balance graph

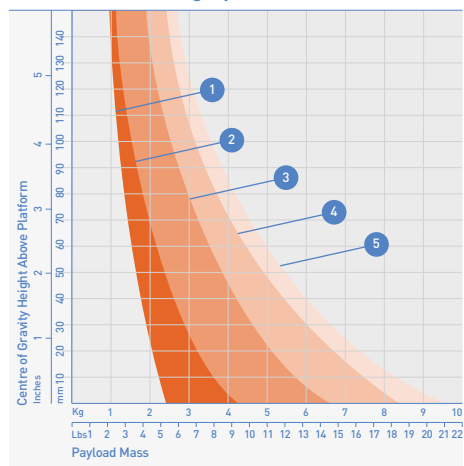

Vision blue3 balance graph

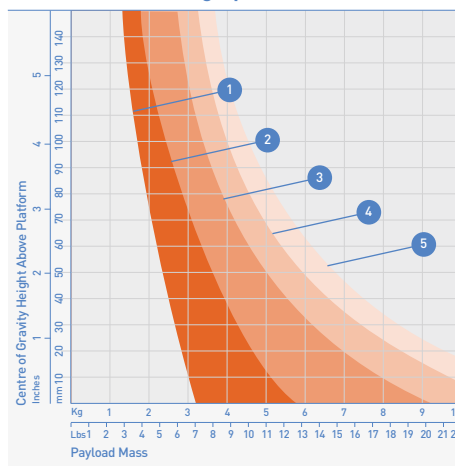

Vision blue5 balance graph

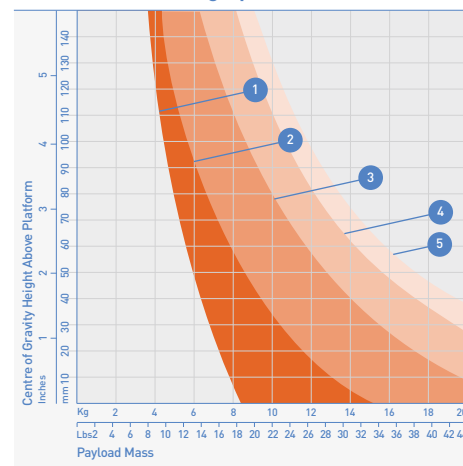







Key: 1. with blueBridge 2. minimum 3. max 90° 4. max 60° 5. max 40°

Vision Lightweight Heads and Systems



Vision Head Range Quick Reference Chart

Specification	Vision 8AS	Vision 10AS	Vision 100	Vision 250
Part No	V4045-0001	V4046-0001	3466-3	V3465-3S / V3465-3F
 Capacity Range	5.5 to 14kg @ 100mm 12.1 to 30.9lbs	6.5 to 17kg @ 100mm 14.3 to 37.5lbs	7 to 19kg @ 100mm 15.4 to 42lbs	5 to 30kg @ 100mm 11 to 66lbs
 Head weight	3.1kg / 6.8lbs	3.2kg / 7lbs	3.2kg / 7.1lbs	6.1kg / 13.5lbs
 Maximum tilt range	±90°	±90°	±90°	±90°
Infinite adjustment (drag/balance)	Y / Y	Y / Y	Y / Y	Y / Y
Drag Type	LF	LF	TF	TF
 Ball Base	100mm	100mm	100mm	Dual 100 / 150mm / Flat
 Camera Fixing	Quick attachment and release Sideload system, utilising a standard slide plate complete with captive 1/4" pin and 2 x 3/8" screws			Removable sliding plate with 2 x 3/8" fixing screws
 Illuminated level bubble	Y (blue)	Y (blue)	Y (amber)	Y (amber)
 Pan Bar	Single fixed length	Single telescopic	Single fixed length	Single telescopic
System details page	13	13	15	17

The award winning Vision range of pan and tilt heads is used by professionals around the world wanting the **premium broadcast** quality only available from Vinten.

“The **smoothness** of this head is lovely with no sudden slips or tight spots, it’s a pleasure to use.”

Alister Chapman
reviewing the Vision 100



Above: TF drag systems operates at -40°C

- **Vinten’s legendary, premium broadcast performance** for lightweight cameras from the market leader
- **Vinten’s unique combination** of continuous counterbalance and drag to precisely match you style for creative freedom
- **Robust**, designed to last
- **Sympathetically designed** with decades of broadcast experience to provide quick, accurate set up

Key to Symbols:

-  Height
-  Transport Length
-  Length
-  Weight
-  Width
-  Capacity Range

Vision 8AS & 10AS

Vision 8AS & 10AS are **perfect** for all professional broadcast productions where larger batteries, small viewfinders and small LCD prompters are constantly swapped.



Vision 8AS is ideal for professionals using the latest **portable camera** configurations.

The **Vision 10AS** is an extremely cost effective solution for **professional broadcast products** from documentary shoots to breaking news coverage.

Below: High contrast blue LED level bubble illumination



8AS Balance Chart

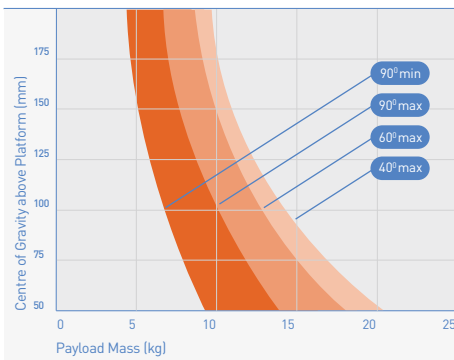

10AS Balance Chart

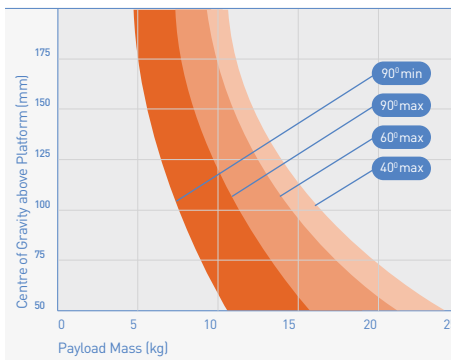

Vision 8AS Systems

Aluminium	V8AS-AP1F	V8AS-AP1M	V8AS-AP2F	V8AS-AP2M
Capacity Range	5.5 to 14kg / 12.1 to 30.9lbs			
Tripod Part No (1 or 2 stage)	Single Stage (V3823-0001)		Two Stage (3821-3)	
Weight	8.3kg / 18.3lbs		8.5kg / 18.7lbs	
System Height Range	77.8 - 160.2cm / 30.6 - 63.1"		57.4 - 172.5cm / 22.6 - 67.9"	
Transport Length	100cm / 40.4"		86.6cm / 34.1"	
Spreader Choice	Floor (3363-3)	Mid-Level (3781-3)	Floor (3363-3)	Mid-Level (3781-3)
Soft Case	(3334-3)		(3358-3)	
Carbon Fibre	V8AS-CP1F	V8AS-CP1M	V8AS-CP2F	V8AS-CP2M
Capacity Range	5.5 to 14kg / 12.1 to 30.9lbs			
Tripod Part No (1 or 2 stage)	Single Stage (3773-3)		Two Stage (3772-3)	
Weight	7.7kg / 17lbs		8kg / 17.4lbs	
System Height Range	77.8 - 160.2cm / 30.6 - 63.1"		57.4 - 172.5cm / 22.6 - 67.9"	
Transport Length	100cm / 40.4"		86.6cm / 34.1"	
Spreader Choice	Floor (3363-3)	Mid-Level (3781-3)	Floor (3363-3)	Mid-Level (3781-3)
Soft Case	(3334-3)		(3358-3)	

Vision 10AS Systems

Specification	V10AS-AP2F	V10AS-AP2M	V10AS-CP2F	V10AS-CP2M
Capacity Range	6.5 to 17kg / 14.3 to 37.5lbs			
Tripod	Pozi-Loc Two Stage			
Material Choice	Aluminium (3821-3)		Carbon Fibre (3772-3)	
Weight	8.6kg / 18.9lbs		8.1kg / 17.7lbs	
System Height Range	57.4 - 172.5cm / 22.6 - 67.9"			
Transport Length	86.6cm / 34.1"			
Spreader Choice	Floor (3363-3)	Mid-Level (3781-3)	Floor (3363-3)	Mid-Level (3781-3)
Soft Case	(3358-3)			

Key to Diagrams

1. Side load release
2. Slide plate clamp
3. Tilt brake lever
4. Pan brake lever
5. Illuminated levelling bubble
6. Pan drag control
7. Tilt drag control
8. Pan bar mounting
9. Slide plate
10. Ball base clamp
11. Battery compartment
12. 3/8" screws
13. Slide plate scale
14. Camera screw storage
15. Perfect balance knob

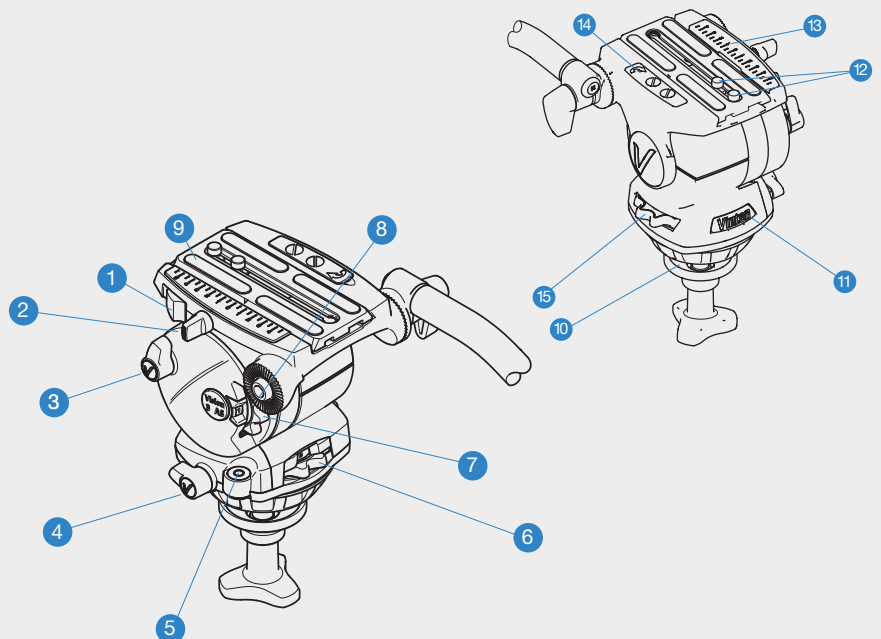

Vision 100



Illuminated drag controls for easy, precise set up

Extensive operating temperature from -40°C to $+60^{\circ}\text{C}$ for consistent performance in the toughest conditions

Robust construction designed to last

Repeatable balance settings for quick and simple camera setup

Perfect Balance and TF Drag for uncompromising camera control

The Vision 100 allows total control and consistent performance in the **toughest conditions.**

Balance Chart

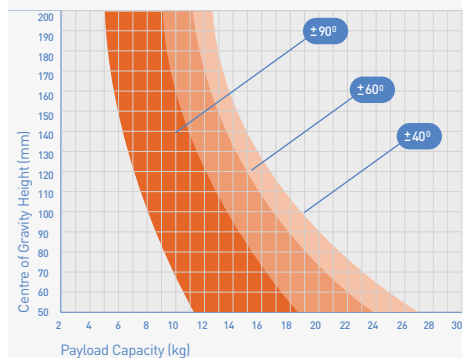

Vision 100 is perfect for all professional ENG or EFP situations that demand total **reliability** and **control** excellence regardless of the environment.

Combining Vinten's unique combination of Perfect Balance with the patented, infinite control TF drag system (see page 27), the Vision 100 works exactly in tune with you for uncompromising camera control.



Above: Digital balance read out for quick set up with multiple cameras



Vision 100

Specification	VB100-AP2	VB100-AP2M	VB100-CP2	VB100-CP2M
Capacity Range	7 to 20kg / 15.4 to 44.1lbs			
Tripod	Pozi-Loc Two Stage			
Material Choice	Aluminium (3821-3)		Carbon Fibre (3772-3)	
Weight	10.6kg / 23.4lbs		10.1kg / 22.2lbs	
System Height	56.7 - 171.8cm / 22.3 - 67.6"			
Transport Length	85.9cm / 33.8"			
Spreader	Floor (3363-3)	Mid-Level (3781-3)	Floor (3363-3)	Mid-Level (3781-3)
Soft Case	(3340-3)			

Key to Diagrams

1. 3/8" screws
2. Pan bar rosette
3. Digital display
4. Illuminated level bubble
5. Ball base and clamp
6. Pan brake lever
7. Tilt drag control
8. Tilt brake lever
9. Slide plate lock
10. Slide plate
11. Slide plate clamp
12. Pan bar clamp
13. Pan drag control
14. Battery compartment
15. Illumination switch
16. Perfect Balance knob

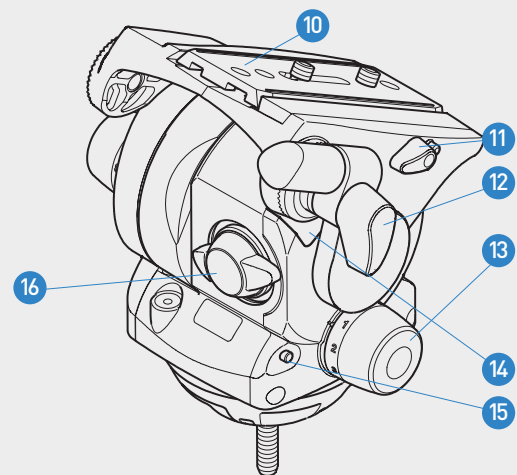
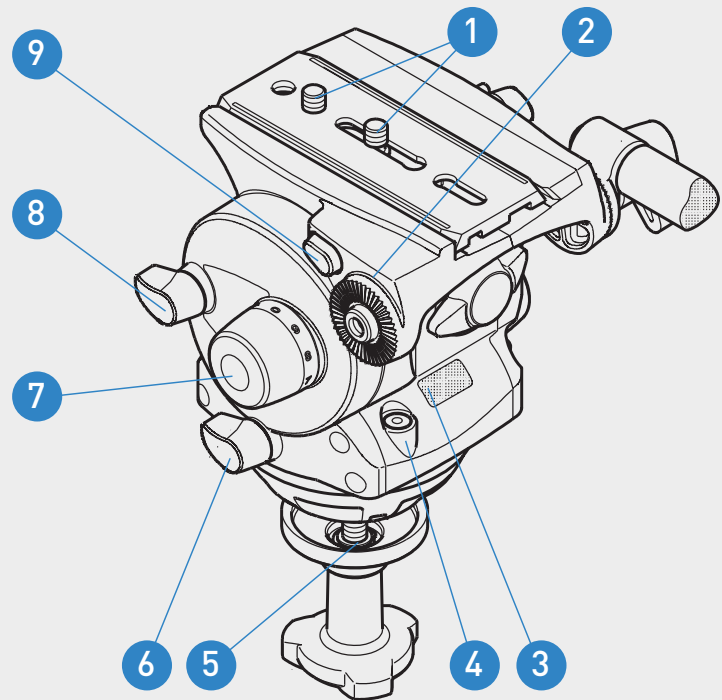

Vision 250



The Vision 250 is **the standard** in new **studio production** as well as OB/EFP applications.

Balance Chart

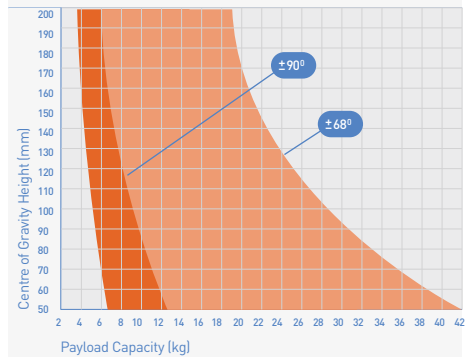

“Vinten’s superior engineering allows our operators to fine-tune the counterbalance and friction quickly and to exacting standards.”

Christian La Fontaine
Director of Photography

With a choice of easily changeable spherical or flat bases, the Vision 250 can be mounted on any pedestal or tripod, making the Vision 250 head one of the most versatile products in the range.

The TF drag system (see page 27) offers infinite adjustment and because it works independently of the balance system, allows precision balancing of the pan and tilt axis so that the effort needed to follow the action becomes totally insignificant.

The Vision 250 also includes illuminated drag controls and a digital counterbalance readout, ensuring simple and repeatable camera set-up in any lighting situation.







Above: Tilt centrelock for safety with high payloads



Vision 250 Head

Specification (also see page 11)	250 with Dual 100 mm / 150 mm Ball Base	250 with Quickfix / 4-Bolt Flat Base
Part No	V3465-3S	V3465-3F
 Ball Base	Dual 100 / 150mm	The Ball Base and Quickfix / 4-Bolt Flat Base can be purchased as an accessory to make your system totally flexible: 3525-900SP Ball Base 3525-901SP 4-bolt flat base / Quickfix

Vision 250 Systems

Specification	VB250-AP2	VB250-AP2M	VB250-CP2	VB250-CP2M
 Capacity Range	5 to 30kg / 11 to 66lbs			
Tripod	Pozi-Loc Two Stage			
Material Choice	Aluminium (V4086-0001)		Carbon Fibre (3881-3)	
 Weight	17.3kg / 38.1lbs		16.9kg / 37.3lbs	
 System Height	68.3 - 172.7cm / 26.9 - 68"			
 Transport Length	92cm / 36.2"			
 Pan Bar	Dual Telescopic (3219-91)			
Spreader Choice	Floor (3363-3)	Mid-Level (3781-3)	Floor (3363-3)	Mid-Level (3781-3)
Soft Case	[3341-3]			

Key to Diagrams

1. Pan bar rosette
2. Slide plate
3. 3/8" screws
4. Perfect Balance knob
5. Centre lock
6. Flat base with Quickfix and standard four-hole fixing
7. Illuminated level bubble
8. Digital display and light sensor
9. Illumination switch
10. Tilt drag control
11. Pan brake lever
12. Tilt brake lever
13. Slide plate lock
14. Pan bar clamp
15. Slide plate clamp
16. Battery compartment
17. Ball base and clamp
18. Pan drag control

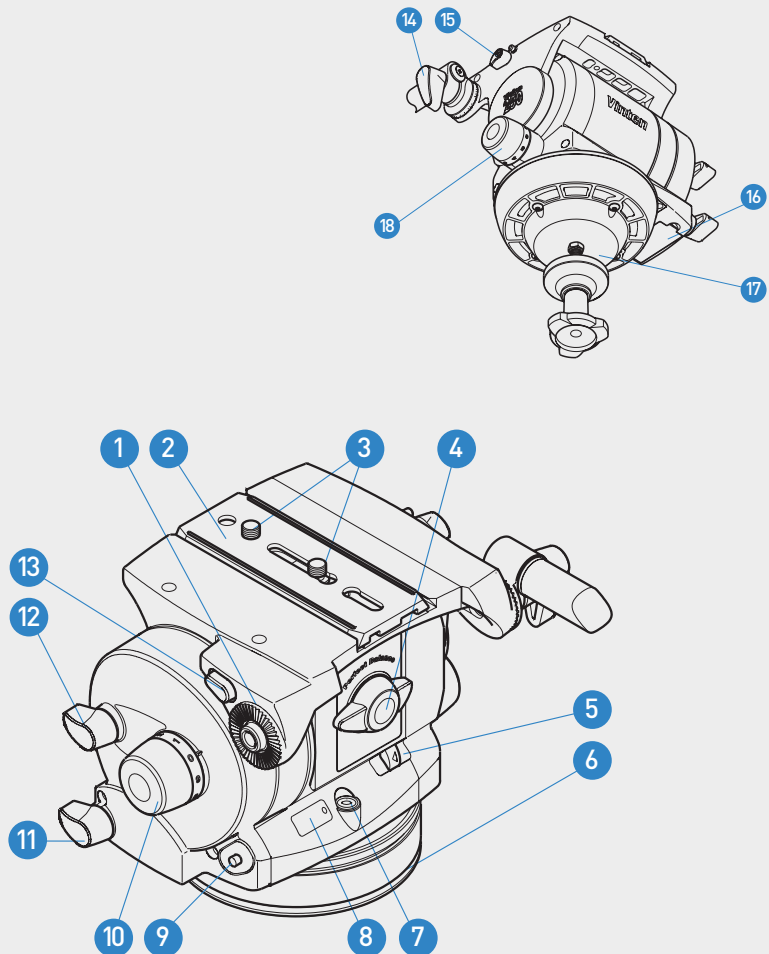



Litepanels



Innovative products around the camera

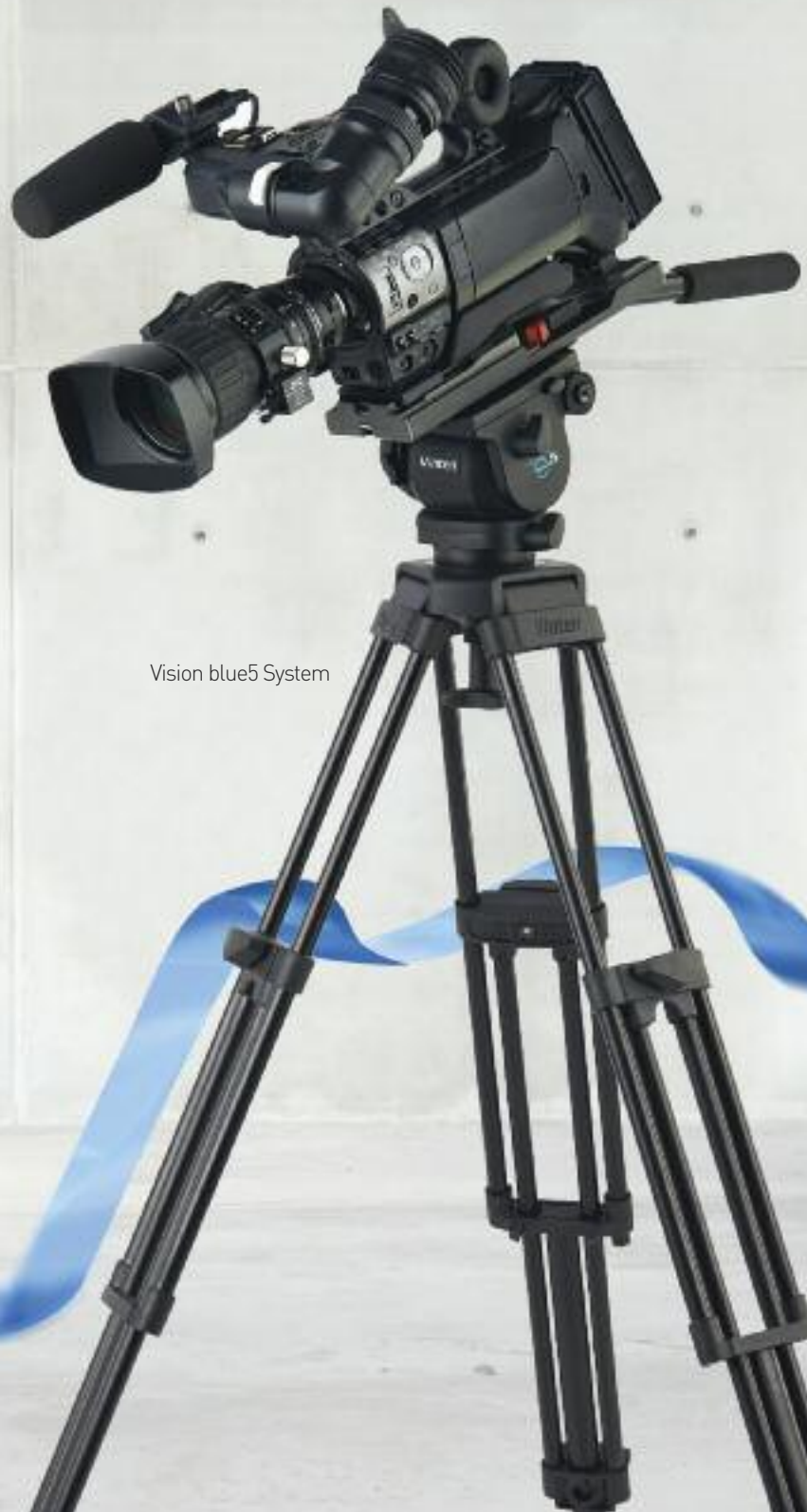

Vision blue5 System



Petrol Bag

www.vitecvideocom.com

 Vitec Videocom
A Vitec Group division

 **VITEC** Videocom



The Vinten Difference

Pozi-Loc Tripods

Picture quality relies as much upon the **rigidity** of the camera support as it does on the smoothness of the pan and tilt head and accuracy of the counterbalance.



Above: Ideal for harsh environments



Above: Engineered for reliability

Vinten offer a range of Pozi-Loc tripods (pages 19 to 21) that are designed to achieve optimum picture quality for those shooting with lightweight camera configurations, as well as Heavy Duty tripods (pages 22 to 23) that make the perfect shot possible with heavier camera configurations up to 140kg / 308.6lbs.

All Vinten tripods are precisely manufactured using the highest quality materials and are designed to optimise torsional rigidity without compromising operational essentials such as lightweight, reliability, easy, maintenance and speed of set-up.

Watch the video about torsional rigidity



www.vinten.com/en/vinten-tv



Key to Symbols:

-  Height
-  Length
-  Width
-  Transport Length
-  Weight
-  Capacity Range

Pozi-Loc tripods are designed to achieve **optimum picture quality** for those shooting with lightweight camera configurations.



Single Stage

Two-Stage

Two-Stage EFP

Baby Leg

Pozi-Loc Tripods

Single-Stage Pozi-Loc Tripod

V3823-0001
Aluminium with 100mm bowl

V3822-0001
Aluminium with 75mm bowl

3773-3
Carbon Fibre with 100mm bowl

3777-3
Carbon Fibre with 75mm bowl

Two-Stage Pozi-Loc Tripod

3821-3
Aluminium with 100mm bowl

3819-3
Aluminium with 75mm bowl

3772-3
Carbon Fibre with 100mm bowl

3776-3
Carbon Fibre with 75mm bowl

Two-Stage EFP Pozi-Loc Tripod

V4086-0001
Aluminium with 150mm bowl

V4087-0001
Aluminium with 100mm bowl

3881-3
Carbon Fibre with 150mm bowl

3884-3
Carbon Fibre with 100mm bowl

Baby Leg Pozi-Loc Tripod

3779-3
Aluminium two-stage
ENG with 75mm bowl

3778-3
Aluminium two-stage ENG
with 100mm bowl

3882-3
Aluminium two-stage EFP
with 150mm bowl

Available in the following variations:

The Pozi-Loc clamping system provides a **positive indication** that the tripod is **securely** locked.

Pozi-Loc Tripod Reference Chart

Part No	Minimum Height with Floor Spreader	Maximum Height with Floor Spreader	Weight	Recommended Maximum Load	Transport Length	Carrying Strap
75 mm Bowl Pozi-Loc Tripods						
3819-3 Two-stage Aluminium ENG	41.6cm / 16.4"	156.2cm / 61.5"	3.2kg / 7lbs	25kg / 55lbs	71cm / 28"	Optional
V3822-0001 Single-stage Aluminium ENG	64.7cm / 25.5"	145.5cm / 57.3"	2.8kg / 6.2lbs	25kg / 55lbs	86.4cm / 34"	Optional
3776-3 Two-stage Carbon Fibre ENG	41.6cm / 16.4"	156.2cm / 61.5"	2.6kg / 5.6lbs	25kg / 55lbs	71cm / 28"	Optional
3777-3 Single-stage Carbon Fibre ENG	64.7cm / 25.5"	145.5cm / 57.3"	2.3kg / 5lbs	25kg / 55lbs	86.4cm / 34"	Optional
100 mm Bowl Pozi-Loc Tripods						
3821-3 Two-stage Aluminium ENG	41.6cm / 16.4"	156.2cm / 61.5"	3.1kg / 6.8lbs	25kg / 55lbs	71cm / 28"	Optional
V3823-0001 Single-stage Aluminium ENG	64.7cm / 25.5"	145.5cm / 57.3"	2.8kg / 6.2lbs	25kg / 55lbs	86.4cm / 34"	Optional
3772-3 Two-stage Carbon Fibre ENG	41.6cm / 16.4"	156.2cm / 61.5"	2.6kg / 5.7lbs	25kg / 55lbs	71cm / 28"	Optional
3773-3 Single-stage Carbon Fibre ENG	64.7cm / 25.5"	145.5cm / 57.3"	2.2kg / 4.9lbs	25kg / 55lbs	86.4cm / 34"	Optional
3884-3 Two-stage Carbon Fibre EFP	52cm / 20.5"	157.1cm / 61.9"	5.5kg / 12.1lbs	45kg / 99lbs	76cm / 29.9"	Optional
150 mm Bowl Pozi-Loc Tripods						
3881-3 Two-stage Carbon Fibre EFP	52cm / 20.5"	157.1cm / 61.9"	5.5kg / 12.1lbs	45kg / 99lbs	76cm / 29.9"	Optional
V4086-001 Two-stage Aluminium EFP	52cm / 20.5"	157.1cm / 61.9"	6.2kg / 13.6lbs	55kg / 121lbs	76cm / 29.9"	Optional
Baby Leg Pozi-Loc Tripods						
3779-3 75mm Two-stage Aluminium ENG	23.7cm / 9.3"	51cm / 20.1"	2.1kg / 4.6lbs	25kg / 55lbs	32.7cm / 12.9"	N/A
3778-3 100mm Two-stage Aluminium ENG	23.7cm / 9.3"	51cm / 20.1"	2.1kg / 4.6lbs	25kg / 55lbs	32.7cm / 12.9"	N/A
3882-3 150mm Two-stage Aluminium EFP	28cm / 11"	50cm / 19.7"	4kg / 8.8lbs	45kg / 99lbs	36.3cm / 14.3"	N/A

Heavy Duty Tripods

Vinten's Heavy Duty Tripods provide **maximum control** and **dependability** wherever the next location may be.



Above: Uncompromising control with long lenses



Above: Adaptable to your requirements



HDT-1 and HDT-2

Offering the most extensive height range available from heavy duty tripods, the HDT-1 single-stage and HDT-2 two-stage models also feature increased torsional **rigidity** and **robustness** – ideal for large camera and lens combinations in any studio or OB application.

The pinned and glued telescopic leg design provides a wide range of height adjustment whilst offering **superior strength and reliability**. Set-up has been made even simpler with the addition of engraved leg markings and an integral level bubble for rapid, even deployment. In addition the clamping system provides progressive feel to a positive stop which indicates when the leg is locked, ensuring simple and confident clamping.





Whatever the terrain, the HDT's three position swivel foot ensures a stable base. Choose from an increased length spike for soft surfaces, self-levelling pad for harder surfaces or a socket to fit all Vinten skids and floor spreaders. The mid-level spreader is supplied as standard and ensures that the HDT is a convenient and stable option for any application. The single piece, fixed length design of the spreader offers exceptional



strength and robustness, and is simple to use and remove when necessary.

The HDT systems take care of even the smallest details; captive bolts ensure that set up is never disrupted and an integral carry handle provides comfortable and easy transport. Combined with the Vision 250 or Vector range, these systems provide maximum control and adaptability wherever the next location may be.

HDT (Heavy Duty Tripod)

Specification	HDT-1 Single-Stage Tripod	HDT-2 Two-Stage Tripod
Part No	3901-3	3902-3
 System Height Range	59 to 123cm / 23.2 to 48.4"	51.1 to 146cm / 20.1 to 57.5"
 Transport Length	78cm / 30.7"	73cm / 28.7"
 Weight	13.9kg / 30.6lbs	15.6kg / 34.4lbs
 Maximum Capacity	140kg / 308.6lbs	120kg / 264.5lbs

Elevation Unit



For use with the HDT-1 tripod, the elevation unit gives a unit stroke of 46cm / 18" for quick height range adjustment.

Specification Part No: 3370-3

Stroke:	46cm / 18"
Weight:	5kg / 11lbs
Maximum Capacity:	113kg / 249.2lbs

Floor Spreaders

Vinten floor spreaders offer maximum stability on flat ground. All floor spreaders feature telescopic legs ensuring a **generous** height range and are available for all Pozi-Loc and Heavy Duty tripods.



Vinten spreaders provide **stability** and camera control in **any situation**.

Specification:

Part No: 3363-3
Black lightweight floor spreader

 0.7kg / 1.5lbs

Part No: 3367-3
Heavy duty flexible floor spreader

 1.1kg / 2.4lbs

Part No: 3379-3
Baby legs spreader

 0.5kg / 1.1lbs

Spread-Loc Mid-Level Spreader

When the terrain is rough or uneven a mid-level spreader becomes the **safest** option to ensure stability and camera control in any situation.

The Spread-Loc mid-level spreader ensures fast and simple set-up and infinitely adjustable positioning in all applications. Its revolutionary design incorporates a unique deployment system and a number of innovative safety features to prevent accidental damage to both spreader and tripod. The Spread-Loc easily achieves multi-level positioning or an incredibly small footprint so in the toughest terrain or the tightest of spaces you can be sure of reliable camera support that gives great control.

Specification:

Part No: 3781-3
Spread-Loc and carpet feet

 1.3kg / 2.2lbs

Extended Arm

Radius: 500mm / 19.7"
Closed Length: 377mm / 25.5"
Tripod Footprint: Infinitely variable to maximum arm extension
Compatibility: Pozi-Loc tripods [excluding baby legs]

How it works...

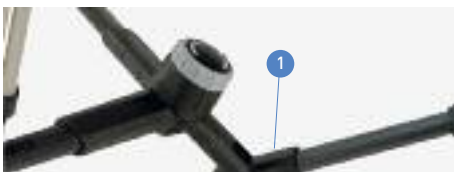

1. One of the Spread-Loc arms incorporates a dislocation feature, ensuring that the spreader will survive excess force.



2. Controlled by a central lock knob, the Spread-Loc arms are geared to move together. A single turn controls all three legs for fast repositioning. A unique ratchet mechanism provides an audible warning that the spreader is locked, but still allows the system to be closed for rapid repositioning.

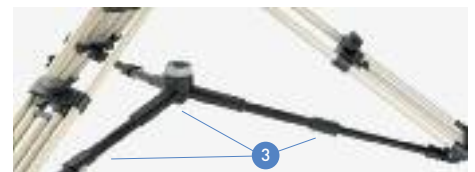

3. Individually extendable arms mean that Spread-Loc achieves maximum stability in the most unusual or restricted spaces.

Skids/Dollies

Designed to be lightweight and **compact** Vinten dollies fold and include an integral carry handle for easy transportation.

Vinten provides a range of dollies with varying capacities and each model is available in both Studio and OB configurations. All have fast action foot operated brakes and in addition the ENG and Heavy Duty Studio dollies are fitted with track locks to allow the use of tricycle steer mode.



This **lightweight** and compact **folding dolly** is supplied with individual wheel locks and removable cable guards and is ideal for studio and outside productions.



Specification:

Part No: PD114 Dolly

Type No: U005-103
 Capacity: 40kg / 88.2lbs
 Weight: 5.2kg / 11.5lbs
 Base Diameter: 112cm / 44.1"
 Wheel Diameter: 12.5cm / 5"

Reference Chart

Specification	ENG (Studio) V3955-0001	ENG (OB) V3955-0002	ENG (Small) V3955-0003	EFP (OB) 3497-3E	EFP (Studio) 3497-3G	HD (OB) 3497-3B	HD (Small) 3497-3C
Leg Radius	50cm / 19.7"	50cm / 19.7"	45cm / 17.7"	52.5cm / 20.7"	52.5cm / 20.7"	50cm / 19.7"	50cm / 19.7"
Castor Diameter	10cm / 3.9"	12.5cm / 4.9"	12.5cm / 4.9"	12.5cm / 4.9"	12.5cm / 4.9"	15cm / 6"	12.5cm / 4.9"
Skid Weight	5.8kg / 12.8lbs	6kg / 13.2lbs	5.9kg / 13lbs	7.7kg / 17lbs	9.1kg / 20lbs	8.8kg / 19.4lbs	9.3kg / 20.5lbs
Cable Guards	YES	NO	NO	NO	YES	NO	YES
Track Locks	YES	NO	NO	NO	NO	NO	YES
Capacity	50kg / 110.3lbs	40kg / 88.2lbs	50kg / 110.3lbs	100kg / 221lbs	100kg / 221lbs	160kg / 352.8lbs	160kg / 352.8lbs
Brakes	YES	YES	YES	YES	YES	YES	YES

Tracking Dolly/Skid

Very **robust** and **simple** to set. The Tracking Dolly is designed to offer the complete range of Osprey pedestals and HD Tripods the ability to operate on track.

Compatible with Osprey Elite (and earlier Osprey Pedestals) and Osprey light (with V3950-1110 adaptor)

Specification:

Part No: 3369-57

Weight: 11kg / 24.3lbs
 Capacity: 160kg / 353lbs
 Transport Size: 36cm x 23cm x 64cm / 14" x 9" x 26"
 Track Gauge: 62cm / 24.4"
 Wheels: 6.2cm quad wheels



Studio/OB Pan and Tilt Heads

"I have not seen another piece of equipment perform as **flawlessly** as the Vinten Vectors."

Paul Maibaum, ASC
Director of Photography



Vinten's Thin Film (TF) Drag Technology

Vinten patented TF drag system is designed to offer **complete control** at any level of movement, allowing you to concentrate on achieving the best possible filming. The high levels of control allow you to work without compromise delivering **smooth movement** in any situation.

TF drag

Vinten's TF (thin film drag) is a true fluid drag in the purest terms. Utilising the unique properties of a proprietary fluid TF drag provides smooth predictable resistance over a wide variety of levels and temperatures.

TF drags are constructed of multiple rotating plates alternating with static plates surrounded in the fluid which is vacuum filled to eliminate all air from the drag. The plates do not contact each other but are separated only by a thin film of the special fluid. When the head is moved the rotating plates move relative to the static plates creating a velocity profile shearing the fluid leading to drag (fig 1.0).

of the plates is equal to the fluid drag at this speed but does not increase as motion speed increases. This results in a smooth transition to almost constant drag force regardless of velocity (above the threshold) and the perfect whip pan.

- **Continuous, infinite drag adjustment control** allows you work without compromise delivering smooth movement in any situation
- **An extensive range of drag** from exceptionally light to exceptionally heavy allowing the camera to work in tune with you
- **A wide operating temperature** range from -40°C to $+60^{\circ}\text{C}$ means you can use the pan and tilt heads in a wide range of environments with uncompromising performance guaranteed
- **Outstanding** whip pan control

Fig 1.0

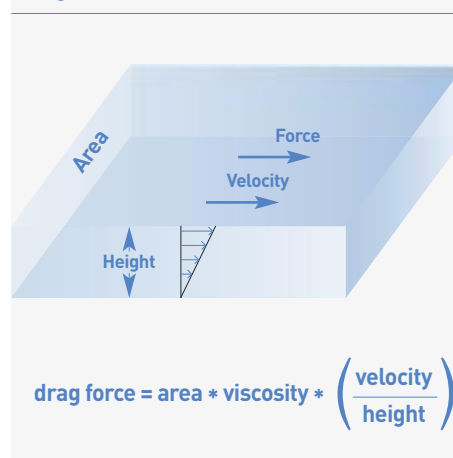

Drag level is infinitely adjustable by varying the area of overlap between the static and rotating plates.

At low to moderate speeds the fluid is in laminar flow and the separation of the plates (h) is constant yielding an evenly increasing level of drag with fluid velocity (u). As the pan (or tilt) motion speed crosses into the "whip pan" region the flow of fluid between the static and moving plates becomes sufficiently fast for the Bernoulli Effect to reduce the fluid pressure between the plates drawing them together the coefficient of lubricated friction

Fig 1.1

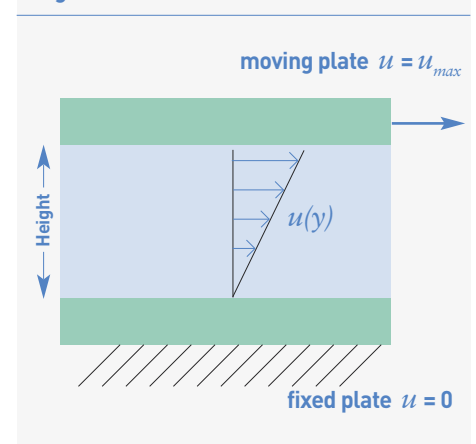

As soon as the motion speed is reduced below the level required for the plates to be deflected the fluid returns to the void between the plates and normal fluid drag is restored.

Vector 430 & 430S



The Vector 430 head offers a single choice when previously two heads were required.

Balance Chart

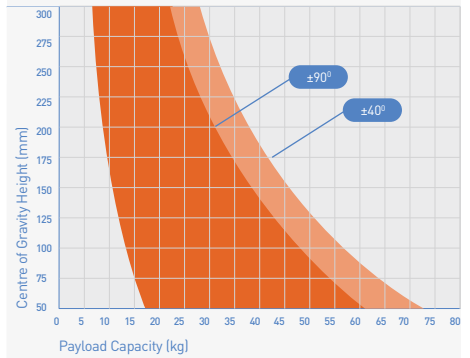

Above: The Vector 430/430S offers $\pm 90^\circ$ tilt across a wide payload range.

Specification:

Vector 430 Part No: V4006-0001
Vector 430S Part No: V4006-0002

- 22.7cm / 8.9"
- 20.6cm / 8.1"
- 28.5cm / 11.2" without pan bar
- 12.1kg / 26.7lbs
*including wedge adaptor & pan bar
- 10 to 43kg / 22 to 94.8lbs

Tilt Range:

- @ 37kg / 81.6lbs: $\pm 90^\circ$
- @ 43kg / 94.8lbs: $\pm 40^\circ$

Platform Adjustment: +5.5 to -10.6cm / +2.2 to -4.2"

Pan Bar: Single telescopic

Camera Fixing: EFP Quickfit Automatic Adaptor [3761-3]

Levelling Bubble: Illuminated

Drag Knobs: Backlit and calibrated

Counterbalance: Fully variable with digital readout

Colour: Black

Specification V4006-0001

Base fixing: 4 bolt flat with Quickfix groove

Specification V4006-0002

Base fixing: 150 mm ball base

Vector 430/430S designed to **Perfectly balanced** applications that use both the compact box lens and large EFP barrel lenses.

This unique design has enabled Perfect Balance to be incorporated into a previously unattainable **compact and lightweight** package whilst providing an **extremely large capacity range** of 10 to 43kg / 22 to 94.8lbs. This means that the Vector 430/430S offers a single choice when previously two heads were required.

Simple to rig and convenient to transport, the compact design of the Vector 430/430S maintains the functionality associated with Vinten's renowned Vector heads, including infinitely adjustable Perfect Balance and smooth TF drag technology.

Ergonomically designed controls, including a retractable counterbalance adjuster, backlit drag knobs and illuminated LCD display, ensure ease of use in any situation, while the base of the Vector 430 includes an integral Quickfix groove for fast and secure attachment. These features combined with a Quickfit wedge adaptor make the Vector 430 the perfect choice for busy multi-camera productions.

Watch the video:
4 steps to setting up Perfect Balance



Vector 75



Vector 75 combines the original Vector 70 LF fluid drag system, with operational enhancements from the **class-leading** Vector 750. The design retains that familiar Vector feel, without compromising any aspect of camera control.

Incorporated in the Vector 75 is a range of features which address the pressures of today's fast paced and cost conscious production company. This includes smooth operation in both pan and tilt movements with infinite adjustability for both the Perfect Balance and LF drag system. This ensures high levels of control and **exceptionally smooth movement** in any situation.

The Vector 75 features a centre of gravity range of 8 to 25cm / 3.1 to 9.8" and a maximum payload capacity of 75kg / 165.3lbs ensuring a wide range of camera and accessory combinations can be accommodated.

Like the Vector 750, the Vector 75 employs a unique counterbalance mechanism that does not use springs or cams. Instead a system of mechanical linkages balances cameras with various centre of gravity points, making adjustment simple and eliminating the need for time-consuming cam changes when altering the camera configuration.

Functionality and **durability** incorporated into one versatile product.



Above: High contrast blue LED level bubble illumination

Specification:

Part No: V4095-0001

- ⊕ 25.5cm / 10"
- ⊖ 35.5cm / 14"
- ⊖ 35cm / 13.5" without pan bar
- ⊕ 18.6kg / 41lbs
*including wedge adaptor & pan bar
- ⊕ 75kg / 165.3lbs

Tilt Range:	±52°
@ 75 kg / 165.3 lbs:	
Platform Adjustment:	33 cm / 13 "
Pan Bar:	Single telescopic
Camera Fixing**:	Wedge adaptor
Levelling Bubble:	Illuminated
Base fixing:	4 bolt flat with Quickfix groove
Colour:	Black

** Wedge plates not included
Standard wedge part no: 3053-3: (page 50)

Vector 750



Functionality and **durability** incorporated into one versatile product.

Below: 75kg maximum payload



Building on the legacy of the **legendary** Vector 700, the Vector 750 offers enhanced durability and increased payload.

Like the acclaimed Vector 700, the Vector 750 uses a unique counterbalance mechanism that does not use springs or cams. Instead a system of mechanical linkages balances cameras with various centre of gravity points, making adjustment simple and eliminating the need for time-consuming cam changes when altering the camera configuration.

The Vector 750 features a centre of gravity range span of 8 to 25cm / 3.1 to 9.8". This covers the full centre of gravity of both the Vector 700 models, creating a **broad range** of product capability and making product selection much easier. In addition the Vector 750 has a maximum payload of 75kg / 165.3lbs, allowing a greater use of camera accessories such as talent monitors and spotlights. A monitor bracket is available as an optional accessory. The inclusion of some additional robust internal components makes the Vector 750 even more **durable**.

The Vector 750 retains all of the excellent, proven operational features of the Vector 700 including smooth operation in both pan and tilt movements with infinite adjustability for both the Perfect Balance and TF drag system. This ensures high levels of control and exceptionally smooth movement in any situation.

Specification:

Part No: V4034-0001

- ⊕ 25.5cm / 10"
- ⊖ 35.5cm / 14"
- ⊙ 35cm / 13.5" without pan bar
- ⊕ 19.2kg / 42.3lbs
*including wedge adaptor & pan bar
- ⊕ 75kg / 165.3lbs

Tilt Range:
@ 75kg / 165.3lbs: ±52°
Platform Adjustment: 33cm / 13"
Pan Bar: Single telescopic
Camera Fixing**: Wedge adaptor
Levelling Bubble: Illuminated
Base fixing: 4 bolt flat with Quickfix groove
Colour: Black

** Wedge plates not included
Standard wedge part no: 3053-3 (page 50)

Vector 950



The **compact** and durable Vector 950 head uses TF drag for **enhanced control**.

Balance Chart

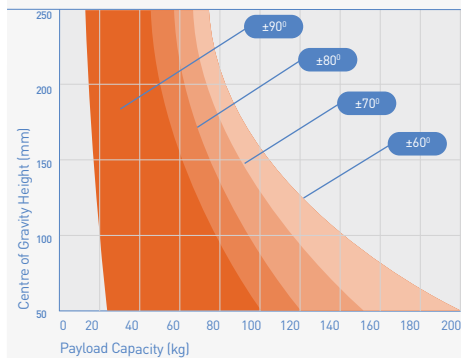

The Vector 950 capacity is **up to 120kg** and at this payload provides $\pm 60^\circ$ of perfectly balanced tilt, allowing the safe control of today's long OB lenses and large 3D rigs.

The Vector 950 features TF Drag, allowing outstanding whip pan control and an extensive operational temperature range from -40°C through to $+60^\circ\text{C}$. The high output tilt drag modules also provide superb holding force and enhanced control in windy conditions. Combining these characteristics with infinite Perfect Balance adjustment ensures that the effort needed to control the effect of a heavy, moving camera payload remains **constant** and **predictable**, eliminating a major distraction during filming.



The compact and durable Vector 950 head incorporates a wealth of features. Set-up is aided through the inclusion of a tilt deadlock, Quickfix groove in the base, retractable carry handle and illuminated controls, as well as an LCD display that offers a counterbalance readout that can be set for known payloads. The pan and tilt brakes are positioned at the rear of the head, making them easily accessible, and the camera plate can be simply adjusted forward and back using a retractable, ergonomically designed adjuster.

Specification:

Part No: V3996-001

- 24.8cm / 9.8"
- 22.5cm / 8.9"
- 34.2cm / 13.5" without pan bar
- 16.6kg / 36.6lbs
*including wedge adaptor & pan bar
- 16 to 120kg / 35.3 to 264.5lbs

Tilt Range:

@ 60kg / 132.3lbs: $\pm 90^\circ$

@ 120kg / 264.5lbs: $\pm 60^\circ$

Platform Adjustment: +5.5 to -12.5cm / +2.2 to -4.9"

- Pan Bar: Single telescopic
- Camera Fixing**: Wedge adaptor
- Levelling Bubble: Illuminated
- Drag Knobs: Backlit and calibrated
- Counterbalance: Fully variable with digital readout
- Base fixing: 4 bolt flat with Quickfix groove
- Colour: Black

** Wedge plates not included Standard wedge part no: 3053-3 (page 50)

Studio/OB Pedestals



The Vinten range of pedestals suit a wide variety of applications and budgets, and will provide **superior camera control** and freedom of movement in any situation.



Above: Precise tracking



Above: Intuitive to use

“I’ve always found that my **operators prefer Vinten** because of the precise tracking of the pedestal in the four-camera environment. It’s more than the durability and lack of down time. Often, the outside guys have to turn, pull, lift, pan and tilt in moments because they have to get back to position quickly. The fluidness and ease to reset is very important and that’s one of the things that Vinten has always excelled in over the years.”

Donald A. Morgan, ASC

Vision pedestals pay attention to every detail. The ergonomic designs are quiet and strong, providing optimum support whilst keeping noise levels to a minimum.

All of the pedestals feature a perfectly balanced pedestal column that enables precise camera elevation: allowing the operator to avoid the effort and extra concentration needed to control an unbalanced camera and pay full attention to shot framing.

Free warranty extension

Every Vinten is backed by service centres across the world. Register, free, for an extended warranty at www.vinten.com/en/servicing-warranty

Service and maintenance

Our service team’s focus is to keep your Vinten in the best condition beyond the initial warranty. Backed by regular training, our engineers can provide additional assurance of Vinten’s quality with their preventative maintenance service.

Holding 1,000’s of different spare parts and replacement units, our service centres worldwide are designed to continue to support your Vinten well beyond the warranty. Whether you require preventative maintenance, a refurbish, or help installing replacement parts, our global service team can quickly troubleshoot and then fix your problem.



www.vinten.com/en/servicing-warranty

Perfect Balance provides effortless fingertip control and reduces operator fatigue.



www.vinten.com/en/vinten-tv

Key to Symbols:

- 🏠 Height
- 🚚 Transport Length
- 📏 Length
- ⚖️ Weight
- 📏 Width
- 👤 Capacity Range

Vision Ped Plus

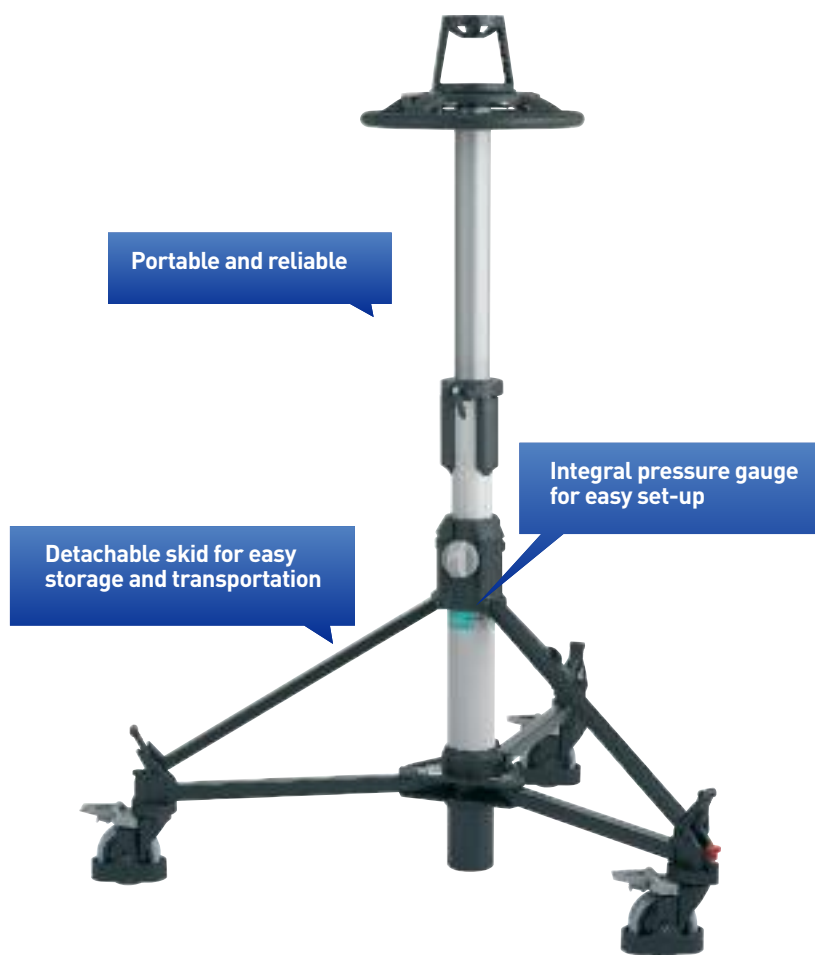

The Vision Ped Plus is ideal for applications where **simplicity** of operation, **portability** and **reliability** are key requirements.



The Vision Ped Plus is ideal where simplicity of operation, portability and reliability are key. The pedestal has an integral manual pump as well as an inlet valve for use with an external supply. A pressure gauge enables **clear** and **reliable set-up** while the detachable skid allows the pedestal to be simply broken down into two sections for **easy storage** and transportation.

With a maximum payload of 30kg / 66lbs, a height range of 75cm to 160cm / 29.5 to 63" and an on-shot stroke of 41cm / 16.1", the Vision Ped Plus is a highly functional and competitive pedestal; the perfect solution for situations where professional framing and creative movement is essential.

Specification:

Part No: V3951-0001

[Complete with 100 mm bowl adaptor]

-  30kg / 66lbs
-  75 to 160cm / 29.5 to 63"
-  13.7kg / 30.2lbs

On-Shot Stroke:	41cm / 16.1"
Tracking Width:	69cm / 27"
Transit Width:	73cm / 28.7"
Wheel Diameter:	10cm / 4"
Steering Ring Diameter:	38cm / 15"
Wheel Lock:	Yes
Ground Clearance:	1.4cm / 0.6"
Colour:	Black

Pro-Ped Pedestal





The Pro-Ped **lightweight** pedestal is stable and robust, the lower stage of the two-stage system is **balance assisted** to give simple elevation whilst the upper stage provides Perfect Balance and **on-shot** movement. A built in pump makes counterbalance simple.

For studio use the dolly base is supplied with 12.5cm / 5" wheels with track locks and cable guards. The OB version has 15cm / 6" wheels, providing greater ground clearance.

Perfect Balance and on-shot movement for payloads up to 55kg / 121lbs.

Specification:



Part No: V3983-3C Studio

-  55kg / 121lbs
[max. capacity includes trim weights]
-  66.6 to 148.5cm / 26.2 to 58.4"
-  28.5kg / 62.8lbs

On-Shot Stroke:	41cm / 16.1"
Tracking Width:	95cm / 37.4"
Transit Width:	86cm / 33.8"
Wheel Diameter:	12.5cm / 5"
Steering Ring Diameter:	53.4cm / 20.8"
Wheel Lock:	Yes
Trim Weights:	3.5kg / 7.5lbs
Ground Clearance:	1.9cm / 0.75"
Colour:	Black

Specification:

Part No: V3983-3B OB

-  55kg / 121lbs
[max. capacity includes trim weights]
-  67.8 to 149.7cm / 26.7 to 58.9"
-  28kg / 61.7lbs

On-Shot Stroke:	41cm / 16.1"
Tracking Width:	95cm / 37.4"
Transit Width:	86cm / 33.8"
Wheel Diameter:	15cm / 6"
Steering Ring Diameter:	53.4cm / 20.8"
Wheel Lock:	Yes
Trim Weights:	3.5kg / 7.5lbs
Ground Clearance:	3.15cm / 1.2"
Colour:	Black

Osprey Light



The Osprey Light is ideal for studios that require a **lightweight** pedestal which does not compromise functionality.

The Osprey Light is designed for the growing number of small studios that require the **quality** of on shot movement synonymous with Vinten pedestals.



Perfect Balance is easy to achieve in any situation as the Osprey Light has an integral manual pump as well as an inlet valve for use with external pressure sources.

The Osprey Light is ideal for studios that require a lightweight pedestal which does not compromise functionality.

The Osprey Light is a 40kg / 88.2lbs capacity pedestal, with crabbing base capability. This single stage pedestal also has an on-shot stroke of 54cm / 21.2" and a significantly improved wheel braking mechanism that eliminates the flat spots that can ruin a rolling shot.

Specification:

Part No: V3950-0001

-  40kg / 88lbs
[max. capacity includes trim weights]
-  76.5 to 130.5cm / 30.1 to 51.4"
-  21.8kg / 48.1lbs

On-Shot Stroke:	54cm / 21.2"
Wheel Lock:	Yes
Tracking Width:	80.6cm / 31.7"
Transit Width:	70cm / 27.5"
Wheel Diameter:	10cm / 4"
Steering Ring Diameter:	50cm / 19.7"
Trim Weights:	2.4kg / 5.3lbs
Ground Clearance:	1cm / 0.4"
Colour:	Black



Osprey Elite



Designed to **support** the latest range of digital, portable and full facility cameras for both studio and OB productions.

Specification:



Part No: 3574-3C Studio

-  75kg / 165lbs
[maximum capacity includes trim weights]
-  66 to 143cm / 26 to 56"
-  45.7kg / 101lbs

On-Shot Stroke:	77cm / 30.3"
Wheel Lock:	Yes
Tracking Width:	97cm / 38.2"
Transit Width:	80cm / 31.5"
Narrow Transit Width:	72.3cm / 28.5"
Wheel Diameter:	12.5cm / 5"
Detachable Steering	
Ring Diameter:	53.3cm / 21"
Trim Weights:	3.5kg / 7.7lbs
Ground Clearance:	2cm / 0.8"
Colour:	Black

Specification:

Part No: 3574-3B OB

-  75kg / 165lbs
[maximum capacity includes trim weights]
-  68.5 to 145.5cm / 27 to 57.3"
-  48.7kg / 107.4lbs

On-Shot Stroke:	77cm / 30.3"
Wheel Lock:	Yes
Tracking Width:	97cm / 38.2"
Transit Width:	80cm / 31.5"
Narrow Transit Width:	72.3cm / 28.5"
Wheel Diameter:	16cm / 6.3"
Detachable Steering	
Ring Diameter:	53.3cm / 21"
Trim Weights:	3.5kg / 7.7lbs
Ground Clearance:	3.45cm / 1.2"
Colour:	Black

The Osprey Elite is extremely **versatile**, designed to support a wide range of portable and full facility cameras for both studio and OB productions. The two-stage column offers **on-shot** movement from a minimum height of 66cm / 26" to a maximum height of 143cm / 56", and features full **crab and steer facilities** controlled from a central steering ring.

The studio version of the Osprey Elite includes cable guards, whilst the larger wheels of the OB version offer greater ground clearance. Both versions have an exceptional combination of lightness and structural integrity giving maximum stability whilst still allowing the column and dolly base to fold for easy transportation.

The Osprey Elite is also ideal for use on track when combined with Vinten's Tracking Skid (see page 25). Other optional accessories include a portable hand pump to counterbalance the pneumatic system, a large steering ring and OB wheel cable guards (see page 51).





Quartz One and Two



Precise crab and steer control from a **central steering** ring, together with the ability to accelerate smoothly and rapidly; enables **easy repositioning**.

Specification:



Part No: 3825-3 Quartz One

-  95kg / 209.5lbs
[max. capacity includes trim weights]
-  71 to 122cm / 28 to 48"
-  89.5kg / 197.3lbs

On-Shot Stroke:	51cm / 20"
Tracking Width:	108cm / 42"
Transit Width:	80cm / 31.5"
Wheel Diameter:	12.5cm / 5"
Detachable Steering Ring Diameter:	63.5cm / 25"
Trim Weights:	3.5kg / 7.7lbs
Ground Clearance:	2cm / 0.8"
Colour:	Black

Specification:

Part No: 3826-3 Quartz Two

-  80kg / 176.4lbs
[max. capacity includes trim weights]
-  66 to 143cm / 26 to 56"
-  88.9kg / 187.4lbs

On-Shot Stroke:	77cm / 30.3"
Tracking Width:	108cm / 42"
Transit Width:	80cm / 31.5"
Wheel Diameter:	12.5cm / 5"
Detachable Steering Ring Diameter:	63.5cm / 25"
Trim Weights:	3.5kg / 7.7lbs
Ground Clearance:	2cm / 0.8"
Colour:	Black

Vinten's Quartz pedestals can accommodate a **wide range** of camera, lens and teleprompter **combinations** and are particularly suitable for studio productions.

The Quartz One is a single-stage pedestal with a maximum capacity of 95kg / 209.5lbs. The Quartz Two provides greater operational flexibility with its two-stage column and 77cm / 30.3" on-shot stroke whilst supporting up to 80kg / 176.4lbs of payload.

The Quartz design offers precise crab and steer control from a central steering ring, together with the ability to accelerate smoothly and rapidly; enabling easy repositioning even in the tightest of sets. The design of the base offers maximum stability, a single foot brake gives extra control at all times, and the fully skirted base incorporates a cable guard system that is simply adjusted by three external knobs.



Quattro-L and Quattro-OBL



A revolutionary pneumatic design ensures that the Quattro pedestals provide **Perfect Balance** throughout their four-stages of **elevation**.

Specification:

Part No: V3852-0003 Quattro-L

-  105kg / 231.5lbs
[max. capacity includes trim weights]
-  46.2 to 149cm / 18.2 to 58.7"
-  158kg / 348.4lbs

On-Shot Stroke:	100cm / 39.4"
Tracking Width:	107cm / 42.1"
Transit Width:	92.4cm / 36.4"
Wheel Diameter:	16cm / 6.3"
Detachable Steering	
Ring Diameter:	74cm / 29"
Trim Weights:	7.5kg / 16.5lbs
Ground Clearance:	2.8cm / 1.1"
Colour:	Black

Specification:

Part No: V4002-0002 Quattro-OBL

-  105kg / 231.5lbs
[max. capacity includes trim weights]
-  50.8 to 150.8cm / 20 to 59.4"
-  116kg / 255.8lbs

On-Shot Stroke:	100cm / 39.4"
Tracking Width:	98cm / 38.5"
Transit Width:	87cm / 34.2"
Wheel Diameter:	20cm / 7.8"
Detachable Steering	
Ring Diameter:	59cm / 23.2"
Trim Weights:	7.5kg / 16.5lbs
Ground Clearance:	5cm / 2"
Colour:	Black

The Quattro is **the original four-stage pedestal** and is available in both studio, OB, small base and encoded versions.

Both the Quattro-L studio pedestal and Quattro-OBL outside broadcast pedestal provide an extensive height range and the opportunity to achieve lower angle shots, as well as an impressive on-shot stroke of 100cm / 39.4".

A revolutionary pneumatic design ensures that the Quattro pedestals provide Perfect Balance throughout their four-stages of elevation, ensuring that they offer the exact support required for the camera operator to raise and lower the camera with minimal effort.

A unique Document Holder, designed to enhance the day-to-day use of the pedestals, is available as an optional accessory.

- **Perfect Balance provides fingertip control and reduces operator fatigue**
- **Quiet operation minimises set noise levels**
- **Excellent height range allows greater shot creativity**
- **Stylish ergonomic design offers easy access to controls**
- **Lower operating pressure allows a safer charging source to be used**



Quattro-SL



Compact construction improves portability between studios without compromising stability



Easily tracks through any 76.2 cm / 30" set restriction

Single point actuated cable guard adjustment

The Quattro-SL easily tracks through **confined** spaces and can work **in close proximity** to other pedestals.

Dimensions

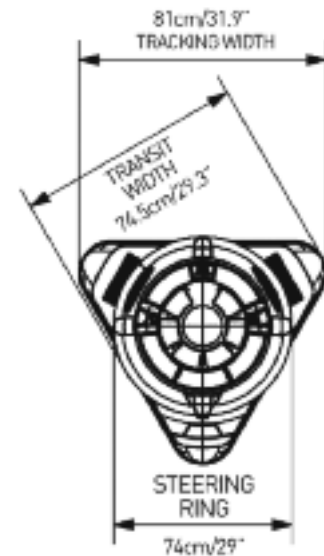

The Quattro-SL, a **compact** pedestal designed for multi-camera studio locations, is perfect for the increasing number of **restricted sets** and smaller studios around the world.

- **Perfect Balance** provides fingertip control and reduces operator fatigue
- **Quiet operation** minimises set noise levels
- **Excellent height range** allows greater shot creativity
- **Stylish ergonomic design** offers easy access to controls
- **Lower operating pressure** allows a safer charging source to be used

Incorporating most of the features of the larger Quattro pedestals, the Quattro-SL easily tracks through confined spaces and can work in close proximity to other pedestals. The cable guard can be easily adjusted from a single point actuator, reducing the need for the operator to move around the pedestal in cramped situations. The compact design and lightweight construction improves portability in and between studios without compromising stability or Perfect Balance.

Specification:

Part No: V3963-0002 Quattro-SL

- 80kg / 176.4lbs
[max. capacity includes trim weights]
- 47 to 147cm / 18.5 to 57.8"
- 136kg / 300.6lbs

On-Shot Stroke:	100cm / 39.4"
Tracking Width:	81cm / 31.9"
Transit Width:	74.5cm / 29.3" [with small steering ring] 82cm / 32.2" [with large steering ring]
Footprint:	80.6 x 74.5cm / 31.8 x 29.4"
Wheel Diameter:	12cm / 4.9"
Detachable Steering Ring Diameter:	74cm / 29"
Trim Weights:	7.5kg / 16.5lbs
Ground Clearance:	2cm / 0.8"
Colour:	Black

Virtual/Augmented Reality



Vector 430i

Precise, real time digital electronic positioning of pan and tilt





Small, lightweight and high capacity



The Vector 430i head is the **ideal** choice for EFP camera set-ups where **virtual reality** is required.

Specification:

Part No: V4089-0001

-  22.7cm / 8.9"
-  20.6cm / 8.1"
-  28.5cm / 11.2" without pan bar
-  12.6kg / 27.7lbs
*including wedge adaptor & pan bar
-  10 to 43kg / 22 to 94.8lbs

Tilt Range:	
@ 37kg / 81.6lbs:	±90°
@ 43kg / 94.8lbs:	±40°
Pan Resolution:	1.48 million counts per 360°
Tilt Resolution:	1.48 million counts per 360°
Encoder Power Requirements:	5 volts dc ± 10%
Platform Adjustment:	+5.5 to -10.6cm / +2.2 to -4.2"
Pan Bar:	Single telescopic
Camera Fixing:	EFP Quickfit Automatic Adaptor [3761-3]
Levelling Bubble:	Illuminated
Drag Knobs:	Backlit and calibrated
Counterbalance:	Fully variable with digital readout
Base fixing:	4 bolt flat with Quickfix groove
Colour:	Black

Vector 430i delivers **precise positional data** for virtual and augmented reality applications in outside broadcast and studio environments.

The pan and tilt head incorporates a new Intelligence Module allowing semi automatic set-up and slide plate tracking. When combined with the VRI box [see page 45] this provides precise real-time digital electronic positioning of pan and tilt to allow graphics to be placed perfectly into the live environment. The positional information is also displayed on a graphical user interface for ease of set up and calibration.

These features, combined with the functionality of the Vector 430 [see page 28], make the Vector 430i an ideal choice for EFP camera set-ups where virtual reality is required – now or in the future.

Vector 750i



Unique slide plate and balance mechanism position measurement for mid-broadcast camera adjustments

The market leading Vector 750 with virtual reality capability

Unprecedented positional accuracy for an encoded pantographic head

Vector 750i is **the first** encoded pantographic head from Vinten, providing the perfect solution **for virtual reality** in both studio and outside broadcast for operators who love the feel of the Vector 750.





The pan and tilt head incorporates a new Intelligence Module allowing semi automatic set-up, slide plate tracking and kinematic compensation. When the Vector 750i is combined with the VRI box [see page 45] these features provide the most precise positioning data possible from a pantographic head, to ensure stable and accurate placement of virtual graphics into the live environment.

The Vector 750i maintains all of the market leading functionality of the Vector 750 [see page 30], making this pan and tilt head an ideal choice for large camera combinations where virtual reality is required – now or in the future.

The Vector 750i provides the **perfect** solution for **virtual reality** in both studio and outside broadcast applications.

Specification:

Part No: V4080-0001

-  26.2cm / 10.3"
-  35.5cm / 14"
-  35cm / 13.5" without pan bar
-  19.7kg / 43.4lbs
*including wedge adaptor & pan bar
-  75kg / 165.3lbs

Tilt Range:	
@ 75kg / 165.3lbs:	±52°
Pan Resolution:	1.8 million counts per 360°
Tilt Resolution:	1.6 million counts per 360°
Encoder Power Requirements:	5 volts dc ± 10%
Platform Adjustment:	+5.5 to -12.5cm / +2.2 to -4.9"
Pan Bar:	Single telescopic
Camera Fixing**:	Wedge adaptor
Levelling Bubble:	Illuminated
Drag Knobs:	Backlit and calibrated
Counterbalance:	Fully variable with digital readout
Base fixing:	4 bolt flat with Quickfix groove
Colour:	Black

* VRI box, PDA and cables not supplied with the head [see page 45]

** Wedge plates not included Standard wedge part no: 3053-3

Vector 950i

Precise, real-time digital electronic positioning of pan and tilt

Large capacity range

Popular choice for users of 3D stereo assemblies



The Vector 950i is fast becoming the pan and tilt **head of choice** for users of 3D stereo camera assemblies.





Vector 950i offers virtual reality capability to the **award winning** Vector 950.

The Vector 950i is equipped with optical incremental encoders in both the pan and tilt axis, which are accessed via a connector at the front of the head. When connected to the VRI box [see page 45] the head can provide precise, real-time digital electronic positioning for any virtual or augmented reality production.

With a large capacity range and compact and durable design the Vector 950i provides a practical solution for outside broadcast and studio productions where virtual reality is required – now or in the future. Based on the Vector 950 (see page 31), the 950i is also fast becoming the pan and tilt head of choice for users of 3D stereo camera assemblies.

Specification:

Part No: V4056-0001

-  24.8cm / 9.8"
-  22.5cm / 8.9"
-  34.2cm / 13.5" without pan bar
-  17.2kg / 37.9lbs
*including wedge adaptor & pan bar
-  16 to 120kg / 35.3 to 264.5lbs

Tilt Range:	
@ 60kg / 132.3lbs:	±90°
@ 120kg / 264.5lbs:	±60°
Pan Resolution:	1.8 million counts per 360°
Tilt Resolution:	1.8 million counts per 360°
Encoder Power Requirements:	5 volts dc ± 10%
Platform Adjustment:	+5.5 to -12.5cm / +2.2 to -4.9"
Pan Bar:	Single telescopic
Camera Fixing**:	Wedge adaptor
Levelling Bubble:	Illuminated
Drag Knobs:	Backlit and calibrated
Counterbalance:	Fully variable with digital readout
Base fixing:	4 bolt flat with Quickfix groove
Colour:	Black

** Wedge plates not included Standard wedge part no: 3053-3

Virtual Reality Interface Box

The Virtual Reality Interface Box **links** the i-series pan and tilt heads **to any Graphics System.**



The VRI box **enables** the use of the Vector 430i, 750i and 950i pan and tilt heads in virtual reality applications. The box processes the positional data from the head encoders and also offers a **direct interface** to lenses with encoder outputs, (or bolt on lens encoders) to provide a **single data stream** to the graphics rendering system. Each VRI box is supplied with mounting brackets, GUI, and head interface cable.

Specification:

Part No: V4083-0001

Power In:	110-250v AC or 9-28v DC, power consumption 80 w
Power Out:	12v DC @ 1A / 24v DC @ 1A I/O: Genlock (1 in, 2 out) DeviceLink.i Lens encoders (Quadrature)
Tracking Data Output:	RS422 / RS232 Radamec D1 packet
Accessories:	Vinten Inclinator for perfect placement of OB graphics [V4083-0003] PDA based GUI (for set-up and control) [V4014-0003]

Quattro-SE



Full X Y Z tracking
with the usability
of a standard
Vinten pedestal.

The Quattro SE is a **manually operated** pedestal with built-in encoders, making it perfect for today's virtual studios.

Built on the Quattro, the SE maintains benefits of the Quattro range.

High quality precision encoders have been integrated into the wheels and column. The base processor delivers the accurate position data for all pedestal axes.

To simplify virtual tracking, the output from the pedestal is integrated with the Vector 430i, Vector 750i or Vector 950i head and lens position feedback into a single data channel to the rendering system of a virtual software image generator.

The combination of simple homing and set up procedures, precise digital electronic positioning and on shot performance ensure that the Quattro SE and i series head combination is an ideal solution for virtual studios around the world.

Specification:

Part No: V3851-0001

Dimms:	H 1498mm W 745mm
Weight:	136kg
Payload:	85kg
Resolution:	+/-<-1mm (X,Y,Z) +/-0.02deg (Orientation)

Vinten

RADAMEC
BROADCAST ROBOTICS

Driving the future...

For the next step in **Robotic camera control systems** take a look at what the Vinten Radamec range has to offer...



www.vintenradamec.com



 Vinten Radamec™
A Vitec Group brand

info@vintenradamec.com
www.vintenradamec.com

Adaptors and Accessories

	Non-telescopic Pan Bar and Clamp	Telescopic Pan Bar and Clamp	Extended Pan Bar Clamp	Camera Mounting Plate and Screws	Extended Camera Slide Plate complete with 2 x 3/8" screws	ENG Quickfit Automatic Adaptor with 3763-11 wedge	ENG Quickfit Wedge	EFP Quickfit Automatic Adaptor with 3761-13 wedge
Head Compatibility								
Vision blue/blue3/blue5	3219-110	3219-113		V4043-1901	3330-33	3471-3	3763-11	
Vision 8AS/10AS	3219-101	3219-91	3219-105	V4045-1901	3330-33	3471-3	3763-11	
Vision 100		3219-91	3219-105	3364-900SP	3330-33	3471-3	3763-11	
Vision 250		3219-91	3219-105	3364-900SP	3330-33	3471-3	3763-11	3761-3

	Rounded Soft Case	Square Soft Case	Hard Case	Tube	Pozi-Loc Carrying Strap	75mm ball to 100mm bowl adaptor	Quickfix adaptor with 100mm ball base 45kg / 99.2lbs max. capacity
Head Compatibility							
Vision blue/blue3/blue5 + two-stage tripod	3358-3	3340-3	3909-3	3396-3	3425-3P		
Vision blue/blue3/blue5 + single-stage tripod	3334-3		3908-3	3372-3	3425-3P		
Vision 8AS/10AS + single-stage tripod	3334-3		3908-3	3372-3	3425-3P		
Vision 100 + single-stage tripod				3372-3	3425-3P		
Vision 8AS/10AS + two-stage tripod	3358-3	3340-3	3909-3	3396-3	3425-3P		
Vision 100 + two-stage tripod		3340-3	3909-3	3396-3	3425-3P		
Vision 250 + EFP tripod		3341-3	3910-3	3411-3	3425-3P		
75 mm bowl Pozi-Loc					3425-3P		
100 mm bowl Pozi-Loc					3425-3P	3330-243	3144-3
150 mm bowl Pozi-Loc				3398-3	3425-3P		
Heavy Duty Tripod HDT-1		3535-3		3411-3S			
Heavy Duty Tripod HDT-2		3343-3		3411-3T			
ENG/EFP Skids		3440-202					
Heavy Duty Skids							

“Thank you for helping me keep your fine products in action!”

Spare parts store user

EFP Quickfit Wedge	Side Monitor Bracket	Ball base for Vision 250	Quickfix/4-bolt flat base for Vision 250	75 mm ball to 100mm bowl adaptor	Transit Case	blueBridge small camera adapter
--------------------	----------------------	--------------------------	--	----------------------------------	--------------	---------------------------------

						
				3330-243		V4106-1003
3761-13	3525-21	3525-900SP	3525-901SP		3397-3	

Visit the Vinten spare parts store:



<http://store.vinten.co.uk/>

Quickfix adaptor with 150mm ball base 45kg / 99.2lbs max. capacity	4-bolt to 150mm Bowl Adaptor	Quickfix adaptor with 4-bolt base	Quickfix Levelling Adaptor with 4-bolt flat base 45kg / 99.2lbs max. capacity	Heavy-Duty Quickfix Adaptor 100kg / 220.5lbs max. capacity	Mitchell Adaptor - 4-bolt flat base to Heavy-Duty Tripod	100mm Levelling Bowl Adaptor	150mm Levelling Bowl Adaptor	200mm Hi-Hat	Vinten 4-bolt Fixing to Skid
--	------------------------------	-----------------------------------	---	--	--	------------------------------	------------------------------	--------------	------------------------------

									
3143-3	3104-3								
		3100-3	3328-30	3490-3	3103-3	3330-16	3330-17	3155-3B*	
		3100-3	3328-30	3490-3	3103-3	3330-16	3330-17	3155-3B*	
									3368-24B*
									3368-24B*

Adaptors and Accessories continued

	Transit Case	Extra Short Pan Bar and Clamp	Short Pan Bar and Clamp	Telescopic Pan Bar and Clamp	Standard Wedge with Fixing Screws	Short Wedge with Fixing Screws	Intermediate Plate	EFP Quickfit Automatic Adaptor
Head Compatibility								
Vector 430S			3219-116	3219-115			3384-11	3761-3
Vector 430/430i			3219-116	3219-115			3384-11	3761-3
Vector 950/950i	3907-3	3219-93	3219-94	3219-82	3053-3	3391-3	3384-11	
Vector 75/750/750i	3355-3	3219-93	3219-94	3219-82	3053-3	3391-3	3384-11	
	Large steering ring	Small steering ring	Document holder for Quattro pedestals (exc. Quattro-SL)	Osprey Light to Tracking Skid Adaptor [for use with 3369-57]	Quickfix adaptor with 4-bolt base 45kg / 99.2lbs max. capacity	Quickfix Levelling Adaptor with 4-bolt flat base 45kg / 99.2lbs max. capacity	Heavy-Duty Quickfix Adaptor 100kg / 220.5lbs max. capacity	Mitchell Spider Adaptor
Head Compatibility								
Vision Ped Plus					3100-3	3328-30	3490-3	3055-3B*
Pro-Ped					3100-3	3328-30	3490-3	3055-3B*
Osprey Light				V3950-1110	3100-3	3328-30	3490-3	3055-3B*
Osprey Elite	3429-21	3374-17			3100-3	3328-30	3490-3	3055-3B*
Quartz One and Two	3429-21**	3374-17			3100-3	3328-30	3490-3	3055-3B*
Quattro-L	3445-43**	3445-42	3384-12		3100-3	3328-30	3490-3	3055-3B*
Quattro-OBL	3445-43	3445-42**	3384-12		3100-3	3328-30	3490-3	3055-3B*
Quattro-SL	3445-43**	3445-42			3100-3	3328-30	3490-3	3055-3B*

Vinten supply a range of accessories and adaptors to help improve the versatility, portability and day-to-day usability of Vinten products.

Key to code:
 * Code for black version
 ** Fitted as standard on product

Service

Vinten equipment is renowned for its quality and reliability. Visit the Vinten spare parts store. Our focus is to keep supporting you. In the unlikely event that a problem should occur Vinten customers are supported by a wide service network. Vinten has service centres in six locations that span the world and every authorised dealer is able to carry out repairs and exchange parts: there is always someone available to help.

To contact your local service team please visit www.vinten.com/find-service-centre

Guarantee

All Vinten equipment is supplied with a one year guarantee and this can be easily extended to two years by registering online at www.vinten.com.

Extend your warranty:



www.vinten.com/en/my-vinten

EFP Quickfit Wedge	Side Monitor Bracket	Mitchell Centre Screw	Scaffold Clamp	Mitchell Base with Wingnut
--------------------	----------------------	-----------------------	----------------	----------------------------



3761-13				
3761-13		3724-3	3407-1A	3750-3
	3803-27	3724-3	3407-1A	3750-3
	V4034-1010	3724-3	3407-1A	3750-3

100mm Levelling Bowl Adaptor	150mm Levelling Bowl Adaptor	200mm Hi-Hat	Portable manual pump for pedestals	Nitrogen Charging Adaptor	OB wheel set for Osprey Elite (3)	OB wheel cable guards for Osprey Elite (3)	Set of soft wheels for Quartz One and Two	Studio wheel set for Quattro-OB and OBL (inc. cable guards)	Tiller bar for Osprey
------------------------------	------------------------------	--------------	------------------------------------	---------------------------	-----------------------------------	--	---	---	-----------------------



3330-16**			3357-21	3702-32					
3330-16	3330-17	3155-3B	3357-21	3702-32					
3330-16	3330-17	3155-3B	3357-21	3702-32					
3330-16	3330-17	3155-3B	3357-21	3702-32	3329-30	3329-44			3329-21
3330-16	3330-17	3155-3B	3357-21	3702-32			3429-904SP		
3330-16	3330-17	3155-3B	3357-21	3702-32				3446-910SP	
3330-16	3330-17	3155-3B	3357-21	3702-32					

Quickfix®

The **time** taken for set-up and breakdown **is wasteful**, which is why Vinten have developed their range of Quickfix adaptors. Constructed entirely from corrosion resistant components, **Quickfix** adaptors are **ideal** for OB applications.

1. A simple lever operation secures and releases the pan and tilt head in seconds, leaving more time to capture the action.
2. The Quickfix profile is incorporated into the base of current pan and tilt heads. (Screw on ring adaptor available for older heads).
3. The locking system will not release the head until the safety catch is opened.

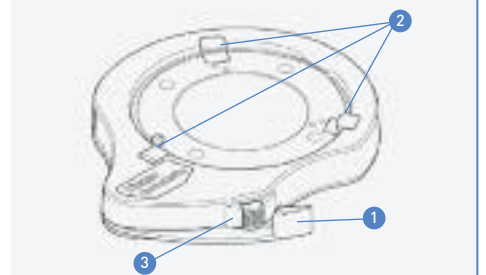

System Guides

Recommended guide only

Please refer to individual specifications for the maximum weight-carrying capacity of each product. To match your camera and accessories visit our website www.vinten.com/en/what-camera-which-head

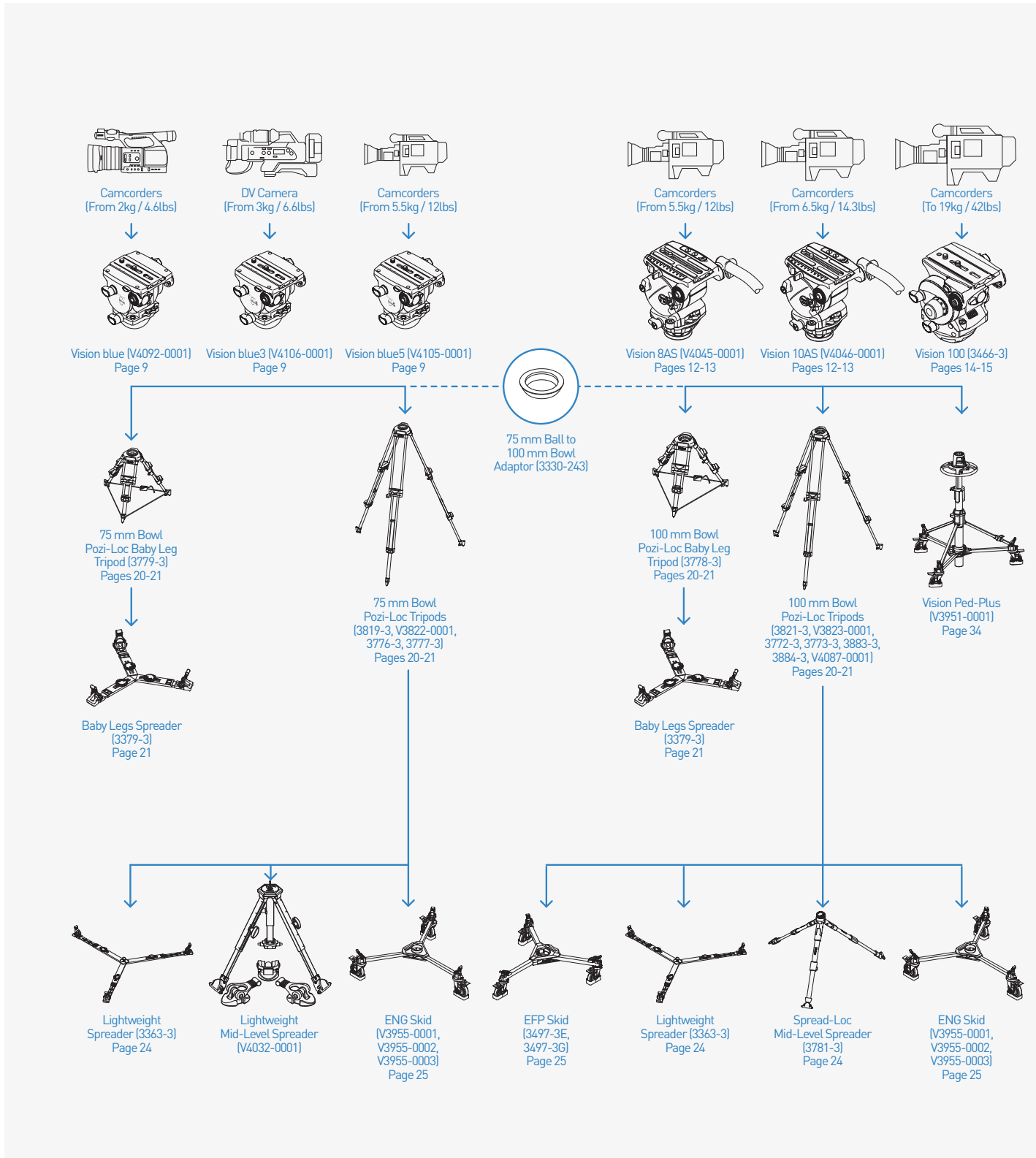

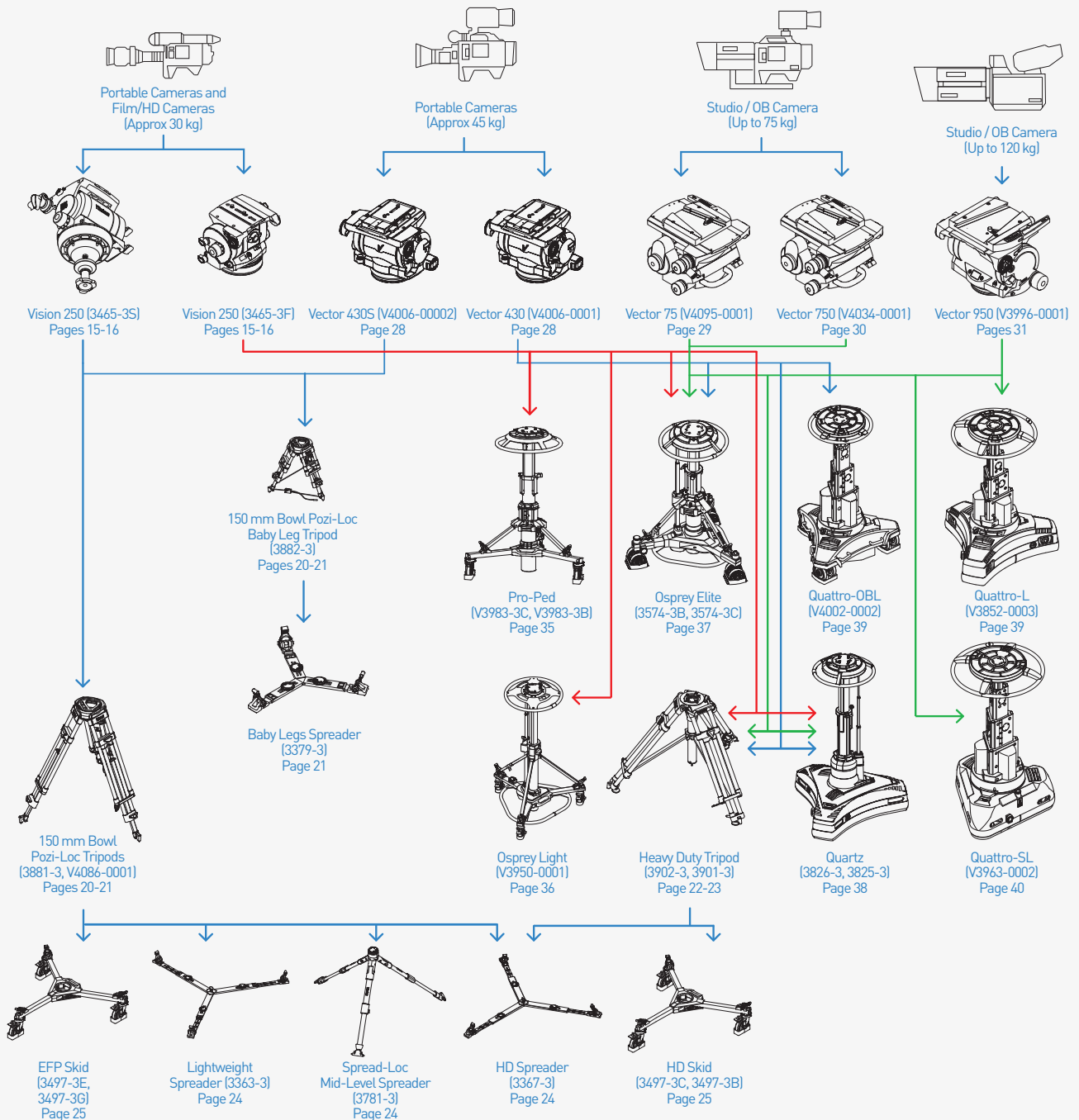

Contact us

Sales Offices

China

The Vitec Group plc China
Rm 706, Tower B,
Derun Building,
A No.3 YongAn Dongli,
Jianwai Ave., Chaoyang District,
Beijing, P.R. China 100022

T: +86 10 8528 8748
F: +86 10 8528 8749
e: sales.cn@vinten.com

France

Vitec Videocom S.A.R.L.
171, Avenue des Grésillons
92635 GENNEVILLIERS Cedex
France

T: +33 820 821 336
F: +33 825 826 181
e: sales.fr@vinten.com

Germany

Vitec Videocom GmBH
Erfurter Straße 16
85386 Eching
Germany

T: +49 89 / 321 58 200
F: +49 89 / 321 58 227
e: sales.de@vinten.com

UK

Vitec Videocom Ltd
William Vinten Building
Western Way
Bury St Edmunds
Suffolk IP33 3TB
UK

T: +44 1284 752 121
F: +44 1284 750 560
Sales Fax: +44 1284 757 929
e: sales.uk@vinten.com

Japan

Vinten Japan KK
Shibakoen 3-cyome Bldg, 1F
3-1-38 Shibakoen, Minato-ku,
Tokyo 105-0011
Japan

T: +81 3 5733 6410
F: +81 3 5733 6425
e: sales.jp@vinten.com

Singapore

Vitec Videocom Pte Ltd
6 New Industrial Road
#02-02 Hoe Huat Industrial
Building
Singapore 536199

T: +65 6297 5776
F: +65 6297 5778
e: sales.sg@vinten.com

USA

Vitec Videocom Inc
16 Progress Drive
Shelton CT 06484
USA

T +1 203-929-1100
F +1 203-925-2684
Toll Free Sales: 1 888 2 Vinten
e: sales.us@vinten.com

USA

Vitec Videocom Inc
2701 N Ontario St
Burbank CA 91504
USA

T: +1 818 847 8666
F: +1 818 847 1205
e: sales.us@vinten.com

Brazil

Vitec Group Brazil
Vitec Brazil Tecnologias Ltda.
Rua Quintana, 950 - cj.32
Brooklin - São Paulo - Brazil
Cep 04569-011

T: +55 11 5102 4001
F: ++55 11 5103 1164

Credits

Vinten would like to acknowledge
and thank the following people for
their contributions to this brochure:

Alister Chapman,
DOP & Stereographer, UK
www.alisterchapman.com

Chris Soucy,
New Zealand
www.dvinfo.net/author/chris-soucy

Christian La Fontaine,
Director of Photography

Derran Rootring,
Netherlands, Independent Film Maker,
www.derrannl.blogspot.co.uk

Donald A. Morgan,
ASC
www.donaldmmorganasc.com/about.html

Elizabeth Pollock,
Blue Marble Productions, USA

Fountain and Talkback
Thames/Syco TV, UK

Jay Williams,
Anglia Ruskin University, UK

Laurie Gilbert,
Director of Photography

Martin Gremmelspacher,
ask TeleVision, Germany

NBC

Paul Maibaum ASC,
Director of Photography, USA

SIS LIVE / BBC Sport, UK

talkbackTHAMES, UK

Telegenic Ltd., UK

The London Studios, UK

Tom Guilmette,
Director of Photography, USA
www.tomguilmette.com

Tom Klein,
O-Line Video, Australia
www.olinevideo.com.au

Wige Media AG,
Germany



Dealer stamp:

Changes in Product Specification Vinten reserve the right to alter specifications or change materials where absolutely necessary. All sizes shown throughout this brochure are approximate and colours shown are as accurate as modern reproduction methods will allow. No liability can be accepted for any variation.

©2013 The Vitec Group plc

@Vinten, Vision, Vector, Quickfix & Quickfit are registered trademarks of The Vitec Group plc.

QUALITY SYSTEMS APPROVED TO ISO 9001:
2000 Certificate No: Q09508