

Canon

J17ex 7.7B

Highest Quality "Standard" lens achieving the widest angle, a compact size and now including enhanced digital features



@IFxS

J17ex7.7B

eIFxs

Highest Quality "Standard" lens achieving the widest angle, a compact size and now including enhanced digital features

The **eIFxs** technology consists of two meanings that start from the letter "e". One is the "Ecological Design", the design harmless to the environment. The other is the "enhanced digital" technology which improves the performance of the digital drive unit. Of course, the new series inherits all the advantages from its predecessor, the IFxs series, which includes the advanced optical design concept, based on the X element technology.

The Features of e-IFxs Enhanced Digital Drive

The **eIFxs** series is equipped with an informational display and a Digital Function Selector so that the user can customize the enhanced digital functions much more easily and precisely. This new design enables the user to bring out the digital functions fully. In addition, the drive unit can memorize 9 patterns of user-customized settings and also transmit the data between different drive units.

Ecological Design

It is Canon's policy to not pollute the earth and through research we are quickly reaching the goal.

The **eIFxs** series has avoided using any materials or substances that could pollute the environment.

The optical parts, featuring lead free glass, are designed to be completely non-polluting and the mechanical parts are virtually free of all harmful products to the earth.

It is our intention that as soon as possible our lenses will minimize environmental impact.

X-Element & Power Optical System

Canon has developed breakthrough optical design concepts using a newly developed optical element in the most effective way. We have named this design concept the "Power Optical System" which can achieve higher specifications and quality in a smaller size and lighter weight, using a unique optical "Element" which realizes complete elimination of its aberration. Thanks to X-Element & Power Optical System, the J17ex7.7B is the same size and weight as its predecessor offering both more telephoto and a wider angle. The 59.5 x 46.4 angular field of view at 7.7mm sets new standards and is the widest angle of any lens in its class.

eIFxs Digital Drive System

Canon's enhanced Digital Drive System with informational display provides outstanding operation and features.

Shuttle Shot :

By memorizing any two focal lengths, the Digital Drive can automatically "shuttle" between the two points, moving in either direction.

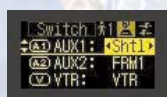

Framing Preset :

An angle of view can be preset in either of two memories and the lens will zoom to that position by pushing a simple button. During a performance, framing preset will reproduce the zoom position decided upon at the rehearsal. It's easy to repeat the same zoom as often as you like at the highest speed or in a preset zoom speed.



Speed Preset :

A specific zoom speed can be preset in memory and it is possible to repeat the zoom speed as often as you like by pushing a simple button.



- "Zoom Track" allows the camera operator to adjust the electronic focal length to their desired range by memorizing zoom positions at both the tele and the wide side of the zoom.
- User settings for zoom and focus curve mode for precise control based upon the users requirement.
- PC connection for remote control or diagnosis can be accomplished via a communication interface on the lens and personal computer with optional software.
- Canon offers a unique digital Zoom Demand, the ZSD-300D and digital Focus Demand, the FPD-400D. The ZSD-300D zoom demand will operate the shuttle shot and frame preset features of the lens. All digital demands connect to the lens via a new one-touch 20-pin connector. All current analog demands are compatible with digital drive lenses.
- By using an adapter cable, it is possible to use the Studio/Field digital lens controllers with the J17ex7.7B.
- CROSSOVER(Dual Aspect ratio Switching System)
The J17ex7.7B is available with the crossover option in two versions, the J17ex7.7B WRSD/WASD with 2X extender and the J17ex7.7B VRSD/VASD without 2X extender for switchable cameras.
- **Accessories**
Optical Accessories:82mm Filters

Momentary Iris Switch

Zoom operation switch



Return switch

[Aux2] switch for enhanced operation

Digital Function Selector

Display switch



Informational Display

VTR switch

[Aux1] switch for enhanced operation

Memory switch



Ecological Design

Vari-Polar Hood

SHORT M.O.D., 0.6m(1ft 9in)

COUNTERMEASURES AGAINST GHOSTING AND FLARES

ZOOM RATIO 17X

- Faster and quieter servo system
maximum zoom speed : 0.7 sec.

WIDEST ANGLE AVAILABLE

59.5° AT 7.7mm

CROSSOVER MODE 

- For 16:9/4:3 switchable cameras.(Option)

Built-in 2X Extender

SPECIFICATIONS

J17ex 7.7B	NORMAL4:3		16:9		SWITCHABLE 4:3		
Image Format	8.8 x 6.6mm ; φ 11.0mm		9.6 x 5.4mm ; φ 11.0mm		7.2 x 5.4mm ; φ 9.0mm		
Built-in Extender	1.0X	2.0X	1.0X	2.0X	1.0X	1.2X	2.4X
Zoom Ratio			17X				
Range of Focal length	7.7-131mm	15.4-262mm	7.7-131mm	15.4-262mm	6.4-109mm	7.7-131mm	15.4-262mm
Maximum Relative Aperture	1:1.8 at 7.7~102.5mm 1:2.3 at 131mm	1:3.6 at 15.4~205.0mm 1:4.6 at 262mm	1:1.8 at 7.7~102.5mm 1:2.3 at 131mm	1:3.6 at 15.4~205.0mm 1:4.6 at 262mm	1:1.8 at 6.4~103.3mm 1:1.9 at 109mm	1:1.8 at 7.7~102.5mm 1:2.3 at 131mm	1:3.6 at 15.4~205.0mm 1:4.6 at 262mm
Angular Field of View	59.5°x46.4° at 7.7mm 3.85°x2.89° at 131mm	31.9°x24.2° at 15.4mm 1.92°x1.44° at 262mm	63.9°x38.6° at 7.7mm 4.20°x2.36° at 131mm	34.6°x19.9° at 15.4mm 2.10°x1.18° at 262mm	59.5°x46.4° at 6.4mm 3.85°x2.89° at 109mm	50.1°x38.6° at 7.7mm 3.15°x2.36° at 131mm	26.3°x19.9° at 15.4mm 1.57°x1.18° at 262mm
Minimum Object Distance(M.O.D.)	0.6m(10mm with Macro)						
Object Dimensions at M.O.D.	63.1x47.3cm at 7.7mm 3.8x2.9cm at 131mm	31.6x23.7cm at 15.4mm 1.9x1.5cm at 262mm	68.5x38.5cm at 7.7mm 4.2x2.4cm at 131mm	34.3x19.3cm at 15.4mm 2.1x1.2cm at 262mm	63.1x47.3cm at 6.4mm 3.8x2.9cm at 109mm	51.8x38.5cm at 7.7mm 3.1x2.4cm at 131mm	25.9x19.3cm at 15.4mm 1.6x1.2cm at 262mm
Size(IRSD)	163.9(W)x106.3(H)x197.4(L)mm						
Approx.Mass (IRSD/IASD)	1.47kg(3.24lbs)/1.57kg(3.46lbs)						
	IRSD/IASD				VRSD/VASD		—
					WRSD/WASD		

DIMENSIONS

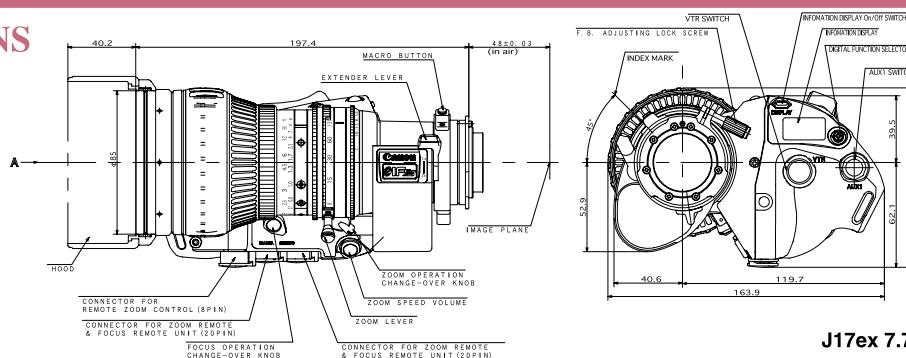

J17ex 7.7B IRSD (Unit:mm)

CONTROL ACCESSORIES

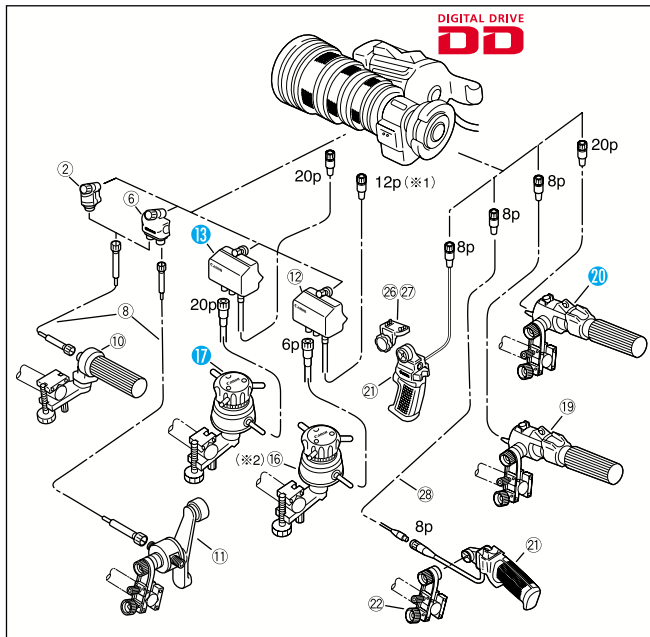

(※1) 33 CC-2012 conversion cable is necessary to connect between IRSD Digital Drive Lens and FPM-420.

(※2) 32 CC-2006 conversion cable is necessary to connect between IASD Digital Drive Lens and FPD-400.

#	Unit	Description	CODE
2	FFM-100	Flex Focus Module	1824A015
6	FFM-200	Flex Dual Module	1824A013
8	FC-40	Flex Cable	1824A010
10	FFC-200	Flex Focus Controller	1824A014
11	FZC-100	Flex Zoom Controller	1824A021
12	FPM-420	Focus Positional Servo Module	1824A026
13	FPM-420D	Focus Positional Servo Module	1824A129
14	FPM-500	Focus Positional Servo Module	1824A027
16	FPD-400	Focus Positional Demand	1824A018
17	FPD-400D	Focus Positional Demand	1824A124
19	ZSD-300A*/M	Zoom Demand (A or M types, depends on applicable camera)	A 1824A066 M 1824A067
20	ZSD-300D	Zoom Demand	1824A123
21	ZSG-200A*/M	Zoom Servo Grip (A or M types, depends on applicable camera)	A 1824A068 M 1824A069
22	CR-10	Clamper	1824A007
26	ZGA-400**	Grip Adapter	0025T616
28	EC-80	Zoom Extension Cable (8P)	1824A009
32	CC-2006	Conv. Cable (20pM-6pF)	1824A125
33	CC-2012	Conv. Cable (20pM-12pF)	1824A126

OPTICAL ACCESSORIES

Close-Up Lenses:
82CL-UP800H
82CL-UP1300H

Teleside Converter 1.5X:
T15-II

Wide Converter:
W80-IIIB

Wide Attachment 0.75X:
WA-75II

Fish-Eye Attachment:
FEA-IIIB

Hood Cap:
Rubber Hood:

Filters(82mm):
Sky / UV / ND8 / Sft /
Crs / Snw / Sny / PL

Adapter
85-II

J17ex 7.7B

Dust Cap

Standard Composition:

- Lens
- Hood Unit(Hood Cap,Rubber Hood.)
- Dust Cap.
- Operational Manual.

MODEL	CODE
82CL-UP800H	1823A041
82CL-UP1300H	1823A042
T15-II	1823A005
W80-IIIB	1823A006
WA-75II	1823A008
FEA-IIIB	1823A011
Adaptor85II	1824A002
UV / 82P0.75	1823A030
Sky / 82P0.75	1823A031
Crs / 82P0.75	1823A032
SNW / 82mmP0.75	1823A034
SNY / 82mmP0.75	1823A033
PL / 82mmP0.75	1823A038
SFT / 82mmP0.75	1823A037
ND4 / 82mmP0.75	1823A035
ND8 / 82mmP0.75	1823A036

North & South America

Canon U.S.A., Inc.
Broadcast and Communications Div. (Headquarters)
400 Sylvan Avenue Englewood Cliffs, NJ 07632
Tel:(201)816-2900/(800)321-4388 Fax:(201)816-2909
Email:bctv@usa.canon.com
http://www.canonbroadcast.com/

Chicago

100 Park Blvd. Itasca, IL 60143
Tel:(630)250-6231 Fax:(630)250-0399

Atlanta

5625 Oakbrook Pkwy. Norcross, GA 30093
Tel:(770)849-7895 Fax:(770)849-7888

Los Angeles

15955 Alton Parkway Irvine, CA 92618
Tel:(949)753-4330 Fax:(949)753-4337

Dallas

3200 Regent Blvd. Irving, TX 75063
Tel:(972)409-8871 Fax:(972)409-8869

Latin America

Tel:(954)349-6975 Fax:(201)816-2909

Canada

Canon Canada, Inc.
Optics Division 6390 Dixie Road
Mississauga, Ontario, L5T 1P7, Canada
Tel:(905)795-2012 Fax:(905)795-2140

Europe/Africa/Middle East

Canon Europa N.V.
Broadcast and Communications Div.
Bovenkerkerweg 59-61
1185 XB Amstelveen
Tel:+31(0)20-5458905 Fax:+31(0)20-5458203
Email:tvprod@canon-europe.com
http://www.canon-europe.com/tv-products

Australia

Canon Australia Pty. Ltd.
Optical Products Division
1 Thomas Holt Drive, North Ryde, NSW 2113
Tel:+61(0)2-9805-2000 Fax:+61(0)2-9805-2444

China

Canon (China) Co., Ltd.
Optical Products Division 15F South Tower, Beijing
Kerry Center, 1 Guang Hua Road,
Chao Yang District, 100020, Beijing, China
Tel:(010)8529-8488 ex 133 Fax:(010)8529-6606
http://www.canon.com.cn

Asia/Japan

Canon Inc.(Broadcast Equipment Group)
20-2, Kiyohara-Kogyo-Danchi, Utsunomiya-shi,
Tochigi-ken, 321-3292
Tel:+81(0)28-667-8669 Fax:+81(0)28-667-8672
http://www.canon.com/bctv

Canon

Specifications subject to change without notice