

Panasonic
ideas for life



Super Dynamic III
Network Colour Dome Camera

WV-NS202



Introducing a network camera with pictures so clear,
they exceed the human eye

SUPER DYNAMIC III
NETWORK COLOUR DOME CAMERA
WV-NS202

Exceptional quality, reliable performance, extreme versatility. Panasonic's i-Pro WV-NS202 Super Dynamic III network dome camera has arrived.

Panasonic, the leader in video surveillance, introduces a PTZ network camera ahead of its time. Featuring **Super Dynamic III** and progressive output, Panasonic has created unparalleled high-sensitivity and high quality image reproduction. The highly reliable WV-NS202 features image backup functions and industrial grade mechanisms while remaining cost effective. Designed for professional surveillance applications, the WV-NS202 **Super Dynamic III** network dome camera is worthy of the leading role.



Designed to produce High-quality Images

Dealing with a variety of objects Pixel Based 128x Dynamic Range



Super Dynamic III integrates two images consisting of brighter image for dark area and darker image for bright area, and performs gradation compensation of contrast on the pixel base, ensuring accurate reproduction of objects in any situation. It achieves up to 128x dynamic range by using images taken at 1/60-second and 1/8,000-second shutter speeds.



Conventional
Depending on object position, the image may be marred by black spots or halo effects.

Super Dynamic III
Pixel Based 128x Dynamic Range reproduces every object.

Capturing remote objects smoothly 22x Zoom Lens

A 22x optical zoom lens with a focal distance f of 3.79-83.4mm comes standard. Combined with the 10x electronic zoom, 220x magnification is achieved, allowing for high-power surveillance and the capture of objects at long range.



Easy installation and IP configuration

Power over Ethernet

With PoE (Power over Ethernet) IEEE802.3af, a separate power supply is not required. Both power and images are transmitted through the same cable. Just connect the cable to a PoE switch or PoE adaptor for simple installation.

One-touch Fitting Mechanism

Achieve a secure fit by aligning the recessed part of the main unit to the protruding part of the attached mounting bracket, and rotating the main unit clockwise.

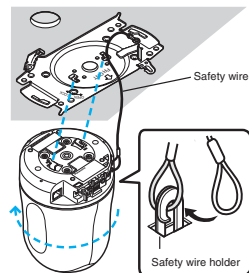

Various settings can be adjusted while monitoring the camera image

Equipped with pop-up setup menu, various settings can be adjusted while monitoring the actual camera image on the browser.

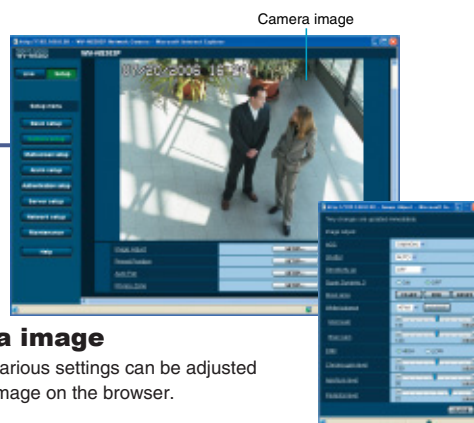

Setup panel

Versatile installations for various applications

Various optional brackets are available, ensuring versatile installation; direct ceiling mount, embedded mount and wall mount. The use of the supplied black cover conceals the direction of the lens.



Networking Function

Versatile operation MPEG-4/JPEG dual streaming



MPEG-4 and JPEG images can be output simultaneously. For example, MPEG-4 for live monitoring and JPEG for high quality recording. Full-rate transmission of up to 30 ips is possible in either MPEG-4 or JPEG mode. Whether using MPEG-4, JPEG or both, the WV-NS202 allows for versatile operation.

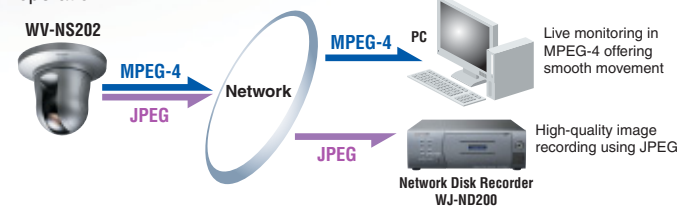

Main Menu



Images can be stored in the camera's on-board SD memory card slot with a single click.

- Image from 16 cameras can be displayed in 4 different Quad screen (JPEG only) or 16-screen (JPEG only). Compatible camera model includes WV-NP472, WV-NW470S Series, WV-NS320 Series, WV-NP1000 Series, WV-NP240 Series and WV-NF284 (Contact Panasonic for detail).
- Pan and tilt camera control on a quad-display is possible.
- Full screen mode is available simply by clicking the full screen button.
- Mouse controls allow for zoom, pan and tilt operations.

FRAME RATE CHART

Image Resolution	Mode	Image Settings									
		0 Super Fine	1 Fine	2	3	4	5 Normal	6	7	8	9 Low
VGA (640 x 480)	Image Size (KB)	128	96	80	64	56	48	40	32	28	24
	Frame Rate (ips)	10	14	17	21	24	30	30	30	30	30
	Bit Rate (Mbps)	10.2	10.8	10.9	10.8	10.8	11.5	9.6	7.7	6.7	5.8
QVGA (320 x 240)	Image Size (KB)	44	40	36	32	28	24	20	16	14	12
	Frame Rate (ips)	26	28	30	30	30	30	30	30	30	30
	Bit Rate (Mbps)	9.2	9.0	8.6	7.7	6.7	5.8	4.8	3.8	3.4	2.9

Highly resistant to network interference SD memory card slot

In the event of network interference, surveillance images are automatically backed up to an SD memory card in cooperation with a FTP server or Panasonic network disk recorder. Even during network interruption, surveillance images can be viewed later. Manual and Alarm recording on the SD memory card is also possible.



Voice exchange 2-way audio feature

Audio monitoring of the peripheral area is made possible by connecting a microphone directly to the camera. Furthermore, the provision of audio output enables voice public-addressing from a PC by connecting an amplifier-integrated loudspeaker. (Voice alternates between transmission and reception.) (ITU-T Standard G.726 Voice Function)

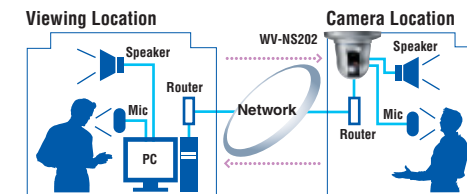

FTP server transfer:

JPEG images can be transferred to a pre-designated FTP server periodically or upon an alarm.

Alarm E-mail notification:

E-mails can be transmitted to up to four mail addresses with an alarm image.

SYSTEM EXAMPLE

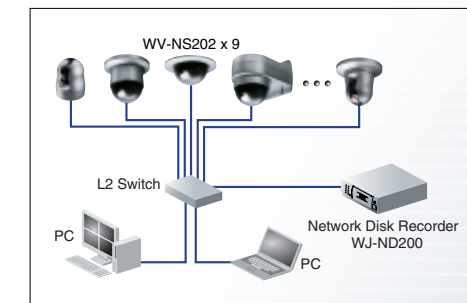

MPEG-4

Image Resolution	Mode	MPEG-4 Bit Rate Settings								
		4,096 kbps	3,072 kbps	2,048 kbps	1,536 kbps	1,024 kbps	512 kbps	256 kbps	128 kbps	64 kbps
VGA (640 x 480)	Low	30	30	30	25	22	10	5	2	1
	Normal	30	30	30	22	14	8	3	1	0.4
	Fine	27	22	19	13	9	4	1.5	0.5	0.2
QVGA (320 x 240)	Low	30	30	30	30	30	24	24	10	4
	Normal	30	30	30	29	28	24	12	4	1.5
	Fine	30	28	28	28	27	12	5	2	0.5

(above all figures are approximate, actual figures may differ depending on the network, PC performance and complexity of the object.)

Features and Reliability for surveillance applications

Industrial grade mechanism

Heavy duty materials are used for rotating sections. The unit is designed to operate over a long period of time as a result of Panasonic's expertise in manufacturing highly reliable, industrial grade surveillance cameras.



High-speed rotation of 300 degrees/sec.

The camera rotates 350 degrees horizontally at a rotation speed of 300 degrees/sec., max. (when moving between preset positions), enabling the quick capture of objects. Vertical rotation is also quick at up to 100 degrees/sec.

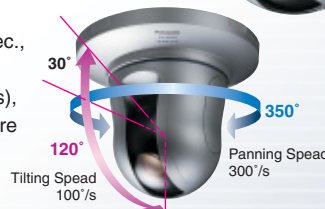

Video Motion Detection

Up to four detection areas can be set for each preset position and non-preset status. A total of 256 detection areas can be programmed with sensitivity High/Mid/Low.

Up to 64 preset positions

Up to 64 camera positions can be registered with user friendly GUI and image display. The positions can be selected through simple operations.

Auto Tracking

Panning and tilting are automatically executed so that a moving object can be centred on the screen.

Privacy Zone Masking

When private images exist within an image, masking those portions is possible. Up to eight masks can be applied with selectable gray mask and mosaic mask.

Versatile alarm functions

Five alarms sources such as Terminal 1-3, VMD and Panasonic alarm command are available with independent alarm action choose from camera positioning, Auto track, Alarm permission, VMD permission and Access permission (Permissions are for Terminal 1 only). Alarm terminal output can also be associated with alarm activation.

360 map-shot function

Still images of eight locations in a 360 degree arc are displayed as thumbnails. Clicking the thumbnail will direct the camera to the corresponding position and displays a live image of the location.

The above photographs were taken for the purpose of this explanation; actual performance and images may vary depending on environmental or other conditions.

SPECIFICATIONS [PAL]

Camera	Image Sensor	1/4-type interline transfer CCD		
	Effective Pixels	768 (H) x 494 (V)		
	Scan Mode	2:1 interface scan (with motion adaptive interface/progressive conversion)		
	Scanning Area	3.59 (H) x 2.70 (V) mm		
	Minimum Illumination	0.7 lux (sensitivity up: OFF, AGC: HIGH) 0.07 lux (sensitivity up: 10x, AGC: HIGH)		
	Dynamic Range	52 dB typical (Super Dynamic III: ON, Shutter speed: OFF)		
	AGC	ON (LOW) / ON (MID) / ON (HIGH) / OFF		
	Light Control	Automatic integration of ALC/ELC		
	Electronic Shutter	OFF (1/60), AUTO, 1/100		
	Super Dynamic III	ON/OFF (with BLC masking)		
	Sensitivity UP	OFF / AUTO (2x, 4x, 6x, 10x, 16x, 32x)		
	White Balance	ATW1 / ATW2 / AWC		
	Electronic Zoom	Up to 10x		
	Camera Title	Up to 20 characters (alphanumeric characters, marks)		
	Lens	Type	22x Zoom lens	
Focal Length		3.79 mm ~ 83.4 mm		
Angular Field of View		H: 2.6° (TELE) ~ 51.7° (WIDE) V: 2.0° (TELE) ~ 39.9° (WIDE)		
Maximum Aperture Ratio		1:1.6 (WIDE) ~ 3.0 (TELE)		
Min. Object Distance		1.6 m		
Aperture Range		F1.6 ~ 22, Close		
Pan and Tilt		Panning Range	0° ~ 350°	
		Panning Speed	MANUAL approx. 1°/s ~ 100°/s, preset: up to approx. 300°/s	
		Tilting Range	-30° ~ 90° (upward - level - downward) Selectable Tilting Angle: 0° / -5° / -10° / -15° / -20° / -25° / -30°	
		Tilting Speed	MANUAL approx. 1°/s ~ 100°/s, preset: up to approx. 100°/s	
		Number of Preset Positions	64	
		Auto Mode	OFF / preset sequence / auto pan / auto track	
		Map Shot	360° map shot / preset map shot	
		Network	Network IF	10Base-T / 100Base-TX, RJ45 connector
			Image Resolution	VGA (640 x 480) / QVGA (320 x 240)
	Image Compression		MPEG-4: Image quality: LOW/NORMAL/FINE Transmission type: UNICAST/MULTICAST JPEG: Image quality: 10 steps Transmission type: PULL/PUSH	
	Image Refresh Rate		0.1 ips ~ 30 ips (Frame rate of JPEG will be limited when transmitting JPEG and MPEG-4 simultaneously)	
	Audio Compression		G.726 (ADPCM) 32 kbps / 16 kbps	
	Bandwidth Control		64 kbps / 128 kbps / 256 kbps / 512 kbps / 1,024 kbps / 2,048 kbps / 4,096 kbps / Unlimited	
	Supported Protocol		TCP/IP, UDP/IP, HTTP, FTP, SMTP, DHCP, DNS, DDNS, NTP, SNMP, RTP	
	Supported OS		Microsoft Windows 2000 Professional SP4, Microsoft Windows XP Home SP2, Microsoft Windows XP Professional SP2	
Supported Browser	Internet Explorer 6.0 SP2 (Windows XP Home/Professional SP2) Internet Explorer 6.0 SP1 (Only Windows 2000 Professional SP4)			
FTP Client	Alarm image transfer, Periodic image transfer			
Multi Screen	Image from 16 cameras can be displayed in 4 different Quad screen (JPEG only) or 16-screen (JPEG only)			
SD Memory Card (Option)	Manual REC/Alarm REC/Backup upon network failure. Compatible SD card: Panasonic 64MB, 128MB, 256MB, 512MB, 1GB, 2GB model. SDHC standard card not supported.			
Alarm Email	Yes			
Time Date Display	Time: 12H/24H, Date: 5 formats on the browser			
Security Measures	User/Host authentication, User level: 3 levels			
Input/ Output	Monitor Output	1.0 V [p-p] / 75 Ω, PAL composite, ø3.5 mm mini jack		
	External I/O Terminals	ALARM IN 1, ALARM IN 2/ALARM OUT, ALARM IN 3/AUX OUT (x1 each)		
	Microphone	MIC IN (Applicable microphone; Plug-in power type) Supply voltage: 2.5 V ± 0.5 V Input impedance: 3 KΩ ± 10 %		
Alarm	Audio Output	AUDIO OUT ø3.5 mm stereo mini jack (monaural output) Line level		
	Alarm Source	Terminal input 1/2/3, VMD, Panasonic protocol		
	Alarm Action	Preset position call, Auto track, Alarm permission, VMD permission, Access permission, E-mail, Alarm FTP, Recording on SD memory, Terminal output, Panasonic protocol output		
General	Alarm Control	Reset		
	Power Source	12 V DC, PoE (IEEE802.3af compliant)		
	Power Consumption	12 V DC: approx. 1,000 mA, PoE: approx. 12.0 W (Class 0 device)		
	Ambient Operating Temperature	-10 °C ~ +50 °C		
	Ambient Operating Humidity	90 % or less (no condensation)		
	Dimensions	ø115 mm (D) x 154 mm (H) (excluding the 12 V DC power cord plug)		
Weight	Camera: approx. 850 g Accessories (Camera mounting bracket, decorative cover): approx. 200 g			

MAJOR OPERATING CONTROLS & TERMINALS

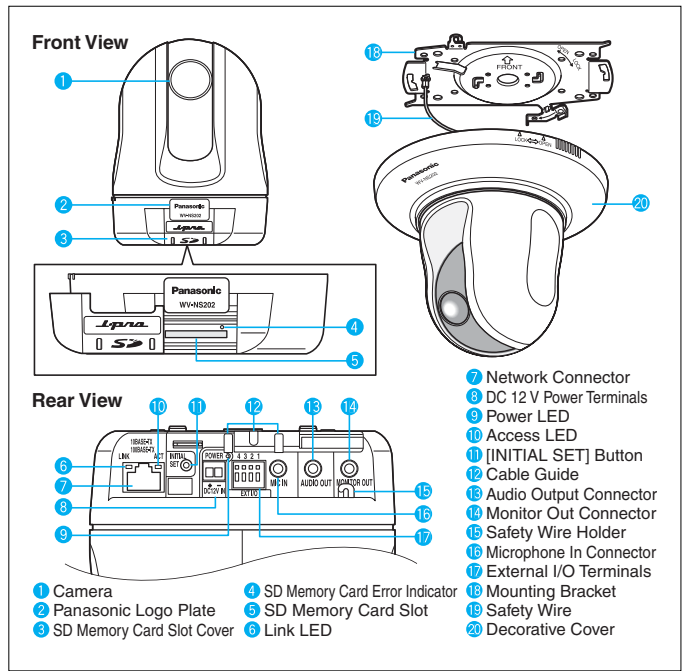

DIMENSIONS

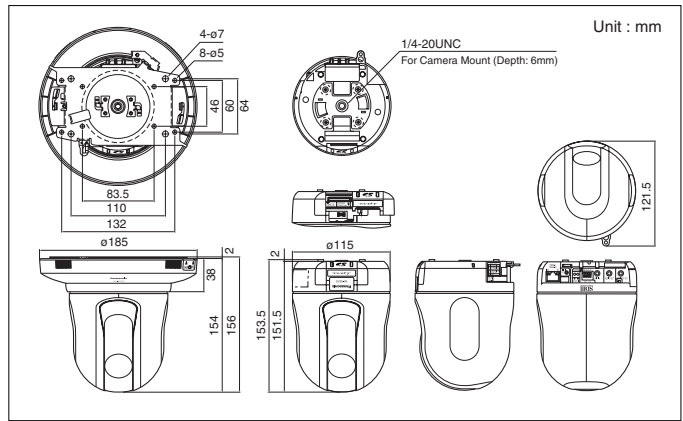

OPTIONAL COMPONENTS & ACCESSORIES



Trademarks and registered trademarks – Microsoft, and Windows are registered trademarks of Microsoft Corporation in the U.S. and other countries.
 – SD logo is a trademark.

Important – Safety Precaution: carefully read the operating instructions and installation manual before using this product.

– Panasonic can not be responsible for network performance and/or other manufacturer products that reside on the network.

• All TV pictures/menu are simulated. • Weights and dimensions are approximate. • Specifications are subject to change without notice. • These products may be subject to export control regulations.

DISTRIBUTED BY:

Panasonic System Solutions Company
Matsushita Electric Industrial Co.,Ltd.
 4-3-1, Tsunashima-higashi, Kohoku-ku, Yokohama,
 223-8639, Japan
 Tel 81(0)45-540-5769
 Fax 81(0)45-540-5773
 URL <http://panasonic.co.jp/psc/ctw/en/index.html>

Panasonic
 Panasonic is the brandname of Matsushita Electric.
 Printed in Japan
 WV-JKNS202C(2N-771)